

**STRATEGY
RESEARCH
PROJECT**

The views expressed in this paper are those of the author and do not necessarily reflect the views of the Department of Defense or any of its agencies. This document may not be released for open publication until it has been cleared by the appropriate military service or government agency.

JOINT COMMUNICATIONS INTEROPERABILITY

BY

LIEUTENANT COLONEL ROBERT J. FASULO
United States Army

DISTRIBUTION STATEMENT A:
Approved for public release.
Distribution is unlimited

USAWC CLASS OF 1996

19960610 022

DTIC QUALITY INSPECTED 8



U.S. ARMY WAR COLLEGE, CARLISLE BARRACKS, PA 17013-5050

USAWC STRATEGY RESEARCH PAPER

The views expressed in this paper are those of the author and do not necessarily reflect the views of the Department of Defense or any of its agencies. This document may not be released for open publication until it has been cleared by the appropriate military service or government agency.

JOINT COMMUNICATIONS INTEROPERABILITY

by

Lieutenant Colonel Robert J. Fasulo
United States Army

COL Ronald E. Ouellette
Project Advisor

DISTRIBUTION STATEMENT A: Approved for public release. Distribution is unlimited.

U. S. Army War College
Carlisle Barracks, Pennsylvania

ABSTRACT

AUTHOR: Robert J. Fasulo (COL), USA

TITLE: Joint Communications Interoperability

FORMAT: Strategy Research Paper

DATE: 29 March 1996 PAGES: 22 CLASSIFICATION: Unclassified

The forces that will fight the future battles of the United States will be constructed of multinational coalitions or joint services. The combatant commanders who assemble the forces must communicate in the most efficient manner, assembling the command and control mechanism with what the forces bring with them. This paper will investigate how the services ensure the communications systems that they develop or acquire are interoperable. It will analyze the instructions that have been provided by the Joint Chiefs of Staff and how two combatant commands have implemented those instructions.

Introduction

In the history of warfare command and control of forces has become a topic of discussion by many scholars and historians. Communication systems that support the command and control (C2) effort have been a key ingredient of this study and receive the same scrutiny that the more ethereal command and control attains because without proper communications, command and control would be negated or severely degraded. As warfare has evolved to become joint or multinational, so too, have the various command and control systems that our warriors use to fight. This presents a great challenge to those who must ensure that the varied systems of the future are interoperable. To simply ensure that all systems are interoperable electrically falls short of a total problem solution and those who have the task must look at proper planning, training, doctrine, procedures, hardware, software and operational techniques.

One only has to read the National Military Strategy to realize that the concept of joint warfare and multinational operations is the way the US military will fight. It would be difficult to find a document that espouses the thought of a single service conducting a large scale operation without the assistance of another service. A review of Desert Storm/Shield, Somalia, and Grenada reveals that command and control challenges abound for the communicator who has the mission to integrate the many diverse systems that each service brings to the effort. The geographical Commander in Chief (CINC) who is responsible for an operation looks to the J6 on the staff to solve the communication interoperability problems that a large diverse organization provides. This paper will identify some of the background issues that surfaced during those operations previously mentioned, what the joint staff has done to address those issues and how CINC's follow those issues to resolution.

Background

One of the first joint warfighting efforts undertaken by the United States was exercise Urgent Fury, the battle of Grenada. This effort has been analyzed throughout the services and is replete with communications interoperability problems that should have been addressed prior to any future effort. That was not the case, and some of the hard lessons that were learned in Grenada were relearned in subsequent conflicts. A quick synopsis of the conflict shows that the task force commander was a Navy admiral headquartered at sea with two land based task forces, one Army and one Marine, as well as a Special Forces task force under the command of an Army general. There is little doubt that this was a joint effort with the critical communication links being from the land based forces to the seaborne commander. This should have drawn the proper attention to ensure that this link was totally operational, the function of the J6. There are many lessons to be learned from this command and control arrangement, the least of which there was no **single** commander in charge of land forces. This fact could, and did, only exacerbate the communications interoperability problems. MG Trobaugh, Commanding General of the 82nd Airborne Division, was a very frustrated commander throughout the effort, not only at communications, but at the entire C2 structure. Although this structure is a topic for other study the fact that the lack of communications planning further compounded the problems will be addressed here.

From the outset of the effort the 82nd Airborne was slow to respond to commands from the overall task force commander, Admiral Metcalf, headquartered on the ship *Guam*. At one period MG Trobaugh landed on the island and tried to effect coordination with Admiral Metcalf, anchored less than ten miles away. Problems ensued due to radio, COMSEC, and frequency

incompatibility that did not allow the land based commander to talk to the overall command headquarters,¹ something that proper J6 planning and coordination, should have prevented. At another time in the battle Admiral Metcalf's staff wanted to make a boundary change between the US Marines and the US Army. This type of important information needed to get to both land based commanders in a timely fashion to prevent any possibility of fratricide. At the same time the Marines had landed close to some Army elements and MG Trobaugh wanted to contact the *Guam* to effect proper coordination. MG Trobaugh could see the ship anchored only a few miles away but could only talk intermittently via a satellite link.² This again shows the poor planning and coordination on the part of the joint communications staff, and quite possibly, the incompatibility of radios between the two commanders. The fact that Urgent Fury was an operation assembled with little coordination and much secrecy shows the necessity for published standards that the various services can *plan with and train to*. Not only should the technical standards be identified, but so too, should the operational standards. Technical standards and subsequent interoperability testing to ensure compliance would alleviate the equipment incompatibilities seen here. Training to published procedures would alleviate the frequency and COMSEC inconsistencies that plagued Urgent Fury. All of these areas are within the realm of the CINC and should be identified by the J6.

Desert Shield and Desert Storm provided many interoperability problems that presented challenges to the CINC in the successful accomplishment of his mission. The rapid buildup of forces did not allow for a detailed communications planning conference of any form to take place and much of the command and control architecture and the subsequent system that unfolded was pieced together. The fact that it worked as well as it did is attributable to the superb effort of all communicators in the theater of operations. The after action reports of the

various communication support elements indicate that the many interoperability issues were challenges to the various J6 or G6 elements. Not only did the Army have to address unique interoperability requirements with the other services but it also had to address the challenges that came with integrating several generations of equipment within its own elements.³

Within the theater, as a whole, the US Army brought several generations of analog equipment, as well as, the newer recently fielded digital communications system mobile subscriber equipment (MSE).⁴ The figure to the right shows the

different generations and types of equipment that were in VII Corps alone at the beginning of the ground effort. The senior signal leader in theater

stated that there were no joint interoperability problems due to the successful fielding of the joint service program known as TRI-TAC⁵ so the problems that arose for those designing and installing the systems throughout the theater became more operational and training issues. The

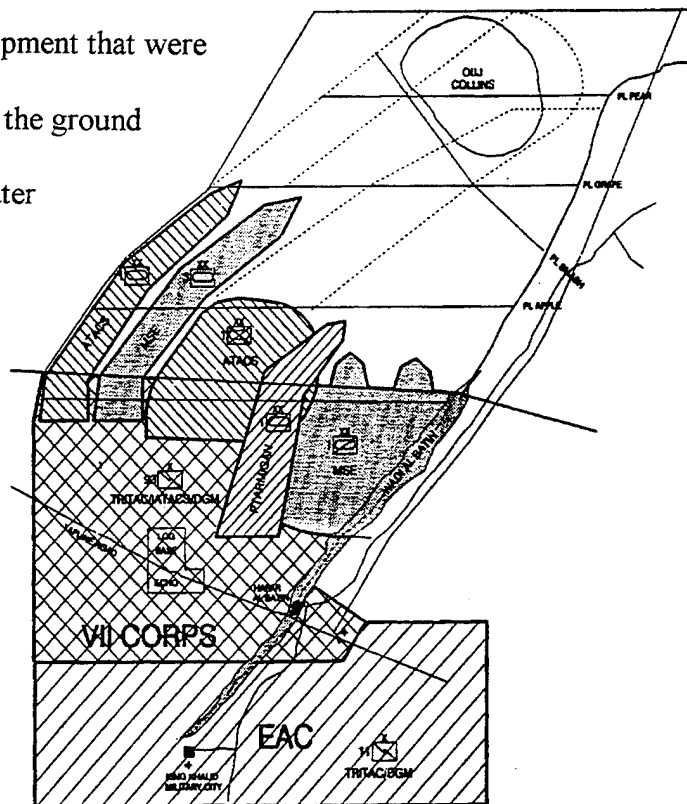

CENTCOM J6 had to focus effort on how to manage the network and direct assets, vice making them technically interoperable. This was a “come as you are” war and the command and control systems that came were interoperable because the material developers and designers had made them that way and tested them adequately. Operations of the future may not be that way, so the various combatant commanders must ensure that the units that become part of their organizations

know the interface standards, the interoperability requirements, and how to manage a joint network of unique service systems.

Operation Restore Hope in Somalia is an excellent example of the myriad of interoperability problems that can arise in joint and multinational operations. The range of challenges that confronted the communicators in theater stretched from software to hardware to procedural incompatibilities. On the software side UNITAF, a Marine centered headquarters, used the word processing package called Enable OA, which is an antiquated program, while the CENTCOM staff, as well as most other US military, used WordPerfect. This type of software incompatibility also entered the electronic mail arena⁶ which amplifies why the CINC must establish interoperability standards early.

An example of hardware incompatibility rests in the type of radios used by the Army and Marines. The radios were the same model, but the different level of upgrades caused the systems not to "talk" to each other as they were designed and the users were required to operate in a degraded mode.⁷ This problem was manifested by the fact that the same radio was used by the Navy in two different areas which caused problems in the dissemination of the daily air tasking order. The net effect of this poor interoperability effort was that for the first three weeks, while the Navy was offshore, the Army hospital at Mogadishu could not talk to the ships, nor could Army MEDEVAC helicopters get cleared to land on those same ships. This is another example of why a CINC, and the responsible J6, must ensure interoperability.

Interoperability concerns not only the software and hardware side, but also the operational aspects of joint and multinational efforts. In the Somalia operation the fact that there were several nations involved provided a significant challenge to the J6. Nations brought their own communications for internal sector, or headquarters, communications but when the links

crossed boundaries then the planners were presented with other concerns. You need only to envisage a scenario where a Bangladesh company is required to traverse a US Army sector to reinforce a US Marine unit. This was addressed in Somalia by the fact that a US signal unit lay down a backbone communication system that covered the entire area of operations thus providing the common thread throughout the country. This signal unit then received redeployment instructions and was replaced by a smaller, less capable, US signal unit, a divisional signal battalion. This battalion could not cover the amount of terrain that its predecessor had. The system now became a kluge of diverse multinational packages that did not link effectively.⁸ Once again the J6 was presented with an interoperability problem that, if not effectively handled, could cost lives or a less than successful mission completion.

The three previous joint efforts have shown the need for either joint interoperability doctrine or procedures that the various services can follow to ensure the CINC is supported by an interoperable system. Our combatant commands have a significant challenge in the newer world of diminishing resources because what they bring to the theater of operations must be efficient and work with everyone. The challenge rests not only within the US services but with our multinational partners as well. The US can not require every nation to subscribe to our standards of communications but we can provide the potential partners with the interface guidelines, or parameters, that will make the inevitable interconnection easier and feasible. The electrical, or technological, standards may be the easiest to identify to joint partners because there are engineers in every nation who speak the same technical terms and know how to "converse" on technical levels. The challenge for our CINC's is to identify and solve the interoperability problems that arise on the operational level and how we employ our communication systems. All members of the task force, or combatant command, must know

who is responsible to do what, when, and how far that responsibility extends. The J6's of the world have a significant challenge, and the question remains, are the tools available to assist them in successful mission accomplishment?

What's Available?

Joint doctrine for Command, Control, Communications, and Computer (C4) Systems Support to Joint Operations is provided in Joint Pub 6-0 dated 30 May 1995 and assigns various responsibilities to the CINC's. It is apparent that the four specified responsibilities are a result of the problems similar to those identified in the preceding pages and that as the staff process for joint operations is beginning to mature the specific responsibilities are being documented. This is something that was not in place during Urgent Fury, Desert Shield/Storm or Restore Hope. More specifically the combatant commanders C4 systems responsibilities are as follows:⁹

-
- Provide guidance to subordinate commands to ensure interoperability of the command wide C4 systems necessary to accomplish assigned operational functions.*
 - Forward the commands submission for C4 systems requirements to the Joint Staff for validation*
 - Designate a joint communications site manager (usually the joint force commander) when two or more component commands are collocated within a geographic area*
 - Provide C4 systems reporting for those systems under their combatant command (command authority) or operational control*
-

JCS Pub 6-0 definitively provides the baseline for developing guidance and assigning responsibilities. But the questions remain, does it go far enough and is it specific enough for the CINC to establish programs and ensure interoperability? Have the Joint Chiefs of Staff published instructions that the services are able to comply with? How do two geographic

CINC's, European Command (EUCOM) and Southern Command (SOUTHCOM) do this today? Those are questions that will be investigated and analyzed further.

JCS Pub 6-0 states the Chairman Joint Chiefs of Staff (CJCS) responsibility as “..the Chairman coordinates all communications in matters of joint interest addressed to the combatant commander by other authority.”¹⁰ This is not a truly restrictive directive and assumes that the CJCS is responsible for the publishing of guidance on joint communications. Carrying that further within the JCS pub we see that the combatant commander has other responsibilities not delineated in those shown previously. More specifically, “..report to the Chairman of the Joint Chiefs of Staff incompatibilities or lack of interoperability among C4 systems and between tactical systems and the DISN (Defense Information Systems Network).”¹¹ The pub states further that the CINC is responsible to “..Collect, provide comments on, and forward to the Chairman of the Joint Chiefs of Staff requirements applicable to joint operations for all C4 equipment that are generated by subordinate operational commands.”¹² This is where the real challenge comes to the combatant commander's J6.

To assist the combatant commanders CJCS Instruction 6212.01A was published and pertains to “Compatibility, Interoperability, and Integration of Command, Control, Communications, Computers, and Intelligence (C4I) Systems.” More simply stated its scope is to “..cover the compatibility, interoperability, and integration of new or modifications to existing DOD systems that have C4I capabilities.”¹³ The instruction goes in to some detail about the importance of interoperability but identifies some newer administrative requirements that go a long ways to ensure compatibility. It states systems that are developed for use in joint operations must be certified as interoperable with systems, with which they will have a requirement to exchange information.¹⁴ To further ensure that developing systems are not somehow forgotten

with time, and the ability to waive requirements, the instruction provides that a waiver from interoperability certification may be obtained but that it is not permanent. It does not, however, state how long the temporary waiver can be granted for. This appears to be a small hole in the system that can be addressed easily.

The system, as it is designed in the JCS Instruction, has a simple flow for requirements identification, interoperability testing and subsequent certification. The lines of demarcation are clear for both the paper audit trail and the hardware compliance so is there a problem that the combatant commanders can not overcome? First it is important to understand how the instructions direct the combatant commanders to work the interoperability issue. The ultimate goal of the communications infrastructure is to be totally interoperable and to be as cost efficient as possible with the final step the system certification. Requirements must first be identified by the user, most often the combatant commander, and validated by a technical authority. Who provides that technical validation becomes very clear as the process begins to unfold. The bottom line is that all C4I requirements certification must be provided to the Defense Information Systems Agency (DISA) for interoperability assessment.¹⁵ This makes the entire process more efficient because all requirements validation must go to one single DoD office where it will be checked for technical compliance to any standards that may apply, as well as, validate whether or not there is a similar system in another service that could save the user some research costs, or possibly, prevent a system failure.

In overall administration of the program the Joint Staff (J6I) will be the focal point for all Mission Needs Statements (MNS), Operational Requirements Documents (ORD), and in general any document in the C4I certification process. The process is comprised of two stages that are relatively simple, of which the first stage is requirements coordination and validation. As

previously mentioned this is the stage where the MNS and ORD's are coordinated through DISA to review need or duplication between services. The second stage presents the greatest challenge to the user because this is where the assessment and certification is completed. Actual testing of the system must occur which becomes another challenge for the C4I community.

The process ensures that the systems presented for acquisition are certified for interoperability if all steps are complied with. It is also designed to differentiate between Acquisition Category (ACAT) items, such as ACAT-I that are required to flow through the Joint Requirements Oversight Council (JROC), and still meet time standards. As the J6I receives the requirement documents, such as MNS or ORD, not only does the package go to DISA for review but it also goes to each service component for impact on their organization, warfighting systems, joint and combined interoperability and compatibility, integration, and adherence to standards.¹⁶ Comments gathered during this review are forwarded to DISA for the second stage, which is the certification and testing stage. Throughout this process DISA has been involved and they now become the integral player in the verification that a system proposed for acquisition is interoperable. Their arm to perform the certification testing is the Joint Interoperability Test Command (JITC) at Ft. Huachuca, Arizona. As a cost saving measure, previous testing performed at a service's test facility and the interoperability data or interface parameters used may be forwarded to the JITC engineers for technical evaluation. The system, as designed, is efficient if all services forward the appropriate test data to ensure a valid appraisal has been performed. This is amplified by the JCSI which states, "...All must work together to minimize test redundancy."¹⁷ The thing that concerns me most with this system is the timeliness and responsiveness to the CINC. ***Will the system work fast enough to get necessary equipment in the hands of the users, the overall Joint Task Forces?***

An analysis of the milestones in the JCSI implies that the system can respond to the CINC if, in fact, the necessary information is provided and the required staffing meets the published time standard. There is, of course, the immediate turn around items that by necessity cause ripples in the system, but the procedure is in place to get the certification completed and the equipment in the hands of the combatant commanders. ACAT I items, those that must pass through the JROC, flow through the process, from MNS/ORD submission to JROC approval/disapproval, in less than 120 days.¹⁸ Once this occurs the proposed acquisition item must begin its interoperability certification, then workload, priority, or quality of previous interoperability testing become the deciding factors. For those non ACAT-I items the process can be significantly streamlined and the time greatly reduced to get to the testing stage and then the same factors that influenced the ACAT-I items have an impact.

The process, as described above, is well defined and appears to be able to support a CINC's interoperability concerns. Following this down the chain one more link, what is a CINC responsible for other than what is described in JCS Pub 6-0? The JCS pub delineates those four primary responsibilities in a broad manner and have been discussed previously. The previous analysis shows how the process works once the combatant commander has forwarded the C4 requirements for Joint Staff validation. The question remains, how do they provide the guidance to the subordinate commands to ensure interoperability with command wide C4I systems? Documentation of some sort must be provided to the subordinate commanders identifying the parameters they must follow to ensure compliance. A look at two geographic CINC's, SOUTHCOM and EUCOM, shows that the information provided to their subordinate commands is somewhat broad, yet specific enough to ensure proper interoperability.

SOUTHCOM's road to interoperability presents a different challenge than other

combatant commands encounter for two reasons. The first is that the command is moving from the Panama Canal Zone to Miami in the very near future and secondly because the command is predominantly allied or civilian, with few US Armed Forces. The varied structure brings several new challenges to the combatant command since each civilian agency or national force bring their own C4I systems, or “stovepipes”, that must somehow be integrated in to an overall functioning command and control architecture. The Transition Road Map states “.The overriding problem with standalone, or “stovepipe,” systems...ranges from a lack of system interoperability with other functional systems to the potential of never becoming compatible or interoperable with future systems.”¹⁹ The SOUTHCOM J6 has recognized the interoperability challenges and addressed them in the roadmap to the future in a phased approach. The ultimate goal of the transition to the objective system is to ensure interoperability throughout with no gap in support to the many users of the SOUTHCOM network. The overriding direction that the J6 takes is to ensure the increased compatibility of data systems and subsequent electronic transfer. The current system is cumbersome at best and the fact that the command is moving now weighs in favor of SOUTHCOM because they can fix their problem with proper system integration by addressing interoperability. The various phases are timed as follows:

Near term: FY 95-96

Mid term: FY 97-98

Objective term: FY 99 and beyond

The near term includes the migration of functional applications and the installation of translation and security devices to interface with the Global Command and Control System (GCCS), which begins the interoperability process. The mid term phase is to field an integrated C4I system capable of generating a fused information product over an automated network for the commander. The objective system provides the interoperable link with the tactical commander

and the CINC.²⁰ How the J6, or the CINC, ensures that the integrated systems are interoperable then becomes the question. Does the SOUTHCOM Transition Road Map follow the direction of the JCSI to ensure interoperability?

The politically correct answer to the question above is yes, but I don't feel as though that is the correct answer. The SOUTHCOM plan is replete with the use of commercial off the shelf (COTS) equipment and the use of existing systems integrated in to the growing global network. The assumption is that the published standards are sufficient to ensure system interoperability, and that since the systems are already in use somewhere within DOD then the assumption is that testing may not be necessary. In no time line does the testing of integrated systems appear and this may ultimately cause the CINC problems that only a great deal of dollars and time can solve.

Responsibilities assigned various agencies comply with other JCS published documents so there does not appear to be a disconnect with who is supposed to do what. An example of this is that SOUTHCOM states a responsibility of DISA is "...Provides C4I architectural and systems engineering support in accordance with the Defense Information Infrastructure (DII) Architecture."²¹ The JCSI identifies that requirement on page C-5 but beyond the architecture, engineering and design phases the SOUTHCOM transition plan does not address testing and ensuring interoperability which reaffirms the fact that testing is not being planned. The overall conclusion that is reached after analyzing the SOUTHCOM Transition Plan is that, although interoperability is addressed, testing to ensure it all works is not being conducted or planned. The assumption that the system is being built by integrating existing programs and previously fielded communication networks will all work together may be a faulty assumption that would warrant further investigation on the part of the SOUTHCOM planners.

The actions of the Joint Staff and the CINC have been addressed previously so it is

beneficial to look at what another CINC provides to his subordinate commands. The operational or tactical arm of the combatant commander is the Joint Task Force and one command that has provided a great deal of valuable information on task force formation is EUCOM. This is the result of the simple fact that they have had the experience of standing up task forces and are more familiar in their subsequent interoperability concerns. The guiding document within EUCOM is ED 55-11²² which is replete with references to interoperability at the task force level. SOUTHCOM, in their transition road map dealt with the communications architecture on a macro level, but EUCOM's directive goes to a much lower level and gets in to more detail as to what are a staff officers or subordinate task force commanders interoperability requirements. Interoperability at the task force level can equate to something as simple as what type of software to use for word processing, data base management, graphics, spreadsheets or calendar management. ED 55-11 delineates the standards in several places and there is no ambiguity.²³ This may sound like an easy problem to solve but anyone who has served on a Joint Task Force comprised of US and allied nations has come to realize that this often causes many interoperability problems that are difficult to overcome and EUCOM has addressed this solidly with little chance for confusion.

The equipment interoperability side has also been addressed by EUCOM and, it too, eliminates much of the confusion that a task force commander can have. There are several documents that identify what type of radios a subordinate commander is required to bring and what nets they are supposed to enter. The various references go in to much detail and provide the communication planners at task force level with several checklists to follow to ensure interoperability concerns are addressed. What is critical to realize here is that if a joint task force is being formed by a CINC, it is too late to perform any type of interoperability testing, at a

DISA or JITC level, to ensure things work together so that whatever a component commander brings, then it must work with everyone else! This is when a J6 earns their pay and the more of things such as the EUCOM Brain Book²⁴ and the JTF Help List²⁵ that are available then the easier interoperability will become. In this area EUCOM has done a great deal to ensure that the information is available at every echelon to facilitate the formation of a task force and to make the interoperability of communications, command and control an easier task.

Conclusion

Interoperability of communication systems present a challenge that the combatant commanders must be prepared to address. The various joint publications have established a process that will enable the commanders to successfully integrate the myriad of systems that ultimately comprise the networks upon which their command and control will traverse. As the CINC identifies a requirement it enters the validation process within the Joint Staff as well as DISA where the actual testing to verify its interoperability begins. What is critical to this process is that the single focal point, DISA manages the testing results as well as conduct the tests. The standards upon which a system must be built are identified and tracked by the Joint Staff and compliance to that standard monitored by DISA. The timeliness of the process is designed so that it can be responsive to a CINC, provided there are not immediate needs, and appears to be functioning. I have shown that SOUTHCOM has complied with the intent of the JCSI but falls short in adequate testing of the objective system that will ultimately provide communications support for the command, which may be a dangerous position. The importance of interoperability testing can not be stressed enough and in SOUTHCOM's case the need is even more critical since they are integrating several networks of commercial off the shelf equipment as they relocate to the United States. To slight testing may ultimately cost a great

deal in time and in cost and all concerned must watch to ensure that this does not occur.

Although not previously mentioned, Atlantic Command uses the JCSI as their guideline for interoperability and have not augmented the process with cumbersome stages. EUCOM, at the task force level, has addressed the interoperability issues by, as a minimum, making the J6's aware of what to look for. Bottom line of this is that the combatant commanders are cognizant of the interoperability issues and challenges and are actively addressing their subsequent management. By doing so, they are wisely managing the precious resources they have while ensuring the communications systems that support them are efficiently built and designed, which is wise taxpayer stewardship. The successful integration of the systems that will make up our communications, command, control and computer networks is dependent on the adequate and complete testing for interoperability. What is in place now is sufficient to ensure that it will occur, but it must be complied with. There is room for deviation in time but not in standards, those in the technical area as well as in the procedural. All of the future system integrators and designers must adhere to the instructions that are published and not circumvent the letter nor the intent. It is particularly important to comply if our C4 systems are to be interoperable and satisfy the CINC's requirements. We can, and must, field equipment that is interoperable while doing so in a cost efficient and timely manner. The tools are there to do it, but we must follow the rules.

Endnotes

1. Major Mark Adkin, Urgent Fury: the Battle for Grenada, dtd 1984, pg. 221.
2. Ibid pg. 229.
3. 93rd Signal Brigade, VII Corps, After Action Report of Desert Shield and Desert Storm, dtd July 1991, tab b., page 8.
4. US Army Signal Center, "The US Army Signal Corps in Operation Desert Shield/Desert Storm, dated 1994, page 4.
5. Ibid.
6. Kenneth Allard, Somalia Operations: Lessons Learned, January 1995, page 80.
7. Ibid page 81.
8. Ibid page 79.
9. Joint Chiefs of Staff, Joint Pub 6-0: Doctrine for Command, Control, Communications, and Computer (C4) Systems Support to Joint Operations, Washington, DC, 30 May 1995, page III-5.
10. Ibid page IV-1, para 1. a.
11. Ibid page IV-1, para. 2.c.
12. Ibid page IV-1, para. 2.b.
13. Chairman of the Joint Chiefs of Staff, "Chairman of the Joint Chiefs of Staff Instruction 6212.01A", dated 30 June 1995, para 3, page 1.
14. Ibid, para. 4.b, page 2.
15. Ibid, para. 2, page B-2.
16. Ibid, para. 2.b, page B-2.
17. Ibid, para. 5, page B-7.
18. Ibid, page B-5.
19. USSOUTHCOM, "C4I Systems Transition Road Map", Quarry Heights, Panama, 27 July 1995, page 1-4.
20. Ibid, page 1-7.
21. Ibid, page 4-13.

22.US European Command, "ED 55-11 Joint Task Force Headquarters Organization and Standing Operating Procedures", Stuttgart, Germany, APO AE 09128-4209.

23.Ibid, page O-5.

24.USEUCOM, "Joint Task Force Staff Officers Brain Book", Stuttgart, Germany, April 1993, section M.

25.USEUCOM, "JTF Help List", Stuttgart, Germany, April 1993, section 6.

Bibliography

- Adkins, Major Mark. Urgent Fury: the Battle for Grenada. Lexington, Ma: Lexington Books, D.C. Heath Company. 1989.
- Allard, Kenneth. Somalia Operations: Lessons Learned. Ft. McNair, Washington, DC: National Defense University Press. 1995.
- Center for Army Lessons Learned, "Joint Tactical Communications: Operations Desert Shield-Desert Storm". Newsletter 92-1. US Army Combined Arms Command. Ft. Leavenworth, KS. 1992.
- Center for Army Lessons Learned, "Operations Other Than War Volume II, Disaster Assistance", Newsletter Number 93-6. US Army Combined Arms Command, Ft. Leavenworth, KS. Oct 1993.
- Joint Chiefs of Staff, Doctrine for Command, Control, Communications, and Computer (C4) Systems Support to Joint Operations, Joint Pub 6-0. Washin gton, DC. 30 May 1995.
- Joint Chiefs of Staff, "Joint Task Force Planning and Guidance Procedures". Joint Pub 5-00.2. Washington, D.C. Draft dated 1 October 1995.
- Joint Chiefs of Staff Instruction, "Compatibility, Interoperability, and Integration of Command, Control, Communications, Computers and Intelligence Systems", CJCSI 6212.01A. Washington, D.C. 30 June 1995.
- Office of the Command Historian, The US Army Signal Corps in Operation Desert Shield/Desert Storm, Office of the Command Historian, 1994.
- Speech by GEN Ronald Fogelman, Air Force Chief of Staff, "Information Operations: The Fifth Dimension of Warfare". Defense Issues Volume 10 number 47. Speech given to Armed Forces Communications Electronics Association, Washington, D.C. 25 April 95.
- Speech by Hon Emmett Paige Jr., Assistant Secretary of Defense C4I, "Retaining the Edge on Current and Future Battlefields". Defense Issues Volume 10 number 85. Speech given to Armed Forces Communications Electronics Association, Fayettevill, NC. 22 Aug 95.
- USEUCOM, "Joint Task Force Headquarters Organization and Standing Operating Procedures", ED 551-11, Stuttgart, Germany, APO AE 09128-4209
- USEUCOM, "JTF Help List". Stuttgart, Germany, APO AE 09128-4209. April 1993.
- USEUCOM, "Joint Task Force Staff Officers Brain Book." Stuttgart, Germany, APO AE 09128-4209. April 1993.

USSOUTHCOM, "C4I Systems Transition Road Map", Quarry Heights, Panama, APO AA 34003. 27 July 1995.

93rd Signal Brigade VII Corps, "After Action Report Operations Desert Shield and Desert Storm." Heilbronn FRG. 1991.