

TNO-report
95-CMC-R0615

**Torsional vibration analysis of a long propeller shaft
system driven by two diesel engines
(Diesel-direct system)**

TNO Building and
Construction Research

AMSTERDAM 1995

DISTRIBUTION STATEMENT K
Approved for public release
Distribution Unlimited

19960611 067



DISCLAIMER NOTICE

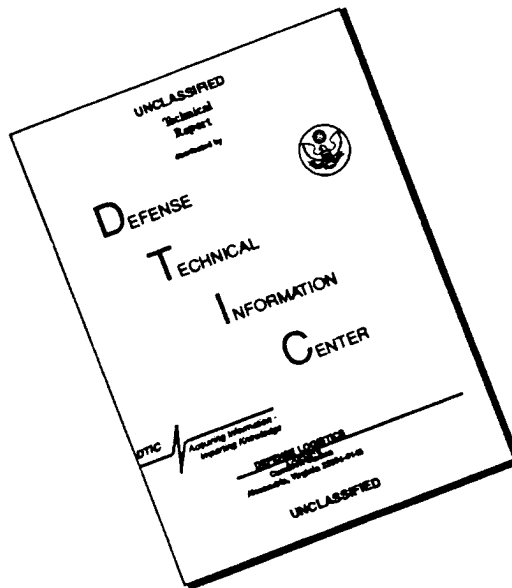

THIS DOCUMENT IS BEST QUALITY AVAILABLE. THE COPY FURNISHED TO DTIC CONTAINED A SIGNIFICANT NUMBER OF PAGES WHICH DO NOT REPRODUCE LEGIBLY.

TNO-report
95-CMC-R0615

**Torsional vibration analysis of a long propeller shaft
system driven by two diesel engines
(Diesel-direct system)**

TNO Building and
Construction Research

Lange Kleiweg 5, Rijswijk
P.O. Box 49
2600 AA Delft
The Netherlands

Phone +31 15 284 20 00
Fax +31 15 284 39 90
Telex 38270

Date December 31, 1995

Author(s) ir. H.S.T. Brockhoff
ir. P.P.M. Lemmen

DISTRIBUTION STATEMENT B

Approved for public release
Distribution Unlimited

Sponsor : Ministry of Defence
Royal Netherlands Navy
P.O. Box 20702
2500 ES 's-Gravenhage
The Netherlands

DTIC QUALITY INSPECTED

Classification
classified by : ir. I.P. Barendregt
Classification date : December 31, 1995

Title : ONGERUBRICEERD
Managementuittreksel : ONGERUBRICEERD
Report text : ONGERUBRICEERD
Appendices : ONGERUBRICEERD

All rights reserved.
No part of this publication may be
reproduced and/or published by print,
photoprint, microfilm or any other
means without the previous written
consent of TNO.

In case this report was drafted on
instructions, the rights and obligations
of contracting parties are subject to
either the Standard Conditions for
Research Instructions given to TNO
or the relevant agreement concluded
between the contracting parties.
Submitting the report for inspection to
parties who have a direct interest is
permitted.

The classification designation ONGERUBRICEERD is
equivalent to UNCLASSIFIED.

Contract number : A94/KM/125
Project number : 42775649
Approved : ir. G.J. Meijer
Visa : ir. G.T.M. Janssen

© TNO

Pages : 67 (incl. appendix, excl.
RDP and distribution list)



Managementuittreksel

Titel : Torsional vibration analysis of a long propeller shaft system driven by two diesel engines (Diesel-direct system)
Auteurs : ir. H.S.T. Brockhoff, ir. P.P.M. Lemmen
Datum : 31 december 1995
Opdrachtnr. : A94/KM/125
IWP-nr. : 792
Rapportnr. : 95-CMC-R0615

Bij het ontwerpen van nieuw te bouwen marineschepen wordt steeds vaker overwogen gebruik te maken van niet-conventionele voortstuwingssystemen. Systemen op basis van een elektrische voortstuwing staan momenteel sterk in de belangstelling. Ook het gebruik van niet-conventionele scheepsvormen kunnen speciale eisen stellen aan het voortstuwingssysteem. Een recent voorbeeld hiervan is het Amfibisch Transport Schip (ATS), waar een keuze werd gemaakt tussen een diesel-directe voortstuwing en een diesel-elektrische. Door de speciale vorm van het ATS zou in beide gevallen gebruik gemaakt moeten worden van een zeer lange schroefas: 74 m voor de diesel-directe voortstuwing en 43 m voor de diesel-elektrische voortstuwing.

Met als doel te onderzoeken of bij gebruik van dergelijke lange schroefassen de gevoeligheid voor torsietrillingen zodanig wordt dat ontoelaatbare torsietrillingsproblemen zullen optreden, zijn een tweetal case studies uitgevoerd naar het torsietrillingsgedrag van beide hiervoor genoemde voortstuwingssystemen. Dit rapport beschrijft de analyse van het diesel-directe systeem. De analyse van het elektrische voortstuwingssysteem is beschreven in TNO rapport 95-CMC-R0614.

Inmiddels is voor het ATS gekozen voor een diesel-elektrische voortstuwing. Deze keuze is niet bepaald door het torsietrillingsgedrag.

De hoofdconclusies van deze studie voor het diesel-directe voortstuwingssysteem zijn:

- (1) Bij motortoerentallen tussen 550 r/min en het maximum motortoerental zijn geen trillingsproblemen te verwachten. Het voortstuwingssysteem voldoet dan aan de eisen zoals gesteld in Lloyd's Register of Shipping.
- (2) Bij toerentallen lager dan 550 omw./min is er een gevaar voor *gear hammer* in de tandwielkast, omdat voor die toerentallen het torsiewisselkoppel (vibratory torque) groter is dan 70 % van het gemiddelde aandrijfkoppel (mean torque).
- (3) Bij toerentallen lager dan 320 omw./min wordt de elastische koppeling overbelast; mogelijk kan dit probleem worden opgevangen door de keuze van een andere elastische koppeling.
- (4) De in de punten (2) en (3) genoemde problemen worden niet veroorzaakt door de grote lengte van de schroefas.

Uit een vergelijking van het elektrische voortstuwingssysteem met het diesel-directe systeem blijkt dat de torsietrillingen in het elektrische voortstuwingssysteem significant lager zijn dan die in het diesel-directe systeem.

Contents

	Page
Managementuittreksel	2
Contents	3
1 Introduction	4
2 Model of the diesel-direct propulsion system	5
2.1 Overall model of one propulsion system	5
2.2 Model of the diesel engines and the torsional vibration damper	7
2.3 Model of the propeller	8
3 Natural frequencies, mode shapes and critical engine speeds	9
4 Forced vibration response by using the direct method	10
4.1 Stresses in the crankshaft	10
4.2 Stresses in the long propeller shaft	11
4.3 Results for the flexible coupling	12
4.4 Results for the gear transmission	12
5 Forced vibration response by using the magnifier method	13
5.1 Stresses in the crankshaft	13
5.2 Stresses in the long propeller shaft	14
5.3 Results for the flexible coupling	14
5.4 Results for the gear transmission	14
6 Discussion of results	15
6.1 Comparison of the direct method with the magnifier method	15
6.2 Effect of phase angle between the two engines	15
6.3 Torques in the flexible coupling	16
6.4 Torques in the gear transmission	16
7 Comparison of the electric system with the diesel-direct system	17
8 Conclusions	18
9 References	19
Tables	21
Figures	34
Appendix A: Critical engine speeds and vector summations	57

1 Introduction

In today's designs for naval vessels the use of unconventional propulsion systems is often considered. Propulsion systems based on electric motors and/or combinations with diesel engines or gas turbines may be very attractive from a technical point of view. Also the shape of the ship may be unconventional. A recent example in the Royal Netherlands Navy is the design of the Amphibious Transport Ship (ATS), where a choice will be made between a diesel-direct propulsion system and a diesel-electric system. Owing to the special shape of the ATS in both cases a unusual long propeller shaft will be used: 74 m for the diesel-direct system and 43 m for the diesel-electric system.

In order to investigate whether the use of such long propeller shafts may cause unacceptable sensibility to torsional vibrations, both previous mentioned systems have been analyzed. This report describes the analysis and results for the diesel-direct system. The analysis for the electric system has been described in [R.1].

The torsional vibration analyses have been performed by using the computer program TORPACK [R.2]. The results have been verified according to Lloyd's Register of Shipping [R.5].

Chapter 2 describes the model of the propulsion system.

Chapters 3 to 6 and the accompanying tables and figures show the results of the analyses.

In chapter 7 some results are compared with the results of the electric system.

Conclusions are drawn in chapter 8.

Note: in this report all vibratory frequencies will be presented in two units: cycles per second (Hz) and cycles per minute (c/min). The notation in c/min was added for easy comparison of the vibratory frequencies with the speed of the diesel engine, which will be presented in revolutions per minute (r/min) only.

2 Model of the diesel-direct propulsion system

In this chapter a description is given of the numerical model used in the torsional vibration analysis. Standard input values such as rotational inertias and stiffnesses are presented in section 2.1. Specific input for excitation torques and damping of the diesel engine are described in section 2.2 and further in chapters 4 and 5, because of the use of two different analysis methods. Input for the propeller is described in section 2.3.

Data has been used which was available at the start of the project, which was early 1994.

2.1 Overall model of one propulsion system

The Amphibious Transport Ship contains two uncoupled propulsion systems, one starboard and one port. For the diesel-direct option, these propulsion systems are equal, except for the direction of rotation of the propeller and a small difference in the gear transmissions as a consequence of equal directions of rotation of the diesel engines. Therefore it is sufficient to model only one propulsion system. Each propulsion system contains two diesel engines.

Figure 2.1 shows the model of the diesel-direct propulsion system. The dimensions in this drawing do not correspond with actual values as it is only a schematic representation of the model. Figure 2.2 shows the model for engine number 1 more in detail. In these figures masses are referred to as M_i and springs as K_i .

The model contains relevant rotational mass moments of inertia and stiffnesses from:

- both the diesel engines;
- the flexible couplings;
- the gear transmissions;
- the long propeller shaft;
- the propeller.

The long propeller shaft has been modelled with 19 masses (and 18 springs in between). This ensures a sufficient fine segmentation of the shaft to describe the vibratory behaviour accurately.

Table 2.I shows the rotational mass moments of inertia for each mass in the model and table 2.II shows the torsional stiffnesses of the springs.

The data in these tables has been gathered from the documents listed in chapter 9. In this report these documents are referred to by means of indices D.x between square brackets.

The rotational mass moments of inertia J_{M_i} of the masses on the long propeller shaft have been obtained from:

$$J_{M_i} = J_{shi} + J_{compi} \quad (1)$$

where J_{shi} is the contribution to the inertia of the shaft itself and J_{compi} the contribution of components such as liners.

The terms J_{shi} follow from:

$$J_{shi} = (\pi/32) \cdot \rho \cdot l_{M_i} \cdot d^4 \quad (2)$$

In this equation l_{M_i} is the length of the structural part represented by mass M_i , ρ is the density of steel and d is the shaft diameter. The terms J_{compi} are evenly distributed inertias of the components.

For the propeller the added mass of the water has been included. This has been described in [R.1, section 2.3].

The torsional stiffnesses K of the springs of the long propeller shaft follow from:

$$K = G \cdot I_p / l_k = \pi \cdot G \cdot d^2 / (32 \cdot l_k) \quad (3)$$

In this equation G is the shear modulus, I_p is the polar area moment of inertia and l_k is the length of the part of the shaft.

According to [D.6] the long propeller shaft is made of steel with a minimum tensile strength of 588 N/mm².

In order to make it possible to compare the results of the diesel-direct system with those of the electric system, input for the following components were taken equal to values used in the analysis of the electric system [R.1]:

- total nominal power (see section 2.2);
- speed ratios of gear transmissions, thus a total speed ratio of 4.9524 between engine and propeller;
- propeller data as far as possible (see section 2.3).

A difference in the nominal engine speeds in both analyses could not be avoided. This will be clarified in section 2.2.

At the time of generating the numerical model it was not known which gear transmission would be used. However, data from a comparable design [D.3] was available. The input values specified in [D.3] might not be completely correct, but it is not to be expected that specified and actual values will differ considerably.

At the time of generating the numerical model it was not known which flexible coupling would be used. Therefore, for the purpose of the calculations, a choice for the coupling was made by TNO. After consulting the engine manufacturer it was decided to choose the following coupling from the Vulkan RATO series [D.2]:

Type	: Vulkan RATO highly flexible coupling
Size	: 3113
Nominal torque	: 47 kN.m
Torsional Stiffness	: 1350 kN.m/rad

The relative damping ψ of the coupling is expressed as the ratio of the dissipated energy per cycle over the peak value of the internal elastic energy in the flexible coupling. According to the manufacturer's specifications [D.2] this relative damping $\psi = 1.5$. This is equivalent to a relative damping $\xi = \psi / (4 \cdot \pi) = 0.119$ (ratio relative to critical damping) in a resonating one-mass-spring-damper system.

The propulsion system for each propeller contains two diesel engines in parallel. In the response analyses the phase angle Φ_m between the two engines needs to be specified. However, there is not a fixed angle between the two engines. Each time an engine is uncoupled and coupled again the angle Φ_m may differ. In order to find the system response without numerous calculations (for varying phase angles Φ_m) a conservative approach (the worst case) has been used. In principle this method calculates the system response for engine number 1 separately from the response for engine number 2, after which these two responses are added. In this way the responses of both engines are summarized with the most conservative phase angle for each of the harmonics of the excitation

torques. Then the total result of the analysis will be conservative. In *practice* this principle has been realized by an adaption of the computer program, so that in only one calculation this conservative result can be obtained. In section 6.2 it will be discussed how far results are overestimated by this conservative calculation method.

2.2 Model of the diesel engines and the torsional vibration damper

The main engine particulars are:

Type	: Stork-Wärtsilä 12SW28 V-engine 50°
Nr. of cylinders	: 12
Bore	: 280 mm
Stroke	: 300 mm
Firing order	: 1 - 2 - 7 - 8 - 3 - 4 - 11 - 12 - 5 - 6 - 9 - 10
Power per cylinder between 900 and 1000 r/min	: circa 300 kW

Further detailed engine particulars are specified by the manufacturer in [D.1].

A total nominal power for one propulsion system (with two engines) has been used of 7500 kW. This value is equal to the total nominal power in the analysis of the electric system [R.1].

A nominal engine speed of 960 r/min has been used, whereas in the analysis of the electric system [R.1] the nominal engine speed is 906 r/min. This higher value of 960 r/min in this analysis was necessary in order to provide the required power of 7500 kW with a realistic mean indicated pressure.

Each engine is provided with a torsional vibration damper (also called mass damper) with the following specifications [D.1]:

Type	: Holset
Inertia of inertia ring	: 27.66 kg.m ²
Inertia of casing and cover	: 21.58 kg.m ²

In the analyses a frequency dependent 'effective inertia' of the casing and cover (the moving part of the torsional vibration damper) has been taken into account [R.2, R.4]. From preparatory calculations it had been concluded that the optimum frequency for the torsional vibration damper is 63.3 Hz (3800 c/min). All reported analyses have been based on this value for the optimally tuned damper.

Harmonic components of the tangential effort curves have been specified by the manufacturer for mean indicated pressures between 9.5 bar and 19.1 bar [D.1]. In order to perform the analyses, mean indicated pressures were required up to 23.5 bar. These were derived by extrapolation of the specified data. The amplitude was extrapolated linearly. The phase angle was taken constant outside the specified range.

The mechanical efficiency of the engine has been taken at 90 % for all engine speeds.

For engine speeds up to the nominal engine speed of 960 r/min a quadratic relationship for mean engine torque versus engine speed has been used, in accordance with the resistance of the ship's propeller (with a constant pitch). This means a third power relationship for engine power versus

engine speed. For engine speeds above 960 r/min the mean engine torque has been kept constant at the value of the engine speed at 960 r/min. This results into a linear relationship for engine power versus engine speed. This constant mean engine torque for higher speeds was applied in order to avoid unrealistic high mean indicated pressures.

Apart from the data specified above for the diesel engines the manufacturer provided data for the engine damping by means of discrete viscous rotational dampers. The damping for engine number 1 is modelled by five relative dampers (torsional dampers between masses) with a value of 3200 N.m.s/rad at the positions of K_3 , K_5 , K_7 , K_9 and K_{11} in fig. 2.2 and six absolute dampers (torsional dampers between masses and the ground) with a value of 5.5 N.m.s/rad connected to masses M_2 , M_4 , M_6 , M_8 , M_{10} and M_{12} (fig. 2.2). The damping for engine number 2 is similar. It is noticed that this damping data is given by the engine manufacturer on a non-official basis and without any guarantee for correctness. The method of derivation of this data could not be recovered. In the response analyses, this damping data is only used in calculations with the 'direct method'.

Table 2.III shows data for the crank arrangement (firing angles) of each engine [D.1].

2.3 Model of the propeller

It is noticed that the diesel-direct propulsion system contains a controllable pitch propeller whereas the electric propulsion system is mounted with a fixed pitch propeller. In practice however, the pitch will be constant for moderate and high engine speeds. Therefore the same propeller data as used for the electric system and described in [R.1, section 2.3] have been used for the diesel-direct system. However, as a consequence of a higher nominal engine speed for the diesel-direct system (explained in section 2.2), the *nominal* values for the propeller speed and the mean torque will differ about 6 % as is shown in following table.

		Electric system	Diesel-direct system
Nominal engine speed	[r/min]	906	960
Speed ratio of gear transmission	[-]	4.9542	4.9542
Nominal propeller speed	[r/min]	182.9	193.8
Nominal propeller power	[kW]	7500	7500
Nominal propeller mean torque	[kN.m]	391.6	369.6

This difference will result into similar differences in the amplitudes of the blade order excitations, because these excitations are specified as percentages of the mean torque according to [R.1, section 2.3].

These differences may be neglected when comparing the results of both analyses, because the torsional vibrations due to blade order excitations will appear to be very small in comparison with the torsional vibrations due to engine excitation torques (see chapters 4 and 5).

3 Natural frequencies, mode shapes and critical engine speeds

Table 3.I shows the natural frequencies calculated by the computer program TORPACK [R.2]. The corresponding mode shapes are shown in figures 3.1 to 3.28.

Critical engine speeds [R.2, R.4] which indicate the engine speeds at which vibratory amplitudes are in resonance are tabulated in appendix A. The corresponding values for the vector summations [R.4] are also given. The vector summation of a given harmonic excitation acting on a given mode shape is a quantitative indication for the amount of energy which a harmonic excitation supplies to the mode shape.

4 Forced vibration response by using the direct method

For the forced vibration response two different analysis methods have been used: the 'magnifier method' and the 'direct method'. In this chapter results obtained with the direct method are presented. Results using the magnifier method are presented in chapter 5. In section 6.1 the results of both methods will be compared and differences discussed.

In the direct method, the forced vibration response is calculated directly by solving the complex frequency equation of the system (without using mode shapes and natural frequencies). Further details about the direct method are specified in [R.2]. Theoretically this direct method provides an exact solution of the system response.

The internal damping of the shafts has been modelled by means of complex damping (damping proportional to displacement but in phase with the velocity of a harmonically oscillating system [R.3]).

For all springs in the system (except for spring 2 representing the flexible coupling) a complex damping $\delta = 0.004$ has been used. This is a low value (thus conservative) as commonly used for the shafts in torsional vibration analyses.

Note: this complex damping $\delta = 0.004$ is equivalent to a relative damping $\xi = \delta / 2 = 0.002$ (ratio relative to critical damping) in a resonating one-mass-spring-damper system.

All analyses have been extended up to an engine speed of 1.16 times the nominal engine speed, thus $1.16 * 960 = 1113.6$ r/min. This is according to Lloyd's Register of Shipping [R.5]. It should be noticed that this factor 1.16 is a quite severe requirement in comparison with other classification societies. For instance, Germanische Lloyd [R.6] requires only 1.05 times the nominal engine speed.

All results (except for table 4.II) apply to so-called *synthesis values*. This means that all vibratory modes and all engine excitation orders and propeller excitations have been taken into account.

Only the results of engine number 1 have been reported. This is allowed because of a high similarity between the two engines in one propulsion system. Only masses 17 and 55 (see table 2.I) are different, because of equal rotation directions of the two engines.

4.1 Stresses in the crankshaft

It should be noted that from January 1994 the specifications of Lloyd's Register of Shipping [R.5] for crankshafts have been changed drastically, in order to follow the specifications of CIMAC [R.7].

Table 4.I shows results for the maxima of vibratory torques and stresses in the shafts together with the engine speeds for which these maxima occur.

Springs 1 to 14 show the results for the maxima of vibratory torques and stresses in the crankshaft together with the engine speed for which these maxima occur.

The utmost right column of this table shows the allowable stress for the crankshaft according to Lloyd's Register of Shipping [R.5]. Because the calculation of this value requires detailed dimensions of the crankshaft, this value of 42.68 N/mm^2 has been provided by the engine manufacturer, based on the material as used today for the crankshaft of the SW28: 42CrMo4 with a

minimum tensile strength of 900 N/mm².

For an understanding of the stresses over the entire speed range, figure 4.1 shows the vibratory stress at the highest loaded part of the crankshaft (spring 6) as a function of the engine speed, together with the allowable stress.

For an interpretation of the causes of vibration table 4.II shows the contribution of each harmonic to the vibratory torques and stresses at the highest loaded part of the crankshaft (spring 6) at an engine speed of 842 r/min, for which the vibratory response has a local maximum. It can be seen that the vibratory stress at this speed is mainly caused by the harmonics of engine orders 1.5 and 4.5. Because the direct method is used, it is not possible to determine separate contributions for each vibratory mode.

As can be concluded from table 4.I and figure 4.1 all stresses in the crankshaft are below the allowable value.

4.2 Stresses in the long propeller shaft

Springs 20 to 37 in table 4.I show the results for the maxima of vibratory torques and stresses in the long propeller shaft together with the engine speed for which these maxima occur.

The utmost right column of this table shows the allowable stress according to Lloyd's Register of Shipping [R.5]. It is noticed that the specified values are for continuous running at the nominal engine speed. For engine speeds different from the nominal engine speed, higher stresses are allowed, similar to the dashed line shown in fig. 4.2.

For the determination of the allowable stresses in the long propeller shaft, the following has been taken into account:

- springs 20 to 30 are classified as 'intermediate shafts', according to section 2.6 of Lloyd's Register of Shipping [R.4];
- for spring 30 a factor of 0.75 has been applied, because of 'loose couplings' according to section 2.6.1 of Lloyd's Register of Shipping [R.4];
- springs 31 to 37 are classified as 'screwshafts', according to section 2.5 of Lloyd's Register of Shipping [R.4];
- for all shafts a material factor $k_m = 1.336$ according to section 2.8.1 of Lloyd's Register of Shipping [R.4] has been applied to account for the minimum tensile strength of 588 N/mm² of the shaft's steel.

For an understanding of the stresses over the entire speed range, figure 4.2 shows the vibratory stresses at the highest loaded part of the long propeller shaft (spring 36) as a function of the engine speed, together with the allowable stress.

As can be concluded from table 4.I and figure 4.2 all stresses in the long propeller shaft are far beyond the allowable values.

4.3 Results for the flexible coupling

Figure 4.3 shows the vibratory torque in the flexible coupling (spring 15) together with the allowable torque (12.5 kN.m) as supplied by the manufacturer [D.2]. From this figure it can be seen that the vibratory torque exceeds the allowable value for engine speeds below 320 r/min. These high torques at low engine speeds are caused largely by the critical engine speeds from mode 2 in combination with engine order 3 (critical engine speed 221 r/min, see appendix A) and mode 3 in combination with engine order 3 (critical engine speed 272 r/min). This will be discussed further in section 6.3.

4.4 Results for the gear transmission

Figure 4.4 shows the vibratory torque in the gear transmission together with the mean torque (static transmission torque). From this figure the following can be seen:

- at 1.16 times the nominal engine speed, i.e. at 1113.6 r/min, the vibratory torque reaches about 50 % (precisely: 52.4 %) of the full transmission torque (the mean torque at the nominal engine speed);
- at the critical engine speed of 842 r/min the vibratory torque reaches about one-third (precisely: 32.1 %) of the full transmission torque;
- at engine speeds below 400 r/min the vibratory torque exceeds the mean torque.

This will be discussed further in section 6.4.

5 Forced vibration response by using the magnifier method

As already mentioned at the beginning of chapter 4, two different analysis methods have been used for the forced vibration response: the 'magnifier method' and the 'direct method'. The results obtained with the direct method have been presented in the previous chapter. In this chapter results obtained with the magnifier method are presented. In section 6.1 the results of both methods will be compared and differences discussed.

In the magnifier method, the forced vibration response is calculated by using the method of modal response analysis and damping values according to Lloyd's Register of Shipping [R.5]. For small damping values the magnifier method approximates the exact solution. Further details about the magnifier method are specified in [R.2] and [R.5].

According to Lloyd's Register of Shipping [R.5], the engine magnifier has been limited to $M_E = 50$ for each vibratory mode. Thus for each mode the overall dynamic magnifier M for the system as a whole [R.5] is 50 or smaller. This means that for each vibratory mode the relative damping (ratio relative to critical damping) is larger than or equal to $\xi = 1 / (2 * M) = 0.01$.

Similar to chapter 4 all analyses have been extended up to an engine speed of 1.16 times the nominal engine speed, all results apply to *synthesis values* (except for tables 5.II and 5.III) and only the results of engine number 1 have been reported.

5.1 Stresses in the crankshaft

Similar to section 4.1, springs 1 to 14 in table 5.I show the results for the maxima of vibratory torques and stresses in the crankshaft together with the engine speed for which these maxima occur and the allowable stress for the crankshaft.

Figure 5.1 shows the vibratory stress at the highest loaded part of the crankshaft (spring 6) as a function of the engine speed, together with the allowable stress.

Table 5.II shows the contribution of each harmonic to the excitation torques and stresses of the crankshaft (spring 6) at an engine speed of 842 r/min. It appears that the vibratory stresses at this speed are mainly caused by the harmonics of engine orders 1.0, 1.5 and 4.5. Therefore in table 5.III the contributions of each vibratory mode are shown for these harmonics. It appears that the excessive stresses in the crankshaft are mainly caused by harmonics of engine orders 1.5 and 4.5 acting on modes 7 and 8. These modes represent engine vibrations, as can be seen from figures 3.7 and 3.8.

As can be concluded from table 5.I and figure 5.1 all stresses in the crankshaft are below the allowable value.

5.2 Stresses in the long propeller shaft

Springs 20 to 37 in table 5.I show the results for the maxima of vibratory torques and stresses in the long propeller shaft together with the engine speed for which these maxima occur and the allowable stresses for continuous running at the nominal engine speed. The allowable stresses have been determined as described in section 4.2.

Figure 5.2 shows the vibratory stresses at the highest loaded part of the long propeller shaft (spring 36) as a function of the engine speed, together with the allowable stress.

As can be concluded from table 5.I and figure 5.2 all stresses in the long propeller shaft are far beyond the allowable values.

5.3 Results for the flexible coupling

Figure 5.3 shows the vibratory torque in the flexible coupling (spring 15) together with the allowable torque. Identical conclusions as in section 4.3 can be drawn. This will be discussed further in section 6.3.

5.4 Results for the gear transmission

Figure 5.4 shows the vibratory torque in the gear transmission together with the mean torque. Identical conclusions as in section 4.4 can be drawn (the precise percentages are 53.2 % at 1113.6 r/min and 33.5 % at 842 r/min).

This will be discussed further in section 6.4.

6 Discussion of results

6.1 Comparison of the direct method with the magnifier method

Figure 6.1 shows the vibratory stress at the highest loaded part of the crankshaft (spring 6) obtained with the direct method as well as with the magnifier method. As can be seen stresses in this spring obtained with both methods correspond well.

Figure 6.2 shows the vibratory stress at the highest loaded part of the long propeller shaft (spring 36) for both methods. From this figure it can be seen that peak values obtained with the direct method appear to be much larger. These differences are caused by the differences in the assumed damping values for both methods: for the direct method a relative damping $\xi = 0.002$ (beginning of chapter 4) and for the magnifier method a relative damping larger than or equal to $\xi = 0.01$ (beginning of chapter 5).

Figures 6.3 and 6.4 show the vibratory torques in the flexible coupling (spring 15) and in the gear transmission. As can be seen, results for vibratory torques obtained with both methods correspond very well.

6.2 Effect of phase angle between the two engines

In this section analyses are presented which investigate how far results are overestimated by the conservative calculation method for the phase angle between the two engines as described in section 2.1.

Using several values for the angle Φ_m between the two engines, analyses have been performed in which the phase angles of the engine excitation torques have been applied exactly.

Table 6.I shows the vibratory stresses and torques at the highest loaded part of the crankshaft (spring 6) as a function of the phase angle Φ_m at an engine speed of 842 r/min. These analyses were performed using the magnifier method, however this choice is not essential (the direct method would lead to similar conclusions).

It can be seen that the vibratory stresses in the crankshaft are nearly the same for different phase angles.

Using the conservative calculation method (as used for the results presented in chapters 4 and 5), at 842 r/min in spring 6 a vibratory stress of 37.1 N/mm^2 was found for the magnifier method (in principle this can be seen in fig. 5.1, not in table 5.I). This is only 1.9 % higher than the lowest value reported in table 6.I.

From the analysis above it is concluded that the conservative calculation method for taking into account the unknown phase angle between the two engines has negligible effects on the calculated results.

6.3 Torques in the flexible coupling

As concluded in sections 4.3 and 5.3 the vibratory torque in the flexible coupling exceeds the allowable value for engine speeds below 320 r/min. Therefore, provisions must be taken that no continuous running will occur for engine speeds below 320 r/min.

If these low engine speeds cannot be avoided, it might be possible to solve the problem by using a different flexible coupling. The Vulkan RATO coupling can be obtained with four different torsional stiffnesses, ranging from 360 kN.m/rad to 1350 kN.m/rad. All analyses in this study have been performed with the torsional stiffness of 1350 kN.m/rad. A lower stiffness will lower the frequency of the vibratory modes 2 and 3 and because the high torques in the flexible coupling are largely caused by modes 2 and 3 (see section 4.3), this will lower the appropriate critical engine speeds. For a definite answer additional calculations with different flexible couplings are required.

It is important to notice that the great length of the propeller shaft is not causing these high vibratory torques at low engine speeds.

6.4 Torques in the gear transmission

In sections 4.4 and 5.4 relatively high vibratory torques in the gear transmission were noticed.

Lloyd's Register of Shipping [R.5] recommends that the vibratory torque in a gear transmission should not, in general, exceed one-third of the full transmission torque at critical engine speeds near the maximum engine speed.

Because the vibratory torque of 50 % occurs only at very high engine speeds (1.16 times the nominal engine speed) and the 33 % is just within the one-third limit, no problems from the gear transmission are to be expected for engine speeds near the nominal engine speed.

Moreover, Lloyd's Register's specification of one-third is only an 'in general recommendation'. Furthermore, the results in this study apply to so-called *synthesis values* (see the beginning of chapter 4), whereas torsional vibration calculations are often based on the results of calculations with only one mode and one engine order at a time, which in general will lead to lower values.

A more severe condition in the gear transmission occurs at lower engine speeds. As concluded in sections 4.4 and 5.4 the vibratory torque exceeds the mean torque for engine speeds below 400 r/min.

For engine speeds different from engine speeds near the maximum engine speed there are no requirements or recommendations regarding gear transmissions in Lloyd's Register of Shipping [R.5]. In practice it is recommended that for these engine speeds (i.e. engine speeds different from speeds near the maximum engine speed), the vibratory torque should not exceed 70 % of the mean torque. From figures 4.4 and 5.4 it can be seen that for engine speeds above 550 r/min this requirement has been fulfilled. For lower rotor speeds this is not the case.

This means a serious danger for so-called *gear hammer* at engine speeds below 550 r/min. Therefore, provisions must be taken that no continuous running will occur for engine speeds below 550 r/min. Similar to the conclusion in section 6.3, it might be possible to solve this problem by using a flexible coupling with a lower torsional stiffness. For a definite answer additional calculations with different flexible couplings are required.

Similar to the conclusion in section 6.3, it is important to notice that the great length of the propeller shaft is not causing these high vibratory torques in the gear transmission.

7 Comparison of the electric system with the diesel-direct system

In table 7.I the maxima of vibratory stresses in the long propeller shaft as found in this study are compared with the results of the electric system [R.1]. From this it is concluded that the stresses in the long propeller shaft of the electric system are 1/3 to 1/5 of those of the diesel-direct system. This can also be seen from a comparison of the dashed line of fig. 5.1 in [R.1] and the solid line of fig. 6.2 in this report. Only the results in this report obtained with the *direct* method are comparable with the results of the electric system, because the electric system has been analyzed only by using this direct method (with equal values for material damping). It should be noted that for the diesel-direct system as well as for the electric system the stresses in the long propeller shaft are low in comparison with the allowable stresses (see section 5.2).

A comparison of the vibratory torques in the flexible couplings shows the following maximum vibratory torques:

Diesel-direct system	:	27.7 kN.m (table 4.I, spring 15)
Electric system	:	2.64 kN.m [R.1, table 5.IV]

Thus, the vibratory torques in the flexible coupling of the electric system are about 1/10 of those of the diesel-direct system, despite the fact that the flexible coupling of the diesel-direct system is loaded by only half of the total torque (because of two engines, see fig. 2.1).

For a comparison of the vibratory torques in the gear transmissions fig. 4.4 should be compared with [R.1, fig. 5.3]. Because in fig. 4.4 the torque of only one engine is shown (but expressed as a torque on the propeller shaft), the result in this figure 4.4 must be multiplied by a factor two for comparison with [R.1, fig. 5.3]. This results into the following maximum vibratory torques:

Diesel-direct system	:	54 kN.m (fig. 4.4)
Electric system	:	2.4 kN.m [R.1, fig. 5.3]

Thus, the vibratory torques in the gear transmission of the electric system are about 1/20 of those of the diesel-direct system.

Summarizing it is concluded that torsional vibrations in the propulsion system of the electric system are significantly lower than those in the diesel-direct system: 1/3 to 1/5 for the vibratory stresses in the long propeller shaft, 1/10 for the vibratory torques in the flexible coupling and 1/20 for the vibratory torques in the gear transmission.

8 Conclusions

- 8.1 From torsional vibration analyses on the diesel-direct propulsion system of the Amphibious Transport Ship (ATS) it is found that for engine speeds between 550 r/min up to the maximum engine speed the vibratory torques and stresses in the system are within the limits as specified by Lloyd's Register of Shipping [R.5].
- 8.2 For engine speeds below 550 r/min there is a serious danger for so-called *gear hammer* in the gear transmission, because the vibratory torque exceeds 70 % of the mean torque. Therefore provisions must be taken to avoid continuous running at engine speeds below 550 r/min.
- 8.3 For engine speeds below 320 r/min the vibratory torque in the flexible coupling exceeds the allowable value as specified by the engine manufacturer [D.2].
- 8.4 The use of a flexible coupling with a lower torsional stiffness might solve the problems as indicated in conclusions 8.2 and 8.3. For a definite answer additional calculations with different flexible couplings will be necessary .
- 8.5 The great length of the propeller shaft is not the cause of the high vibratory torques as mentioned in conclusions 8.2 and 8.3.
- 8.6 A noticeable phenomenon resulting from the great length of the propeller shaft is that relatively large vibratory rotations occur locally in the long shaft. These vibrations are almost solely controlled by internal damping of the shaft. However, stresses resulting from these relatively large vibrations, are low.
- 8.7 From a comparison of the electric system [R.1] with the diesel-direct system it is concluded that torsional vibrations in the electric system are significantly lower than those in the diesel-direct system: 1/3 to 1/5 for the vibratory stresses in the long propeller shaft, 1/10 for the vibratory torques in the flexible coupling and 1/20 for the vibratory torques in the gear transmission.
- 8.8 Following conclusions merely concern the torsional vibration analysis *method*. They are of limited importance for the analysis of the propeller shafting system.
 - 8.8.1 From preparatory calculations it has been concluded that the optimum frequency for the torsional vibration damper is 63.3 Hz (3800 c/min). All final analyses have been based on this value for the optimally tuned damper.
 - 8.8.2 For the analyses two different methods have been used: the so-called *direct method* and the *magnifier method* (according to Lloyd's Register of Shipping). Results obtained with both methods correspond very well, except for the vibratory stresses in the long propeller shaft. These differences are due to differences in the assumed minimum values for the damping in the models for both types of analyses.
 - 8.8.3 In order to account for the unknown phase angle between the two diesel engines, a conservative calculation method has been applied. This method has been validated with calculations in which several phase angles were modelled exactly. It was found that the overestimation due to the conservative method is negligible small (1.9 %).

9 References

General references

- [R.1] Brockhoff, H.S.T. and Lemmen, P.P.M.
Torsional vibration analysis of a long propeller shaft system driven by an electric motor
TNO report 95-CMC-R0614, 1995
- [R.2] Brockhoff, H.S.T.
TORPACK user's manual
TNO report B-91-0493 (in Dutch), 1991
- [R.3] Craigh, R.R.
Structural dynamics - An introduction to computer methods
John Wiley & Sons, 1981
- [R.4] Den Hartog, J.P.
Mechanical Vibrations
4th edition
McGraw-Hill Book Company, 1956
- [R.5] Lloyd's Register of Shipping
Rules and Regulations for the Classification of Ships
Part 5: Main and Auxiliary Machinery
Chapter 2: Oil engines
Chapter 6: Shaft Vibration and Alignment
Lloyd's Register of Shipping, January 1994
- [R.6] Germanische Lloyd
Klassifikations- und Bauvorschriften
I - Schiffstechnik
Teil 1 - Seeschiffe
Kapitel 2 - Maschinenanlagen
Abschnitt 16 - Drehschwingungen
Germanischer Lloyd, 1992
- [R.7] CIMAC UR M53
Calculation of crank shafts for internal combustion engines
CIMAC, date unknown

Documentation concerning the diesel engines, flexible couplings and gear transmissions

- [D.1] Dijk, K. van
Gegevens 12SW28 voor torsietrillingsanalyse
Stork-Wärtsilä Diesel, 1993 (handwritten, in Dutch)
- [D.2] *RATO Highly Flexible Couplings*
Vulkan, Publication No. 0587/2
- [D.3] *Vibration analysis data of the gear transmission of the AOR*
Royal Schelde, 18-05-1992

Documentation concerning the long propeller shaft

- [D.4] *General arrangement shafting & reduction diesel-direct*
BAZAN/NEVESBU, NEVESBU drawing no. 1610-01, May 1993
- [D.5] *Project definition - Shaft bracket arrangement*
BAZAN/NEVESBU, NEVESBU drawing no. 1610-01, July 1993
- [D.6] *Shaftline dimension report*
BAZAN/NEVESBU, NEVESBU document no. 2400.11, 5th March 1993
- [D.7] *Report on shafting vibration calculation (whirling)*
BAZAN/NEVESBU, NEVESBU document no. 2400.81, 27th May 1993

Documentation concerning the propeller

- [D.8] *ATS diesel electric - Powering estimation report*
BAZAN/NEVESBU, NEVESBU document no. 0514.11, 26th August 1993

Tables

Description	Mass nr.	Inertia [kg.m ²]	Description	Mass nr.	Inertia [kg.m ²]
Damper 1 engine number 1	1	23.86	M ₁₂ shaft	31	110.70
Cylinder 1 engine number 1	2	8.75	M ₁₃ shaft	32	64.02
Cylinder 2 engine number 1	3	8.75	M ₁₄ shaft	33	64.02
Cylinder 3 engine number 1	4	8.75	M ₁₅ shaft	34	64.02
Cylinder 4 engine number 1	5	8.75	M ₁₆ shaft	35	64.02
Cylinder 5 engine number 1	6	8.75	M ₁₇ shaft	36	64.02
Cylinder 6 engine number 1	7	8.75	M ₁₈ shaft	37	67.63
Cylinder 7 engine number 1	8	8.75	Propeller + M ₁₉ shaft	38	7850.10
Cylinder 8 engine number 1	9	8.75	Damper 1 engine number 2	39	23.86
Cylinder 9 engine number 1	10	8.75	Cylinder 1 engine number 2	40	8.75
Cylinder 10 engine number 1	11	8.75	Cylinder 2 engine number 2	41	8.75
Cylinder 11 engine number 1	12	8.75	Cylinder 3 engine number 2	42	8.75
Cylinder 12 engine number 1	13	8.75	Cylinder 4 engine number 2	43	8.75
Gear engine number 1	14	8.80	Cylinder 5 engine number 2	44	8.75
Flywheel + outer part flex. cpl.	15	68.01	Cylinder 6 engine number 2	45	8.75
Flange	16	41.90	Cylinder 7 engine number 2	46	8.75
Ortlinghaus clutch	17	164.10	Cylinder 8 engine number 2	47	8.75
Input wheel gear transmission	18	197.60	Cylinder 9 engine number 2	48	8.75
Output wheel gear transmission	19	2247.30	Cylinder 10 engine number 2	49	8.75
Output shaft g. tr. + M ₁ shaft	20	208.70	Cylinder 11 engine number 2	50	8.75
M ₂ shaft	21	41.26	Cylinder 12 engine number 2	51	8.75
M ₃ shaft	22	41.26	Gear engine number 2	52	8.80
M ₄ shaft	23	41.26	Flywh. + outer part fl. c.	53	68.01
M ₅ shaft	24	41.26	Flange	54	41.90
M ₆ shaft	25	41.26	Ortlinghaus clutch	55	221.90
M ₇ shaft	26	41.26	Input wheel gear tr.	56	197.60
M ₈ shaft	27	41.26	Oil input gear tr.	57	296.60
M ₉ shaft	28	41.26	Ring vibration damper	58	27.66
M ₁₀ shaft	29	41.26	Ring vibration damper	59	27.66
M ₁₁ shaft	30	136.92			

Table 2.I Rotational mass moments of inertia used in the analyses

Spring number	Connected masses	Stiffness [N.m/rad]	Diameter [mm]	Spring number	Connected masses	Stiffness [N.m/rad]	Diameter [mm]
1	1 - 2	7.26E+07	220	29	29 - 30	2.12E+07	325
2	2 - 3	1.89E+08	220	30	30 - 31	3.58E+07	350/130 ¹⁾
3	3 - 4	4.48E+07	220	31	31 - 32	3.39E+07	370/130 ¹⁾
4	4 - 5	1.89E+08	220	32	32 - 33	3.39E+07	370/130 ¹⁾
5	5 - 6	4.48E+07	220	33	33 - 34	3.39E+07	370/130 ¹⁾
6	6 - 7	1.89E+08	220	34	34 - 35	3.39E+07	370/130 ¹⁾
7	7 - 8	4.48E+07	220	35	35 - 36	3.39E+07	370/130 ¹⁾
8	8 - 9	1.89E+08	220	36	36 - 37	3.39E+07	370/130 ¹⁾
9	9 - 10	4.48E+07	220	37	37 - 38	1.19E+08	410/130 ¹⁾
10	10 - 11	1.89E+08	220	39	39 - 40	7.26E+07	220
11	11 - 12	4.48E+07	220	40	40 - 41	1.89E+08	220
12	12 - 13	1.89E+08	220	41	41 - 42	4.48E+07	220
13	13 - 14	4.48E+07	220	42	42 - 43	1.89E+08	220
14	14 - 15	1.58E+08	250	43	43 - 44	4.48E+07	220
15	15 - 16	1.35E+06	-	44	44 - 45	1.89E+08	220
16	16 - 17	1.02E+07	-	45	45 - 46	4.48E+07	220
17	17 - 18	3.80E+08	-	46	46 - 47	1.89E+08	220
19	19 - 20	7.19E+08	-	47	47 - 48	4.48E+07	220
20	20 - 21	2.12E+07	325	48	48 - 49	1.89E+08	220
21	21 - 22	2.12E+07	325	49	49 - 50	4.48E+07	220
22	22 - 23	2.12E+07	325	50	50 - 51	1.89E+08	220
23	23 - 24	2.12E+07	325	51	51 - 52	4.48E+07	220
24	24 - 25	2.12E+07	325	52	52 - 53	1.58E+08	250
25	25 - 26	2.12E+07	325	53	53 - 54	1.35E+06	-
26	26 - 27	2.12E+07	325	54	54 - 55	1.02E+07	-
27	27 - 28	2.12E+07	325	55	55 - 56	3.80E+08	-
28	28 - 29	2.12E+07	325	57	57 - 19	8.00E+08	-

¹⁾ Hollow shaft

Table 2.II Input of torsional springs

Cylinder	Firing angle [degrees]	Cylinder	Firing angle [degrees]
1	0.0	7	120.0
2	50.0	8	170.0
3	240.0	9	600.0
4	290.0	10	650.0
5	480.0	11	360.0
6	530.0	12	410.0

Table 2.III Crank arrangement

Mode	Frequency [Hz]	Frequency [c/min]	Mode	Frequency [Hz]	Frequency [c/min]
1	2.4	141	15	140.9	8455
2	11.1	664	16	146.8	8807
3	13.6	815	17	146.8	8807
4	19.5	1171	18	162.7	9760
5	39.0	2338	19	168.5	10109
6	60.6	3636	20	185.6	11137
7	63.4	3805	21	199.7	11984
8	63.6	3813	22	203.8	12230
9	74.9	4492	23	217.2	13034
10	83.0	4977	24	222.7	13363
11	86.6	5197	25	225.5	13527
12	99.5	5970	26	225.7	13539
13	110.9	6653	27	238.2	14293
14	131.9	7911	28	238.2	14293

Table 3.I Natural frequencies

Spring number	Engine speed [r/min]	Vibratory torque [N.m]	Vibratory stress [N/mm ²]	Allowable stress ¹⁾ [N/mm ²]
1	842.4	19200	9.2	42.68
2	939.4	45600	21.8	42.68
3	1113.6	59700	28.5	42.68
4	1113.6	63900	30.6	42.68
5	1113.6	75200	36.0	42.68
6	1113.6	78700	37.7	42.68
7	842.4	68600	32.8	42.68
8	842.4	69100	33.0	42.68
9	1113.6	71000	34.0	42.68
10	879.0	71000	33.9	42.68
11	842.4	62500	29.9	42.68
12	842.4	47200	22.6	42.68
13	842.4	25400	12.2	42.68
14	842.4	22600	7.4	42.68
15	221.4	27700	-	-
16	221.4	28100	-	-
17	221.4	27500	-	-
19	195.1	34100	-	-
20	195.1	34800	5.2	26.6
21	195.1	33900	5.0	26.6
22	195.1	32100	4.8	26.6
23	195.1	29300	4.4	26.6
24	195.1	25800	3.8	26.6
25	195.1	21500	3.2	26.6

¹⁾ Allowable stresses for continuous running at nominal engine speed of 960 r/min

Table 4.I (see also next page) Maxima of vibratory torques and stresses, direct method

Spring number	Engine speed [r/min]	Vibratory torque [N.m]	Vibratory stress [N/mm ²]	Allowable stress ¹⁾ [N/mm ²]
26	195.1	16600	2.5	26.6
27	389.7	12200	1.8	26.6
28	389.7	8790	1.3	26.6
29	389.7	7410	1.1	26.6
30	195.1	22200	2.7	19.7
31	195.1	36800	3.8	18.3
32	195.1	44200	4.5	18.3
33	195.1	50400	5.1	18.3
34	195.1	55200	5.6	18.3
35	195.1	58400	6.0	18.3
36	195.1	60100	6.1	18.3
37	195.1	60100	4.5	17.6

¹⁾ Allowable stresses for continuous running at nominal engine speed of 960 r/min

Table 4.I (continued) Maxima of vibratory torques and stresses, direct method

Excitation torque	Vibratory torque [N.m]	Vibratory stress [N/mm ²]
Prop. 1st blade	17.8	0.0
Prop. 2nd blade	0.3	0.0
Engine order 0.5	7460.0	3.6
Engine order 1.0	11900.0	5.7
Engine order 1.5	37300.0	17.9
Engine order 2.0	416.0	0.2
Engine order 2.5	7350.0	3.5
Engine order 3.0	2630.0	1.3
Engine order 3.5	4040.0	1.9
Engine order 4.0	3180.0	1.5
Engine order 4.5	18300.0	8.8
Engine order 5.0	2380.0	1.1
Engine order 5.5	3540.0	1.7
Engine order 6.0	3350.0	1.6
Engine order 6.5	888.0	0.4
Engine order 7.0	1040.0	0.5
Engine order 7.5	588.0	0.3
Engine order 8.0	736.0	0.4
Engine order 8.5	49.3	0.0
Engine order 9.0	821.0	0.4
Engine order 9.5	173.0	0.1
Engine order 10.0	290.0	0.1
Engine order 10.5	229.0	0.1
Engine order 11.0	107.0	0.1
Engine order 11.5	123.0	0.1
Engine order 12.0	134.0	0.1

Table 4.II Contribution of each harmonic for the crankshaft (spring 6) at 842 r/min, direct method

Spring number	Engine speed [r/min]	Vibratory torque [N.m]	Vibratory stress [N/mm ²]	Allowable stress ¹⁾ [N/mm ²]
1	842.4	20400	9.7	42.68
2	939.4	45900	21.9	42.68
3	842.4	62500	29.9	42.68
4	1113.6	66700	31.9	42.68
5	1113.6	77700	37.2	42.68
6	1113.6	80100	38.3	42.68
7	842.4	72400	34.6	42.68
8	842.4	72800	34.8	42.68
9	842.4	74300	35.5	42.68
10	842.4	74900	35.8	42.68
11	842.4	65800	31.5	42.68
12	842.4	50900	24.4	42.68
13	842.4	28300	13.5	42.68
14	842.4	25100	8.2	42.68
15	221.4	28800	-	-
16	221.4	29200	-	-
17	221.4	28500	-	-
19	389.7	9740	-	-
20	389.7	9820	1.5	26.6
21	389.7	9570	1.4	26.6
22	195.1	9060	1.3	26.6
23	195.1	8410	1.2	26.6
24	195.1	7550	1.1	26.6
25	195.1	6500	1.0	26.6

¹⁾ Allowable stresses for continuous running at nominal engine speed of 960 r/min

Table 5.I (see also next page) Maxima of vibratory torques and stresses, magnifier method

Spring number	Engine speed [r/min]	Vibratory torque [N.m]	Vibratory stress [N/mm ²]	Allowable stress ¹⁾ [N/mm ²]
26	195.1	5290	0.8	26.6
27	139.0	5490	0.8	26.6
28	139.0	5740	0.9	26.6
29	139.0	5970	0.9	26.6
30	195.1	6760	0.8	19.7
31	195.1	10600	1.1	18.3
32	195.1	12500	1.3	18.3
33	195.1	14100	1.4	18.3
34	195.1	15400	1.6	18.3
35	195.1	16300	1.7	18.3
36	195.1	16700	1.7	18.3
37	195.1	16700	1.2	17.6

¹⁾ Allowable stresses for continuous running at nominal engine speed of 960 r/min

Table 5.I (continued) Maxima of vibratory torques and stresses, magnifier method

Excitation torque	Vibratory torque [N.m]	Vibratory stress [N/mm ²]
Prop. 1st blade	18.6	0.0
Prop. 2nd blade	0.3	0.0
Engine order 0.5	7330.0	3.5
Engine order 1.0	12000.0	5.8
Engine order 1.5	37300.0	17.9
Engine order 2.0	416.0	0.2
Engine order 2.5	7370.0	3.5
Engine order 3.0	3090.0	1.5
Engine order 3.5	4050.0	1.9
Engine order 4.0	3130.0	1.5
Engine order 4.5	22200.0	10.6
Engine order 5.0	2610.0	1.2
Engine order 5.5	3590.0	1.7
Engine order 6.0	3600.0	1.7
Engine order 6.5	917.0	0.4
Engine order 7.0	1090.0	0.5
Engine order 7.5	632.0	0.3
Engine order 8.0	716.0	0.3
Engine order 8.5	82.0	0.0
Engine order 9.0	832.0	0.4
Engine order 9.5	151.0	0.1
Engine order 10.0	345.0	0.2
Engine order 10.5	299.0	0.1
Engine order 11.0	94.4	0.0
Engine order 11.5	120.0	0.1
Engine order 12.0	134.0	0.1

Table 5.II Contribution of each harmonic for the crankshaft (spring 6) at 842 r/min, magnifier method

Mode	Order 1.0	Order 1.5	Order 4.5
1	0.0	0.0	0.0
2	0.0	0.1	0.0
3	0.1	0.1	0.0
4	0.0	0.0	0.0
5	0.0	0.0	0.0
6	0.2	0.0	0.0
7	0.0	5.8	5.9
8	0.1	5.5	5.7
9	0.0	0.0	0.0
10	0.0	0.1	0.0
11	0.0	0.0	0.0
12	0.0	0.0	0.0
13	0.0	0.0	0.0
14	0.0	0.0	0.0
15	1.7	0.8	0.0
16	1.5	0.7	0.2
17	0.0	0.0	0.2
18	0.0	0.0	0.0
19	0.0	0.0	0.0
20	0.0	0.0	0.0
21	0.0	0.0	0.0
22	0.0	0.0	0.0
23	0.0	0.0	0.0
24	0.0	0.0	0.0
25	0.0	0.0	0.0
26	0.0	0.0	0.0
27	1.0	2.5	0.3
28	0.7	1.8	0.2

Table 5.III Modal contributions to vibratory stresses in the crankshaft (spring 6) for harmonics of engine orders 1.0, 1.5 and 4.5 at an engine speed of 842 r/min (stresses in N/mm²), magnifier method

Phase angle [degrees]	Vibratory torque [N.m]	Vibratory stress [N/mm ²]
0.0	76452	36.6
10.0	76297	36.5
20.0	76215	36.5
30.0	76188	36.4
40.0	76332	36.5
50.0	76714	36.7
60.0	76962	36.8
70.0	76871	36.8
80.0	76545	36.6
90.0	76303	36.5
100.0	76166	36.4
110.0	76145	36.4
120.0	76349	36.5
130.0	76766	36.7
140.0	76982	36.8
150.0	76830	36.7
160.0	76445	36.6
170.0	76184	36.4
180.0	76063	36.4

Table 6.I Vibratory torques and stresses in the crankshaft (spring 6) for different phase angles between the two engines at an engine speed of 842 r/min, magnifier method

Diesel-direct		Electric		Diesel-direct divided by electric
Spring number	Vibratory stress [N/mm ²]	Spring number	Vibratory stress [N/mm ²]	
6	1.9	20	5.2	2.5
7	1.9	21	5.0	2.6
8	1.9	23	4.4	2.3
9	1.4	25	3.2	2.3
10	1.1	27	1.8	1.6
11	1.1	29	1.1	1.0
12	1.1	31	3.8	3.5
13	1.1	33	5.1	4.6
14	1.1	35	6.0	5.5
15	1.1	36	6.1	5.5
16	0.8	37	4.5	5.6

Table 7.I Maxima of vibratory stresses in the long propeller shaft compared for diesel-direct system and electric system

Figures

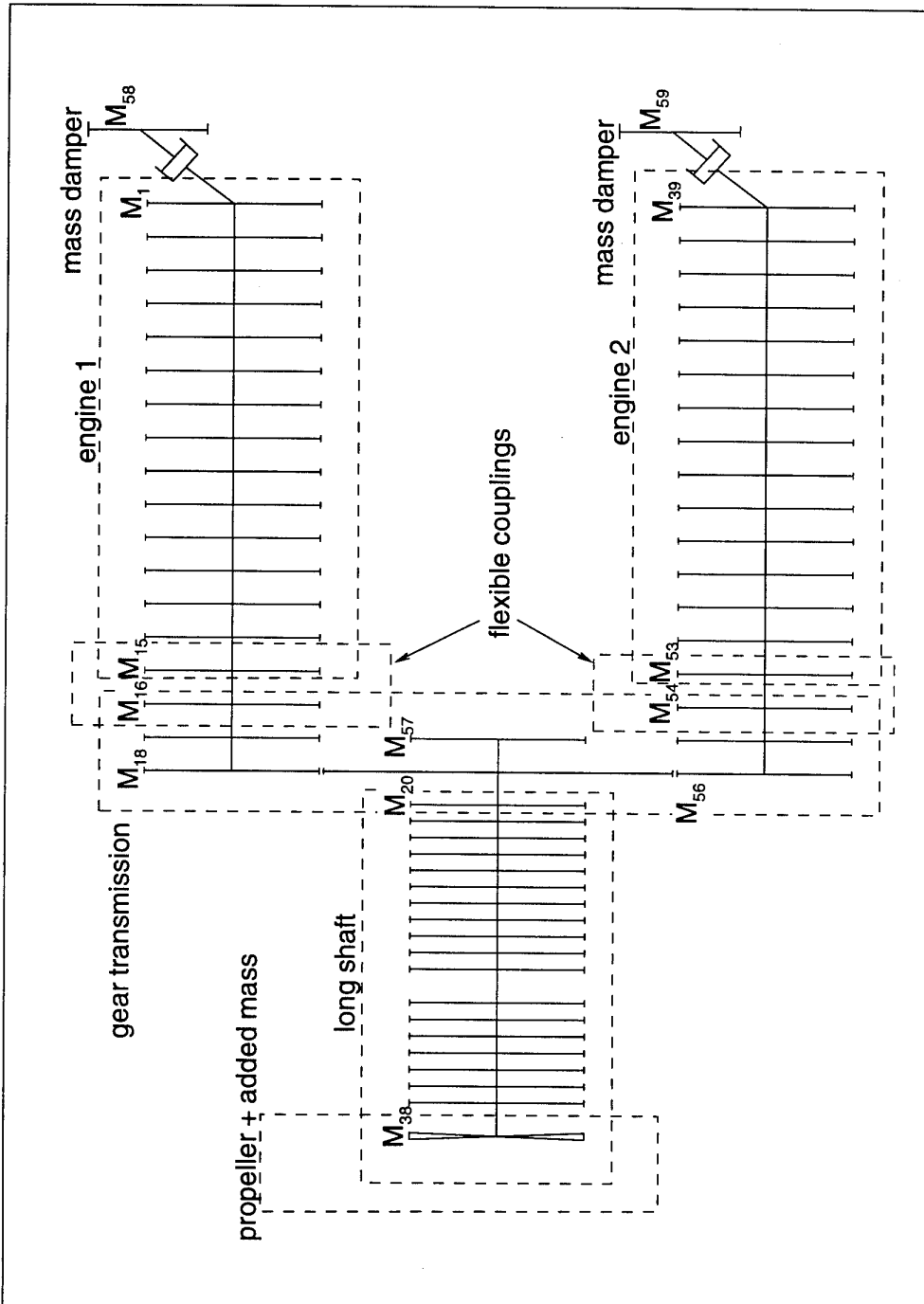

Figure 2.1 Schematic drawing of the model used in the torsional vibration analyses of the diesel-direct propulsion system

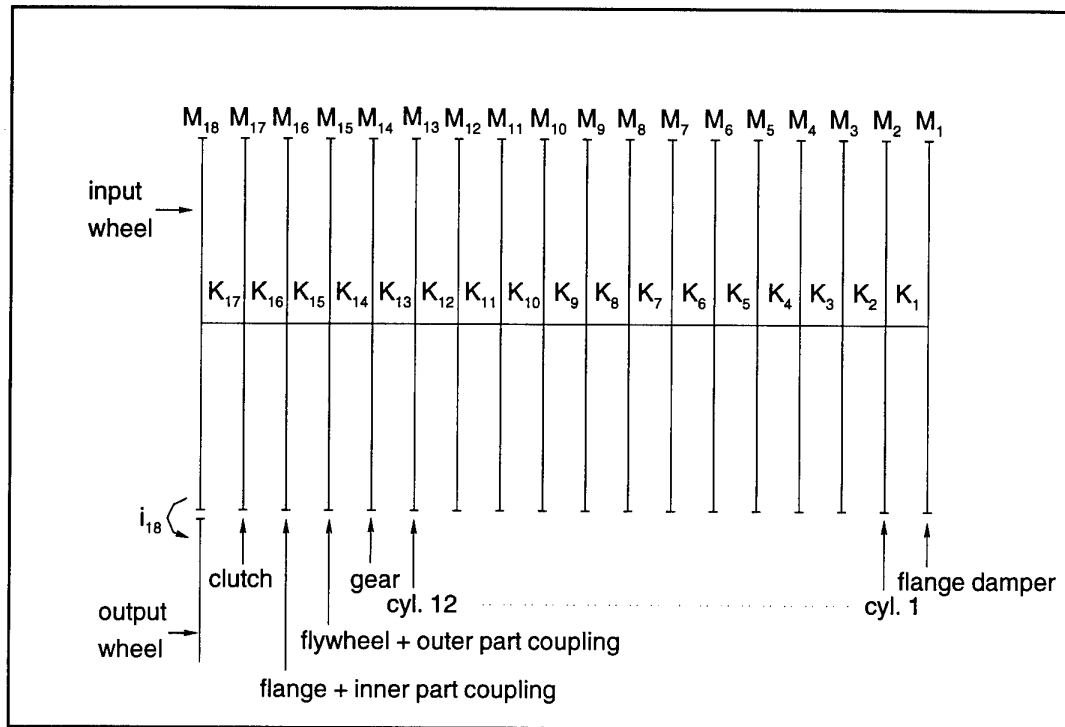

Figure 2.2 Schematic drawing of the model of engine number 1

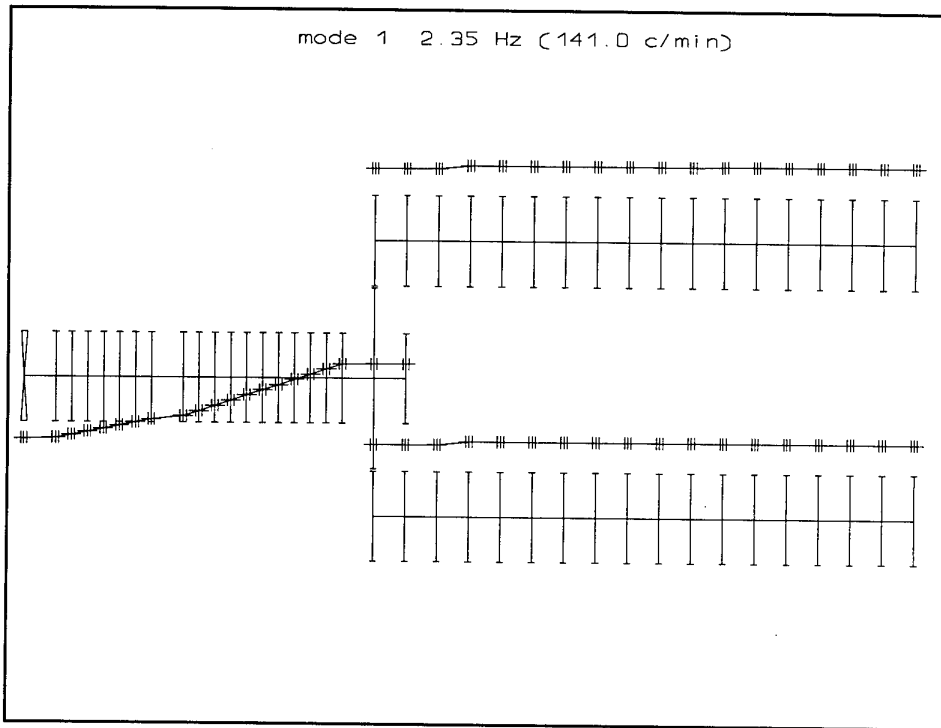

Figure 3.1 Mode 1

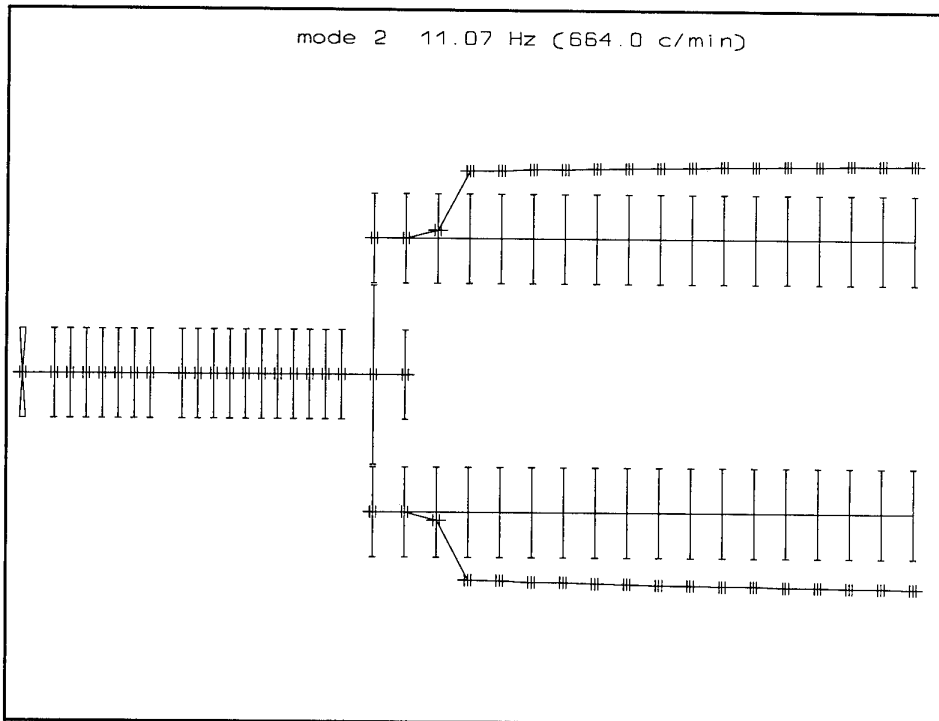

Figure 3.2 Mode 2

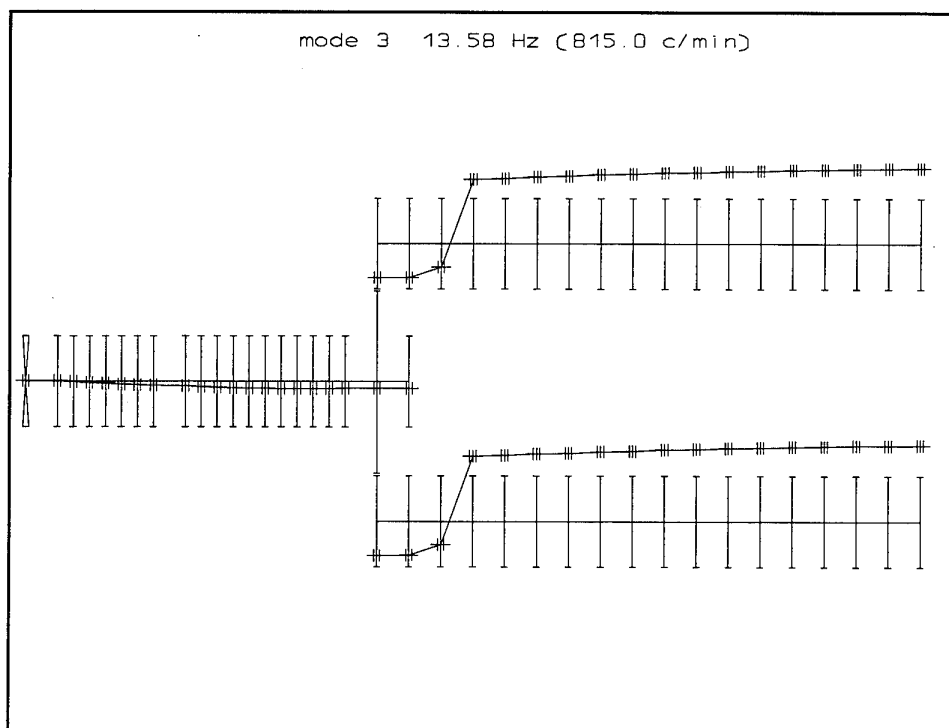

Figure 3.3 Mode 3

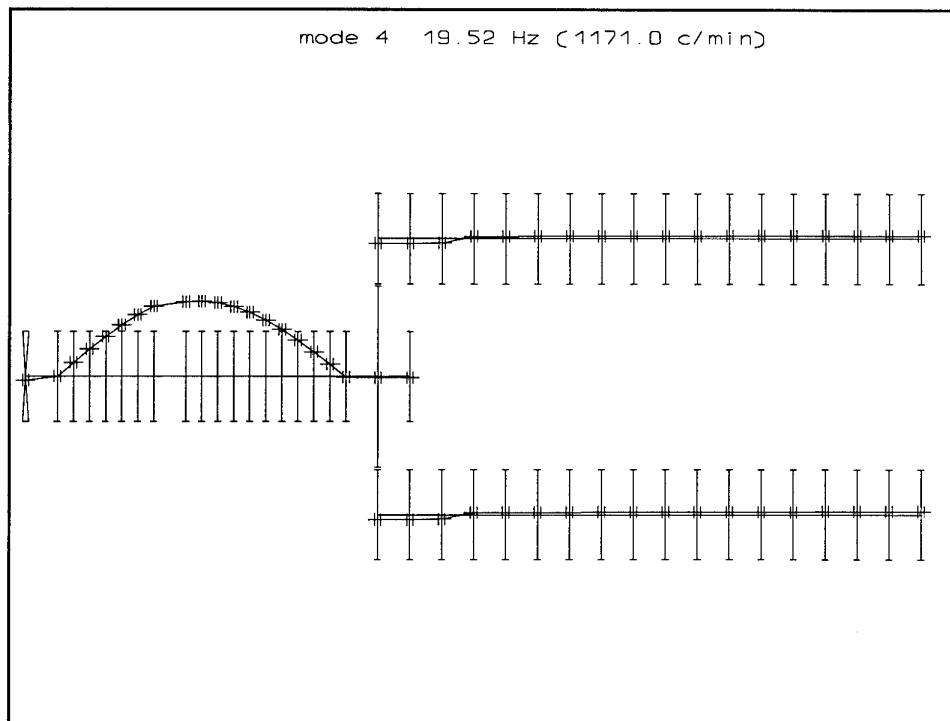

Figure 3.4 Mode 4

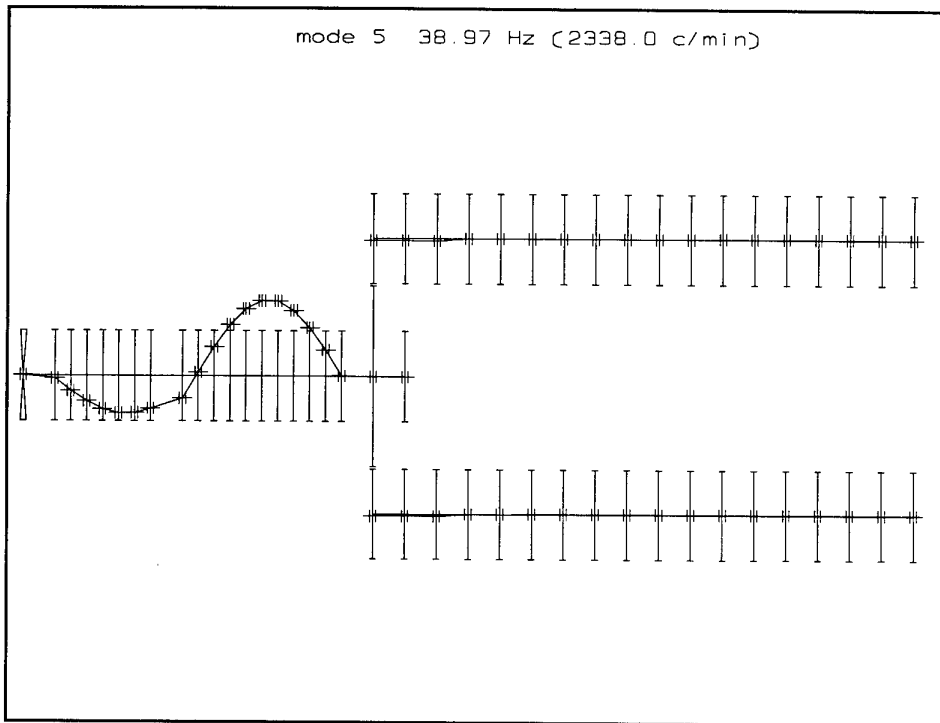

Figure 3.5 Mode 5

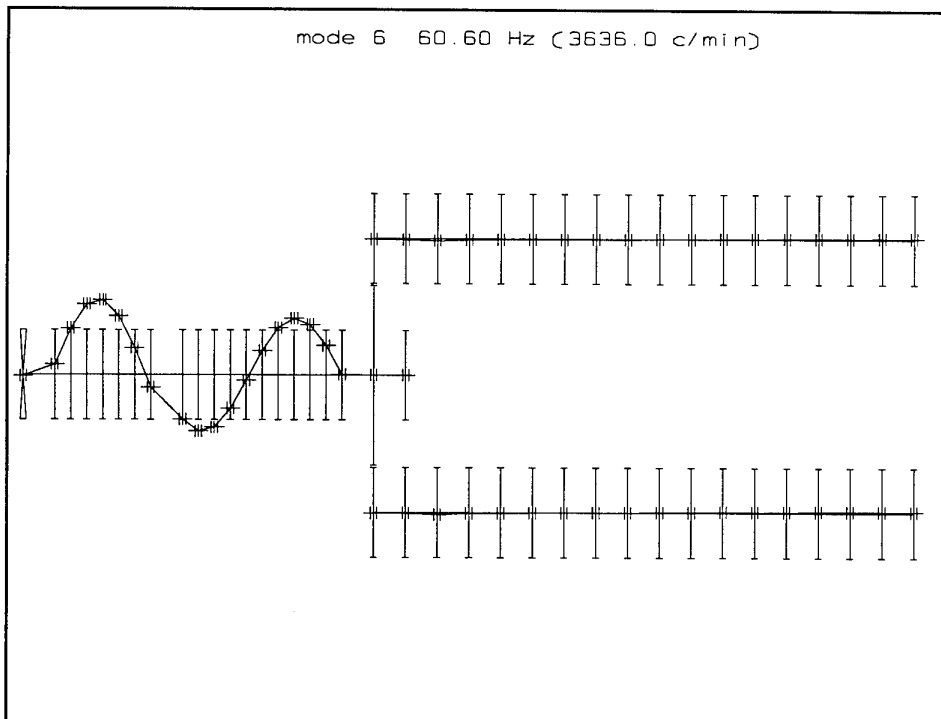

Figure 3.6 Mode 6

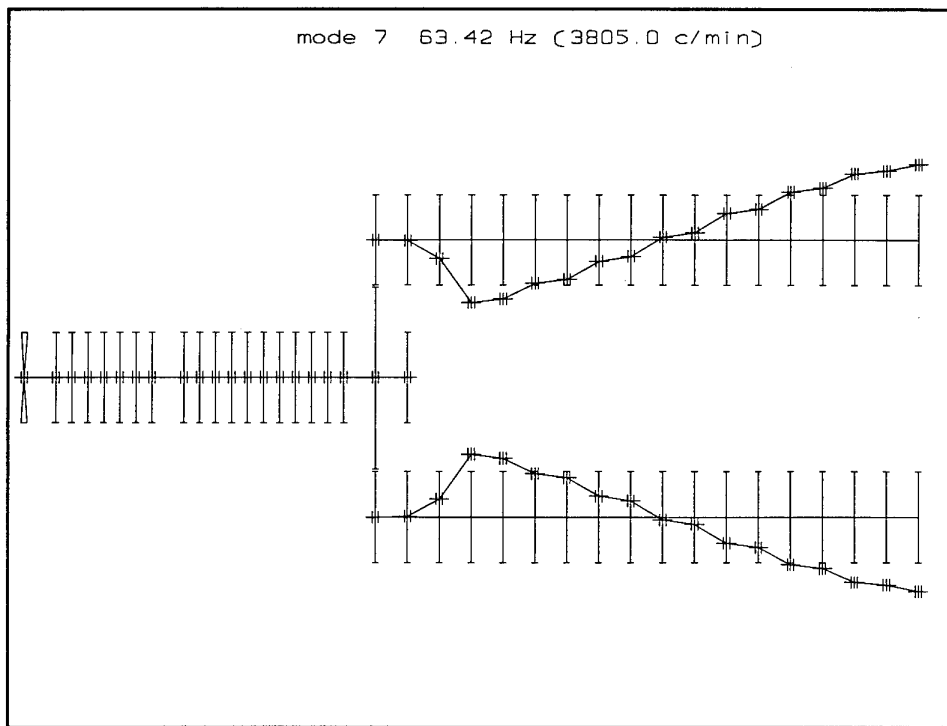

Figure 3.7 Mode 7

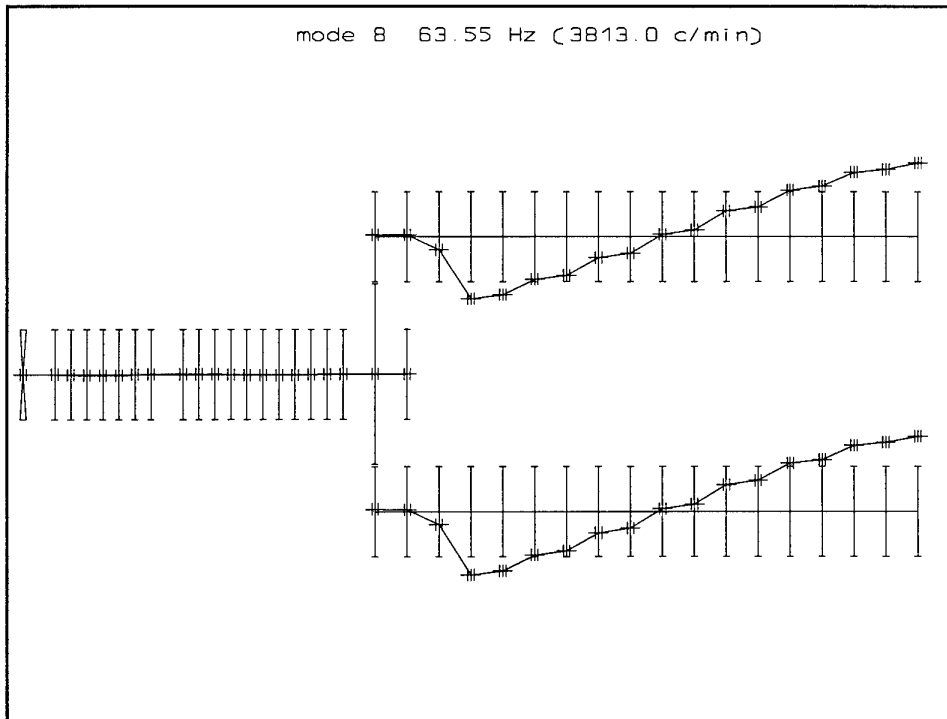

Figure 3.8 Mode 8

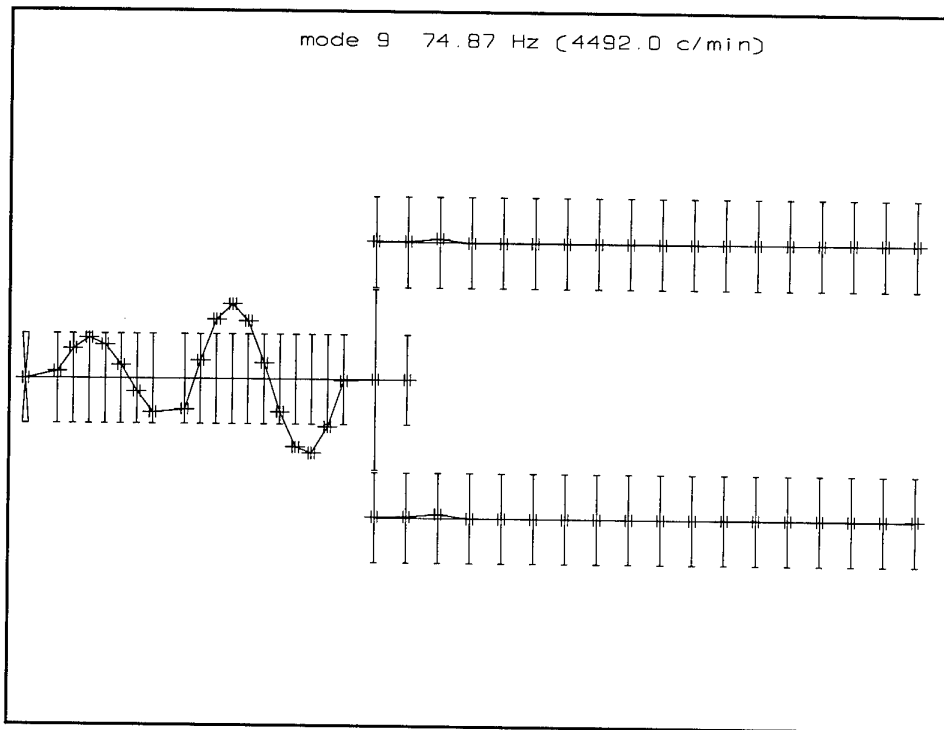

Figure 3.9 Mode 9

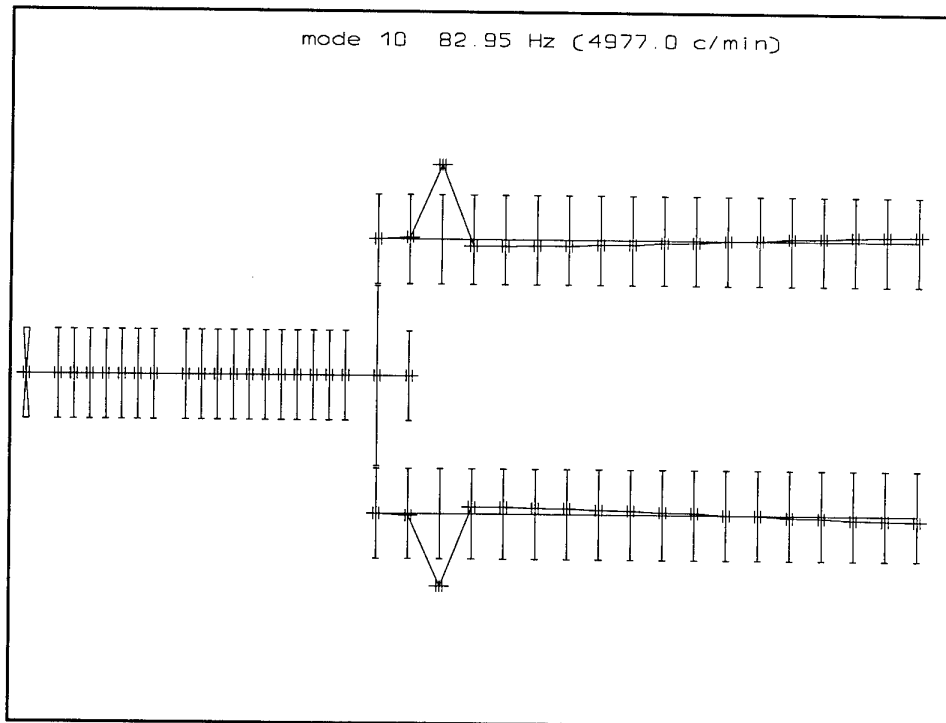

Figure 3.10 Mode 10

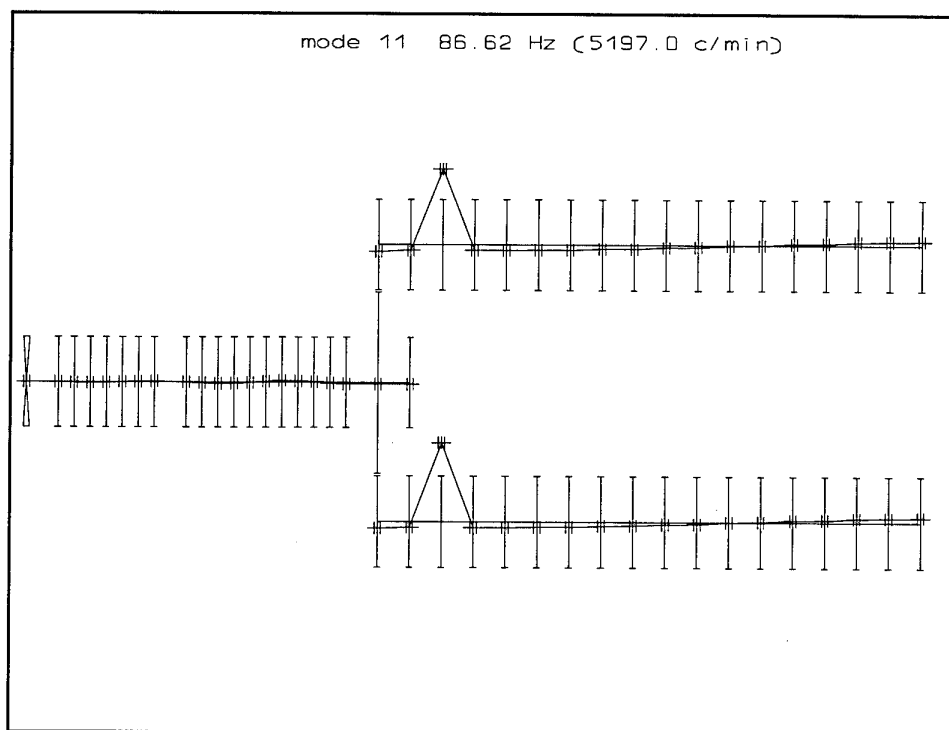

Figure 3.11 Mode 11

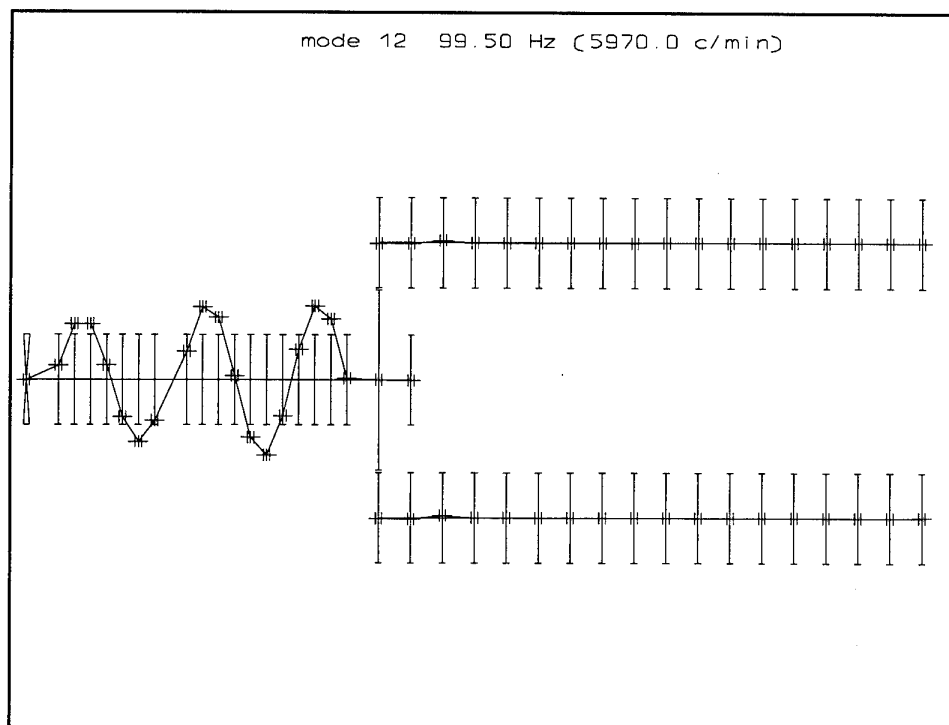

Figure 3.12 Mode 12

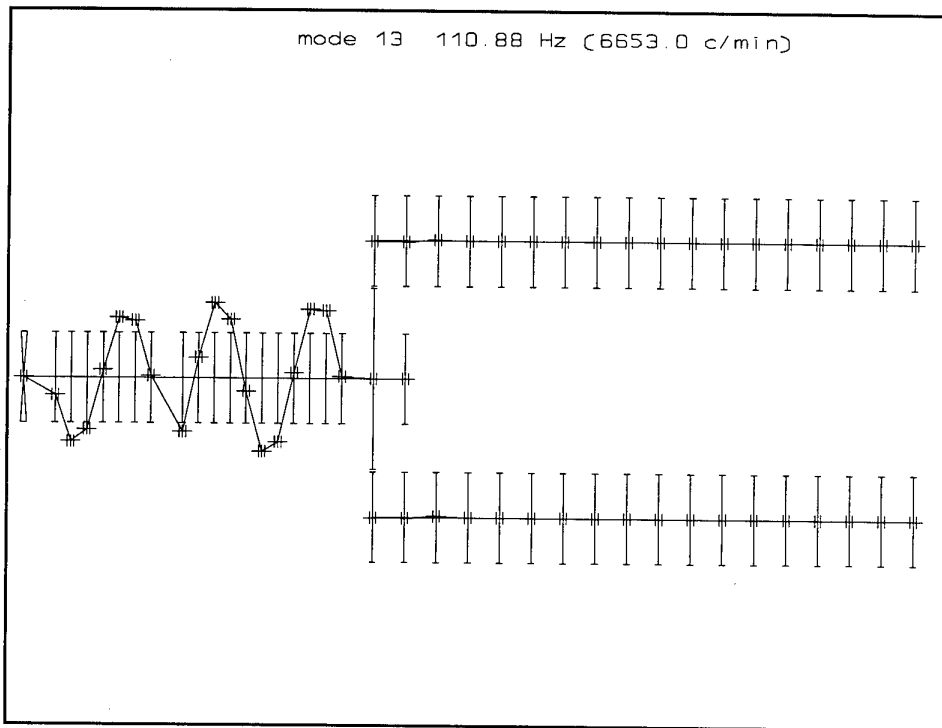

Figure 3.12 Mode 13

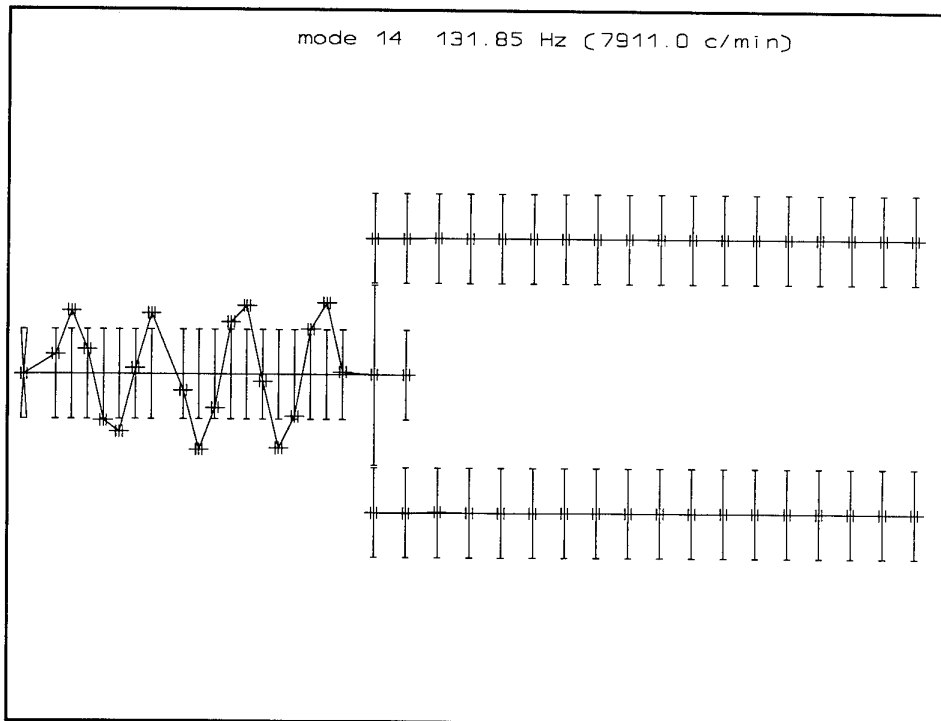

Figure 3.14 Mode 14

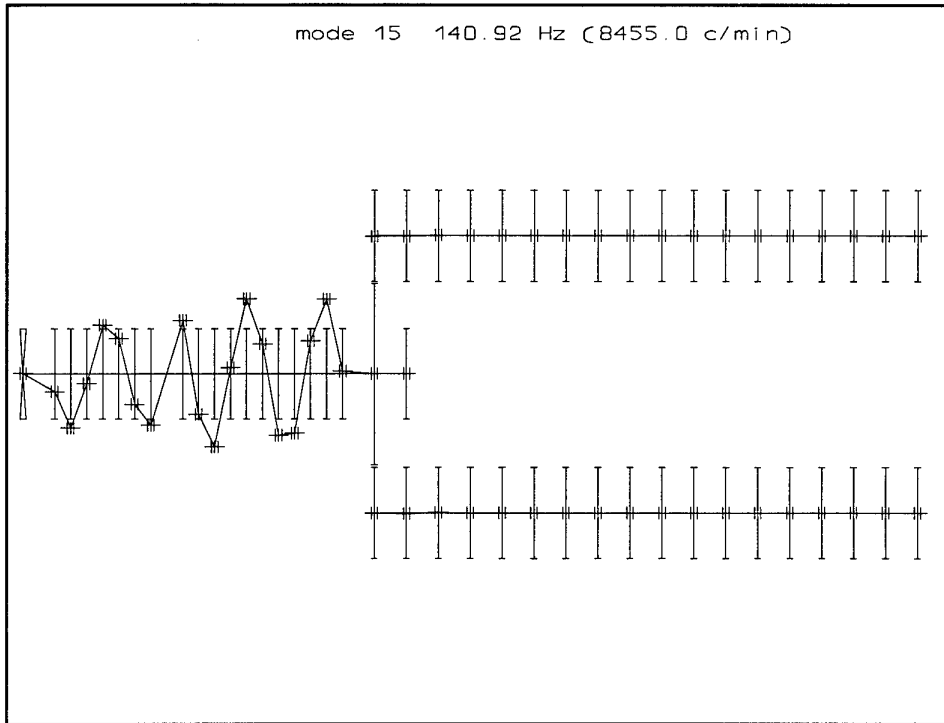

Figure 3.15 Mode 15

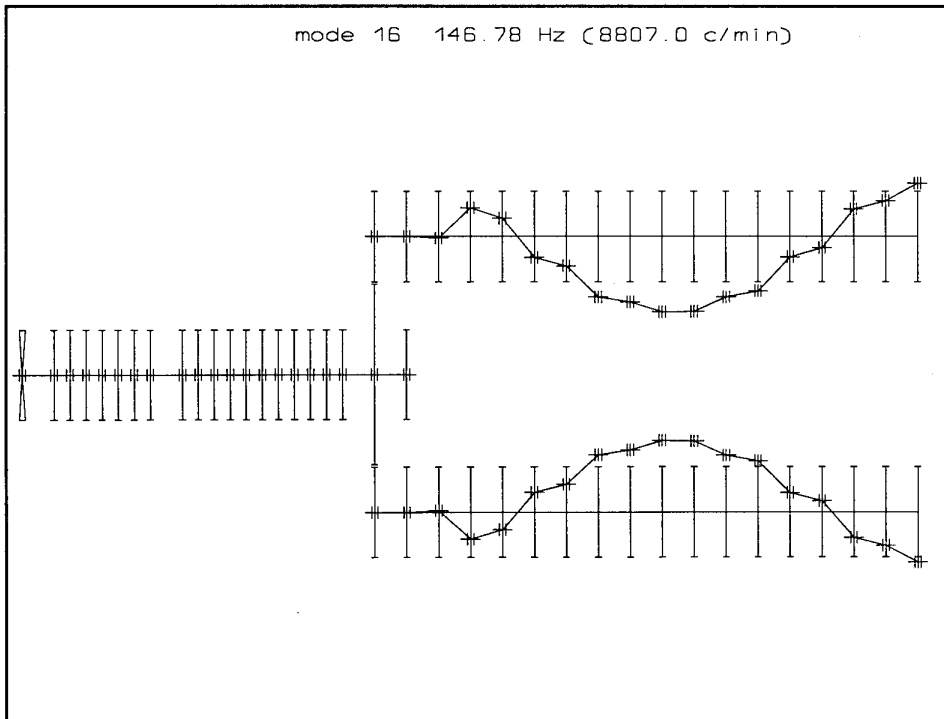

Figure 3.16 Mode 16

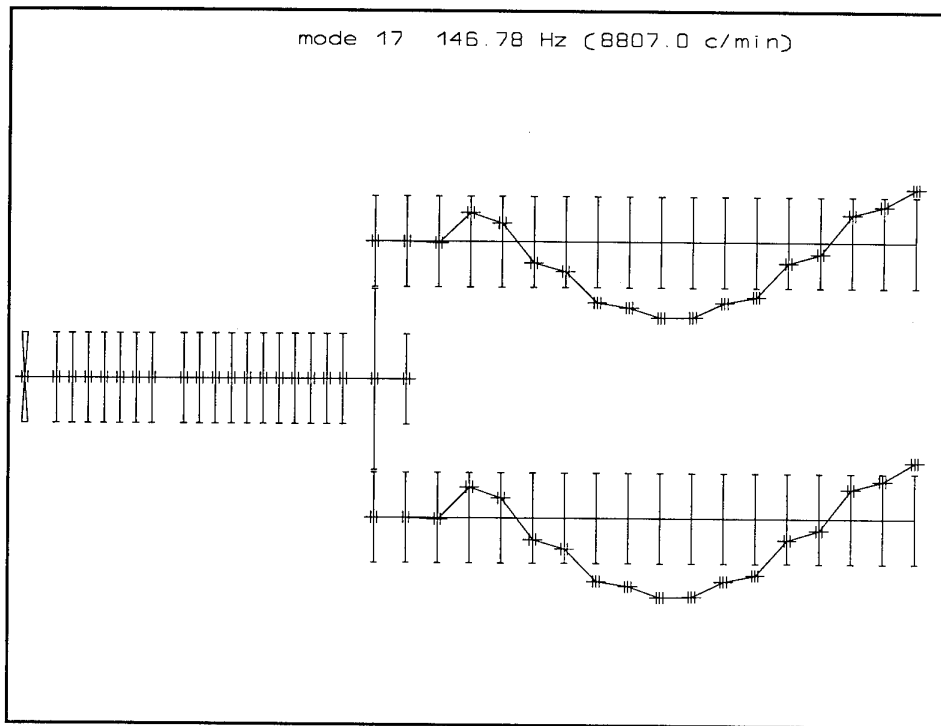

Figure 3.17 Mode 17

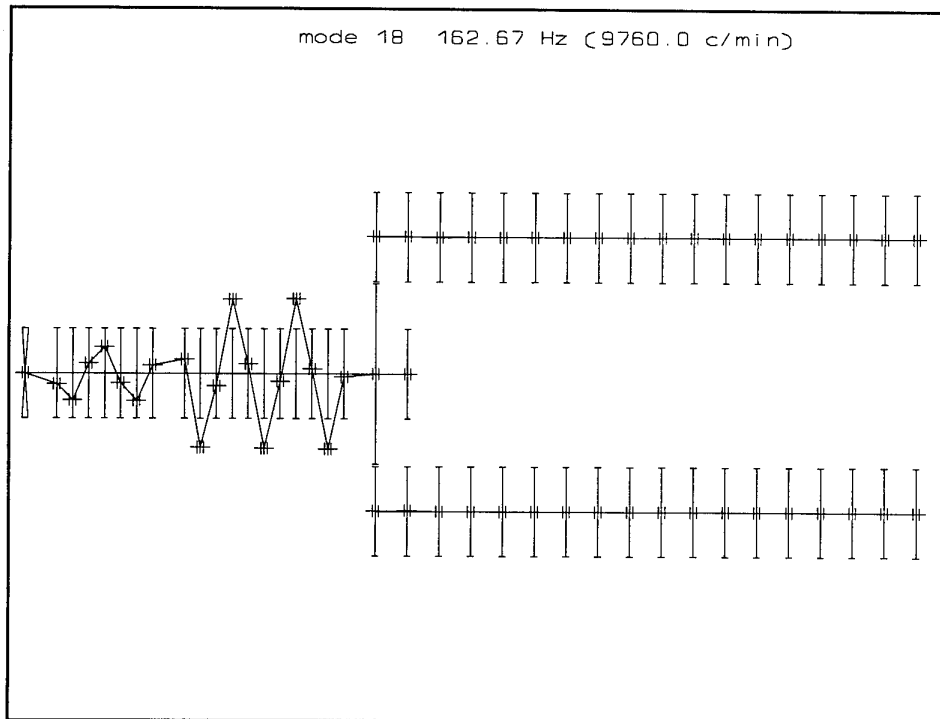

Figure 3.18 Mode 18

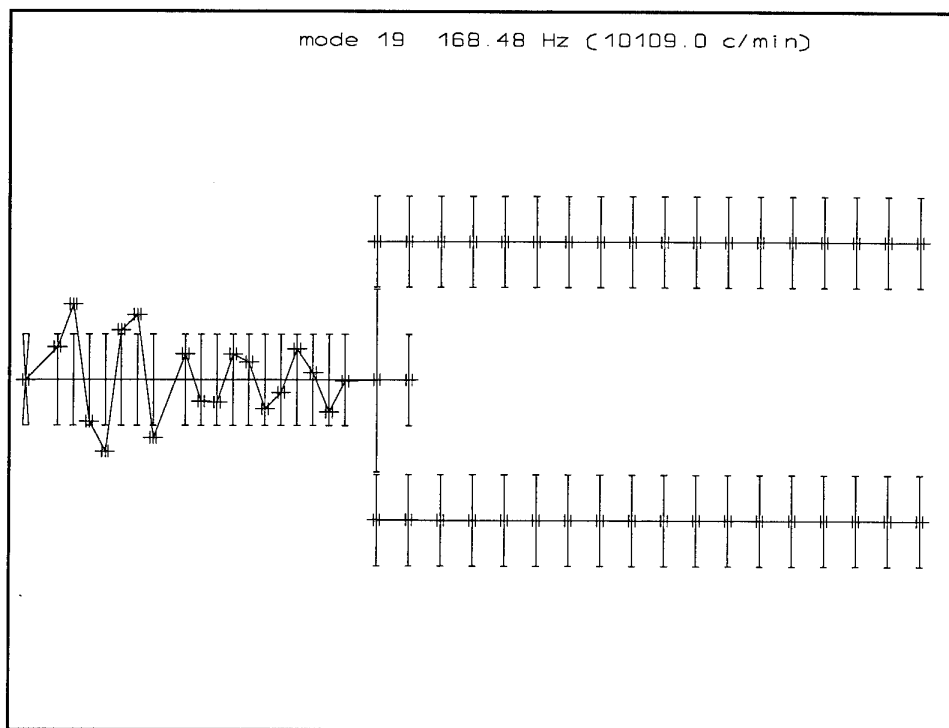

Figure 3.19 Mode 19

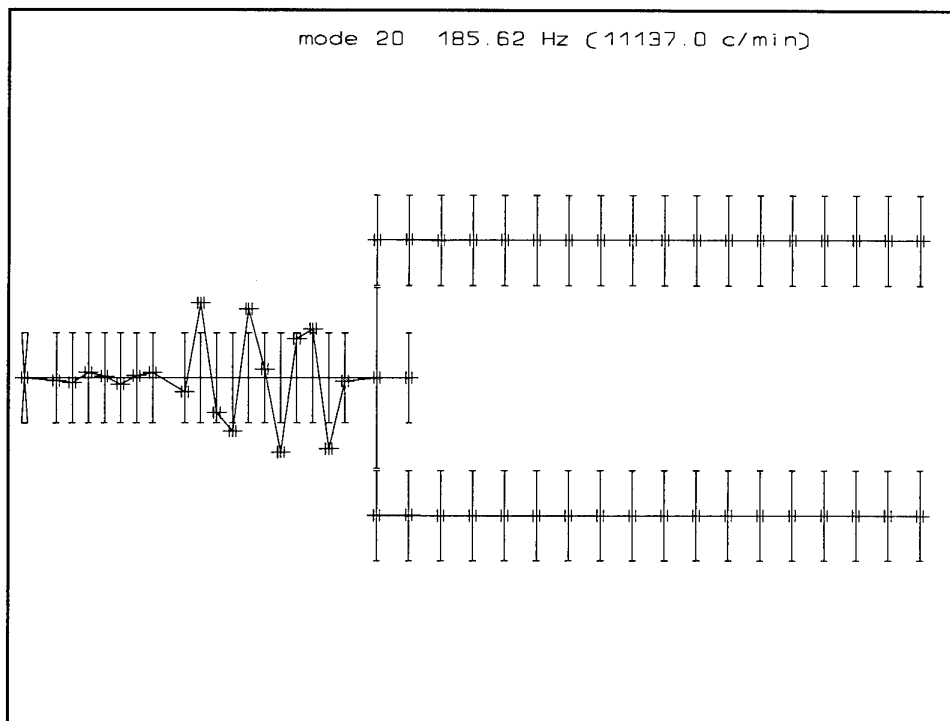

Figure 3.20 Mode 20

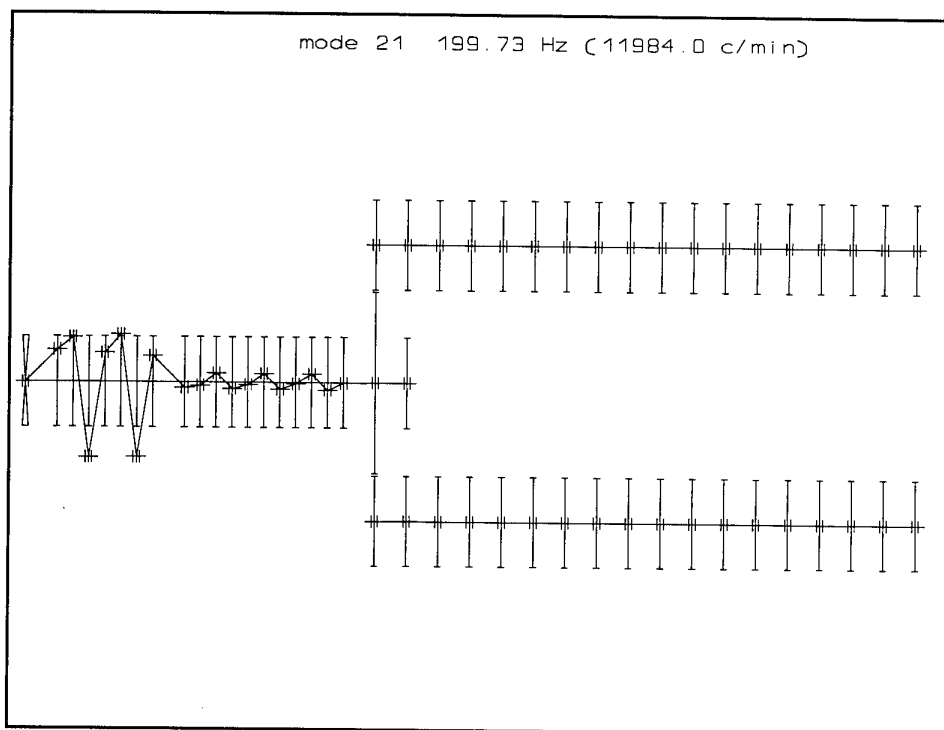

Figure 3.21 Mode 21

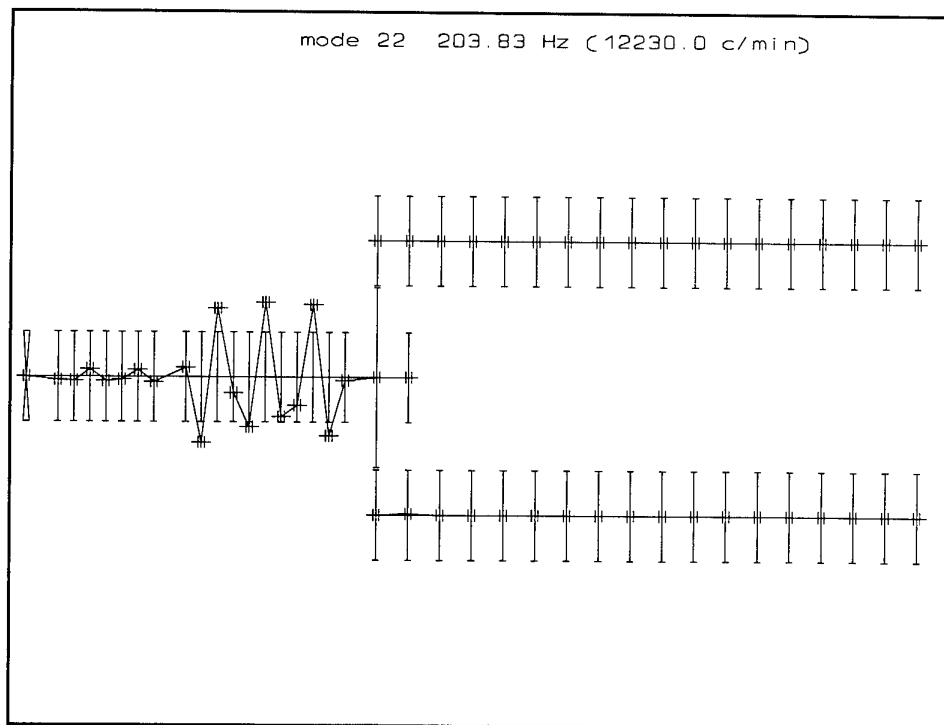

Figure 3.22 Mode 22

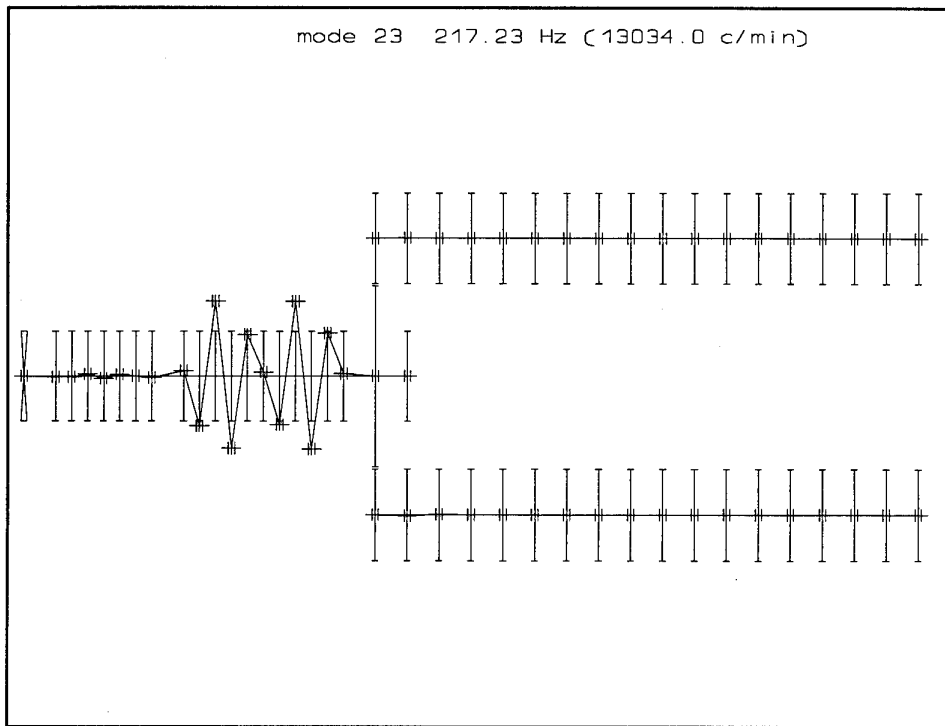

Figure 3.23 Mode 23

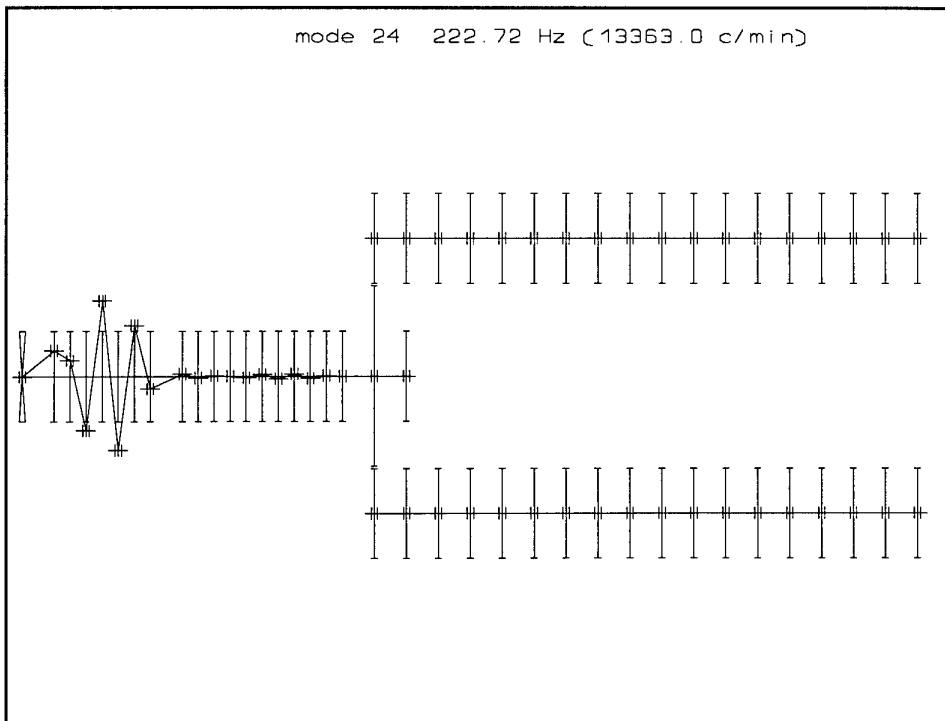

Figure 3.24 Mode 24

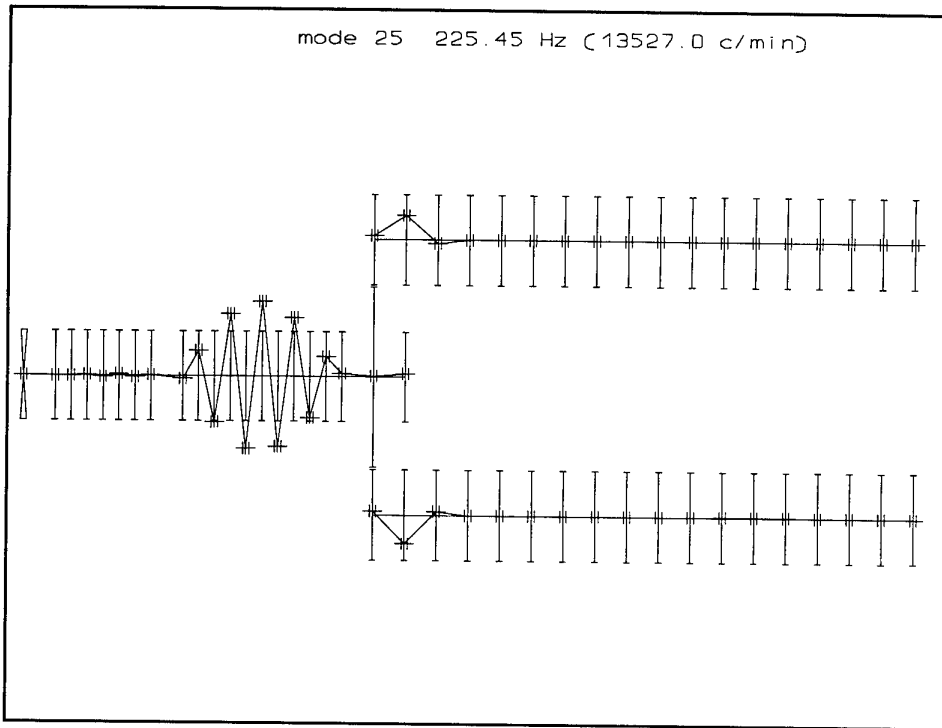

Figure 3.25 Mode 25

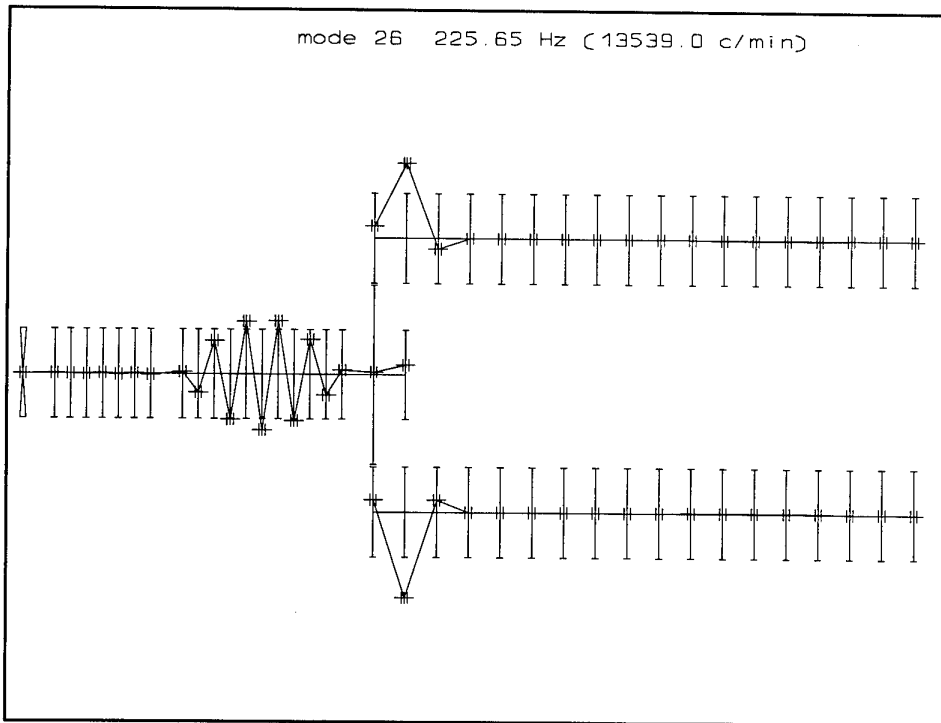

Figure 3.26 Mode 26

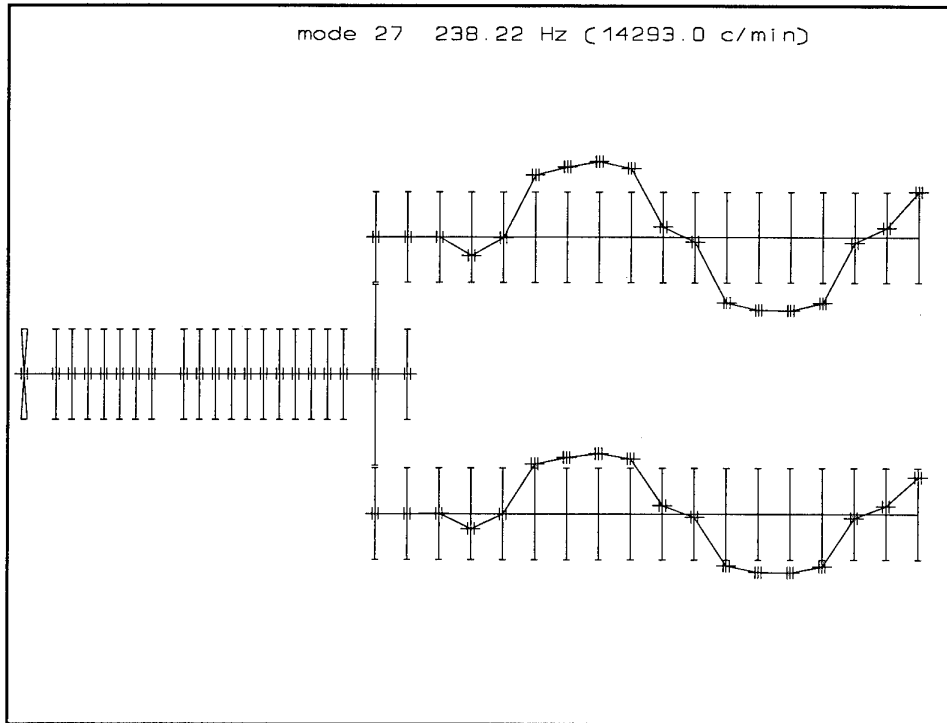

Figure 3.27 Mode 27

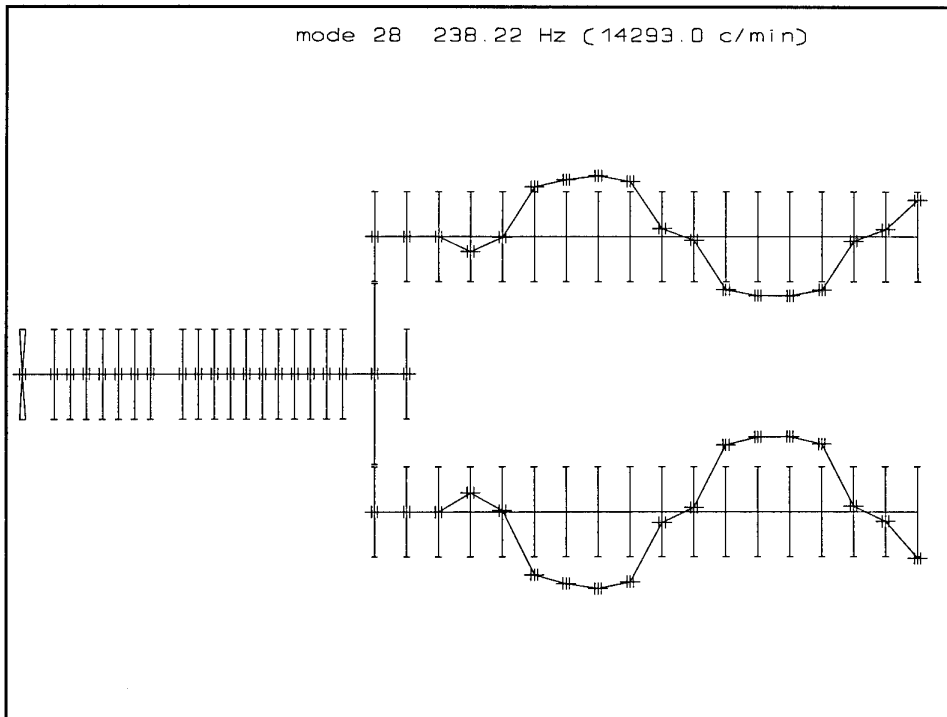

Figure 3.28 Mode 28

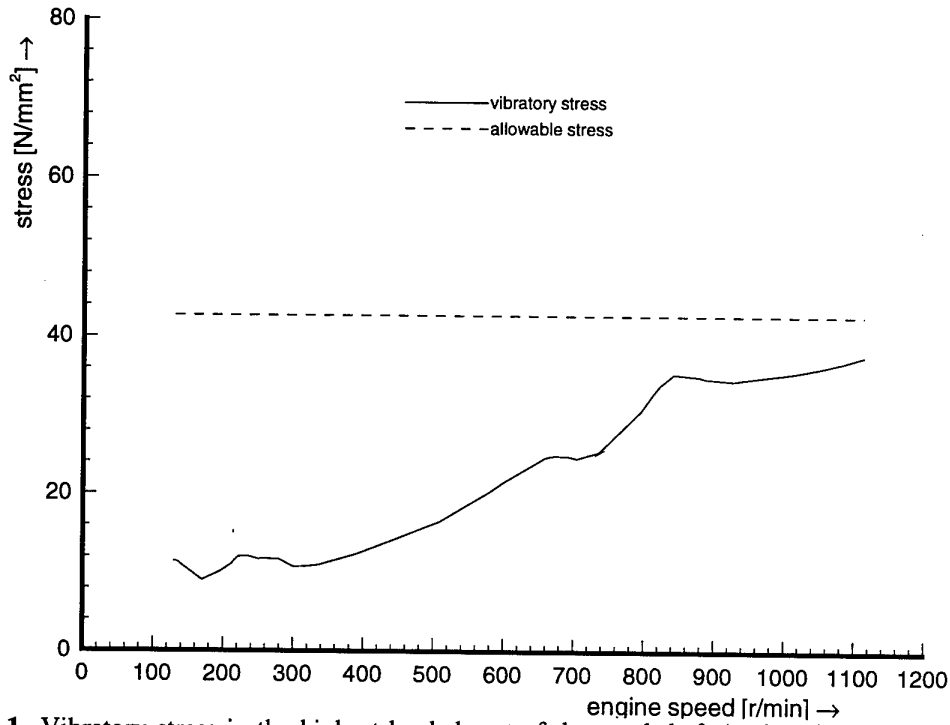

Figure 4.1 Vibratory stress in the highest loaded part of the crankshaft (spring 6), direct method

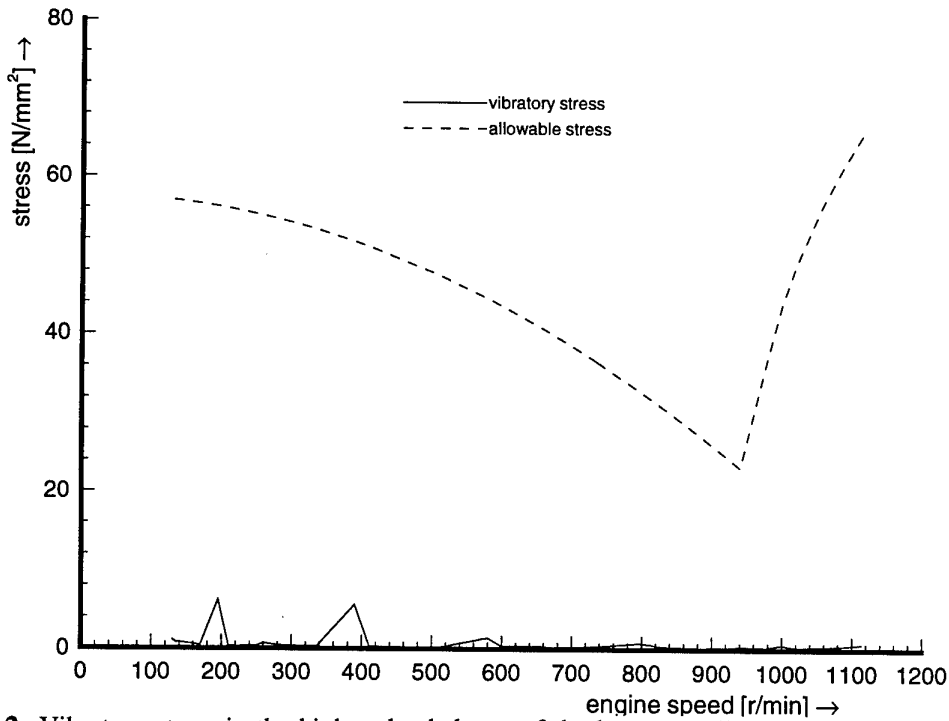

Figure 4.2 Vibratory stress in the highest loaded part of the long propeller shaft (spring 36), direct method

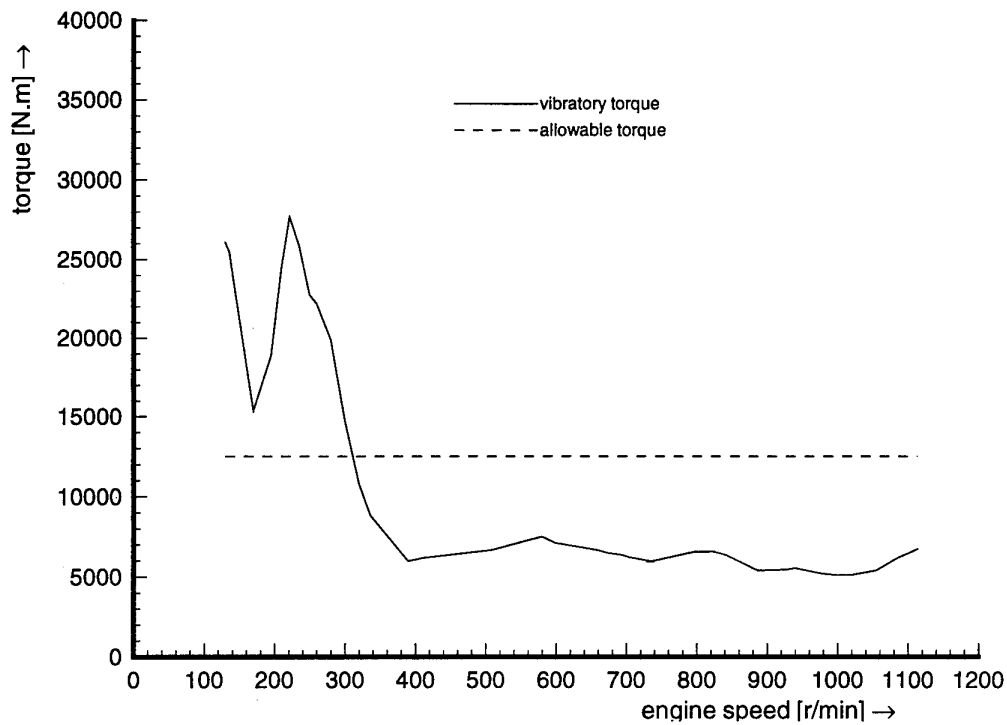

Figure 4.3 Vibratory torque in the flexible coupling (spring 15), direct method

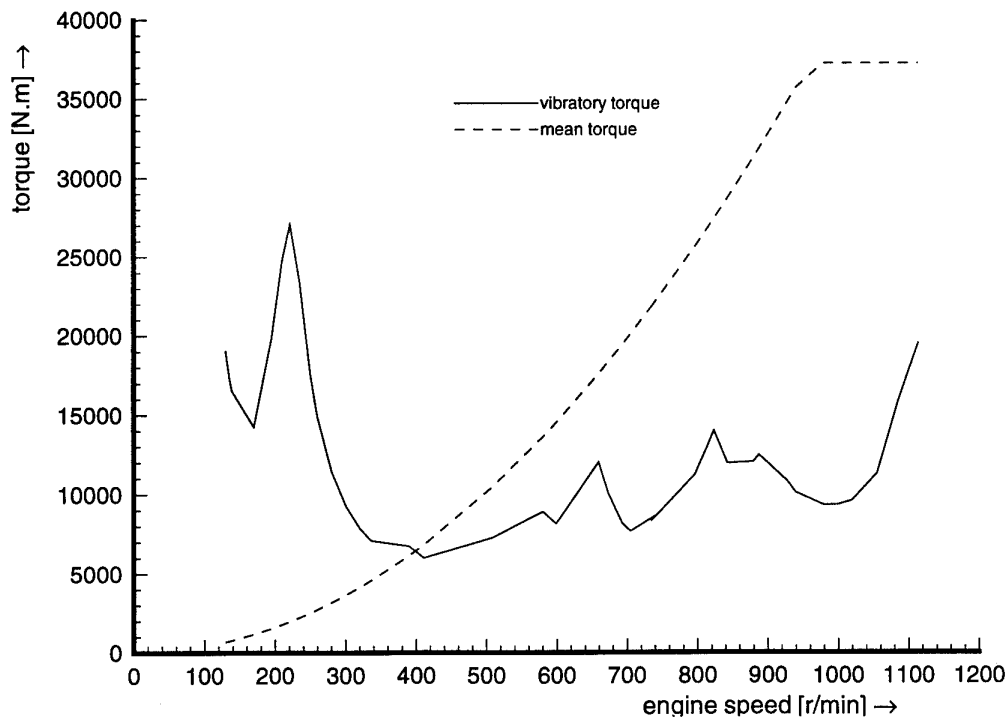

Figure 4.4 Vibratory and mean torque in the gear transmission, direct method

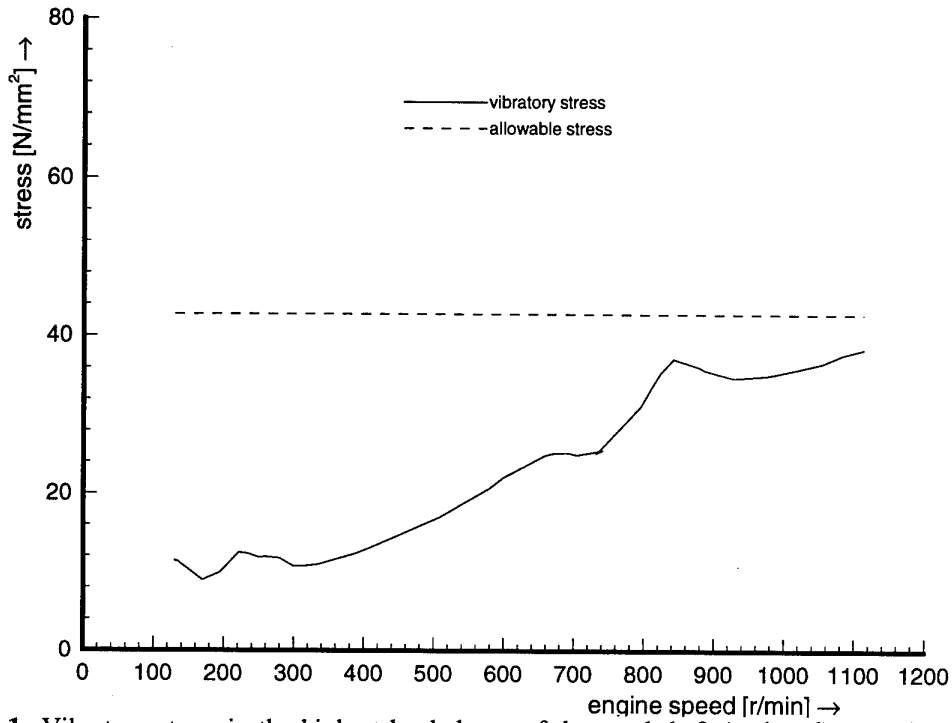

Figure 5.1 Vibratory stress in the highest loaded part of the crankshaft (spring 6), magnifier method

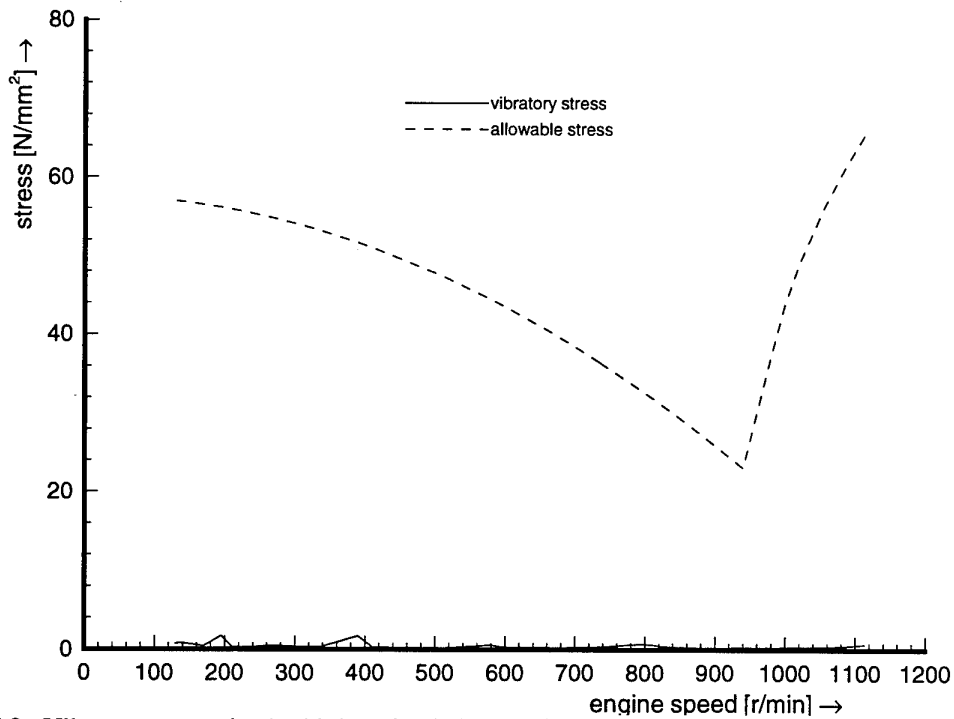

Figure 5.2 Vibratory stress in the highest loaded part of the long propeller shaft (spring 36), magnifier method

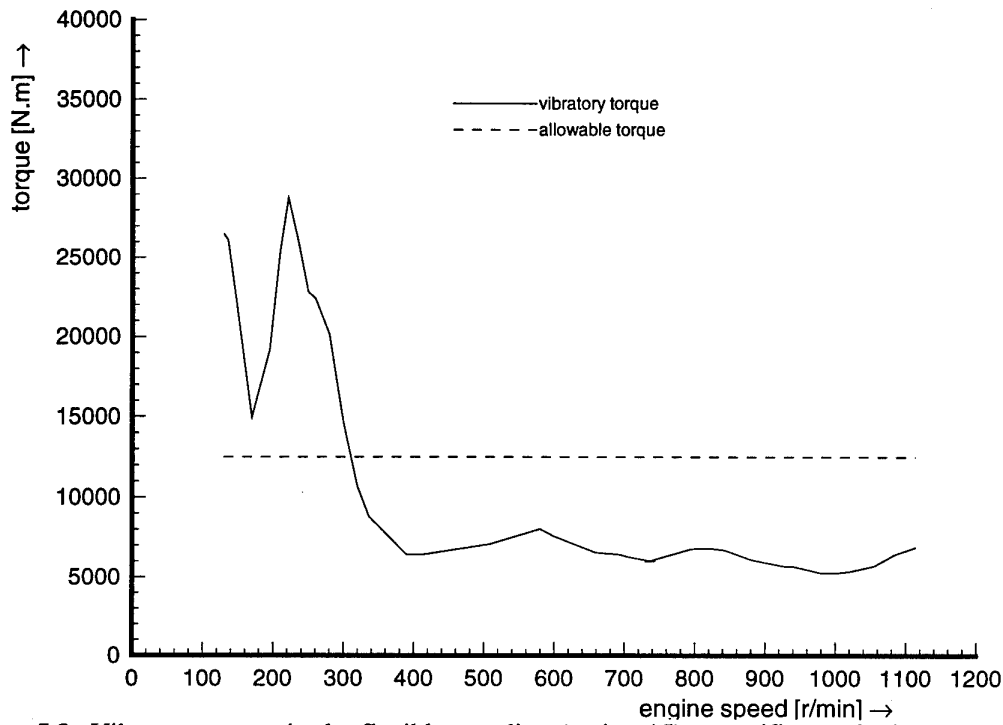

Figure 5.3 Vibratory torque in the flexible coupling (spring 15), magnifier method

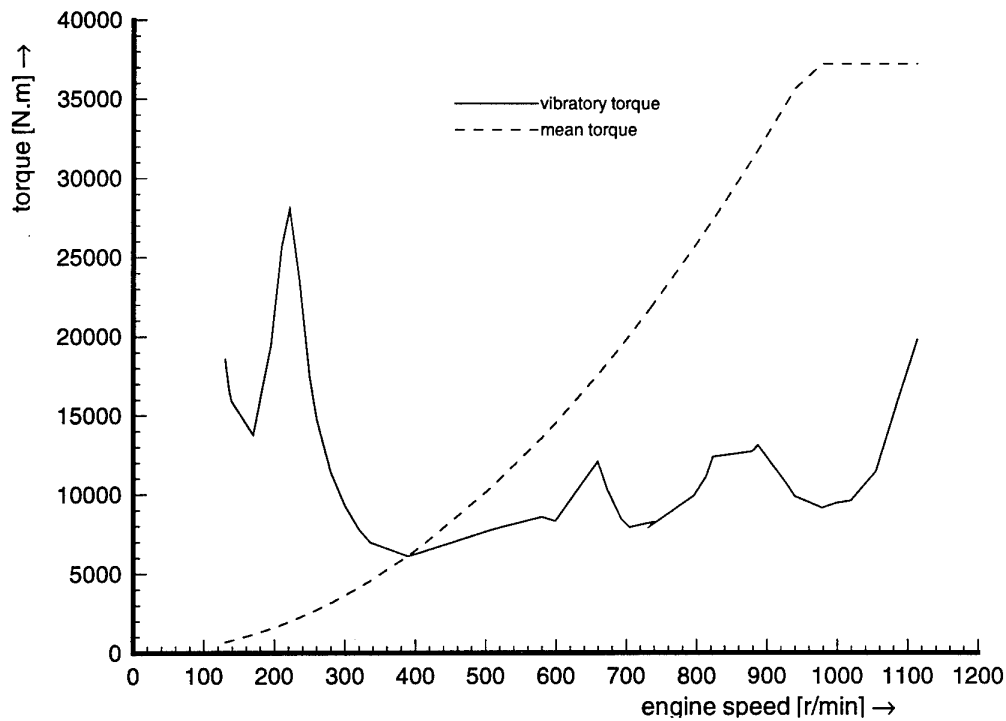

Figure 5.4 Vibratory and mean torque in the gear transmission, magnifier method

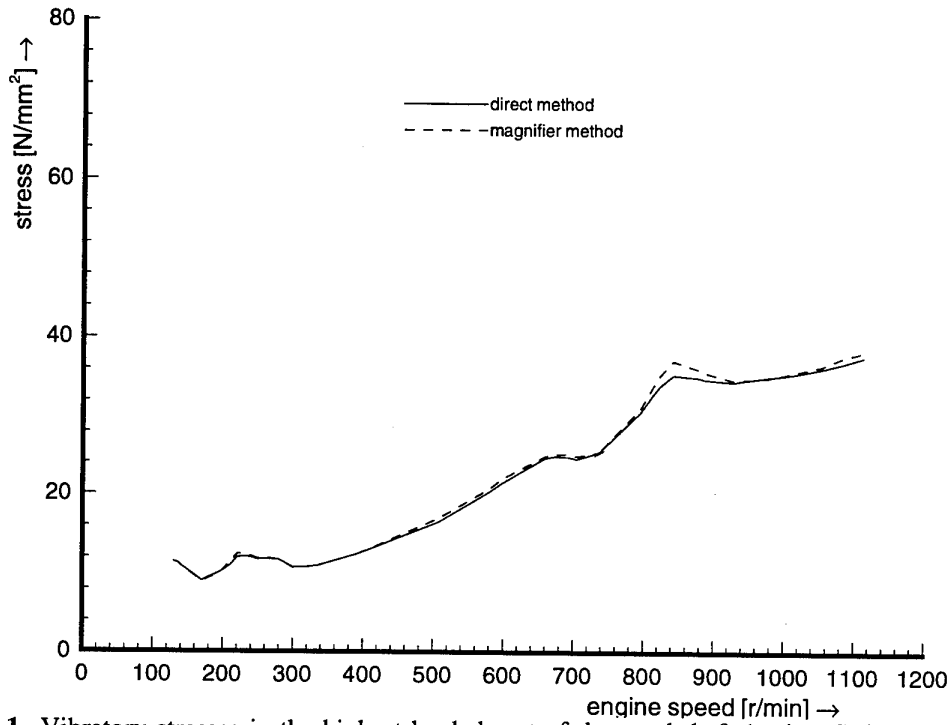

Figure 6.1 Vibratory stresses in the highest loaded part of the crankshaft (spring 6) from both types of analyses

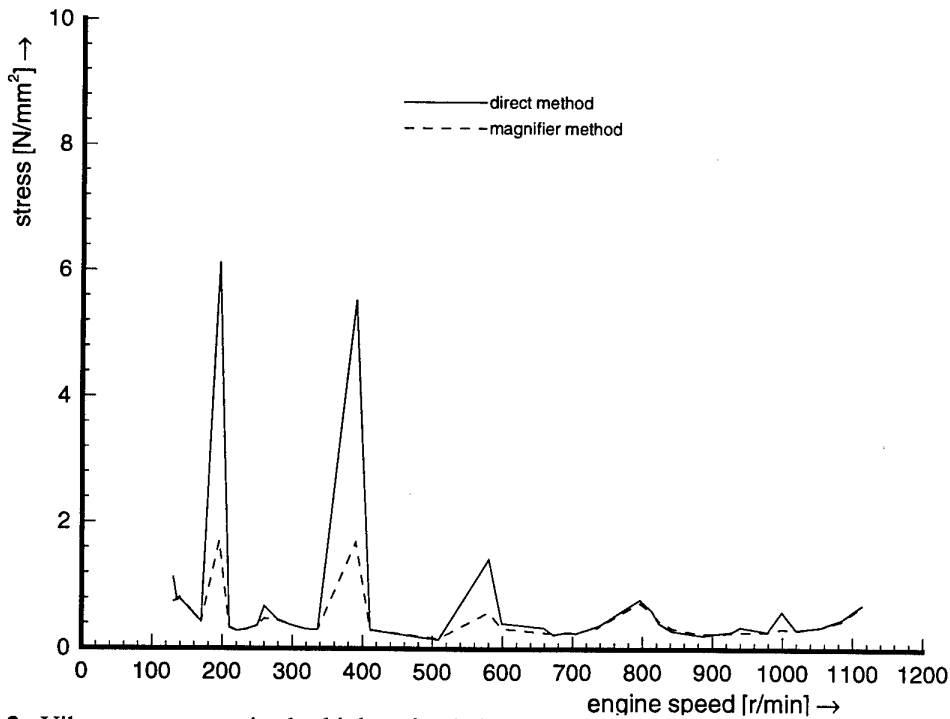

Figure 6.2 Vibratory stresses in the highest loaded part of the long propeller shaft (spring 36) from both types of analyses

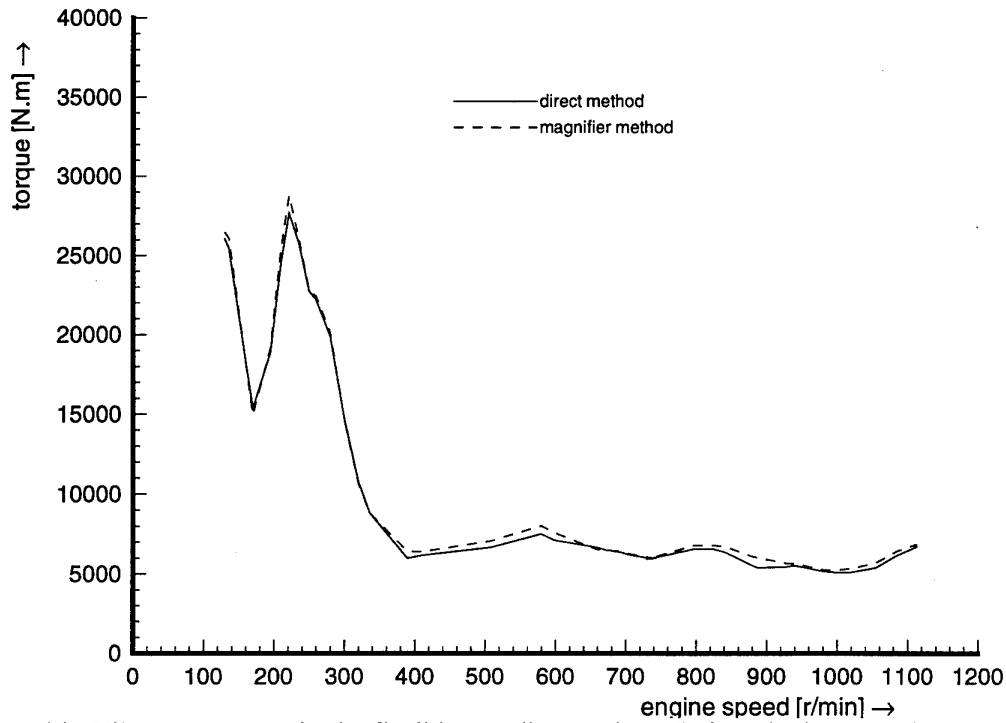

Figure 6.3 Vibratory torques in the flexible coupling (spring 15) from both types of analyses

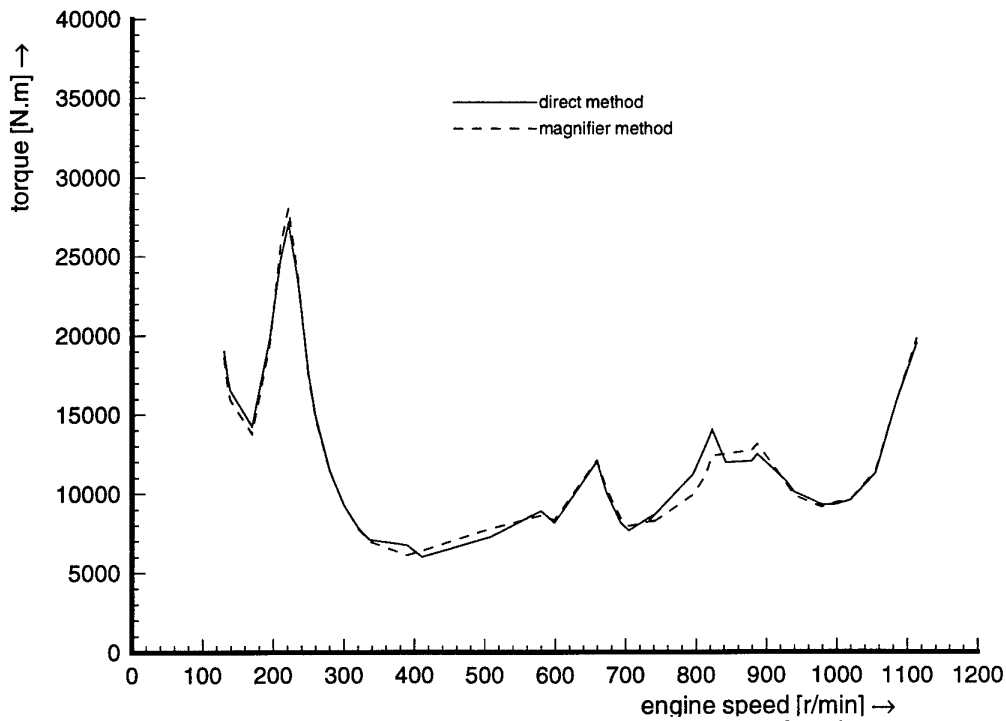

Figure 6.4 Vibratory torques in the gear transmission from both types of analyses

Appendix A: Critical engine speeds and vector summations

Critical engine speeds and vector summations

4-Stroke engine

Natural frequencies up to 15000. c/min

Critical engine speeds up to 30000. r/min

Vector summation results for relative amplitudes from free vibration tables
Natural frequency [c/min]

	Mode 1		Mode 2		Mode 3	
Nat.fr.-->	141.		664.		815.	
	Critical speed [r/min]	Vector summation	Critical speed [r/min]	Vector summation	Critical speed [r/min]	Vector summation
Order .5	281.	4.21E-03	1329.	9.27E-02	1630.	1.38E-01
Order 1.0	141.	1.00E-03	664.	2.18E-02	815.	3.23E-02
Order 1.5	94.	8.89E-03	443.	1.96E-01	543.	2.93E-01
Order 2.0	70.	7.13E-04	332.	1.54E-02	407.	2.29E-02
Order 2.5	56.	1.99E-03	266.	4.38E-02	326.	6.55E-02
Order 3.0	47.	3.10E+00	221.	3.01E+00	272.	2.96E+00
Order 3.5	40.	2.00E-04	190.	4.40E-03	233.	6.57E-03
Order 4.0	35.	1.92E-04	166.	4.17E-03	204.	6.19E-03
Order 4.5	31.	4.28E-03	148.	9.46E-02	181.	1.41E-01
Order 5.0	28.	6.38E-04	133.	1.38E-02	163.	2.04E-02
Order 5.5	26.	3.17E-03	121.	7.00E-02	148.	1.05E-01
Order 6.0	23.	1.04E+01	111.	1.01E+01	136.	9.91E+00
Order 6.5	22.	4.12E-03	102.	9.05E-02	125.	1.35E-01
Order 7.0	20.	1.10E-03	95.	2.39E-02	116.	3.55E-02
Order 7.5	19.	1.11E-02	89.	2.45E-01	109.	3.66E-01
Order 8.0	18.	1.05E-03	83.	2.26E-02	102.	3.35E-02
Order 8.5	17.	3.62E-03	78.	8.00E-02	96.	1.20E-01
Order 9.0	16.	8.47E+00	74.	8.22E+00	91.	8.09E+00
Order 9.5	15.	2.32E-03	70.	5.10E-02	86.	7.62E-02
Order 10.0	14.	3.74E-04	66.	8.22E-03	81.	1.22E-02
Order 10.5	13.	1.48E-03	63.	3.25E-02	78.	4.85E-02
Order 11.0	13.	9.91E-05	60.	2.10E-03	74.	3.11E-03
Order 11.5	12.	1.30E-03	58.	2.86E-02	71.	4.27E-02
Order 12.0	12.	5.99E+00	55.	5.81E+00	68.	5.72E+00

		Mode 4		Mode 5		Mode 6	
Nat.fr.-->		1171.		2338.		3636.	
		Critical speed [r/min]	Vector summation	Critical speed [r/min]	Vector summation	Critical speed [r/min]	Vector summation
Order .5		2341.	2.79E-01	4677.	9.89E-01	7271.	1.97E+00
Order 1.0		1171.	6.35E-02	2338.	1.87E-01	3636.	1.97E-01
Order 1.5		780.	5.92E-01	1559.	2.12E+00	2424.	4.34E+00
Order 2.0		585.	4.50E-02	1169.	1.33E-01	1818.	1.41E-01
Order 2.5		468.	1.32E-01	935.	4.68E-01	1454.	9.31E-01
Order 3.0		390.	2.81E+00	779.	2.04E+00	1212.	9.07E-01
Order 3.5		334.	1.32E-02	668.	4.60E-02	1039.	8.89E-02
Order 4.0		293.	1.22E-02	585.	3.61E-02	909.	4.34E-02
Order 4.5		260.	2.86E-01	520.	1.03E+00	808.	2.09E+00
Order 5.0		234.	4.02E-02	468.	1.19E-01	727.	1.26E-01
Order 5.5		213.	2.11E-01	425.	7.47E-01	661.	1.49E+00
Order 6.0		195.	9.41E+00	390.	6.81E+00	606.	2.85E+00
Order 6.5		180.	2.73E-01	360.	9.66E-01	559.	1.92E+00
Order 7.0		167.	6.98E-02	334.	2.06E-01	519.	2.16E-01
Order 7.5		156.	7.40E-01	312.	2.66E+00	485.	5.42E+00
Order 8.0		146.	6.58E-02	292.	1.94E-01	454.	2.04E-01
Order 8.5		138.	2.41E-01	275.	8.55E-01	428.	1.70E+00
Order 9.0		130.	7.68E+00	260.	5.56E+00	404.	2.33E+00
Order 9.5		123.	1.54E-01	246.	5.45E-01	383.	1.08E+00
Order 10.0		117.	2.40E-02	234.	7.08E-02	364.	7.70E-02
Order 10.5		111.	9.81E-02	223.	3.51E-01	346.	7.14E-01
Order 11.0		106.	6.11E-03	213.	1.85E-02	331.	2.88E-02
Order 11.5		102.	8.61E-02	203.	3.05E-01	316.	6.07E-01
Order 12.0		98.	5.43E+00	195.	3.94E+00	303.	1.67E+00

		Mode 7		Mode 8		Mode 9	
Nat. fr.-->		3805.		3813.		4492.	
		Critical speed [r/min]	Vector summation	Critical speed [r/min]	Vector summation	Critical speed [r/min]	Vector summation
Order .5		7609.	2.09E+00	7626.	2.10E+00	8984.	2.56E+00
Order 1.0		3805.	1.75E-01	3813.	1.73E-01	4492.	1.89E-02
Order 1.5		2536.	4.63E+00	2542.	4.65E+00	2995.	5.77E+00
Order 2.0		1902.	1.25E-01	1906.	1.24E-01	2246.	3.40E-02
Order 2.5		1522.	9.90E-01	1525.	9.93E-01	1797.	4.21E+00
Order 3.0		1268.	7.61E-01	1271.	7.54E-01	1497.	1.09E-01
Order 3.5		1087.	9.42E-02	1089.	9.45E-02	1283.	1.14E-01
Order 4.0		951.	4.18E-02	953.	4.17E-02	1123.	4.37E-02
Order 4.5		845.	2.23E+00	847.	2.24E+00	998.	2.78E+00
Order 5.0		761.	1.12E-01	763.	1.11E-01	898.	3.64E-02
Order 5.5		692.	1.58E+00	693.	1.59E+00	817.	1.93E+00
Order 6.0		634.	2.29E+00	635.	2.26E+00	749.	2.13E-01
Order 6.5		585.	2.05E+00	587.	2.05E+00	691.	2.50E+00
Order 7.0		544.	1.92E-01	545.	1.90E-01	642.	4.58E-03
Order 7.5		507.	5.79E+00	508.	5.81E+00	599.	7.21E+00
Order 8.0		476.	1.81E-01	477.	1.80E-01	562.	1.53E-02
Order 8.5		448.	1.81E+00	449.	1.81E+00	528.	2.21E+00
Order 9.0		423.	1.88E+00	424.	1.86E+00	499.	3.00E-01
Order 9.5		400.	1.15E+00	401.	1.16E+00	473.	1.41E+00
Order 10.0		380.	7.00E-02	381.	6.96E-02	449.	4.17E-02
Order 10.5		362.	7.63E-01	363.	7.65E-01	428.	9.50E-01
Order 11.0		346.	3.04E-02	347.	3.05E-02	408.	4.42E-02
Order 11.5		331.	6.45E-01	332.	6.47E-01	391.	7.88E-01
Order 12.0		317.	1.35E+00	318.	1.34E+00	374.	3.67E-01

		Mode 10		Mode 11		Mode 12	
Nat. fr.-->		4977.		5197.		5970.	
		Critical speed [r/min]	Vector summation	Critical speed [r/min]	Vector summation	Critical speed [r/min]	Vector summation
Order	.5	9954.	2.83E+00	10394.	2.93E+00	11939.	3.17E+00
Order	1.0	4977.	2.27E-01	5197.	3.60E-01	5970.	1.00E+00
Order	1.5	3318.	6.49E+00	3465.	6.78E+00	3980.	7.56E+00
Order	2.0	2489.	1.67E-01	2599.	2.60E-01	2985.	7.16E-01
Order	2.5	1991.	1.34E+00	2079.	1.39E+00	2388.	1.50E+00
Order	3.0	1659.	6.63E-01	1732.	8.41E-01	1990.	1.50E+00
Order	3.5	1422.	1.27E-01	1485.	1.33E-01	1706.	1.53E-01
Order	4.0	1244.	7.43E-02	1299.	9.74E-02	1492.	2.18E-01
Order	4.5	1106.	3.13E+00	1155.	3.27E+00	1327.	3.65E+00
Order	5.0	995.	1.51E-01	1039.	2.34E-01	1194.	6.40E-01
Order	5.5	905.	2.14E+00	945.	2.22E+00	1085.	2.39E+00
Order	6.0	830.	1.65E+00	866.	2.36E+00	995.	4.74E+00
Order	6.5	766.	2.77E+00	800.	2.87E+00	918.	3.10E+00
Order	7.0	711.	2.48E-01	742.	3.94E-01	853.	1.10E+00
Order	7.5	664.	8.11E+00	693.	8.47E+00	796.	9.44E+00
Order	8.0	622.	2.35E-01	650.	3.73E-01	746.	1.04E+00
Order	8.5	586.	2.45E+00	611.	2.53E+00	702.	2.74E+00
Order	9.0	553.	1.37E+00	577.	1.95E+00	663.	3.88E+00
Order	9.5	524.	1.56E+00	547.	1.61E+00	628.	1.74E+00
Order	10.0	498.	1.03E-01	520.	1.50E-01	597.	3.91E-01
Order	10.5	474.	1.07E+00	495.	1.12E+00	569.	1.26E+00
Order	11.0	452.	6.49E-02	472.	7.78E-02	543.	1.41E-01
Order	11.5	433.	8.72E-01	452.	9.04E-01	519.	9.78E-01
Order	12.0	415.	1.03E+00	433.	1.42E+00	497.	2.77E+00

		Mode 13		Mode 14		Mode 15	
Nat. fr.-->		6653.		7911.		8455.	
		Critical speed [r/min]	Vector summation	Critical speed [r/min]	Vector summation	Critical speed [r/min]	Vector summation
Order .5	13307.		3.19E+00	15823.	2.69E+00	16910.	2.25E+00
Order 1.0	6653.		1.83E+00	7911.	4.04E+00	8455.	5.27E+00
Order 1.5	4436.		7.86E+00	5274.	7.15E+00	5637.	6.24E+00
Order 2.0	3327.		1.30E+00	3956.	2.87E+00	4227.	3.74E+00
Order 2.5	2661.		1.51E+00	3165.	1.28E+00	3382.	1.09E+00
Order 3.0	2218.		2.03E+00	2637.	2.73E+00	2818.	2.91E+00
Order 3.5	1901.		1.75E-01	2260.	2.37E-01	2416.	2.73E-01
Order 4.0	1663.		3.75E-01	1978.	7.92E-01	2114.	1.02E+00
Order 4.5	1479.		3.80E+00	1758.	3.50E+00	1879.	3.10E+00
Order 5.0	1331.		1.16E+00	1582.	2.56E+00	1691.	3.34E+00
Order 5.5	1210.		2.41E+00	1438.	2.03E+00	1537.	1.71E+00
Order 6.0	1109.		6.58E+00	1319.	9.06E+00	1409.	9.67E+00
Order 6.5	1024.		3.11E+00	1217.	2.62E+00	1301.	2.20E+00
Order 7.0	950.		2.01E+00	1130.	4.44E+00	1208.	5.79E+00
Order 7.5	887.		9.82E+00	1055.	8.92E+00	1127.	7.77E+00
Order 8.0	832.		1.90E+00	989.	4.19E+00	1057.	5.46E+00
Order 8.5	783.		2.75E+00	931.	2.32E+00	995.	1.95E+00
Order 9.0	739.		5.38E+00	879.	7.40E+00	939.	7.90E+00
Order 9.5	700.		1.76E+00	833.	1.49E+00	890.	1.26E+00
Order 10.0	665.		7.02E-01	791.	1.53E+00	845.	2.00E+00
Order 10.5	634.		1.33E+00	753.	1.35E+00	805.	1.34E+00
Order 11.0	605.		2.21E-01	719.	4.26E-01	769.	5.36E-01
Order 11.5	579.		9.87E-01	688.	8.50E-01	735.	7.34E-01
Order 12.0	554.		3.82E+00	659.	5.24E+00	705.	5.59E+00

		Mode 16		Mode 17		Mode 18	
Nat.fr.-->		8807.		8807.		9760.	
		Critical speed [r/min]	Vector summation	Critical speed [r/min]	Vector summation	Critical speed [r/min]	Vector summation
Order .5		17613.	1.90E+00	17613.	1.90E+00	19521.	7.26E-01
Order 1.0		8807.	6.15E+00	8807.	6.15E+00	9760.	8.83E+00
Order 1.5		5871.	5.43E+00	5871.	5.43E+00	6507.	2.38E+00
Order 2.0		4403.	4.36E+00	4403.	4.36E+00	4880.	6.26E+00
Order 2.5		3523.	9.34E-01	3523.	9.34E-01	3904.	4.73E-01
Order 3.0		2936.	2.97E+00	2936.	2.97E+00	3253.	2.95E+00
Order 3.5		2516.	2.99E-01	2516.	2.99E-01	2789.	3.71E-01
Order 4.0		2202.	1.19E+00	2202.	1.19E+00	2440.	1.69E+00
Order 4.5		1957.	2.76E+00	1957.	2.76E+00	2169.	1.68E+00
Order 5.0		1761.	3.89E+00	1761.	3.89E+00	1952.	5.59E+00
Order 5.5		1601.	1.45E+00	1601.	1.45E+00	1775.	5.99E-01
Order 6.0		1468.	9.91E+00	1468.	9.91E+00	1627.	9.87E+00
Order 6.5		1355.	1.86E+00	1355.	1.86E+00	1502.	7.13E-01
Order 7.0		1258.	6.76E+00	1258.	6.76E+00	1394.	9.71E+00
Order 7.5		1174.	6.75E+00	1174.	6.75E+00	1301.	2.79E+00
Order 8.0		1101.	6.38E+00	1101.	6.38E+00	1220.	9.16E+00
Order 8.5		1036.	1.65E+00	1036.	1.65E+00	1148.	6.54E-01
Order 9.0		979.	8.09E+00	979.	8.09E+00	1084.	8.06E+00
Order 9.5		927.	1.07E+00	927.	1.07E+00	1027.	5.05E-01
Order 10.0		881.	2.33E+00	881.	2.33E+00	976.	3.33E+00
Order 10.5		839.	1.33E+00	839.	1.33E+00	930.	1.44E+00
Order 11.0		801.	6.14E-01	801.	6.14E-01	887.	8.53E-01
Order 11.5		766.	6.46E-01	766.	6.46E-01	849.	4.17E-01
Order 12.0		734.	5.72E+00	734.	5.72E+00	813.	5.70E+00

		Mode 19		Mode 20		Mode 21	
Nat.fr.-->		10109.		11137.		11984.	
		Critical speed [r/min]	Vector summation	Critical speed [r/min]	Vector summation	Critical speed [r/min]	Vector summation
Order	.5	20218.	2.32E-01	22274.	1.47E+00	23969.	3.13E+00
Order	1.0	10109.	9.90E+00	11137.	1.32E+01	11984.	1.60E+01
Order	1.5	6739.	1.17E+00	7425.	5.29E+00	7990.	1.18E+01
Order	2.0	5055.	7.02E+00	5568.	9.37E+00	5992.	1.13E+01
Order	2.5	4044.	3.67E-01	4455.	8.07E-01	4794.	1.55E+00
Order	3.0	3370.	2.87E+00	3712.	2.44E+00	3995.	1.88E+00
Order	3.5	2888.	3.97E-01	3182.	4.70E-01	3424.	5.31E-01
Order	4.0	2527.	1.90E+00	2784.	2.54E+00	2996.	3.14E+00
Order	4.5	2246.	1.48E+00	2475.	3.10E+00	2663.	6.03E+00
Order	5.0	2022.	6.26E+00	2227.	8.36E+00	2397.	1.01E+01
Order	5.5	1838.	3.14E-01	2025.	1.15E+00	2179.	2.39E+00
Order	6.0	1685.	9.62E+00	1856.	8.15E+00	1997.	6.22E+00
Order	6.5	1555.	2.42E-01	1713.	1.44E+00	1844.	3.06E+00
Order	7.0	1444.	1.09E+01	1591.	1.45E+01	1712.	1.76E+01
Order	7.5	1348.	8.84E-01	1485.	6.43E+00	1598.	1.46E+01
Order	8.0	1264.	1.03E+01	1392.	1.37E+01	1498.	1.66E+01
Order	8.5	1189.	2.83E-01	1310.	1.29E+00	1410.	2.72E+00
Order	9.0	1123.	7.85E+00	1237.	6.65E+00	1332.	5.08E+00
Order	9.5	1064.	3.55E-01	1172.	8.97E-01	1262.	1.78E+00
Order	10.0	1011.	3.74E+00	1114.	4.99E+00	1198.	6.07E+00
Order	10.5	963.	1.55E+00	1061.	2.16E+00	1141.	3.02E+00
Order	11.0	919.	9.52E-01	1012.	1.30E+00	1089.	1.69E+00
Order	11.5	879.	3.84E-01	968.	6.33E-01	1042.	1.08E+00
Order	12.0	842.	5.55E+00	928.	4.71E+00	999.	3.60E+00

		Mode 22		Mode 23		Mode 24	
Nat.fr.-->		12230.		13034.		13363.	
		Critical speed [r/min]	Vector summation	Critical speed [r/min]	Vector summation	Critical speed [r/min]	Vector summation
Order	.5	24460.	3.70E+00	26068.	6.15E+00	26727.	7.62E+00
Order	1.0	12230.	1.68E+01	13034.	1.92E+01	13363.	2.01E+01
Order	1.5	8153.	1.40E+01	8689.	2.29E+01	8909.	2.76E+01
Order	2.0	6115.	1.19E+01	6517.	1.37E+01	6682.	1.43E+01
Order	2.5	4892.	1.81E+00	5214.	2.96E+00	5345.	3.65E+00
Order	3.0	4077.	1.69E+00	4345.	9.94E-01	4454.	6.81E-01
Order	3.5	3494.	5.53E-01	3724.	6.50E-01	3818.	7.12E-01
Order	4.0	3057.	3.32E+00	3259.	4.02E+00	3341.	4.38E+00
Order	4.5	2718.	7.09E+00	2896.	1.13E+01	2970.	1.35E+01
Order	5.0	2446.	1.06E+01	2607.	1.22E+01	2673.	1.28E+01
Order	5.5	2224.	2.82E+00	2370.	4.66E+00	2430.	5.77E+00
Order	6.0	2038.	5.57E+00	2172.	3.19E+00	2227.	2.15E+00
Order	6.5	1882.	3.62E+00	2005.	6.01E+00	2056.	7.44E+00
Order	7.0	1747.	1.84E+01	1862.	2.11E+01	1909.	2.21E+01
Order	7.5	1631.	1.74E+01	1738.	2.86E+01	1782.	3.44E+01
Order	8.0	1529.	1.74E+01	1629.	1.99E+01	1670.	2.09E+01
Order	8.5	1439.	3.21E+00	1533.	5.32E+00	1572.	6.59E+00
Order	9.0	1359.	4.55E+00	1448.	2.61E+00	1485.	1.76E+00
Order	9.5	1287.	2.08E+00	1372.	3.42E+00	1407.	4.23E+00
Order	10.0	1223.	6.38E+00	1303.	7.41E+00	1336.	7.84E+00
Order	10.5	1165.	3.34E+00	1241.	4.62E+00	1273.	5.30E+00
Order	11.0	1112.	1.83E+00	1185.	2.48E+00	1215.	2.86E+00
Order	11.5	1063.	1.25E+00	1133.	1.98E+00	1162.	2.42E+00
Order	12.0	1019.	3.23E+00	1086.	1.86E+00	1114.	1.26E+00

		Mode 25		Mode 26		Mode 27	
Nat. fr.-->		13527.		13539.		14293.	
		Critical speed [r/min]	Vector summation	Critical speed [r/min]	Vector summation	Critical speed [r/min]	Vector summation
Order	.5	27054.	8.51E+00	27079.	8.58E+00	28585.	1.52E+01
Order	1.0	13527.	2.05E+01	13539.	2.06E+01	14293.	2.23E+01
Order	1.5	9018.	3.02E+01	9026.	3.04E+01	9528.	4.66E+01
Order	2.0	6764.	1.47E+01	6770.	1.47E+01	7146.	1.61E+01
Order	2.5	5411.	4.07E+00	5416.	4.10E+00	5717.	7.23E+00
Order	3.0	4509.	5.19E-01	4513.	5.07E-01	4764.	3.12E-01
Order	3.5	3865.	7.51E-01	3868.	7.54E-01	4084.	1.03E+00
Order	4.0	3382.	4.58E+00	3385.	4.59E+00	3573.	5.94E+00
Order	4.5	3006.	1.48E+01	3009.	1.49E+01	3176.	2.26E+01
Order	5.0	2705.	1.31E+01	2708.	1.32E+01	2859.	1.45E+01
Order	5.5	2459.	6.44E+00	2462.	6.50E+00	2599.	1.15E+01
Order	6.0	2255.	1.62E+00	2257.	1.58E+00	2382.	8.84E-01
Order	6.5	2081.	8.32E+00	2083.	8.39E+00	2199.	1.49E+01
Order	7.0	1932.	2.26E+01	1934.	2.26E+01	2042.	2.44E+01
Order	7.5	1804.	3.76E+01	1805.	3.79E+01	1906.	5.82E+01
Order	8.0	1691.	2.13E+01	1692.	2.13E+01	1787.	2.31E+01
Order	8.5	1591.	7.36E+00	1593.	7.42E+00	1681.	1.31E+01
Order	9.0	1503.	1.33E+00	1504.	1.30E+00	1588.	7.29E-01
Order	9.5	1424.	4.72E+00	1425.	4.75E+00	1504.	8.40E+00
Order	10.0	1353.	8.06E+00	1354.	8.08E+00	1429.	9.27E+00
Order	10.5	1288.	5.69E+00	1289.	5.72E+00	1361.	8.20E+00
Order	11.0	1230.	3.08E+00	1231.	3.10E+00	1299.	4.70E+00
Order	11.5	1176.	2.69E+00	1177.	2.71E+00	1243.	4.74E+00
Order	12.0	1127.	9.49E-01	1128.	9.26E-01	1191.	5.30E-01

Mode 28

Nat.fr.--> 14293.

		Critical speed [r/min]	Vector summation
Order	.5	28585.	1.52E+01
Order	1.0	14293.	2.23E+01
Order	1.5	9528.	4.66E+01
Order	2.0	7146.	1.61E+01
Order	2.5	5717.	7.23E+00
Order	3.0	4764.	3.12E-01
Order	3.5	4084.	1.03E+00
Order	4.0	3573.	5.94E+00
Order	4.5	3176.	2.26E+01
Order	5.0	2859.	1.45E+01
Order	5.5	2599.	1.15E+01
Order	6.0	2382.	8.84E-01
Order	6.5	2199.	1.49E+01
Order	7.0	2042.	2.44E+01
Order	7.5	1906.	5.82E+01
Order	8.0	1787.	2.31E+01
Order	8.5	1681.	1.31E+01
Order	9.0	1588.	7.29E-01
Order	9.5	1504.	8.40E+00
Order	10.0	1429.	9.27E+00
Order	10.5	1361.	8.20E+00
Order	11.0	1299.	4.70E+00
Order	11.5	1243.	4.74E+00
Order	12.0	1191.	5.30E-01

ONGERUBRICEERD

REPORT DOCUMENTATION PAGE		
1. DEFENCE REPORT NUMBER (MOD-NL) TD 96 - 0103	2. RECIPIENT'S ACCESSION NUMBER	3. PERFORMING ORGANIZATION REPORT NUMBER 95-CMC-R0615
4. PROJECT/TASK/WORK UNIT NO. 42775649	5. CONTRACT NUMBER A94/KM/125	6. REPORT DATE December 31, 1995
7. NUMBER OF PAGES 67 (incl. appendix, excl. RDP and distribution list)	8. NUMBER OF REFERENCES 15	9. TYPE OF REPORT AND DATES COVERED Final Report
10. TITLE AND SUBTITLE Torsional vibration analysis of a long propeller shaft system driven by two diesel engines (Diesel-direct system)		
11. AUTHOR(S) H.S.T. Brockhoff, P.P.M. Lemmen		
12. PERFORMING ORGANIZATION NAME(S) AND ADDRESS(ES) Centre for Mechanical Engineering Leeghwaterstraat 5 2628 CA DELFT, The Netherlands		
13. SPONSORING/MONITORING AGENCY NAME(S) AND ADDRESSES(S) Sponsor: Netherlands Ministry of Defence Monitoring agency: TNO Defence Research, Schoemakerstraat 97, 2628 VK DELFT, The Netherlands		
14. SUPPLEMENTARY NOTES The Centre for Mechanical Engineering is part of TNO Building and Construction Research The classification designation ONGERUBRICEERD is equivalent to UNCLASSIFIED.		
15. ABSTRACT (MAXIMUM 200 WORDS, 1044 BYTES) The report presents a torsional vibration analysis of a ship's propeller shaft system driven by two diesel engines. The propeller shaft is unusual long: 74 meters. The results of the analysis are evaluated on basis of the specifications of Lloyd's Register of Shipping. Further, a comparison has been made with similar results using an electric propulsion system.		
16. DESCRIPTORS ship design propeller shaft vibration analysis		IDENTIFIERS ship propulsion system
17a. SECURITY CLASSIFICATION (OF REPORT) ONGERUBRICEERD	17b. SECURITY CLASSIFICATION (OF PAGE) ONGERUBRICEERD	17c. SECURITY CLASSIFICATION (OF ABSTRACT) ONGERUBRICEERD
18. DISTRIBUTION/AVAILABILITY STATEMENT Unlimited availability, requests shall be referred to sponsor		17d. SECURITY CLASSIFICATION (OF TITLES) ONGERUBRICEERD

ONGERUBRICEERD

Distributielijst bij rapport 95-CMC-R0615
Instituut: TNO Bouw, CMC
Project A94/KM/125

DWOO	1
HWO-Centrale Organisatie	(B)
HWO-KM	1
HWO-KL	(B)
HWO-KLu	(B)
Projectbegeleider DMKM, afd. Platformsystemen, ir. I.P. Barendregt	4
Koninklijk Instituut voor de Marine ir. C.A.J. Tromp	2
Stork-Wärtsilä Diesel ing. K. van Dijk	1*
Bureau TNO-DO	1
Bibliotheek KMA	3
Centrum voor Mechanische Constructies	8

(B) = Beperkt rapport

* Dit exemplaar hebben wij zelf reeds verzonden aan Stork-Wärtsilä Diesel.