

REPORT DOCUMENTATION PAGE			Form Approved OMB No. 0704-0188	
<p>Public reporting burden for this collection of information is estimated to average 1 hour per response, including the time for reviewing instructions, searching existing data sources, gathering and maintaining the data needed, and completing and reviewing the collection of information. Send comments regarding this burden estimate or any other aspect of this collection of information, including suggestions for reducing this burden, to Washington Headquarters Service, Directorate for Information Operations and Reports, 1215 Jefferson Davis Highway, Suite 1204, Arlington, VA 22202-4302, and to the Office of Management and Budget, Paperwork Reduction Project (0704-0188), Washington, DC 20503.</p>				
1. AGENCY USE ONLY (Leave blank)	2. REPORT DATE	3. REPORT TYPE AND DATES COVERED		
	6/1/96	Progress 1/1/96-6/1/96		
4. TITLE AND SUBTITLE			5. FUNDING NUMBERS	
An Investigation of the Channel Crosstalk in Optical Heterodyne Controlled Phased Array Radars			Award # N00014-95-I-0494	
6. AUTHOR(S)				
Alan Rolf Mickelson				
7. PERFORMING ORGANIZATION NAME(S) AND ADDRESS(ES)			8. PERFORMING ORGANIZATION REPORT NUMBER	
The Regents of the University of Colorado Campus Box 19 Boulder, CO 80309-0019				
9. SPONSORING / MONITORING AGENCY NAME(S) AND ADDRESS(ES)			10. SPONSORING / MONITORING AGENCY REPORT NUMBER	
William J. Stachnik, ONR313 Office of Naval Research 800 N. Quincy Street Arlington, VA 22217-5000				
11. SUPPLEMENTARY NOTES				
12. DISTRIBUTION / AVAILABILITY STATEMENT			13. DISTRIBUTION CODE	
Approved for public release; distribution unlimited.				
14. ABSTRACT (Maximum 200 words)				
<p>The principal objective of this project is to develop a calibrated simulation model which can accurately predict the effects on overall phased array system performance when conventional subsystems are replaced with optically assisted subsystems. The fabrication of high quality integrated optical components requires an accurate prediction of device performance. This is especially true in the fabrication of necessary components such as resonators where commercial software fails to predict the slot mode resonances. This is the first time a spatial mapping of the r-coefficient has been performed. Defects present a clearer picture of the inner workings of optical waveguide crystals such as LiNbO₃. This is especially true of crucial quantities such as crosstalk. The effect of proton exchange may play a greater role than previously expected since we found "cracks" of defects propagating as far as 200 μm into the substrate.</p>				
14. SUBJECT TERMS			15. NUMBER OF PAGES	
Microwave Optics, Phased Array Radar, Resonator, Modulator Active Nonlinear Circuit			12	
			16. PRICE CODE	
17. SECURITY CLASSIFICATION OF REPORT	18. SECURITY CLASSIFICATION OF THIS PAGE	19. SECURITY CLASSIFICATION OF ABSTRACT	20. LIMITATION OF ABSTRACT	
Unclassified	Unclassified	Unclassified	Unlimited	

Standard Form 298 (Rev. 2-89)

19960613 072

DISCLAIMER NOTICE

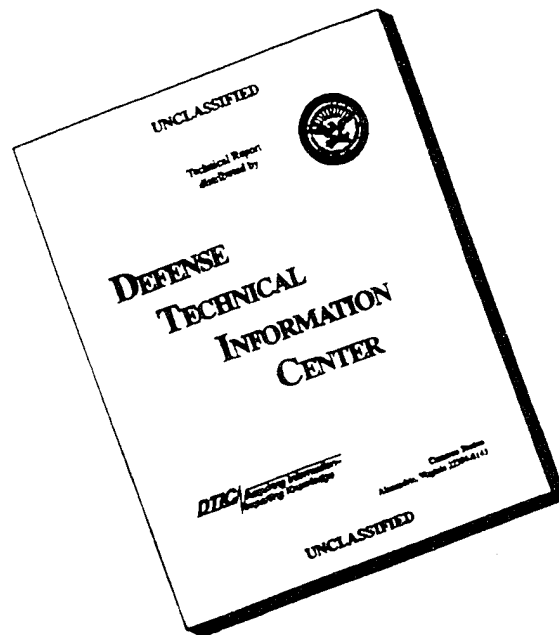

THIS DOCUMENT IS BEST QUALITY AVAILABLE. THE COPY FURNISHED TO DTIC CONTAINED A SIGNIFICANT NUMBER OF PAGES WHICH DO NOT REPRODUCE LEGIBLY.

PROGRESS REPORT

for Office of Naval Research
for the period January 1, 1996 through June 1, 1996

1. **Contract Title:**

Phenomenological Modeling of Optically Assisted Phased Array Radar

Principal Investigator:

Professor Alan R. Mickelson
Department of Electrical and Computer Engineering
Campus Box 425
University of Colorado
Boulder, CO 80309-0425

Program Manager:

Dr. Arthur Jordan

2. **Technical Objectives:**

The principal objective of this project remains the same and is to develop a calibrated simulation model which can accurately predict the effects on overall phased array system performance when conventional subsystems are replaced with optically assisted subsystems.

3. **Approach:**

The approach thus far has been to incorporate time efficient computer aided design (CAD) tools to model the entire system performance of an optically assisted phased array system. The CAD simulator will consist of three levels of phased array system analysis; a system level consisting of functional blocks, an equivalent circuit level for each of the system blocks, and a component level. Our approach has been to integrate existing phenomenological models of the separate system blocks into a computer friendly environment which can then perform an accurate overall optically assisted system performance.

4. **Accomplishments:**

Various components of single side band (SSB) modulator have been designed and fabricated. The designs used for this task employed a commercially available microwave design software (MDS) developed by Hewlett Packard for the microwave components, while the optical modulators are fabricated using the annealed proton exchange technique. Two important observations have come from this research: 1) MDS is not sufficient for the prediction of actual device performance, and 2) Defects present in LiNbO_3 may affect device performance and these defects could also explain why device yield is not exceptionally high.

Several CPW resonators of varying feed lengths were fabricated on LiNbO_3 . Additionally, the physical geometry of the resonator $\lambda/2$ structure was also varied while keeping its impedance the same. Figure 1 demonstrates the resonator structure. The MDS predictions are shown in figures 2 and 4 while the actual

measured results are shown in fig. 3. The simulated results in fig. 4 demonstrate that mismatches in the feed impedance can create additional resonances but not the strong 10 GHz resonance. This strong resonance is probably due to the slot modes generated by the structure. We must therefore modify our analysis of these structures to include all possible excitations not just the CPW modes to be able to correctly predict device behavior.

Figure 5 shows a new experimental LST (laser scanning tomography) apparatus that allows us to observe defects in LiNbO_3 samples. Measurements on samples of proton exchanged regions (used to create optical waveguides) were performed and reveal very significant defects. The proton exchange test structure is shown in fig. 6. LST measurements have shown the presence of defects along the exchanged- unexchanged region interface in a x-cut with y-propagating and z - propagating exchange stripes. LiNbO_3 samples that were x-cut with z-propagating exchange stripes showed macroscopic cracks when examined under a microscope. The LST signature is also very similar to the macroscopic cracks observed. LST results are given in fig. 7. The results of the exchanged structures are also compared to the electrooptic sampling results depicted in fig. 8. The electrooptic sampling results reveal that proton exchange does provide a measurable electrooptic coefficient deviation.

5. Significance:

The fabrication of high quality integrated optical components requires an accurate prediction of device performance. This is especially true in the fabrication of necessary components such as resonators where commercial software fails to predict the slot mode resonances.

This is the first time a spatial mapping of the r-coefficient has been performed. Defects present a clearer picture of the inner workings of optical waveguide crystals such as LiNbO_3 . This is especially true of crucial quantities such as crosstalk. The effect of proton exchange may play a greater role than previously expected since we found "cracks" of defects propagating as far as 200 μm into the substrate.

6. Future Efforts:

- 1) Future work includes describing some anomalous resonances that we saw in the LiNbO_3 single sideband structure. Since the experimental results indicate the need for better modeling tools for the design and analysis of CPW resonators, efforts are underway which will determine the impedances seen by different feed point structures. The technique will use elements of the method of moments.
- 2) A better understanding of the defect characteristics and their role in device performance is being pursued.

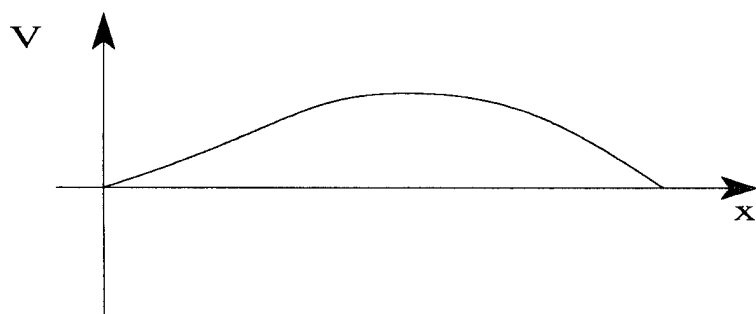
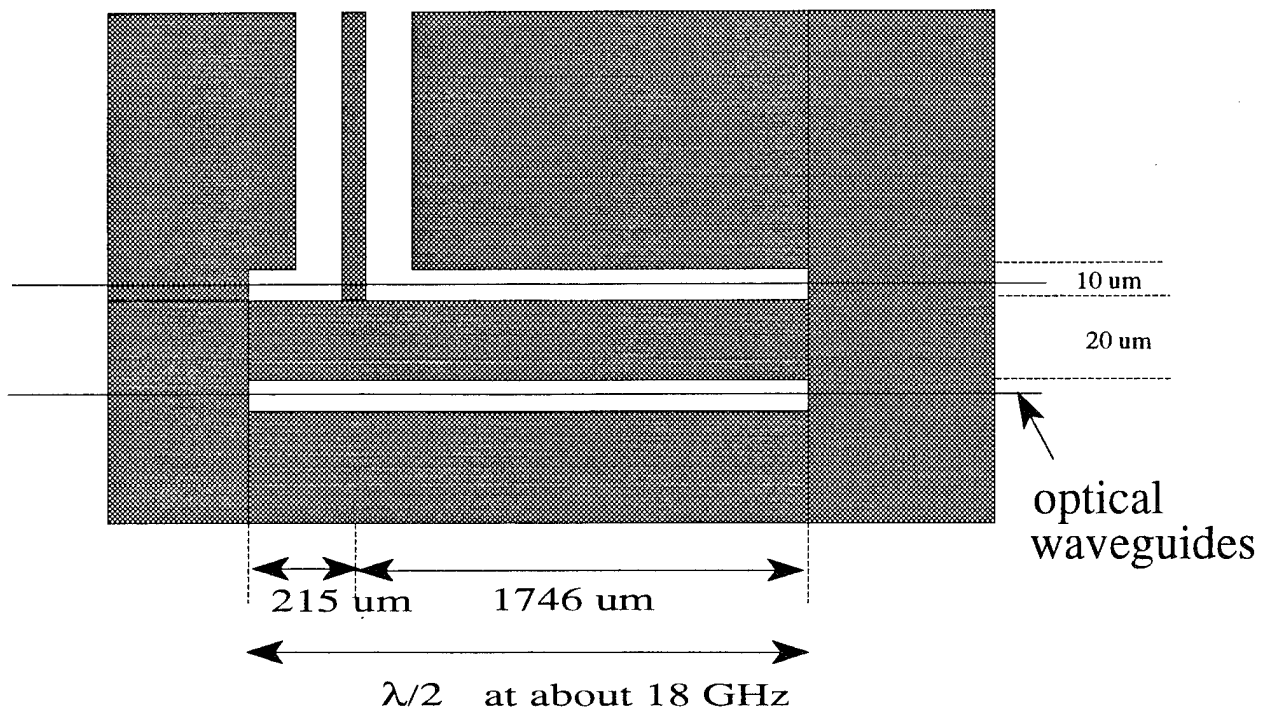
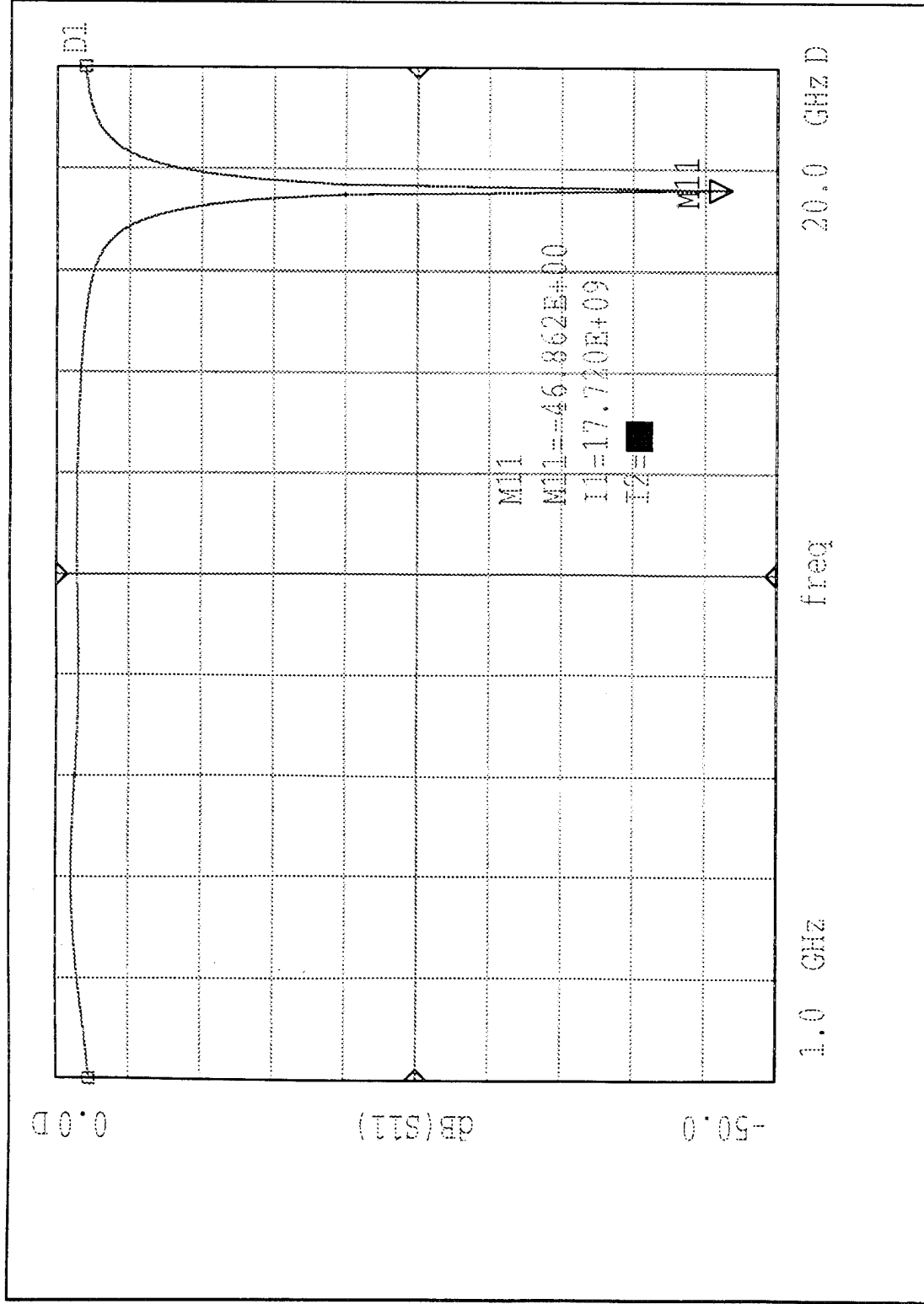

Figure 1: CPW resonator

Dataset=DAT2_1

Qualifier=■



Trace1=dB(S[1,1])

Fig 3: CPW resonator response

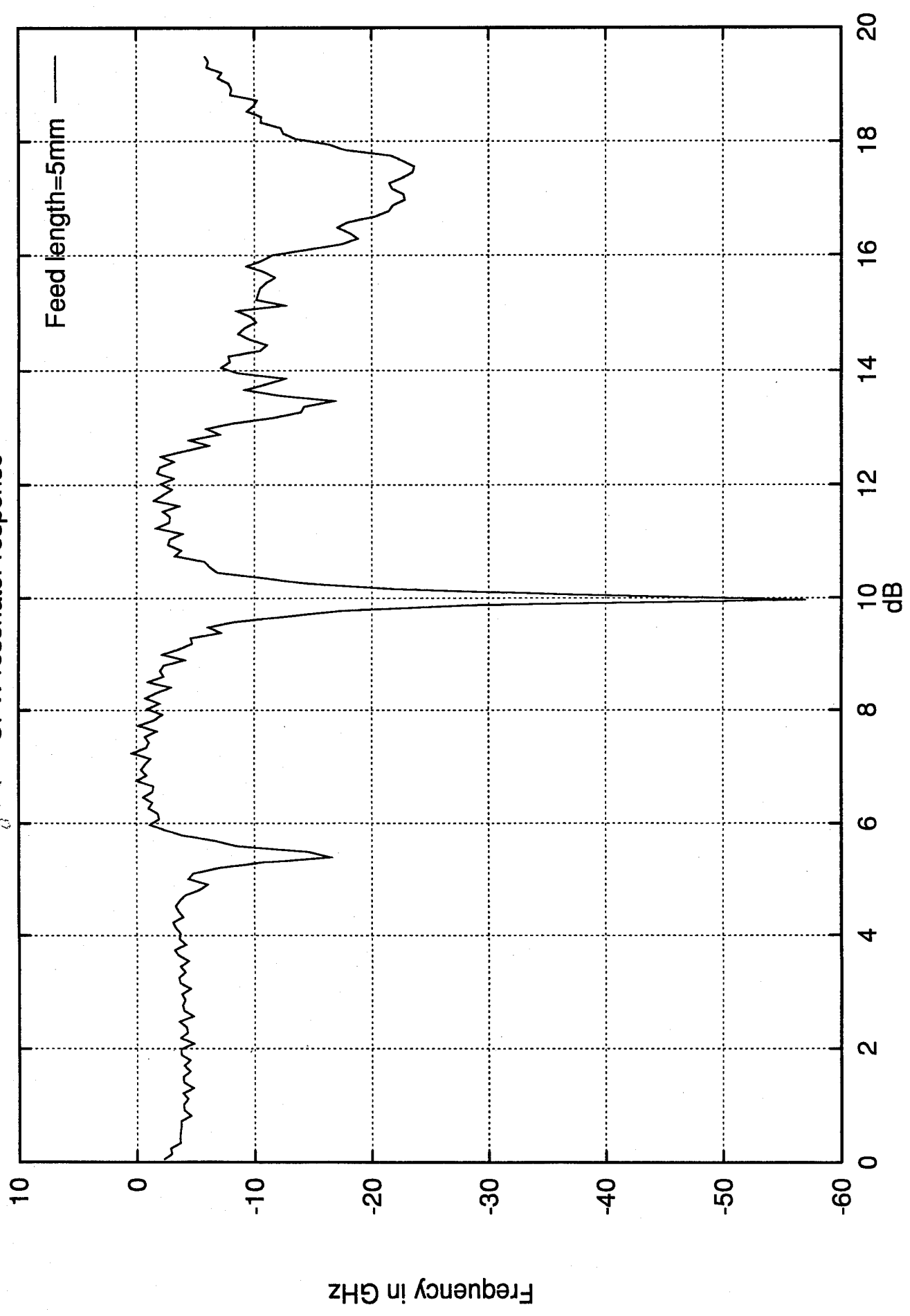

Dataset=DAT2_1

Qualifier=■

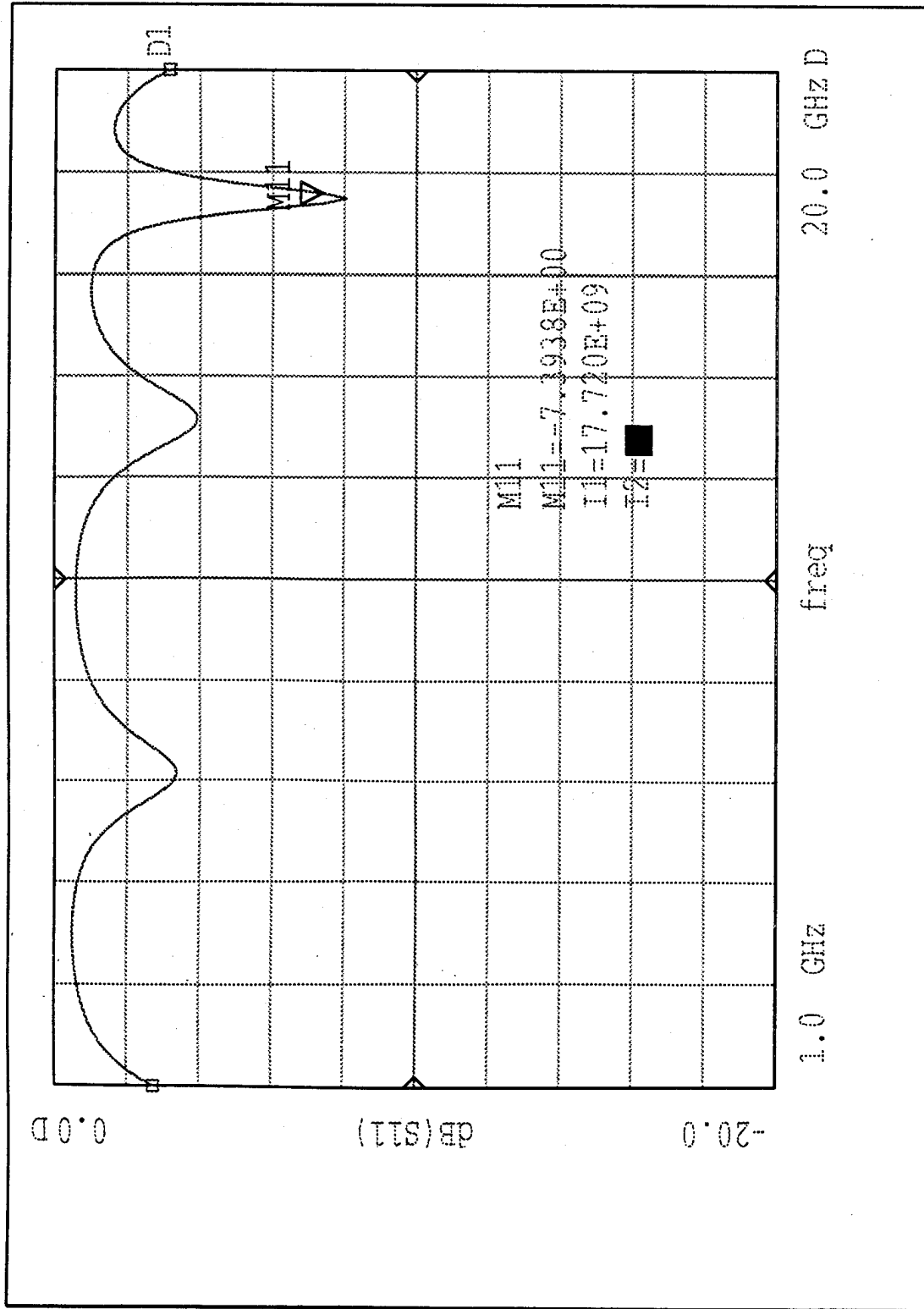

Trace1=dB(S[1,1])

Fig 4: *MUS SH...*
Plot of S11 and S21

Experimental Setup for Laser Scanning Tomography

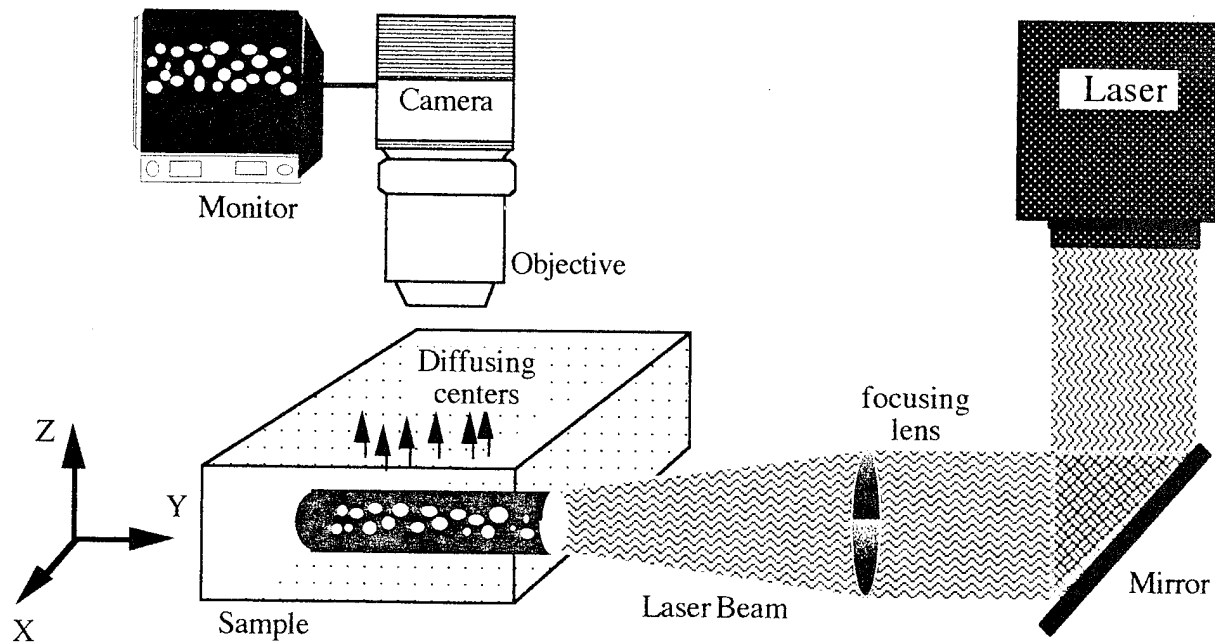

Characteristics :

COHU CCD Camera : 754(H) X 488(V)

Maximum of resolution : 0.3 (H) X 0.4 (V)

Sensitivity : High sensitivity due to the technique of dark field and high sensitivity of the camera

Maximum density of defects detected is about $9 \times 10^{12} / \text{cm}^3$

Step #1: Proton exchange sample

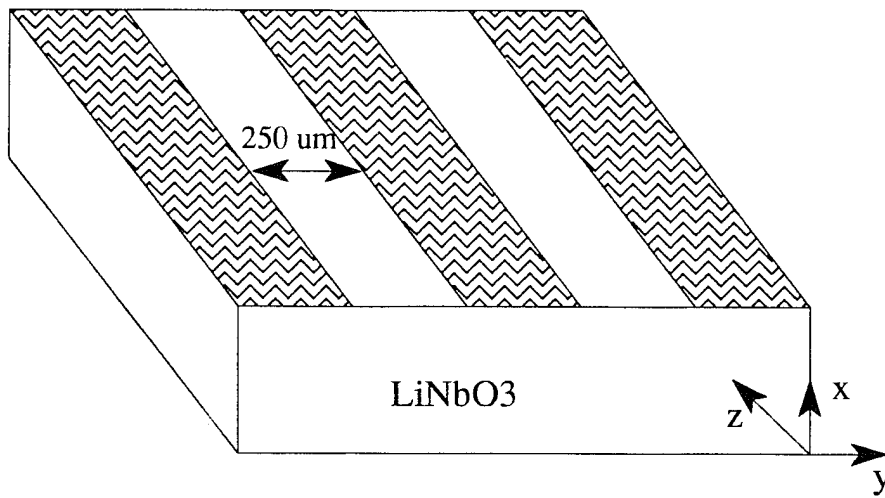

Step #2: Evaporate electrodes for EO sampling

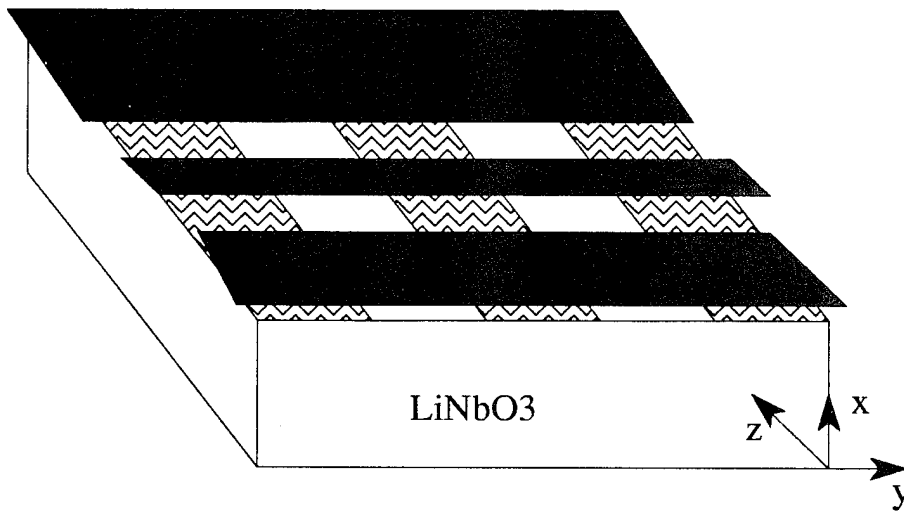
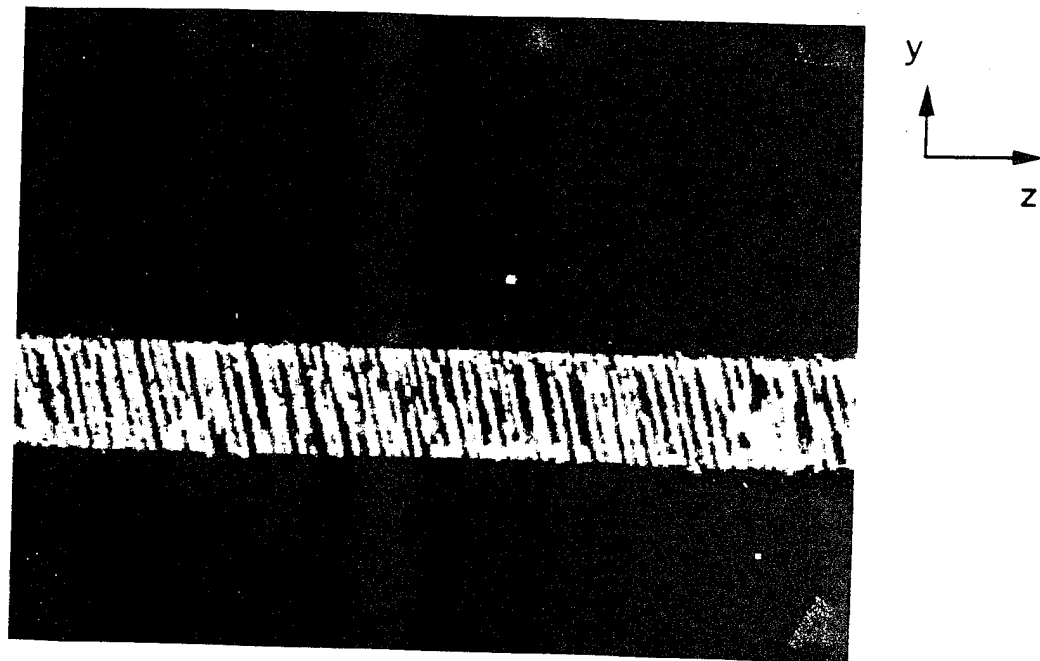

Figure 6 Experiment to map spatial variation of r-coefficient in LN samples due to proton exchange

Figure 1 LST signature of z-directed exchange stripe



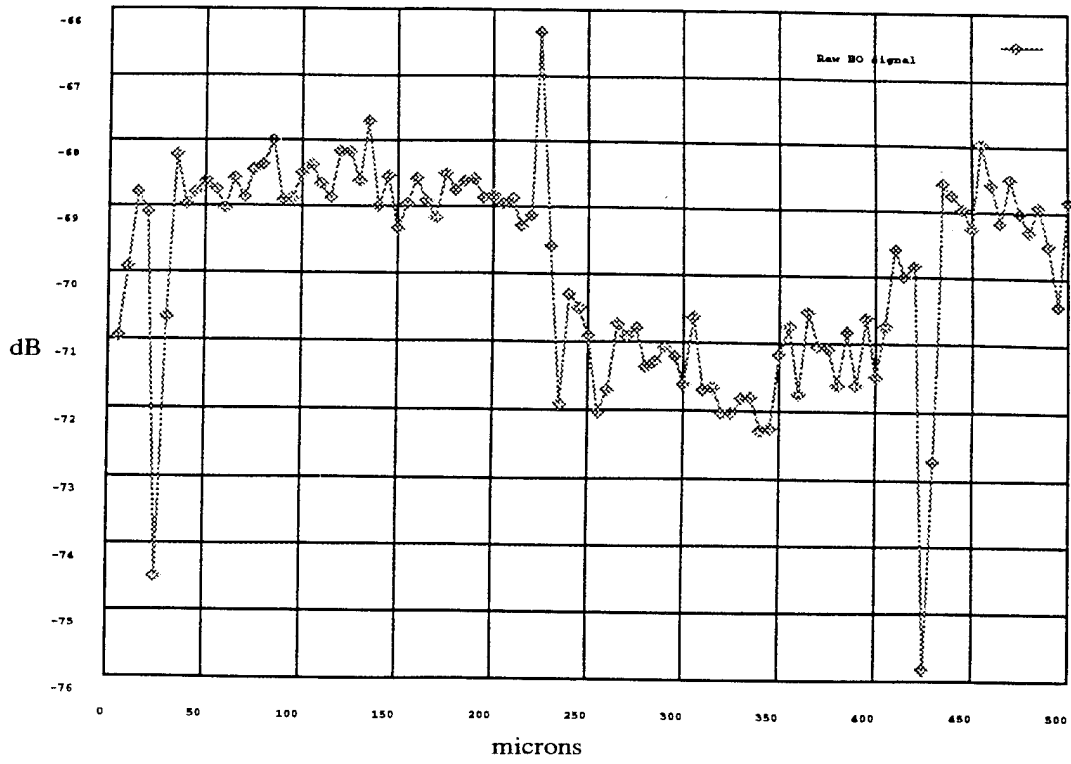

Figure 8: EO signal variation across exchanged and un-exchanged regions

Fig 8

7. Publications and Presentations Partially Supported Under This Grant January 1, 1996 through June 1, 1996

- (1) K. Y. Chen, P. B. Biernacki, S. Buchheit, and A. R. Mickelson, "Noninvasive Experimental Determination of Charge and Voltage Distributions on an Active Surface," *IEEE Transactions on MTT*, Vol. 44, 7, pp. 1-10, July, 1996
- (2) P. D. Biernacki and A. R. Mickelson, "Electrooptic sampling for measuring proton (H+) exchanged induced defects in LiNbO₃," *Ins. Phys. Conf. Ser No. 149*. pp. 161-164, 1996
- (3) A. R. Mickelson, "Defect Studies in LiNbO₃," *Ins. Phys. Conf. Ser No. 149*. pp. 7-12, 1996
- (4) D. Benhaddou and A. R. Mickelson, " Laser Scanning Tomography Studies of Lithium Niobate Crystals," *Ins. Phys. Conf. Ser No. 149*. pp. 139-142, 1996
- (5) P. D. Biernacki, Henry Lee, and A. R. Mickelson, "Evaluation of Defect Related Diffusion in Semiconductors by Electrooptic Sampling," *IEEE J. Quantum Electronics* Vol. 1, Dec. 4, 1995, pp. 1037-1046.
- (6) P. D. Biernacki and A. R. Mickelson, "Impedance Matching of Laser Diodes Using Packaged Microstrip Lines: Active and Passive," *IEEE Lasers and Electro-Optic Society* vol. 1, **OPMR3.1** pp. 238-239, Oct. 30-Nov. 3, 1995.
- (7) Raghu Narayan, and Alan Mickelson, "Design and Fabrication of Single Side Band (SSB) optical Modulator," *Digest Of The LEOS Summer Topical Meeting*, **ThB4** pg. 34, (1995).

8. Participants:

Professor Alan R. Mickelson
Paul Biernacki
Raghu Narayan