

IOC Advance Planning Briefing for Industry

US Army Research, Development & Engineering Center

(ARDEC)

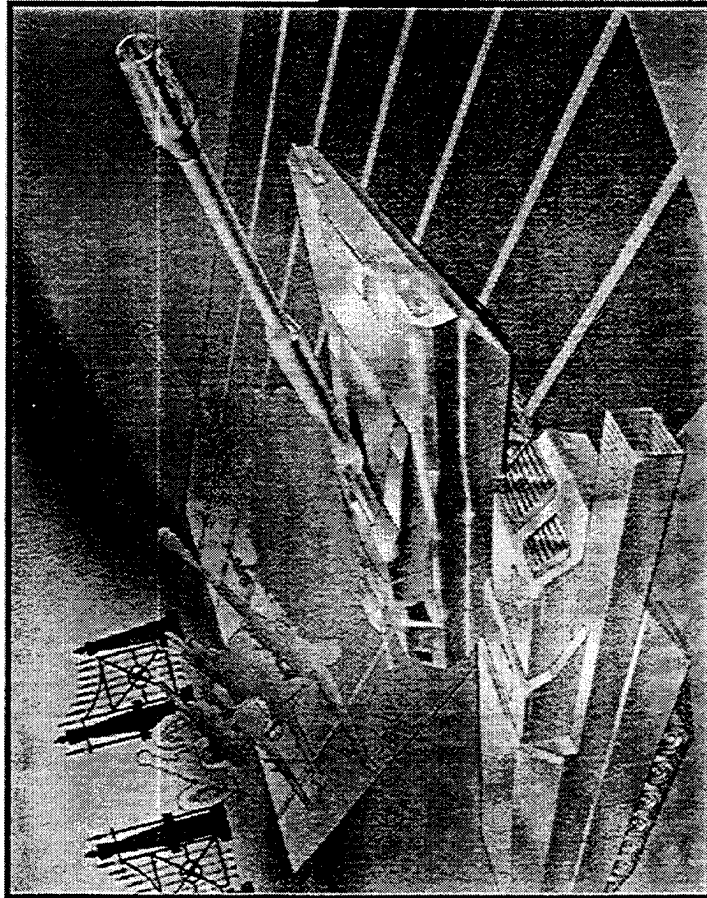
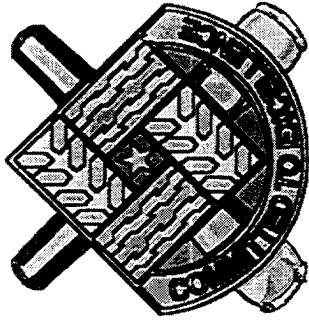

19960607 008

BG James W. Bo
Commanding General

DISTRIBUTION STATEMENT R
Approved for public release
Distribution Unlimited

Briefing Outline

■ This is ARDEC

■ The Future

■ Summary

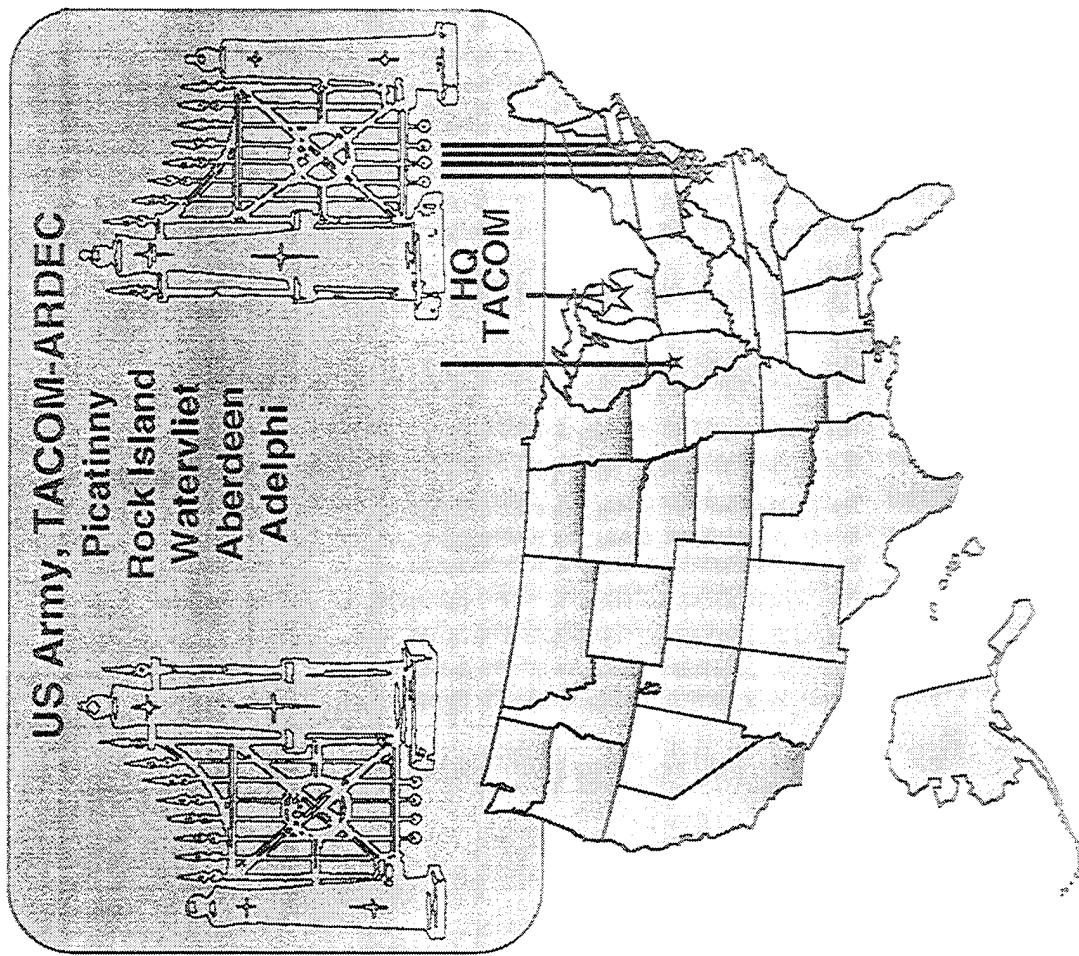

DISCLAIMER NOTICE

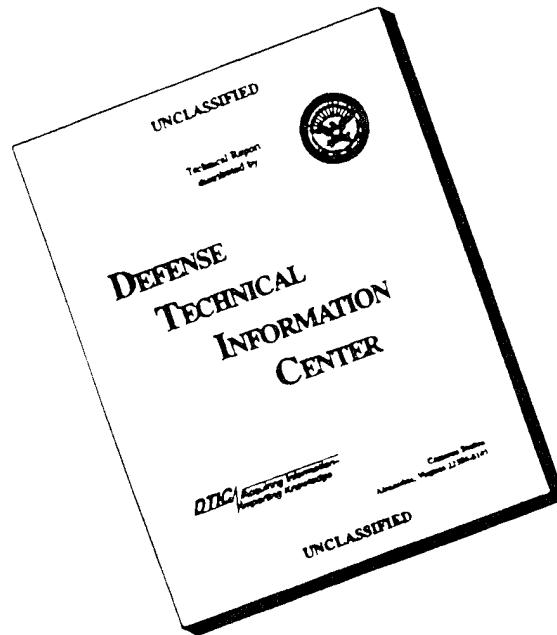

THIS DOCUMENT IS BEST QUALITY AVAILABLE. THE COPY FURNISHED TO DTIC CONTAINED A SIGNIFICANT NUMBER OF PAGES WHICH DO NOT REPRODUCE LEGIBLY.



ARDEC'S VISION

Provide Our Fighting Forces
With The Most Advanced
Armament Materiel To Assure
Victory In Combat At The
Lowest Cost And In The Shortest
Possible Time.

Customers Define Quality

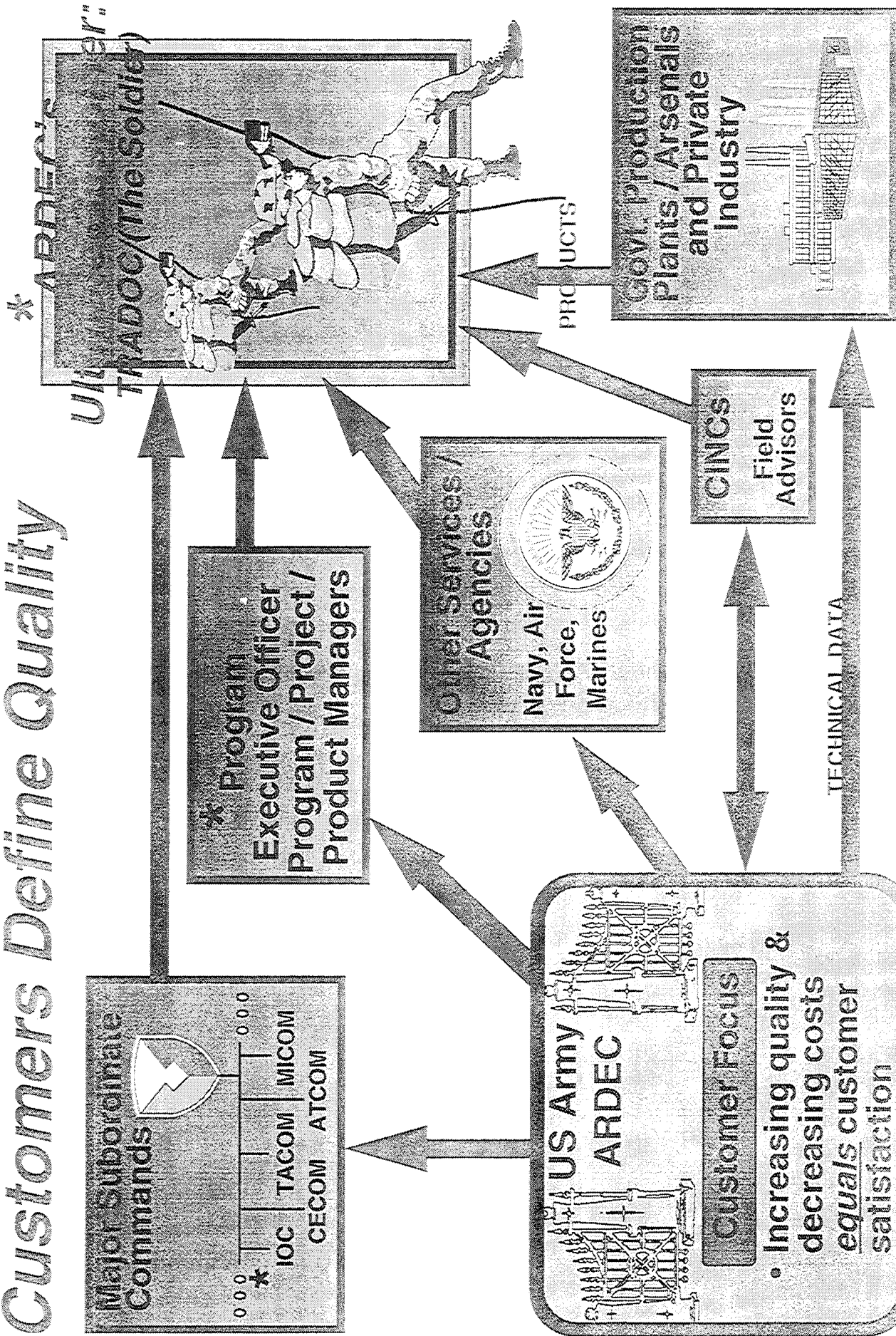

* Major Customers

ARDEC Financial Restructuring

BACKGROUND

- Customer Perspective = Costs Too High
- Internal PEG Study = Process/Augmentation Issues
- External AMCMEA Review = Confirmed PEG Study
- Teams Formed = Defined Goals & Objectives
- ✓ Financial Restructuring Team Chartered
 - Become the Most Cost Effective RDEC in AMC
 - Define Overhead & Reduce It
 - Fix Process/Augmentation Issues
 - Lower Customer Costs
 - Push Continuous Improvement

ARDEC Financial Restructuring

WHAT THIS MEANS

- ARDEC is Fully Committed to Our Long Term Future, Reducing Customer Costs, & Strong Financial Integrity
 - » Cost Discipline Process Installed
 - » Major Reductions to Cost and Personnel in Process - RIF Package Submitted
 - » ARDEC and Picatinny Community Will Deliver High Quality - High Value - Cost Managed Products and Services
 - » Restructuring Will Continue to Achieve Further Cost Reductions

The New, Slimmed Down & Improved, Team Picatinny

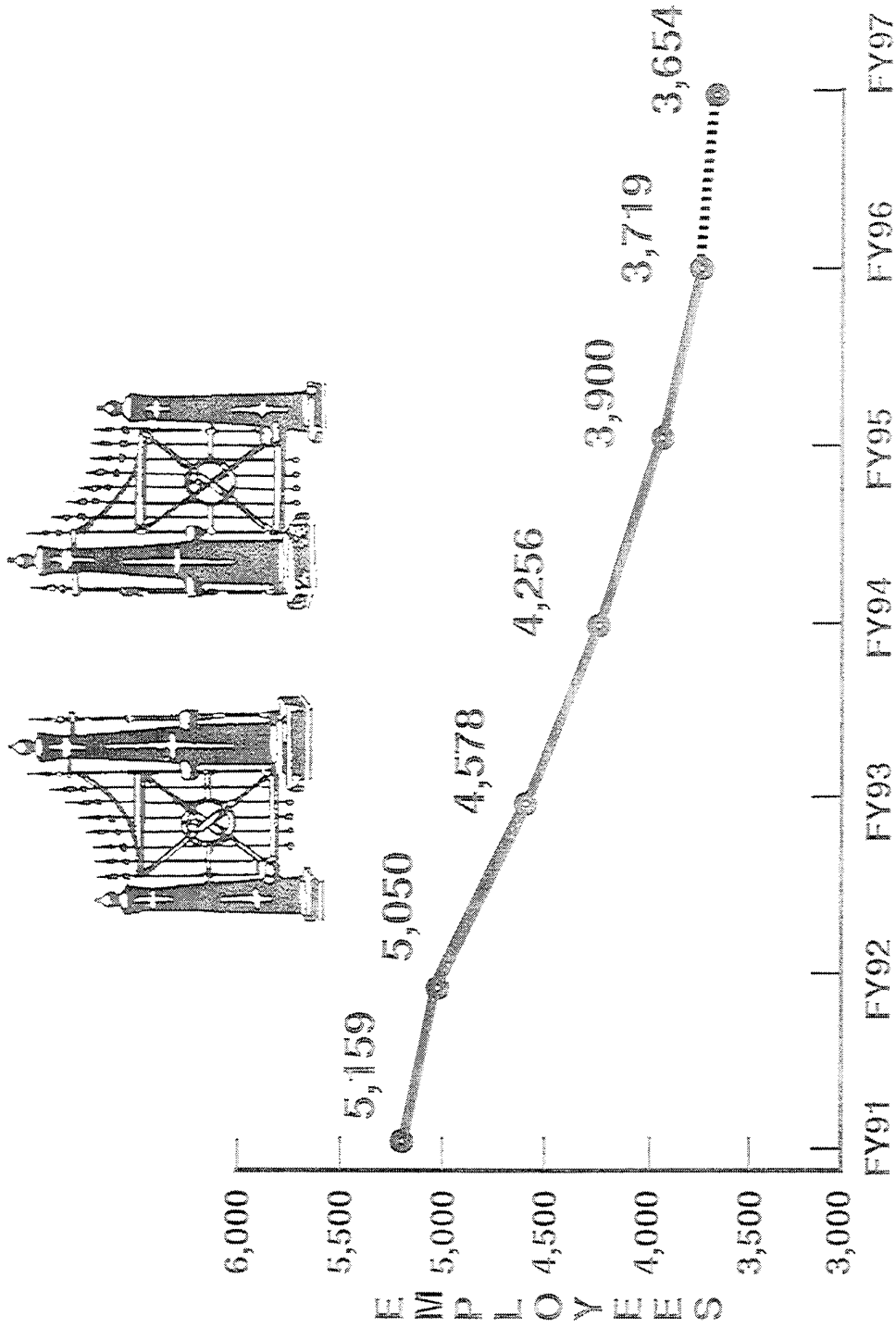

New ideas to maintain our skilled workforce and quality facilities

- Dual-Use Partnering
 - Cooperative Research and Development Agreements (CRADAs) with Industry and Academia
 - MOU's with Other Federal Agencies, State & Local
 - Picatinny Innovation Center (already in place)
 - County Industrial Park (new idea)
 - Manufacturing Technology Center (new idea)

- Facility Outleasing

What is Dual-Use?

- A process by which DoD partners with the U.S. industrial base towards affordable defense procurement

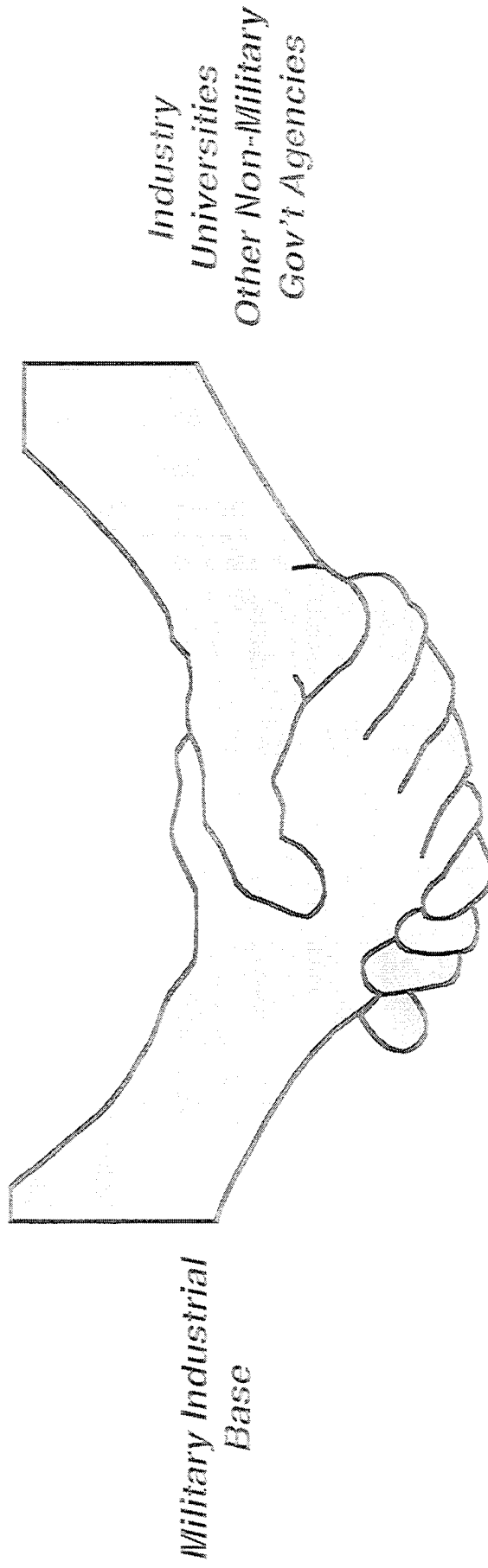

National Industrial Base

Automated Baggage Inspection System

Tomographic X-Ray Imaging Spectroscopy (TXIS)

- U.S. Dept. of Agriculture requested ARDEC develop system to identify agricultural products in airline baggage
- MOU used to transfer funds
- System uses Neural Network technology to learn from examples
- Introduced color to X-Ray world (not shown here)
- Geometric constraints and high rate throughput required developing new x-ray source technology

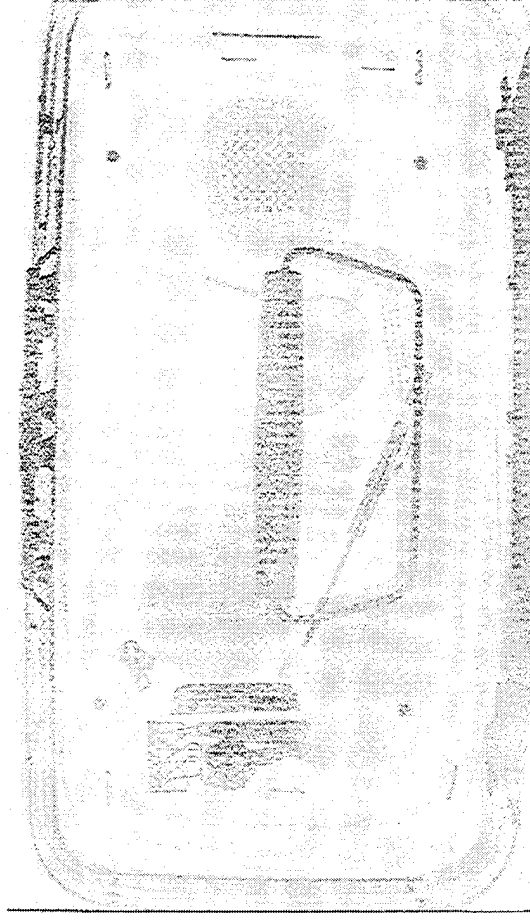
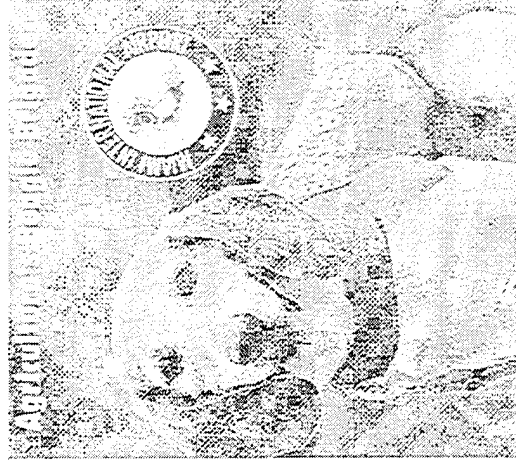

Current Technology

Future Technology

Help for Disabled Children - Health & Safety



*Jenna,
Age 2*

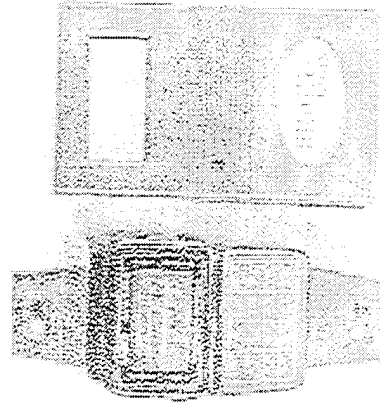

- Some children suffer from a rare form of epilepsy called "Status Epilepticus"
- This disease causes almost invisible seizures, often combined with serious breathing problems
- A unique partnership was formed between ARDEC's cannon designers at Benet Laboratories and the Center for the Disabled in Albany, New York
- Army weapon auto-loader technologies such as sensors, control logic and micro circuitry were applied to develop a device to automatically detect and warn of these almost invisible seizures.
- Worn like a bracelet, the device detects unusual vibrations characteristic of a seizure and sets off a remote alarm to warn parents or doctors.

ARDEC/Benet Laboratories CRADA Activity

- The ARDEC Benet Laboratories has established fifteen Cooperative Research and Development Agreements (CRADA's) with industry and academia to help transfer gun-related technology to the private sector.
- Recent Benet tech transfer initiatives have supported the development/improvement of industry candidates for the Army/Marine Lightweight 155mm Towed Howitzer and many other applications.

Lockheed-Martin

- Weapon Research, Design and Engineering
 - Design and Engineering of Lightweight 155mm Towed Howitzer
- ## Phoenix Engineering
- Weapon Technology
 - Design and Engineering of Lightweight 155mm Towed Howitzer

On Time

Within costs

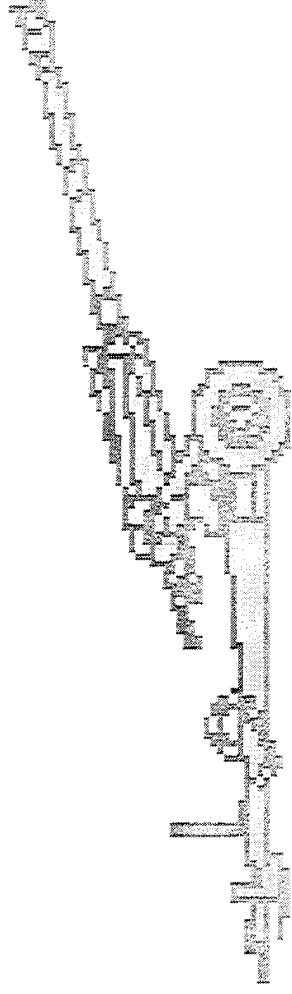

Technology Strategy for FY95 thru FY00

- **Maintain existing heavy force capabilities as “World’s Best” -**
 - Insure our continued ability to defeat potential threat Armor with state of the art ERA.
 - Improve tank system accuracy to engage at extended acquisition ranges of 2d Gen FLIR.
 - Defeat Active Protection Systems.
 - Increase Range and Accuracy of Artillery.
- **Improve the Lethality and Deployability of the Light Forces.**
 - Complete ARDEC portions of the the RFPI.
 - Improve the Lethality of the Individual Soldier.
 - Reduce Logistics Burden of the Light Forces.
 - Improve Ammo Resupply and Survivability.
- **Pursue new technology opportunities such as Less than Lethal.**
- **Maintain a solid base in smart munitions, energetics, warheads, automation, ammo logistics and the environment.**

Munitions Survivability Program

Space & resource constraints lead to high density of munitions at Entry Points

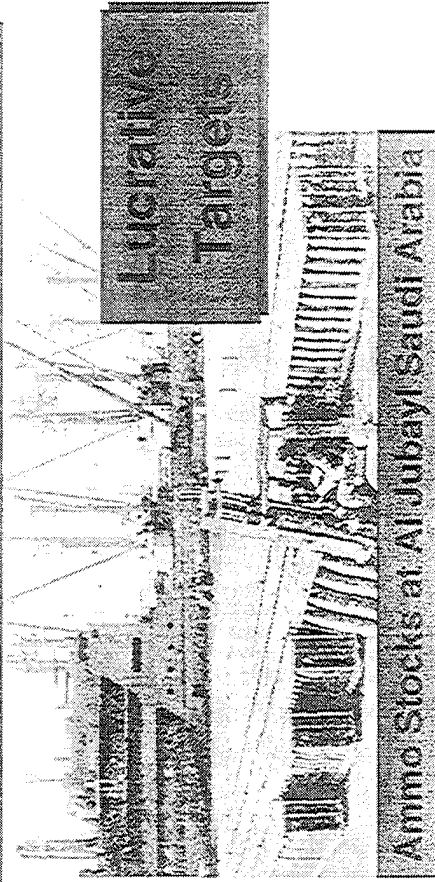

Lucrative Targets

Ammo Stocks at Al Jubayl Saudi Arabia

- OPFORs have the plans, capability & intent to inflict widespread destruction at insertion points and rear areas.

Limited Supply of High P(k) munitions.

CINC plans keyed to these decisive munitions.

Fight will be conducted with supplies on hand.



Loss of limited resupply munitions will have serious impact on military objectives.

Munitions Logistics Survivability-ACTD

Survivability

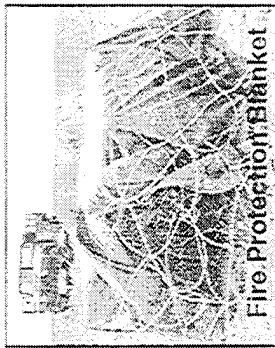

Fire Protection Blanket

Clearance

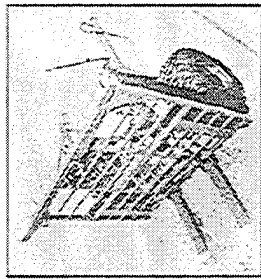

Simple Ammo Handling Equipment

Emergency Resupply

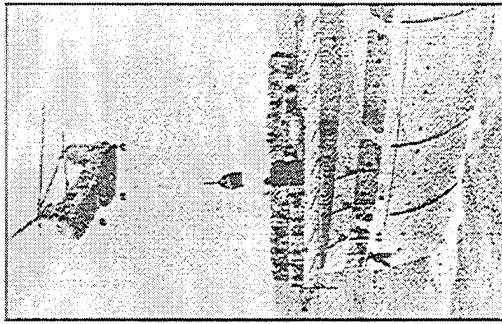

Container Handling Equipment



Rapid Barricade System



HERO

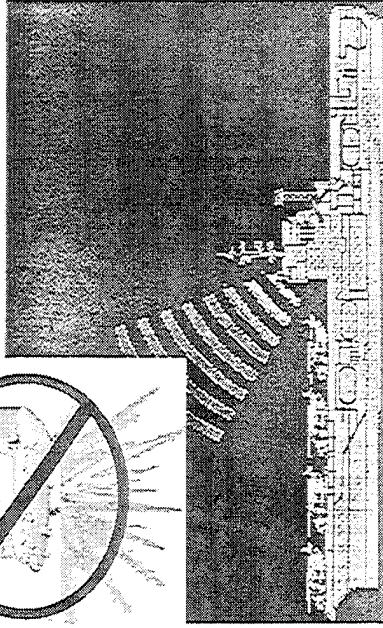
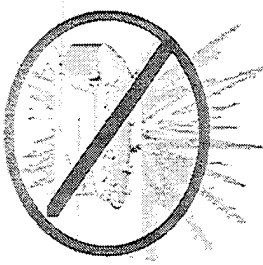

Munitions Survivability Integration

Survivable Packaging Designs

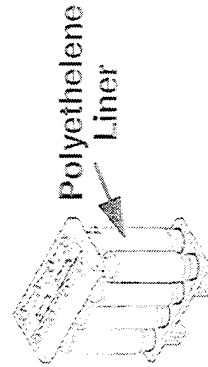

Polyethylene Liner

Aluminum Barriers between Warheads

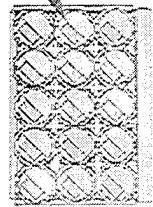

Survivable Munitions Designs



Modular Artillery Charge

Separators prevent mass reaction



Fragment Impact Test
Survivable Hellfire Graphite Motor Case

Survivable Energetics

WAM Target Defeat with PAX-2A

LX-14

PAX-2A

Equivalent Lethality

Logistics Enhancements

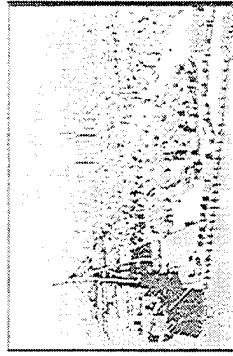

Fragment Impact Test
No detonation





ARDEC's Vision of the Future

Focused Technology Vision

21st Century Warfare

Protect the Force
 Execute Precision Strikes
 Win the Information War
 Project & Sustain Combat Power
 Dominate Maneuver

Logistics



Logistics

- * Insensitive Munitions
- * Total Asset Visibility for Stockpile Thru digitized Info
- * Rapid Rearm / Resupply

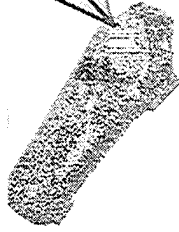

Artillery

Artillery

- * 60% Range Increase
- * 400% Rate of Fire Increase
- * 33% Manpower Reduction
- * Autonomous Operation
- * Battlefield Management & Control
- * Increased Mobility



Armor, Infantry, SOF

Armor

- * Top Attack Capability
- * Increased Hit Probability
- * Armament Systems in Light, Deployable Tanks
- * 140mm Lethality in 120mm Caliber Cannon
- * Reduced Crew Size/Stress



Infantry & SOF

- * Destruction of Very Hard Targets w/ Minimum Troop Exposure
- * >0.5 Hit Probability at 500m for Individual Combat Weapon
- * >0.5 Burst Hit Probability at 2km for Crew Served Weapon

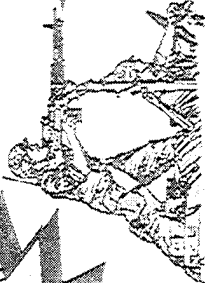

Infantry, Engineers

Mortars

- * Enhanced Mobility
- * Enhanced Fire Control
- * Extended Range
- * Precision Guided

Land Mine Warfare

- * Wide Area Munition
- * Intelligent Minefield



Building on Our Business Process

ARDEC Workforce
 Reduced in Numbers
 Trained / Skilled
 Focused on Core Competencies
 Organized to Facilitate IPPT
 Driven to Use Smart Acquisition Practices
 Best Value Contracting, etc.
 Empowered With Latest Tools
 DIS
 Virtual Prototyping, etc.

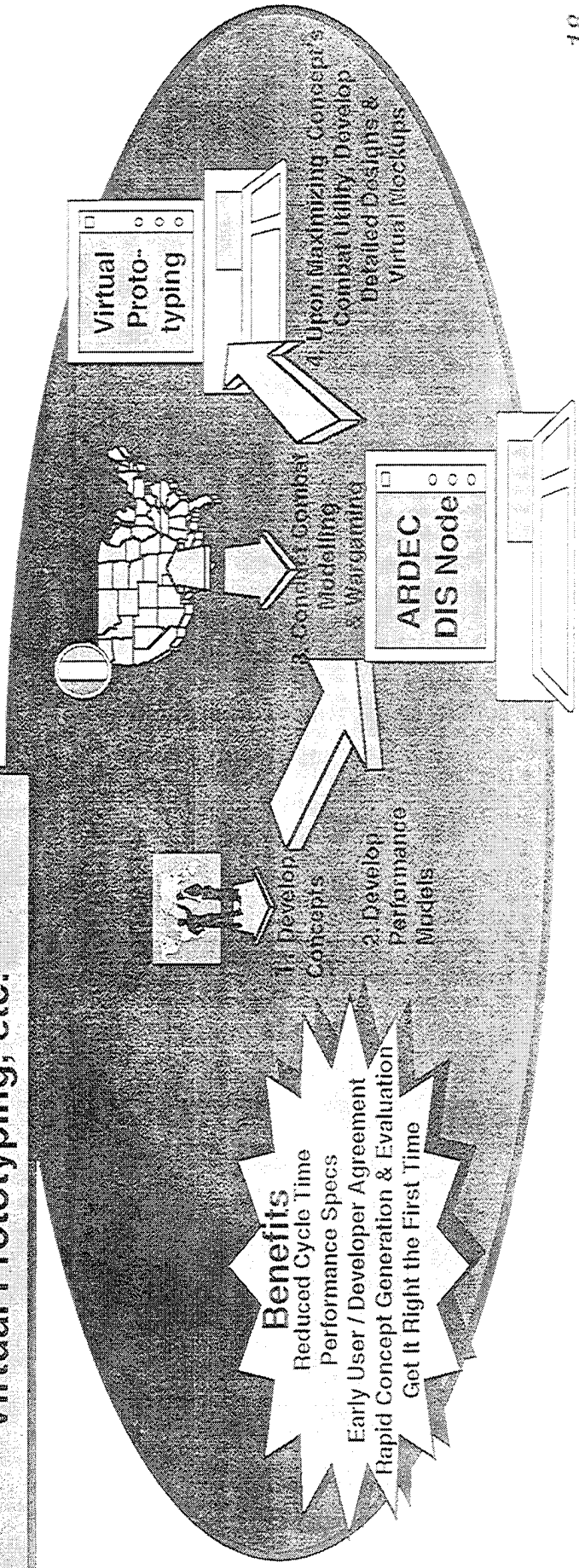
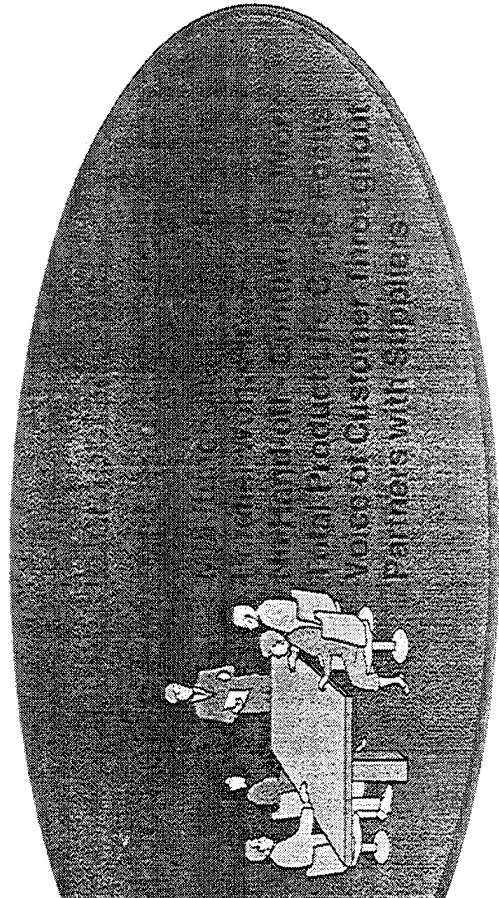

Benefits
 Reduced Cycle Time
 Performance Specs
 Early User / Developer Agreement
 Rapid Concept Generation & Evaluation
 Get It Right the First Time

Targeting Agility in Acquisition

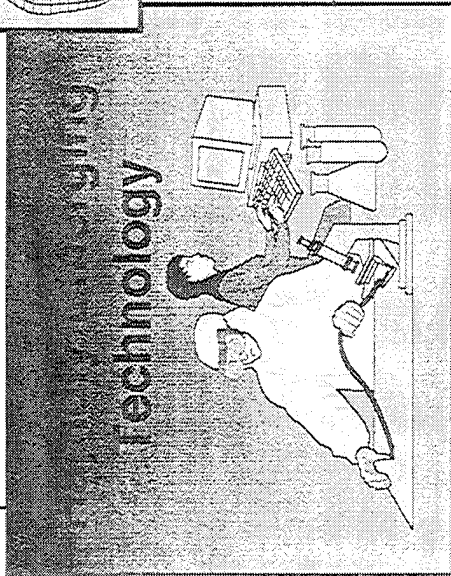
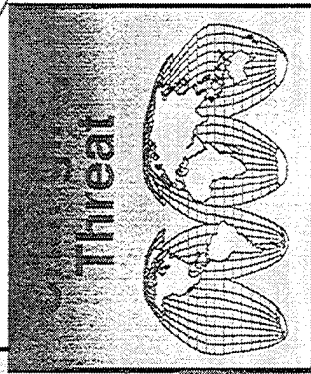
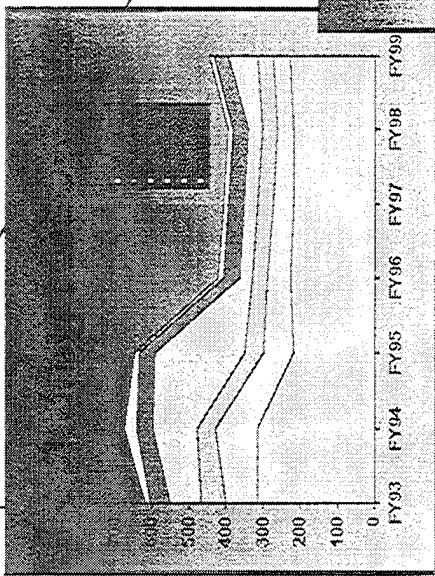

Supporting Methods
 Best Value Contracting
 Integrated Product/Process Teams (IP2T)
 Contractor Certification (R&B)
 Performance Specs
 Non-Govt. Specs & Snds
 Battle Labs / LAM
 Electronic Bulletin Board
 AFAM: DoD 5000.2-M Templates
 TDP / SOW Automation
 Roadshow Templates
 Reengineering the process
 Virtual Prototyping
 DIS
 Continuing w/ Proven Acquisition Approaches
 NDI & Leveraging
 Continuing w/ Other Cost Saving Techniques
 Value Engineering , etc.

Answering The Challenge

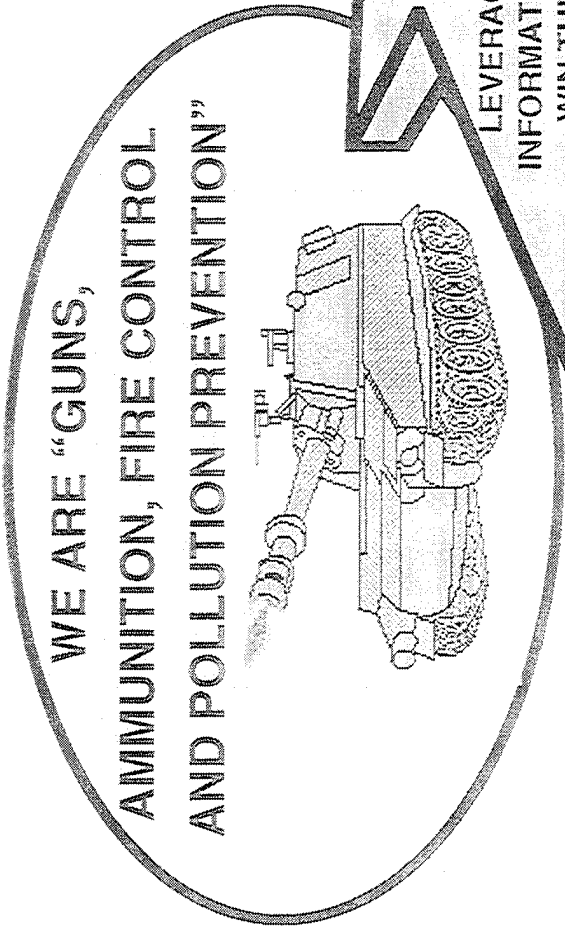

WE ARE "GUNS,
AMMUNITION, FIRE CONTROL
AND POLLUTION PREVENTION"

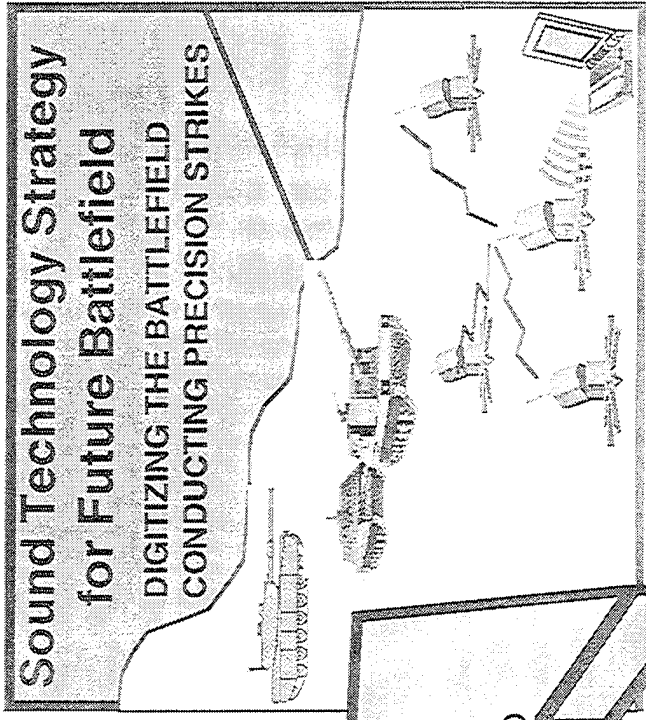

Sound Technology Strategy
for Future Battlefield
DIGITIZING THE BATTLEFIELD
CONDUCTING PRECISION STRIKES

LEVERAGING THE
INFORMATION AGE TO
WIN THE BATTLE

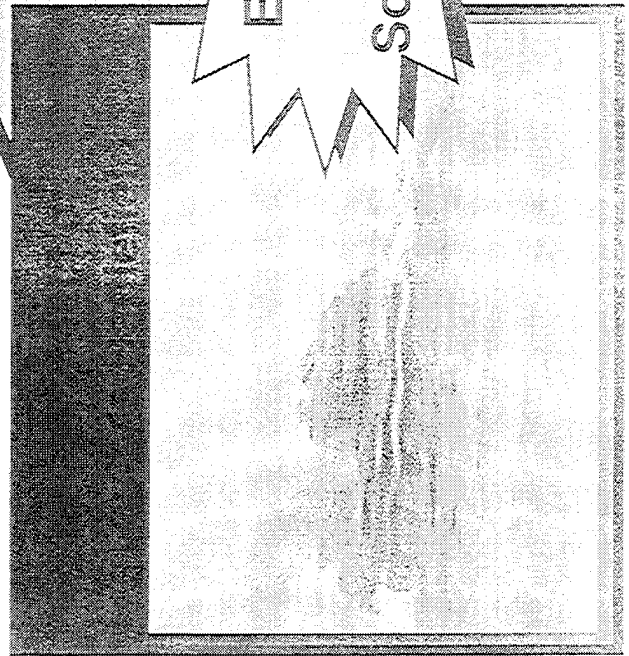

Effectiveness
Proven in
Southwest Asia

ARDEC Postured for Future
First Class Training
New Facilities
New Program Initiatives
Reduced Cost of Doing Business
Reshaped Workforce
Linked to
TRADOC
Battle Labs





Summary

ARDEC Teaming With Industry

Integrated Product Team = Our Way of Doing Business

Contractors on ARDEC Teams

ARDEC on Contractor Teams

ARDEC

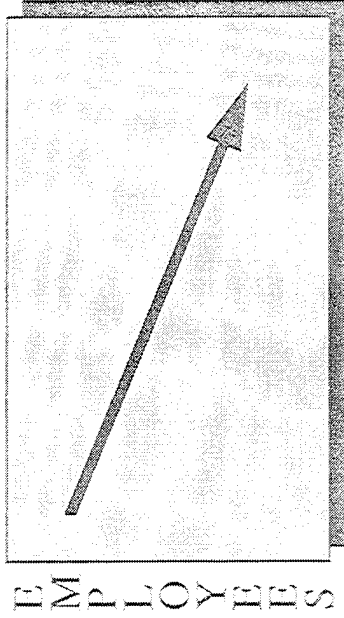

- Industry Use of ARDEC Facilities
- ATF
 - DIS Node
 - Labs
 - Excess Facilities
 - etc, etc, etc.

CIRADA'S

Bottom Line: We Are Partners

ARDEC Type Classifications Feed The Production Base

(POM Dollars (\$M) Programmed Through FY 2001)

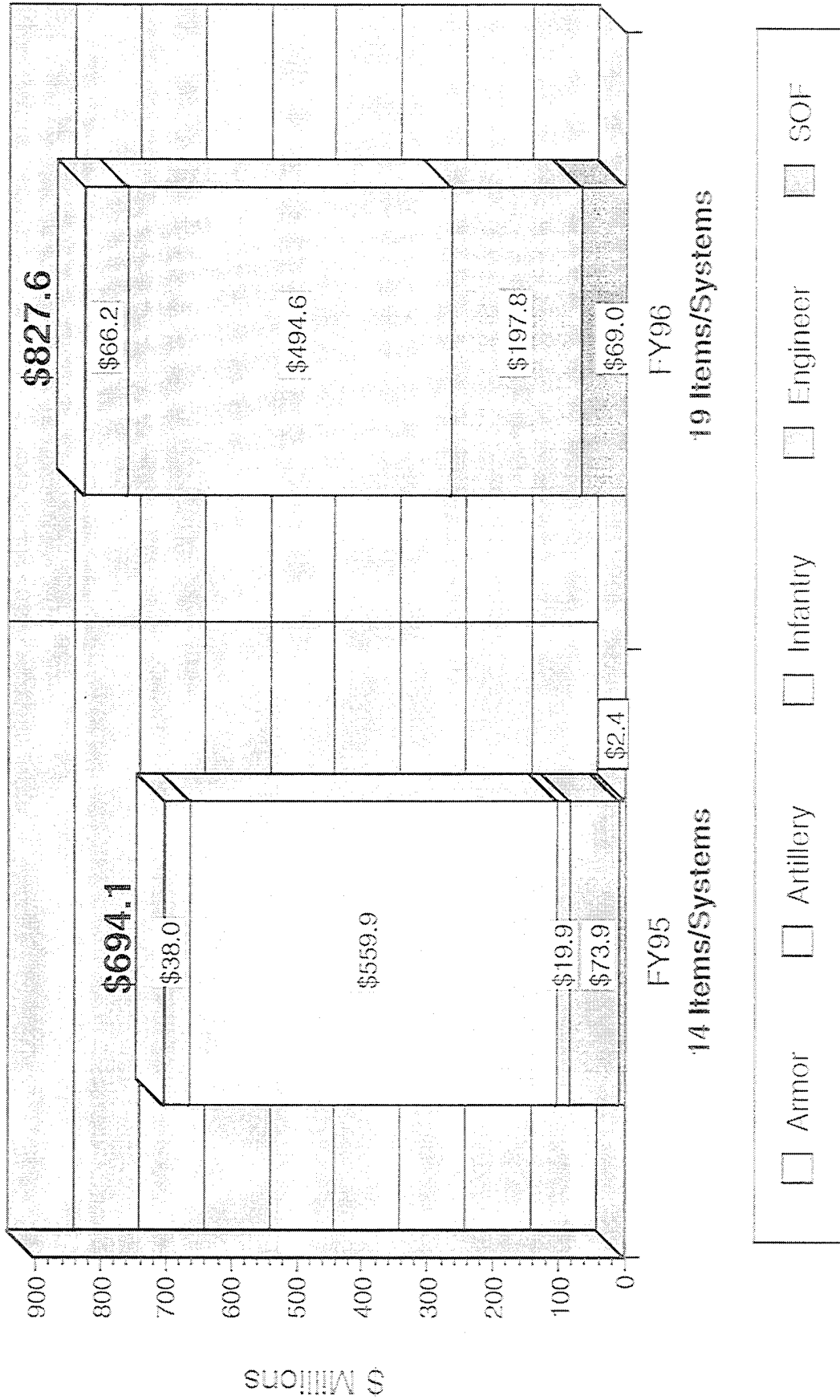

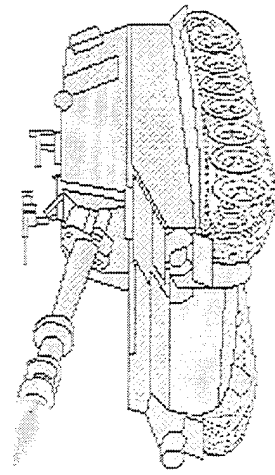

*ARDEC
Technologies*

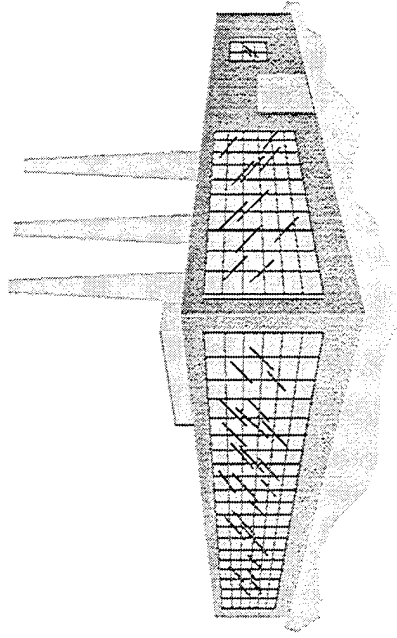
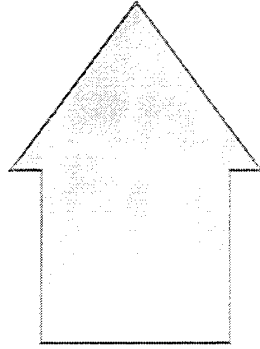

*Industry
Opportunities*

Advanced Planning Briefing For Industry

April 1-3 1996

Mr. Carmine Spinelli
Technical Director

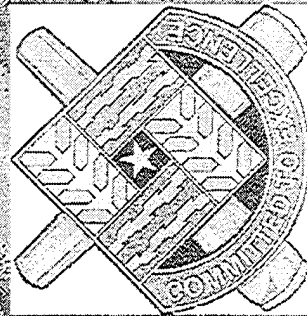

AIRBEC'S MISSION



ARIDTEC'S MISSION

- Strong Technology Base
- Development & Product Improvement
- Production & Fielding
- Life Cycle Engineering Support

Applied Capabilities



Avionics

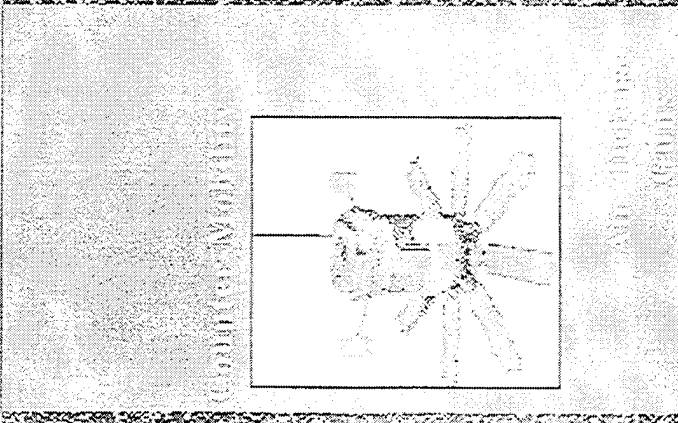
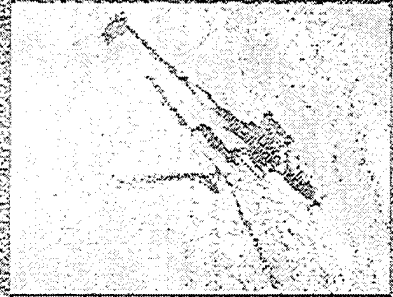

Antennas

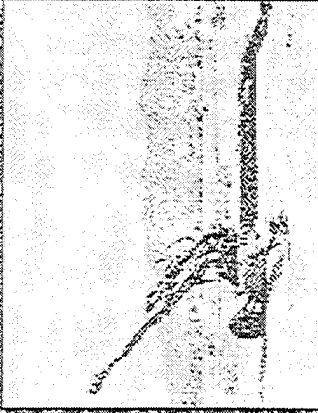

RF-Substrates



Software



RF-Substrates



ARDEC Strategy Development

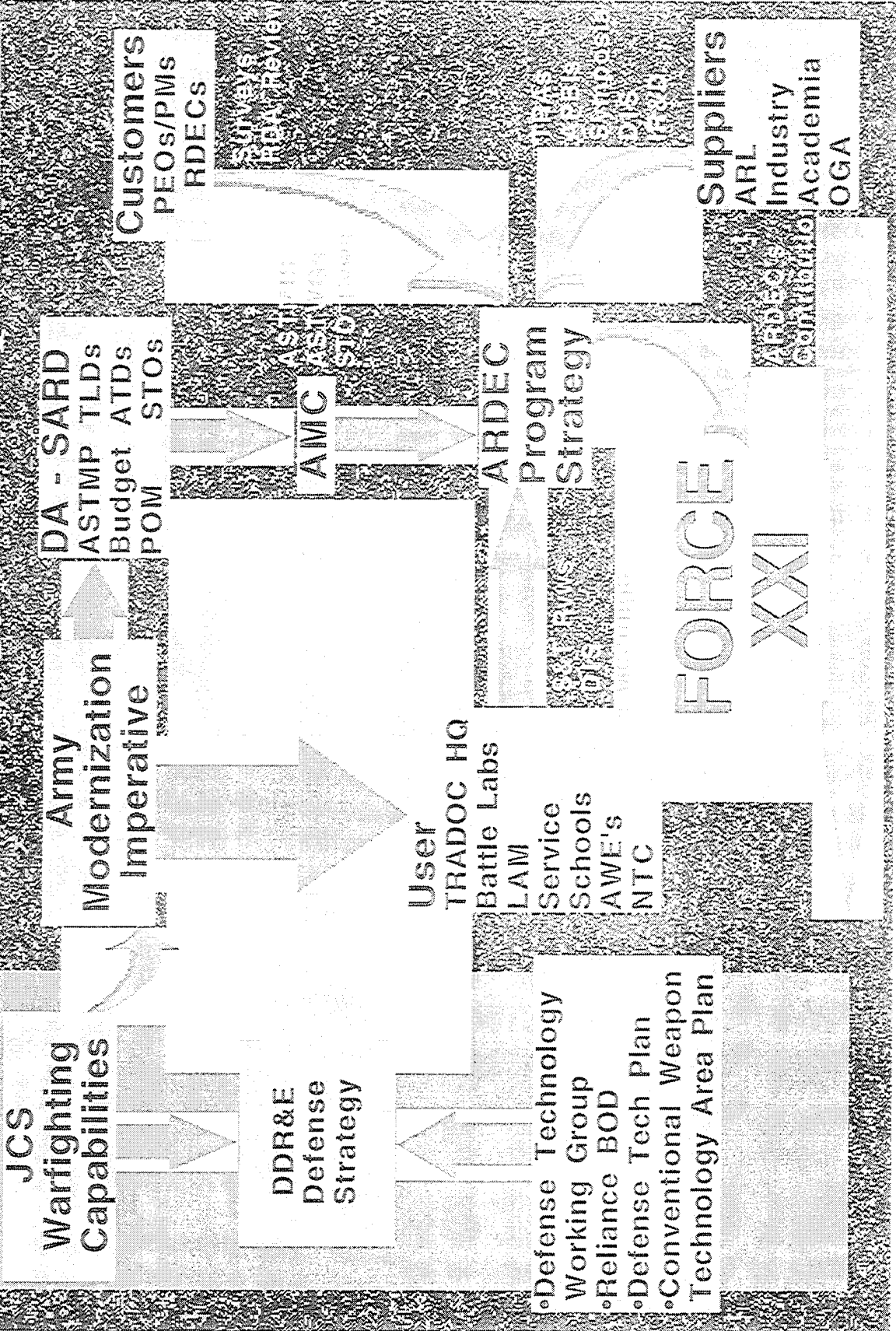

Strategy Development

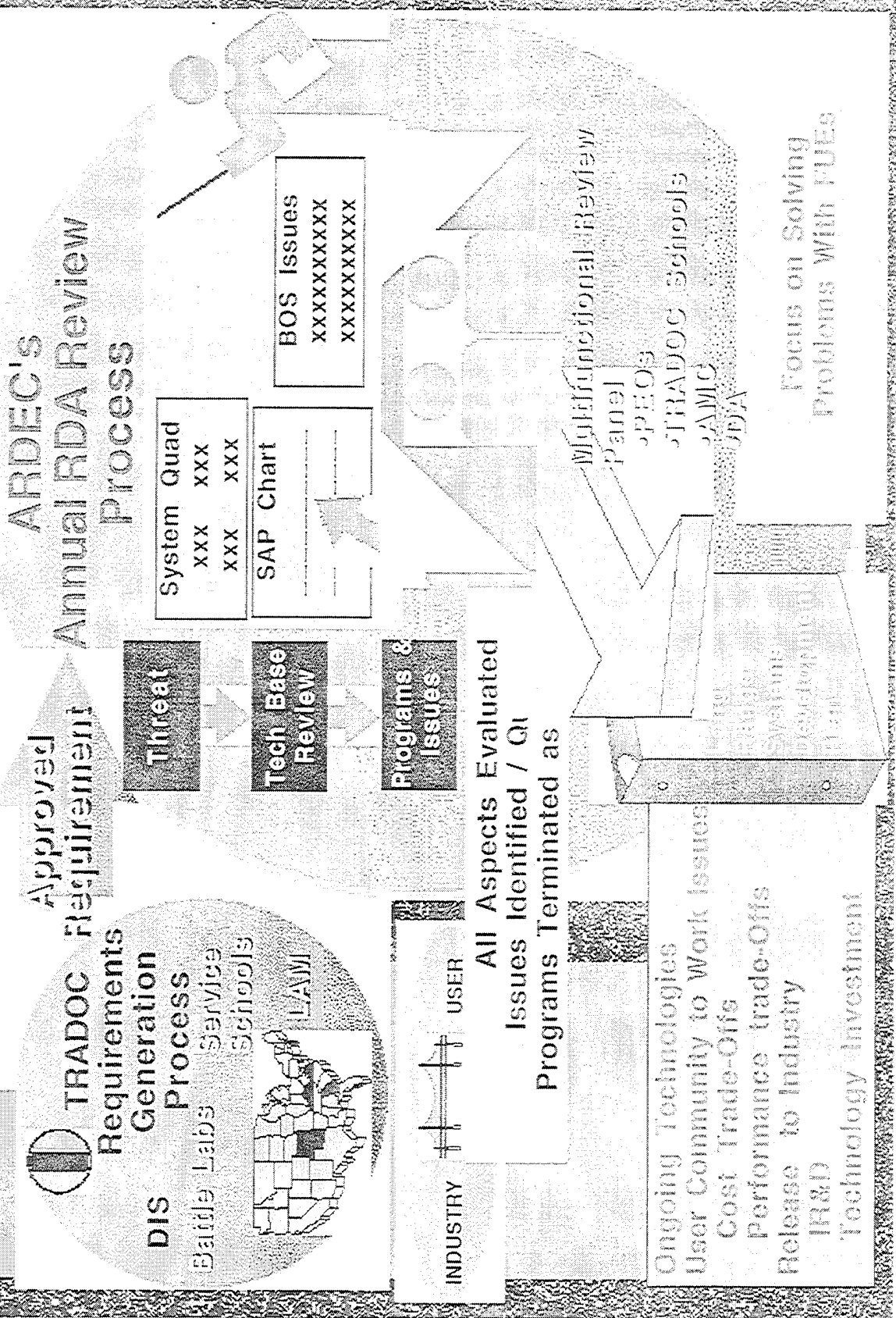

Principles of Accounting



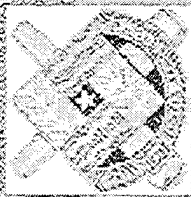

Direct Flight
Availability

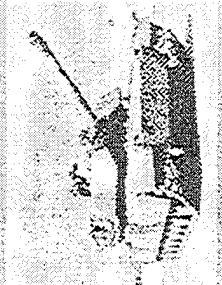

TECHNOLOGY

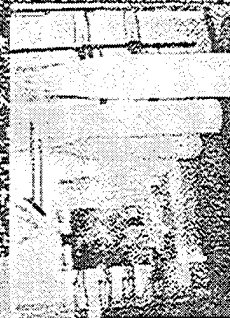

South Pacific's
Super Availability

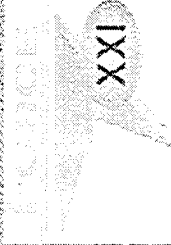

XXI

TRUST AREAS



ARDIFC'S Thrust Areas

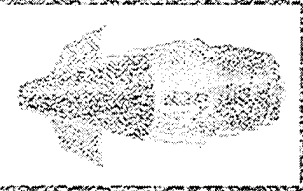

Direct Flight
Availability

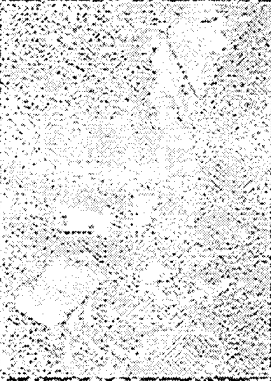
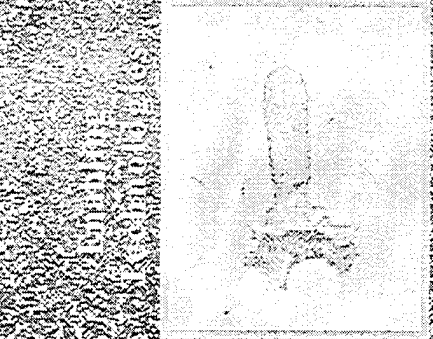

Direct Flight
Availability



ARDIFC

List of ARDIEC Technologists Thrusts and Thrusts Leaders

- Direct Fire
- Indirect Fire
- Rapid Force Projection
- Replic/Digitized Fire Mission
- Sustainment and Survivability
- Innovative Weapons Concepts
- Enabling Technologies
- Environmental

Carl Beaulieu, COAC 5465
Al Wannasch, FSAC 6206
Jeff Dyer, FSAC 4707
Walt Ryba, FSAC 7959
Gary Kent, DALA 2170
Carl Beaulieu, COAC 5466
Ray Blajda, AED 4656
Bob Scola, IEC 2004

All Telephone Numbers Area Code 201 724 XXXX

Revenue Outlook

Total Revenue

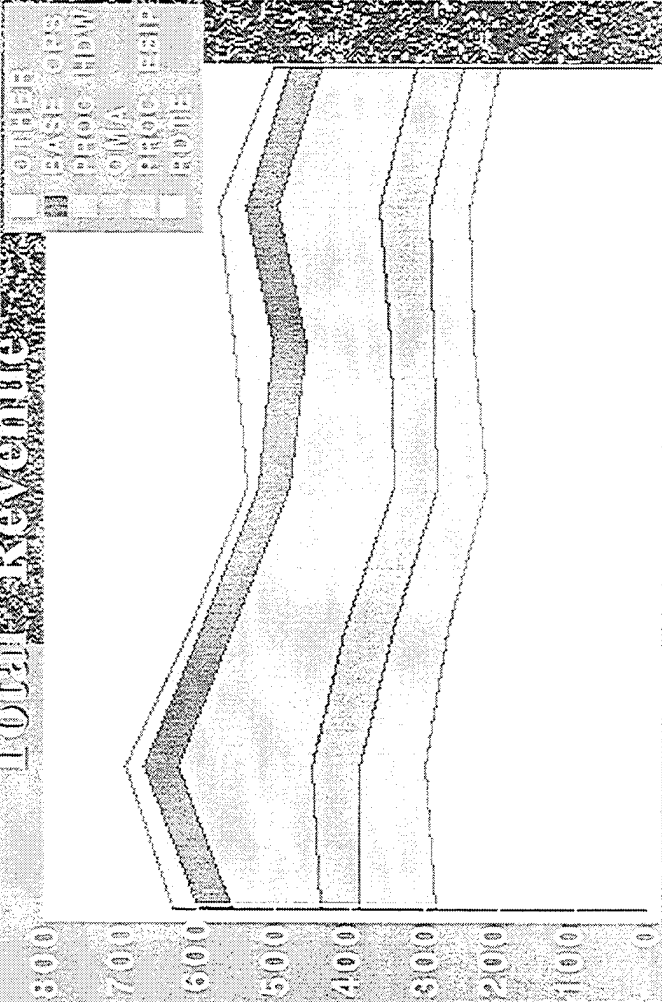

Long Range Funding Impact by Business Area

- Growth Areas
 - Direct Fire
 - Fuze & Lethal Mechanism
 - Munitions Survivability
- Steady State Areas
 - Smart Munitions
 - Soldier Weapons
 - Fire Control
- Slightly Declining
 - Indirect Fire
 - Gun Propulsion

Innovative Weapon Concepts Thrusts Non-Lethal Munitions

Goals

- Weaponize technologies that will collateral damage/non-lethal munition options
- Emphasis on military operations other than war (OOTW)

provide users with low
munition options
other than war (OOTW)

Key Programs

- Low Collateral Damage Munitions
- Non-Lethal Marker Munition (W/ARL, BRDRC) (STO)

User Linkage

- Dismounted Battlespace Battle Lab
- Military/Police
- Special Operations Command
- Early Entry Lethality Survivability
- FBI/Law Enforcement Agencies

Sustainment and Survivability Thrust

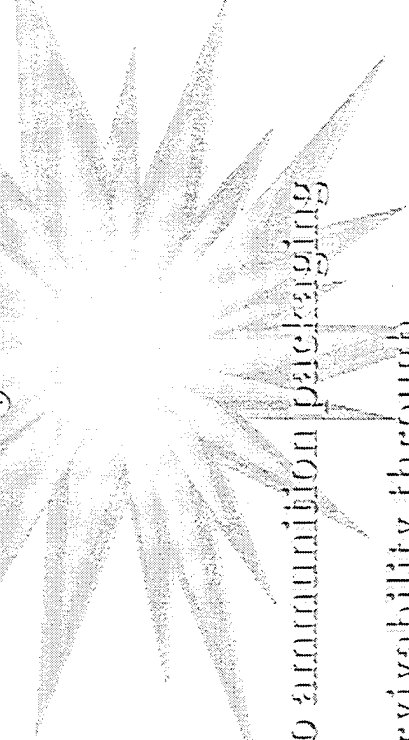

Goals

- Reduce weapon system repair times
- Apply state-of-the-art technologies to ammunition packaging
- Enhance explosive safety
- Improve strategic and battlefield survivability through and other containerization, simulation, MHE, asset tracking and other technologies

Key Programs

- Logistics Survivability (LSO)
- Munitions Survivability Technology (STO)
- Future Munitions Packaging Technology

User Linkage

- Combat Service Support Battle Lab
- Mobile Strike Force
- Advanced Warfighting Experiment
- Aviation and Troop Command

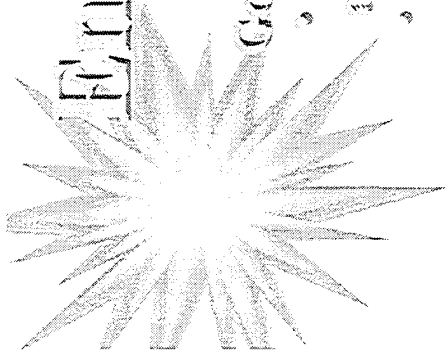

Enabling Technology Thrust



Goals

- Improve Warhead Lethality (25% increase in armor penetration over SADARM type warhead)
- 10% more powerful yet less sensitive energetic materials
- Provide kill mechanism for direct fire lethality program

Key Programs

- Anti-Armor Materials (Joint STO w/ARL)
- Energetic Material and Warheads (STO)
- Warheads for Armor Defeat (STO)
- Polynitroethane Explosives (STO)
- High Energy/High Performance Propellant Formulation for Tank Guns (STO)

User Linkage

- Linked through Armament system thrusts

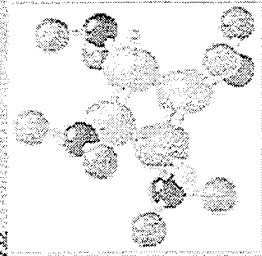
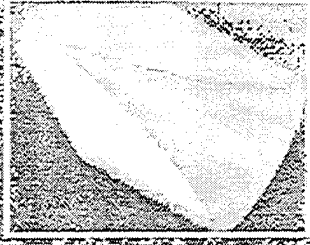

Enabling

- Explosively Formed Penetrators

- Laser Ignition

- Insensitive Munitions & High Performance Explosives

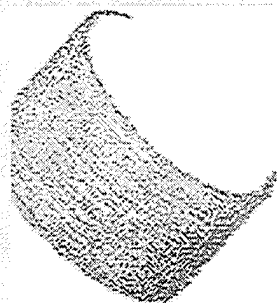
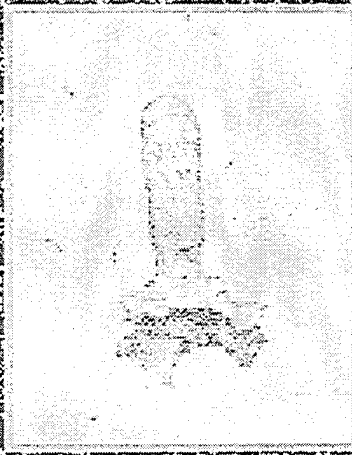

- Used In Major Systems For Top Attack
- ARDEC Recognized As World Leader in EFP Technology

- Achieved A 50% Increase In Armor Penetration

Enabling Technologies

- Explosively Formed Penetrators
- Laser Ignition
- Insensitive Munitions & High Performance Explosives

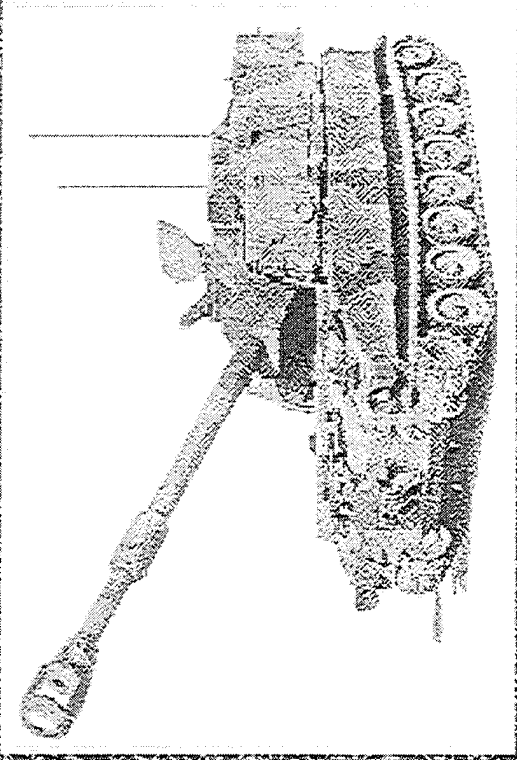

Revolutionary New Approach For Propellant Ignition

• A Complete Laser Ignition System Was Successfully Integrated And Tested In The M109A6 Paladin SP Howitzer

Enabling Technologies

- Explosively Formed Penetrators
- Laser Ignition

• Insensitive Munitions & High Performance Explosives

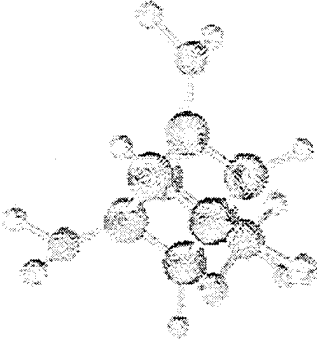

- PAXHA To Be Qualified For 25mm Ammunition
- First Army I/M Explosive

IMI Routes After-Burn



Sig. Routes After-Burn

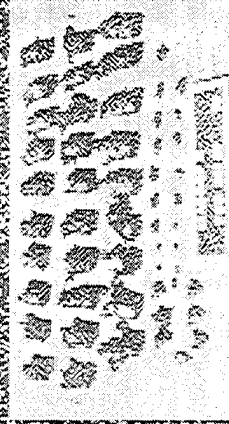

ARDIC Technology for the Future

ARMORY

- ERA Defeat
- Extended Range
- Gun/Ammo Dynamics
- Light Sabot

ADV KE Cartridge
M829A2/A3 &
GUN

- ERA Defeat
- Extended Range

STAFF/
X-ROD

- Increased -Ph
- Crew Safety
- Lower L/C Coats

Adv Turret Drives &
Weapon
Stabilization

- 360 Vision Sight
- Compact A/L

Adv Light
Intelligent
Armament System

- Increase Firepower
- More Kills/Load

Advanced Light
Armament for
Bradley



M1A3



M1A1/2



FMBT

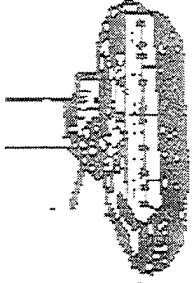

05 06

95 96 97 98 99 00 0

Defeat Of Enemy Armor

Kinetic Energy Technologies

- M829 A2
- XM829 E3
- XM829 E4

Embedded To The Troops

Features:

- Composite Sabor
- Super DU Penetrator
- Kevlar Propellant

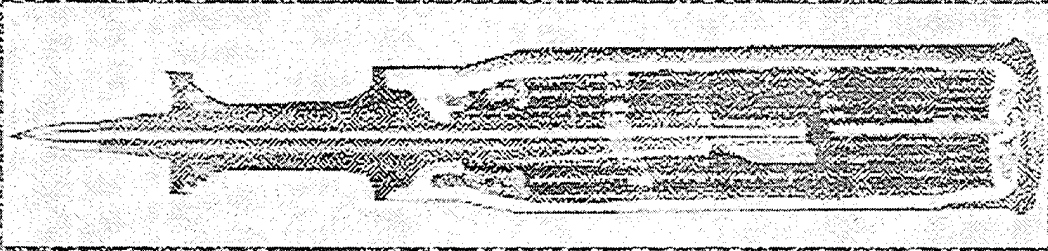

Defeat Of Enemy Armor

• Kinetic Energy Technologies

• M829 A2

• **XM829 E3**

• XM829 E4

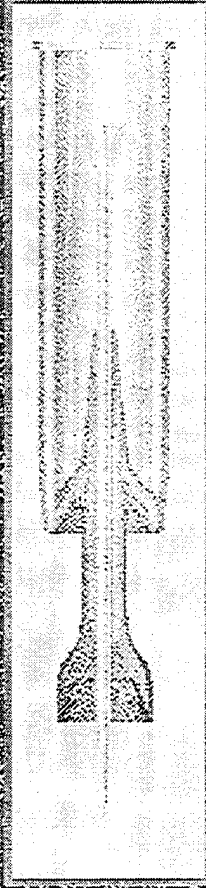

Features:

- High L/D Penetrator
- High Density Propellant
- Greater Velocity & Penetration

Defeat Of Enemy Armor

• Kinetic Energy

• M829 A2

• XM829 E3

• XM829 E4

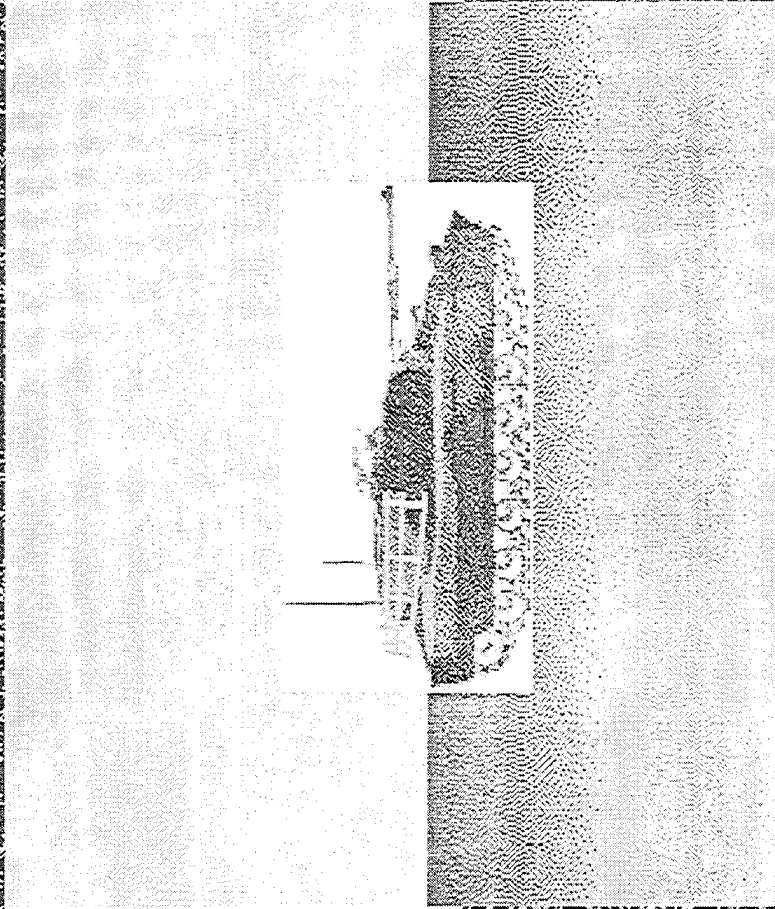

Features:

- Innovative RA Precursor Technology

Defeat Of Enemy Armor

- Smart Systems

- **START**

- X-ROID

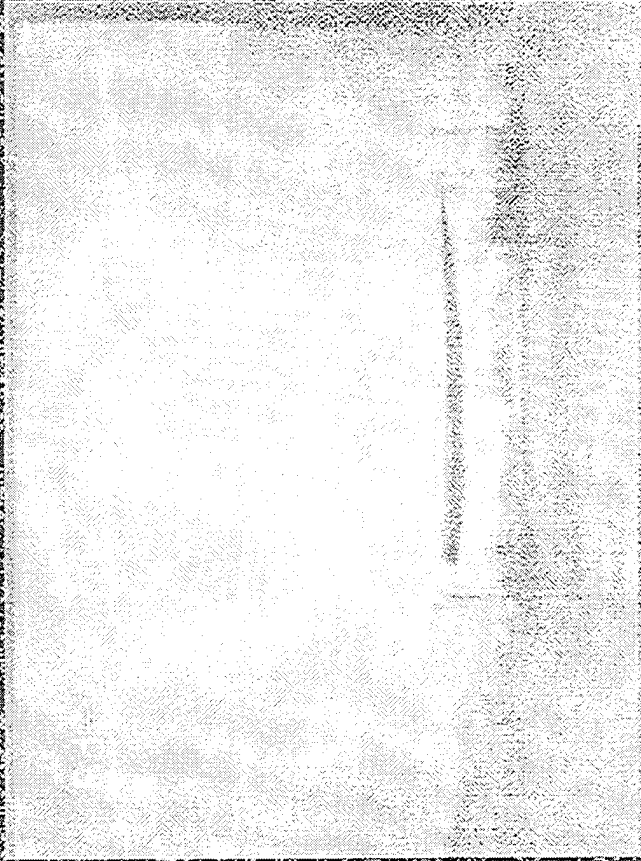
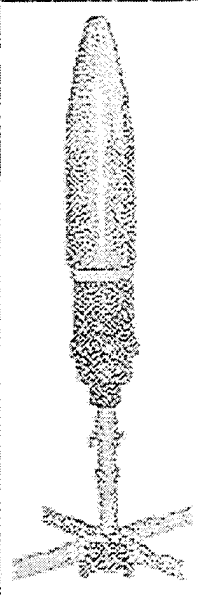

Successfully Completed Both System Integration and Warhead Cover Release Testing in Dynamic Environments

Defeat Of Enemy Armor

- Smart Systems

- STAFF

- X-ROD

RD25

- Demonstrated in Flight Maneuverability
- Successfully Completed Battery And Telemetry Testing



ARDBC Technology for the Future

ARTILLERY

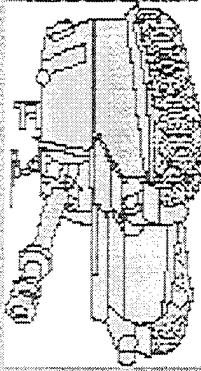

- >50km Range
- >BASEBURN & ROCKET
- >XM80 (35aa)
- >HIGHER PERFORMANCE
- >ROTATING BANDS

PALADIN

XM982

- >IMPR. ACCURACY
- >APPLIED TO STOCKPILE
- >GPS

LCCM

- >155mm
- >FIRE & FORGET
- >TOP ATTACK EFF.

SADARM

- >UN-COOLER IR/LADAR
- >MICRO MOTORS/GPS
- >DIGITIZED FIRE
- >CONTROL

SMART MUNITIONS,
FIRE CONTROL & RAPID
REARM/RESUPPLY

- >ELECTRONIC
- >INCR. RELIABILITY
- >REDUCED DUDS

SELF-DESTRUCT
(SD) FUZE (105mm
and MLRS)

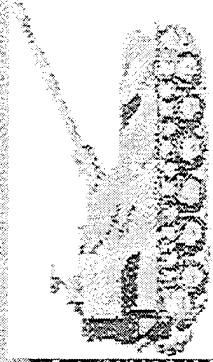

CRUSADER

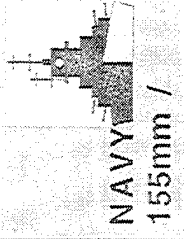
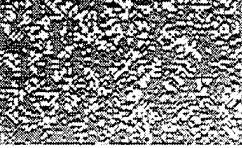

NAVY
155mm /

95 96 97 98 99 00 01 02 03 04 05

Indirect Fire Lethality

• Crusader

• XM982 Extended Range Artillery

• Low Cost Competent Munition

• SADARM

• Self Destruct Fuze

- Increased Survivability, Mobility, Range and Accuracy
- Multiple Round Simultaneous Impact (MRSI) Capability
- Reduced Crew Size (4-3) & Time of Deployment

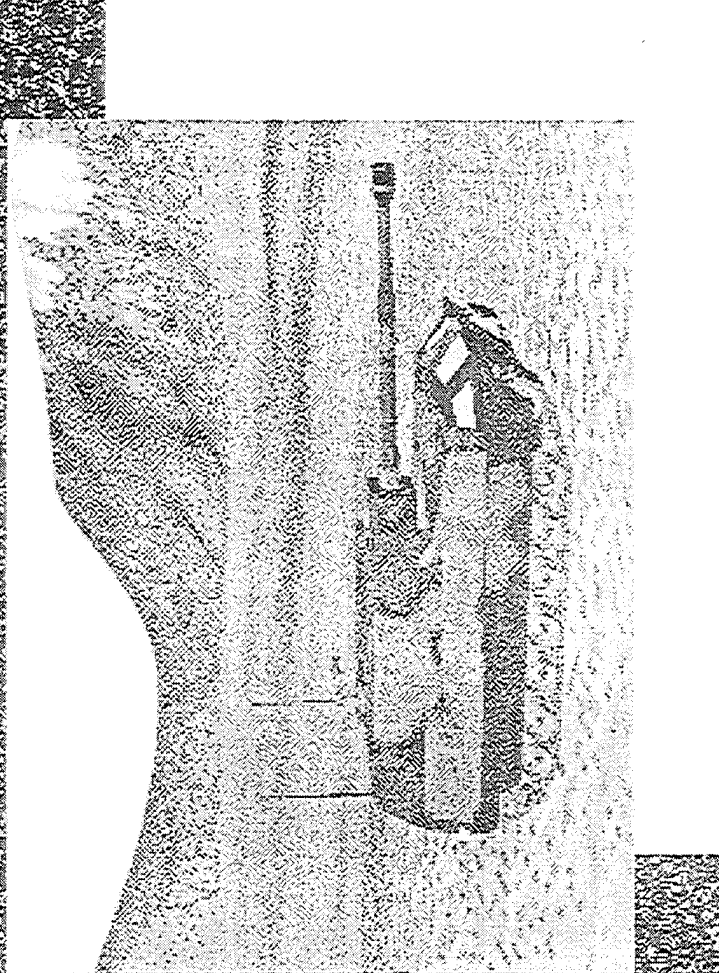

Indirect Fire Lethality

• Crusader

• XM982 Extended Range Artillery

• Low Cost
Competent Munitions

• SADARM

• Self-Destructive Fuze

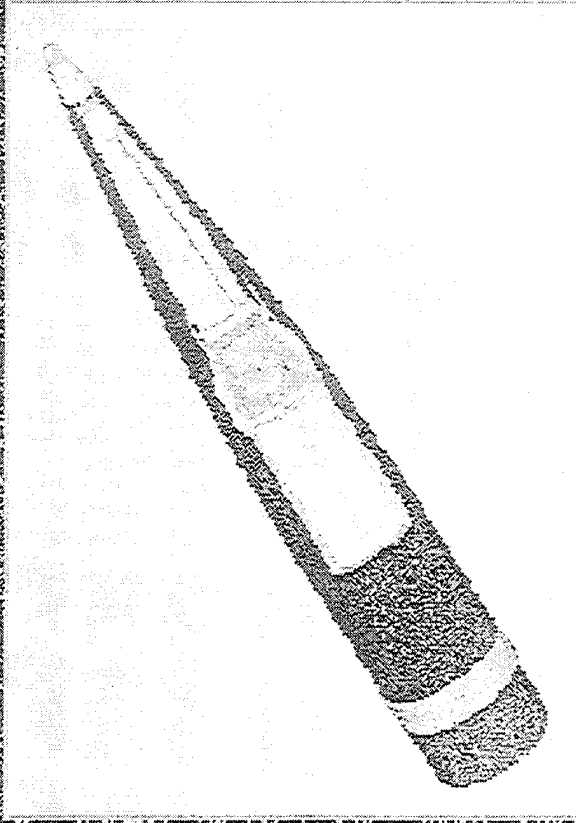

- Successfully Completed Static And Dynamic Flight Testing
- More Than 35% Increase In Range to 50Knm

Indirect Fire Lethality

- Chausader

- XM982 Extended Range Artillery

- Low Cost Competent Munitions

- SADARM

- Self Destruct Fuze

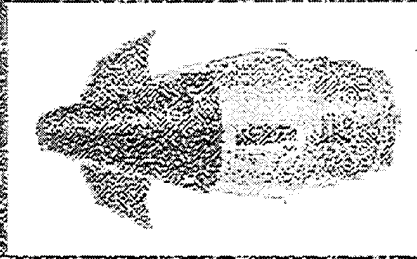
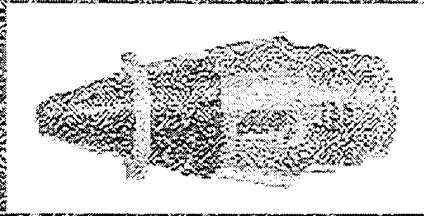
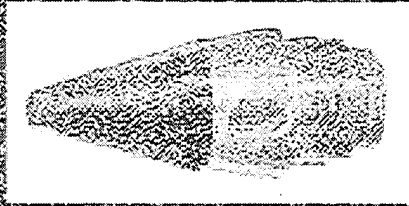

- Completed 2 Proof Of Principle Test Firings Of GPS Aided Registration Modules
- Extrapolated Impact Point To Within 40m Of Actual Impact

Defeat Of Enemy Armor

- Crusader
- XM982 Extended Range Artillery
- Low Cost
- Competent Munitions
- SADARM
- Self Destruct Fuze

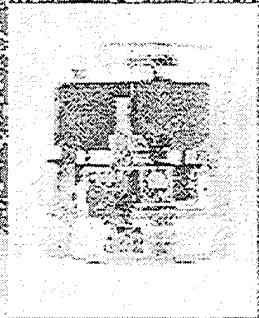
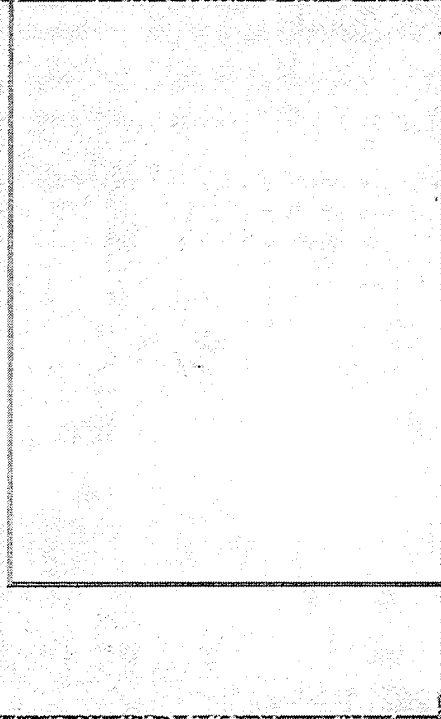
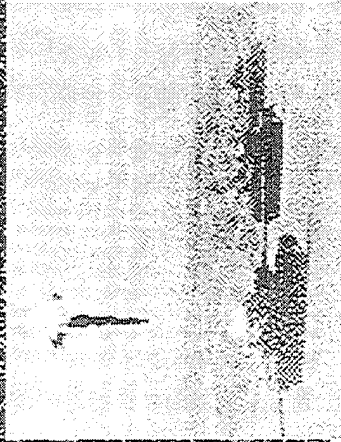

Defeat Of Enemy Armor

• Crusader

• XM982 Extended-Range Artillery

• Low Cost Competent Munitions

• SADARM

• Self-Destructive Fuze

Thirteen Lanyard Pulls
Eleven Targets Hit

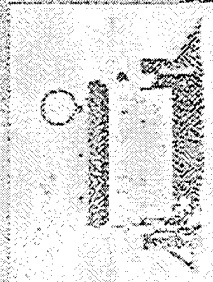
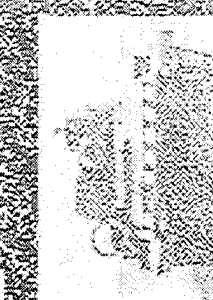
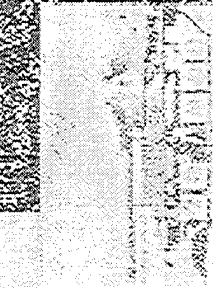
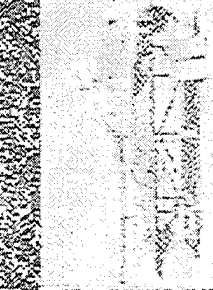
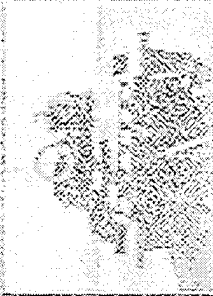
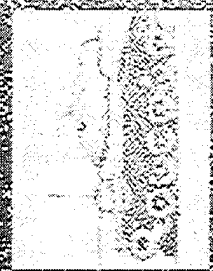
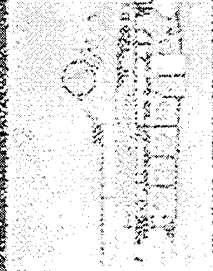
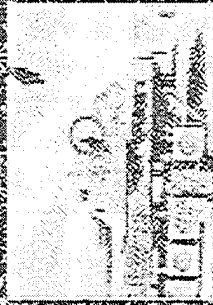
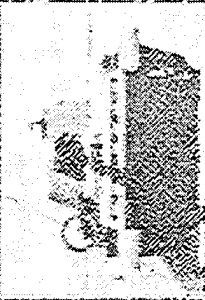
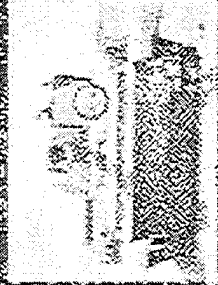

Indirect Fire Lethality

- Crusader
- XM982, Extended Range Artillery
- Low Cost
- Competent Munitions
- SADARM
- Self Destruct Fuze

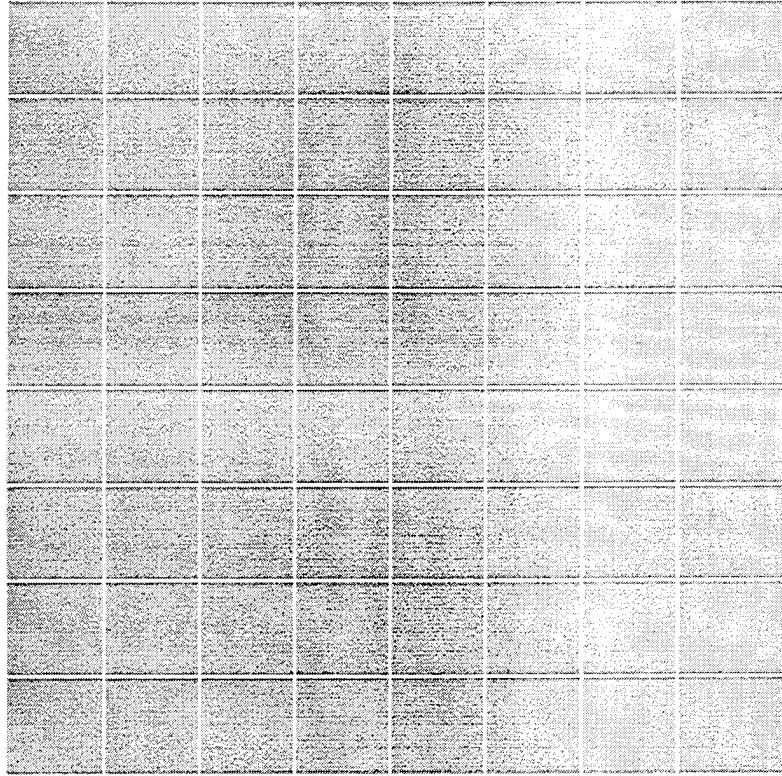
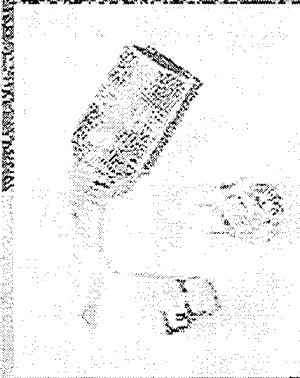

SIX DART MISSILES

Indirect Fire Lethality

- Crusader
- XM982 Extended Range Artillery
- Low Cost Competent Munitions
- SAID/ARM
- Self Destruct Fuze

Six Pack MERS

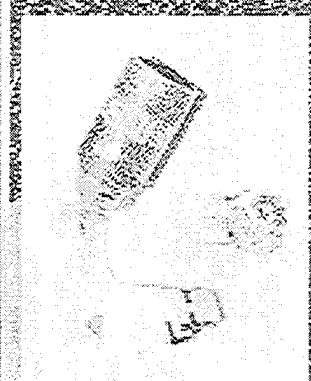
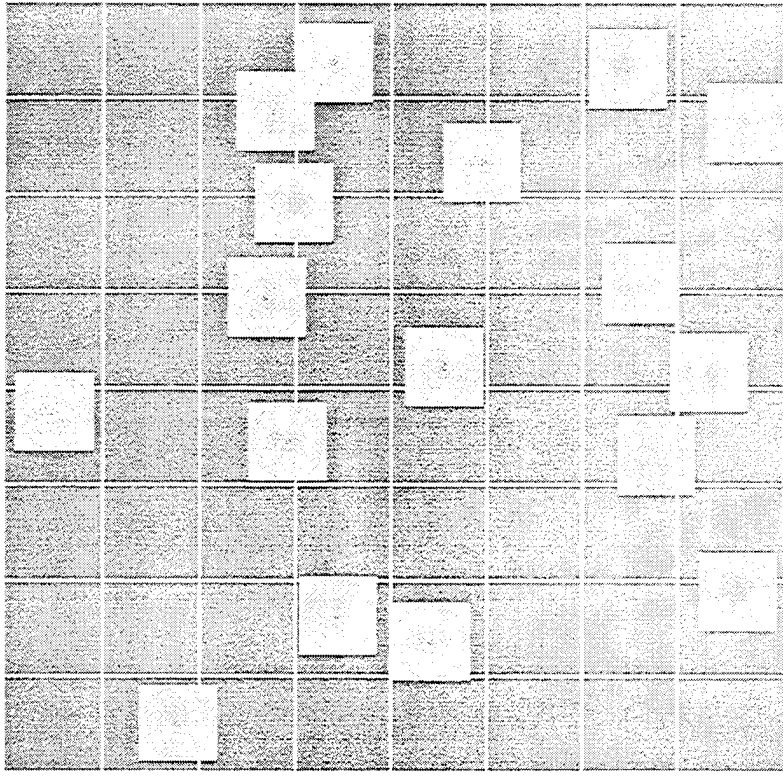

WORLDWIDE PHOTOGRAPHY

Indirect Fire Lethality

- Crusader
- XM982 Extended Range Artillery
- Low Cost Competent Munitions
- SADARM
- Self Destruct Fuze

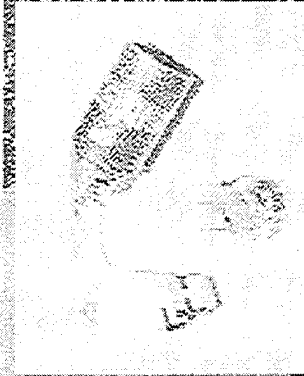

Six Dark Meters

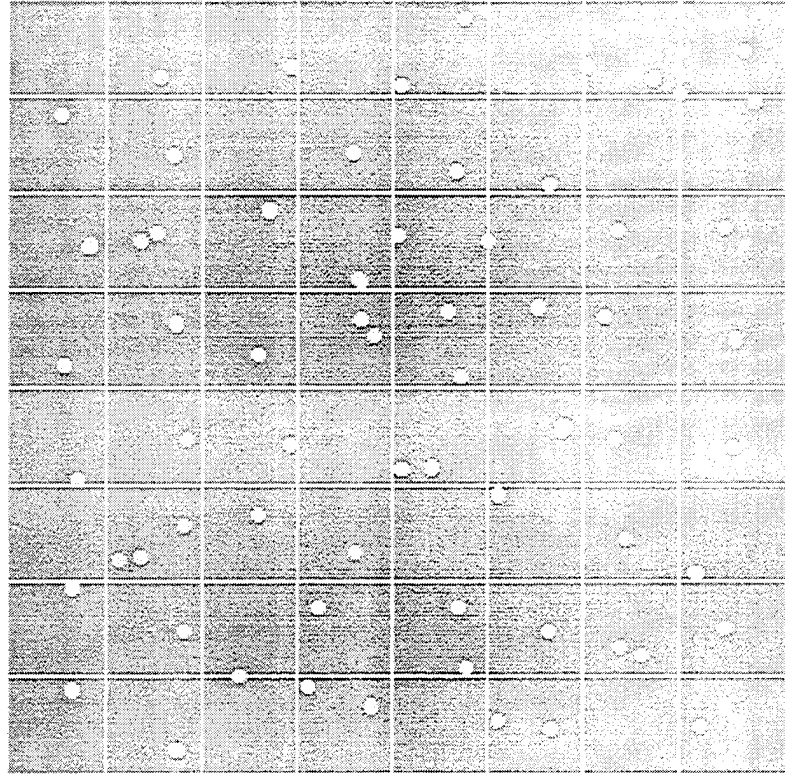

Over 300 Duds on Battlefield

ARDEC Technology for the Future

INFANTRY

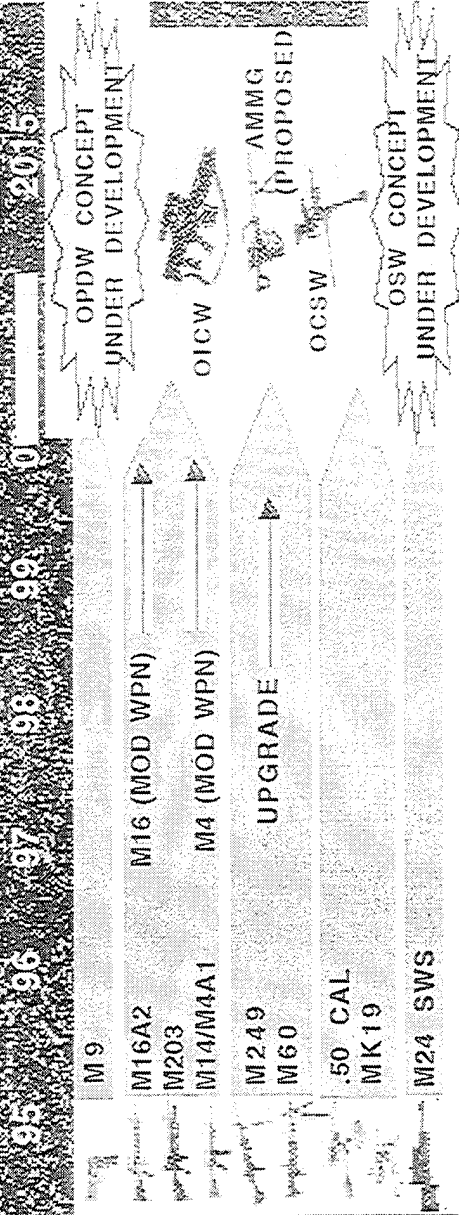

- IMPROVED AMMO
- AP - 5.56, 7.62, .50 Cal
- PRECISION BURSTING
- AGGREGATORS
- OPTICS-DAY/NIGHT
- SCOPES-LASER HARDENED
- MODULAR FIRE CONTROL
- LASER RANGE FINDER
- BALLISTIC COMPUTER
- ADV SUPPRESSION SYS
- MODULAR SYS DEV
- ADAPTORS/BRACKETS

- DIGITIZED FIRE CONTROL
- ON-BOARD BALLISTICS
- ON-BOARD GPS/POS/NAV
- PGMM DEVELOPMENT
- IR/IMVW SENSOR
- LASER DESIGNATOR

FIELDED ENHANCEMENTS

120mm BATTALION MORTAR SYSTEM

MORTAR FIRE CONTROL SYSTEM

120mm PGMM

*EXTENDED RANGE 120mm DPICM MORTAR

*RESPONSE TO CALLS REDUCED FROM 8 TO 3 MIN (TO 1 MIN?)

*AUTONOMOUS & POINT TARGET CAPABILITY

*RANGE OUT TO 12km

*HIGH VALUE TARGET KILLER

*TURRETED MORTAR SYSTEM

*81mm BLAST ATTENUATION (INCR. RANGE)

*60mm & 81mm M.O.FUZE FOR AIRBURST CAPABILITY

*81mm IR ILLUM ROUND

*120mm ROUNDS

60mm, 81mm & 120mm MORTARS

Direct Fire Thrust

- Objective Individual Combat Weapon (OICW)

- Objective Crew Served Weapon (OCSW)

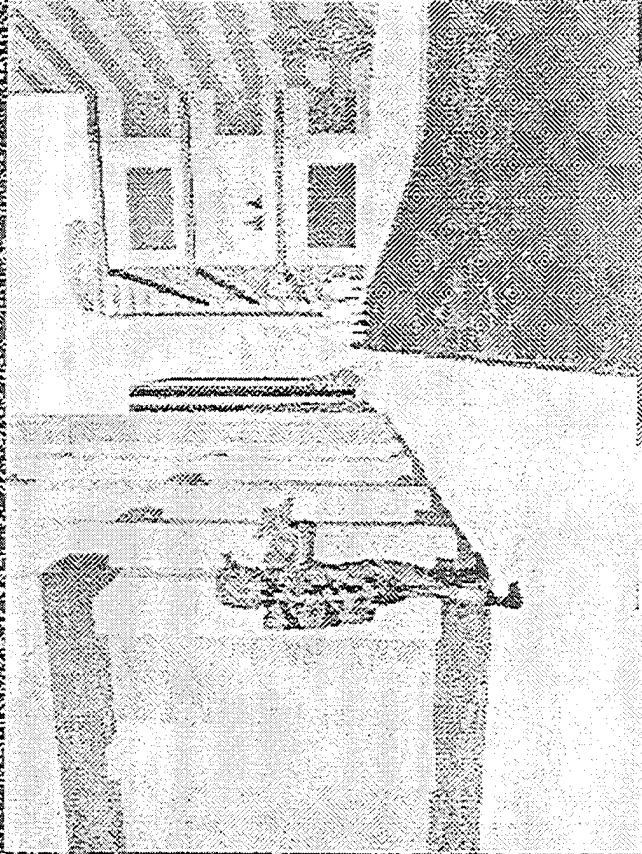

- New Small Advanced Technology Demonstrator (A1D)
- Demonstrated Laser Ranging, Fuze Minimization and Warhead Lethality

Direct Fire Thrust

- Objective Individual Combat Weapon (OICW)

- Objective Crew Served Weapon (OCSW)



- Completed Phase I Competitive Trade Studies
- Phase II's On Course

Infantry (RFPD)

- Precision Guided Mortar Munition (PGMM)



- Demonstrated Live Fire Testing Of Two Foreign Smart Mortars

Rapid Force Projection Initiative

- Intelligent Minefield

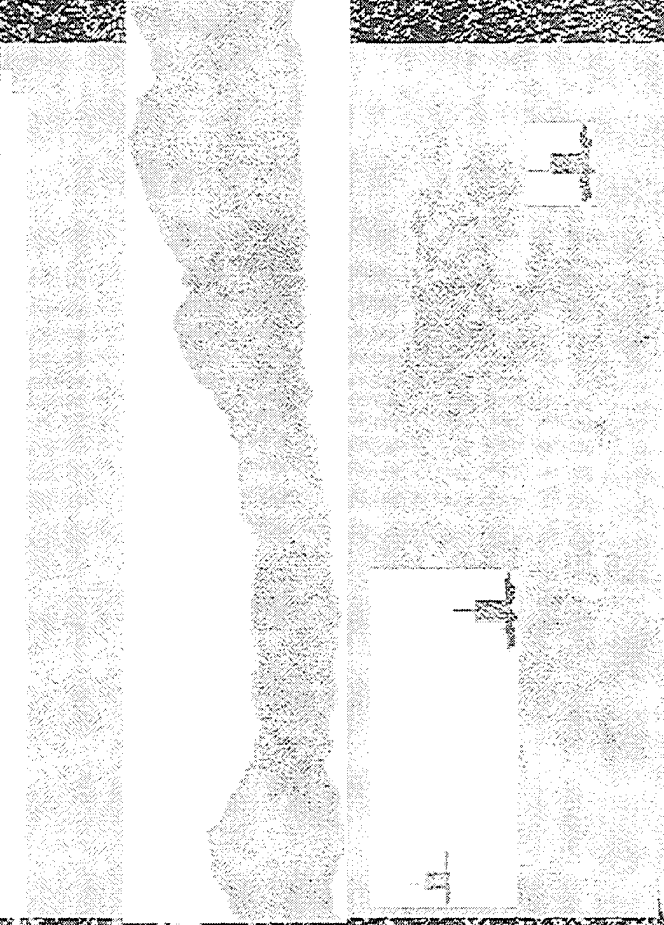

- Demonstrated Operational Effectiveness Of Acoustic Overwatch Sensors

Rapid Force Projection Initiative

- Intelligent Mimetism



- Live Fire Test - Successfully Destroyed A Moving T800 Tank

The Future-Tech Base Programs

ITEMS	EXPECTED YEAR OF TRANSITION
• Objective Individual Combat Weapon*	1999
• Objective Crew Served Weapon*	2001
• XM982, Extended Range Artillery	1998
• Projectile (ERA)*	1998
• Low Cost Competent Munitions*	1998
• Light Weight Automatic	1996/1999
• Howitzer/Advanced Towed Cannon	
• Artillery System*	
• Precision Guided Mortar Munitions*	1998
• Intelligent Minefield (WAM)	1998
• X-ROD*	?

* dependent upon technical success & funding availability

Items Type Classified FY 96 New Opportunities

KEYS	DEVELOPER	FY96 VALUE	6 YEAR VALUE (FY 96-FY 01)
• XM180 Mortar Ballistic Computer	CITE/ITTON COMPUTER	\$5.0	\$18.9
• Wide Area Munition	TEXTRON DEFENSE SYSTEMS	14.6	149.2
• XM19/115/9/16, 1105mm DPICM	CHAMBERLAIN/KDI/AMRON	0	142.3
• M796 1155mm	IOWA/CHAMBERLAIN/THOKOL	55.4	55.4
• M116 Rifle Mod (Optics)	AIMPOINT/TRUION	2.8	12.9

* dependent upon technical success & funding availability

Krems Type Classified RY96

New Opportunities

(CONTINUED)

ITEMS	DEVELOPER	RY96 VALUE	5-YEAR VALUE (FY96-FY00)
XIV929E1 Mortar 120mm (M734E1 Multi Option Fuze (W/XM(M929E1)))	LOCKHEED MARTIN KDI	87.7	147.7
XIV980/983 Ctg. Mortar 120mm Illum/IR Illum	PINE BLUFF/CRANE	0.0	24.0
XIV981 Ctg. Mortar 120mm Full Frange Trainer	POCAL INDUSTRIES	18.8	201.3
XIV816E1 Ctg. 81mm Mortar IR Illum (USMC)	THIokol	49.7	9.5
XIV767 Ctg. Mortar 60mm IR Illum	CRANE/PINE BLUFF	10.6	30.0
M4 Carbine Optics	TBD	9.1	17.9
	TOTAL	\$185.0	\$739.3

Maintain World Class Industrial Base for Equipping Force XXI

- ARDEC Facilities Available For Industry Use:
 - Testing / Laboratories / Instrumentation / Distributed
 - Interactive Simulation (DIS)
- Science and Technology Dollars for Armaments
- Environmental \$27.1M

TRADOC Battlefield Operating System	(\$M) FY97
Fire Support	8616
Maneuver (Mounted)	19019
Maneuver (Dismounted)	8210
(Counter) Mobility	3216
Combat Service Support	2316

64% Available For Contracts

Mounted Operations

Combat Service Support

Mobility/Counter

Fire Support

Dismounted Operations

ARDREC's Strategic Plan For The Future

21st Century Warfare

- Protect the Force
- Execute Precision Strikes
- Win The Information War
- Project & Sustain Combat Power
- Dominate Maneuver

Logistics

- Insensitive Munitions
- Munitions Survivability
- Rapid Repair/Resupply



Armor, Infantry, SOF

- Armor
 - Top Attack Capability
 - Increased PPHit
 - Smart Acquisitions & Gearless drives
- Infantry & SOF
 - Bursting Munitions
 - Selectable Munitions
 - Giro Stable Binoculars



Artillery

- 60% Range Increase
- 400% Rate Of Fire Increase
- 38% Manpower Reduction
- Increased Mobility
- Autonomous



Infantry, Engineers

- Hard Mine Warfare
 - WAM
 - IIMF
- Mortars
 - Balanced Mobility
 - Balanced Fire Control
 - Extended Range
 - Precision Guided

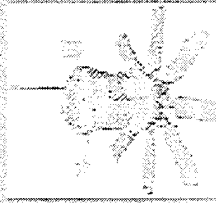
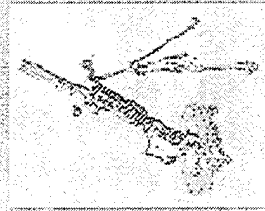

Mr. Carmine Spinelli
ARDEC Technical Director

Phone: Commercial (201) 724-7012/7013
DSIN 830-7012/7013

Mailing Address: US ARMY ARDEC
ATTN: AR-11D, Bldg. 1-4th Fl.
Picatinny Arsenal, NJ
07806-5000

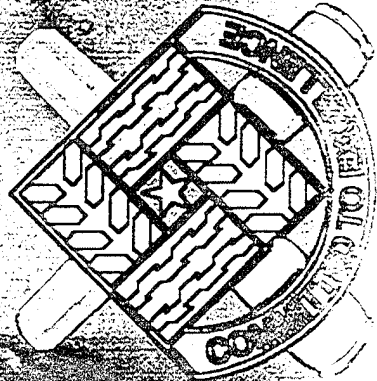

APPROPRIATE CALL

ARDEC 96

Quil

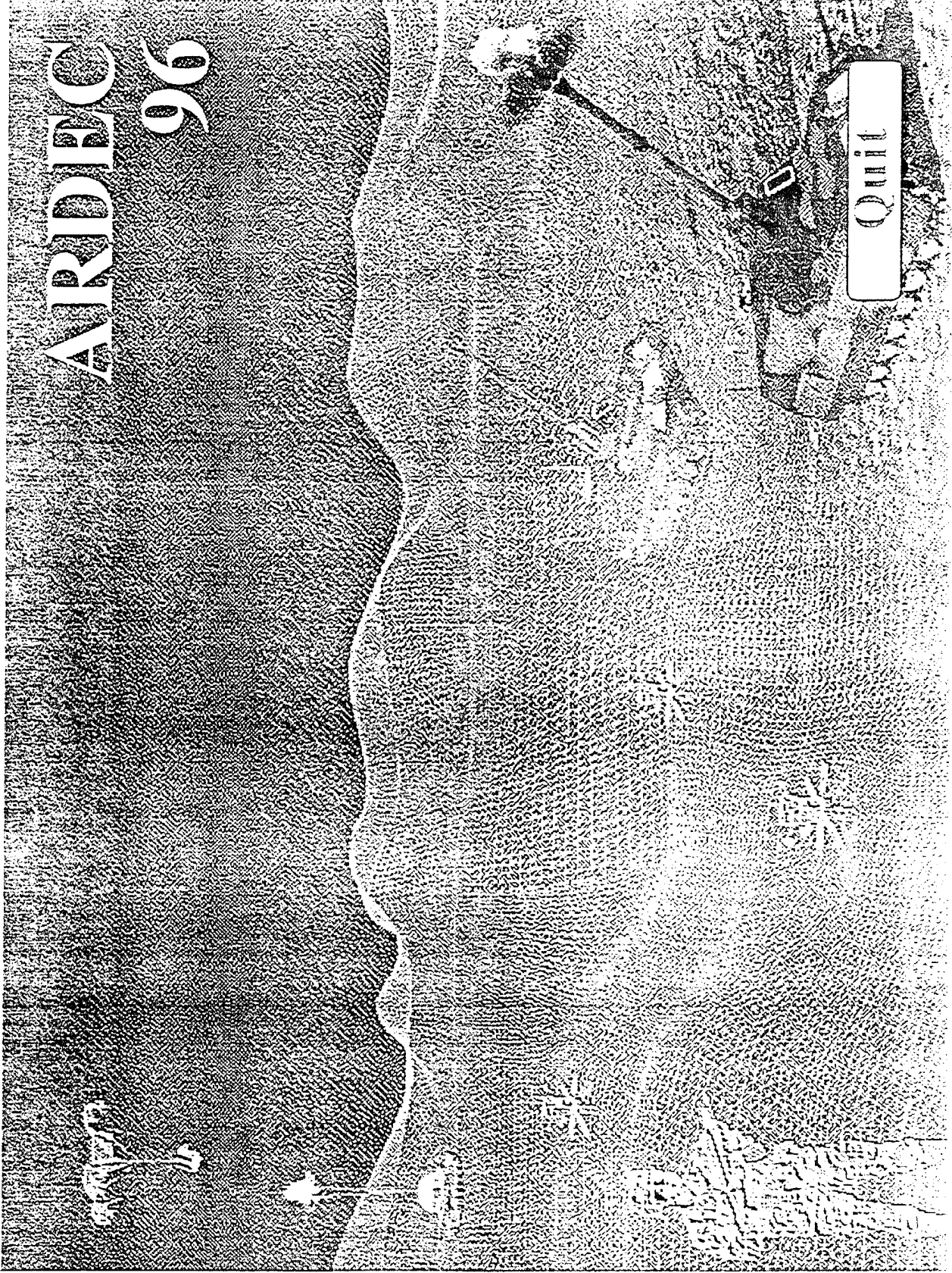

Mr. Carmine Spinelli
ARDEC Technical Director

Phone: Commercial (201) 724-7012/7013
DSN 330-7012/7013

Mailing Address: US ARMY ARDEC
AMSTA-AR-TD, Bldg. 1-4th Fl
Picatinny Arsenal, NJ
07806-5000

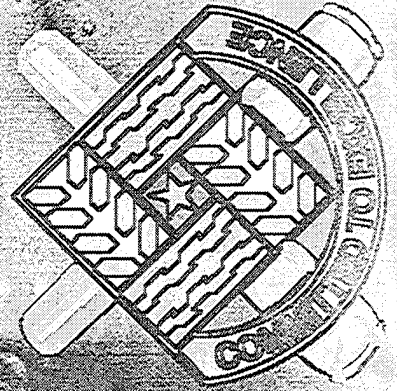

Thank You!

ARDEC

96

Quit

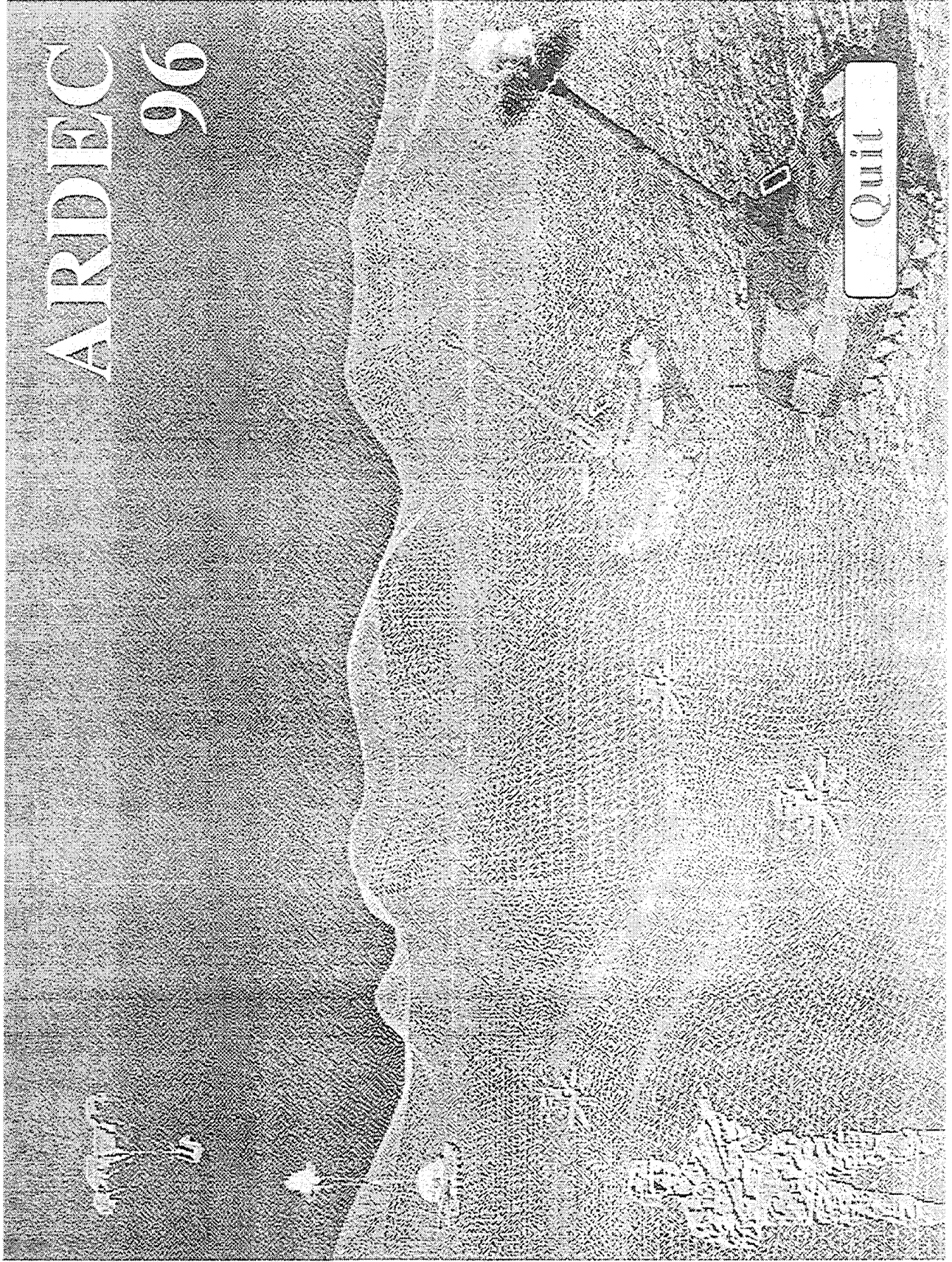

Performance Specifications

IMPACT ON ARMAMENTS ACQUISITION

IOC APBI

1-3 APR. '96

SPENCER HIRSHMAN

TACOMI / ARDEC

ADPA

Dr. Perry Statement

■ " TO MEET FUTURE NEEDS, THE DEPARTMENT OF DEFENSE MUST INCREASE ACCESS TO COMMERCIAL STATE-OF-THE-ART TECHNOLOGY AND MUST FACILITATE THE ADOPTION BY ITS SUPPLIERS OF BUSINESS PROCESSES CHARACTERISTIC OF WORLD CLASS SUPPLIERS.

Dr. Perry Statement (cont.)

■ THE INTEGRATING OF COMMERCIAL AND MILITARY DEVELOPMENT AND MANUFACTURING FACILITATES THE DEVELOPMENT OF DUAL-USE PROCESSES AND PRODUCTS AND CONTRIBUTES TO AN EXPANDED INDUSTRIAL BASE THAT IS CAPABLE OF MEETING DEFENSE NEEDS AT LOWER COSTS."

Performance Spec Defined

- PERFORMANCE SPECIFICATIONS
DEFINE THE FUNCTIONAL
REQUIREMENTS FOR AN ITEM, THE
ENVIRONMENT IN WHICH IT MUST
OPERATE, AND ALL INTERFACE
AND INTERCHANGE
CHARACTERISTICS

Performance Specification Definition (Cont.)

- **A COMPILATION OF ALL QUANTIFIABLE CHARACTERISTICS WHICH DEFINE WEAPONS/MATERIEL SYSTEM FUNCTIONAL REQUIREMENTS [E.G. FORM, FIT, FUNCTION, PERFORMANCE, AND INTERFACES]. IT STATES ITS REQUIREMENTS IN TERMS OF THE REQUIRED RESULTS WITH CRITERIA FOR VERIFYING COMPLIANCE, BUT WITHOUT STATING THE METHODS FOR ACHIEVING THE REQUIRED RESULT**

How Is Performance Spec. Policy Being Implemented?

- DoD
ALL ACAT programs for new systems, major modifications, technology generation changes, nondevelopmental and commercial items
- NAVY & AIRFORCE
 - In Compliance with DoD Policy
- ARMY
 - ALL Solicitations(jaw applicable MAP)
including non ACAT programs, services, rebuys of ACAT systems, replenishments &

Ammunition Performance Specification Considerations

- [1] Safety hazard, less than 1 chance per 1,000,000 opportunities
- [2] Interoperability-NATO, inter service, inter weapon system operational behavior [examples are: ballistics which are consistent with fire control computers; communication protocols; RSI agreements]
- [3] Shelf life and Demil- for items which DoD will eventually bear the responsibility of inventory maintenance and end- of- useful- life disposition
- [4] EOD - explosive ordnance disposal

Implications of Performance Specifications on Acquisition

- Use of performance specifications in procurement, replenishments, procurement of Spares
 - SUPPORTS LONG TERM PARTNERING RELATIONSHIPS
 - SOLE SOURCE PROCUREMENTS
 - REDUCES GOV'T INVOLVEMENT IN CONFIGURATION CONTROL
 - FUNCTIONAL AND PERFORMANCE LEVEL REQUIREMENTS ONLY

Performance Spec Environment

■ GOVERNMENT TDP

- UPDATE AND CERTIFY FOR PROCUREMENT*
- PROVIDE TO OFFERORS AS ADVISORY
- OFFER HARDWARE SAMPLES FOR TEARDOWN / EVALUATION

■ CONTRACTOR TDP

- CONTRACTOR REQUIRED TO BASELINE A TDP OF HIS CHOICE FOR PRODUCTION
 - MUST SATISFY PERFORMANCE REQUIREMENTS AND INTERFACE STANDARDS
 - MUST MAINTAIN TDP
 - MUST PROVIDE CONFIGURATION MANAGEMENT
- BASELINE TDP AUDITED PRIOR TO FIRST ARTICLE TESTING
- GOV'T. USES TDP TO SATISFY PRODUCT OWNERSHIP NEEDS AND MAY USE AS ADVISORY PACKAGE FOR FUTURE BUYS WITH APPROPRIATE LICENSE

*MIL SPEC REFERENCES NEED NOT BE PURGED FROM TDP AS THEY ARE ADVISORY

THE ROLE OF DRAWINGS

- PERFORMANCE SPECIFICATIONS DEFINE CUSTOMER REQUIREMENTS
- DRAWINGS DEFINE PRODUCTS, SYSTEMS AND THE SUPPORTING INFRASTRUCTURE
- DRAWINGS MUST BE CREATED AND MAINTAINED TO CONTROL AND DOCUMENT THE LIFE CYCLE OF MATERIEL
- THEY ARE A NECESSARY EXPENSE TO PROGRAMS
- HOWEVER, OWNERSHIP AND MAINTENANCE WILL VARY BY THE PRODUCT AND CIRCUMSTANCES

THE ROLE OF DRAWINGS

- DRAWINGS ARE REQUIRED TO PROVIDE;
 - A FOUNDATION FOR STANDARDIZATION
 - DOCUMENTATION AND VALIDATION OF DESIGN AND ENGINEERING
 - INFORMATION TO DESIGNERS AND MANUFACTURERS
 - CONTROL OF PROTOTYPES, PRODUCTION AND MAINTENANCE
 - BASIS FOR SIGNATURES TO AUTOMATED EQUIPMENT AND PROCESSES
 - CONTROL OF INTERFACES BEYOND THE CAPABILITY OF WRITTEN STANDARDS
- DOCUMENTED CONFIGURATION HISTORY OF PRODUCT
- FACTUAL INFORMATION FOR ANALYSES, STUDIES AND INVESTIGATION
- LEGAL SAFE GUARDS
- INDUSTRIAL PREPAREDNESS
- DEMILITARIZATION/DISPOSAL

THE ROLE OF DRAWINGS

- INDUSTRY USES DRAWINGS WITH PERFORMANCE SPECIFICATIONS

JOHN DEERE

- "WE ARE USING PERFORMANCE SPECIFICATIONS TO BUY NEW SUBSYSTEMS"
- "WE OBTAIN THE DRAWINGS IF POSSIBLE" FOR SPARE PARTS MANUFACTURE

SEARS

- MOST PRODUCTS ARE BOUGHT TO PERFORMANCE SPECIFICATIONS BUT IF THEY'RE BUYING SHOES FROM A DEVELOPING COUNTRY THEY APPROVE THE PRODUCT AND THE PRODUCTION PROCESSES, "A SHOE MUST LOOK AND PERFORM LIKE A SHOE."
- SAFETY REQUIREMENTS ARE VERIFIED IN INDEPENDENT LABORATORIES

THE ROLE OF DRAWINGS

■ SEARS (CONT'D)

- DRAWINGS ARE GENERALLY RETAINED BY SUPPLIERS
BUT SPARE PARTS ARE REVERSE
ENGINEERED/RE-ENGINEERED BY SEARS TO REDUCE

COST

- GOVERNMENT MUST HAVE ACCESS TO DRAWINGS /
OTHER TECHNICAL DATA DEVELOPED AT CONTRACTOR
EXPENSE UNDER PERFORMANCE SPECIFICATIONS TO
SATISFY:

- OWNERSHIP NEEDS DURING LIFE OF PRODUCT
- STANDARDIZATION
- INDUSTRIAL PREPAREDNESS
- NATIONAL SECURITY NEEDS

THE ROLE OF DRAWINGS

- RECOMMEND CONTRACTS PROVIDE FOR
 - ROYALTY FREE USE OF DRAWINGS / TECHNICAL DATA TO SATISFY OWNERSHIP NEEDS FROM DESIGN ASSESSMENTS TO DEMILITARIZATION
 - ROYALTY FREE USE OF DRAWINGS / TECHNICAL DATA FOR ACQUISITION IN AN EMERGENCY OR IF CONTRACTOR IS INCAPABLE OF MEETING GOVERNMENT NEEDS
 - LIMIT LIFE OF CONTRACTOR PROPRIETARY RIGHTS - SAY FIVE YEARS OR CURRENT STATUTORY LIMIT FOR SPARE PARTS
 - OPTION TO BUY OR LICENSE DRAWINGS/TECHNICAL DATA FOR GENERAL NEEDS OF GOVERNMENT

Draft Performance Spec. Hardware Acceptance Provisions

- Available on the Internet

- ARDEC STANDARDIZATION BRANCH

- <http://www.pica.army.mil/orgs/edmd/edd/sb/top.html>

- Draft Performance Spec. Quality Assurance Provisions

Advanced Planning for Industry

PM Mortars Overview

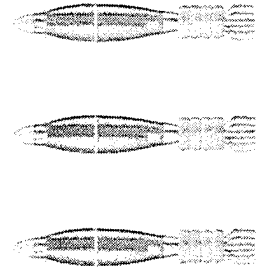
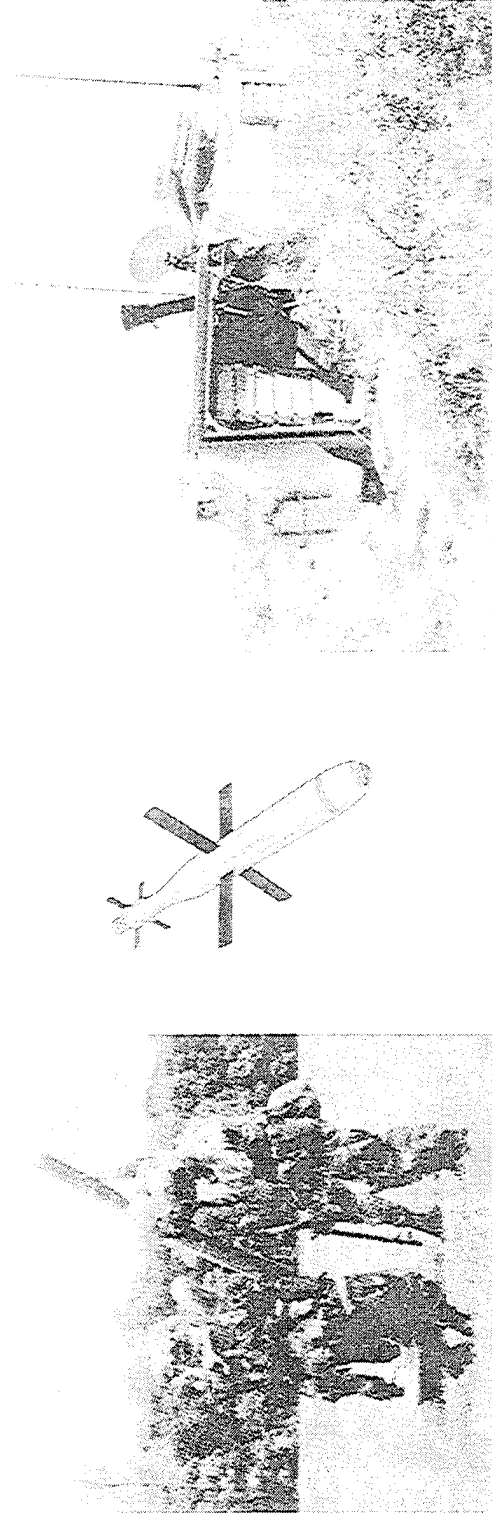









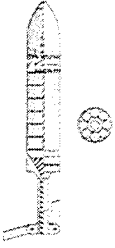
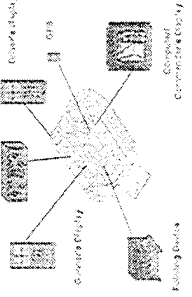







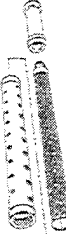

LTC Steve Davis
PM Mortars

PM Mortars Charter

*Manage development, test, qualification,
initial production and fielding of new mortar
weapon ammunition and fire control systems
for US DoD customers*

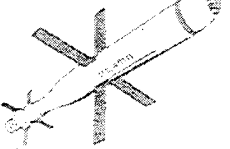
MORTARS SPANS THE ACQUISITION SPECTRUM

CONCEPT	DEMONSTRATION	DEVELOPMENT	PRODUCTION & FIELDING	MODS
 <p>Lightweight Composite 120mm DPICM Multi-Spectral Smoke Non-Lethal Warheads</p>	 <p>MORTAR FIRE CONTROL SYSTEM</p>	 <p>M30, IMBC</p>  <p>120mm ILLUM</p>  <p>120mm IR ILLUM</p>  <p>120mm FULL RANGE TRAINING CARTRIDGE</p>	 <p>M121</p>  <p>120mm HE/PD-MO</p>  <p>120mm SMOKE</p>  <p>81mm HE/PD-MO</p>  <p>60mm SHORT RANGE TRAINING ROUND</p>  <p>M303 INSERT</p>  <p>M67 SIGHT UNIT</p>	 <p>81mm IR ILLUM</p>  <p>60mm IR ILLUM</p>  <p>M734E1 MULTI-OPTION FUZE</p>
 <p>TURRETED MORTAR SYSTEM (TMS)</p>	 <p>PRECISION GUIDED MORTAR MUNITION (PGMM)</p>  <p>UNIVERSAL FUZE FCT</p>			

PM Mortars Prime & Major Contractors

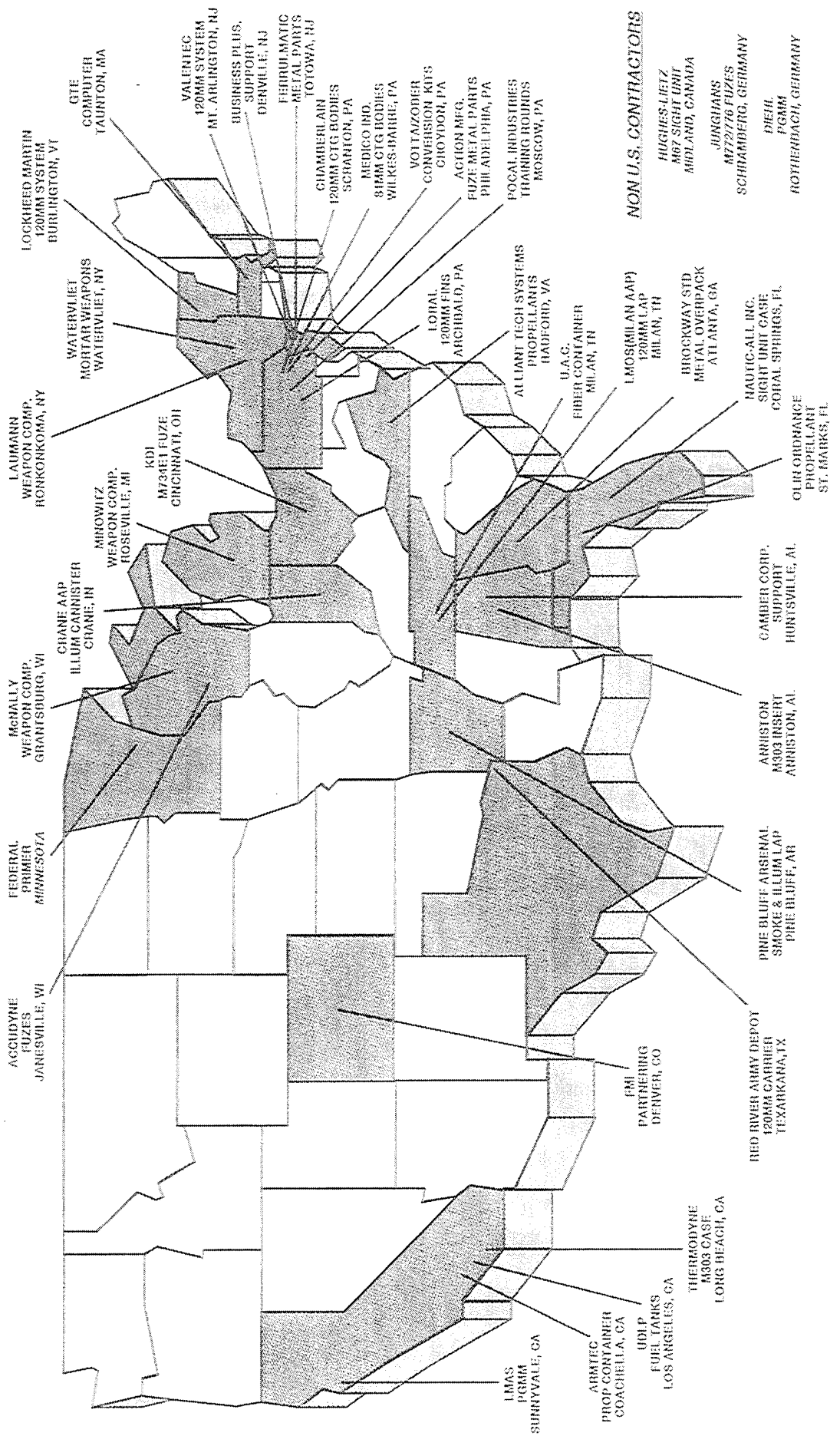

NON U.S. CONTRACTORS

- HUGHES-LEITZ M67 SIGHT UNIT MIDLAND, CANADA
- JUNGHANS M72/276 FUZES SCHRAMBERG, GERMANY
- PIEHL FGMM ROTTERDAM, GERMANY

Total Program Funding Available

BY APPROPRIATION

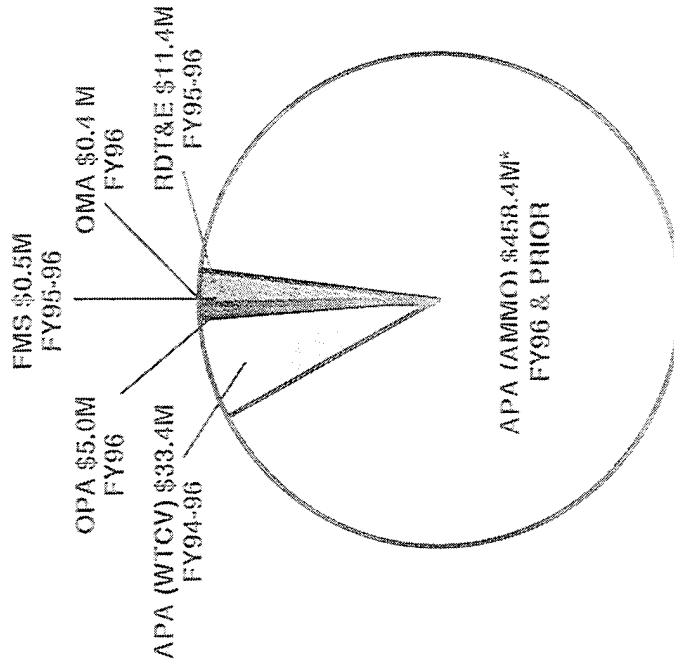

BY CUSTOMER

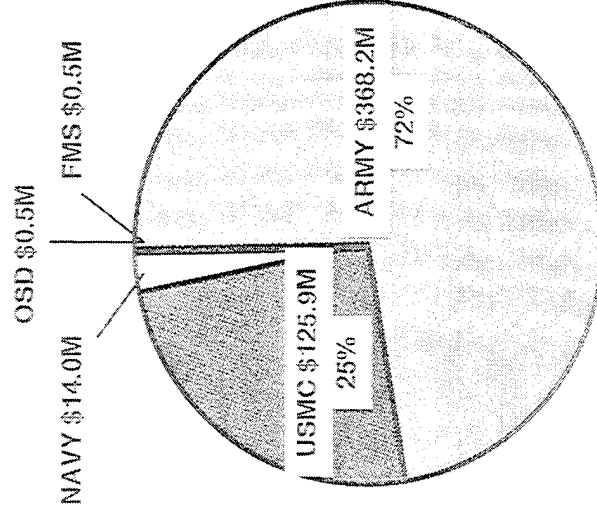

TOTAL \$509.1M

\$219.7M Unexpired/Undelivered Ammo Prior to FY94

AS OF 29-FEB-96

OPPORTUNITIES FOR INDUSTRY

120MM PRODUCTION

<u>ITEM DESCRIPTION</u>	<u>APPROX \$M</u>	<u>COMP/NON-COMP</u>	<u>ISSUE</u>	<u>EST AWARD</u>
120mm Cartridge Bodies (FY96-00)	\$ 11.3M (96)	NC - Chamberlain	3QFY96	4QFY96
120mm Increment Containers (FY96-00)	\$ 1.6M (96)	NC - Armtec	3QFY96	4QFY96
120mm Fin Assemblies (FY96-00)	\$ 3.1M (96)	Limited Comp.*	3QFY96	4QFY96
120mm Ignition Cartridge/ Ignition Cartridge LAP (FY96-00)	\$ 1.2M (96)	Limited Comp.*	3QFY96	4QFY96
120mm Propelling Charge (FY96-00)	\$.5M (96)	Limited Comp.*	3QFY96	4QFY96
PA153 Fiber Containers (FY96-98)	\$.7M (96)	Limited Comp.*	3QFY96	4QFY96
PA154 Fiber Containers (FY96-98)	\$ 1.2M (96)	Limited Comp.*	3QFY96	4QFY96
M734E1 Fuze (FY96-97)	\$ 13.0M (96)	NC-KDI	3QFY96	4QFY96
M931 Full Range Training Round (FY96)	\$ 13.0M (96)	NC-Pocal	3QFY96	4QFY96

* Limited to U.S. manufacture per Public Law

POC: Ray Klapal/Rhonda Chuchwa (201) 724-4704.

OTHER PROCUREMENT ACTIONS

<u>ITEM DESCRIPTION</u>	<u>APPROX \$M</u>	<u>COMP/NON-COMP</u>	<u>ISSUE</u>	<u>EST AWARD</u>
M766 Short Range Ctg (95-98)	\$ 1.2M (95)	Competitive	04 Mar 96	Aug 96
Mortar Ballistic Computer	\$ 3.4M (96)	NC - Common Hardware	N/A	Apr 96
Electronic Time Fuze (For FCI) (FY96)	\$ 1.0M (96-97)	Limited Competition	Apr 96	Jun 96
M722 Fuze (FY96)	\$ 3.9M (96)	NC - Jumphans	Apr 96	Aug 96
M776 Fuze (FY96)	\$ 9.1M (96)	NC - Jumphans	Apr 96	Aug 96

USAIS Modernization Priorities

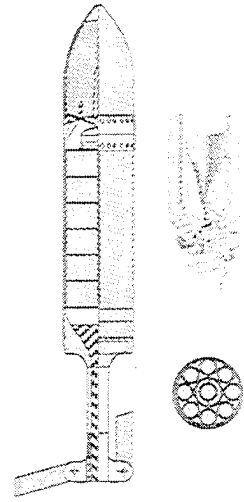
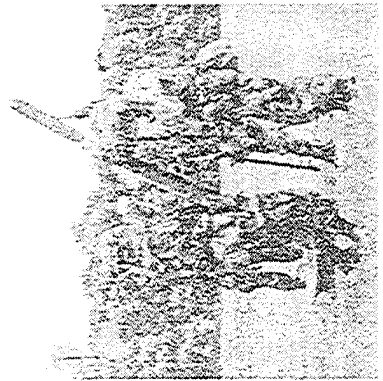
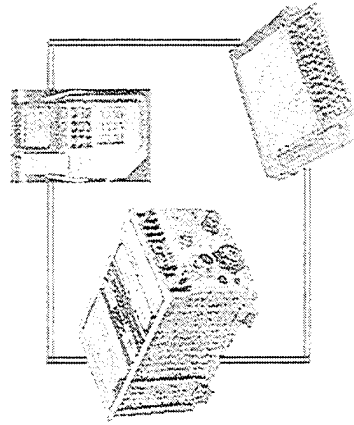
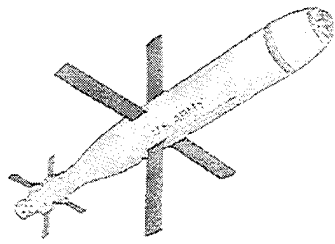
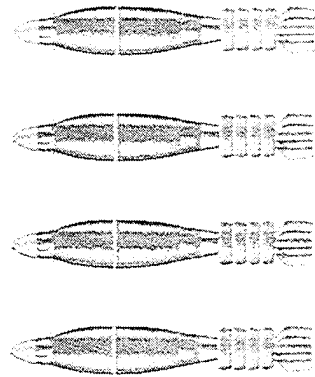
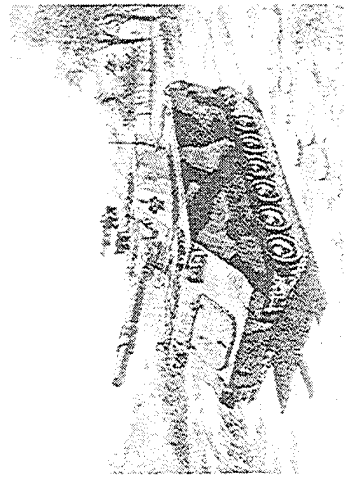

- Mortar Fire Control System
- Complete 120mm Family Of Ammunition
- Precision Guided Mortar Munition
- Composite Extended Range DPICM Ammunition
- Replace 81mm With Towed 120mm In Light Forces
- Turreted Mortar System

What is MFCS?

**The Mortar Fire Control System
will revolutionize the use of
mortars on today's battlefield**

- On-board Ballistics
- On-board POS/NAV
- Digital Communication

MFCs Components

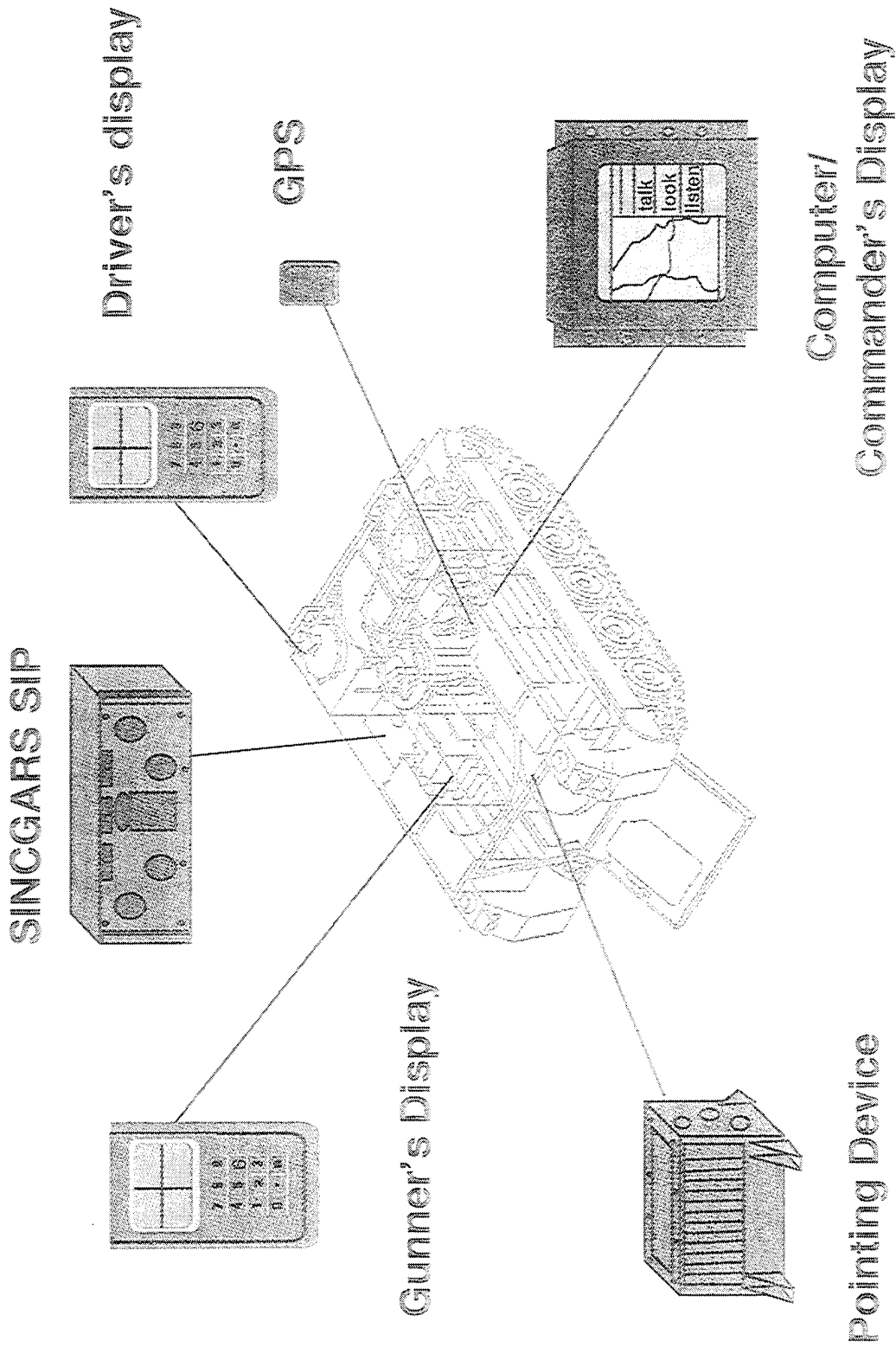

Leverages Army's significant investment in 120mm mortar

MFCs Capability Growth

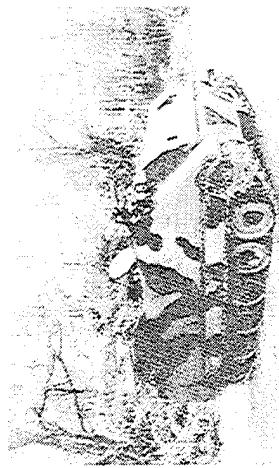

M1064

Demonstrator Vehicle

NTC 94-07:

- Optical link to DRU
- No Ballistics at Gun
- External GPS
- Voice Only Radio
- Swivel Chair Ops
- 4.2 In System

Focused Dispatch:

- DRU on Tube, Non Firing Only
- Ballistics at Gun
- Second Computer for Situational Awareness
- Digital Commo
- External GPS
- More Integrated Ops
- 120mm System

Objective System:

- Reference Unit on Gun-Shock Resistant
- One Computer w/FC, Sit Aware, GPS
- 188-220(a)/AFATDS compatible
- Fully Integrated System

Key Technologies

- Weapon pointing -
 - RLG/FOG
 - GPS-I
- Digital Commo -
 - SINGGARS
 - EPLRS
- Digital Fire Control Computer

Technical Challenges

- **Affordable/high accuracy pointing system (1-3 mil pointing accuracy)**
- **Shock mounting**
- **Reduce size/weight**
- **Limit cables/power required**

Program Goals

- **Reduced procurement time**
 - Competitive Best Value
 - Electronic RFD/Bulletin Board
 - Industry Input
 - Teamwork
- **Reduced development time**
 - Performance Based Specification
 - Teaming with Government/Contractor
 - Software Re-use

The MFCs program is Steamlined

Mortar Fire Control System

Program Funding

RDTE

	<u>96</u>	<u>97</u>	<u>98</u>	<u>99</u>	<u>00</u>	<u>01</u>	<u>02</u>	<u>03</u>	<u>04</u>	<u>05</u>	<u>Total</u>
Requirement	2.1	3.8	11.1	9.3							26.3

PROCUREMENT

	<u>00</u>	<u>01</u>	<u>02</u>	<u>03</u>	<u>04</u>	<u>05</u>	<u>06</u>	<u>Total</u>
Requirement	5.0	19.0	32.5	29.7	28.1	25.0	10.0	153.9
Qty Gun Tracks	23	83	113	109	108	116	48	600
Qty FDC	4	15	18	16	16	16	7	92

NOTES: Includes force package 1 and 2.

UNIT COST: Constant FY95 \$ Gun Track - 210,236; FDC \$146,170

120 mm Long Range DPICM Mortar Cartridge

Description

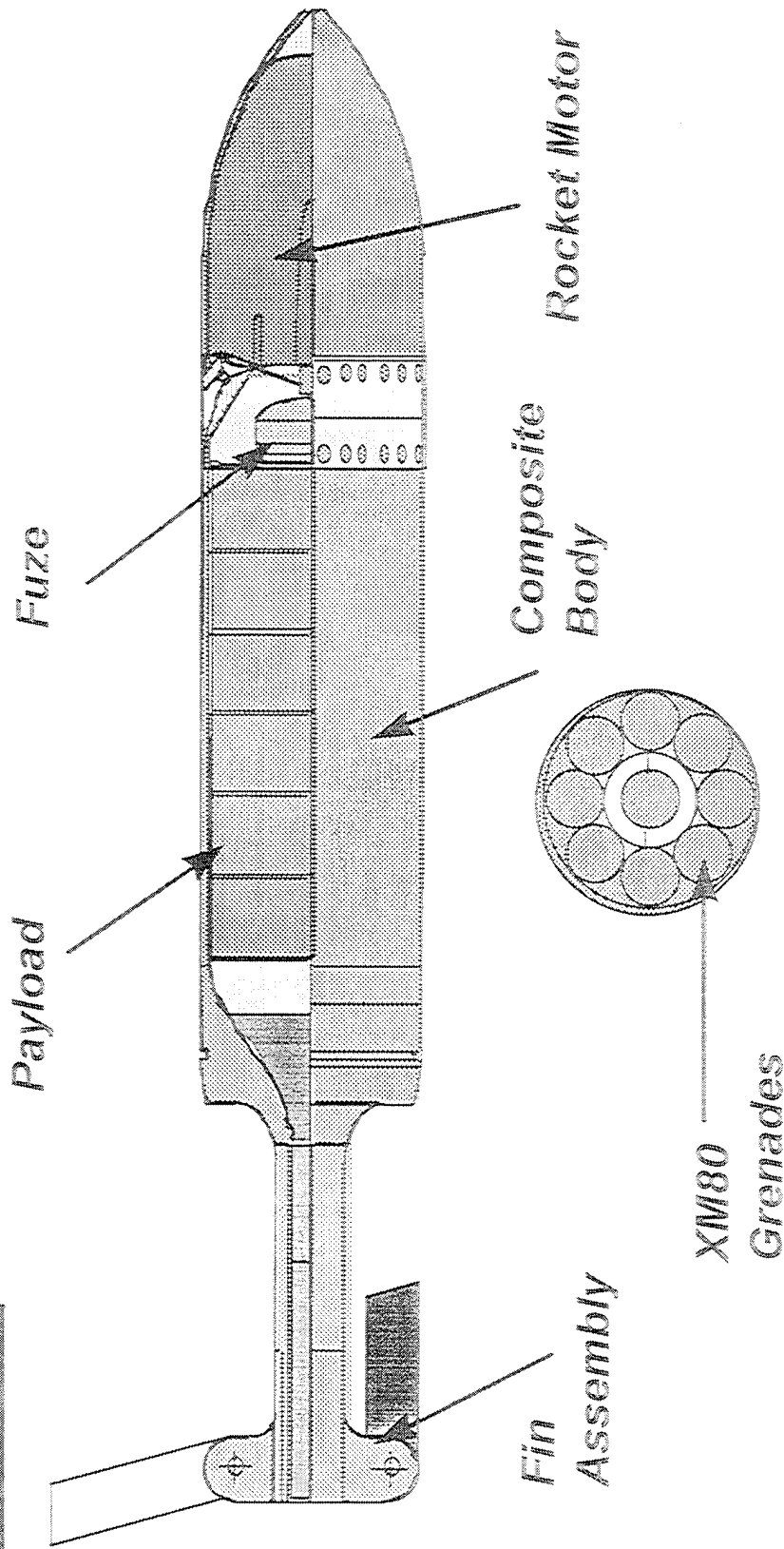

Maximum Range 11 km
Payload 54 XM80
Lethality 1.8 x M934

Multifunctional Electronic Fuzing
Lightweight Materials
Payload Flexibility

SCHEDULE/COST

	FY 1996	FY 1997	FY 1998	FY 1999	FY 2000	FY 2001	FY 2002	FY 2003
XM984								
CONCEPT DEMO/VALIDATION								
Projectile Design & Sim								
Fuze Concept Study								
PROOF OF PRINCIPLE								
Propulsion Update								
Design Fab Test								
Integrated Round Testing								
EMD								
Tech Test								
User Test								
TYPE CLASSIFY								
PRODUCTION/FUE								
6.2	250 (800)	(500) (2600) (400)	(4500) (1600)	(9000) (4000)	(10000) (3000)	(6500) (2000) (20000)	(40000)	(60000)
6.3								
RDT&E								
PAA								

NOTE: () denotes unfunded projectile costs
 () denotes unfunded fuze costs
 * UPC \$1200 for 100,000 rounds

PRECISION GUIDED MORTAR MUNITION

SEEKER SECTION	MIDBODY SECTION	WARHEAD SECTION	TAIL SECTION	PROPULSION SYSTEM
----------------	-----------------	-----------------	--------------	-------------------

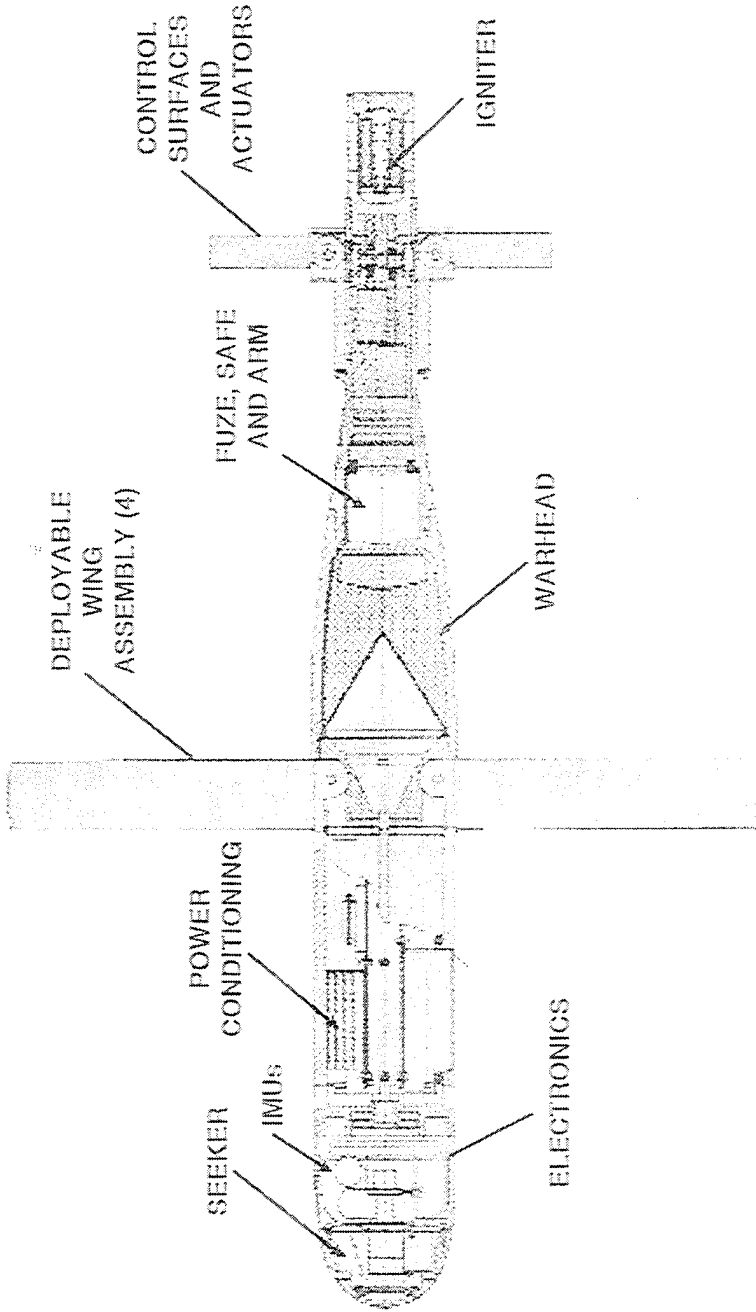

Capable of engaging high value point targets with semi-active laser mode
 Capable of engaging armor with autonomous infrared seeker
 Tandem warhead has demonstrated destruction of bunker and armor targets

PGMM PROGRAM PLAN

FY 95 96 97 98 99 00 01 02 03 04 05

Adv Tech Demo

EMD

Production

F(\$M) 5.6 10.2 7.0 4.2 4.0

U(\$M)

29 38 30 79 132 102

QTY(k)

2.5 7 7

• Includes \$6M Congressional Plus-Up In FY96

Point of Contact

Andrew J. Wood
APM, Advanced Programs/International Programs
Product Manager, Mortar Systems
Picatinny Arsenal, NJ 07806-5000

Phone (201) 724-5805

Fax -3909

***No country, its military critics
invariably discover afterward, is
ever adequately prepared in
munitions***

The Guns of August

INDUSTRIAL ECOLOGY CENTER

3 APR 96

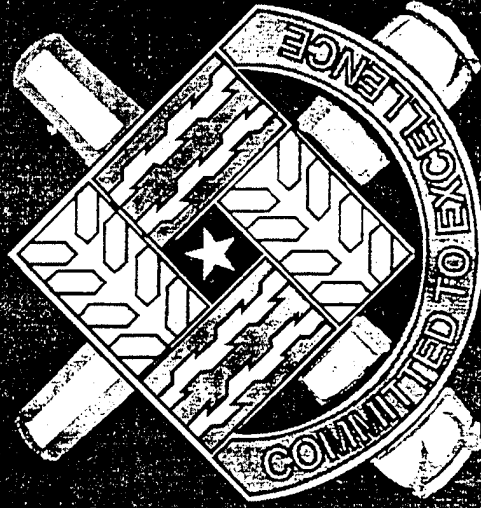

J.M. Argento, PhD
(201) 724-2428

OUTLINE

- Introduction to ARDEC's Industrial Ecology Center
- Success Stories
- Summary

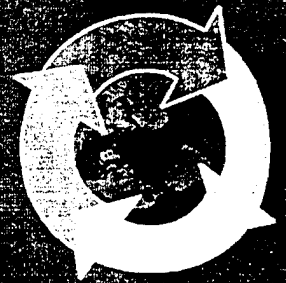

INDUSTRIAL ECOLOGY CENTER

Industrial Ecology Center

A flexible, responsive and skilled team of individuals that are a key resource for environmental technology and management practices in the Army, DOD and Industry

Located at the ARDEC, Picatinny Arsenal, NJ



INDUSTRIAL ECOLOGY CENTER

What is Industrial Ecology?

“Industrial Ecology” emphasizes the need to understanding the flow of materials and energy through industrial systems, the effects of these flows on the environment, and the influences of technology, regulations and operational practices on the flows. Industrial ecology incorporates such approaches as analyzing process flows, recycling wastes into inputs, examining the entire life cycle of products and designing products from the beginning with the environment in mind.

National Environmental Technology Strategy, April 1995



INDUSTRIAL ECOLOGY CENTER

Why Industrial Ecology?

Looks at total cost, addresses before-the-fact (R&D of product, materials and processes) rather than after-the-fact costs of violation, clean-up and remediation



INDUSTRIAL ECOLOGY CENTER

ORGANIZATIONAL STRUCTURE

MATRIX SUPPORT

ACQUISITION CENTER
 M. O'CONNELL x6630
 M. MORIAU x2016
 L. FRANZ x4894

LEGAL OFFICE

R. HENNESSY (ENV/LAW) x6584
 M. KANE (NDG/EE) x5502
 F. GOLDBERG (PAT/ENT) x6590
 D. SCOTT (GRDAS) x6585

TECHNICAL SUPPORT

R. BLAJDA, P.E. x5913

QUALITY ASSURANCE

H. VAN DYKE x4071

LEGEND

COMMERCIAL (201)724-XXXX
 DSN 880-XXXX
 FAX 201-724-8759/2314
 EMAIL: eto@plca.army.mil
 WEB SITE: <http://www.plca.army.mil/orgs/etorop.html>

INDUSTRIAL ECOLOGY CENTER

DIRECTOR	R. SCOLA, P.E.	x2044
ADM ASSISTANT	D. GOROG	x3279
SECRETARY	D. WARNER	x3279
COMPUTER ASST.	V. GRECO	x7524
FINANCIAL ANALYST	A. GROUNDARD	x2299
BUDGET ANALYST	D. GOBLE	x4007
ADM OFFICER	D. GOROG	x3279

ENVIRONMENTAL ANALYSIS

R. MOREIRA	x2617
L. PASTERICK	x7540
A. SCHWIERT	x4093
J. SHUM	x4071

ENVIRONMENTAL TECHNOLOGY

T. SACHAR x2364
 J. FRANKOVIC x5650
 J. BORRI, P.E. x5744

ADMIN SUPPORT

E. TOROLA x6336

THRUST MANAGERS

R. KATZ x6518
 R. GOLDBERG x4078
 D. YEE x6286
 M. NAPOLITANO x3615
 DR. J. DEFRANK 410-671-3972
 B. DONAHUE 217-373-3480
 R. BENJAMIN x2657

TECHNOLOGY DEMONSTRATIONS

NATIONAL DEFENSE CENTER FOR ENVIRONMENTAL EXCELLENCE

M. WRAZEN, (COR) x3730
 N. COLON x2482
 A. GOETZ, P.E. x6324
 D. DEMONE x6773

PROGRAM MANAGEMENT

G. KOSTECK, P.E., D.I.E. x6755
 D. TOLLIVER x4084

ADMIN SUPPORT

L. DEMARCO x4666

TECHNOLOGY DEVELOPMENT & TRANSITION

DR. ARGENTO x2428
 R. ZANOWICZ x5744
 J. THEIS x5795



Dept. of the Army
 Amament Research, Development and Engineering Center
 Industrial Ecology Center
 Building 172
 Picatinny Arsenal, NJ 07805-5000

WHAT "R" WE DOING?

- **Readiness**
 - **Manufacture**
 - **Maintenance**
 - **Training and Testing**
- **Reduction**
 - **Recycle, Recover, Reuse**
 - **Hazardous and Solid Waste**
- **Return on Investment**
 - **Tools**
 - **Methodology**

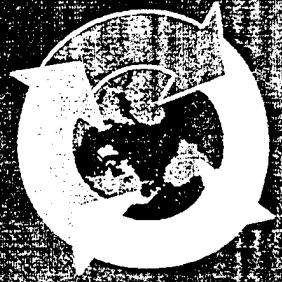

INDUSTRIAL ECOLOGY CENTER

FUNDING PROFILE

TOTAL BUDGET

<u>FY94</u>	<u>FY95</u>	<u>FY96**</u>
\$46M	\$36.9M	\$18.9M

** As of 21 FEB 96

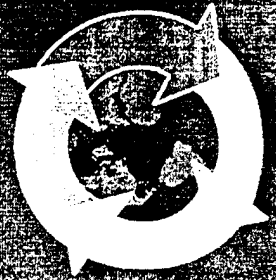

INDUSTRIAL ECOLOGY CENTER

Our customer base is increasing.

Customers

- DOD/DA
- PEO/PM
- OTHER SERVICES
- FEDERAL & STATE
EPA
- FOREIGN
GOVERNMENTS
- INDUSTRIAL BASE
- MANUFACTURING
AND ENGINEERING
CENTERS
- ACADEMIA

Potential Customers

- DEPARTMENT OF
AGRICULTURE
- DEPARTMENT OF
TRANSPORTATION
- DEPARTMENT OF
ENERGY
- DEPARTMENT OF
COMMERCE

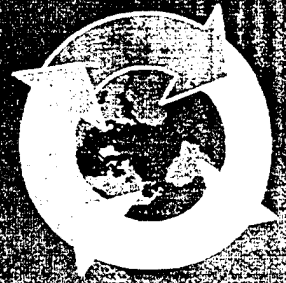

INDUSTRIAL ECOLOGY CENTER

CUSTOMERS' BENEFITS

- Availability of expertise
- Access to Government & NDCEE facilities
- Manage the entire program

"One Stop Life Cycle Organization"

- Leverage of R&D dollars and resources through team efforts
- Increased awareness of environmentally sound solutions
- Closer relationship with Government and Industry via CRDAs & Partnership



INDUSTRIAL ECOLOGY CENTER

“NO JOB TOO LARGE OR SMALL”

- **U.S. Army Pollution Prevention Environmental Quality Program**
- **DOD National Defense Center for Environmental Excellence (NDCEE)**
 - **Environmental Information Analysis System**
 - **Demonstration Factory**
 - **Contractor/Government Staff**
- **Environmental R&D Programs**
- **Demonstration Validation Program**



INDUSTRIAL ECOLOGY CENTER

HOW DOES IEC SUPPORT THE CUSTOMERS' NEEDS?

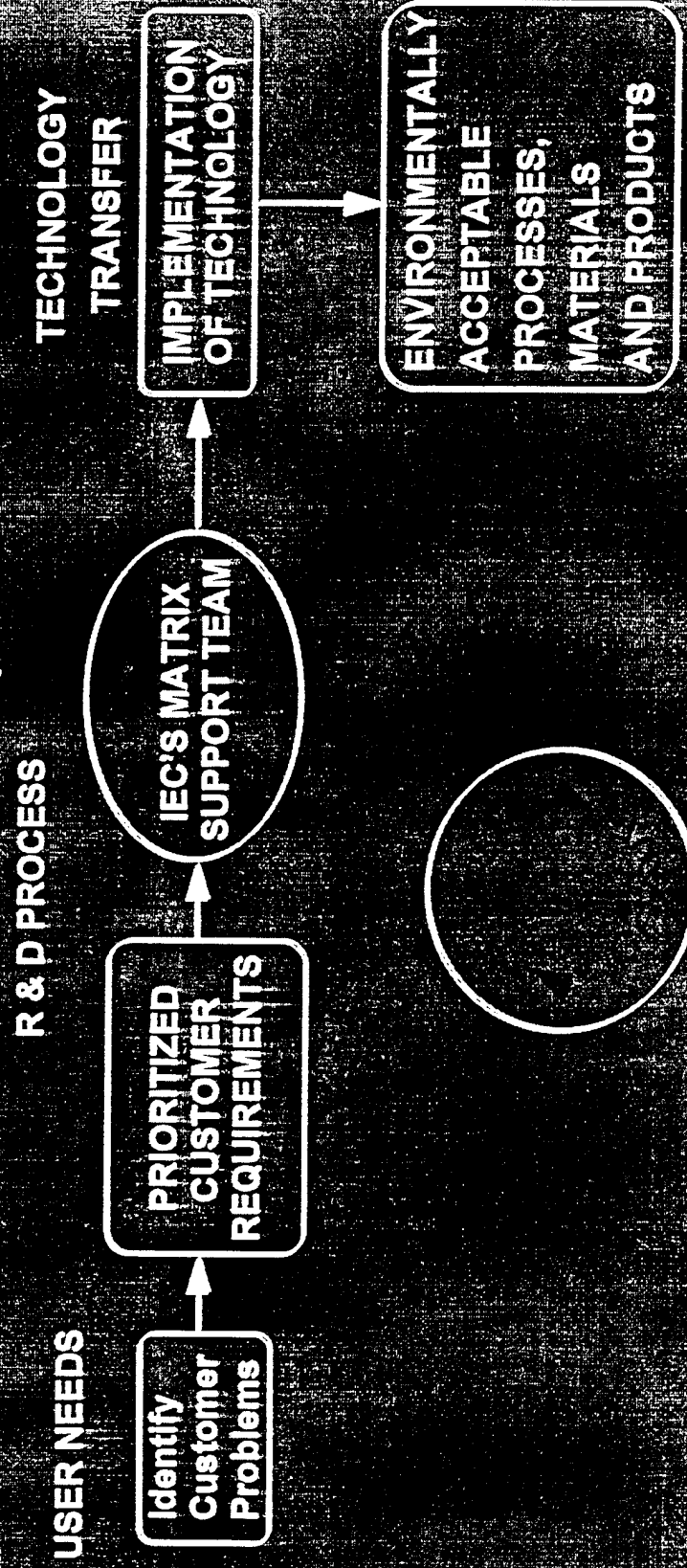

INDUSTRIAL ECOLOGY CENTER

Opportunities for Industry

- Small Business Innovation Research
- Working with the National Defense Center for Environmental Excellence
- Cooperative Agreements
- Cooperative Research and Development Agreements
- Strategic Environmental Research and Development Program
- Environmental Security Technology Certification Program

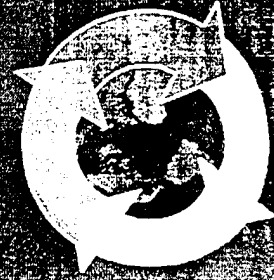

INDUSTRIAL ECOLOGY CENTER

IEC is involved all phases of complete product Life Cycle

Basic Research & Development

Demonstration/Validation

Engineering/Manufacturing Development

Operational System Development

Demilitarization

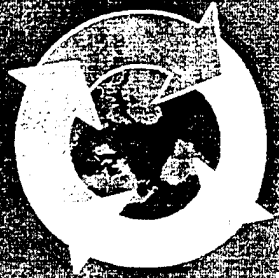

INDUSTRIAL ECOLOGY CENTER

SUCCESS STORIES

Green Bullet

INTEGRATED PRODUCT TEAM

- **Objective**
 - Hazardous material identification and replacement for the Green Bullet (5.56mm & 7.62mm)
- **Progress**
 - Hazardous material are being identified via spec/std review, TDP review and process audit
 - Analysis of toxic reduction inventory data and cost data at Lake City AAP scheduled
- **Benefits**
 - Eliminates Lead/Antimony in Projectile Core (1.9 million lbs/yr) and Primer (25 K Lbs/yr). Avoids Expensive Ventilation at Indoor Ranges (\$150 K/Range). In 1988, 600 Ranges Found Inadequate, Avoids Expensive Cleanup of Outdoor Ranges. Eliminates MEK, Toluene, and Xylene in Sealants and Lacquers.



INDUSTRIAL ECOLOGY CENTER

SUCCESS STORIES (Cont'd)

WASTE ACID DETOXIFICATION AND RECLAMATION SYSTEM @ WATERVLIET ARSENAL (P2 PROJECT, ESTCP)

- **Objective**
 - To use the latest technologies to recover the waste acid, separate it into its various components, and reuse the materials
- **Progress**
 - Would be installed and operated at Watervliet Arsenal for several months to study how well the system works
- **Benefits**
 - Up to \$120,000 a year could be saved in waste and, possibly, an additional \$28,000 in materials, disposable waste reduced by 70 tons, \$10M a year saving from using this technology, and DOD could more easily comply with new HazMat and pollution prevention standards.

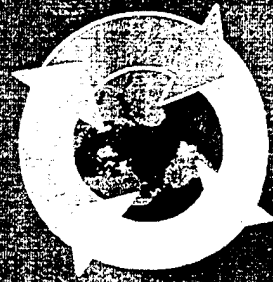

INDUSTRIAL ECOLOGY CENTER

SUCCESS STORIES (Cont'd)

Combustion Laser Detector (SERDP)

- **Objective**
 - To detect 12 Combustion Species by using Tunable Diode Laser Technology (ARL is working with Laser Photozone, Inc and Southwest Scientist Corp.)
- **Progress**
 - Demonstrated capability of Combustion Tunable Diode Laser Detector
- **Benefits**
 - Improve safety of crews by establishing levels of exposure to toxic gases as well as depletion of breathable air, comply with E.O. 12856 and improve military readiness.

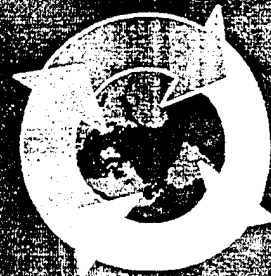

INDUSTRIAL ECOLOGY CENTER

SUCCESS STORIES (Cont'd)

Environmental Cost Analysis

- **Objective**
 - Develop Pilot Projects to Demonstrate the Use of Environmental Cost Accounting by the Federal Government and Coopers & Lybrand
 - Report on the Demonstration Projects and Make Recommendations on the Use of Environmental Cost Accounting in the Federal Government
 - Issue a Directive to Implement Environmental Cost Accounting in the Federal Government
- **Progress**
 - Documenting the nominated pilot projects for incorporation into a report on environmental cost guidelines
- **Benefits**
 - Provide federal decision makers with additional environmental cost information into existing cost accounting procedures and/or recognizing embedded environmental costs (training, pollution control, remediation costs, penalties, fines, and others) and allocating them to appropriate products of processes.



INDUSTRIAL ECOLOGY CENTER

SUCCESS STORIES (Cont'd)

New Jersey Institute of Technology & ARDEC
Solvent Reduction Project

- **Objective** (solvent substitutes for ammunition manufacturer)
 - Identify Solvent use in Military Specifications
 - Identify Specific Applications for Intensive Study
 - Identify Non-Solvent or Less Hazardous Solvent Opportunities
 - Determine Steps Necessary to Modify Specification and Technical Data Packages
- **Progress**
 - Reviewed Placatinny Specifications for Hazardous Materials: Ether Chosen
 - Determined Uses of Ether
 - Researching Possible Ether Alternatives
 - Reviewed Lake City AAP Manufacturing Process for Use: Solvent to be Determined
- **Benefits**
 - Cost savings, increased readiness, and comply with E.O. 12856

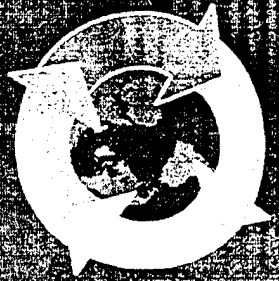

INDUSTRIAL ECOLOGY CENTER

SUMMARY

- One Stop Life Cycle Environmental Center
- Unique perspective of Installation, DA, DOD and other federal programs
- Flexible, responsive, skilled team with leveraged resources in government, industry and academia
- Good track record for implementation of technology
- Through NDCEE successful information clearinghouse for both the government and industry
- Valuable resources to DOD and industry
- Successful cooperative partnership and share quality objectives with our teams & partners
- Brokers for tomorrow's environmental technologies

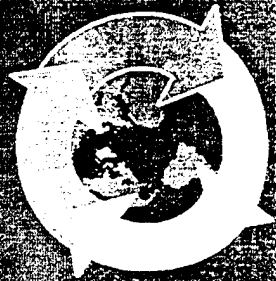

INDUSTRIAL ECOLOGY CENTER

NDCEH SUCCESS STORIES

- **Corpus Christi Army Depot (CCAD) Powertrain Cleaning used for cleaning engine, transmission, and powertrain components**
 - **Benefits:** Cost reductions thru reduced health liability and enhanced readiness by increased productivity (25%) which will improve peak production in wartime scenarios and eliminate dependence on ODCs.
- **Automated Ultrahigh-Pressure Waterjet Coatings Removal utilized to remove coating from jet engine seals (at CCAD)**
 - **Benefits:** 1 to 1.5 year payback period based upon a \$1M initial capital outlay, reduced coating removal time from 12 hrs to 20 mins with no substrate damage, eliminate hazardous processes and air emissions.
- **Plasma Arc Technology will be used to deal with Army's disposal of hazardous waste, toxic, carcinogenic, including organic, inorganic, heavy metals, and asbestos**
 - **Benefits:** Minimal waste pretreatment, easily scrubbed gaseous products, toxic waste stabilization in a leach-resistant and vitrified slag, process waste products, decreased air pollution control equipment costs thru low, off-gas volume, estimated \$100-\$2,000/ton and is highly dependent on the waste stream to be treated.



INDUSTRIAL ECOLOGY CENTER

NDORR SUCCESS STORIES

(continued)

- **Naval Aviation Depot- Jacksonville (NADEP- JAX) Powder Coating technology demonstrations with Navy aircraft components were successfully conducted and currently being implemented at Depot**
 - **Benefits:** Elimination of 6,700 lbs of VOC emissions and 28,000 lbs of hazardous waste discharges, reduce coating procurement cost by \$40,000 and realized an estimated 1.5 yr pay back, \$840,000 life-cycle savings.
- **Texas Instruments (TI) Powder Coating technology demonstrations with missile composite components are being performed and initially verified via tests the feasibility of powder coated composite radomes**
 - **Benefits:** Reduced VOC emissions and production cost, and use of excess capacity in the existing powder coating facility.
- **Englo Products Powder Coating technology demonstration was successfully performed for their products and has procured a powder coating system**
 - **Benefits:** Eliminated 27,000 lbs of VOCs/yr, improved product quality and productivity.



INDUSTRIAL ECOLOGY CENTER