

AL/CF-TR-1996-0056

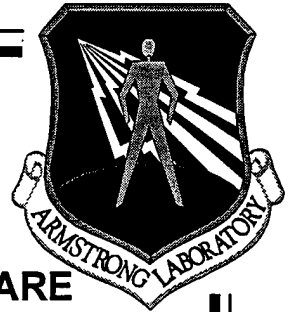

**TEST AND EVALUATION OF THE BAXTER HEALTHCARE
CORP., AUTO SYRINGE MODEL AS0GH-2 INFUSION PUMP**

Allen E. Jones, Technical Sergeant, USAF

**CREW SYSTEMS DIRECTORATE
Crew Technology Division
2504 Gillingham Drive, Suite 25
Brooks Air Force Base, TX 78235-5104**

19960613 068

May 1996

Final Technical Report for December 1993 to April 1995

Approved for public release; distribution is unlimited.

DTIC QUALITY INSPECTED 1

**AIR FORCE MATERIEL COMMAND
BROOKS AIR FORCE BASE, TEXAS**

**A
R
M
S
T
R
O
N
G**

**L
A
B
O
R
A
T
O
R
Y**

DISCLAIMER NOTICE



THIS DOCUMENT IS BEST QUALITY AVAILABLE. THE COPY FURNISHED TO DTIC CONTAINED A SIGNIFICANT NUMBER OF PAGES WHICH DO NOT REPRODUCE LEGIBLY.

NOTICES

This final technical report was submitted by personnel of the Systems Research Branch, Crew Technology Division, Armstrong Laboratory, AFMC, Brooks Air Force Base, Texas, under job order 7184-56-01.

This report was prepared as an account of work sponsored by an agency of the United States Government. Neither the United States Government nor any agency thereof, nor any of their employees, nor any of their contractors, subcontractors, or their employees, makes any warranty, expressed or implied, or assumes any legal liability or responsibility for the accuracy, completeness, or usefulness of any information, apparatus, product, or process disclosed, or represents that its use would not infringe privately owned rights. Reference herein to any specific commercial product, process, or service by trade name, trademark, manufacturer, or otherwise, does not necessarily constitute or imply its endorsement, recommendation, or favoring by the United States Government or any agency, contractor, or subcontractor thereof. The views and opinions of the authors expressed herein do not necessarily state or reflect those of the United States Government or any agency, contractor, or subcontractor thereof.

When Government drawings, specifications, or other data are used for any purpose other than in connection with a definitely Government-related procurement, the United States Government incurs no responsibility or any obligation whatsoever. The fact that the Government may have formulated or in any way supplied the said drawings, specifications, or other data, is not to be regarded by implication, or otherwise in any manner construed, as licensing the holder or any other person or corporation; or as conveying any rights or permission to manufacture, use or sell any patented invention that may in any way be related thereto.

The Office of Public Affairs has reviewed this report, and it is releasable to the National Technical Information Service, where it will be available to the general public, including foreign nationals.

This report has been reviewed and is approved for publication.

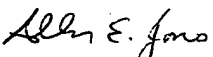
ALLEN E. JONES, TSgt, USAF
Aeromedical Research Technician

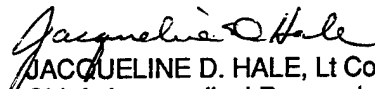
JACQUELINE D. HALE, Lt Col, USAF, NC
Chief, Aeromedical Research

JAMES P. DIXON, Colonel, USAF, BSC
Chief, Crew Technology Division

REPORT DOCUMENTATION PAGE

Form Approved
OMB No. 0704-0188

Public reporting burden for this collection of information is estimated to average 1 hour per response, including the time for reviewing instructions, searching existing data sources, gathering and maintaining the data needed, and completing and reviewing the collection of information. Send comments regarding this burden estimate or any other aspect of this collection of information, including suggestions for reducing this burden, to Washington Headquarters Services, Directorate for Information Operations and Reports, 1215 Jefferson Davis Highway, Suite 1204, Arlington, VA 22202-4302, and to the Office of Management and Budget, Paperwork Reduction Project (0704-0188), Washington, DC 20503.

1. AGENCY USE ONLY (Leave blank)	2. REPORT DATE May 1996	3. REPORT TYPE AND DATES COVERED Final, December 1993 - April 1995
----------------------------------	----------------------------	---

4. TITLE AND SUBTITLE Test and Evaluation of the Baxter Healthcare Corp., Auto Syringe Model AS20GH-2 Infusion Pump	5. FUNDING NUMBERS PE: 62202F PR: 7184 TA: 56 WU: 01
--	--

6. AUTHOR(S) ALLEN E. JONES, TSgt	
--	--

7. PERFORMING ORGANIZATION NAME(S) AND ADDRESS(ES) Systems Research Branch 2504 Gillingham Dr. STE 25 Brooks AFB TX 78235-5104	8. PERFORMING ORGANIZATION REPORT NUMBER
---	--

9. SPONSORING/MONITORING AGENCY NAME(S) AND ADDRESS(ES) Armstrong Laboratory (AFMC) Crew Systems Directorate Crew Technology Division 2504 Gillingham Dr. STE 25 Brooks AFB TX 78235-5104	10. SPONSORING/MONITORING AGENCY REPORT NUMBER AL-CF-TR-1996-0056
--	--

11. SUPPLEMENTARY NOTES

12a. DISTRIBUTION/AVAILABILITY STATEMENT Approved for public release; distribution unlimited.	12b. DISTRIBUTION CODE
--	------------------------

13. ABSTRACT (*Maximum 200 words*)

Air Training Command Surgeon General and the Department of Surgery, Willford Hall USAF Medical Center briefed, HQ AMC/SG (Brig Gen Roadman) on the feasibility of a Critical Care Aeromedical Transport Team. During this meeting, a request for evaluation of an Auto Syringe for airworthiness was presented. The director, Aeromedical Evacuation and Medical Plans & Requirements requested the Human Systems Center at Brooks AFB evaluate the Baxter Auto Syringe Model AS20GH-2 Infusion Pump. The unit is a light-weight portable infusion pump capable of providing a prescribed dose directly in mcg/kg/minute, mcg/minute, or ml/hour, eliminating the need for conversion tables. Aeromedical Research staff members within the Systems Research Branch, considers the unit conditionally acceptable for use in the aeromedical evacuation environment providing the unit is used "ONLY" on battery power.

14. SUBJECT TERMS Baxter medical equipment Auto Syringe Pump Syringe Pump acceptable aircraft Infusion Pump Airworthy	15. NUMBER OF PAGES 24
	16. PRICE CODE

17. SECURITY CLASSIFICATION OF REPORT UNCLASSIFIED	18. SECURITY CLASSIFICATION OF THIS PAGE UNCLASSIFIED	19. SECURITY CLASSIFICATION OF ABSTRACT UNCLASSIFIED	20. LIMITATION OF ABSTRACT UL
---	--	---	----------------------------------

TABLE OF CONTENTS

Section	Page
BACKGROUND	1
DESCRIPTION	1
METHODS	2
BASELINE.....	2
Initial Inspection.	3
Electrical Safety.	3
Battery Performance Test.....	3
Test Setup.....	3
Performance Check.....	4
VIBRATION.....	5
ELECTROMAGNETIC COMPATIBILITY	7
ALTITUDE	7
THERMAL/HUMIDITY	8
AIRBORNE FEASIBILITY.....	8
RESULTS.....	9
Initial Inspection	9
Electrical Safety.	9
Operation.....	9
Battery Performance Test.....	9
Vibration	9
Electromagnetic Compatibility.....	9
Altitude.....	10
Thermal/Humidity.....	10
Airborne Feasibility.....	10
REQUIREMENTS.....	10
CONCLUSIONS	10
REFERENCES	11
APPENDIX A.....	12

LIST OF FIGURES

Figure	Page
1. The Baxter Auto Syringe Model AS20GH-2.....	2
2. Test Setup Diagram.....	4
3. Test Setup Photograph.....	4
4. Sinusoidal & Random Vibration Signature	6

ACKNOWLEDGMENTS

I would like to thank the following individuals for their support during the evaluation of the Baxter Auto Syringe Model AS20GH-2 Infusion Pump: LtCol Jacqueline Hale, 1Lt Philip Preen, 2Lt Kindra Edman, Mr. Doug Townsend, MSgt Victor Elizondo, TSgt Mary Thomas, TSgt Butch Blake, personnel from ASC/ENAI and WL/AWA-2 Wright-Patterson AFB, and crews from the 433 AES Kelly AFB and 375 AES Scott AFB, and the 446 AES McCord AFB.

**TESTING AND EVALUATION OF THE
BAXTER HEALTHCARE CORP.
AUTO SYRINGE MODEL AS20GH-2 INFUSION PUMP**

BACKGROUND

Air Training Command Surgeon General and the Department of Surgery, Wilford Hall USAF Medical Center briefed, HQ AMC/SG (Brig Gen Roadman) on the feasibility of a Critical Care Aeromedical Transport Team (CCATT). During this meeting, a request for evaluation of an Auto Syringe for airworthiness was presented. The Director, Aeromedical Evacuation and Medical Plans & Requirements requested the Human Systems Center at Brooks AFB evaluate the Baxter Auto Syringe Model AS20GH-2 Infusion Pump.

DESCRIPTION

The Baxter Auto Syringe Model AS20GH-2 Infusion Pump (Fig 1), SN 104018, will hereinafter be called the pump. This unit is a light-weight portable infusion pump capable of providing a prescribed dose directly in mcg/kg/minute, mcg/minute, or ml/hour, eliminating the need for conversion tables. The dimensions of the unit are as follows: width 4.8 in (11.7 cm); length 8.2 in (20.8 cm); height 1.7 in (4.2 cm); weight 27 oz (765 gm). The pump is powered by rechargeable nickel- cadmium batteries located inside the pump. These batteries should be charged using 105-125V AC for at least 16 hours before the pump is placed in service. Battery life is rated at 5-24 hours, depending on product configuration, with a recharge time at 16 hours. In a hospital setting, the pump may be operated from 110 VAC or battery power. For a detailed description of features, refer to the Baxter Auto Syringe Model AS20GH-2 Operator's Manual.



Figure 1. The Baxter Auto Syringe Model AS20GH-2 Infusion Pump

METHODS

The Aeromedical Research Team developed an airworthiness test matrix incorporating military standards and addressing test procedures covering safety, human factors, environmental and engineering issues of concern to medical equipment items. A Procedures Guide (1) describes all tests in airworthiness assessment that an equipment device might experience during evaluation. The following information is derived from the Procedures Guide, and briefly describes the specific tests that are to be performed. Each device is first subjected to a Baseline Performance Assessment (BPA), a test of the operation of the device using directions and procedures described in the operator's manual (2).

Next, various tests were conducted that simulate the environment the device may encounter. We duplicated field storage and operational conditions as closely as possible. The tests were designed to assess one parameter at a time. Comparison to the performance check done during the BPA enabled us to assess each test's effect on the item. Data were collected by computer whenever possible, or recorded manually on specially formatted "Data Collection Sheets."

BASELINE

The Baseline Performance Assessment involved an initial inspection, electrical safety analysis and development of a test procedure and performance check.

Initial Inspection. The pump was inspected externally for faulty manufacture and possible damage incurred during shipment.

Electrical Safety. Biomedical Equipment Technicians and Aeromedical Research Engineers performed this evaluation on all electrical devices to ensure the safety of both the equipment operator and the patient. This assessment involved measuring the equipment's leakage current and ground-to-chassis resistance while the pump operated from 115VAC/60Hz and internal batteries, in addition to a general inspection of the device. The required limits are established in National Fire Protection Agency (NFPA) 99 (4), AFI 41-203 Electrical Shock Hazards (5), and Equipment Management in Hospital (6).

Battery Performance Test. The rechargeable nickel-cadmium batteries were rated for 24 hours at 2 ml/hr and 5 hours at 100 ml/hr. The recharge time should be at least 16 hours before the pump is reused. The 105 - 125V AC 60 Hz charger connects to the pump via a modular phone jack on the lower end of the pump. The pump was recharged for 16 hours between the 2 ml/hr and the 100 ml/hr tests to ensure that it operated as specified in the operator's manual.

Test Setup. The performance check was used to validate the function of the pump in each of the test conditions. Initial performance was assessed at standard ambient conditions and served as a baseline for later comparison. The following sequence was used to accomplish the test setup:

1. Filled the 60 ml syringe with 0.9% sodium chloride solution and placed it in the unit in accordance with operator's manual.
2. Programed the unit for the following settings: Body weight - 70 kg; concentration - 10 mg/ml; Dose - 200 mcg/kg/min; Rate - 84 ml/hr (unit automatically calculated this figure).
3. Connected 20-gauge 1.5-inch needle to the syringe.
4. Inserted needle into IV medication port end of 8-inch IV tubing.
5. Connected free end of tubing into 3-way stop cock.
6. Connected one end of 3-way stopcock to volumetric chamber using a 3-inch piece of tubing (Fig 2 & 3).
7. Secured free end of 3-way stopcock to a collection canister using an 8-inch piece of tubing.
8. Set Dynatech Nevada IV pump analyzer model 404A for volumetric output recording.
9. Set toggle switch to corresponding port used on the back of unit.
10. After turning on the tester, ensured that all displays illuminate.
11. While conducting the test, ensured that no bubbles were present in the line, or a false reading could be obtained.

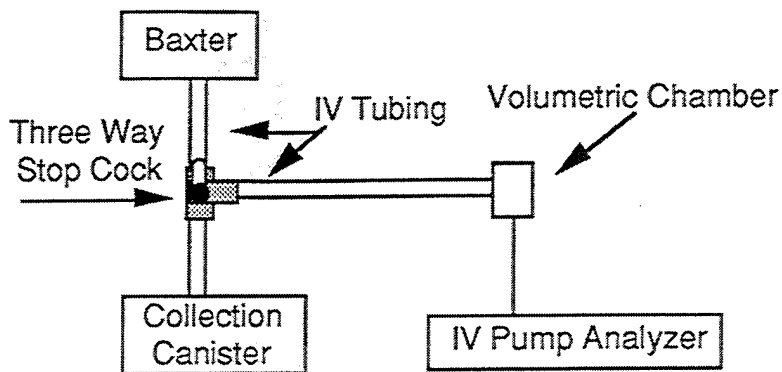

Figure 2. Test Setup



Figure 3. Test Setup

Performance Check. The following Performance Check was used to validate the function of the pump in each of the test conditions. Measurements taken during initial operation at standard ambient conditions served as a baseline for later comparison. The performance check was referenced throughout the test condition section. The procedure for this performance check was repeated three times to ensure validity and repeatability of test results. The performance test was done as follows: 60 ml syringe was filled with 50 ml of sodium chloride solution, placed into pump, and connected to IV tubing. The pump was started and the reading from the IV analyzer was logged. Three performance checks were done and recorded before, during, and after each laboratory test.

Vibration

Vibration testing is critical to determine "the resistance of equipment to vibrational stresses expected in its shipment and application environments" (810E). Vibration testing was conducted at the Aeromedical Research vibration facility. This testing involved a set of operational tests performed along each of the three axes of the pump - X, Y, and Z, with the pump mounted on the simulated litter on the shaker head as it would most likely be found on the aircraft. It was subjected to vibration curves with slightly modified levels and lengths from those depicted in Category 10, Figures 514.4-16 and 514.4-17 of MIL-STD-810E (Figures 4).

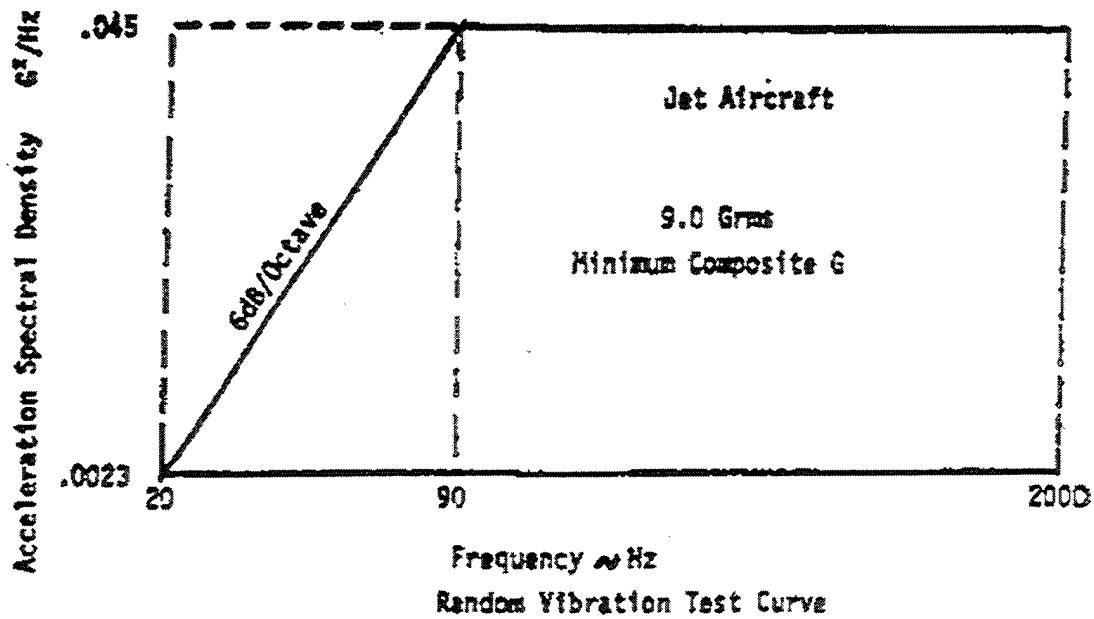
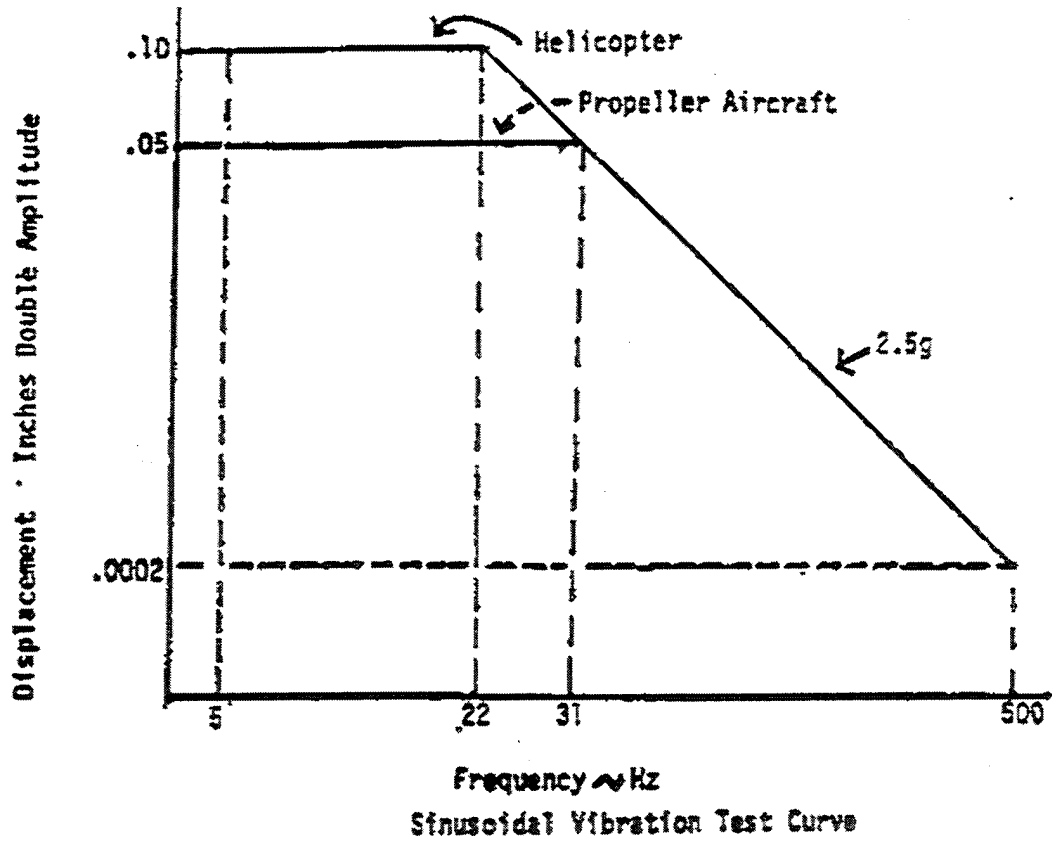

Figure 4. Sinusoidal & Random Vibration Signatures

Electromagnetic Compatibility

Testing was conducted in the Wright Laboratory EMI facility at Wright-Patterson AFB, OH with personnel from the Avionics Warfare Branch (WL/AAWA-2) and the Avionic Engineering Division, Design Integrity Branch (ASC/ENAI). The purpose of EMI testing was to assess compatibility with aircraft systems. Evaluation was conducted following MIL-STD-462 (7) to verify compliance with MIL-STD-461D (8). Specific tests were as follows:

Radiated Emissions (RE-102): "Radiated Emissions, Electric Field, 2 MHz to 1 GHz." This test determined the amount of EMI emitted by the equipment during its operation. This test was performed to ensure that the device did not affect other pieces of equipment that may be susceptible to EMI (i.e., aircraft navigation and communication equipment).

Conducted Emissions (CE-102): "Conducted Emissions, Power Leads, 10 KHz to 10 MHz." This test measured emissions generated by the components and conducted through the aircraft power lines. This test was performed to ensure that operating the device using line power did not affect other items connected to the same power source, particularly aircraft systems.

Radiated Susceptibility (RS-103): "Radiated Susceptibility, Electric Field, 30 MHz to 12.4 GHz." This test determined whether or not the pump withstand pre-defined levels of EMI generated by antennas both internal and external to the aircraft.

Conducted Susceptibility (CS-101): "Conducted Susceptibility, Power Leads, 30 Hz to 50 KHz." This test determined whether the components withstand ripple voltages associated with allowable distortion of power source voltage wave forms.

Conducted Susceptibility (CS- 114): "Conducted Susceptibility, Bulk Cable Injection, 10 KHz to 400 MHz." This test was performed to determine whether simulated currents that are developed on platform cabling from electromagnetic fields generated by antenna transmission affect the equipment under test.

Conducted Susceptibility (CS-115): "Conducted Susceptibility, Bulk Cable Injection, Impulse Excitation." This test was performed to ensure the pump could withstand the fast rise and fall time that may be present due to platform switching operations and external transient environments such as lightning and electromagnetic pulse.

Altitude

Cabin Pressure/Altitude Testing. The purpose of testing in the hypobaric chamber was to approximate the stresses of the airborne environment due to the effects of reduced barometric pressure. The standard protocol for the test was a climb to 10,000 feet (chamber pressure of 522 mmHg) at an ascent rate of 5,000 feet (ft) per minute, stopping at every 2,000 ft increment to assess test item operation and compliance with the prescribed operating parameters.

We evaluated the operational capability of the pump using battery power only during actual flight conditions on the C-9, C-130, and C-141, integrated it with aircraft systems, performed on/off load procedures, securing methods, medical crew interface, and other human factor evaluations.

RESULTS

Initial Inspection

Visual Inspection. No damage or defects were noted.

Electrical Safety. Ground resistance and current leakage were acceptable.

Operation. No discrepancies were noted during the operational verification. Alarms functioned as stated in the manufacturer's literature; however, audible alarms may not be effective in the noisy airborne environment.

Battery Performance Test. The pump passed battery performance tests, lasting according to manufacturer specifications.

Vibration

The pump passed all critical phases of testing. The pump went into the standby mode during Sine Y testing. This was not considered a failure since it should not pose a hazard. The standby mode light illuminated and the auto syringe was easily reactivated. The pump was subjected to approximately 29 hours of aircraft vibrations incurred during take-offs, cruise altitudes, landings, and turbulent flight conditions. The pump remained operational and did not default to the standby mode.

Electromagnetic Compatibility

The pump passed all Air Force emissions requirements, but is susceptible to Radio Frequency (RF) energy in the frequency range of 40 MHz to 200 MHz while operating from 115V 60 Hz power. Aircraft transmitting systems in this frequency range are the VHF/FM radio (30 - 88 MHz) and the VHF/AM radio (116 -154 MHz). These transmitters typically have an output power of 20 watts or less and present a chance of causing performance degradation. Ground-based high-power transmitters (television, radio, commercial communications, VOR, etc.) also present a chance of causing interference. Susceptibility problems observed during testing varied from minor deviations to complete shutdown without alarms sounding. ASC/ENAI recommended electromagnetic (EM) modifications to pass all susceptibility tests. However, the Baxter Corp. chose not to make these modifications due to discontinuation of this model. Therefore, the pump is certified for use on battery power only.

Altitude

Cabin Pressure/Altitude Testing. The pump operated satisfactorily.

Rapid Decompression. The pump operated satisfactorily during and after each decompression. While inside the chamber, the pump delivered its volume in a graduated beaker. The pump was observed and allowed to continue to operate, then the chamber was returned to ground level. At ground level, the IV pump analyzer was utilized to accomplish three post tests.

Thermal/Humidity

The pump operated satisfactorily during all thermal and environmental testing.

Airborne Feasibility

The pump operated on battery power satisfactorily, was "user friendly," and easy to enplane/deplane. It was secured to a pair of equipment brackets attached to an equipment litter on a C-9 at TL-1 litter tier, middle litter space and on a C-130 K litter tier, second litter space. The pump was also secured to an auto syringe bracket attached to a Neonatal Transport System (NTS) on a C-9 secured at TR-1 and TR-2 litter tiers, and on a C-141 secured forward of I/H litter tier. The pump remained operational while being subjected to a total of 11 takeoffs, 11 landings, inflight vibrations, and during turbulent flight conditions. The pump should be positioned, if possible, for visual detection since audible alarms could not be heard on a C-130 or C-141. On a C-9 the audible alarms could only be heard between 2 - 5 feet, depending on the phase of flight.

REQUIREMENTS

The Baxter Auto Syringe Model AS20GH-2 Infusion pump is acceptable for inflight use on all USAF aircraft, provided the following requirements are met:

1. Operate on battery power only.
2. Do not charge the battery inflight.
3. Charge the battery for 16 hours prior to flight.
4. Visually monitor unit for alarm activation.

CONCLUSIONS

Overall, the Infusion pump is considered airworthy and met all of the standards and limits outlined in our references for testing aeromedical evacuation equipment while operating on battery power. Provided the above requirements are met, the Baxter Autosyringe Model AS20GH-2 Infusion Pump may be used during any patient transport on all USAF aircraft.

REFERENCES

1. Aeromedical Research Procedure Guide, (1995) Internal Operating Instruction, Systems Research Branch, Armstrong Laboratory
2. Baxter Auto Syringe Model AS20GH-2 Infusion Pump, Operator's Manual
3. MIL-STD-810E, Environmental Test Methods and Engineering Guidelines
4. National Fire Protection Agency (NFPA) 99, Health Care Facilities Code
5. AFI 41-203, Electrical Shock Hazards
6. AFI 41-201, Equipment Management in Hospitals
7. MIL-STD-462D, Measurement of EMI Characteristics
8. MIL-STD-461D, Electromagnetic Emissions and Susceptibility Requirements for The Control of Electromagnetic Interference, Category A1e

APPENDIX A

APPENDIX

MANUFACTURER'S SPECIFICATIONS OF THE BAXTER AUTO SYRINGE MODEL AS20GH-2 INFUSION PUMP

Manufacturer:	Baxter Healthcare Corporation P.O. Box 490 Round Lake, IL 60073 (708) 546-6311
Dimensions:	4.8 x 8.2 x 1.7 inches 11.7 x 20.8 x 4.2 centimeters
Weight:	27 ounces 765 grams
Accuracy:	±3% (not including syringe intolerance) ±.1 ml for bolus infusions ≤ 3 ml (not including syringe intolerance)
Syringes Accepted:	Plastipak (B-D) 60 ml Monojet 60 ml
Maximum Total Volume:	52 ml
Power Requirements:	105 - 125V AC/60 Hz (Do not use the AC power source inflight) DC internal nickel-cadmium batteries
Battery Life:	24 hours at 2 ml/hr 5 hours at 100 ml/hr
Alarms and Warnings:	Keyboard Idle Warning Invalid Key Command Incomplete Data Change Sequence High Pressure System Low Volume
Battery Status Indicators:	Low Battery Bad Battery On Charge
Operating temperature:	0° C to 49° C (32° F to 120° F)
Construction:	High impact case. Water resistant, touch sensitive switch panel.

INFORMATION DISPLAYS:

TOP

MIDDLE

BOTTOM

For mcg/kg/min Mode:
RATE ml/hr

CONC mg/ml

DOSE mcg/kg/min

For ml/hr Mode:
RATE ml/hr

TOTAL ml

BLANK

For mcg/min Mode:
RATE ml/hr

CONC mg/ml

DOSE mcg/min