

DOT/FAA/AR-96/23

Office of Aviation Research
Washington, D.C. 20591

Improved Cabin Smoke Control

May 1996

Final Report

This document is available to the U.S. public
through the National Technical Information
Service, Springfield, Virginia 22161.



U.S. Department of Transportation
Federal Aviation Administration

19960619 060

DISCLAIMER NOTICE

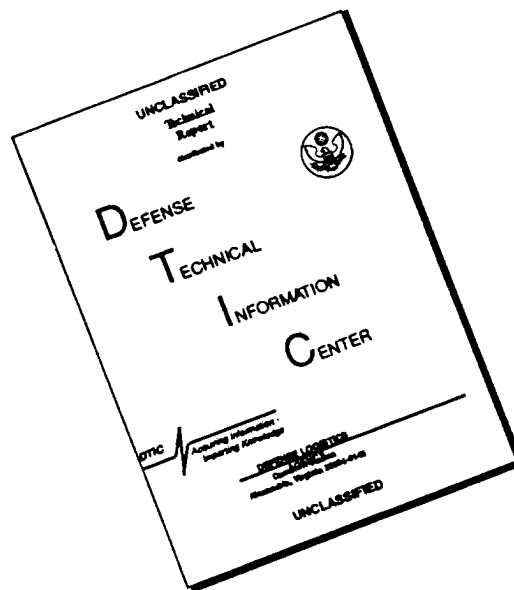

THIS DOCUMENT IS BEST QUALITY AVAILABLE. THE COPY FURNISHED TO DTIC CONTAINED A SIGNIFICANT NUMBER OF PAGES WHICH DO NOT REPRODUCE LEGIBLY.

NOTICE

This document is disseminated under the sponsorship of the U.S. Department of Transportation in the interest of information exchange. The United States Government assumes no liability for the contents or use thereof. The United States Government does not endorse products or manufacturers. Trade or manufacturer's names appear herein solely because they are considered essential to the objective of this report.

1. Report No. DOT/FAA/AR-96/23		2. Government Accession No.		3. Recipient's Catalog No.	
4. Title and Subtitle IMPROVED CABIN SMOKE CONTROL				5. Report Date May 1996	
				6. Performing Organization Code	
7. Author(s) Allen Porter				8. Performing Organization Report No.	
9. Performing Organization Name and Address Omega Technical Services 2297 7th Ave. Milton, WA 98354				10. Work Unit No. (TRAIS)	
				11. Contract or Grant No. DTS-57-93-C-00125	
12. Sponsoring Agency Name and Address U.S. Department of Transportation Federal Aviation Administration Office of Aviation Research Washington, D.C. 20591				13. Type of Report and Period Covered Final Report	
				14. Sponsoring Agency Code AAR-423	
15. Supplementary Notes FAA Technical Center COTR: Thor Eklund					
16. Abstract The major features and performance parameters of the Boeing 757 cabin ventilation system are described within the context of cabin smoke control. Two design changes were developed and evaluated. In the first design, additional ventilation outflow valves are located on the upper part of the fuselage and cabin ventilation is modified to provide air delivery in either the front or rear half of the fuselage. The second proposed design involves establishing the capability of reversing the ventilation flow so that it enters at the cabin floor and exits into the ceiling air distribution ducts. The technical feasibility of the design changes was assessed through installation complexity, added weight, and estimated effectiveness. Elements requiring further study were also identified. DTIC QUALITY INSPECTED 2					
17. Key Words Aircraft, Fire, Smoke, Ventilation, Pressurization, Environmental control				18. Distribution Statement This document is available to the public through the National Technical Information Service (NTIS), Springfield, Virginia 22161.	
19. Security Classif. (of this report) Unclassified		20. Security Classif. (of this page) Unclassified		21. No. of Pages 56	22. Price

TABLE OF CONTENTS

	Page
EXECUTIVE SUMMARY	ix
INTRODUCTION	1
SCOPE	1
RESEARCH OBJECTIVES	1
Identification and Significance of the Problem	1
Phase I Technical Objectives	2
RESEARCH WORK CARRIED OUT	2
Description of The Production B-757 Environmental Control System (ECS)	2
Air Conditioning	5
Pressurization	11
Concept 1 for Improved Smoke Control	15
Description of Concept 1—ECS Modified for Smoke Control and Evaluation	16
Operation of the Modified ECS in the Smoke Control Mode—Concept 1	17
ECS Modifications Required for Concept 1	21
Performance Assessment of Concept 1	28
Implications of Concept 1 Modifications	29
Elements Requiring Further Study	30
Concept 2 for Improved Smoke Control	31
Description of Concept 2—Reversed ECS Flow	31
Operation of the Modified ECS in the Smoke Control Mode—Concept 2	31
ECS Modifications Required for Concept 2	34
Performance Assessment of Concept 2	36
Implications of Concept 2 Modifications	36
Elements Requiring Further Study	37

RESULTS	37
Estimates of Technical Feasibility	37
Comparisons of Concepts 1 and 2	38
Effectiveness in Controlling Smoke	38
CONCLUSIONS	40
REFERENCES	41
APPENDIX—PHOTOGRAPHS OF ECS INSTALLATION	

LIST OF FIGURES

Figure		Page
1.	B-757 Environmental Control System	3
2.	ECS Subsystems	4
3.	ECS Distribution	6
4.	ECS Supply	8
5.	Passenger Compartment Conditioned Air Distribution	10
6.	Normal Conditioned Air Flow in Cabin	11
7.	Cabin Pressure Outflow Valve	12
8.	Cabin Pressure Control System	13
9.	Pressurization Control Equipment Location	14
10.	Auto Pressurization Schedules	15
11.	Normal ECS Flow	19
12.	ECS Flow in Smoke Control Mode—Concept 1	20
13.	Smoke Vent Locations	22
14.	Elliptical Centerline Duct Configuration	24
15.	Centerline Distribution Duct (New Design)	25
16.	Valves Installed in Centerline Distribution Duct (Typical, Both Designs)	26
17.	Ram Air Modifications	27
18.	Concept 2—Reversed Flow In The Cabin	32
19.	Concept 2—Smoke Collection And Exhaust In Reversed Flow	33
20.	Concept 2 Ducting	35

LIST OF TABLES

Table	Page
1. B-757 ECS Flow Rates	9
2. Estimated Weights—Concept 1	29
3. Estimated Weights—Concept 2	37
4. Comparisons of Concepts 1 and 2	39

ABBREVIATIONS AND DEFINITIONS

A/C	Air Conditioning
ACM	Air Cycle Machine—An element of the air conditioning pack that compresses and expands engine bleed air.
APU	Auxiliary Power Unit
BITE	Built In Test Equipment
cfm	cubic feet per minute
ECS	Environmental Control System
Flashover	The point in a fire when heat from the surroundings causes combustible materials in the area to rise above their ignition temperature resulting in wide spread spontaneous ignition.
Flow Control Valve	An electro-pneumatic valve that controls the airflow rate from the pneumatic distribution system to the pack.
msl	mean sea level
Outflow Valve	A valve in the shell of the fuselage that allows air to escape and automatically controls the internal pressure of the aircraft.
Pack	The portion of the ECS that provides a supply of conditioned air to the cabin, flight deck, and cargo compartments and which provides aircraft pressurization required for high-altitude flight.
psia	pounds per square inch absolute
psig	pounds per square inch gauge
PSU	Passenger Service Unit
Ram Air System	Part of the ECS that ingests outside air during flight to cool bleed air and, if required, the ACM compressor discharge.

EXECUTIVE SUMMARY

While infrequent, the occurrence of an in-flight fire aboard a commercial aircraft presents an extremely dangerous situation. When fire occurs in the passenger cabin, the resulting accumulation of smoke and hot gases quickly creates life-threatening conditions for the occupants and can ultimately lead to fire flashover if not controlled during the time it takes the crew to land and evacuate the airplane. In those few cases where the emergency has developed beyond the ability of the equipment and crew to cope with it, the results have been catastrophic.

The Environmental Control System (ECS) of modern aircraft is designed to provide air conditioning, pressurization, and ventilation of the cabin. However, when large quantities of smoke and hot gas are generated in the cabin, the ability of the ECS to maintain a survivable environment may be exceeded.

This study describes the elements and normal operation of the Boeing 757 ECS and presents two concepts for modifying the system so that it could provide improved emergency smoke control while still performing its primary functions.

The first concept extends work previously done by Boeing and the Federal Aviation Administration (FAA) and involves modifying the ECS by adding two smoke vents in the fuselage upper lobe which are similar to the lower lobe pressurization outflow valve and changing the fresh air flow so that it exhausts smoke from the upper fuselage lobe.

The second concept involves modifying the ECS so that in the smoke control mode the usual direction of air flow in the cabin is reversed causing it to enter at floor level and exhaust at the ceiling. Smoke is collected by the air conditioning distribution system and exhausted overboard from the lower lobe.

Both concepts consider the tendency of hot smoke and gas to rise to the cabin ceiling due to buoyancy effects; however, each takes a different approach to redirecting fresh air flow to control and evacuate the smoke.

The scope of the study did not allow for quantitative performance analyses of the ECS with the proposed changes or for detailed designs of the modifications required by each concept to be made. These items will remain subjects for further study.

The conclusions reached in the study are that both concepts appear to be technically feasible and would allow the ECS to provide improved cabin smoke control during an in-flight fire emergency. The results suggest that of the two, Concept 1 may be more effective, lighter weight, and simpler to implement. Tests will be required to conclusively demonstrate the effectiveness of either concept.

INTRODUCTION

This Phase I Small Business Innovative Research (SBIR) program studied two concepts for controlling and eliminating the accumulation of smoke in commercial aircraft cabins in the event of an in-flight fire. The two concepts involve making modifications to the aircraft's Environmental Control System (ECS) and operating it in a smoke control mode during an in-flight cabin fire emergency. The study was conducted on the Boeing 757, which is a mature production aircraft representative of modern jet airliner technology.

This report presents a description of the production B-757 ECS and its operation under normal conditions. The two concepts for enhanced smoke control and the required ECS modifications for each are described, and their characteristics and estimated performance are discussed.

The study was performed by Omega Technical Services, Milton, WA, under SBIR Contract No. DTS-57-93-C-00125. Allen Porter was the Principal Investigator. Technical data, illustrations and photographs of the B-757 ECS were provided by the Boeing Commercial Airplane Group for the purposes of the study. Boeing also arranged for the writer to visit the B-757 production line to observe the installation of ECS equipment in production airplanes. Elliott Maylor, retired Boeing ECS Engineer, offered valuable advice and critique during the study.

SCOPE

The scope of the Phase I study was limited to the B-757 which had been used as a model in previous smoke venting studies. The two methods of smoke control described were developed for the ECS of this airplane, and their application to other aircraft was not determined.

The modifications to the ECS required for each method were developed on a conceptual basis. Implementation of either method will require detailed design and analysis of various aircraft systems, which were beyond the scope of this study. Identification of these requirements and other elements requiring further study are presented.

RESEARCH OBJECTIVES

IDENTIFICATION AND SIGNIFICANCE OF THE PROBLEM.

While statistically infrequent in terms of overall aircraft operations, there nonetheless have been numerous cabin fire/smoke incidents reported aboard commercial aircraft flights [1]. In several cases where the situation has developed beyond the ability of the equipment and crew to cope with the emergency, catastrophic results have occurred.

The 1973 Varig B-707 accident near Paris, the Saudi L-1011 accident at Riyadh in 1980, and the Air Canada DC-9 accident near Cincinnati in 1983 accounted for 447 fatalities as the result of in-flight fires. At least five serious cabin fire incidents, which did not involve fatalities, were recorded from 1985 through 1990.

When smoke and toxic gas products from fire occur in the passenger cabin, the hot gases rise to the cabin ceiling where they accumulate and eventually spread throughout the cabin. The resulting temperature at the ceiling may reach 400 - 500°F, and visibility is reduced until near total obscuration occurs. If allowed to continue, the accumulation of hot gases ultimately may lead to fire flashover, resulting in certain loss of the airplane. This sequence of events may occur quite rapidly, depending upon the size of the fire, and it is imperative that the airplane be landed and passengers evacuated in the least time possible.

During the emergency, if the smoke and gases are not vented from the cabin, lack of visibility and eventual incapacitation of the occupants will make successful evacuation extremely difficult or impossible.

The Environmental Control System of modern aircraft provides air conditioning, pressurization, and ventilation of the cabin. In the event of an in-flight cabin fire, the ECS must maintain a survivable environment as the crew attempts to control and extinguish the fire, make an emergency landing, and evacuate the occupants. Although the ECS was not primarily designed for smoke evacuation, with certain modifications, it could be made to better handle this task in an emergency while still performing its intended functions.

PHASE I TECHNICAL OBJECTIVES.

The technical objectives of this study were to

- Develop an understanding of the B-757 ECS and how it operates under normal conditions.
- Study and evaluate two concepts for modifying the B-757 ECS to enhance its capability to control and evacuate smoke from an in-flight cabin fire.
- Identify the changes to the ECS required for each concept.
- Assess the technical feasibility of each concept.

RESEARCH WORK CARRIED OUT

The study was carried out as five tasks over a period of six months including literature review, data acquisition from Boeing and other sources, concept development and analysis, feasibility assessment, and preparation of the final report. A discussion of the data and the results of the study are presented, beginning with a description of the ECS as it exists in production B-757s.

DESCRIPTION OF THE PRODUCTION B-757 ENVIRONMENTAL CONTROL SYSTEM (ECS).

The B-757 ECS performs three major functions: air conditioning, equipment cooling, and pressurization. These are handled by multiple subsystems which together provide a controllable environment for the cabin areas (flight deck and passenger compartments), cargo compartments,

and the electrical/electronics equipment areas. This study is principally concerned with the air conditioning and pressurization systems as they relate to smoke control.

The ECS is a two-pack air cycle system that uses engine bleed air during engine operation or a pneumatic ground cart or the airplane Auxiliary Power Unit (APU) as the air source during ground operations. Figure 1 is a block diagram of the ECS and figure 2 shows the relationship of the equipment in the airplane.

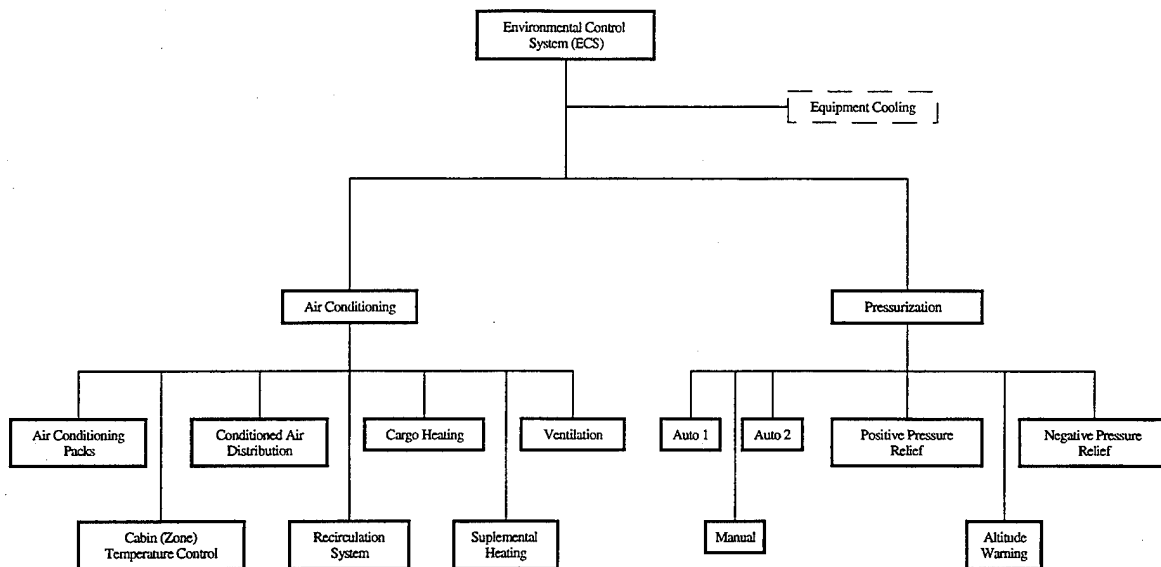

FIGURE 1. B-757 ENVIRONMENTAL CONTROL SYSTEM

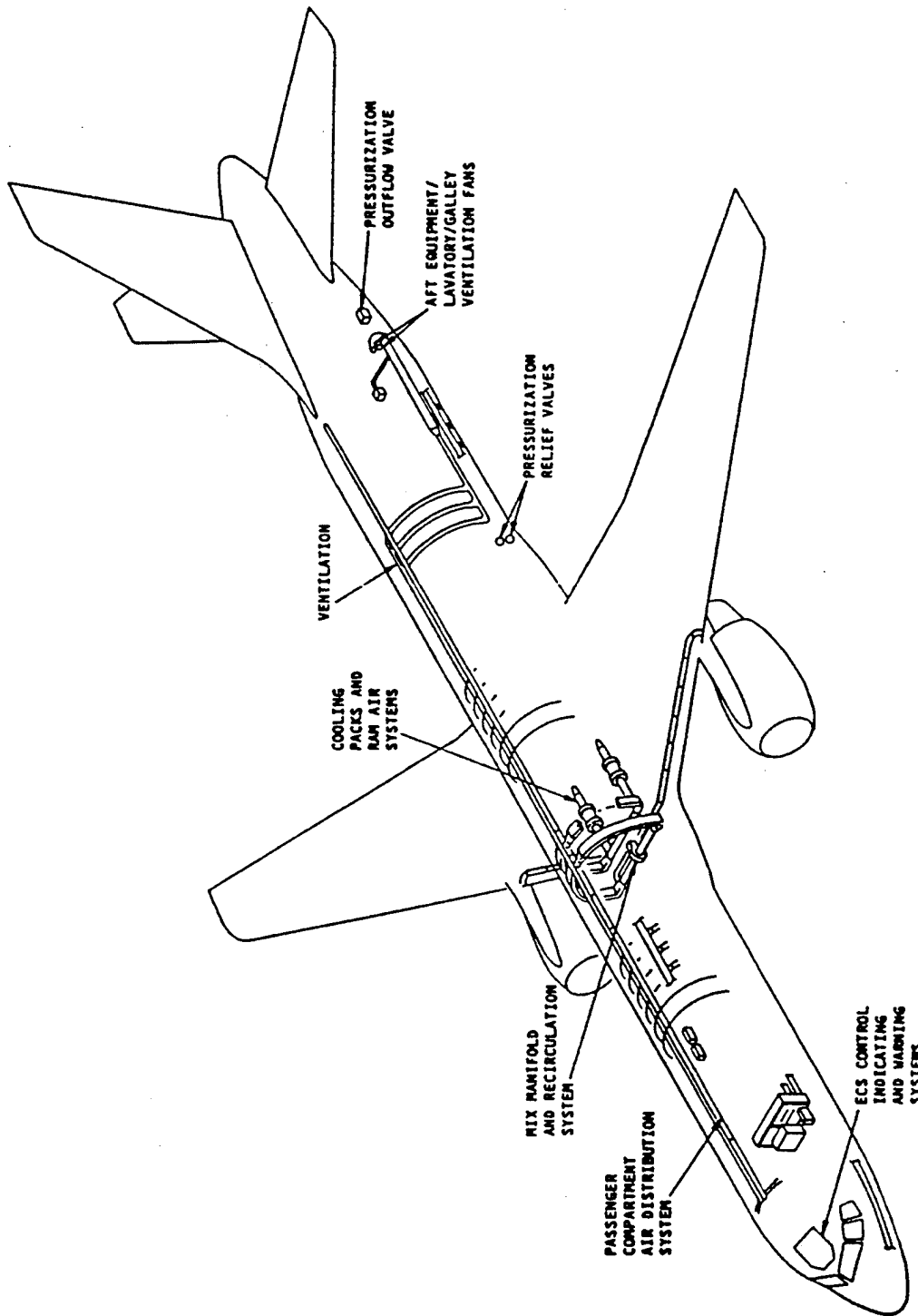

FIGURE 2. ECS SUBSYSTEMS

AIR CONDITIONING. The air conditioning system provides heating and/or cooling air with humidity control at flow rates desirable for commercial aircraft comfort levels as well as air flow required for pressurization and ventilation. It is designed to provide approximately 20 cfm of conditioned air per passenger.

Preconditioned bleed air is supplied to the packs through the pack flow control and shutoff valves which regulate the flow through the system. The temperature and pressure of the hot bleed air are further conditioned and regulated by the ECS before it enters the cabin areas.

The flow control valves control the airflow rate from the pneumatic system to the air conditioning packs. The valves are electro-pneumatic devices which are automatically controlled to provide a constant flow rate to the packs. The flow through the valves is not affected by varying air densities below 22,000 ft. Each flow control valve can provide 165 percent of its normal flow when one pack or the recirculation fans are shut down.

The hot engine bleed air is routed to heat exchangers where it is cooled by ram air before it enters the air cycle machines (ACMs). After compression and expansion in the ACMs, moisture is removed and the air flows to the mix manifold where it is further conditioned before entering the distribution ducting to the passenger cabin. The ACMs, ram air system, and other associated equipment are located in an unpressurized area of the fuselage just forward of the wheel wells.

Conditioned air is distributed to the passenger cabin through two sets of main risers, located approximately between station 839 and station 900, which lead from the mix manifold upwards along the fuselage wall to the main centerline distribution ducts running fore and aft in the fuselage ceiling. The forward set of risers supplies air to the cabin forward of station 865; the aft risers furnish conditioned air to the aft section of the cabin. The air is evenly distributed from the centerline ducts through orifices in a nozzle below the duct and through sidewall droppers which discharge above the window line and at the gasper air outlets. The air flows downward through the cabin and passes into the lower lobe through return air grilles in the sidewalls near the floor line.

Approximately one-half of the conditioned air is recirculated from the return air exhausted into the lower lobe by passing it through filters in the left and right recirculation systems and back into the mix manifold. Electrical/electronic (E/E) equipment cooling air is supplied by the left recirculation system before being routed to the mix manifold or dumped overboard. The aft E/E equipment rack is cooled by the lav/galley vent system. Cargo heating is accomplished by picking up air in the lower lobe and passing it through fans and heaters into the cargo compartments.

Conditioned air is supplied to the flight crew by a separate system through ducting from the left pack directly to the flight deck. If the left pack becomes inoperative, the flight deck is supplied through a crossover feed from the mix manifold.

Figures 3 and 4 show a diagram of the ECS and a schematic of the packs and ram air system.

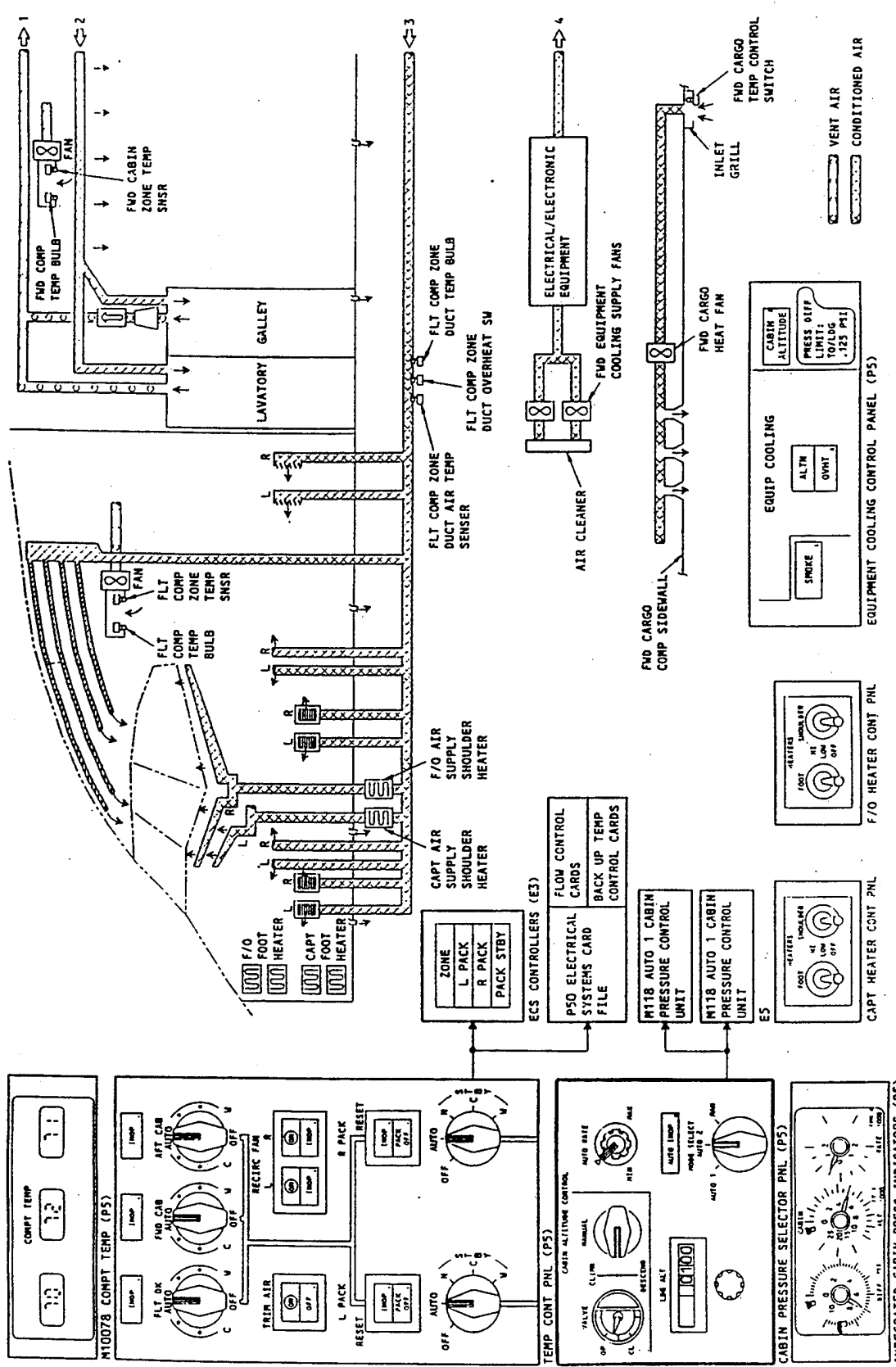

FIGURE 3. ECS DISTRIBUTION

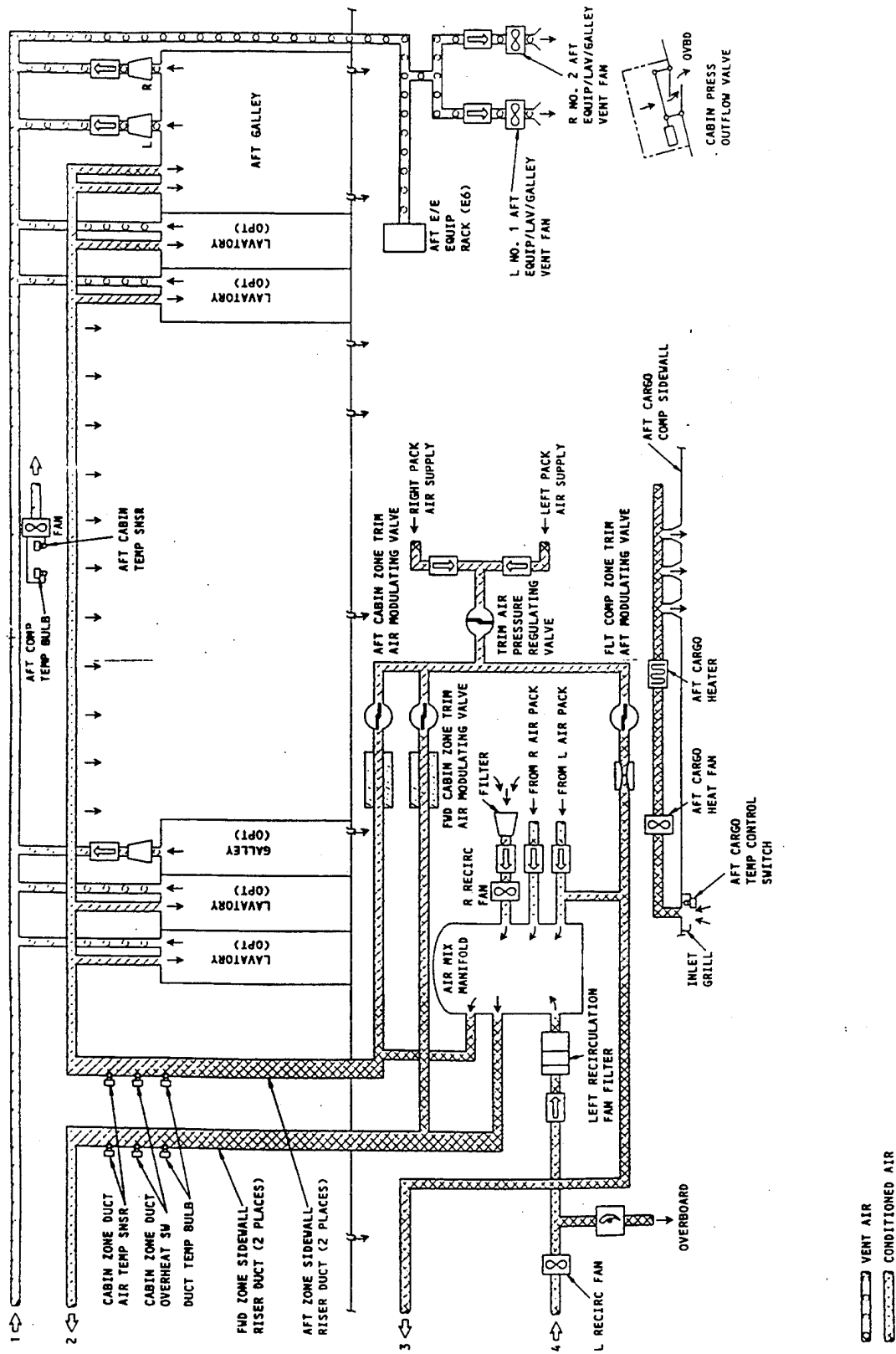

FIGURE 3. ECS DISTRIBUTION (CONTINUED)

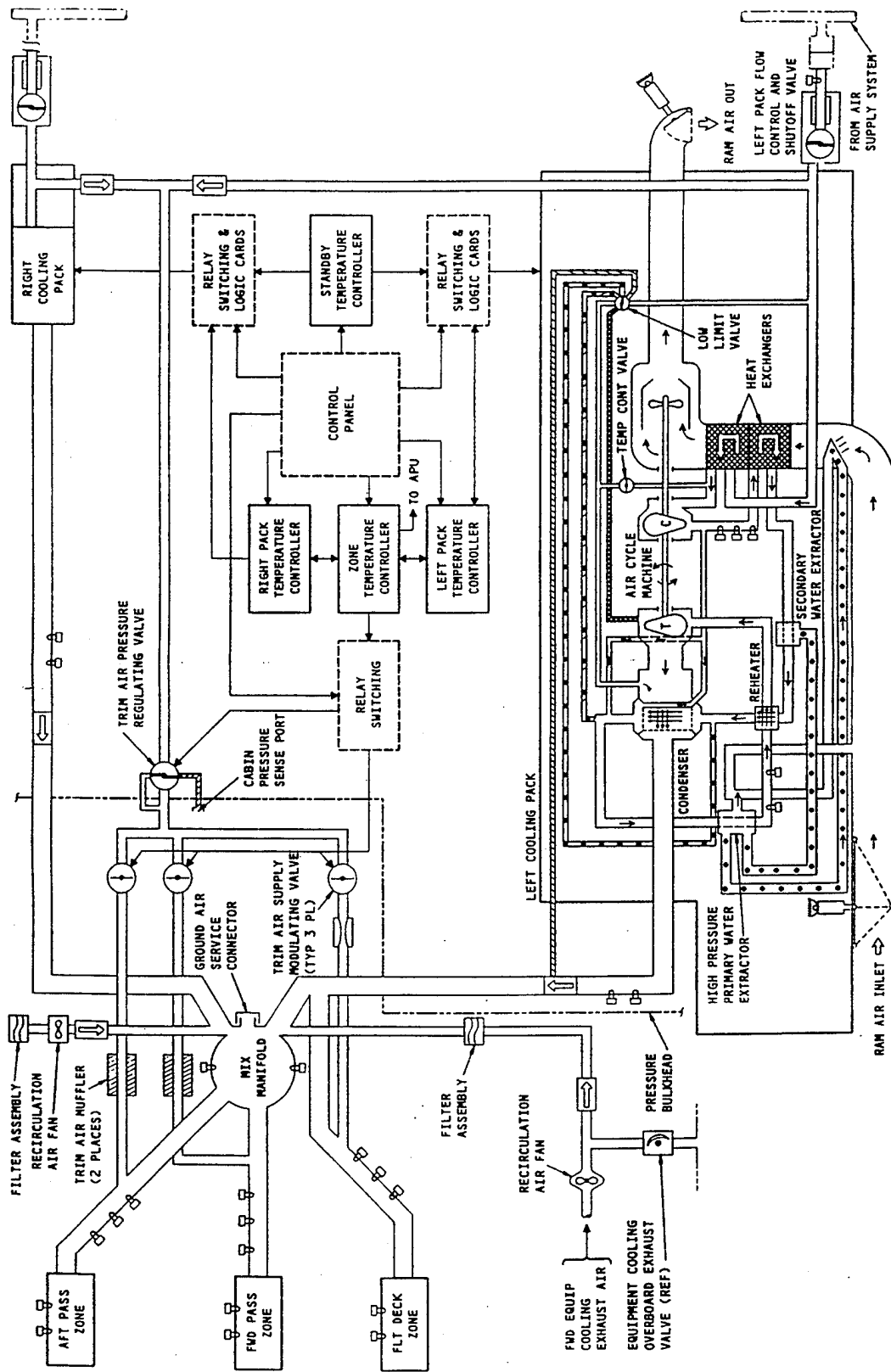

FIGURE 4. ECS SUPPLY

Ventilation of the airplane is accomplished by exhausting the air out of the lower lobe of the fuselage through the modulating outflow valve located on the aft lower left side of the fuselage. Separate galley and lavatory vent systems collect air from these locations and duct it to the lower lobe where it is exhausted near the outflow valve.

The total outflow from the airplane is the sum of the flow through the outflow valve, the equipment cooling overboard dump valve if used, and the leakage throughout the pressurized section of the fuselage.

Table 1 gives the flow rates for conditioned air. Figures 5 and 6 show passenger compartment air distribution and the normal air flow within the cabin.

TABLE 1. B-757 ECS FLOW RATES

Flight Regime	Passenger Cabin - Two Packs With Recirculation		Two Packs @ 165%	Pressures (psia)		
	Total (cfm)	Fresh Air (cfm)	All Fresh (cfm)	Pack Outlet	Cabin Supply	Ambient
Sea level takeoff	3296	1714	2828	15.1	14.7	14.7
5,000 ft. climb	3284	1740	2871	15.1	14.7	12.2
10,000 ft. climb	3251	1690	2789	15.1	14.7	10.1
25,000 ft. cruise	3212	1638	2703	14.4	14.1	5.45
30,000 ft. cruise	3250	1690	2789	13.3	12.9	4.36
35,000 ft. cruise	3711	1670	2756	12.3	11.9	3.46
42,000 ft. cruise	3645	1677	2767	11.3	10.9	2.48
20,000 ft. descent	3682	1730	2855	14.1	13.7	6.75
10,000 ft. descent	3645	1677	2767	14.8	14.3	10.11

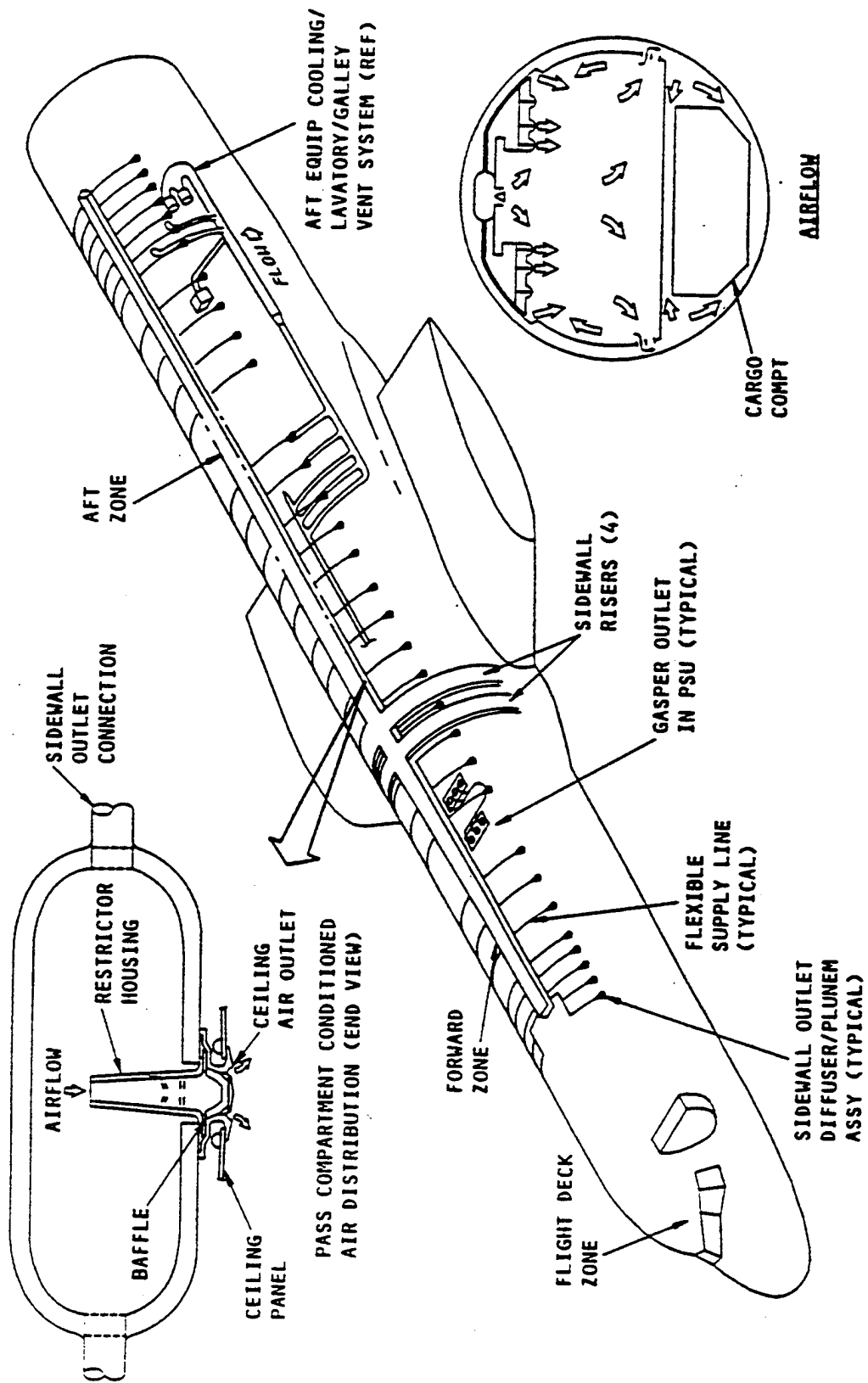

FIGURE 5. PASSENGER COMPARTMENT CONDITIONED AIR DISTRIBUTION

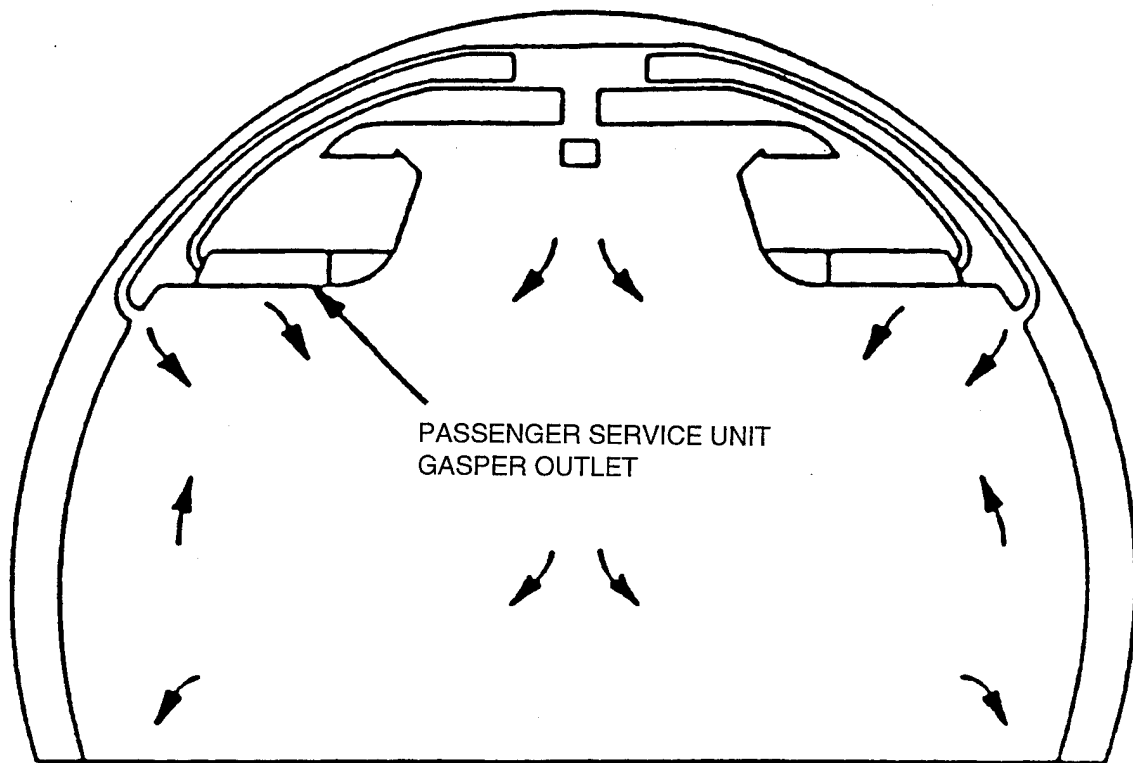

FIGURE 6. NORMAL CONDITIONED AIR FLOW IN CABIN

PRESSURIZATION. The airplane is pressurized by the ECS to maintain a maximum cabin altitude of 8,000 feet. The cabin altitude is maintained by controlling the air flow through the modulating outflow valve by means of an automatic control system. Pressurization also can be controlled manually by the crew when desired. The outflow valve is shown in figure 7.

The pressurization control system consists of the selector panel, two automatic controllers, the outflow valve, air data computers, the pressure relief valves, and the cabin altitude warning switch. The system provides three essentially independent control paths for the outflow valve. The system is normally controlled in one of two separate modes, Auto 1 or Auto 2. Each has a separate power source, separate potentiometer inside the control panel, separate automatic controller with built-in test equipment (BITE) and controls a separate alternating current motor at the valve. A manual mode provides backup capability. Figure 8 is a diagram of the pressurization control system.

The pressurization system contains three backup safety systems. The positive pressure relief valves prevent differential pressure from exceeding structural limits in the event of a pressurization system malfunction. The negative pressure vent doors (relief valves) prevent cabin pressure from becoming less than ambient pressure in the event of an emergency descent. The altitude warning system provides a warning for excessive cabin altitude. These are shown in figure 9.

Pressurization schedules are shown in figure 10.

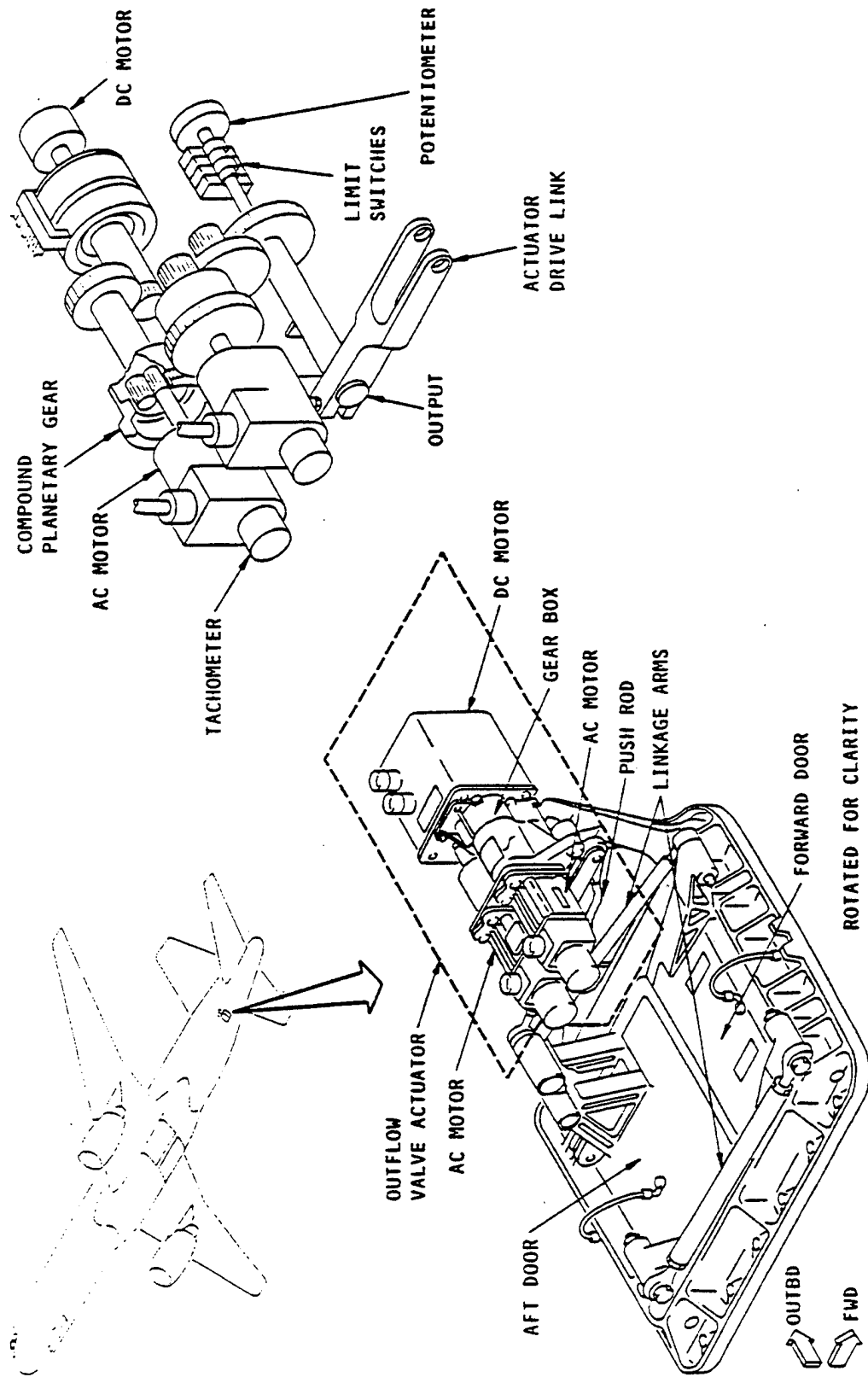

FIGURE 7. CABIN PRESSURE OUTFLOW VALVE

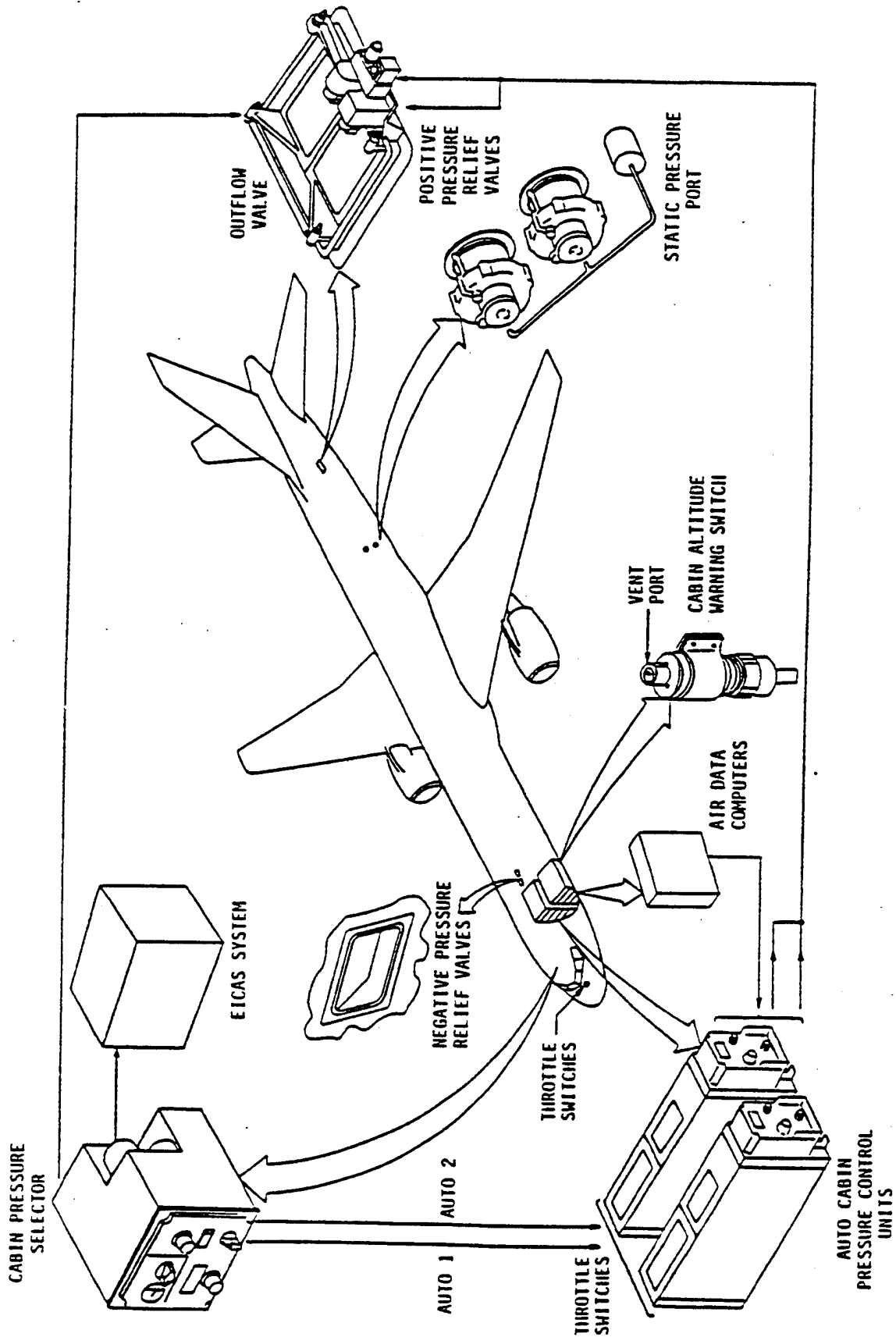

FIGURE 9. PRESSURIZATION CONTROL EQUIPMENT LOCATION

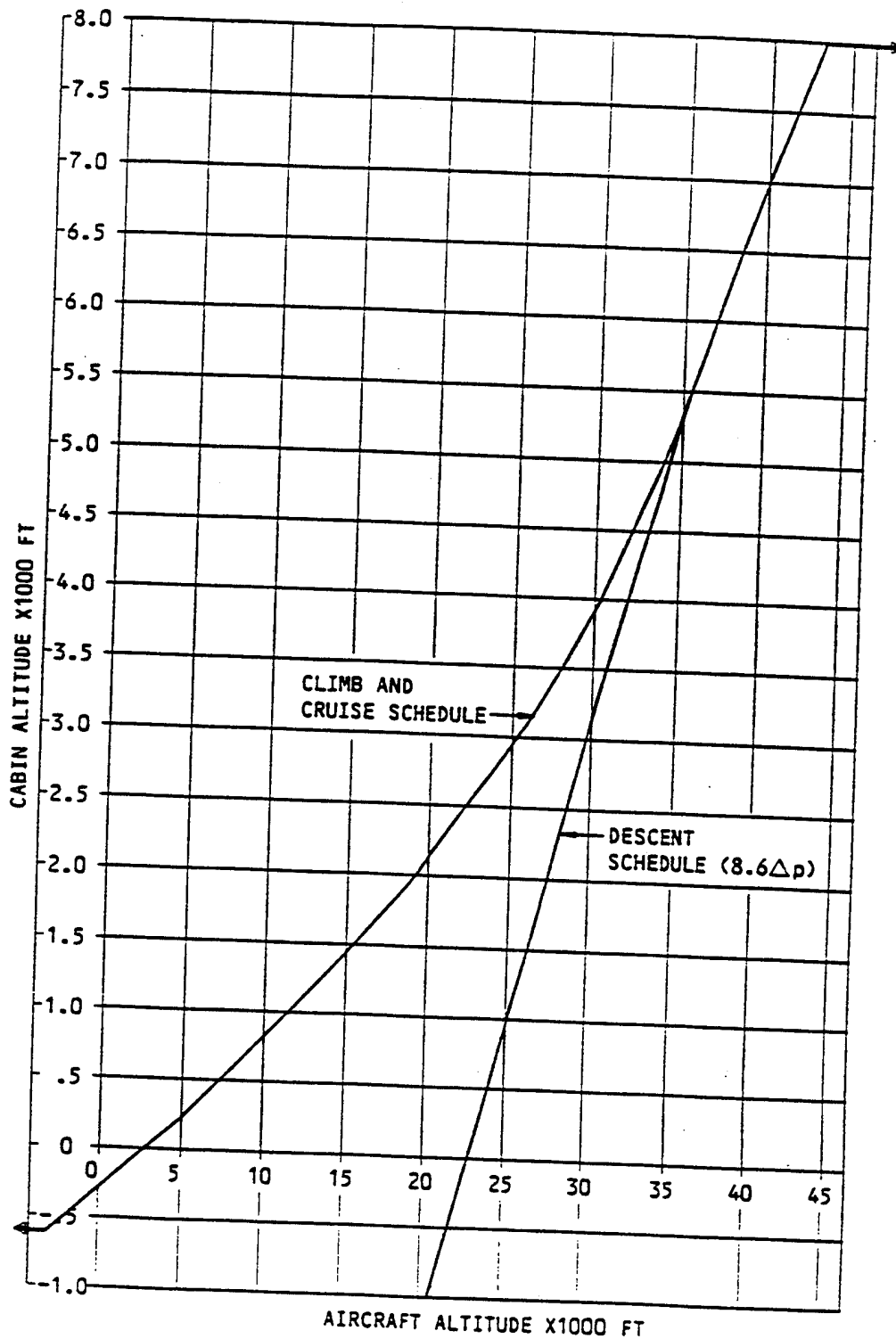

FIGURE 10. AUTO PRESSURIZATION SCHEDULES

CONCEPT 1 FOR IMPROVED SMOKE CONTROL.

DESCRIPTION OF CONCEPT 1—ECS MODIFIED FOR SMOKE CONTROL AND EVACUATION. Concept 1 would provide enhanced control and evacuation of smoke in the cabin through modifications to the ECS and changes in its operation during an emergency. The ECS would continue to perform its air conditioning and pressurization functions while operating in the smoke control mode throughout the emergency. It also would continue to provide a survivable environment for the occupants after the airplane has landed and occupant egress is under way. This would be accomplished by

- Installing two smoke control vents in the upper lobe of the fuselage, one of which would be opened in response to smoke in the cabin. The vents would be similar to the production outflow valve, modified as necessary for installation at these locations, and would perform the pressurization control functions of the outflow valve.
- Modifying the centerline distribution duct such that the total flow of incoming air can be directed to the forward or aft sections of the cabin.
- Modifying the ram air system in order to supply fresh air to the cabin during passenger evacuation after the engines are shut down.

It has been shown by previous tests [3, 4, and 5] and by testimony from the Air Canada accident investigation [6] that smoke resulting from an in-flight fire is strongly buoyant, rising and accumulating at the ceiling, and then spreading laterally and axially throughout the cabin.

The enhanced smoke evacuation study which E. Maylor performed at Boeing in 1987-1988 under contract to the FAA Technical Center contemplated the use of an additional outflow valve located in the forward section of the fuselage and increased pack flow to aid in smoke evacuation [2]. The scheme was to open either the forward or aft outflow valve, both located in the fuselage lower lobe, depending upon where the source of smoke was located.

Maylor developed relationships which evaluated the effectiveness of smoke removal in terms of the length of the cabin which would be smoke free, a parameter which he called LSF, under a variety of conditions. He also considered a second configuration in which fans would be installed in the ram air system to provide a source of fresh air to the cabin when the engines had been shut down during passenger evacuation. A forward "dump valve" in the lower lobe of the fuselage was incorporated in this configuration as well.

The results of this study showed that these modifications would not produce large improvements in smoke evacuation beyond that obtained from normal pack operation. The study contract had an option for a second phase for evaluating the more promising configuration in actual airplane tests. Because the study predicted only marginal improvements in smoke evacuation, the second phase was realigned by the FAA to be a more research oriented flight test program in which other improved methods for smoke control might be uncovered.

Since the study analysis did not specifically consider the buoyant nature of hot smoke, it was concluded that some of the airplane smoke evacuation tests should be restructured to account for

this behavior. Accordingly, it was decided to alter the configuration of the test airplane in an attempt to more realistically simulate actual conditions. The changes included placing the additional forward outflow valve in the upper lobe of the fuselage and adding helium gas to the theatrical smoke to simulate smoke behavior at approximately 450°F.

Several series of tests of this modified configuration were conducted in the Boeing owned B-757. These tests evaluated both buoyant and nonbuoyant smoke evacuation in flight and on the ground using various combinations of smoke source location and outflow valves [3]. The tests showed that the conditions in which smoke removal was most improved were those in which (1) the smoke was buoyant as would be the case in a fire condition, and (2) the forward upper lobe outflow valve was used and the source of smoke was in the forward section of the cabin.

In tests where the production aft lower lobe outflow valve was used, smoke spread throughout the cabin and smoke evacuation was greatly reduced. The smoke also seemed to be strongly affected by the turbulence from the air conditioning outlets in the vicinity of the smoke source causing it to mix and spread through the cabin.

Concept 1 of this study builds on the findings of Maylor's work and proposes additional modifications to the ECS that will produce a higher level of cabin smoke control and evacuation.

OPERATION OF THE MODIFIED ECS IN THE SMOKE CONTROL MODE—CONCEPT 1.

The key elements to improved smoke control and evacuation embodied in Concept 1 are

- The creation of a strong draft of fresh air axially through the cabin towards an open vent.
- The elimination of local turbulence in the section of the cabin where the smoke source is located, thereby reducing mixing and dispersion of the smoke throughout the cabin.

While in the smoke control mode, the ECS would continue to provide fresh air flow to the cabin and flight deck and maintain aircraft pressurization. This would be accomplished by opening an upper lobe vent in the section of the cabin containing the smoke source and redirecting the flow in the centerline duct to the section of the cabin which does not contain the smoke source. The absence of flow from the centerline nozzle and sidewall droppers in the section of the cabin where smoke is being generated will prevent stirring and dispersion of the smoke as it rises to the cabin ceiling and will contain the smoke in that section of the cabin. By causing the total flow of the ECS to be directed from the opposite end of the cabin and opening the vent in the section containing smoke, a pressure differential would be created from the area which is smoke free to that of high smoke concentration. The result will be a draft of conditioned air in the direction of the open vent, preventing smoke from migrating to the rest of the cabin and exhausting it through the vent.

Upon discovery of smoke in the cabin of the airplane, an assessment of the location of its source must be made by the crew i.e., forward or aft cabin. If the determination is made that a critical condition exists, the ECS would be placed in the smoke control mode and the ECS control system would cause either the forward or aft upper lobe vent to open, depending upon the location of the smoke's source. Passengers would be relocated to the section of the cabin which

is free from smoke. Control of cabin pressurization would be transferred from the lower lobe outflow valve to the active upper lobe vent. As the airplane begins a rapid descent, the upper lobe vent would control the cabin altitude in the same fashion as the production lower lobe valve would under normal conditions.

The selection of one of the upper lobe vents also causes one of the two valves installed in the centerline distribution duct to close. Selection of the forward vent causes the forward centerline duct valve to close; selection of the aft vent causes the aft centerline duct valve to close. Both trim air valves would also close. When either centerline duct valve is closed, the total flow through the duct goes to the opposite section of the cabin. The effect is to unbalance the distribution flow with the following results:

- Conditioned air would enter the smoke-free section of the cabin at its normal volume but at higher velocity since the total flow would be exhausted through only part of the nozzle and droppers.
- Stirring and dispersion of the smoke, as it rises to the ceiling in the section of the cabin where the source is located, would be reduced because of the absence of flow from the nozzle and sidewall ducts in this section.
- The flow within the cabin no longer would be down from ceiling to floor because the lower lobe outflow valve is closed and the flow would become axial through the cabin towards the open upper lobe vent.

For example, if the smoke source were located in the forward cabin, the forward outflow valve would be opened and the forward centerline duct valve would be closed. This would cause the flow in the duct to stop forward of station 860 and to be diverted to the aft section of the cabin. The total flow would enter the cabin aft of station 860 and would then flow forward towards the open outflow valve. Similarly, smoke sources in the aft cabin would cause the aft centerline valve to be closed, directing the flow in the centerline duct into the forward section of the cabin where it would be driven through the cabin towards the open aft vent. The result would be to contain and exhaust the smoke from the section of the cabin near its source while maintaining a smoke-free environment in the rest of the cabin.

When the ECS is operating in the smoke control mode, both recirculation fans would be shut down, preventing smoke-laden air from being recirculated into the cabin. With the recirculation system shut down, the flow control valve automatically would go into high flow mode, increasing the flow to the packs to 165 percent of normal.

After the airplane has landed and the engines are shut down during passenger evacuation, fresh air would be taken from the ram air inlet ducts and diverted through ducting to the mix manifold by battery powered blowers.

Figures 11 and 12 illustrate flow for normal ECS operation and the predicted smoke control and evacuation for Concept 1.

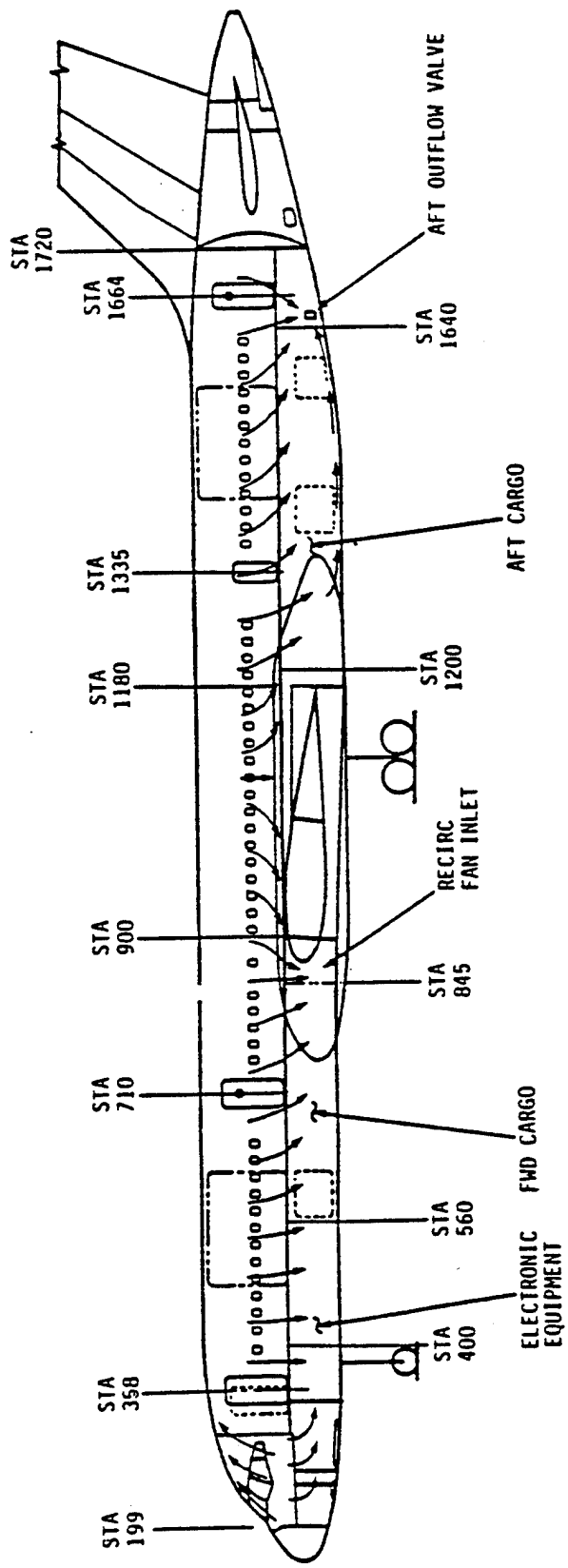

FIGURE 11. NORMAL ECS FLOW

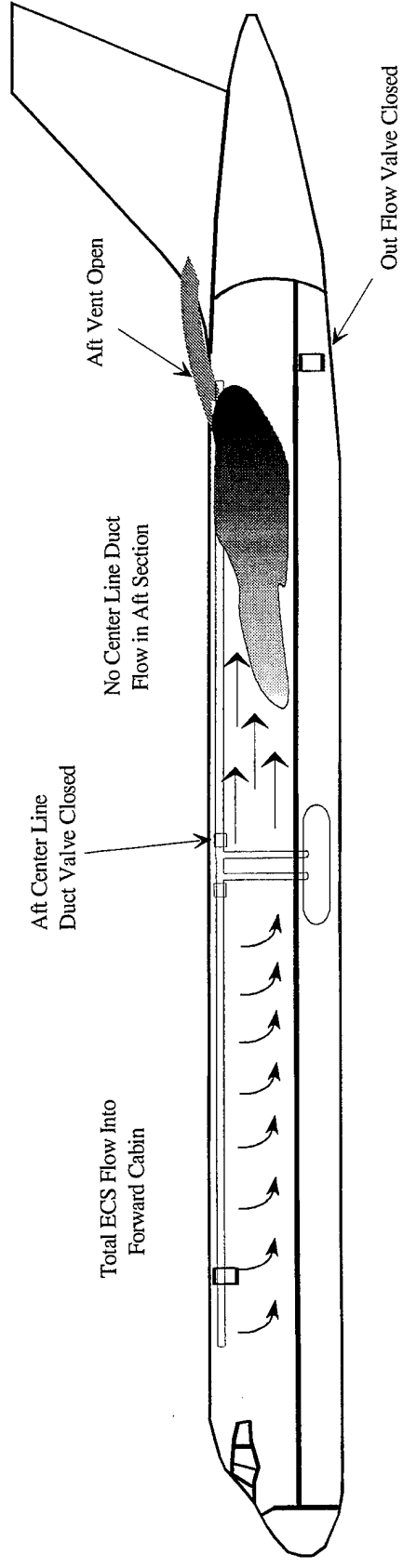
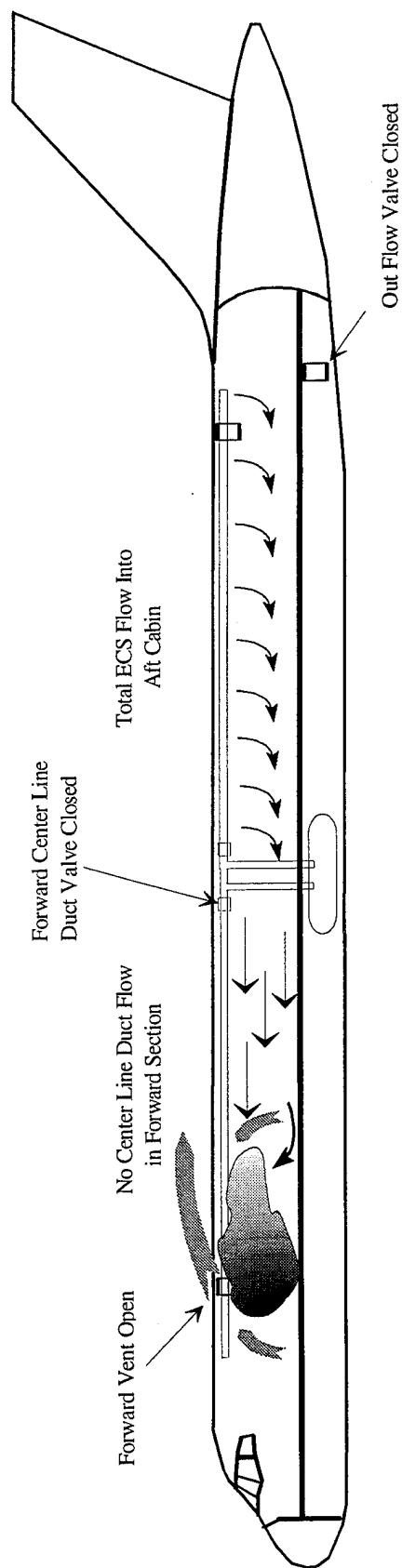

FIGURE 12. ECS FLOW IN SMOKE CONTROL MODE—CONCEPT 1

ECS MODIFICATIONS REQUIRED FOR CONCEPT 1. Smoke Vents: The proposal for this study suggested the installation of three upper lobe vents for smoke control and evacuation. During the course of the study, it became apparent that the system would become substantially more complex if a midcabin vent were used since significant changes to the distribution ducting would be required. In addition, it is believed that only marginal, if any, improvement in smoke evacuation would result over that obtained with forward and aft vents only. For this reason, Concept 1 was developed using two upper lobe vents.

The vents would be similar to production outflow valves, having the capability for modulating operation but with modified mounting hardware for the upper lobe installation. They would be designed to provide a positive, nonleaking seal when closed to prevent moisture infiltration and to eliminate whistling due to air escape when the aircraft is pressurized. In addition, they would be designed to present a smooth aerodynamic surface and not be subject to snow or ice accumulation when closed. In the interior of the airplane, the vents and actuating mechanisms would be housed in enclosures such as dummy stow bins with fixed grilles to prevent passengers, crew or foreign objects from coming into close proximity.

The two vents would be installed approximately at fuselage stations 500 and 1500 as near the crown of the fuselage as possible. The exact locations would be determined by requirements that they be in the constant section of the fuselage in an area where aerodynamic pressure would not inhibit outflow and where minimum changes to existing structure and systems would be required. However, certain structural modifications to the fuselage shell will be required wherever the vents are located.

Figure 13 shows the constant section of the fuselage and the approximate locations for the smoke vents. Aerodynamic data for the B-757 furnished by Boeing indicate that the pressure coefficients along the outside of the fuselage in the section under consideration are zero or negative in these areas. Although these data are for cruise conditions at 35,000 ft, $M=0.80$, standard conditions, and a 2.25-degree angle of attack, it is believed that positive aerodynamic pressure at these locations will not occur in descent. This is supported by the fact that the upper lobe valve in the airplane tests referred to earlier was located at Sta 490, RBL 55.1, WL 281.9 and it performed well.

Vent Controls: The vents would be controlled by the production pressurization control system which would be modified to place the new upper lobe vents in parallel with the lower lobe outflow valve. In the smoke control mode, pressurization control would be transferred from the lower lobe valve, which would be fully closed and de-energized, to the upper lobe vent chosen for smoke control. The upper lobe vents would operate in either auto or manual mode in the same fashion as the lower lobe outflow valve.

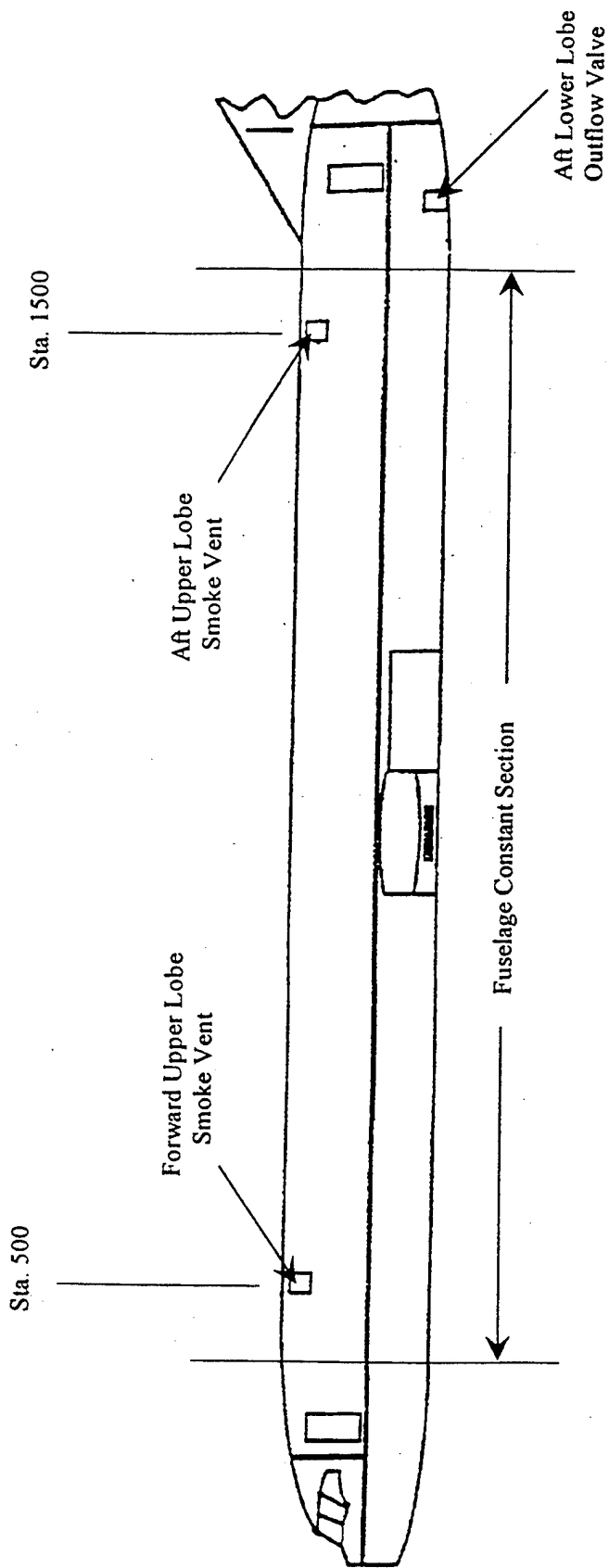

FIGURE 13. SMOKE VENT LOCATIONS

Distribution Ducting: Most of the air conditioning ducting in the B-757 is made from lightweight composite materials, principally fiberglass/epoxy or Kevlar (aramid)/epoxy and in some locations it is insulated.

In September 1993, Boeing changed the centerline duct on the B-757 from its original elliptical configuration, (figure 14) to the current configuration shown in figure 15. The new configuration consists of two circular ducts mounted side by side that reduce in diameter as they progress forward and aft from the supply risers. These ducts distribute fresh air into a plenum located between and below them containing the centerline nozzle and also into the sidewall droppers.

The air conditioning ducting would be modified for Concept 1 by the installation of valves in the centerline distribution duct forward and aft of the risers (figure 16). The valves would be solenoid operated, nonmodulating butterfly valves which would remain fully open during normal operation of the ECS. During operation in the smoke control mode, the selected centerline duct valve would go to the fully closed position while the other remains fully open as previously described.

Ram Air System: The proposal for this study contemplated using exhaust fans installed in interior stowage bins as a means of providing smoke ventilation during passenger evacuation after the airplane has landed. Further review of this concept indicates that blowers providing fresh air would probably turn out to be more efficient than exhaust fans. Accordingly, Concept 1 includes the use of blowers in the ram air system rather than exhaust fans.

It should be pointed out that no modifications to the ram air system would be required for Concept 1 if emergency procedures were revised to call for either leaving one engine running or starting the APU to provide air to the packs during passenger evacuation. However, for the purposes of the study, it was assumed that this would not be the case and no bleed air would be available to the packs once the airplane has been stopped.

The ram air system would be modified to incorporate valved ducting from the ram air inlet ducts to the mix manifold. Forced air blowers would be installed in these ducts to augment the fresh air supply to the distribution system and to furnish air to the cabin when the engines are shut down.

The blowers would be 2.7 kW DC units similar to those proposed by Maylor [2] and would have 8-in.-diameter shutoff valves associated with them. Together the blowers would be capable of providing approximately 3860 cfm of air flow with the airplane stopped at sea level.

The blowers could be started after the airplane is depressurized during descent and would shift to battery power upon engine shutdown. Figure 17 shows the ram air system and the proposed modifications.

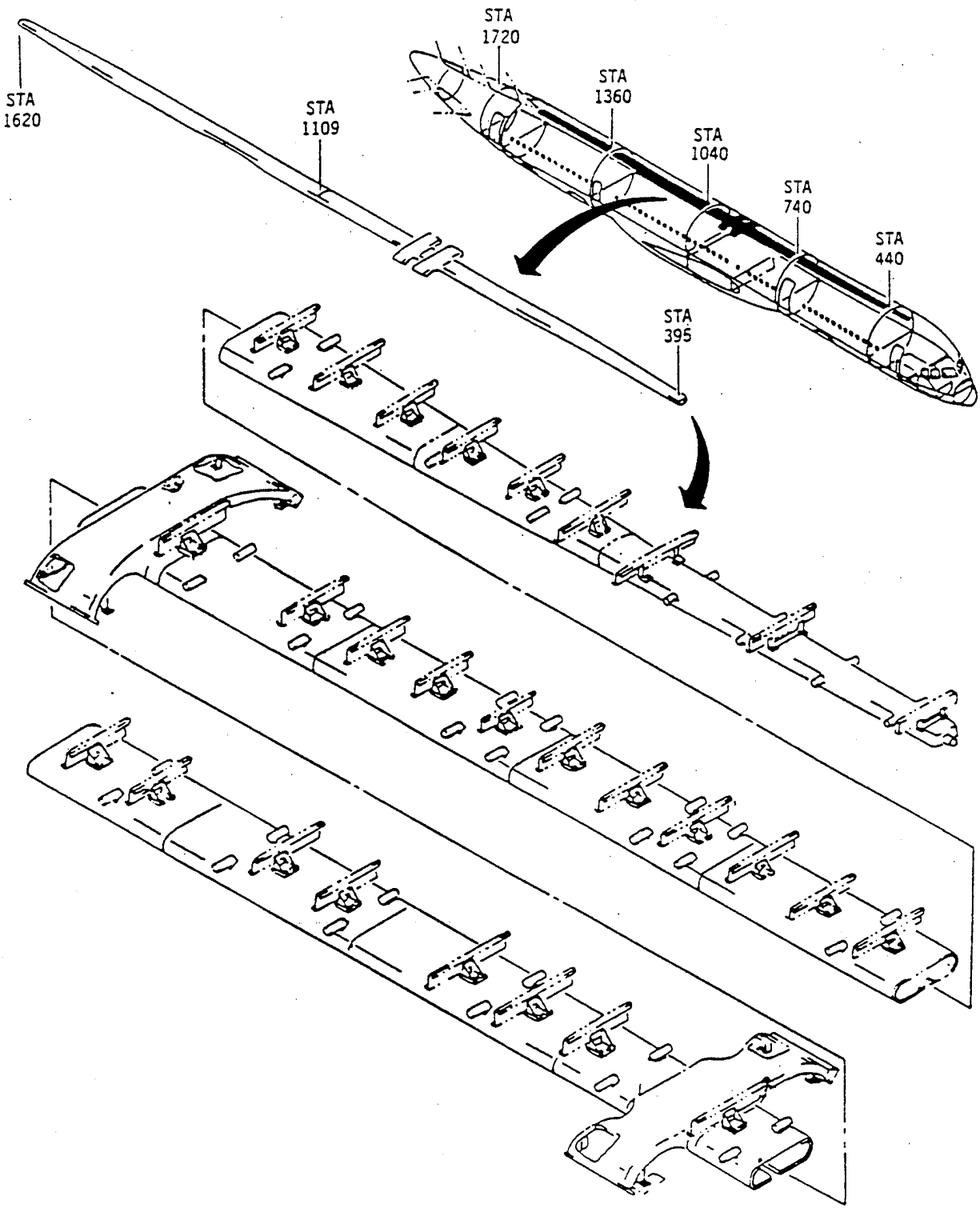

FIGURE 14. ELLIPTICAL CENTERLINE DUCT CONFIGURATION

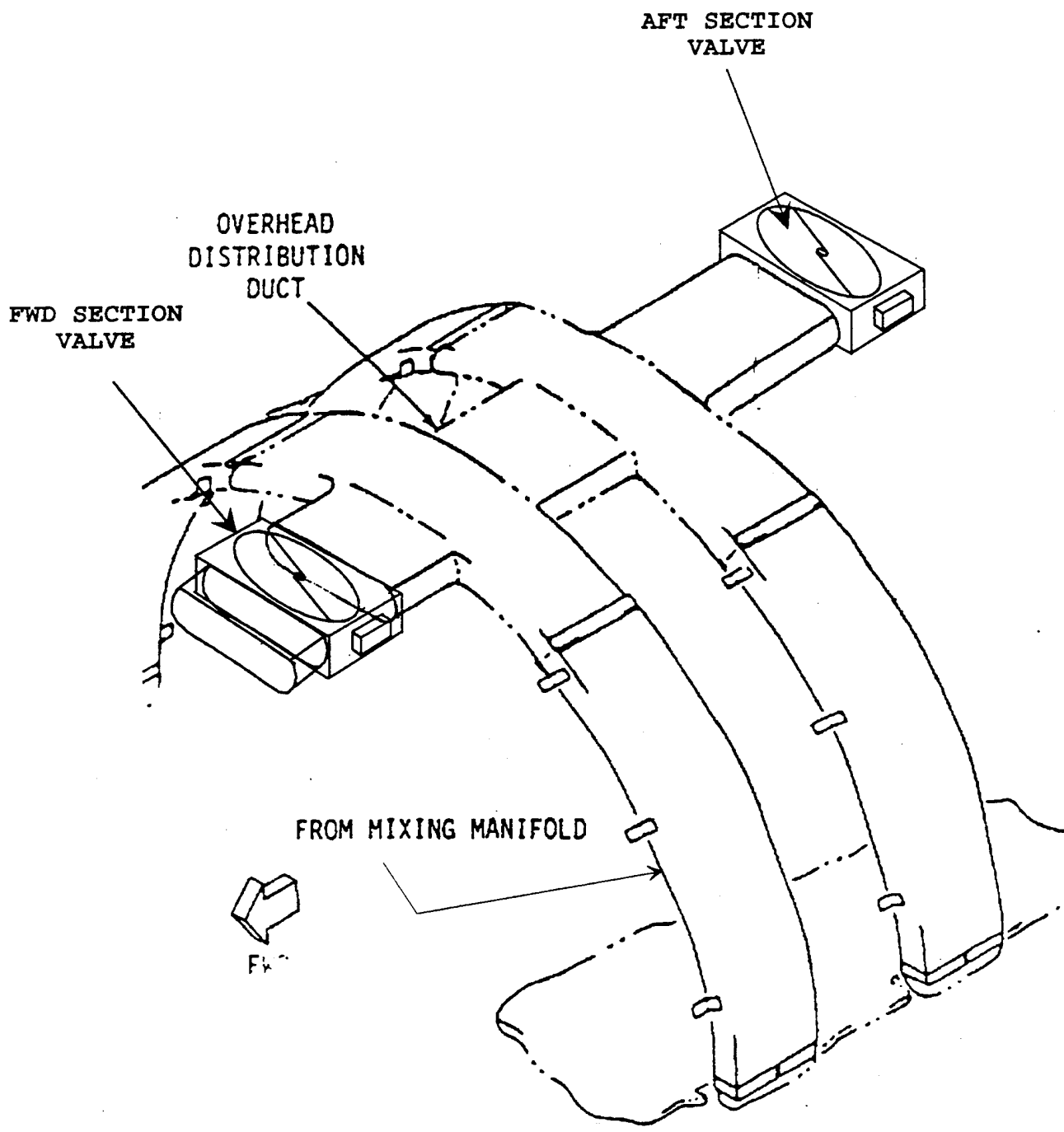

FIGURE 16. VALVES INSTALLED IN CENTERLINE DISTRIBUTION DUCT (TYPICAL, BOTH DESIGNS)

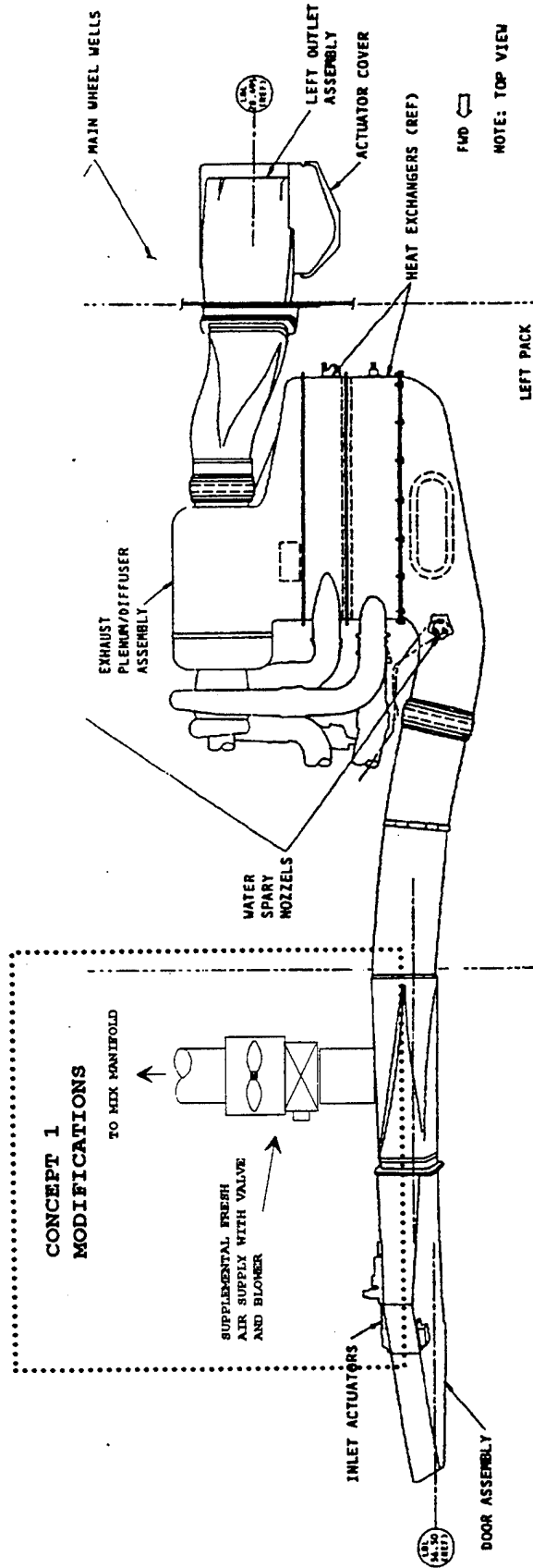

FIGURE 17. RAM AIR MODIFICATIONS

PERFORMANCE ASSESSMENT OF CONCEPT 1. When the ECS is put into the smoke control mode, the outflow changes from the lower lobe outflow valve to the upper lobe smoke vent. The recirculation fans are shut down to prevent smoke from being recirculated back into the cabin and when this occurs, the flow control valves automatically go into high flow mode (165 percent of normal). Although the total flow into the cabin is reduced somewhat because of the lack of recirculated air, it is all fresh air and it is all exhausted overboard. For example, from table 1 it can be seen that at 30,000 ft. the flow of fresh air to the cabin increases from 1690 cfm to 2789 cfm under these conditions.

The difference in the two modes of operation and the increased capability to exhaust smoke come from the manner in which the air flows through the passenger cabin and the fact that none is recirculated.

When the air conditioning is operated in its normal mode, the flow of air in the cabin is downwards from the ceiling and side walls above the window line, towards the return air grilles at floor level, and into the lower lobe. ECS engineers have taken great pains to design the system to assure uniform air distribution along the length of the cabin and to provide the flow at passenger head level at a velocity of no greater than 50 ft/min. They have achieved this through careful design of the plenum and nozzle of the centerline duct and the sidewall outlets.

Local velocities within the cabin are much greater however. The exit velocity at the nozzle orifices is about 700 ft/min., reducing to 200-300 ft/min. 10 inches from the nozzle. The exit velocity of the side wall droppers is also around 700 ft/min. and drops to between 125 and 200 ft/min. 25 inches away from the side wall and 1 inch down.

When smoke is produced anywhere in the cabin, it tends to rise due to its buoyancy, becomes mixed with the general airflow due to the stirring effects of the nozzle and side wall dropper flows, and spreads laterally and axially to generally fill the cabin. If enough smoke is generated, this mixing and dispersion action overcomes the ability of the ECS in normal flow to exhaust it, the concentration rises to hazardous levels, and visibility is reduced to the point of obscurity throughout the cabin.

In the smoke control mode, the flow through the cabin would be significantly altered such that no air would flow down into the lower lobe of the fuselage from the floor level return air grilles but instead would flow axially through the cabin toward the open outflow smoke vent. In the cabin section where smoke is being generated, no high velocity flows would exist from the distribution system. The axial flow would be essentially unrestricted from floor to ceiling in the aisle and in the zones between the passengers' heads and the bottoms of the stowage bins. Elsewhere it may form eddies as it flows over and around obstructions; however, the general movement of air and smoke would be to the open vent.

Furthermore, there likely would be a velocity gradient from floor to ceiling with the highest flows occurring nearer the ceiling and under the stowage bins. Smoke generated and rising in the path of the moving air, but not being stirred by turbulence from the distribution system, would be prevented from migrating back through the cabin and would be carried out the open vent.

As the airplane descends, the ECS would continue to operate in the smoke control mode in order to maintain a survivable environment in the cabin. Once the airplane has landed and come to a stop, the ram air blowers will have switched to battery power to supply fresh air to the cabin after the engines have been stopped. The airplane tests which the FAA and Boeing conducted showed that as soon as any doors were opened, smoke immediately began to move towards the open doors, and it would be essential to maintain an adequate fresh air inflow to the cabin. The blowers would have to operate on battery power for approximately 90 seconds since commercial transports must demonstrate that passenger evacuation can be accomplished within this time in order to be certified.

IMPLICATIONS OF CONCEPT 1 MODIFICATIONS. Since the number of occurrences of serious smoke incidents in commercial transports is low, the ECS in a given airplane would rarely be called upon to operate in the smoke control mode. Therefore, changes to it for smoke control purposes should neither compromise its normal operation nor produce unwanted side effects.

Concept 1 would not affect the normal operation of the ECS. There may be slight pressure losses in the distribution ducting due to the new valves but these should be quite small.

In the smoke control mode, shutting off the flow through one section of the centerline duct would result in a slight pressure rise in the rest of the distribution system. The magnitudes of the increased pressure has not been calculated, but it is expected to be small. The air conditioning system operates at very low pressures and the ducting and mix manifold are of sufficient strength to withstand substantially higher internal pressures than will be encountered in any event.

Of possible concern is adequate electrical/electronics equipment cooling when the ECS is in the smoke control mode due to lack of air flow in the lower lobe. If this becomes significant, provisions will have to be made to divert cooling air for this purpose.

Concept 1 would require changes to various systems within the airplane. These include structural modifications to the fuselage shell in the areas of the smoke vents, modifications to the ECS distribution ducting including the installation of valves, changes to the ECS control system logic and hardware, electrical modifications, modification of the ram air system to include valves and ducting to the mix manifold, and modifications to the airplane interior in the areas of the smoke vents.

These changes will entail nonrecurring efforts for design, analysis, tooling, tests and certification as well as recurring costs for each airplane. Estimates of these costs will require detailed analyses of the changes which are beyond the scope of this study.

The weight penalty for hardware associated with Concept 1 is expected to be small, probably less than 200 lbs. The following table gives estimated weights for components required for Concept 1.

TABLE 2. ESTIMATED WEIGHTS—CONCEPT 1

Component	Quantity Required	Estimated Total Weight (lbs)
New Outflow Valves	2	40
Structural Reinforcement	2	32
New Ducting	lot	15
Centerline Duct Valves	2	12
Ram Air Inlet Valves	2	10
Ram Air Inlet Blowers	2	36
Valve Controls	lot	6
Additional Electrical Wiring	lot	10
Interior Furnishings	lot	20
Miscellaneous Hardware	lot	15
Total		196

Parasitic drag due to the two additional vents in the fuselage can be kept to a minimum with good design.

The degree of difficulty in installing the ducting changes will require a more detailed assessment of space constraints.

ELEMENTS REQUIRING FURTHER STUDY. Technical issues associated with Concept 1 requiring further study include:

- Detailed design and analysis of the smoke vent locations and the required structural modifications to the fuselage shell.
- Interior modifications to hide and restrict access to the smoke vents.
- Further analysis of the flow in the distribution system.
- Designs of the distribution valves, smoke vent valves, and the pressurization control system.
- Effects on avionics equipment cooling by lack of lower lobe air flow in the smoke control mode.
- Ram air modifications including design and analysis of the blowers, valves, and ducting.

CONCEPT 2 FOR IMPROVED SMOKE CONTROL.

DESCRIPTION OF CONCEPT 2—REVERSED ECS FLOW. In Concept 2, the ECS would be modified such that in the smoke control mode the flow of fresh air within the cabin would be reversed and the cabin distribution ducting would be utilized as a wide area smoke collection system. Concept 2 would also include blowers in the ram air system to supply fresh air after the engines are shut off.

The normal conditioned air flow pattern shown earlier in this report is from ceiling to floor and is essentially uniform along the length of the cabin. In this situation, the incoming air from the centerline nozzle and sidewall diffusers tends to stir the smoke accumulating near the ceiling and under the stowage bins, dispersing it throughout the cabin.

In Concept 2, the flow would be reversed so that conditioned air from the packs would enter the cabin at floor level and flow from floor to ceiling. Smoke, rising naturally due to its buoyancy, would be carried by the incoming air and collected near the ceiling. Since flow in the cabin is reversed, the ECS distribution ducting would function as the exhaust system and the total flow through the cabin would enter the distribution outlets in the upper levels of the cabin to be conveyed by the centerline duct and exhausted overboard through a new outflow valve.

The spread of smoke would be reduced by the absence of stirring from the distribution outlets and the reversed flow of fresh air would tend to concentrate most of the smoke and toxic gases above the heads of the occupants enhancing survivability in the lower part of the cabin. Sub-scale tests also have shown that reversing the flow of air from floor to ceiling tends to lower ceiling temperatures [5] reducing the risks of flashover.

OPERATION OF THE MODIFIED ECS IN THE SMOKE CONTROL MODE—CONCEPT 2.

The key elements of Concept 2 are

- Reversing the direction of fresh air flow within the cabin from floor to ceiling.
- Utilizing the ECS distribution system to collect smoke and convey it through the centerline duct to a new outflow valve.

In Concept 2, the flow of fresh air within the cabin would be reversed by directing the output from the mix manifold directly into the lower lobe rather than into the supply risers. When the crew commands the ECS to enter the smoke control mode, new valves in the mix bay ducting would cause the fresh air to flow into the lower lobe. The air then would enter the cabin at floor level through the return air grilles and travel upwards through the cabin into the centerline duct and through the nozzle and sidewall diffusers. After entering the centerline duct, the smoke laden air would be vented overboard through a new outflow valve.

The new outflow valve would be directly connected to the centerline duct through valved ducting so that the smoke exhaust system would be isolated from the rest of the airplane. With the ECS in the smoke control mode, the normal lower lobe outflow valve would be de-energized in the

closed position and pressurization control would shift to the new outflow valve as in Concept 1. The recirculation system would be turned off as in Concept 1.

Unlike Concept 1, Concept 2 would not be dependent upon the location of the source of smoke since reverse flow from floor to ceiling would exist throughout the cabin. Figure 18 shows the reversed ECS flow in the cabin and figure 19 shows the collection and exhaust scheme.

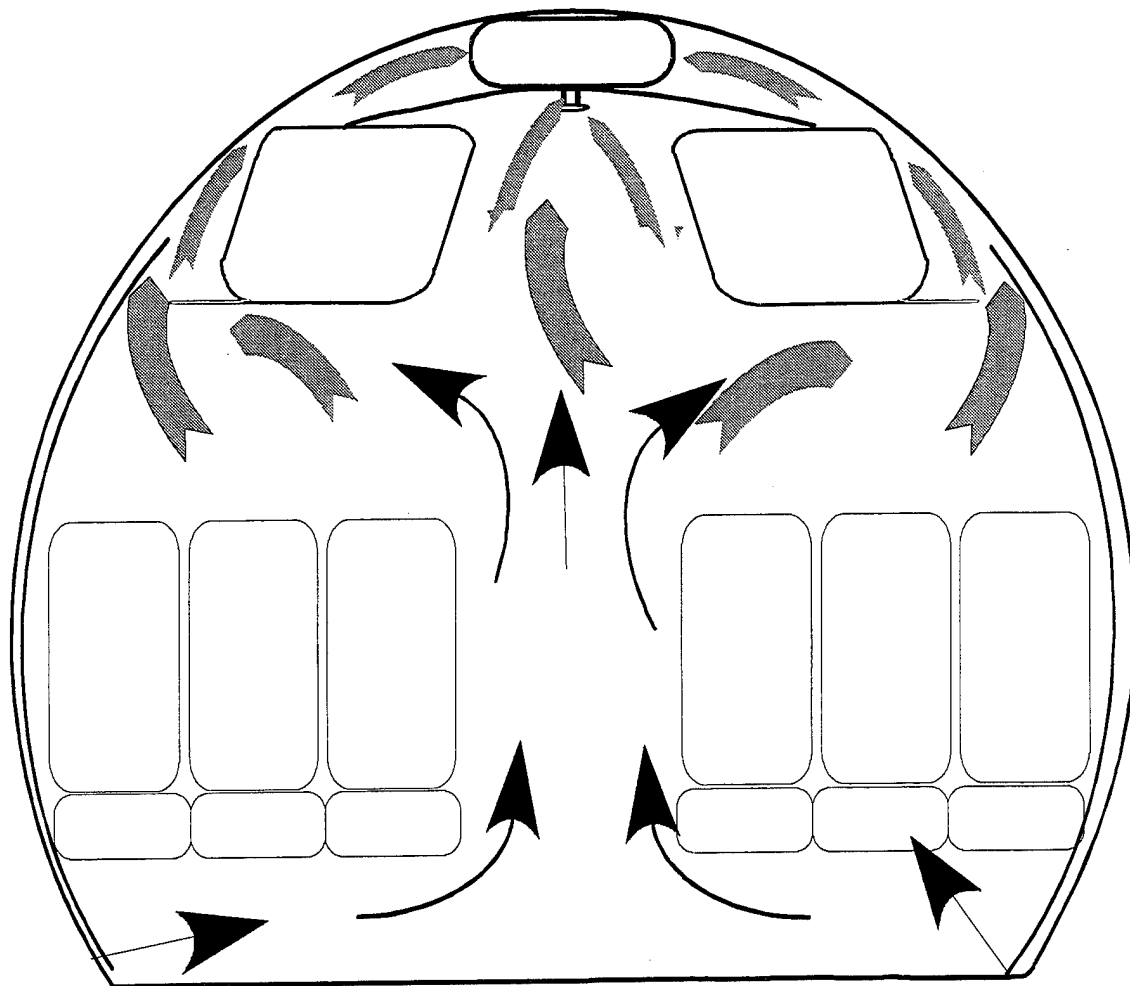

FIGURE 18. CONCEPT 2—REVERSED FLOW IN THE CABIN

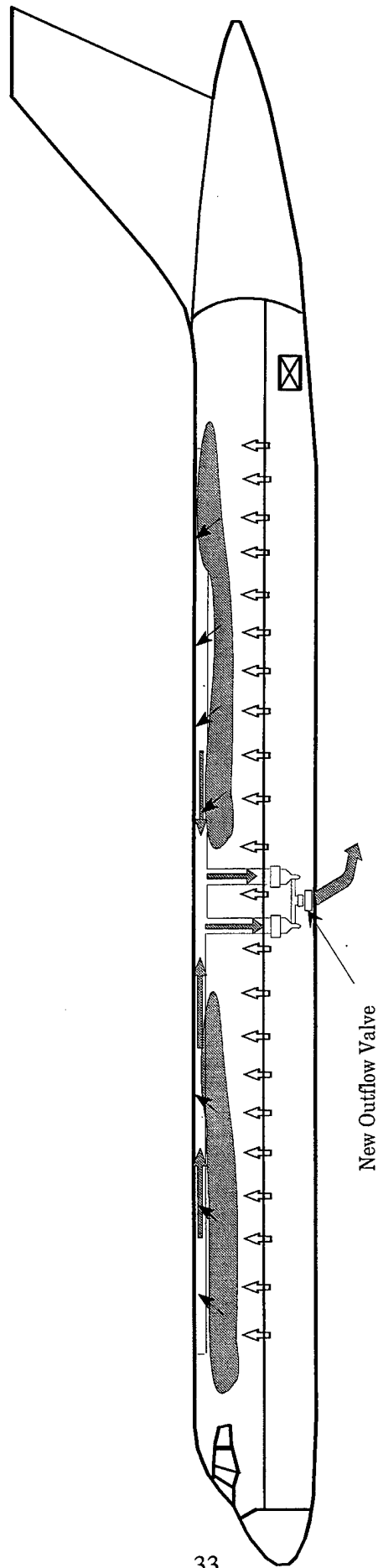

FIGURE 19. CONCEPT 2—SMOKE COLLECTION AND EXHAUST IN REVERSED FLOW

ECS MODIFICATIONS REQUIRED FOR CONCEPT 2. The modifications to the ECS required for Concept 2 include changes to the mix manifold and riser ducting, the addition of duct valves and their controls, changes to the pressurization control system, the installation of a new outflow valve, and the installation of blowers in the ram air system.

In order to redirect the flow, it will be necessary to divert the air leaving the mix manifold so that it can enter the upper lobe near the cabin floor. This would be accomplished by installing valves in the supply ducts from the mix manifold upstream of where they transition to the rectangular risers. These valves would prevent the fresh air from entering the risers and instead divert into the pressurized portions of the lower lobe.

Even distribution of the fresh air into the cabin may present difficulties. The most uniform distribution would be obtained if the fresh air were to flow into ducts running fore and aft below the floor beams which contain outlets near the return air grilles. Installation of this ducting would be complicated by space constraints and provisions must be made for routing the ducting from the mix bay, which is forward of the wheel wells and wing box, to the lower lobe aft of the wing.

Another option would be to exhaust the air directly into the lower lobe in the vicinity of the mix bay and allow it to free flow forward and aft between the wheel well ceiling bulkhead and the wing box into the aft cargo compartment.

Air would flow up into the cabin under the influence of the same small pressure differential which drives the conditioned air flow in normal operation.

The study considered several solutions to the air/smoke exhaust problem. One possibility would be to use the supply risers to the centerline duct to convey the air/smoke mixture down to a new lower lobe outflow valve near the mix manifold.

Another possibility would be to use dropper ducts similar to the supply risers to connect the aft end of the centerline duct with a new outflow valve in the aft lower lobe. The droppers would be installed down the sides of the upper lobe behind the sidewalls in the same fashion as the supply risers.

A third method would be to install the new outflow valve in the upper lobe and connect the centerline duct to it by means of a new short valved duct.

The first method was selected since it would not require modifications to the interior of the cabin and would make use of existing ducting. Figure 20 is a schematic diagram of the ducting and valves for Concept 2.

The modifications to the ram air system for fresh air supply after the engines are shut off would be identical to those for Concept 1 and therefore will not be described here.

Center Line
Distribution Duct

ECS in Normal Operation

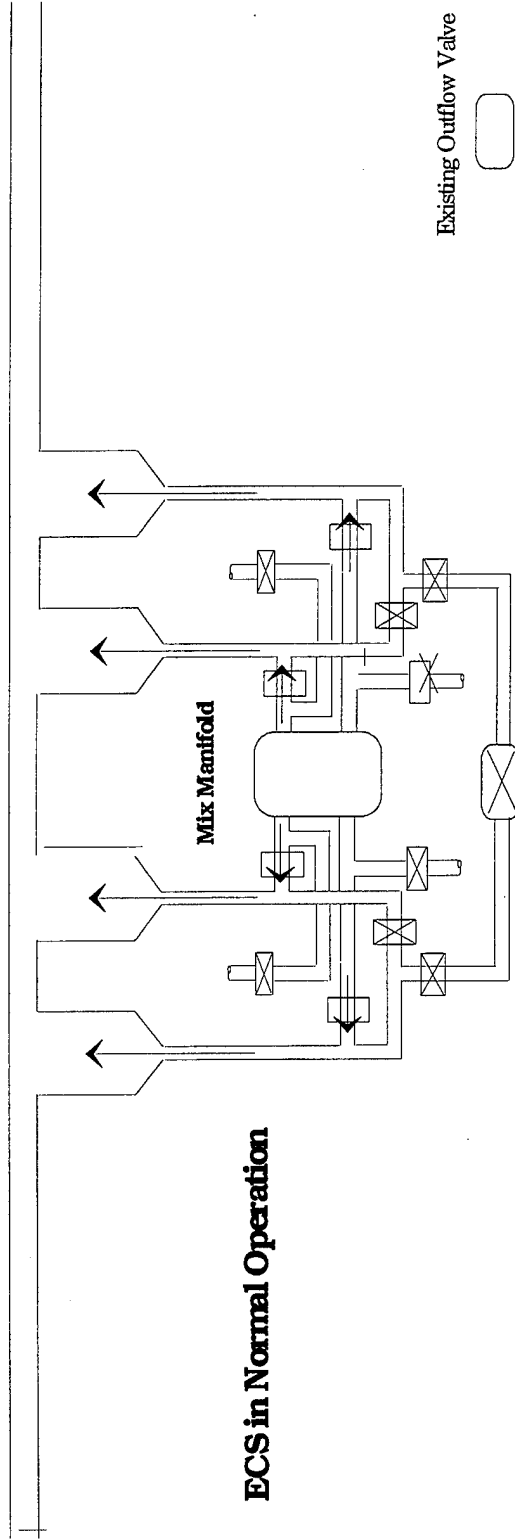

Existing Outflow Valve



ECS in Smoke Control Mode

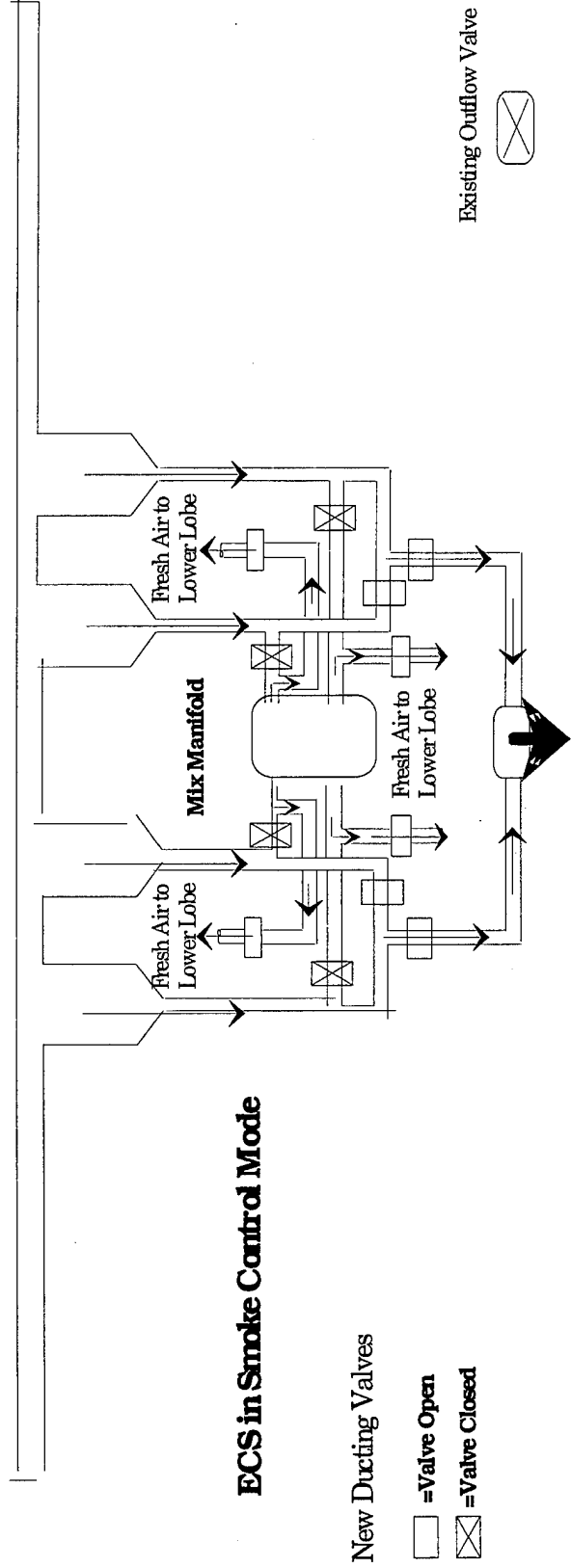

New Ducting Valves

□ = Valve Open

⊗ = Valve Closed

Existing Outflow Valve



New Outflow Valve

FIGURE 20. CONCEPT 2 DUCTING

PERFORMANCE ASSESSMENT OF CONCEPT 2. One of the principal unknowns in Concept 2 is the performance of the flow from the lower lobe up into the cabin. If fresh air in the lower lobe must be ducted fore and aft in order for reversed flow to be effective, the implementation of the concept is more complex. On the other hand if fresh air can merely be diverted into the lower lobe and allowed to seek its own paths up through the return air grilles, the concept becomes much simpler to implement. Without ducting, higher inflow will occur near the center of the airplane; however, since the outflow will occur over the entire length of the cabin, this may not be critical.

The recirculation system would also be shut off when operating Concept 2 in the smoke control mode. Since fresh air from the packs would be flowing through the lower lobe and up into the cabin, operation of the recirculation system might cause short circuiting of some of the fresh air near the recirculation fans back into the mix manifold.

In the smoke control mode, Concept 2 requires the entire air flow within the cabin to stop and reverse direction. Since the ECS was designed to operate in a "forward" fashion, it is unclear as to how the cabin distribution outlets will perform as inlets for the system operating in reverse. Initially this may result in some degree of turbulence and disorganized flow until reverse flow is established.

The influence of the reversed flow into the nozzle and sidewall droppers in Concept 2 will act over the entire length of the cabin. This action, in addition to exhausting smoke, will tend to contain it in the upper levels of the cabin and restrict its spread.

The quantitative performance of the Concept 2 reversed flow scheme for evacuating smoke must be determined by means of testing.

IMPLICATIONS OF CONCEPT 2 MODIFICATIONS. Concept 2 should have little or no effect on the performance of the ECS in the normal mode.

Like Concept 1, Concept 2 would require changes to other systems within the airplane. These include structural modifications to the fuselage at the new outflow valve locations, changes to the pressurization control system similar to those required for Concept 1, electrical modifications to operate the new duct valves, and the same modifications to the ram air system as required by Concept 1. These changes, like those of Concept 1, would involve the nonrecurring costs for design, analysis, tooling, tests, and certification as well as recurring costs for each airplane.

Parasitic drag should not be a problem with Concept 2.

The limited space available in the mix bay may present problems installing the new ducting and valves.

The weight penalty for Concept 2 will be greater than that for Concept 1 because of the larger number of duct valves and the possible requirement for fresh air ducts in the lower lobe. Table 3 gives the estimated weights for Concept 2 modifications.

TABLE 3. ESTIMATED WEIGHTS—CONCEPT 2

Component	Quantity Required	Estimated Total Weight (lbs)
New Outflow Valve	1	20
New Ducting	lot	55
Duct valves	12	72
Ram Air Inlet Valves	2	10
Ram Air Inlet Blowers	2	36
Valve Controls	lot	36
Additional Electrical Wiring	lot	20
Miscellaneous Hardware	lot	20
Total		269

ELEMENTS REQUIRING FURTHER STUDY. The principal issues of Concept 2 which require more detailed analysis are

- The actual behavior of the flow when the distribution system operates in reverse.
- How best to achieve distribution of fresh air into the cabin from the lower lobe.
- The difficulty of installing the required valves and ducting because of space constraints in the lower lobe.
- Designs of the ducting, valves, and controls.
- Changes to the pressurization control system.
- Ram air modifications including design and analysis of the blowers, valves, and ducting to the mix manifold.

RESULTS

ESTIMATES OF TECHNICAL FEASIBILITY.

Both concepts appear to be technically feasible; however, they may not be equally simple to implement or equally cost effective. Both concepts would require modifications to the structural fuselage shell for installation of the smoke vents/new outflow valves and changes to the pressurization control system. Concept 2 requires substantial changes to the distribution air supply ducting and the issue of space constraints must be addressed. Both concepts require additions and modifications to the ram air system. Further study is required to determine whether the presumed benefits afforded during passenger evacuation are worth the additional complexity and weight of the ram air modifications.

COMPARISONS OF CONCEPTS 1 AND 2.

Both Concepts 1 and 2 utilize the existing ECS in the aircraft to provide improved smoke control. As such, they are not stand alone emergency systems which must be carried in the airplane for its lifetime only to be used in the remote possibility of in-flight fire. Rather, they are enhancements to existing equipment which will not degrade its normal performance yet would provide an additional measure of safety to occupants during an emergency.

The principle of exhausting smoke from the upper fuselage lobe was investigated in previous FAA/Boeing tests [3]. Concept 1 of this study expands on this work by adding the improvements of two upper lobe outflow valves (smoke vents) and more importantly, redirecting the flow of fresh air in the cabin. The latter improvement eliminates the experimentally observed turbulent mixing and dispersal effects of the air flow in the region where the smoke is being generated and causes all fresh air entering the cabin to move in the direction of the open upper lobe vent rather than downward to the lower lobe. This will prevent smoke from spreading through the entire cabin.

Although Concept 2 is simple on the surface—merely reversing the direction of conditioned air flow in the cabin—it also poses questions. Can the total airflow be made to stop and reverse direction, how long will this take, and what will be its behavior during this time? Can air be introduced into the cabin without ducting in the lower lobe? Will the distribution system effectively collect and convey the smoke laden air overboard? Unlike Concept 1 in which the general principle has been shown to work, Concept 2 has yet to be demonstrated empirically. If it can be shown by tests that its principles are also valid, its efficiency can be measured against the baseline ECS and Concept 1.

EFFECTIVENESS IN CONTROLLING SMOKE.

Both concepts, assuming the Concept 2 questions raised above can be answered positively, will be more effective in controlling and removing smoke than the ECS without modifications.

When hot smoke rises to the cabin ceiling it is stirred and mixed by the action of the high velocity fresh air from the nozzle and sidewall diffusers and is further spread by the opposing forces of its natural buoyancy and the downward flow of fresh air. This results in churning and general dispersion throughout the cabin. Consequently, the smoke containment problem is exacerbated rather than aided by the normal ECS flow.

Experience from the Air Canada accident [6] showed that when fire develops to the extent that significant portions of the cabin interior become involved, the quantity of smoke and hot gases produced can quickly overcome the ability of the ECS to clear the cabin. Previous studies [2] indicated that the existing ECS, even in high flow mode, is not effective in removing smoke with its normal flow pattern.

As the smoke input and mixing cycle accelerates, the smoke enriched air layer below the ceiling continues to build downwards towards the floor, and the smoke concentration from ceiling to

floor increases rapidly with corresponding deterioration of the cabin atmosphere. T. Eklund of the FAA Technical Center analyzed smoke production and removal in ventilated compartments and theorized that because of stirring effects, the time to remove smoke from a mixed atmosphere in an aircraft cabin may be many times greater than the actual air change rate of the aircraft's ECS [7]. Although the overall cabin air turnover remains high, the general atmosphere of the cabin continues to deteriorate.

The modifications embodied in both Concepts 1 and 2 should greatly improve the ability of the ECS to control and exhaust smoke both by restricting its spread and by exhausting it from the upper part of the cabin where it tends to accumulate naturally. However, the quantitative performance of either concept cannot be assessed until tests are conducted which will directly measure the time for smoke evacuation and the degree to which smoke is constrained from spreading throughout the cabin with the proposed modifications to the ECS.

The following table lists various elements of the two concepts.

TABLE 4. COMPARISONS OF CONCEPTS 1 AND 2

	Concept 1	Concept 2
Principal Features	Diversion of all fresh air into the opposite section of the cabin from the smoke source and the flow of air axially through the cabin towards the upper lobe vent nearest the smoke source.	Reverse direction of fresh air into the cabin so that it flows from floor to ceiling, collection of smoke at the cabin ceiling by the distribution ducting, and venting of smoke through a new outflow valve.
Principal Elements of Modification	Installation of two upper lobe smoke vents, changes to fuselage structure at smoke vent locations, installation of centerline duct valves, modifications to pressurization controls, and additions to the ram air system.	Changes to fresh air supply ducts and risers in lower lobe, installation of ducting valves, installation of a new outflow valve, modifications to the pressurization control system, and additions to the ram air system.
Complexity of Installation	Relatively simple.	Relatively simple as original equipment; more complex as retrofit.
Complexity of Control System Modifications	Minor for ducting valves; higher for automatic pressurization controls	Modest for ducting valves; higher for automatic pressurization controls.
Aircraft Systems Affected	Upper lobe fuselage structure, electrical, interior, ECS controls, distribution ducting, and ram air system.	Lower lobe fuselage structure, electrical, ECS controls, distribution ducting, and ram air system.
Weight	Minor increase—probably less than 200 lbs/airplane.	Greater than Concept 1 owing to the greater number of ducting valves.
ECS Performance in Normal Mode	Will not affect normal ECS operation or performance.	Will not affect normal ECS operation or performance.
Estimated Effectiveness of Smoke Control	Expected to be substantially higher than unmodified ECS and better than Concept 2.	Expected to be higher than an unmodified ECS but may be less than Concept 1 depending on efficiency of reversed flow.

An examination of Concepts 1 and 2 suggests possibilities for smoke control which combine certain features of each. The combination of features may have several iterations, each with its own set of trade-offs. However none could be advanced as being superior until the performance of the basic concepts can be verified by tests.

CONCLUSIONS

1. Modifying the existing B-757 ECS in accordance with Concepts 1 and 2 appears to be technically feasible.
2. Both concepts studied will provide improved cabin smoke control beyond that provided by the existing ECS.
3. Improved smoke control will result from redirecting the fresh air flow and taking advantage of the buoyant nature of hot smoke by exhausting or collecting it near the ceiling.
4. Concept 1 may be more effective and easier to implement than Concept 2.
5. Tests must be conducted in order to verify the effectiveness of smoke control and removal with Concepts 1 and 2.

REFERENCES

1. Lorengo, D.E. and Porter, A., "Aircraft Ventilation Systems Study," Heath Tecna Aerospace Co., FAA Technical Center, Report number DOT/FAA/CT-TN86/41-1, September 1986.
2. Maylor, Elliott L., "Enhanced Emergency Smoke Venting," Boeing Commercial Airplanes, FAA Technical Center, Report number DOT/FAA/CT-88/22, July 1988.
3. Maylor, Elliott L., "Airplane Tests of Enhanced Emergency Smoke Venting," Boeing Commercial Airplanes, FAA Technical Center, Report number DOT/FAA/CT-89/9, March 1989.
4. Eklund, T.I., "Generation of a Buoyant Plume of Artificial Smoke for Airplane Tests," FAA Technical Center, Report number DOT/FAA/CT-90/9, September 1990.
5. McCaffrey, B.J. et al., "A Model Study of the Aircraft Cabin Environment Resulting From In-Flight Fires," Univ. of MD, FAA Technical Center, Report number DOT/FAA/CT-90-22, November 1992.
6. Aircraft Accident Report, Air Canada Flight 797, McDonnell Douglas DC-9-32, C-FTLU, Greater Cincinnati Airport, Covington, Kentucky, June 2, 1983, National Transportation Safety Board, NTSB/AAR-84/09, August 8, 1984.
7. Eklund, T.I., "An Analysis for Relating Visibility to Smoke Production and Ventilation," FAA Technical Center, DOT/FAA/CT-TN84/22, May 1984.

APPENDIX A—PHOTOGRAPHS OF ECS INSTALLATION

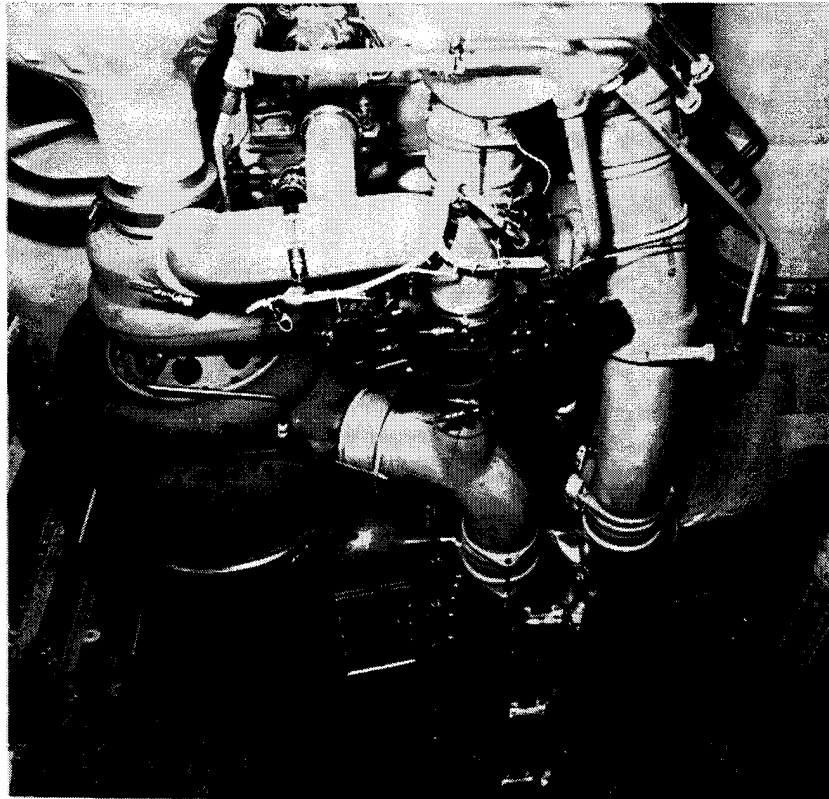

FIGURE A-1. AIR CONDITIONING PACKS

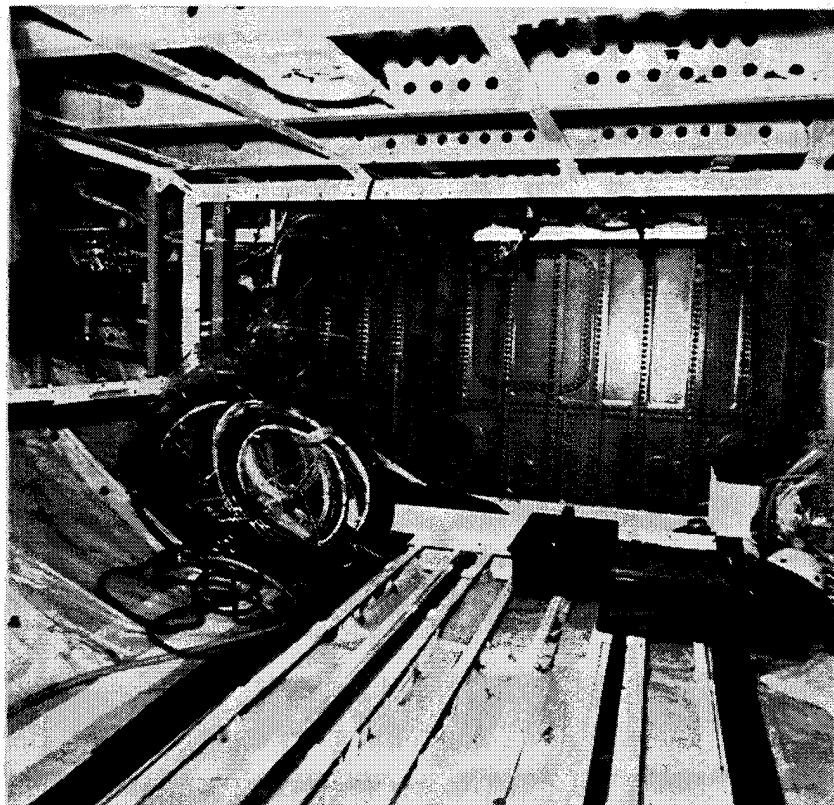

FIGURE A-2. MIX BAY

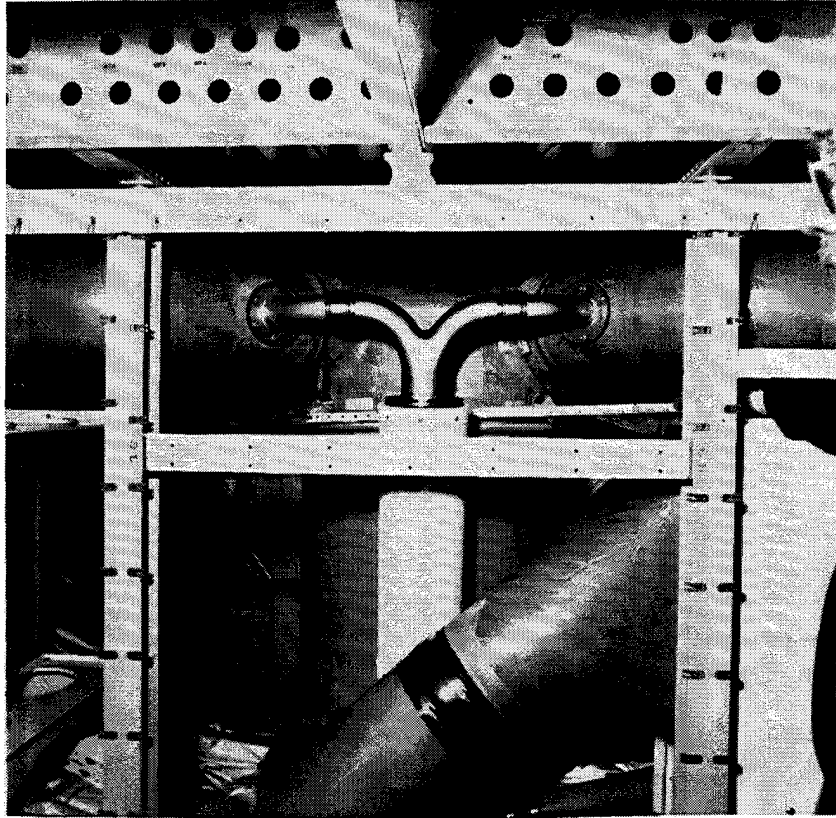

FIGURE A-3. MIX MANIFOLD

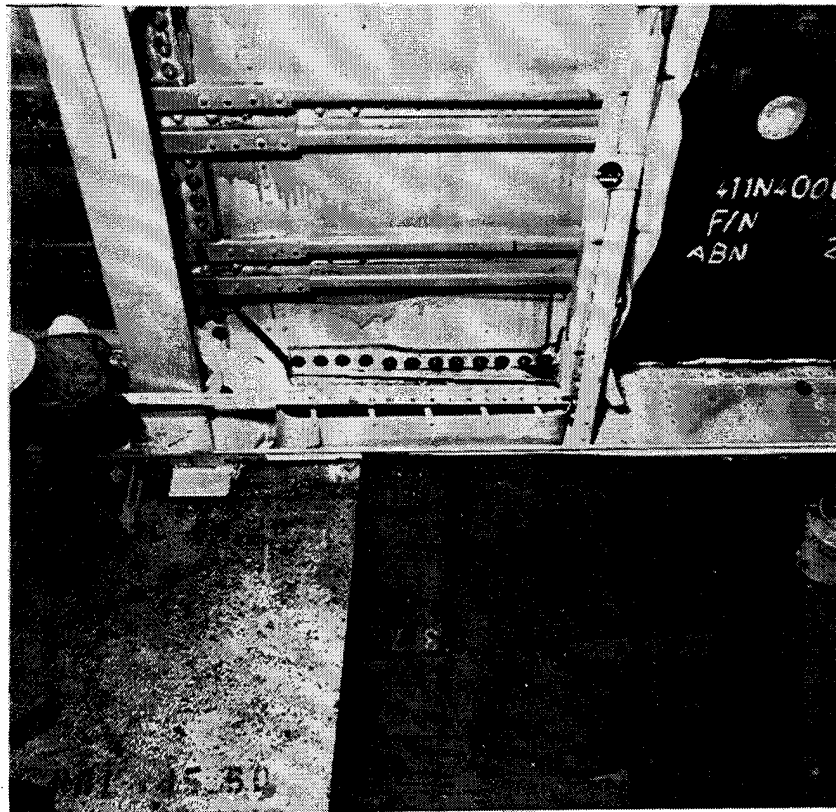

FIGURE A-4. CONDITIONED AIR RISERS AT FLOOR LEVEL

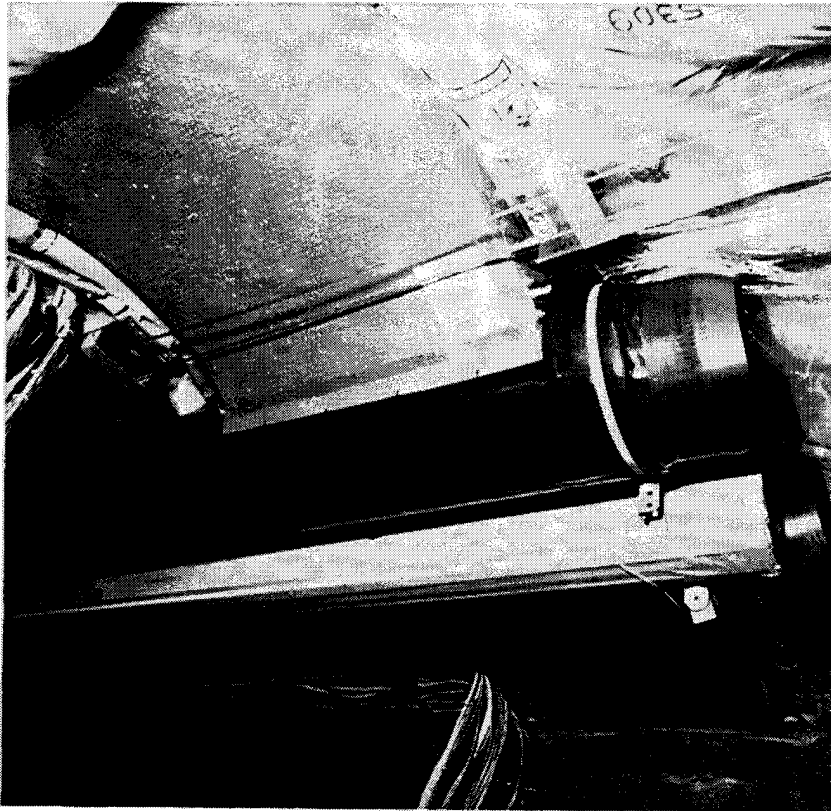

FIGURE A-5. JUNCTION OF RISER AND CENTERLINE DUCT

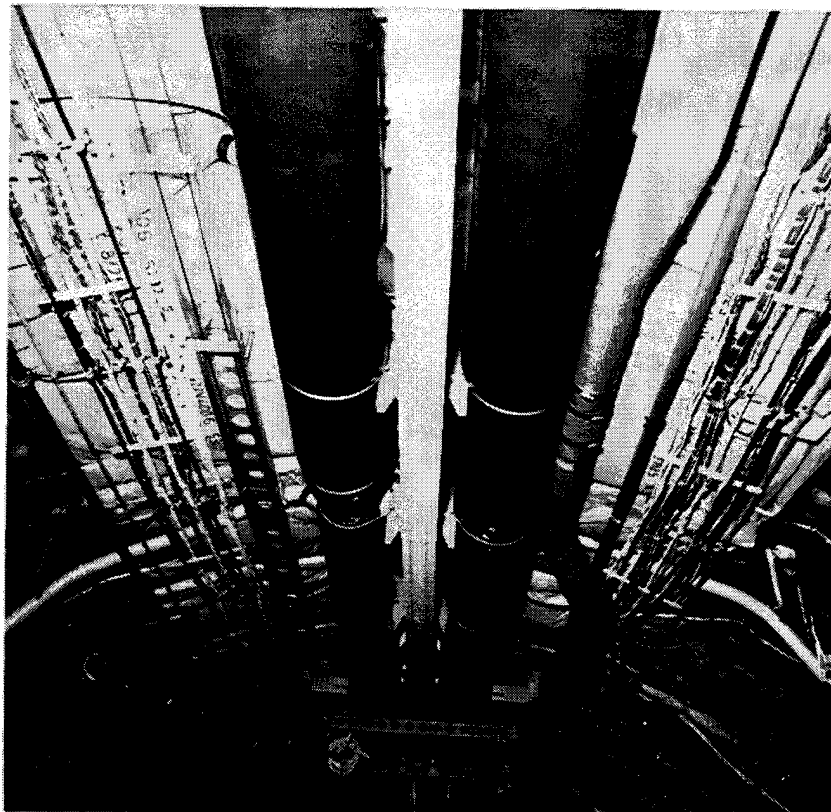

FIGURE A-6. DUAL CENTERLINE DUCTS, PLENIUM AND NOZZLE

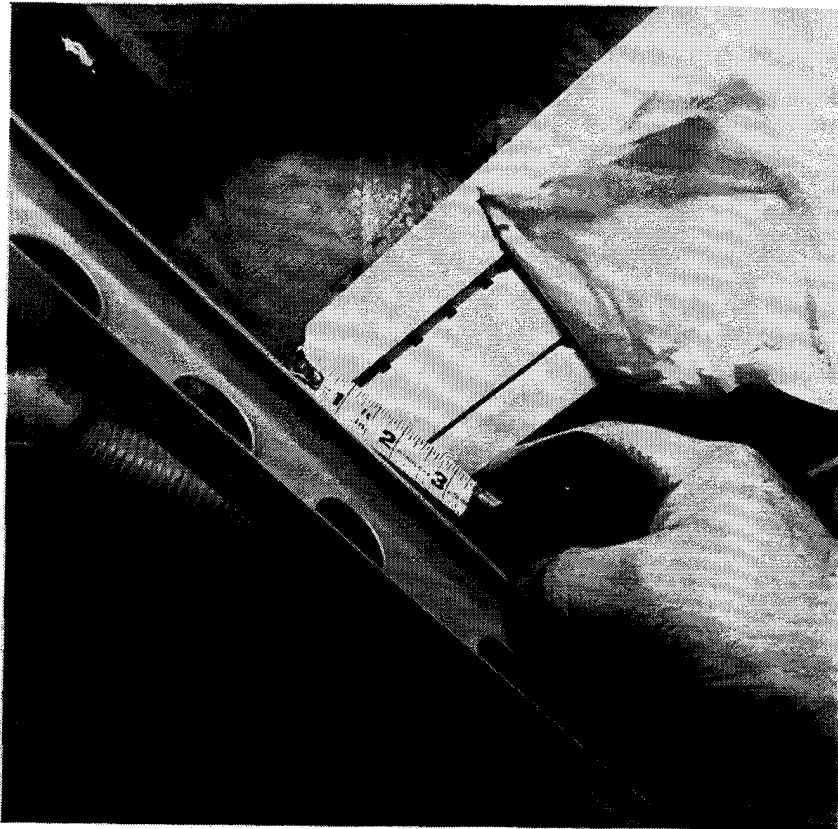

FIGURE A-7. NOZZLE ORIFICES



FIGURE A-8. SIDEWALL DROPPERS FROM CENTERLINE DUCT



FIGURE A-9. INTERIOR ARRANGEMENT

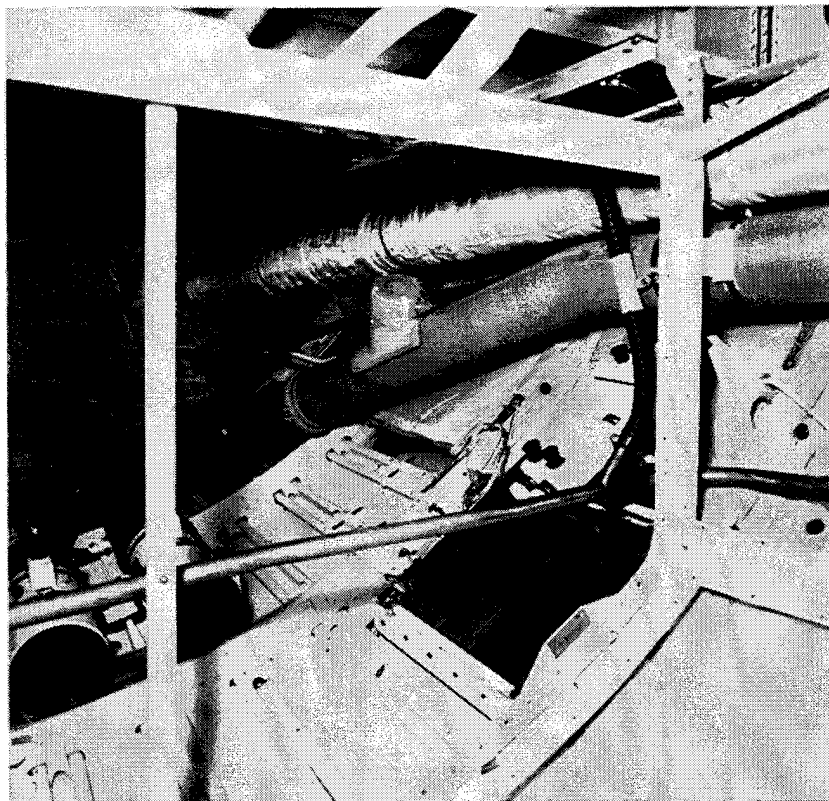

FIGURE A-10. OUTFLOW VALVE FROM INSIDE LOWER LOBE

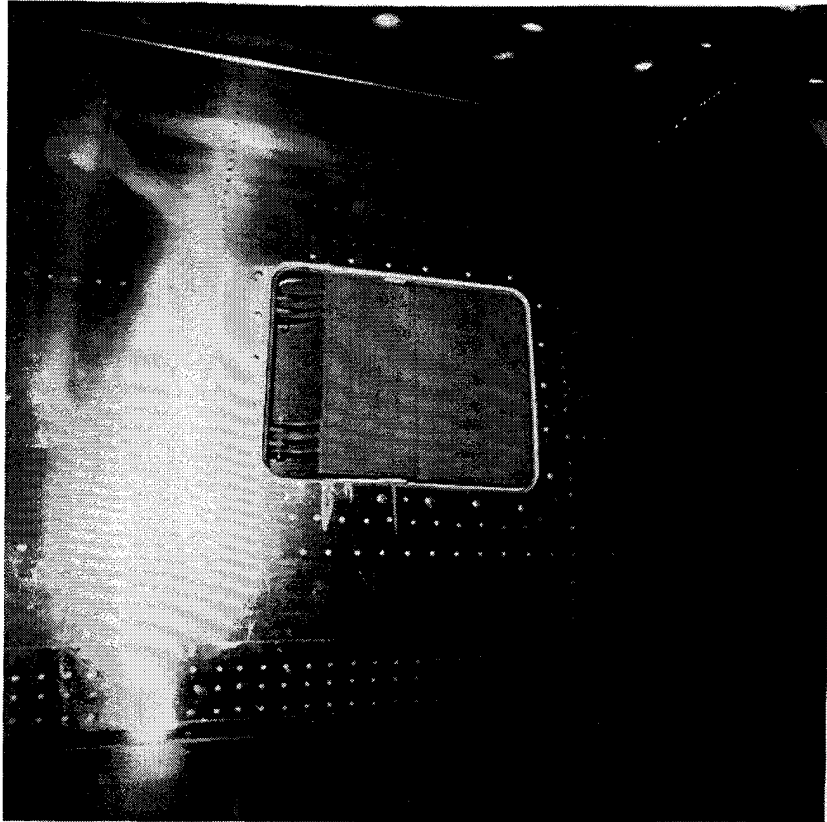

FIGURE A-11. OUTFLOW VALVE FULLY CLOSED

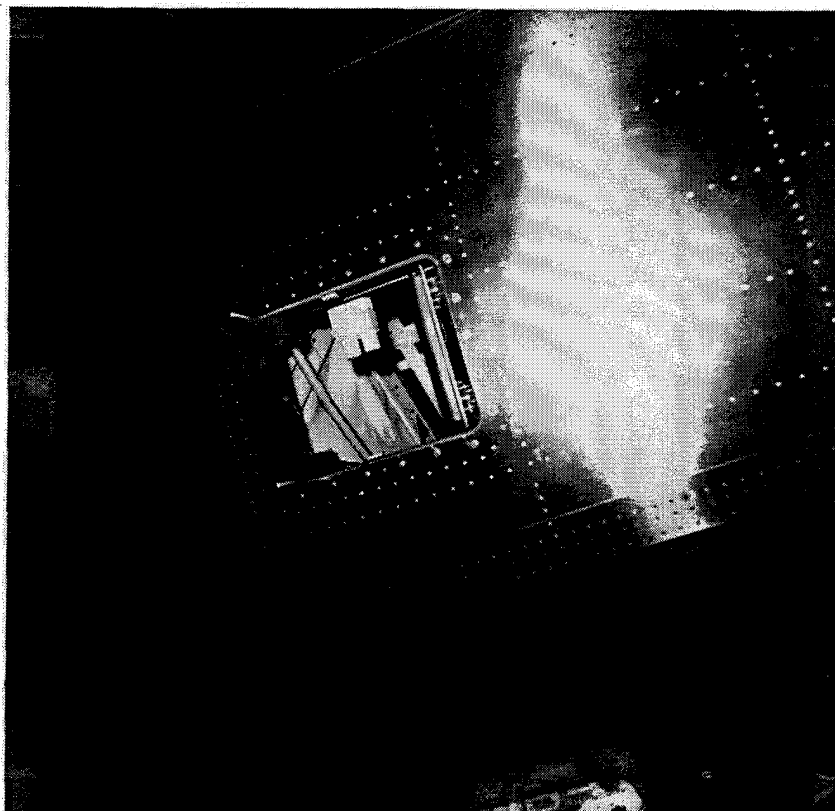

FIGURE A-12. OUTFLOW VALVE FULLY OPEN

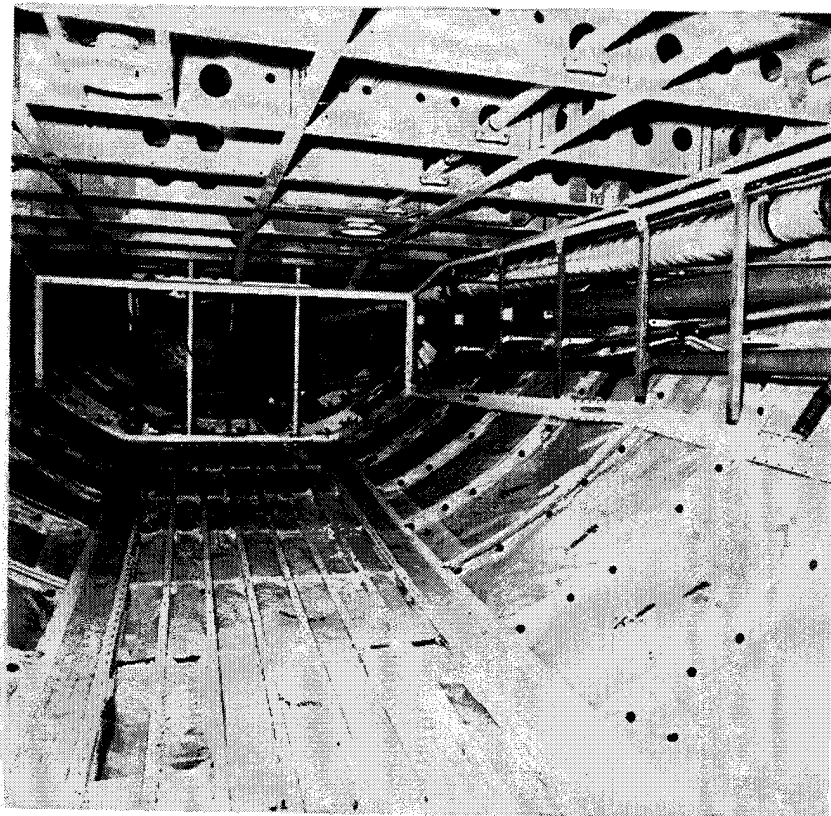

FIGURE A-13. LOWER LOBE AFT CARGO COMPARTMENT

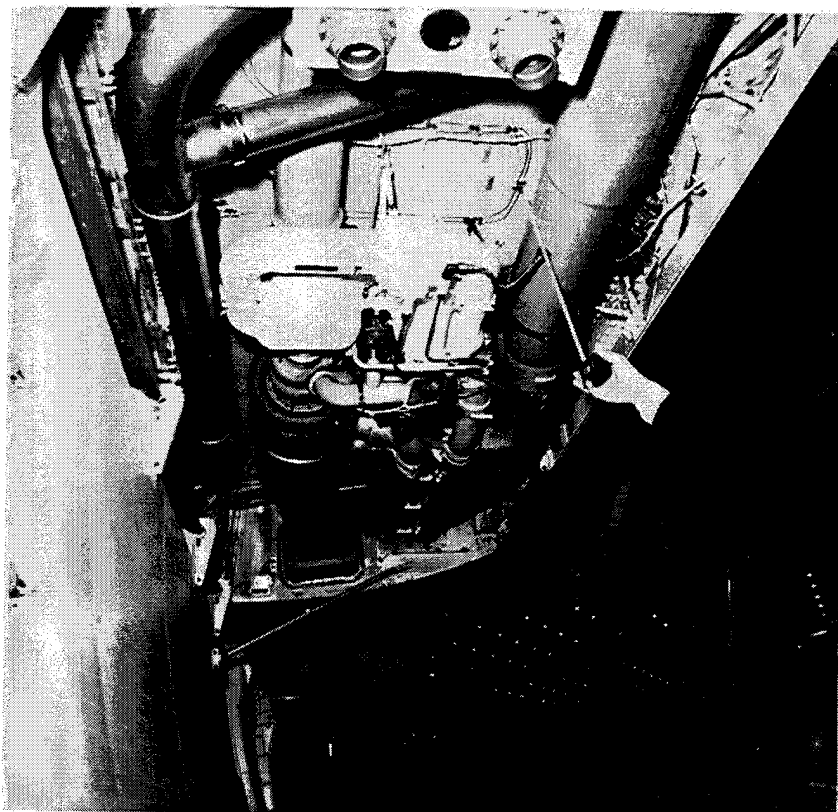

FIGURE A-14. RAM AIR INLET DUCT