

REPORT DOCUMENTATION PAGE

Form Approved
OMB No. 0704-0188

Public reporting burden for this collection of information is estimated to average 1 hour per response, including the time for reviewing instructions, searching existing data sources, gathering and maintaining the data needed, and completing and reviewing the collection of information. Send comments regarding this burden estimate or any other aspect of this collection of information, including suggestions for reducing this burden, to Washington Headquarters Services, Directorate for Information Operations and Reports, 1215 Jefferson Davis Highway, Suite 1204, Arlington, VA 22202-4302, and to the Office of Management and Budget, Paperwork Reduction Project (0704-0188), Washington, DC 20503.

1. AGENCY USE ONLY (Leave blank)	2. REPORT DATE February, 1996	3. REPORT TYPE AND DATES COVERED CONFIDENTIAL FINAL
----------------------------------	----------------------------------	---

4. TITLE AND SUBTITLE DEVELOPMENT OF A NEW TECHNIQUE TO MONITOR PHYSICAL AGING OF AIRCRAFT CANOPY MATERIALS	5. FULL REPORT NUMBER FLR 1620 AFOSR 95-1-0072
---	--

6. AUTHOR(S) E. Ivanova, A. Chudnovsky and C. P. Bosnyak	
---	--

7. PERFORMING ORGANIZATION NAME(S) AND ADDRESS(ES) Department of Civil and Materials Engineering (M/C 246) 2095 Engineering Research Facility 842 West Taylor Street Chicago, Illinois 60607-7023	8. PERFORMING ORGANIZATION REPORT NUMBER #1-02-96
---	---

9. SPONSORING/MONITORING AGENCY NAME(S) AND ADDRESS(ES) The Air Force Office of Scientific Research Directorate of Aerospace and Materials Sciences Bolling Air Force Base Washington, DC 20332-001	10. SPONSORING/MONITORING AGENCY REPORT NUMBER NA 95-1-0072
---	--

11. SUPPLEMENTARY NOTES N/A	19960617 123
------------------------------------	--------------

12a. DISTRIBUTION/AVAILABILITY STATEMENT Approved for public release; Distribution unlimited	12b. DISTRIBUTION STATEMENT N/A
--	------------------------------------

13. ABSTRACT (Maximum 200 words)

A new technique to monitor physical aging of aircraft canopy materials has been developed and proposed in this report. It involves the use of photochrome molecules from the class of spiropyran which, on UV excitation, undergo reversible photochromic conversion to differently colored merocyanine dyes (photoisomerization). The rate of transformation of the merocyanine dye back to the spiropyran in a polymer depends on the segmental mobility and fluctuations of density of the polymer molecules and can be easily followed through their spectral absorbance characteristics. The characteristic relaxation time changes with physical aging of a polymer due largely to densification accompanying the aging process. Thus, employment of photochromes allows quantification of physical aging of polymers.

This technique offers a unique, low-cost and non-destructive way to measure the aging without perturbing the system itself. A potential for the development of a portable device for field measurements should be considered as well.

14. SUBJECT TERMS Molecular label, spiropyran, merocyanine dyes, physical aging, photoisomerization, spectral absorbance, free volume, irradiation	15. NUMBER OF PAGES 30
	16. PRICE CODE

17. SECURITY CLASSIFICATION OF REPORT UNCLASSIFIED	18. SECURITY CLASSIFICATION OF THIS PAGE UNCLASSIFIED	19. SECURITY CLASSIFICATION OF ABSTRACT UNCLASSIFIED	20. LIMITATION OF ABSTRACT ✓
---	--	---	---------------------------------



UIC

Department of Civil and Materials Engineering

**DEVELOPMENT OF A NEW TECHNIQUE
TO MONITOR PHYSICAL AGING OF
AIRCRAFT
CANOPY MATERIALS**

FINAL
~~REPORT~~ REPORT

By

**E. Ivanova, A. Chudnovsky and C. P. Bosnyak
Fracture Research Laboratory
Department of Civil and Materials Engineering
2095 Engineering Research Facilities
842 West Taylor Street
Chicago, Illinois 60607-7023**

Prepared for:

**The Air Force Office of Scientific Research
Directorate of Aerospace and Materials Sciences
Bolling Air Force Base
Washington, DC 20332-001**

February, 1996

TABLE OF CONTENTS

	page
1. Abstract	4
2. Introduction	5
3. Materials and Sample Preparation	12
4. Measurement Procedure	17
5. Results	19
6. Discussion	25
7. Conclusions	28
8. Future Work	28
9. Acknowledgements	28
10. References	29

Approved for Public Release
Distribution Unlimited

AIR FORCE OF
NOTICE OF
This report is approved and is
approved for distribution
can be
INFO :

LIST OF FIGURES

Figure 1. Graph representing typical behavior of a photochromic substance A	7
Figure 2. Reversible photochromic conversion of spiropyran	7
Figure 3. Generalized form of photochromism in spiropyrans	8
Figure 4. Stages of specimen preparation	15
Figure 5. Specimen geometry and structure	16
Figure 6. Experimental setup for measurements of polymer aging with use of photochrome	18
Figure 7. Wavelength scan report for PC+SPK-19	19
Figure 8. Spectral analysis for a system PC+SPK-19	20
Figure 9. Rate of decoloration	21
Figure 10. Effect of necking on color decay for a system PC+SPK-19	23
Figure 11. Decoloration within the process zone for a system PC+SPK-19	23
Figure 12. Output of the amplifier in measurements of polymer aging with use of photochrome	24

1. ABSTRACT

A new technique to monitor physical aging of aircraft canopy materials has been developed and proposed in this report. It involves the use of photochrome molecules from the class of spiropyrans which, on UV excitation, undergo reversible photochromic conversion to differently colored merocyanine dyes (photoisomerization). The rate of transformation of the merocyanine dye back to the spiropyran in a polymer depends on the segmental mobility and fluctuations of density of the polymer molecules and can be followed easily through their spectral absorbance characteristics. The characteristic relaxation time changes with physical aging of a polymer due largely to densification accompanying the aging process. Thus, employment of photochromes allows quantification of physical aging of polymers. It is well-known that physical aging is related to the loss of free volume, which has a certain distribution of sizes at a given temperature and time. It would be very desirable to have some information at the molecular level which can be related to the size distribution of free volume. The technique proposed here can be utilized for this purpose and is based on the analysis of the kinetics of photoisomerization of spiropyrans ultimately mixed with polymers in small concentrations. Such a molecular label, when properly designed for the polymer matrix, can be a sensitive molecular probe of the local environment surrounding the label. As physical aging proceeds, photoisomerization of the label is progressively impeded, reflecting the disappearance of free volume above a certain size, since such isomerization would require free volume of a certain size in the immediate vicinity of the label. The results would provide information of the fraction of free volume above a critical size and its change as a function of temperature and aging time. This technique offers a unique, low-cost and non-destructive way to measure the aging without perturbing the system itself. The spiropyrans are easily incorporated into the polymers via conventional melt fabrication processes. Application of different size probes and molecular modeling can be used to "map" the distribution of spatial fluctuations in canopy-graded materials and to study the perturbation of this distribution with applied stress. A potential for the development of a portable device for field measurements should be considered as well. Evaluation of the effect of physical aging on mechanism and time of crack initiation under particular service conditions would give one a powerful diagnostic tool to prevent the catastrophic failure of canopies. Thus, photochromic techniques coupled with new considerations of intrinsic time and the Lagrangian coordinate system offer a rapid and low cost approach for quantification of the effects of aging of materials. The measurements of intrinsic time changes can then be correlated with other physical phenomena such as material embrittlement. This is viewed as an important step toward meeting the urgent commercial need for prediction of the long term reliability of engineering structures, particularly with newer materials such as plastics.

2. INTRODUCTION

Physical aging is a dominant factor of material degradation in the aircraft canopies made from polycarbonate (PC). This is a natural and inevitable process which could lead to a subtle densification and significant embrittlement of PC. Early diagnostics of PC degradation and aging could become a powerful tool in the prevention of catastrophic failure of canopies. The canopies are expected to be functional after being subjected to severe service conditions such as weathering under various stress levels, rates of loading and temperature variations. Thermal fatigue and contact with aggressive liquids such as deicing and washing fluids, fuels, etc., appear to be important environmental service conditions as well. An early diagnosis of PC degradation and aging and prevention of the catastrophic failure of canopies require fundamental understanding of the time-dependent material response to the above mentioned service conditions. It is generally recognized that transparency grade PC initially has a non-equilibrium glassy state resulting from rapid cooling below the glass transition temperature. When polymers are cooled from the rubbery state to the glassy state, they are in a nonequilibrium state with excess volume and enthalpy. They slowly reach an equilibrium state with concurrent loss of volume (densification) and enthalpy. This phenomena, which is usually studied as a function of isothermal (sub- T_g) annealing time, is referred to as physical aging. As well as densification, mechanical properties of polymers change as a consequence of physical aging; namely, the materials becomes brittle. Associated with enthalpy and volume recovery are changes in the physical and material properties of the polymer due to

physical aging: an increase in density, tensile and flexural yield stress, and elastic modulus; a decrease in impact strength, fracture energy, ultimate elongation, and creep rate, and a transition from ductile behavior to brittle fracture. On a molecular level, volume recovery in polymer glasses, or physical aging, has been hypothesized to occur by the disappearance and reduction in the magnitude of local free volume. It would be very desirable to have some information at the molecular level about the distribution of free volume and its change with aging. Evaluation of the influence of physical aging on crack initiation and growth, together with the means to monitor the aging process would give one a powerful diagnostic tool.

Photochromes offer a unique, low-cost and non-destructive way to measure aging without perturbing the system itself. Photochromism is associated with a reversible light-induced processes that results in a color change. It can be defined as a reversible change of a single chemical species between two states having distinguishably different absorption spectra; such change being induced in at least one direction by the action of electromagnetic radiation [1]. The reversible transition from transparent (state A) into colored (state B) can be schematically represented by the following equation:

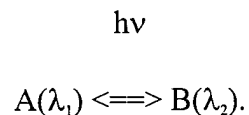

Figure 1 shows the typical response of a photochromic compound A to an activating radiation. Initially the system contains only the A state of the molecule. At time t_1 , the exciting radiation is turned on, producing the colored form, which increases the ratio of B to A molecules. The concentration of B builds to a limiting value with time until the

Heterolytic cleavage is one of the most common processes of photochromism. It is based on the fact that the excitation energy of a photoactivated molecule may cleave a single bond, leaving charged moieties that exist as isolated ions or may still be connected by other chemical bonds as shown above. They may recombine to regenerate the original molecule. Photochromism in spiropyrans occurs in a heterolytic manner [3].

The term spiropyran is used to denote very generally a molecule containing a 2H pyran ring in which the number-2 carbon atom of the ring is involved in a spiro linkage. The molecule contains structural features such that after a heterolytic cleavage of the 1,2-single bond of the pyran ring the charges of the resulting zwitterion are stabilized by resonance, in the usual sense that various valence-bond structures can be written. A more generalized reaction which is now generally believed to be responsible for photochromism in these compounds can be written as follows:

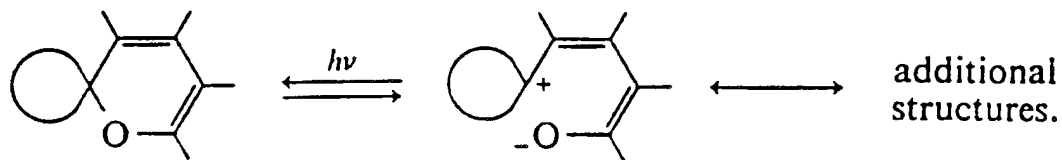

Figure 3. Generalized form of photochromism in spiropyrans

The spontaneous thermal reversion of the irradiated to the stable state may take place over time spans ranging from microseconds to minutes. The reversion rate is readily controllable [4].

The important factors controlling the rate are the structure of the photochromic material, the temperature, the viscosity and the polarity of the matrix. As expected, increasing the temperature will increase the fading rate and increasing matrix viscosity will decrease the rate [5].

Photochromic behavior is kinetic. Considering the A-to-B conversion, one finds that only certain wavelengths of radiation will excite A. According to Einstein's photoequivalence law, each quantum absorbed by the photochrome creates an excited molecule. The Grotthus-Draper law says that only the radiation that is absorbed can produce a chemical change. The number of photons absorbed is controlled by such factors as concentration and extinction coefficient of the photochrome or the wavelength of the exciting radiation, length of the cell, and screening and absorption coefficients of other components (e.g., solvents) in the system. The exciting radiation must be of sufficient energy to activate the photochromic species so that it will pass over the most favorable minimum energy barrier during conversion of A state to B state [6].

The important characteristics of a photochromic system include the absorption spectra and the extinction coefficients of the parent compound and the photoproduct, the quantum yield of the forward reaction, the occurrence of photochemical reaction and the effect of the environment factors such as matrix type and temperature. The concentration of the colored form at the steady state is largely dependent on the intensity of the exciting radiation, the temperature, the kinetics of the reverse reaction, and the influence of the solvent on the reverse and forward reactions [7].

The rate of transformation of the merocyanine dye back to the spiropyran in a polymer depends on the segmental mobility, chain polarity and fluctuations of density of

the polymer molecules and can be followed easily through their spectral absorbance characteristics.

The spiropyrans are easily incorporated into the polymers via conventional melt fabrication processes. The rate of decoloration that takes place after the color is induced by UV irradiation can be used for measurements of characteristic relaxation time. It changes with physical aging of a polymer due largely to densification accompanying the aging process. Photochromism of molecular probes is a technique which is sensitive to the physical aging and the distribution of local free volume in polymer glasses. The dominant factor in the photochemistry of photochromes is the local free volume in the vicinity of them because their signals are strongly dependent on their rotational mobility in the matrix. This sensitivity of the photochromes to the local free volume can be utilized to probe the amorphous structure. Since physical aging reduces free volume, it is reasonable to expect that the behavior of a photochemical label will be affected by it.

Photochromes as labels can be selectively attached to the side chain, main chain or chain ends of the polymer [8]. Such selective-side labeling would hopefully allow one to identify motions associated with the specific location of the polymer chain. The main principle of this proposed technique is to follow the photoisomerization of spiropyrans by UV spectroscopy and extract kinetic parameters for evaluating it as a function of temperature and physical aging time. It will also be interesting to label the polymer chain at specific sites and to follow physical aging by photoisomerization as a function of the location of the label in the chain.

Photochromic techniques coupled with new considerations of intrinsic time and the Lagrangian coordinate system offer a rapid and low cost approach for quantifying the

effects of aging of materials. The measurements of intrinsic time changes can then be correlated with other physical phenomena such as material embrittlement. This is viewed as an important step toward meeting the urgent commercial need for prediction of the long term reliability of engineering structures, particularly with newer materials such as plastics.

3. MATERIAL AND SAMPLE PREPARATION

A poly (bisphenol A carbonate) as made by the Dow Chemical Company was used throughout this study. The material was free of additives and had the following molecular weight characteristics determined in methylene chloride at 25°C by GPC: Mw=36,120; 3MFR. The polycarbonate (PC) flakes were dried at 120°C for several hours in vacuo prior to compression molding. Based on the commercial availability, spectral absorbance characteristics, molecular size and suitability for measurements, four different photochromes were chosen for investigation. Those are from the class of spiropyrans which undergo ultra-violet excitation to the metastable (colored) merocyanine conformation and then relax back to the colorless state. Spiropyran products were synthesized by Nippon Kankoh-Shikiso Kenskyusho Co., Ltd. (Japanese Research Institute for Photosensitizing Dyes Co., Ltd.). Description of photochrome products used in research are given in Table I.

PRODUCTS	COLOR CONVERSION	M.P.	TYPE
SPK-12	transparent-magenta	236	Deep Color
SPK-14	transparent-blue	256	Deep Color
SPK-19	transparent-red	222	Deep Color

Table I. Photochromic products used in research

Characteristic data of the finally selected spiropyran is given below in Table II.

TRADE NAME	SP-3
CHEMICAL NAME	1',3'-Dihydro-5'-chloro-1',3',3'-trimethyl-6-nitro-spiro [2H-1-benzopyran-2,2'-[2H]indoline]
CHEMICAL FAMILY	Spiropyran
FORMULA	C ₁₉ H ₁₇ N ₂ O ₃ Cl
MELTING POINT	150°C
APPEARENCE AND ODOR	Yellowish white powder, odorless
PURITY BY HPZC	99.7%
λ max	255 nm (1/100,000 acetonitrile)
OPTICAL DENSITY	0.692 (1/100,000 acetonitrile)

Table II. Characteristic data for SP-3

A general procedure was adopted for compression molding the polycarbonate. The polycarbonate flakes were first dried in vacuo at 120°C for a minimum of four hours. The dried flakes were placed in the mold heated to 250°C, held three minutes under low pressure, the platen pressure was then increased to 800psi and held for an additional three minutes and then cooled under pressure to ambient temperatures within 8 minutes.

The spiropyrans were easily incorporated into polycarbonate via conventional melt fabrication processes. Different probes of spiropyrans were introduced into the polymeric matrix and tested. Based on the spectral absorbance characteristics and sensitivity to UV irradiation, the most appropriate concentration of spiropyran in a PC

matrix was selected. PC with 1% weight fraction of SPK-12, SPK-14, SPK-19 was used in research. 0.1 % weight fraction was used for SP-3.

The spiropyrans were incorporated into the polymer matrix using different procedures: Method (a): 60 g of polycarbonate was intimately mixed with 0.6 g of spiropyran (SPK-12, SPK-14, SPK-19) and 100 ml of methanol (CH_3OH) using a Waring blender (Waring Products Division, Model 33BL79). After evaporation of methanol and drying in vacuo at 120°C for four hours a film, 0.155 mm thick, was obtained by compression molding under similar conditions as described for PC.

Method (b): Films with thickness 0.3 mm obtained as in method (a) were then used to make "sandwich" type specimens: two sheets of polycarbonate, obtained by compression molding, 2 mm thick, were placed on either side of the polycarbonate thin film containing spiropyran and recompression molded. When this "sandwich" was irradiated with UV light from both sides, the inner layer was observed to undergo intense coloration. For calibration purposes and to study the deformation at the inner layer, similar "sandwich" type specimens with an inner layer of pure PC with an ink-printed mesh on its surface were designed.

Method (c): 100g of PC was mixed with 0.05 g of SP-3 in 40 ml of methanol (CH_3OH). Then the procedure was similar to the one described in method (a).

The generalized scheme of specimen preparation can be described as follows: blending by the Waring blender of PC flakes to make a powder, then mixing PC powder with the solution of spiropyran in methanol, vacuum heating of the mixture and pressing of the specimen material under the above noted conditions. Characteristic stages and the appearance of the material are shown in Figure 4.

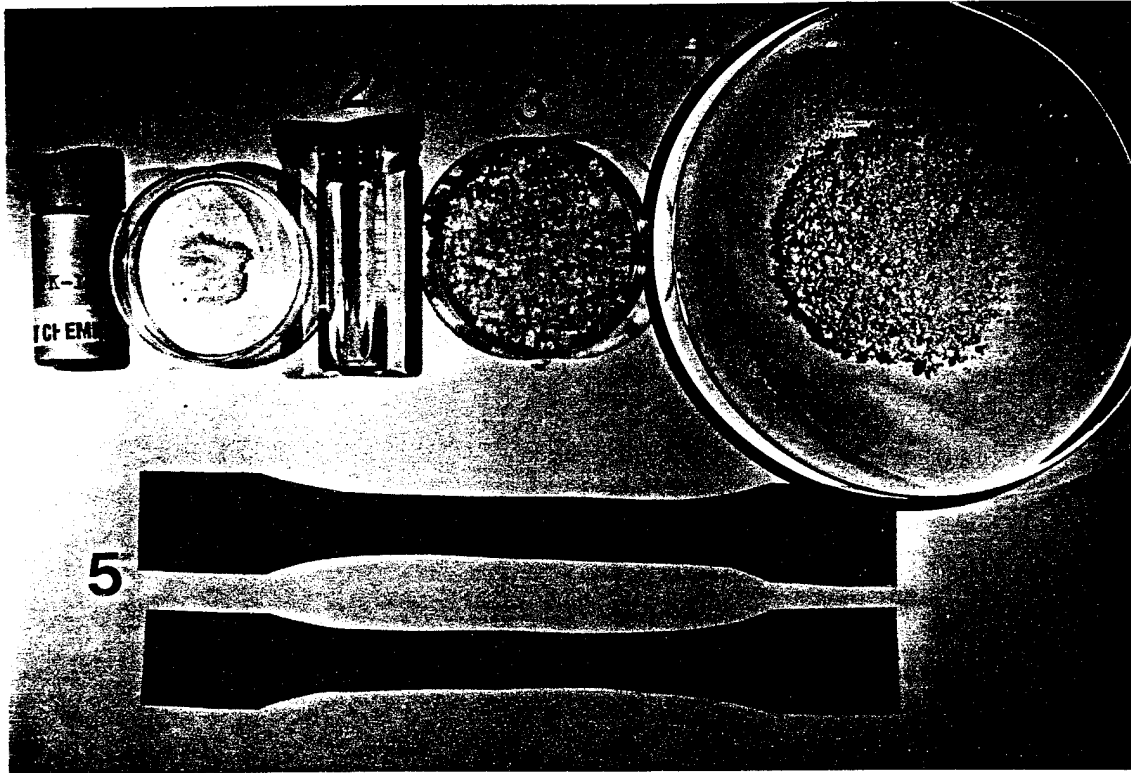

Figure 4. Stages of specimen preparation: 1) Original Powder SPK-12; 2) SPK-12 dissolved in methanol CH_3OH ; 3) Wet powder PC+SPK-12 after Waring blender; 4) Dry powder PC+SPK-12 after heating (120°C) in vacuum oven for 4 hours; 5) Samples of PC+SPK-12

The resultant “sandwich” and “bulk” prepared samples were shaped into specimens with dimensions shown in Figure 5.

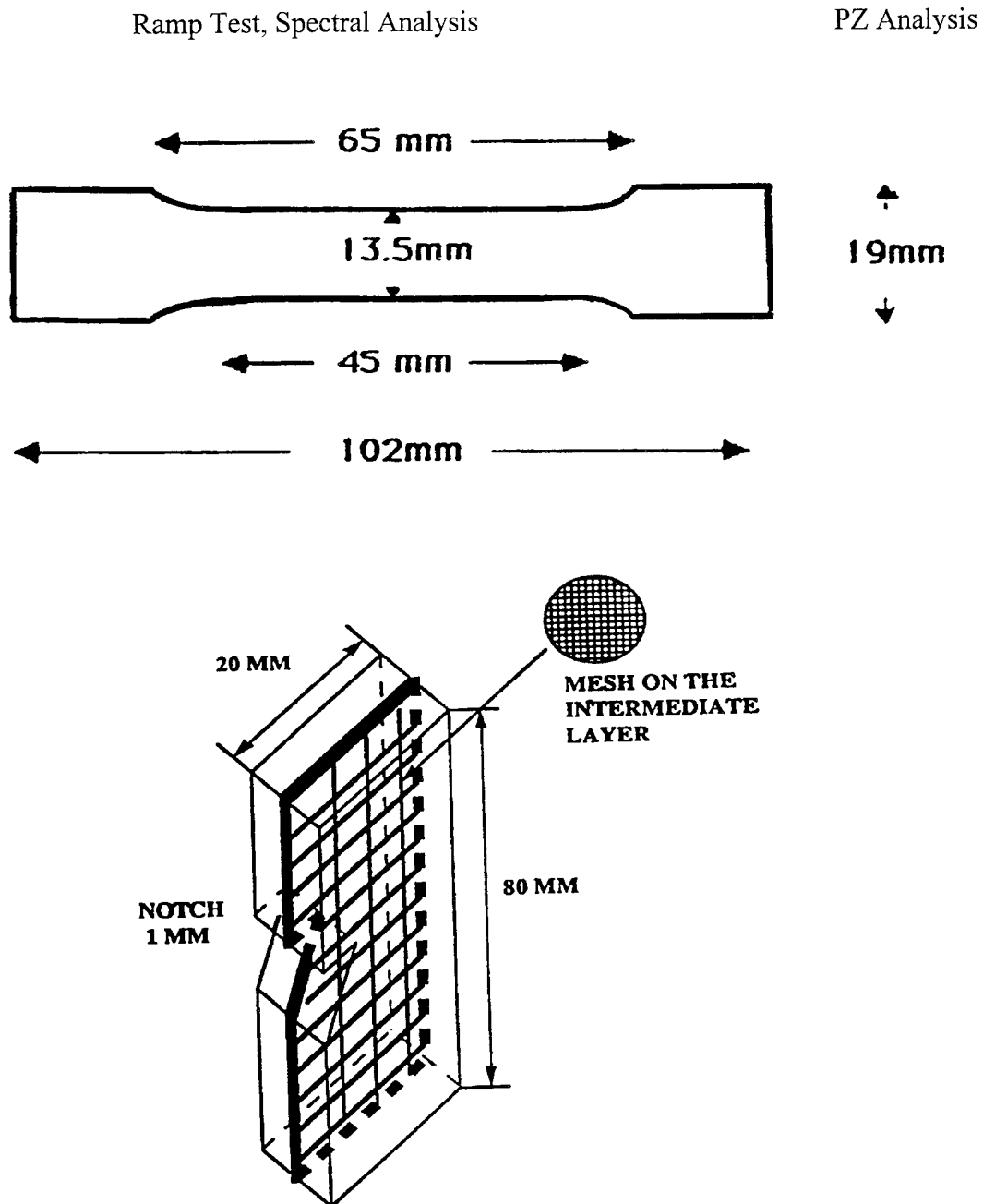

Figure 5. Specimen geometry and structure

4. MEASUREMENT PROCEDURE

Spectral absorbance characteristics of the spiropyran induced into the polymeric matrix were measured using Hewlett Packard Diode Array Spectrophotometer (Model 8452A) attached to a computer analyzing system (Zenith/Data Systems).

The simple experimental setup consists of a low wattage (20mW) laser (Model U-1335 He-Ne laser, Uniphase Corp.), photosensor and data processor (Model 1815 Optical Power Meter, Model 818-SL Detector, Newport Corp.), UV lamp (Model UVL-56, UVP Inc.), and specimen pulling device as shown schematically in Figure 6.

A low wattage laser is employed for measurement of the specific absorption wavelength of the merocyanine dye without reexcitation of the sample, thus allowing, if desired, mapping of structural heterogeneity within the material. The thin film of polycarbonate containing spiropyran (SP-3) was irradiated using a UV lamp for sufficient time to colorize, and immediately placed in the sample holder at room temperature. Afterward, the rate of decoloration was measured for different UV exposure times. The light intensity was measured with a photosensor connected to an optical power meter. Reproducibility tests were performed to check the results. It appears that the results of measurements are reproducible.

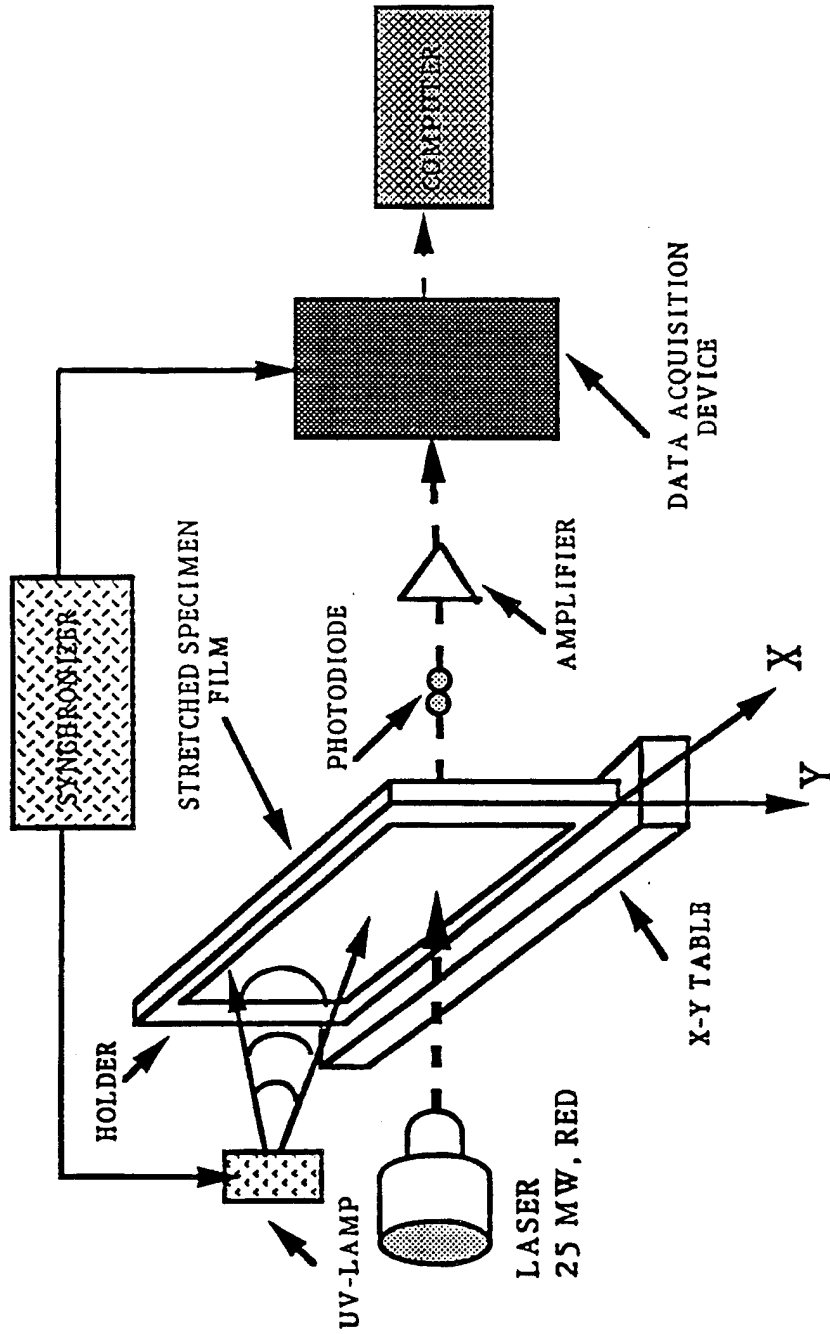

Figure 6. Experimental setup for measurements of polymer aging with use of photochrome

5. RESULTS

Wavelength scan reports were recorded for different UV exposure times. Absorption spectra of the spiropyran in PC and its merocyanine form after different UV exposure time by UVP Corp. lamp are shown in Figure 7.

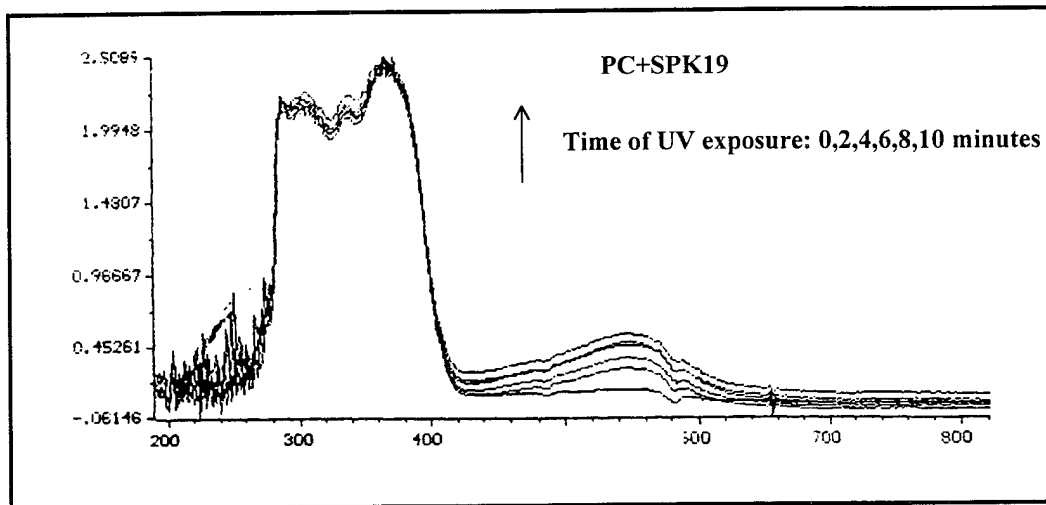
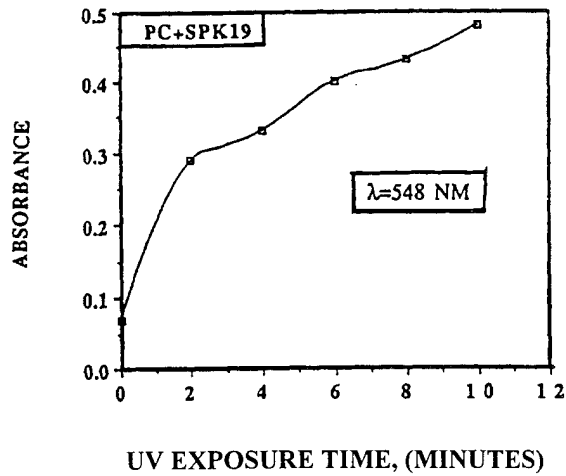

Figure 7. Wavelength scan report for PC+SPK-19

The absorption peaks were observed at 316 nm for spiropyran form and at 548 nm as well as 370 nm for merocyanine form in PC. The effect of UV exposure time on the absorbance characteristics of different spiropyrans was established based on the analysis of the wavelength scan reports. Absorbance has a tendency to increase with increase of UV exposure time and then decrease with time when photoisomerization of spiropyrans is in process, as shown in Figure 8.

a)



b)

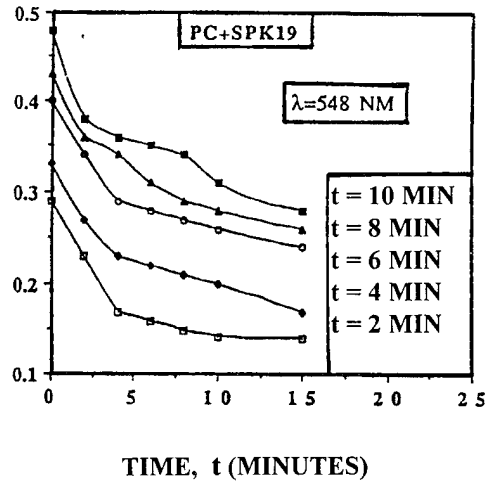

Figure 8. Spectral analysis for a system PC+SPK-19:
 a) Absorbance vs UV exposure time
 b) Absorbance vs time for different UV exposure time

The rate of the color decay was obtained for each spiropyran at characteristic wavelength peak. Typical curves for a color decay rate and kinetic coefficients of this process are given in Figure 9. Abbreviation MR in Figure 9 (a) stands for meter readings recorded during tests.

a) Rate of Decoloration for PC+SP-3 b) Calculating Kinetic Coefficients for PC+SP-3

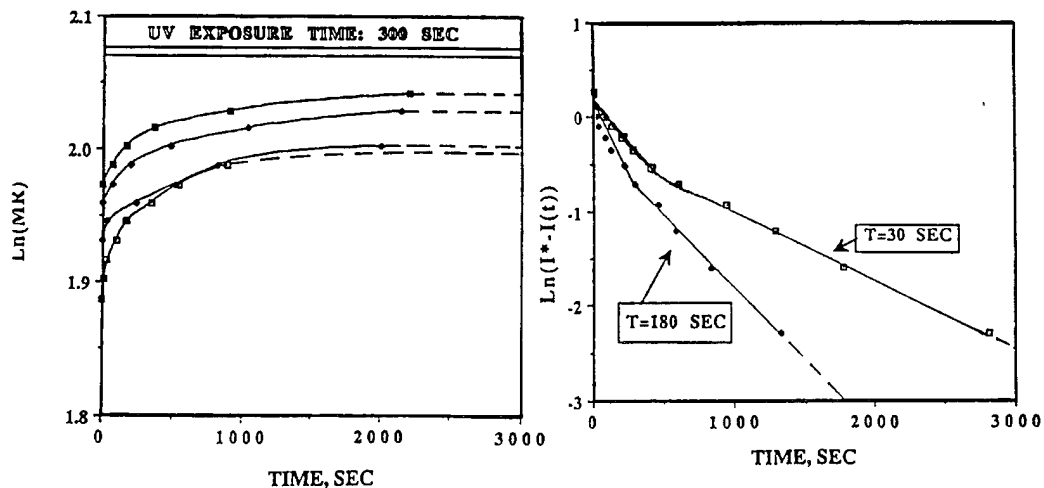

Figure 9. Rate of decoloration (a) and kinetic coefficients (b) of this process for PC+SP-3

Based on the spectral analysis two spiropyrans (SPK-19 and SP-3) were selected for further investigation due to their absorbance characteristics and relatively fast color decay. The appropriate concentration of the spiropyrans in polymer matrix was also chosen based on this analysis.

A non-irradiated specimen is colorless and transparent while an irradiated one has a deep color due to UV exposure. The effect of necking on the coloration rate was also observed (Figure 10). Evident decoloration occurred in the necked area. Changes in free volume, temperature and density fluctuations are associated with necking. Therefore, necking will speed up color decay and change the kinetics of photoisomerization. This work may provide new insights into the energetics of polymer failure. The necking phenomena which is important for toughness evaluation can be applied for this analysis.

It shows how spiropyrans are strongly influenced by matrix local structural changes. The energy barrier for decoloration in undeformed PC is evaluated by an Arrhenius calibration curve and reflects the energy measure of polycarbonate conformational obstacles. These obstacles are reduced, or completely removed during the rapid transformation of material undergoing necking, resulting in a reduction in the overall energy barrier for the transformation. The formalism is analogous to that proposed by Eyring for stress-activated flow in a viscous medium.

Tensile testing of the dumbbell shaped specimens was performed at 23°C and 50% relative humidity using an Instron testing machine at initial displacement rates in the range 0.05-0.1 mm/sec. Decoloration within the process zone of the single edge notch (SEN) specimen was observed and analyzed (Figure 11). Spatial heterogeneity of stress distribution leads to a non-homogeneous decoloration within the material. To “map” the distribution of spatial fluctuations and the perturbation of that distribution with stress, “sandwich” type specimens were created and tested.

A typical output of the amplifier in measurements of polymer aging with use of photochrome is shown in Figure 12.

It should be noted that the sample films showed no irreversible coloration throughout the present work with more than 100 cycles of UV irradiation and decoloration.

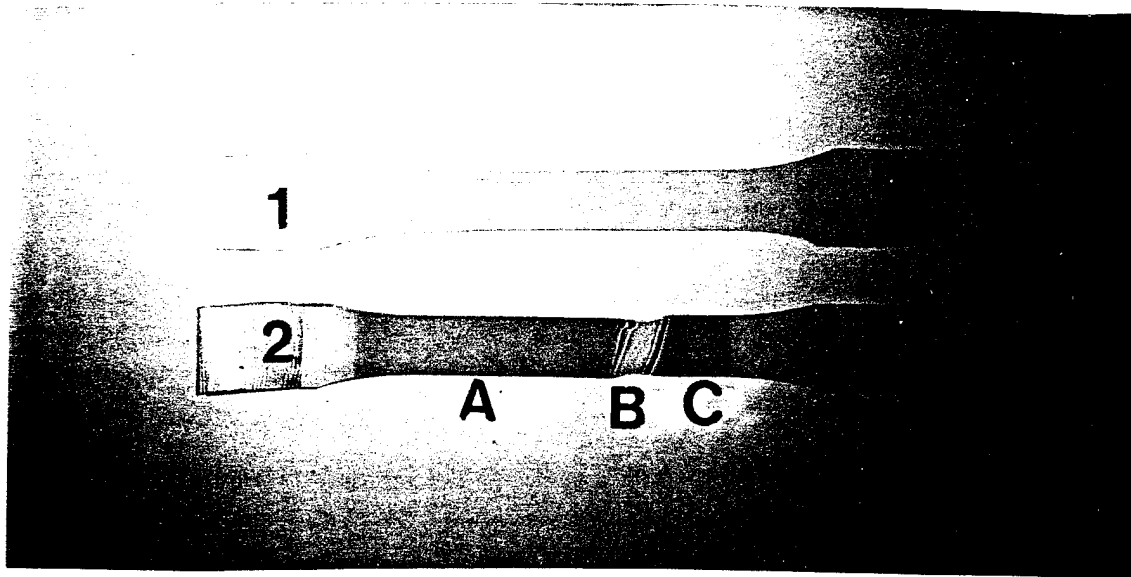

Figure 10. Effect of necking on color decay for a system PC+SPK-19

- 1. Original specimen
- 2. Irradiated and necked specimen
- A,C - Irradiated areas, B - Necked area

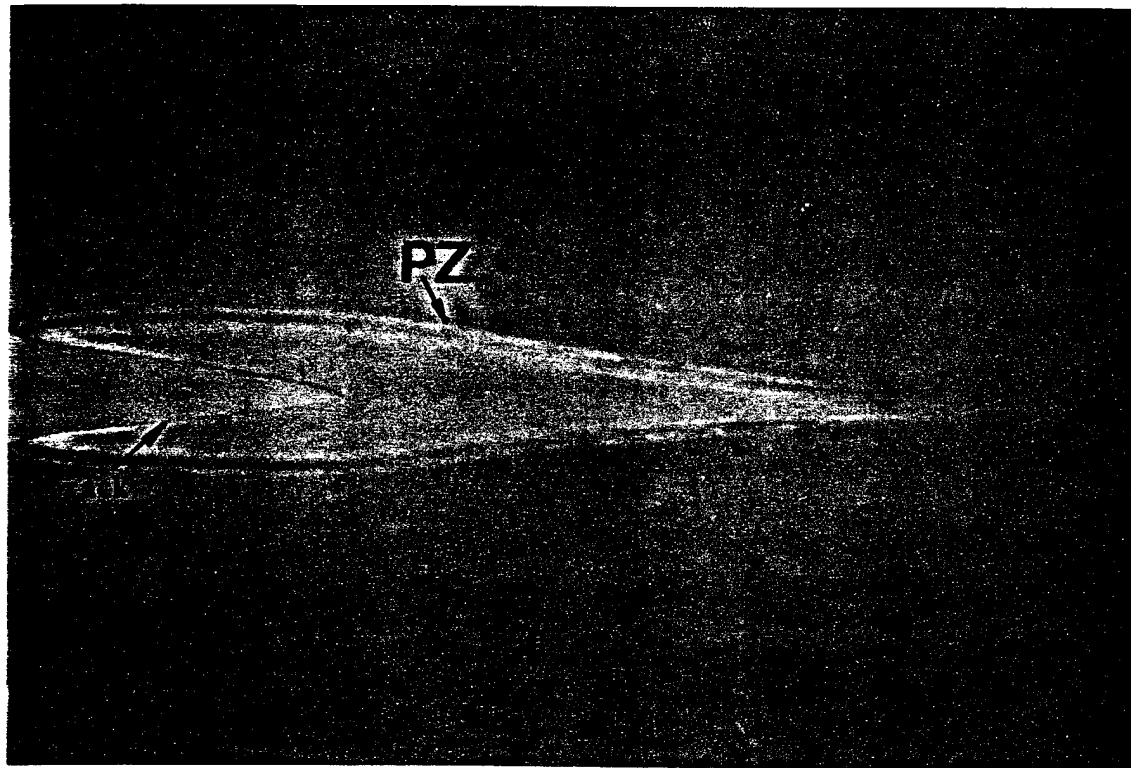

Figure 11 Decoloration within the process zone for a system PC+SPK-19.

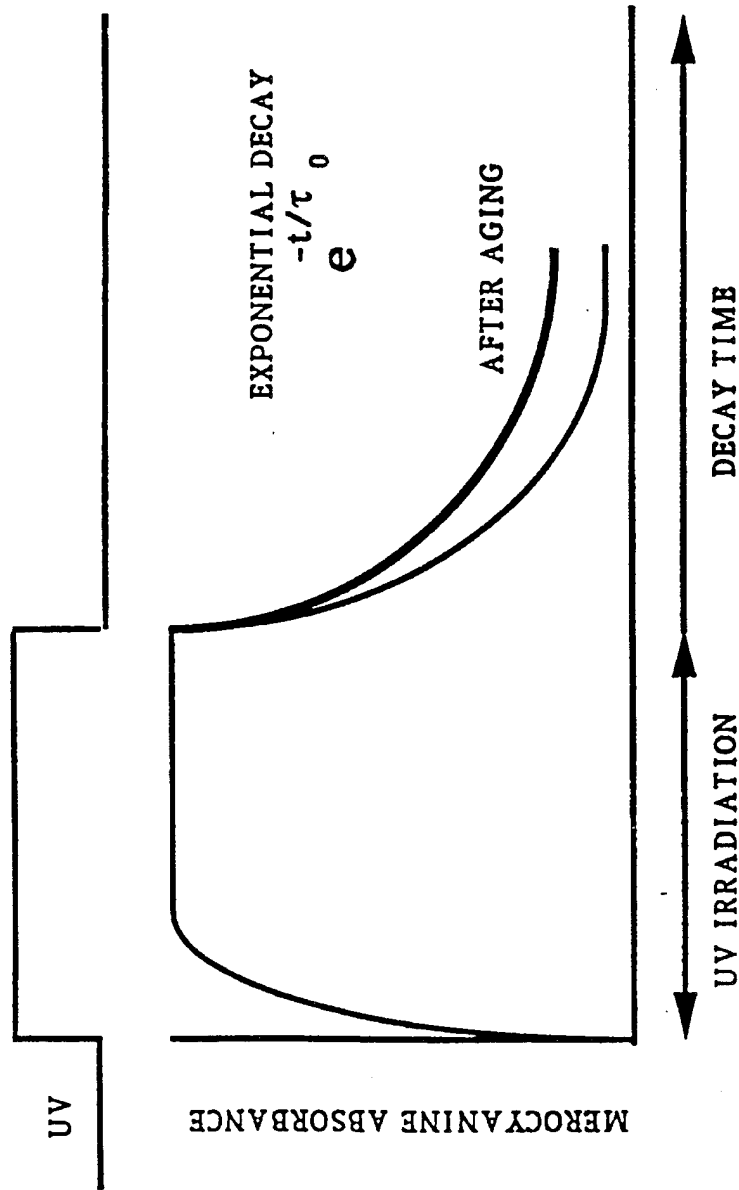

Figure 12. Output of the amplifier in measurements of polymer aging with use of photochrome

6. DISCUSSION

The kinetics of reversible photoisomerization can be analyzed using the following equations:

$$I(\delta) = \left(1 + \frac{D_\infty}{2} + \frac{D_\infty^2}{12}\right) \ln|\delta| - \left(\frac{1}{2} + \frac{D_\infty}{6}\right) \delta + \frac{\delta^2}{24}$$

$$I(\delta) = At + \text{constant}$$

where $A = -I_0 \phi_i \epsilon_i / y_\infty D_\infty$, D are optical densities at the photostationary state and at time t , respectively, $\delta \equiv D_\infty - D$, I_0 is the radiation intensity, ϕ_i is the quantum efficiency, ϵ_i is the molar extinction coefficient, and y_∞ is the fraction at the photostationary state. In solid films there is a certain extent of a relatively fast reaction followed by a much slower reaction that can be seen in Figure 9 (b). The decoloration of merocyanine form proceeds exponentially for temperatures above T_g (150°C) of the matrix PC. But, for $T < T_g$ the decoloration curves deviate from the single exponential type and can be divided into slow decoloration and fast decoloration [9]. The early stage of the decoloration curves correspond to the fast decoloration followed by slow decoloration. The rate constant k_1 , for slow decoloration was calculated from the slope of the linear part in the later stage of decoloration. A similar procedure could be applied for k_2 . The existence of slow and fast decoloration has been attributed to the formation of two types of isomers of the merocyanine form, and can be related to the homogeneous distribution of free volume in the matrix polymer [10].

A kinetic profile of this type can be best analyzed by a biphasic process as follows:

$$e^{-I'(\delta)} = \alpha e^{-k_1 t} + (1 - \alpha) e^{-k_2 t}$$

where k_1, k_2 , and α can be graphically estimated.

One of the variables as a function of aging time was α , the fraction which is characterized by the faster rate constant (k_1). It was previously proposed, to interpret α as reflecting the fraction of free volume above a certain critical size which is necessary for the photochrome label to isomerize. In the molecular theory of physical aging based on rotation around short segments of the polymer main chain, it was suggested that the initial fast volume relaxation is due to relaxing molecular rearrangements in regions of particularly high free volume produced by thermal fluctuations. As physical aging proceeds, α decreases, reflecting the collapse of such large free volume. This suggests that free volume distribution is skewed toward smaller sizes after aging. It was previously established that above T_g , the thermal back reactions obeyed a single first-order rate, leading to the conclusion that the biphasic rates in glass were due to inhomogeneities in the density of the glass at the molecular level. In the case of spiropyrans, where different isomers of the open merocyanine form exist, the deviations from first order kinetics observed in glassy polymers are due to both effects of different stereoisomers and of non-equilibrium distribution of free volume. The restrictions for the ring closure reaction greatly depend on the steric requirements of the given stereoisomer and therefore on the actual mobility of the chromophore which internally depends on the nature of the given polymer. Chain segmental relaxation processes, which depend on the local environment of the chromophore, are the controlling factors for the isomerization. The relaxation of the chromophore requires local conformational changes of chain segments for the

reaction to proceed, and these are controlled by the local fraction of the total free volume. All these factors suggest that α could be used as a sensitive metric of free volumes or holes present in the solid matrices under investigation. Thus, since physical aging leads to densification of the polymeric structures, reducing the amount of free volume. Thus, the photochromic labels can provide quantitative information on the structural changes occurring in polymeric solids due to physical aging.

Based on the research accomplished, it is evident that the proposed technique could be used for characterization of the physical aging on the molecular level in polymeric structures. Applied to material of construction for aircraft canopies, it could be a powerful tool in prevention of catastrophic failure with time and temperature.

7. CONCLUSIONS

1. Employment of photochromes allows quantification of physical aging of polymers.
2. Application of different size probes can be used to "map" the distribution of spatial fluctuations in canopy-graded materials and to study the perturbation of this distribution with applied stress.
3. Evaluation of the effect of physical aging on mechanism and time of crack initiation under particular service conditions would give one a powerful diagnostic tool to prevent the catastrophic failure of canopies.

8. FUTURE WORK

Future work will involve the use of different size probes and molecular modeling to "map" the distribution of spatial fluctuations in polycarbonate and perturbation of the distribution with applied stress.

9. ACKNOWLEDGEMENT

The authors acknowledge financial support of this work by the Air Force Office of Scientific Research. Helpful discussions and encouragement by Dr. C.P. Bosnyak from the Dow Chemical Company are gratefully acknowledged.

10. REFERENCES

1. G.H. Brown, "Photochromism", Techniques of Chemistry, V.3, Wiley-Interscience Publ., 1971
2. C.P. Bosnyak, J.K. Rieke, V. Krongauz, A. Chudnovsky, "Using Spiropyran as a Molecular Probe for the Deformation of Polycarbonate", 7th International Conference "Deformation, Yield and Fracture of Polymers", Cambridge, England, 1988
3. L. Lamare, C.S.P. Sung, "Studies of Physical Aging and Molecular Motion by Azochromic Labels Attached to the Main Chains of Amorphous Polymers", *Macromolecules*, 1983, 16, 1729-1736
4. E. Goldburt, V. Krongauz, "A Simple Relationship between Rate of Color Change and Molecular Weight of a Photochromic Spiropyran Polymer", *Macromolecules*, 1986, 19, 246-247
5. T. S. Chow, "Kinetics of Free Volume and Physical Aging in Polymer Glasses", *Macromolecules*, 1984, 17, 2336-2340
6. C. D. Eisenbach, "Relationship between Photochromism of Chromophores and Free Volume in Bulk Polymers", *Phys. Chem.*, 1980, 84, 680-690
7. J. G. Victor, J. M. Torkelson, "On Measuring the Distribution of Local Free Volume in Glassy Polymers by Photochromic and Fluorescence Techniques", *Macromolecules*, 1987, 20, 2241-2250

8. K.Y. Law, R.O. Loutfy, "Spectroscopy of Dyes in Polymeric Matrices: Dual Fluorescence of [p-(Dialkylamino)benzylidene]malononitrile Dye in Poly(vinylacetate) Matrices, *Macromolecules*, 1981, 14, 587-591
9. K.Horie, M. Tsukamoto, I. Mita, "Photochromic Reaction of Spiropyran in Polycarbonate Film", *Int. Polym.J.*, 1985, Vol.21, No. 9, 805-810
10. G.J. Smets, J. Thoen, A. Aerts, "Some Photochemical Reactions in Solid Polymer Systems", *Polymer Sci.*, Symposium No. 51, 1975, 119-134