

S)	
IING ORGANIZATION NAME(S) AND ADDRESS(ES) IN KNUDSEN CORPORATION :R, CO	8. PERFORM REPORT 95:
RING/MONITORING AGENCY NAME(S) AND ADDRESS(ES)	10. SPONSOR AGENCY

DISTRIBUTION STATEMENT A
 Approved for public release
 Distribution Unlimited

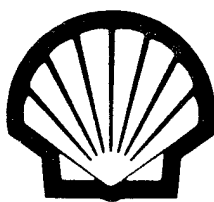

Shell Oil Company

19960509 011

REPORT DOCUMENTATION PAGE

Form Approved
OMB No. 0704-0188

Public reporting burden for this collection of information is estimated to average 1 hour per response, including the time for reviewing instructions, searching existing data sources, gathering and maintaining the data needed, and completing and reviewing the collection of information. Send comments regarding this burden estimate or any other aspect of this collection of information, including suggestions for reducing this burden, to Washington Headquarters Services, Directorate for Information Operations and Reports, 1215 Jefferson Davis Highway, Suite 1204, Arlington, VA 22202-4302, and to the Office of Management and Budget, Paperwork Reduction Project (0704-0188), Washington, DC 20503.

1. AGENCY USE ONLY (Leave blank)	2. REPORT DATE <p style="text-align: center;">07/07/95</p>	3. REPORT TYPE AND DATES COVERED	
4. TITLE AND SUBTITLE ENHANCED DEEP SOIL VAPOR EXTRACTION PROCESS (EDSVEP) TREATABILITY STUDY REPORT		5. FUNDING NUMBERS	
6. AUTHOR(S)		8. PERFORMING ORGANIZATION REPORT NUMBER <p style="text-align: center;">95201R01</p>	
7. PERFORMING ORGANIZATION NAME(S) AND ADDRESS(ES) MORRISON KNUDSEN CORPORATION DENVER, CO			
9. SPONSORING/MONITORING AGENCY NAME(S) AND ADDRESS(ES) SHELL DEVELOPMENT COMPANY DENVER, CO		10. SPONSORING/MONITORING AGENCY REPORT NUMBER	
11. SUPPLEMENTARY NOTES			
12a. DISTRIBUTION/AVAILABILITY STATEMENT APPROVED FOR PUBLIC RELEASE; DISTRIBUTION IS UNLIMITED		12b. DISTRIBUTION CODE	
13. ABSTRACT (Maximum 200 words) THIS REPORT DETAILS THE FINDINGS OF THE ENHANCED DEEP SOIL VAPOR EXTRACTION PROCESS (EDSVEP) TREATABILITY STUDY. IT IS ORGANIZED AS FOLLOWS: SECTION 1.0 INTRODUCTION. SECTION 2.0 TECHNOLOGY DESCRIPTION. SECTION 3.0 TREATABILITY STUDY APPROACH. SECTION 4.0 RESULTS AND DISCUSSION. SECTION 5.0 EVALUATION. SECTION 6.0 CONCLUSIONS AND RECOMMENDATIONS. APPENDIX A RMA COMPLETION RECORDS. APPENDIX B FIGURES AND TABLES. <p style="text-align: right; font-weight: bold; font-size: 1.2em;">DTIC QUALITY INSPECTED 3</p>			
14. SUBJECT TERMS BENCH-SCALE TESTING, SOIL HEATING, SILICONE RUBBER COVER, VAPOR RECOVERY, COST		15. NUMBER OF PAGES	
17. SECURITY CLASSIFICATION OF REPORT UNCLASSIFIED		16. PRICE CODE	
		20. LIMITATION OF ABSTRACT	
18. SECURITY CLASSIFICATION OF THIS PAGE	19. SECURITY CLASSIFICATION OF ABSTRACT		

ENHANCED DEEP SOIL VAPOR EXTRACTION PROCESS (EDSVEP)
TREATABILITY STUDY REPORT

Prepared by
Morrison Knudsen Corporation
Environmental Services Group

and

Shell Development Company

Prepared for
Holme Roberts & Owen^{LLC}/Shell Oil Company
Denver, Colorado

July 7, 1995

DTIC QUALITY INSPECTED 3

07/07/95

TABLE OF CONTENTS

EXECUTIVE SUMMARY	iv
1.0 INTRODUCTION	1
1.1 BACKGROUND	2
1.2 SITE CONDITIONS	3
1.3 STUDY OBJECTIVES	4
2.0 TECHNOLOGY DESCRIPTION	5
2.1 TEST SYSTEM SUBSURFACE CONFIGURATION	5
2.1.1 Injection Vent	6
2.1.2 Extraction Vents	7
2.1.3 Monitoring Probes	8
2.1.4 Thermocouple and Sampling Point Distribution	8
2.2 AIR INJECTION SYSTEM	9
2.3 VAPOR RECOVERY AND TREATMENT SYSTEM	9
2.3.1 Extraction Vent Flow Metering	10
2.3.2 Air/Water Separation System	11
2.3.3 Extraction Flow and Vacuum Control	11
2.3.4 Carbon Adsorbers	12
2.3.5 Vacuum Blowers	13
2.3.6 Air Exhaust	13
2.4 HEATING ELEMENT AND CONTROL PANEL	13
3.0 TREATABILITY STUDY APPROACH	15
3.1 PRE-TEST SOIL SAMPLING	15
3.2 BENCH-SCALE TESTING	16
3.3 HELIUM TRACER TEST	17
3.3.1 Tracer Test Methodology	17
3.4 FIELD TEST OPERATION	18
3.4.1 Soil Heating	18
3.4.2 Vapor Recovery	19
3.4.3 Soil Gas Flow Distribution	20
3.4.4 Heating System Monitoring	20
3.4.5 Silicone Rubber Cover	20
4.0 RESULTS AND DISCUSSION	21
4.1 PRE-TEST SOIL SAMPLING	21
4.1.1 Physical Properties	21
4.1.2 Chemical Analysis	21
4.3 HELIUM TRACER TESTS	22
4.3.1 Tests Prior to Heating	22
4.3.2 Tests in Heated Uncovered Soils	23
4.3.3 Tests in Heated and Covered Soils	23

4.4	FIELD TEST OPERATION	24
4.4.1	Soil Heating	24
4.4.2	Vapor Recovery	26
5.0	ECONOMIC EVALUATION	28
5.1	SITE AND SYSTEM OPERATING CONDITIONS	28
5.1.1	Soil Characteristics	28
5.1.2	Site Configuration and Dimensions	29
5.1.3	Treatment Summary	29
5.1.4	Vapor Collection and Treatment System	31
5.2	CAPITAL COST ESTIMATES	31
5.2.1	Vapor Collection and Treatment System	31
5.2.2	General Facilities	32
5.2.3	Operating Costs	32
5.2.4	Operating Cost Summary	32
6.0	CONCLUSIONS AND RECOMMENDATIONS	34

FIGURES

TABLES

APPENDICES

EXECUTIVE SUMMARY

A treatability study was conducted to evaluate whether the Enhanced Deep Soil Vapor Extraction Process (EDSVEP) is practicable for the removal of low volatility compounds from unsaturated subsurface soils. Test results indicate that EDSVEP may be an effective in situ alternative for the remediation of subsurface soils contaminated with low volatility compounds. However, depending on site-specific conditions and remediation goals, this technology should be fully compared with other remedial alternatives. Based on the treatability study results, preliminary evaluation and economic analysis of a full-scale system has been provided.

Based on the tested operation of the system, soils may be effectively heated using this technology. The rate at which soils are heated will depend on site-specific conditions (e.g., soil permeability, soil heat capacity, soil moisture, contaminant type), operating conditions (e.g., injection air flow rate, heating element temperature), and possibly climatic conditions (e.g., precipitation events).

An objective of this study was to determine the appropriate balance between extraction and injection flow rates such that the injection rate may be maximized while containing and recovering the injected air. Helium tracer tests were utilized to evaluate the subsurface flows and injected air recovery rates. The helium tracer tests proved to be a useful tool for evaluating subsurface flow conditions and determining the appropriate flow ratios. In addition, tracer tests conducted during soil heating were used to improve operating conditions as the test progressed.

During soil heating, a silicone rubber cover was placed over the site in an attempt to better control flow conditions. Results indicate the cover is an effective vapor barrier, allowing the system to be operated at higher injection rates and lower extraction to injection flow rate ratios. The increased injection rates improved the soil heating efficiency.

Extracted vapor concentrations increased during operation of the test system. The elevated vapor concentrations may be attributed to two mechanisms. Firstly, the water table was significantly high at the outset of the test and the water table was drawn down by pumping. The groundwater depression pumping exposed soils residually saturated with contaminants which had previously been beneath the water table, thereby increasing the amount of contaminant for volatilization. Secondly, soil heating has been effective, increasing the ambient temperature and the rate at which residual contaminants desorb.

Operation of the test system has demonstrated the operability of the process and the durability of the equipment. The test system primarily utilized off-the-shelf equipment to demonstrate the implementability of this technology. The heating elements work well when operating within the manufacturer's specified range, and the control system is effective for maintaining operating conditions.

Based on the test results, a preliminary scale up design has been developed and treatment cost estimates computed. Costs for this technology are expected to range from \$120 to \$200 per ton of contaminated soil. However, the basis for this evaluation is preliminary and should be cautiously used when extrapolating to other sites or conditions.

1.0 INTRODUCTION

In a previous treatability study report, a treatability study to evaluate the enhancement of conventional soil vapor extraction (SVE) by increasing the in situ soil temperature¹ was outlined. This report details the findings of the Enhanced Deep Soil Vapor Extraction Process (EDSVEP) Treatability Study.

The intent of this report is to present the findings from this treatability study. For comparative purposes, it is essential that technologies be evaluated on the same basis. Consider for example, the overall costs for remediating a specified volume of contaminated soil using either an ex situ or in situ process. For ex situ treatment, the contaminated soils must be excavated, transported, possibly staged or processed, treated, disposed, and the site reclaimed or revegetated. In addition, other waste streams (e.g., ash from incinerator, off-gas from thermal desorber, or solution from soil washing) will require treatment or disposal. For a specified soil volume, the costs associated with each step will, in essence, remain constant, except those associated with excavation. Excavation costs will increase as the depth to contaminated soil increases. This is especially true when there are uncontaminated soils overlying the contamination zone, and the volume of clean materials which need to be removed increases with depth. An in situ process such as EDSVEP requires the subsurface components, above ground process and treatment equipment, utilities, and possibly the treatment or disposal of secondary waste streams (e.g., condensate). For the same soil volume as the ex situ case, the process equipment and treatment costs are basically constant. However, the technology

¹ Shell Oil Company, Technical Evaluation, LNAPL Plume Soil Vapor Extraction (SVE) Process Field Demonstration Treatability Study, May 1992.

becomes more efficient at depth (e.g., greater vent spacing, less heat loss to the surroundings or infiltrating air). Therefore, at depth an in situ process may be more economical than an ex situ one. The findings outlined in this report should allow for a more detailed evaluation of EDSVEP as compared to other technologies.

1.1 BACKGROUND

An original treatability study was conducted during the Spring of 1991 to evaluate whether SVE was an applicable technology for the potential remediation of contaminated unsaturated Denver Formation soils or for the removal of the South Tank Farm light nonaqueous phase liquid (LNAPL) constituents from contaminated soils.¹ The treatability study included, but was not limited to, an air permeability test, characterization of the LNAPL, and analysis of soil gas samples. Significant conclusions from this treatability study include:

- The weathered portion of the unsaturated Denver Formation is sufficiently permeable to sustain adequate air flow rates for the implementation of conventional SVE.
- Given the relatively low volatility of the principal LNAPL constituents (DCPD and substituted DCPD compounds), conventional SVE would require an extended period of operation for the removal of these contaminants from soils.

The results of the LNAPL SVE Treatability Study indicate that increasing the ambient soil temperature would enhance the removal of LNAPL compounds when utilizing conventional SVE. To evaluate whether in situ air/deep soil heating may be effectively applied to RMA site soils, the EDSVEP portion of the original LNAPL SVE Treatability Study was proposed.

1.2 SITE CONDITIONS

The test site is located within the berm for Tank 464A in the South Tank Farm. Within the berm, the ground surface is relatively flat. The site consists of an alluvium layer (about 4 ft. thick), which is underlain by the weathered upper portion of the Denver Formation. The water table was approximately 12-13 feet below ground surface (bgs) when the test was initiated and located within the weathered Denver Formation. Usually, there is a thin LNAPL layer overlying the water table, depending on the water table elevation.

Soil sampling during the LNAPL SVE investigations indicated that the majority of contaminants were slightly above the water table. The soil contaminant distribution appears to be due to the spreading of the LNAPL plume and the subsequent smearing due to water table fluctuations.

At the outset of the EDSVEP test, the water table was extremely high (<10 ft bgs). The elevated water table was most likely due to the above normal precipitation. To enable operation of the test system, the water table was drawn down by pumping from the previously installed product recovery well (Well No. 01618). Figure 1 illustrates the site conditions once the water table had been drawn down.

A detailed description of the site history, geology, hydrology, and contaminant distribution is provided in the LNAPL SVE report. Therefore, only information which is necessary for the purposes of this report has been included.

1.3 STUDY OBJECTIVES

The overall objective of the EDSVEP field test was to evaluate whether this technology is practicable for the removal of low volatility compounds from unsaturated subsurface soils. The purpose of the test was to demonstrate whether soils can be heated sufficiently in situ to effect the volatilization and removal of low volatility compounds. Specific objectives for this study include:

- Determine the appropriate balance between injection and extraction rates;
- Determine the extent to which soils may be practicably heated and the rate at which the soils are heated;
- Qualitatively determine whether mass removal rates may be enhanced when the soils are heated; and
- Develop design criteria (e.g., vent spacing, energy requirements) and economic estimates for implementation.

2.0 TECHNOLOGY DESCRIPTION

EDSVEP is an extension of conventional SVE. In addition to standard vapor recovery vents, heated air injection vents are utilized to introduce heated air into the subsurface. Given the "push-pull" configuration, soils will gradually be heated as the heating front advances. The contaminants in the soils along the heating front are desorbed and the vapors collected by the vacuum extraction system. The rate at which the soil is heated may control the rate of remediation, thus the goal is to balance the air injection and extraction rates such that air injection is maximized while insuring that the injected air is captured by the extraction vents. Maximizing air injection optimizes the rate at which heat is input to the subsurface. This technology will likely be appropriate for contaminated soils lying below ground surface and above water saturated soils (e.g., groundwater, perched water, capillary fringe zones).

The EDSVEP test system is comprised of numerous components. For the purposes of this description, the components have been grouped into four systems: 1) Subsurface; 2) Air Injection; 3) Vapor Extraction and Treatment; and 4) Heating Element and Control Panel. Provided below are descriptions of these systems.

2.1 TEST SYSTEM SUBSURFACE CONFIGURATION

The EDSVEP test system consists of one centrally located injection vent (IV) surrounded by four extraction vents (EVs) (Figure 2). This will be referred to as the 5-spot configuration. The distance between EVs is 14 feet, with a distance of 10 feet between the IV and any of the EVs. The IV is equipped with a heating element and connected to the air injection system.

The four EVs are manifolded to the vapor collection and treatment system.

Located within the test configuration are monitoring probes (MPs) used to measure temperature and soil gas pressures both vertically and horizontally (Figure 2). These probes may also be utilized to collect soil gas samples from within the soil profile during system operation.

The 5-spot configuration was selected for this test to better control the recovery of injected air and minimize the possibility of uncontrolled vapor emissions through the soil surface. However, this configuration does not adequately represent a full-scale system which would be comprised of numerous 5-spot patterns. As the size of a full-scale system increases, the ratio of injection to extraction vents approaches 1 to 1. Another way of looking at the full-scale system is that each internal extraction vent will be surrounded by 4 heated injection vents. Therefore, while the test configuration represents a more effective vapor recovery configuration, it also represents a less effective configuration for heating soils.

2.1.1 Injection Vent

The first step of construction for the IV consisted of drilling an 11-inch diameter borehole to 5½ feet bgs. An 8-inch protective casing was grouted in place using a high temperature refractory cement. The borehole was then advanced to total depth (11 feet bgs) using a 7-inch hollow stem auger. The 4-inch stainless steel IV was then completed with the screen located between 10.4 and 7.4 feet bgs. The annulus of the borehole was filled with 6-9 silica sand from the bottom to approximately 1.5 feet above the top of screen. Then about 1 foot of 100 mesh silica sand was installed as a barrier instead of bentonite

07/05/95

because the sand was not expected to desiccate under the test conditions. High temperature refractory cement was used to seal the borehole to the surface. Refer to the RMA Well Completion Records in Appendix A for more detailed information on the IV completion.

The injection vent is connected by 2-inch carbon steel pipe to the air injection system. A ball valve between the vent head and the air injection system is used to isolate the IV, if necessary.

2.1.2 Extraction Vents

The EV boreholes were advanced to depth (between 11 and 12 feet bgs) using a 7 $\frac{3}{4}$ -inch diameter hollow stem auger. The 2-inch stainless steel EVs were completed with the screens between approximately 11 and 8 feet bgs. The annulus of each borehole was filled with 6-9 silica sand from the bottom of the borehole to approximately 6 inches above the top of screen. Approximately 2 feet of 100 mesh silica sand was placed as a barrier. The borehole was then filled to the ground surface with a Portland cement/bentonite mixture. Refer to the RMA Well Completion Records in Appendix A for more detailed information on the EV completion.

Each EV is connected by 2-inch stainless steel pipe to the vapor recovery and treatment system. A ball valve between the vent head and the vapor recovery system is used to isolate the individual EVs, if necessary.

2.1.3 Monitoring Probes

Twenty-four (24) MPs were installed at the locations and depths shown on Figure 2. Twenty-three of the MPs are constructed of ¾-inch stainless steel and the twenty-fourth is a 2-inch well point. The shallow MPs (approximately 3 and 6 feet bgs) were driven with a 140-pound jar hammer. Due to the hardness of the Denver Formation, a 2½-inch diameter pilot hole was drilled with a solid stem auger to approximately 2 feet above the designed completion depth for the deep MPs (approximately 9 and 11½ feet bgs) prior to driving them. The probes were driven to approximately 6 inches below the design depth and pulled back out to the design depth. The well point was installed in a pilot hole and back filled with 6-9 sand to approximately 6 inches above the top of screen and then grouted to the surface with a cement/bentonite mixture.

2.1.4 Thermocouple and Sampling Point Distribution

Each of the monitoring points was designed to serve two purposes: 1) as a temperature measurement point; and 2) as a pressure measurement and gas sampling point.

Inconel clad, Type K, stainless steel thermocouples were installed in each of the MPs in the soil. In addition, a thermocouple was placed in the sand pack at approximately the midpoint of the screen for each EV and the IV. The IV also had a thermocouple placed approximately 4 feet bgs within the cement between the vent casing and the protective outer casing. Figure 2 illustrates the locations and numbering of the 30 thermocouples.

Each MP, EV, and the IV is equipped with a sampling port. In addition, several locations on the process skid (air injection

and vapor recovery systems) and the gas treatment system also have sampling ports. Either ¼-inch stainless steel or polyflo tubing is used to connect the numerous sampling locations to their respective sampling points, located within an onsite structure.

2.2 AIR INJECTION SYSTEM

The air injection system is mounted on the test skid (Figure 3). Air is injected by a rotary positive displacement type blower (Blower B-501). Air flow and injection pressure is regulated by opening the hand valve HV-502. The injection pressure and flow rate is reduced from the maximum capacity of the blower by exhausting to the atmosphere.

The injected air passes through a rotameter flow indicator (FI-501) which measures flow rate in acfm under design conditions. Temperature and vacuum readings are measured from temperature indicator TI-501 and pressure indicator PI-501, to correct the flow indicator reading into scfm.

Protection for the blower is provided in case of blocked outlet conditions. A high pressure switch (PSH-501) will stop the blower if the discharge pressure exceeds 5 psig. A second level of protection is the pressure relief valve (PSV-501) which releases if the blower discharge pressure exceeds 6 psig.

2.3 VAPOR RECOVERY AND TREATMENT SYSTEM

The vapor recovery and treatment system consists of various components which are part of the skid unit. Each of the primary components is described below.

2.3.1 Extraction Vent Flow Metering

Each EV is individually connected to the vapor recovery system in order to be able to control and measure the extraction vacuum or flow rate at the specific vents. The system consists of four individual flow metering runs, one for each of the four EVs. Each metering run consists of:

- An orifice plate (FE-101, 102 ,103 & 104);
- A magnehelic gage to measure the differential pressure drop across the orifice (DPI-101, 102, 103 and 104);
- A temperature indicator (TI-101, 102, 103 and 104);
- A pressure indicator (PI-101, 102, 103 and 104);
- A hand operated butterfly valve (HV-101, 102, 103 and 104).

Flow rate from each EV can be throttled using the hand operated butterfly valve. As the valve is closed, flow rate from the well will decrease. The well head vacuum will also decrease as the valve is closed. Therefore, HV-101, 102, 103 and 104 can be used to select the desired flow rate and vacuum for each extraction well.

After the metering runs, the extracted flow is manifolded into a single feed stream for the remainder of the vapor recovery and treatment system.

2.3.2 Air/Water Separation System

The Air/Water Separation system consists of passing the extracted vapors through an air cooler then into a knockout pot which acts as an Air/Water Separator. The air cooler outlet temperature can be measured by temperature indicator TI-105.

The Air/Water Separator (S-201) is used to separate free water from the extracted gas stream. Significant quantities of water can be condensed from the soil gas because of the cooling of the gas stream. Water removed in the S-201 drains into a drain sump (T-201).

2.3.3 Extraction Flow and Vacuum Control

Soil gas exiting the Air/Water Separation system passes through a rotameter (FI-201) which measures flow rate in scfm under design conditions. This measurement is for the combined flow of the EVs and is used as a check to compare the sum of the individual EV flow rates. To correct the flow indicator measurement for the process conditions, temperature and vacuum readings are measured from temperature indicator TI-201 and pressure indicator PI-201.

Downstream of the rotameter is an air bleed line. The overall system vacuum and flow may be controlled by allowing ambient air to bleed into the system upstream of the vacuum pumps. To allow dilution air into the system, hand valve HV-301 is opened. This multiple position valve allows the amount of dilution air to be throttled to achieve the desired vacuum or flow conditions.

2.3.4 Carbon Adsorbers

Two Carbon Adsorbers (F-301 A/B) are used to remove organic vapors from the soil gas stream. A valve manifold is provided that allows operation of the adsorbers in any of the following configurations:

- Bypass (flow through neither adsorber);
- Adsorber A only;
- Adsorber B only;
- Parallel;
- Series A to B;
- Series B to A.

The operating mode is to have the beds in series (A to B) in order to monitor the discharge of adsorber A for breakthrough while having adsorber B on line to treat any breakthrough prior to atmospheric discharge. The two stage configuration also allows for better utilization of the carbon because the first adsorber will still have significant adsorption capacity remaining after breakthrough.

Gas conditions at the inlet and outlet of the carbon adsorbers are monitored with the following instruments:

- TI-301 measures carbon inlet temperature;
- PI-301 measures carbon inlet vacuum;
- TI-401 measures carbon outlet temperature;
- PI-401 measures carbon outlet vacuum;
- DPI-301 measures the pressure drop across the carbon adsorbers.

Flow rate of the carbon adsorber exhaust stream is measured using an annubar flow element (FE-401) equipped with an Eagle Eye meter which provides a direct reading in scfm under design conditions.

2.3.5 Vacuum Blowers

The vacuum extraction system may be operated using one or both of the vacuum blowers (B-401A or B). The blowers are rotary positive displacement vacuum pumps. A vacuum relief valve (PSV-401) is mounted on the inlet piping to the vacuum blowers to protect them from a blocked inlet situation. The relief valve will open if the inlet vacuum exceeds 15 inches of mercury (in Hg). Two Pressure Relief Valves (PSV-402 A/B) are located in the piping immediately downstream of each of the two Vacuum Pumps to protect them from a blocked outlet condition. The relief valves will open when the Vacuum Pump discharge pressure exceeds 2 psig.

2.3.6 Air Exhaust

Flow from the vacuum system passes through separate Discharge Silencers (S-401 A/B) before being discharged to the atmosphere. The exhaust gas is discharged through a stack which is approximately 20 feet above ground surface. The temperature of the exhaust air is measured by temperature indicator TI-402.

2.4 HEATING ELEMENT AND CONTROL PANEL

A 10 kW/hr hairpin heating element is located within the IV. The heating element serves to heat the injected air as well as the adjacent soil. The heating element is 13 feet in total length, with the a 9 ft heated length and the top 4 feet being cool (unheated). The element is positioned within the IV such that the bottom is approximately 6 inches above the bottom cap. Attached to the heating element are 4 thermocouples, one of which

is used as the temperature controller and another as overtemperature sensor (Figure 3a).

The heating element and the attached thermocouples are connected to an SCR control panel equipped with an electronic PID temperature controller and overtemp shutdown. The control panel is also equipped with two digital temperature readout devices. The first is used to monitor the temperatures measured by the 4 thermocouples attached to the heating element. The second is used to display the temperatures measured at the 30 monitoring locations of the subsurface system.

A wattmeter is connected to the power supply for the heating element to measure the amount of energy put into the soil.

3.0 TREATABILITY STUDY APPROACH

The EDSVEP field test was designed specific to the test site adjacent to Tank 464A in the South Tank Farm. This program consists of the following components: 1) pre-test soil sampling and vent installation; 2) bench-scale testing; 3) helium tracer tests; and 4) field system operation and monitoring. Each of these components is described in the following sections.

3.1 PRE-TEST SOIL SAMPLING

Soil samples were collected from the boreholes drilled for the EVs and from the borehole for the IV. The soil samples were collected to characterize contamination in site soils.

Boreholes were drilled using either 7-inch or 7¼-inch diameter hollow-stem augers equipped with a 2.375-inch diameter continuous sampler. Sediment cores were collected in polybutyrate tubing within the sampler. Soil samples were collected for the intervals shown on Table 3-1. After each sample was collected, the sample barrel was raised to the ground surface, the polybutyrate tubes containing the samples removed, and the samples sealed. Following any necessary decontamination, new sample tubes were placed inside the sample barrel and the boring advanced to the next sampling depth. Decontamination of the sample barrel was accomplished by steam cleaning.

Table 3-1 Sample locations, depths (in feet), and types.

ANALYSIS	EV-1	EV-2	EV-3	EV-4	IV-1
Chemical	6.5 - 7	6 - 6.5	6 - 6.5	5 - 5.5	5.5 - 6
	7.6 - 8	7 - 7.5	7.5 - 8	6 - 6.5	7 - 7.5
	8 - 8.5	8.5 - 9	8 - 8.5	7.5 - 8	9.5 - 10
	10.5 - 11	9.5 - 10	9 - 9.5	8 - 8.5	
		11 - 11.5	10.5 - 11	8.5 - 9	
			10 - 10.5		
Physical	7 - 7.6	7.5 - 8.5	6.5 - 7.5	6.5 - 7.5	6 - 7
	9.5 - 10.5	10 - 11	9.5 - 10.5	9 - 10	
Thermal Stripping	8.5 - 9.5				10 - 11

Samples extracted from the sample barrel were prepared for temporary storage and shipment by placing a Teflon sheet over the ends of the polybutyrate tubes. To provide a seal, plastic caps were placed over the Teflon and secured with duct tape. The samples were labeled, indicating which end was the top of the sample, the sample depth, and borehole number. Sealed polybutyrate tubes were placed in coolers and packed in styrofoam and blue ice to maintain sample integrity during storage and shipment.

3.2 BENCH-SCALE TESTING

Bench-scale studies were conducted at Shell Development Company's Westhollow Research Center to determine the efficacy of in situ soil heating. The initial test configuration consisted of a "sandbox" (approximately 3'x 3'x 3') which contained fine to medium sands, and had two extraction vents at one end and two

passive injection heating vents at the opposite end (Figure 4). The passive injection heating vents were open to the atmosphere, therefore, any air flow past the heating element within the vent was induced by the vacuum extraction process. Thermocouples were distributed throughout the soil profile to measure the soil temperature changes. Follow up tests included placement of a silicone rubber sheet beneath the soil surface to effectively seal the surface surrounding the extraction vents and minimize "short-circuiting."

The purpose of the bench-scale test was to estimate appropriate heater spacing and power requirements for the field test. The results were also utilized to develop preliminary economic estimates for the technology.

3.3 HELIUM TRACER TEST

EDSVEP requires heat transfer from the IV into the surrounding soil by convection of the heated injection air. Therefore, an initial operational goal for the test was to maximize the rate at which air was injected while ensuring that the injected air was fully recovered. To determine the appropriate ratio of air extraction to air injection rates ($Q_{\text{ext}}/Q_{\text{inj}}$), a series of helium tracer tests were conducted.

3.3.1 Tracer Test Methodology

The primary method for the tracer tests was a mass balance between the injection and extraction gas streams when the system was under steady-state conditions. Helium was introduced into the injection air stream and helium concentrations were measured in the extraction streams. Knowing the rate at which helium was injected and measuring the rate at which it was recovered (computed from the extraction flow rates and gas concentrations),

the recovery rate could be determined. Figure 5 illustrates the helium tracer test sampling system.

Prior to introducing the helium into the injected air stream, the flow rate was measured on a rotameter which was calibrated for the mass flow rate. To verify conservation of mass in the injected air stream, helium concentrations were measured in samples collected from the air injection system and at the head of the IV. Based on these measurements, the injected mass flow rate of helium was determined.

Helium recoveries were determined by measuring concentrations in both the individual EVs and the total extraction flow within the recovery and treatment system. To verify the mass of helium recovered by the extraction system, the sum total mass of helium in each EV was compared with the mass of helium within the total extraction flow of the recovery and treatment system. The soil gas pressures were also measured as indicators of subsurface flow patterns.

3.4 FIELD TEST OPERATION

3.4.1 Soil Heating

The heating element was started on July 28, 1992. The temperature controller was set at 1550°F and the overtemp at 1750°F. The initial injection rate was set according to the ratios established during the tracer tests (approximately 5 scfm injection and 20 scfm extraction). These operating conditions were maintained for an extended period.

The system was monitored regularly and operating conditions recorded in a field logbook. The system operated 24 hours a day and was attended to during the daytime. Based on the site and

07/05/95

observed operating conditions, the mode of operation was easily adjusted.

The system was periodically shut down for maintenance. In addition, since the system was not attended to around the clock, there were several safety and equipment protection interlocks which would temporarily shut down the system or a portion thereof, if necessary. The reason and duration of system shut down are recorded in the field logbook.

3.4.2 Vapor Recovery

Total organic vapor concentrations were monitored regularly by sampling with a Ratfisch Flame Ionization Detector (FID), an Organic Vapor Analyzer (OVA) or laboratory sample analysis. The FID and OVA were calibrated to a methane in air standard and zeroed using zero air. Samples were collected from the sampling points of either the subsurface system or the vapor recovery and treatment system.

Organic vapor concentrations were measured in each of the individual extraction vents, in the total undiluted air stream on the process skid, in between the carbon beds, and at the exhaust stack. The monitoring results are recorded in a field logbook. Confirmatory samples were collected in Tedlar bags and analyzed in the laboratory at WRC. The primary purpose of the vapor monitoring was to monitor breakthrough of the primary carbon bed. Influent concentrations were used to monitor carbon loading and the exhaust concentration to demonstrate the treatment system operated as expected.

3.4.3 Soil Gas Flow Distribution

The soil gas flow distribution was determined by measuring both the soil gas pressures and the individual extraction flow rates and vacuums. Extraction rates were measured on the individual extraction vent metering runs, and the soil gas pressures were measured using magnehelic gages connected to the sampling points. These data are recorded in a field logbook.

3.4.4 Heating System Monitoring

The heating system was monitored regularly for both power input and temperature. The power input was measured on a wattmeter which measured the power to the heating element. Temperatures were logged by an automated data collection system and recorded regularly in a field logbook. The temperatures were measured from the digital display on the heater control panel.

3.4.5 Silicone Rubber Cover

A silicone rubber cover was placed over the site on October 9, 1992. The cover was put down in an effort to better control the air flow rates. The cover is approximately 24 ft x 24 ft, covering about 5 ft beyond the grid of the extraction vents. The cover was sealed with a high temperature silicone caulk. Once the cover was in place, it was covered with 4-6 inches of clean soil.

4.0 RESULTS AND DISCUSSION

4.1 PRE-TEST SOIL SAMPLING

4.1.1 Physical Properties

Table 4-1 lists the results of the physical properties testing for the pre-test soil samples. These results are similar to those of the original LNAPL SVE Treatability Study.

4.1.2 Chemical Analysis

Table 4-2 lists the results of the soil sample chemical analyses. In general, the samples showed very low to nondetectable contaminant levels. These results are consistent with the findings of the LNAPL SVE soil sampling program. At the time the soil sampling program was implemented for this treatability study, the water table was significantly higher than that of the original LNAPL SVE treatability study. Therefore, relative to the respective water tables the results of the two sampling events may appear to be different. However, when comparing the elevations of the samples the results are similar. These results further support the conceptualization that the primary mechanism for distributing contaminants in the site soils is the fluctuating water table.

4.2 BENCH-SCALE TESTING

The experimental results of the initial bench-scale tests indicated that air infiltration to the soil due to "short-circuiting" and heat loss to the surroundings had a significant effect on soil heating rates. In order to input the amount of heat required to effectively implement this technology, the soils

will need to be heated by convection. To maximize the convective heating of soils an active IV would be required, in addition to conduction as opposed to the passive IVs used in the tests.

The tests showed that initially, moist soils would heat up quickly and then level off at approximately the temperature at which water boils. However, temperatures along the heating front actually decreased prior to rising again. This phenomenon may be explained by water evaporation and condensation mechanisms.

Another observation from the bench-scale tests was that heat losses may be significant. Heat may be lost to infiltrating surface air as well as to uncontaminated soils. In addition, a large portion of the heat input was used to evaporate the soil moisture.

4.3 HELIUM TRACER TESTS

4.3.1 Tests Prior to Heating

Steady-state helium mass balances were measured at various operating conditions prior to heating of the soil (July 20 to July 30, 1992). Complete helium and thus injection air recovery was observed for extraction to injection air flow rate ratios greater than 4 to 1. This is illustrated in Figure 6 which shows the normalized helium recovery (helium in the extracted air divided by the helium in the injected air) as a function of the ratio of the extraction to injection air flow rates. Data is shown for both the total extracted air flow and the sum of the four individual flows from the extraction wells.

Another indicator of potential air loss through the soil surface was a positive pressure near the surface. Figure 7 shows the

pressure measured at monitoring point SP-3, which is the closest shallow MP to the IV, as a function of the extraction to injection air flow rate ratio. A vacuum at this point indicated no loss of air through the soil surface. For flow rate ratios greater than approximately 4 to 1 this vacuum condition was observed. These observations are consistent with the helium mass balance results shown in Figure 6. Thus, the pressure near the surface of the soil near the IV may be used as a field monitor to indicate whether there is complete recovery of injected air.

4.3.2 Tests in Heated Uncovered Soils

Steady-state helium tracer tests were repeated several weeks after the initial start up of the EDSVEP heater (see data for August 20, 1992 in Table 4-3). At this time, a significant decrease in the percent of helium recovered at a fixed flow rate ratio was observed, 40-70 percent as compared to 80-100 percent, respectively. A positive pressure at SP-3 was also observed, consistent with a loss of injected air through the soil surface. Thus, heating of the soil appeared to have significantly affected the steady-state air flow balance. This was most likely due to an increase in permeability of the soils near the heater as the moisture content was reduced.

Data from later tracer tests, when the heating front appeared to have reached the EVs, October 7 through October 9, 1992, indicate that the helium and thus the injected air recovery efficiency had returned to levels comparable to conditions prior to soil heating.

4.3.3 Tests in Heated and Covered Soils

Tracer tests were performed on October 27 through October 29, 1992 (Table 4-3). The extraction to injection air flow rate

ratio for which full recovery of injected helium and thus injected air was observed was reduced to about 2 to 1 because of the cover. This is shown by the data plotted in Figure 8. The pressure at SP-3 responded to changes in the flow rate ratio similarly to pre-cover conditions (i.e., became positive at flow rate ratios less than 4 to 1). In fact, at extraction to injection flow rate ratios below 4 to 1, all pressures at the monitoring points under the cover were found to be positive, even with full injected air recovery.

The pressure at SP-23 appears to be a better indicator of helium and thus air recovery with the cover in place, Figure 9. Full recovery was obtained as long as the pressure at SP-23 was negative. This suggests that the cover acts as an effective vapor barrier if any injected air escapes through the soil surface. The barrier forces the air to pass over the soil surface to the EVs, where it is recovered. However, as expected from previous experience, an impermeable surface cover is not effective at increasing the extent of pressure influence of the extraction vents below the soil surface.

4.4 FIELD TEST OPERATION

4.4.1 Soil Heating

Figures 10 through 12 show the temperatures which were measured at the various monitoring locations during the course of the test. Figures 13 and 14 show the temperature profiles along the two banks of monitoring probes. As may be determined from these figures, the EDSVEP system is capable of heating the site soils.

At the initially prescribed flow ratios, the power to the heating element was 5-6 kW/hr. As may be seen from Figures 10-12, the soil temperatures in the vicinity of the IV increased fairly

rapidly to approximately 180°F and leveled off until the soil moisture had been evaporated. The temperatures increased gradually once dried.

About 1000 hours into the operation of the system, the flow ratio was decreased to approximately 1 to 1. The heat input increased to 10 kW/hr, and the soil temperatures increased significantly. Under these operating conditions, the observed soil gas pressures were positive for all the shallow MPs, indicating possible vapor emissions through the soil surface. However, Health and Safety monitoring in the breathing zone at the site showed that the concentrations were below detection and those along the soil surface (within 6 inches) were low or below detection. The only detections at the soil surface occurred around the annulus of some temporary monitoring probes close in to the IV. These probes served as preferential pathways for the injected air and were subsequently abandoned.

Inspection of Figures 10-12 also shows that there are impacts due to hydrologic and meteorologic influences (meteorological data included in Appendix B). For example, on August 24, 1992 (approximately 700 hours into operation) there was a large precipitation event, approximately 2.55 inches. The system shut down because the sump tank for the knockout pot filled with water. The heat recovery was much more gradual than that observed during a previous system shutdown.

The original heating element burned out approximately 1700 hours into operation. As may be seen on Figure 10, HT3, one of the backup thermocouples attached to the heating element, exceeded 1800°F, the maximum temperature for the heating element. The replacement heating element failed one week later. Again, the failure was due to excessive temperature of the element. The elevated heating element temperatures were due to the higher air

injection rates (approximately 16 scfm). This overheating problem has been solved by using the thermocouple with the highest temperature reading as the control. The observed temperatures along the heating element vary with the injection air flow rate, therefore, as flows are adjusted the corresponding thermocouple is selected as the control.

Anticipating the possibility that a heating element might fail during the test, a methodology for changeout of heating elements was established to minimize the amount of down time. It takes approximately 1½ hours to replace the heating element. This is important because there may be large heat losses associated with an extended system shut down (>12 hours) (Figures 10-12 at about 1700 hours).

4.4.2 Vapor Recovery

Vapor concentrations were very low or non-detectible when the vapor recovery and treatment system was first operated for the tracer tests. Vapor concentrations continued to remain at these levels for the first 2 months of heating. The vapor concentrations in the extraction vents increased significantly in late September and peaked in mid-October (maximum concentration of 825 ppm on the Ratfisch). Later readings leveled off with EV1 and EV2 at 60-70 ppm, EV3 at 200-250 ppm, and EV4 at 300-330 ppm. Figure 15 illustrates the observed vapor recoveries.

The increased vapor concentrations was possibly due to a combination of the following mechanisms: 1) the groundwater depression pumping, NAPL residually saturated soils have been exposed, increasing the source for vapors; 2) the soil heating enhancing the partitioning of contaminants; and 3) decomposition of naturally occurring soil organic materials. Given that soil heating and groundwater depression has occurred simultaneously,

it is difficult to attribute the extent of enhancement to an individual mechanism.

5.0 ECONOMIC EVALUATION

The projected economics are heavily dependent on the site conditions and operating assumptions used to evaluate the process. A copy of the spreadsheet developed to estimate the base case costs is shown in Table 5-1. This spreadsheet documents the assumptions used in developing the cost estimates. The spreadsheet model computes capital equipment costs, annualized operating costs, and unit remediation costs based on the weight of contaminated soil. The following sections briefly describe the various portions of the spreadsheet model.

5.1 SITE AND SYSTEM OPERATING CONDITIONS

5.1.1 Soil Characteristics

Soil characteristics necessary for the economic evaluation include soil density, soil moisture content, soil air permeability, and contaminant concentration. Both soil density and moisture content affect the total heat input requirements for a particular site. Soil air permeability determines the rate at which air can be injected or extracted and directly corresponds to the duration of remedial activities. Total organic vapor concentrations will determine the sizing of the offgas treatment equipment.

Based on the above soil characteristics, the minimum heat required to treat one ton of contaminated soil may be determined. The minimum heat requirement is computed as the energy necessary to raise the temperature of the soil to 600°F, the average treatment temperature across the site. To compute the energy requirements, the soil heat capacity must be supplied. For our

purposes, this was 0.26 Btu/lb/F and the heat of vaporization for water used was 1000 Btu/lb.

5.1.2 Site Configuration and Dimensions

A standard full-scale module is assumed to be 100 ft x 70 ft. This is approximately the maximum module size because a single trailer-mounted recovery and treatment system is not expected to be capable of handling much greater flows. In addition, an excessive amount of piping and insulation would be required to manifold a larger system.

The assumed vent pattern was the 5-spot configuration with a spacing of 10 ft between each injection vent and the surrounding extraction vents (IVs or EVs on 14 ft centers). Any vent pattern or spacing may be used for a particular site, changing the number of IVs and Evs. The 10 ft vent spacing was selected as the optimum based on preliminary economic evaluations (Figure 16).

The extraction vents may either be made of carbon steel or PVC, depending on the desired remediation temperature at the vent. To reduce vent installation costs, a smaller diameter vent (e.g., 2-inch) is preferred. Soil air flow calculations show that a 50% reduction in well diameter results in only a 10% decrease in the air flow rate.

5.1.3 Treatment Summary

To estimate the time necessary to heat the soil to a specified remediation temperature, input to the spreadsheet includes the mass of contaminated soil, the minimum energy requirement per ton of soil, the heating efficiency, and the average heat input capacity of the system. The thickness of contaminated soils and

the areal extent of contamination define the volume of soil to be treated, and the mass is based on the soil density.

The peak heater power requirement is the total power when all the heating elements are operating at rated capacity. It is assumed that the heaters are operated 80 to 90% of capacity. The average heater power requirement is the average heat input to the soil over the heating period.

Since heat losses occur by both conduction to soils outside the treatment zone and convection through surface air infiltration, a heating efficiency is included when computing the heating time. To accurately determine a site-specific heating efficiency, it is suggested that either bench experiments or field tests be conducted, as was done during this treatability study. Preliminary evaluation of the field test data indicate the heating efficiency was approximately 40% (Figure 16a).

Other power requirements include the air injection system, the vapor recovery and treatment system, and liquid management and transferral. These requirements are estimated based on the individual stream flow rates.

To estimate the overall remediation time, the time to cool down is assumed to be 10% of time required for heating. In addition, a factor of 0.85 is assumed when computing an annual treatment rate effected by system repairs or equipment replacement and other contingencies. However, the daily treatment rate is calculated, based on the heating time only.

5.1.4 Vapor Collection and Treatment System

Included as critical design parameters are the rate at which air is injected and the vapor extraction rates for the individual vents. The average daily water and contaminant vapor flow rates are calculated from the initial soil moisture content, the extraction or injection rates, and the estimated daily soil treatment rate.

Any condensate removed from the gas stream is periodically transferred from sump tank to either a temporary storage tank or directly to a water treatment facility. It is assumed that an onsite water treatment facility will be available.

For the purposes of this cost estimate, it was assumed that granular activated carbon beds would be used for vapor treatment. However, it is expected that for the anticipated flow ranges, the annualized costs of carbon adsorption and thermal destruction should be about the same.

5.2 CAPITAL COST ESTIMATES

All costs are given in 1992 dollars. A 30% contingency factor is included on the total capital cost.

5.2.1 Vapor Collection and Treatment System

The vapor collection and treatment system is to be trailer-mounted. The assembled system cost is estimated as 150% of the sum of the costs for the individual major pieces of equipment. The total cost accounts for installation, piping, instrumentation, trailer, and labor costs. A 30% contingency factor is applied in calculating the final offgas treatment system cost.

07/05/95

5.2.2 General Facilities

The cost of the site general facilities (e.g., field offices, supply storage areas, workspace for equipment maintenance, services) is assumed to be 25% of the total capital cost, including well installation costs. It is assumed that the general facilities costs will be distributed among the various remediation technologies.

5.2.3 Operating Costs

It is assumed that each EDSVEP operating module will require one third of a single operator's time. Based on Shell's plant experience, one full time operator position (four shifts) costs \$350,000/year.

Other operating cost assumptions include \$100,000/year for analytical, \$500/vent for cleanup and decommissioning, \$0.06/Kwh electricity, and \$0.25/gal for condensate disposal. The vent cleanup cost covers disassembling the gas collection piping system, removing vents, and revegetating the site. The cost estimate for condensate disposal is based on the assumption that an onsite waste water treatment facility will be available. The maintenance costs are assumed to be 20% of the total capital costs, excluding well installation costs.

5.2.4 Operating Cost Summary

The results show that for the base case site, EDSVEP remediation costs are about \$410,000 per module (100' x 70'). This translates to approximately \$134 per ton. These costs are dependent on the assumptions and site characteristics used. The

treatment rate for the base case will be about 8,000 tons/year per module.

The unit remediation cost breakdown indicates that the highest costs are associated with the installation of the extraction and heated injection vents (including the heating element). These costs comprise approximately 27% of the total cost. Other significant costs include maintenance and capital charges on equipment (26%) and electrical power requirements comprise approximately 17%. Figure 17 shows the breakdown of the various cost components.

6.0 CONCLUSIONS AND RECOMMENDATIONS

- Given the test EDSVEP system equipment and configuration, a reasonable heating rate may be achieved. For this site and test system configuration, the heating efficiency was approximately 40 percent. It is anticipated that a full-scale system will be more efficient.
- The helium tracer tests are useful for monitoring subsurface flow. For the purposes of this treatability study, the tracer tests were useful for determining the appropriate extraction versus injection air flow ratios.
- The silicone rubber cover acted as an effective vapor barrier, enabling the system to operate at lower extraction to injection air flow ratios (e.g., increased injection flows). Due to an increased air injection rate, the heating rate improved.
- Various installation, construction, and equipment costs were verified for the site. The estimated treatment costs are approximately \$134 per ton of contaminated soil. These costs are based on observations and experience gained during the treatability study and the site characteristics assumed in the spreadsheet model. Remediation costs will vary for different site conditions (e.g., contaminants, soil types, depth to contamination, thickness of contaminated zone), but are expected to be between \$120 and \$200 per ton of contaminated soil.
- The performance of the heating elements and control systems was demonstrated. Under the manufacturer's specified operating conditions (less than 1600°F), the heating

elements will operate for extended periods. Upon exceeding capacity (1800°F), the elements will fail rapidly.

- Vapor concentrations increased during the course of this test. The observed increase may be attributed to the water table draw down, exposing residually saturated contaminated soil to air flow, and to soil heating enhancing partitioning or decomposing naturally occurring organics. However, it is difficult to quantify the degree of volatilization which may be attributed to either of these mechanisms.

Based on a preliminary review of the available results for this treatability study, it is recommended that further analyses be performed to better define the range of soil types and contaminants for which EDSVEP may be effectively utilized.

APPENDIX A

07/05/95

RMA Well Completion Record

Well Number _____ Project EDSVEP

Borehole Number EV-1 Date _____

Surveyed Location 178 070.012 N
2184 388.138 E

Surveyed Elevation GS 5265.63 ft.
TOC 5266.81 ft.

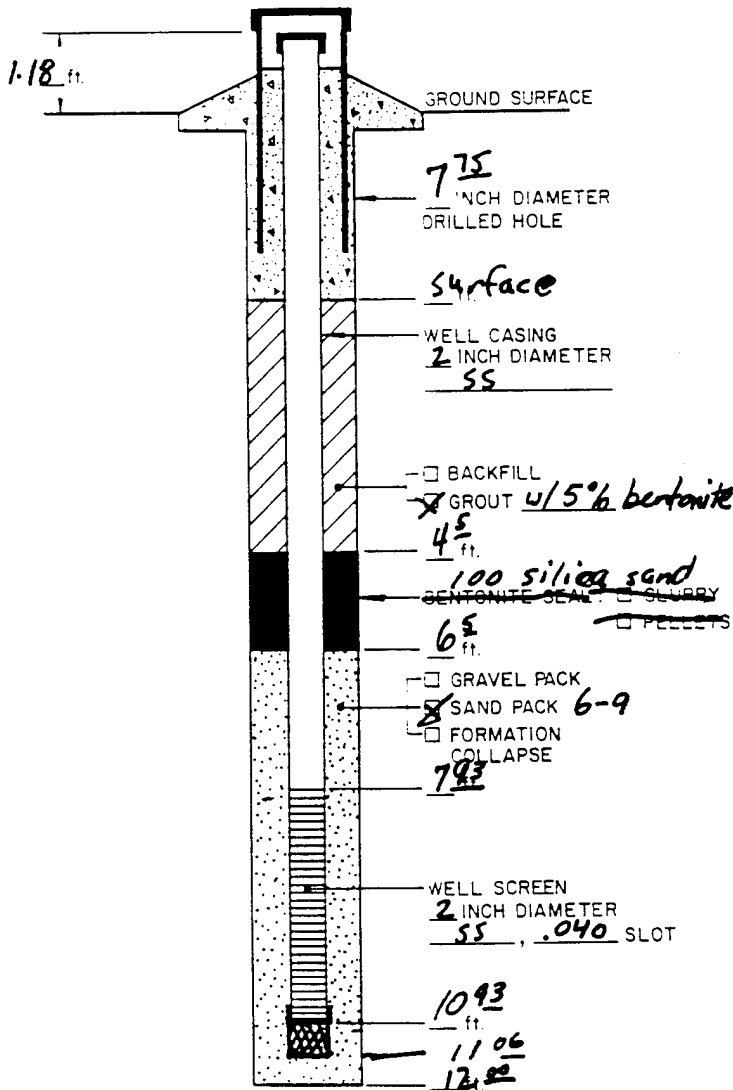

Installation Date 920415

Drilling Method Hollow Stem Auger

Drilling Contractor Layne

Drilling Fluid N/A

Development Date N/A

Development Technique N/A

Water Removed N/A gals.

Static Depth to Water N/A ft. below TOC

Comments vent was completed above the water table
- no surface casing was installed
- 100 silica sand was used instead of bentonite

Depths From Ground Surface Unless Otherwise Noted

Prepared By Peter E. Berglund

RMA Well Completion Record

Well Number _____

Project EDSVEP

Borehole Number EV-2

Date _____

Surveyed _____

Surveyed _____

Location 178 069 . 652 N

Elevation GS 5266.12 ft.

2184 401 . 644 E

TOC 5266.97 ft.

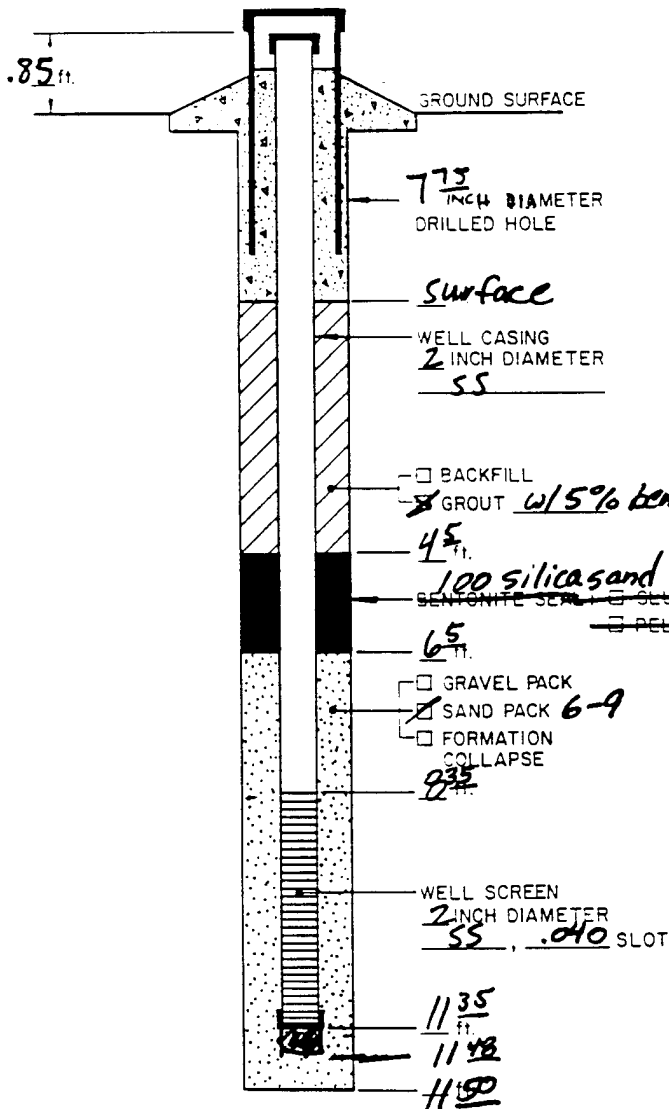

Installation Date 920417

Drilling Method Hollow Stem Auger

Drilling Contractor Layne

Drilling Fluid N/A

Development Date N/A

Development Technique N/A

Water Removed N/A gals.

Static Depth to Water N/A ft. below TOC

Comments vent was completed above the water table
- no surface casing was installed
- 100 silica sand was used instead of bentonite.

Depths From Ground Surface Unless Otherwise Noted

Prepared By Peter R Burghund

RMA Well Completion Record

Well Number _____

Project E05VEP

Borehole Number EV-3

Date _____

Surveyed Location 178 055.444 N

Surveyed Elevation GS 5265.80 ft.

2184 401.575 E

TOC 5266.70 ft.

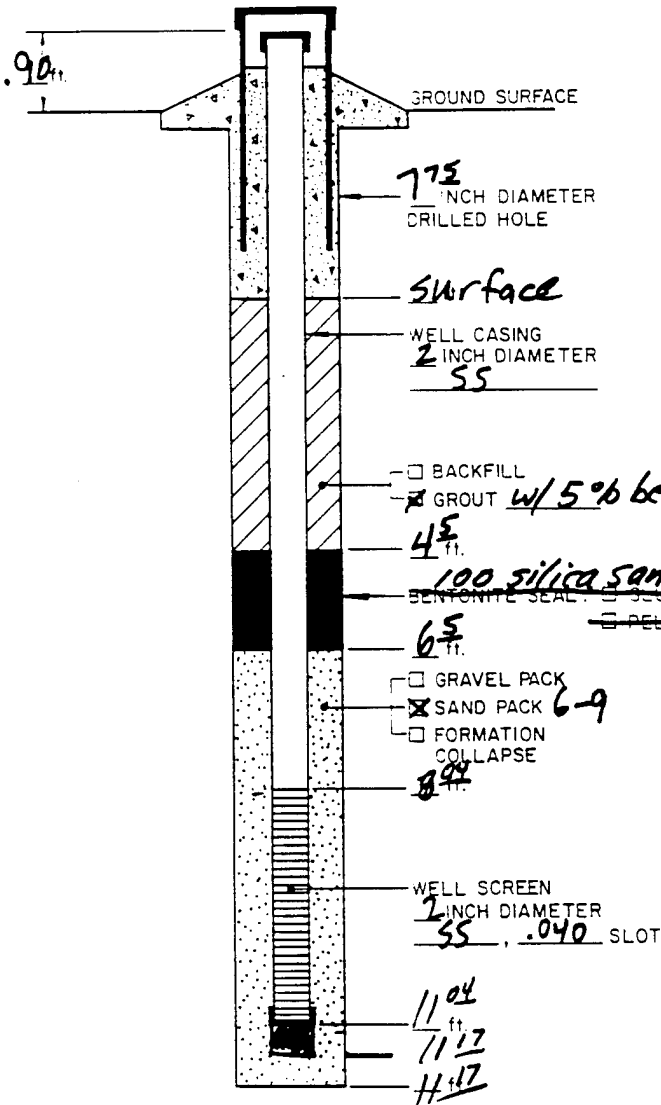

Installation Date 920416

Drilling Method Hollow Stem Auger

Drilling Contractor Layne

Drilling Fluid N/A

Development Date N/A

Development Technique N/A

Water Removed N/A gals.

Static Depth to Water N/A ft. below TOC

Comments vent was completed above the water table
- no surface casing was installed
- 100 silica sand was used instead of bentonite

Depths From Ground Surface Unless Otherwise Noted

Prepared By Peter R. Berglund

RMA Well Completion Record

Well Number _____

Project EDSVEP

Borehole Number EV-4

Date _____

Surveyed Location 178 056.225 N
2184 388.305 E

Surveyed Elevation GS 5265.70 ft.
TOC 5266.80 ft.

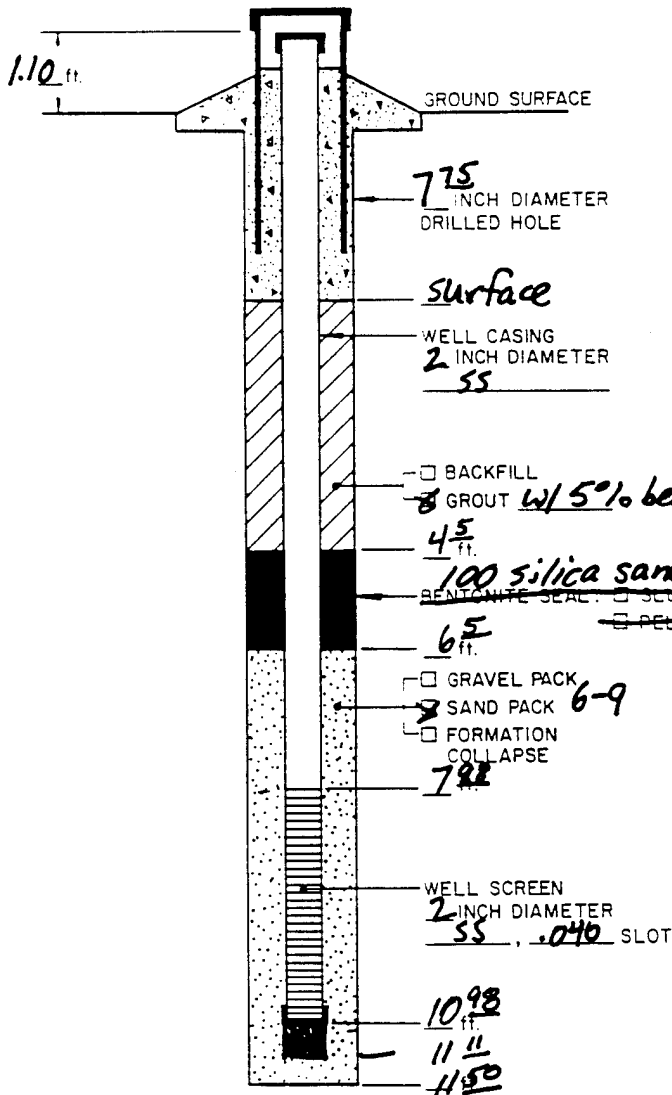

Installation Date 920416

Drilling Method Hollow Stem Auger

Drilling Contractor Layne

Drilling Fluid N/A

Development Date N/A

Development Technique N/A

Water Removed N/A gals.

Static Depth to Water N/A ft. below TOC

Comments Vent was completed

above the water table

- no surface casing was installed

- 100 silica sand was used

instead of bentonite

Depths From Ground Surface
Unless Otherwise Noted

Prepared By Peter Berglund

RMA Well Completion Record

Well Number _____

Project EDSVEP

Borehole Number IV-1

Date _____

Surveyed Location 178062.503 N
2184394.710 E

Surveyed Elevation GS 5265.72 ft.
TOC 5267.45 ft.

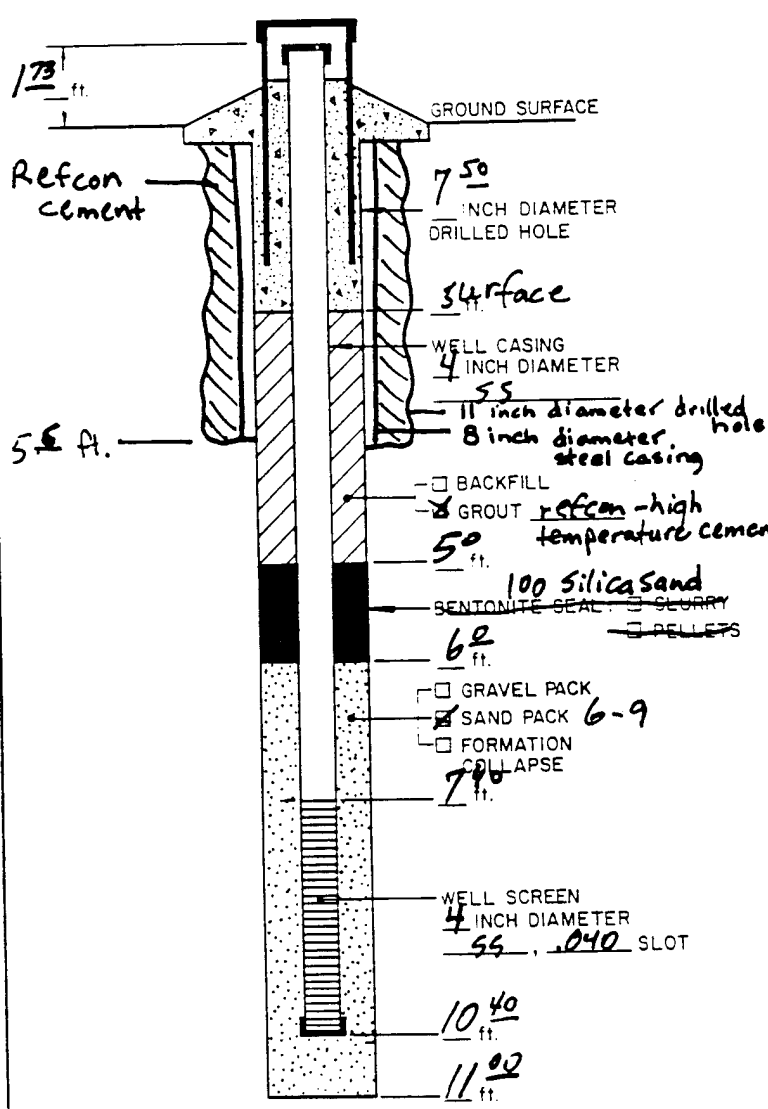

Installation Date 920417
Drilling Method Hollow Stem Auger
Drilling Contractor Layne
Drilling Fluid N/A
Development Date N/A
Development Technique N/A

Water Removed N/A gals.
Static Depth to Water N/A ft. below TOC

Comments vent was completed above the water table
- no surface casing was installed
- 100 silica sand was used instead of bentonite

Depths From Ground Surface Unless Otherwise Noted

Prepared By Peter Berglund

Monitoring Probe Completion Record

Well Point Number MP-X-3

Project EDSVEP

Borehole Number _____

Date 920920

Surveyed _____

Surveyed _____

Location _____ N
_____ E

Elevation GS _____ ft.
TOC _____ ft.

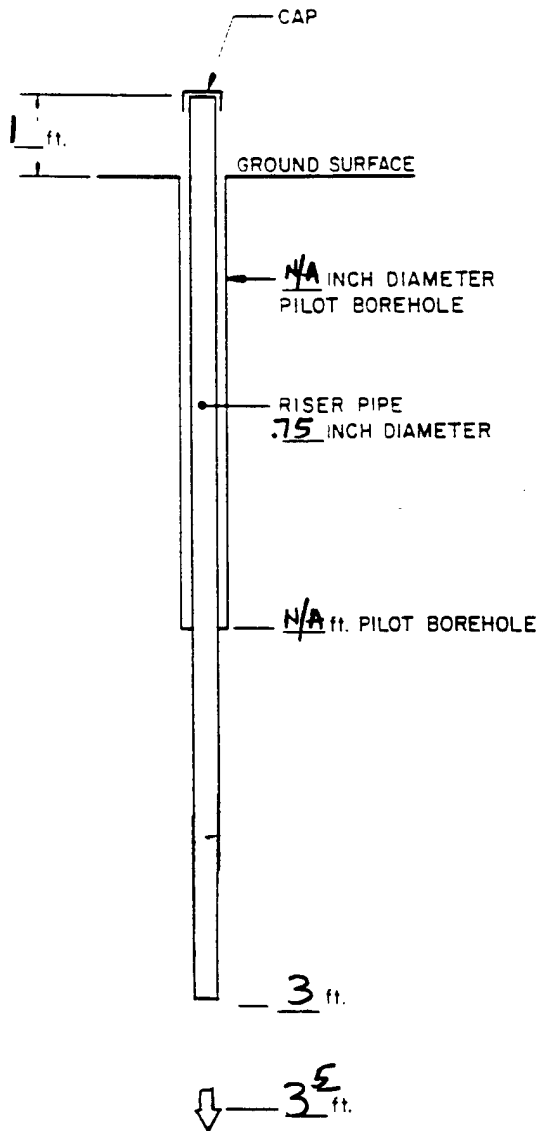

Installation Date 920420

Drilling Method 140# jar hammer

Drilling Contractor Layne

Comments _____

Depths From Ground Surface
Unless Otherwise Noted

Prepared By Peter R. Berghoff

Monitoring Probe Completion Record

Well Point Number MP-X-6

Project EDSVEP

Eorehole Number _____

Date 920915

Surveyed _____

Surveyed _____

Location _____ N

Elevation GS _____ ft.

_____ E

TOC _____ ft.

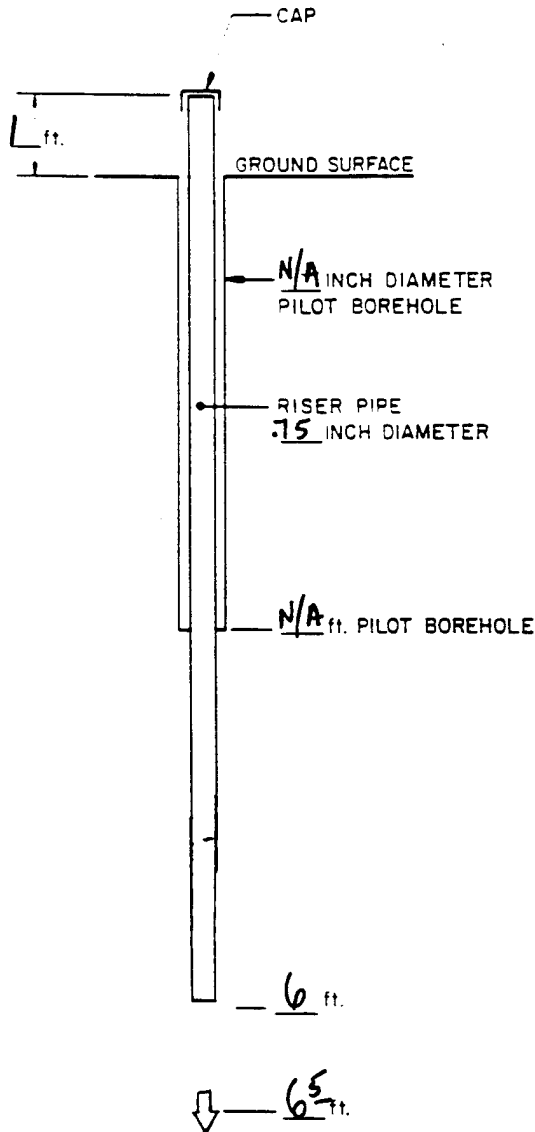

Installation Date 920420

Drilling Method 110# jar hammer

Drilling Contractor _____

Comments _____

Depths From Ground Surface
Unless Otherwise Noted

Prepared By Peter R. Burghard

Monitoring Probe Completion Record

Well Point Number MP-X-9

Project EDSVEP

Borehole Number _____

Date 920915

Surveyed _____

Surveyed _____

Location _____ N

Elevation GS _____ ft.

_____ E

TOC _____ ft.

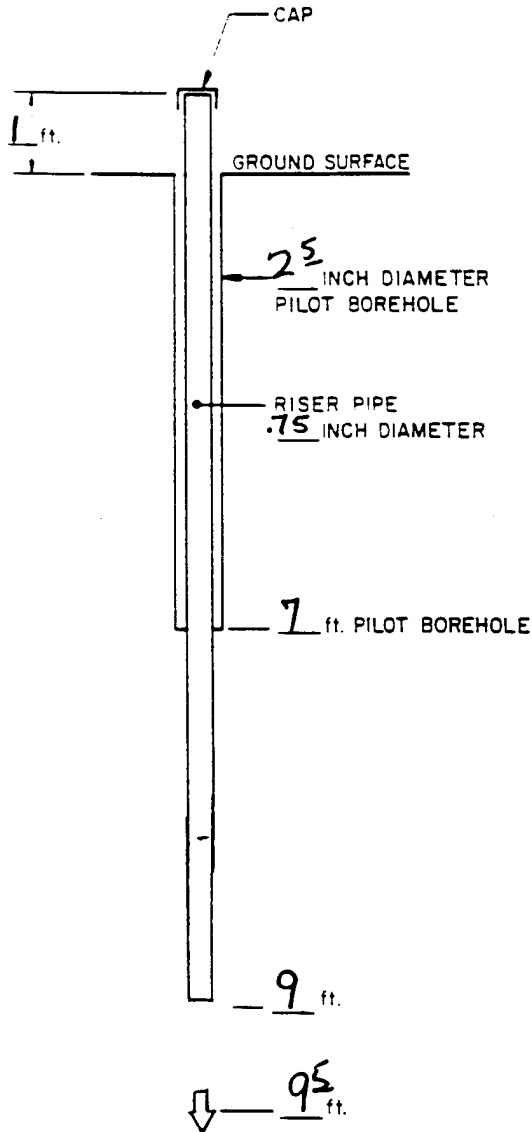

Installation Date 920420

Drilling Method Solid Stem Auger

Drilling Contractor Layne

Comments Solid Stem Augers were used to drill the pilot hole - 140# jar hammer was used to drive probe to depth

Depths From Ground Surface
Unless Otherwise Noted

Prepared By Peter R Berglund

Monitoring Probe Completion Record

Well Point Number MP-X-11

Project EOSVEP

Borehole Number _____

Date 920915

Surveyed Location _____ N
_____ E

Surveyed Elevation GS _____ ft.
TOC _____ ft.

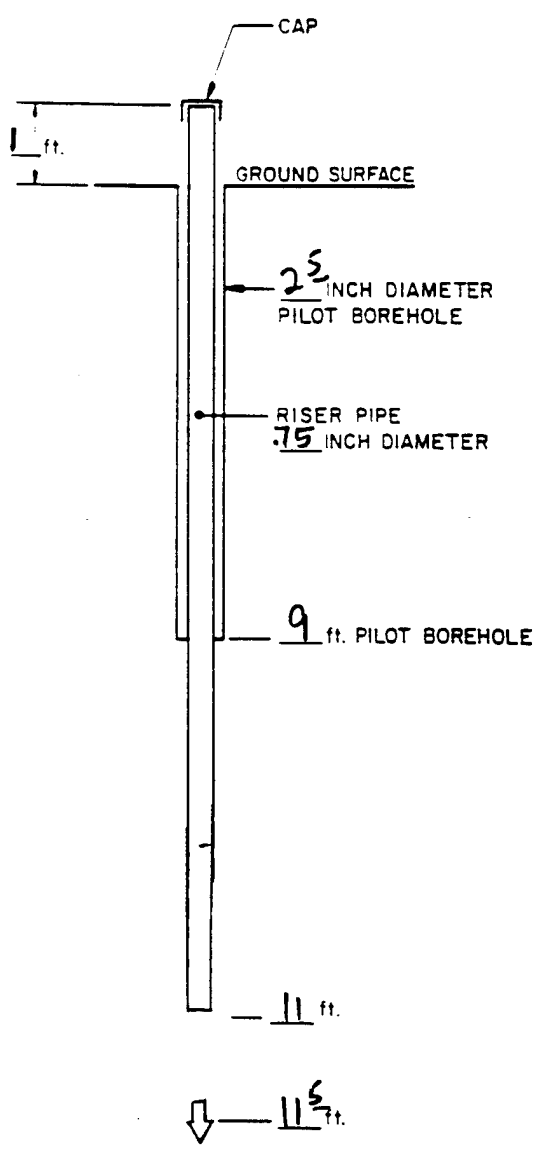

Installation Date 920420
Drilling Method Solid Stem Auger
Drilling Contractor Layne

Comments Solid stem Augers were used to drill the pilot hole - 140# jar hammer was used to drive probe to depth

Depths From Ground Surface Unless Otherwise Noted

Prepared By Peter R. Berglund

APPENDIX B

04/06/95

WOODWARD-CLYDE DLY MAX & MIN TEMP AND PRESS. TOTAL DLY PRECIP

DATE	MAX AT	MIN AT	MAX PR	MIN PR	DYTL	PC
6 1	56.49	42.64	24.86	24.8		.38
6 2	67.74	43.05	24.81	24.67		0
6 3	75	48.83	24.76	24.6		0
6 4	73.3	49.09	24.81	24.57		0
6 5	66.76	49.5	24.74	24.5		.04
6 6	70.3	46.8	24.74	24.62		0
6 7	69.86	49.55	24.77	24.66		.07
6 8	65.9	48.88	24.81	24.74		.74
6 9	65.91	49.01	24.79	24.73		0
6 10	73.8	48.31	24.8	24.75		0
6 11	74.3	53.55	24.85	24.8		0
6 12	76	53.63	24.82	24.66		0
6 13	80.8	55.25	24.65	24.53		.22
6 14	75.7	51.79	24.63	24.43		0
6 15	73.7	53.73	24.58	24.46		0
6 16	998	54.23	24.6	24.44		0
6 17	998	56.08	24.93	24.6		.04
6 18	81.1	52.43	24.9	24.77		998
6 19	70.7	55.9	24.87	24.78		.27
6 20	74.7	52.95	24.91	24.78		.03
6 21	76	56.65	24.91	24.84		0
6 22	81.8	56.18	24.93	24.81		0
6 23	82	60.78	24.87	24.72		0
6 24	85	61.33	24.79	24.67		.02
6 25	67.4	56	24.85	24.77		.57
6 26	71.1	53.33	24.81	24.72		.01
6 27	73.7	56.95	24.77	24.74		0
6 28	77.9	58.36	24.79	24.74		0
6 29	83	55.97	24.79	24.58		0
6 30	89.3	63.08	24.58	24.43		0

WOODWARD-CLYDE DLY MAX & MIN TEMP AND PRESS: TOTAL DLY PRECIP

DATE	MAX AT	MIN AT	MAX PR	MIN PR	DYTL	PC
7 1	66.24	55.73	24.65	24.55		.15
7 2	64.65	48.76	24.91	24.67		.27
7 3	80.6	52.09	24.9	24.76		0
7 4	90.2	58.77	24.8	24.66		0
7 5	88.5	64.2	24.8	24.71		0
7 6	95.1	63.76	24.75	24.66		0
7 7	81.6	64.18	24.87	24.72		0
7 8	76.3	63.22	24.92	24.86		0
7 9	83.7	61.5	24.9	24.75		0
7 10	82.4	57.69	24.91	24.72		.09
7 11	84.1	58.93	24.73	24.56		.05
7 12	70.9	56.61	24.72	24.67		.2
7 13	76.4	56.25	24.78	24.7		0
7 14	84.3	58.95	24.8	24.71		0
7 15	79.7	55.44	24.82	24.73		.12
7 16	66.54	50.97	24.94	24.81		.22
7 17	74.3	52.98	24.97	24.91		.2
7 18	82	59.63	24.94	24.84		0
7 19	78.6	57.06	24.96	24.85		.01
7 20	75.5	56.79	24.96	24.84		.01
7 21	83.4	55.48	24.86	24.65		0
7 22	79.4	57.43	24.86	24.78		.01
7 23	83.9	57.47	24.83	24.76		0
7 24	85	57.4	24.9	24.8		.01
7 25	74.1	59.66	25.01	24.87		.06
7 26	78.9	57.67	24.99	24.9		.07
7 27	85.8	57.93	24.95	24.87		0
7 28	87.3	62.24	24.89	24.8		0
7 29	83.1	60.28	24.91	24.72		0
7 30	77.9	55.96	24.95	24.86		0
7 31	84.8	54.71	24.95	24.86		0

WOODWARD-CLYDE DLY MAX & MIN TEMP AND PRESS. TOTAL DLY PRECIP

DATE	MAX AT	MIN AT	MAX PR	MIN PR	DYTL PC
8 1	83.6	56.11	24.98	24.91	0
8 2	85.8	59.87	24.98	24.87	0
8 3	77.7	58.77	24.93	24.84	.06
8 4	86.5	55.64	24.86	24.77	0
8 5	81.2	56.09	24.91	24.82	0
8 6	81.1	64.52	24.84	24.76	.01
8 7	88.1	59.12	24.82	24.78	0
8 8	86.8	66.63	24.88	24.82	.04
8 9	91.5	65	24.94	24.85	0
8 10	78.8	58.87	25.07	24.93	0
8 11	74.4	59.46	25.01	24.95	.17
8 12	62.42	56.58	25.09	24.99	.04
8 13	78.6	51.86	24.99	24.91	0
8 14	79.2	54.09	25.06	24.94	0
8 15	86.7	58.57	24.98	24.87	0
8 16	78.1	59.27	24.9	24.84	.02
8 17	69.14	53.17	25	24.73	.18
8 18	75.6	54.72	25.01	24.92	.01
8 19	84.4	55.9	24.95	24.86	0
8 20	89.3	60.86	24.88	24.78	0
8 21	84.6	57.42	24.89	24.76	0
8 22	87.8	61.83	24.79	24.59	.08
8 23	75.4	56.26	24.81	24.69	.16
8 24	55.53	49.75	24.96	24.81	2.55
8 25	65.92	49.18	24.99	24.9	0
8 26	65.33	49.1	25.03	24.94	0
8 27	77.1	49.03	25.03	24.88	0
8 28	83.2	54.37	24.92	24.78	0
8 29	64.63	19.53	24.96	23.47	.01
8 30	69.93	50.83	24.95	24.83	0
8 31	71	52.99	24.84	24.74	0

WOODWARD-CLYDE DLY MAX & MIN TEMP AND PRESS: TOTAL DLY PRECIP

DATE	MAX AT	MIN AT	MAX PR	MIN PR	DYTL	PC
9 1	72.2	51.1	24.79	24.71		0
9 2	77.3	58.69	24.88	24.79		0
9 3	80.4	55.14	24.91	24.81		0
9 4	84.6	60.88	24.79	24.5		0
9 5	74.5	57	24.82	24.72		0
9 6	78.6	50.6	24.87	24.71		0
9 7	67.49	50.36	24.98	24.78		0
9 8	82.8	47.07	24.92	24.61		0
9 9	68.78	50.37	24.89	24.68		0
9 10	73.1	44.97	25.01	24.87		0
9 11	86.5	51.57	24.89	24.76		0
9 12	86.8	62.4	24.79	24.62		0
9 13	83.1	58.54	24.78	24.64		0
9 14	81.6	52.91	24.83	24.68		0
9 15	82.9	60.02	24.77	24.7		.01
9 16	81.2	60.93	24.84	24.77		0
9 17	81.8	47.38	24.99	24.68		0
9 18	67.15	40.1	25	24.77		0
9 19	74	52.85	24.77	24.62		0
9 20	76.9	55.52	24.65	24.56		0
9 21	68.46	53.15	24.97	24.64		.01
9 22	79.7	49.23	24.98	24.86		0
9 23	86.4	56.96	24.89	24.75		0
9 24	85.4	58.34	24.75	24.49		0
9 25	67.02	49.44	24.86	24.48		0
9 26	68.81	39.74	24.97	24.87		0
9 27	76.3	48.15	25.1	24.86		0
9 28	70.3	40.51	25.12	24.98		0
9 29	78.8	48.02	25.04	24.97		0
9 30	81.1	49.62	25.04	24.95		0

APPENDIX B

07/05/95

FIGURES

07/05/95

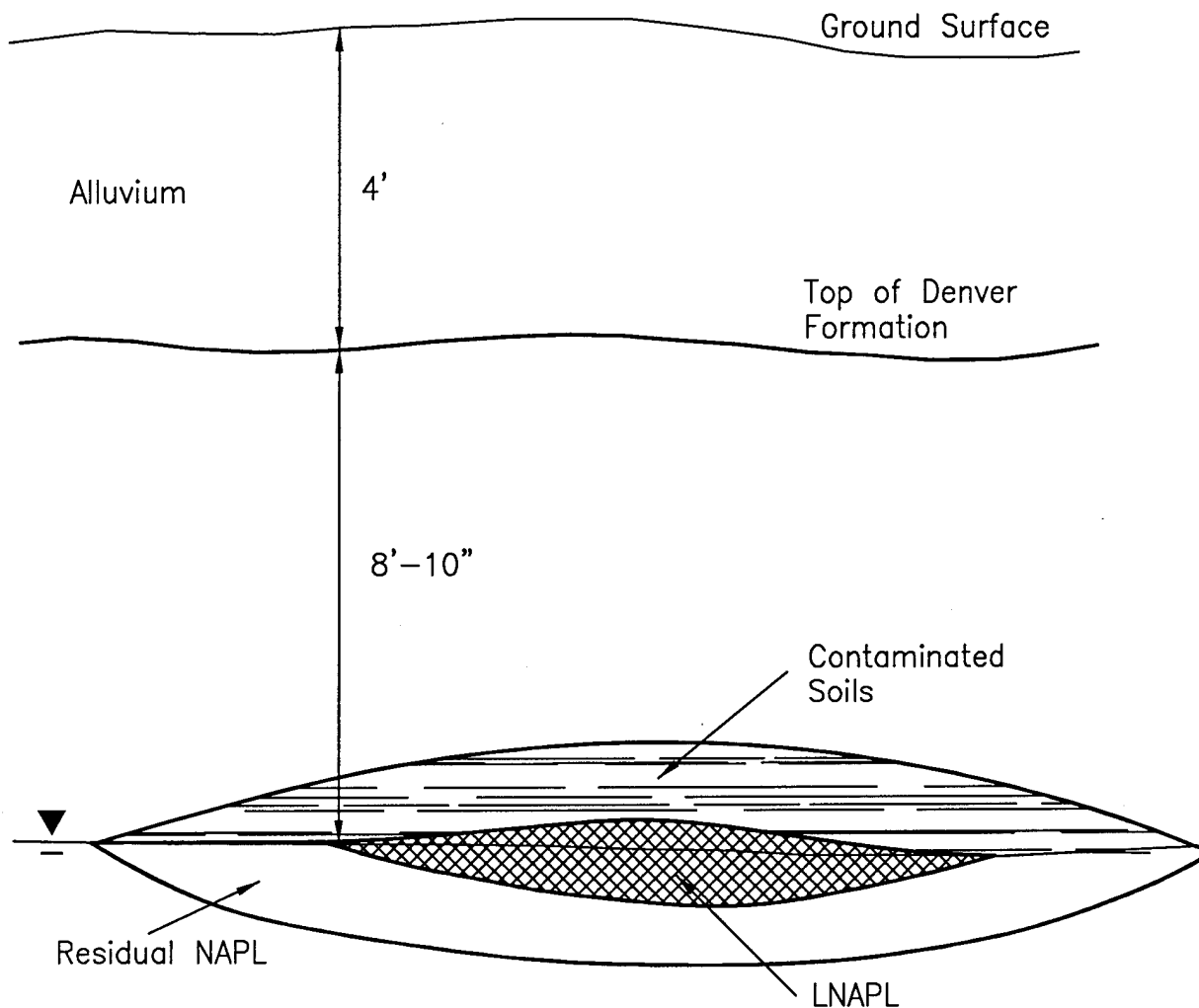

MORRISON KNUDSEN CORPORATION

MORRISON KNUDSEN CORPORATION

Figure 1

Schematic of Current Site Conditions

 **MORRISON KNUDSEN CORPORATION**
ENVIRONMENTAL SERVICES DIVISION

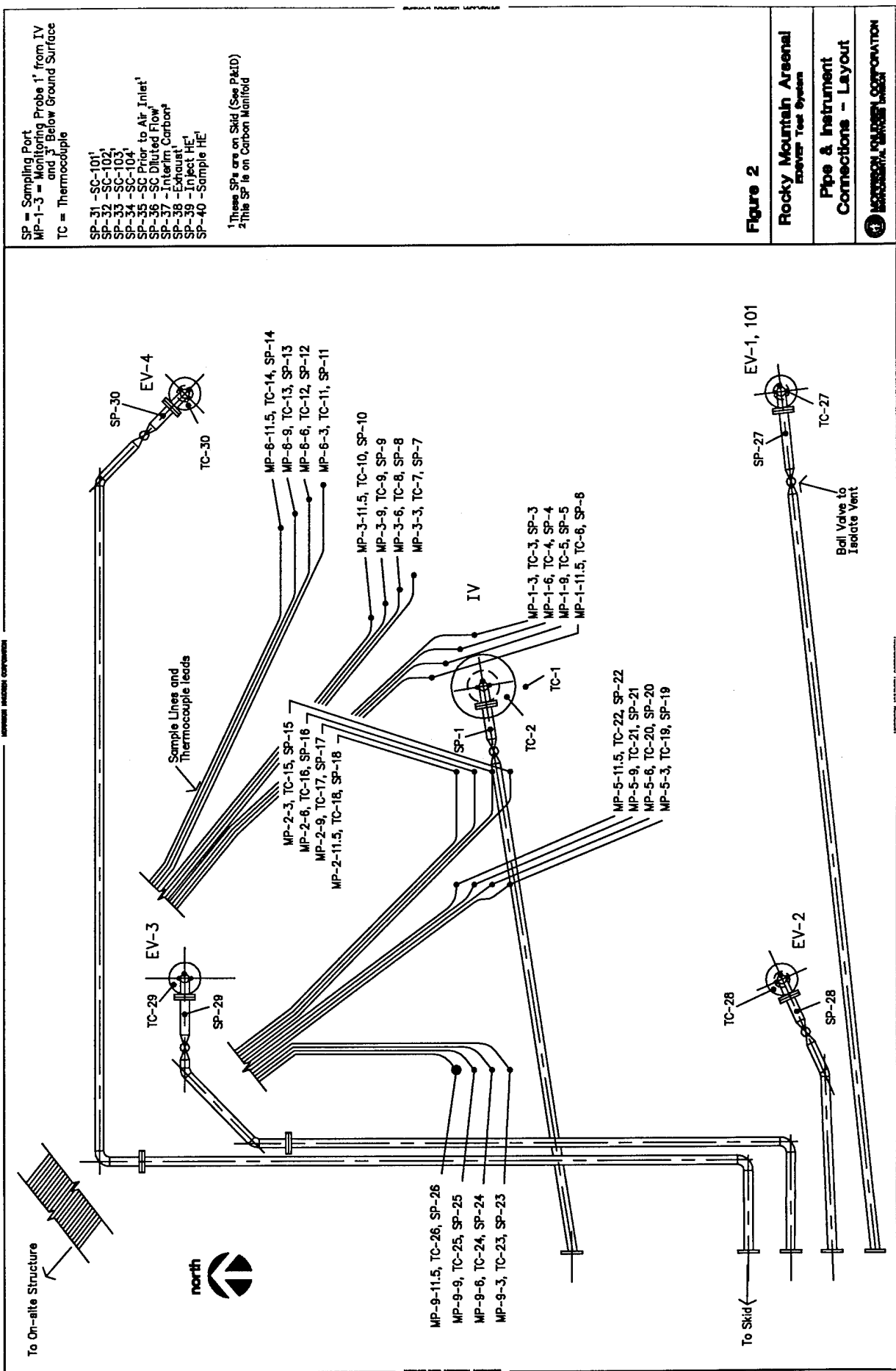

SP = Sampling Port
 MP-1-3 = Monitoring Probe 1' from IV
 and 3' Below Ground Surface
 TC = Thermocouple

SP-31 - SC-101¹
 SP-32 - SC-102¹
 SP-33 - SC-103¹
 SP-34 - SC-104¹
 SP-35 - SC Prior to Air Inlet¹
 SP-36 - SC Diluted Flow¹
 SP-37 - Interim Carbon¹
 SP-38 - Exhaust¹
 SP-39 - Inject HE¹
 SP-40 - Sample HE¹

¹These SPs are on Skid (See P&ID)
²This SP is on Carbon Manifold

Figure 2

Rocky Mountain Arsenal
 Exhaust Test System

Pipe & Instrument
 Connections - Layout

© ROCKWELL INTERNATIONAL CORPORATION

NOTES

1. ALL 2" PIPE OR FLOW METERING RUNS SHALL BE INSTALLED WITH A DRAIN VALVE AND A DRAIN LINE TO THE WELLS. DRAIN VALVES SHALL BE LOCATED AT LEAST 20' DOWNSTREAM AND AT LEAST 5' UPSTREAM OF DISTURBANCES.
2. ALL SAMPLE CONNECTIONS SHALL BE 1/4" STAINLESS STEEL VALVES NIPROD-35-4411 OR EQUIVALENT.
3. ALL P.T.'S AND P.T.'S SHALL BE INSTALLED WITH ROOT VALVES (NOT SHOWN).
4. STACK SHALL EXTEND TO 30 FEET ABOVE GRADE AND MAY BE BUILT IN TWO SECTIONS.
5. DRAIN PUMP T-201 SHALL BE SIZED FOR ONE (1) MINUTE OF FLOW AT THE DESIGN FLOW RATE.
6. PUMP T-201 SHALL BE SIZED FOR ONE (1) MINUTE OF FLOW AT THE DESIGN FLOW RATE.
7. DESIGN AMBIENT TEMP. AND PRESS. AT SITE ARE 70° F AND 12 PSIA, RESPECTIVELY.
8. MAX. SUMMER DAYTIME TEMP. OF 90° F SHOULD BE USED TO SIZE AIR COOLERS.

LEGEND

- PANEL MOUNTED INSTRUMENT
- LOCALLY MOUNTED INSTRUMENT
- CARBON STEEL PIPE
- STAINLESS STEEL PIPE
- HIGH PRESSURE SWITCH
- FLOW ELEMENT (OPTIC TYPE)
- FLOW INDICATOR (ROTOMETER)
- HIGH TEMPERATURE SWITCH
- HAND SWITCH
- LEVEL GAUGE
- SAMPLE CONNECTION
- PRESSURE RELIEF VALVE
- TEMPERATURE INDICATOR
- DIFFERENTIAL PRESSURE INDICATOR
- ELECTRIC MOTOR
- BALL VALVE
- BUTTERFLY VALVE
- INTERLOCK
- FLEX HOSE
- FLANGED CONNECTION
- REDUCER
- IN-LINE STRAINER
- LIMITS OF SKID MOUNTED EQUIPMENT

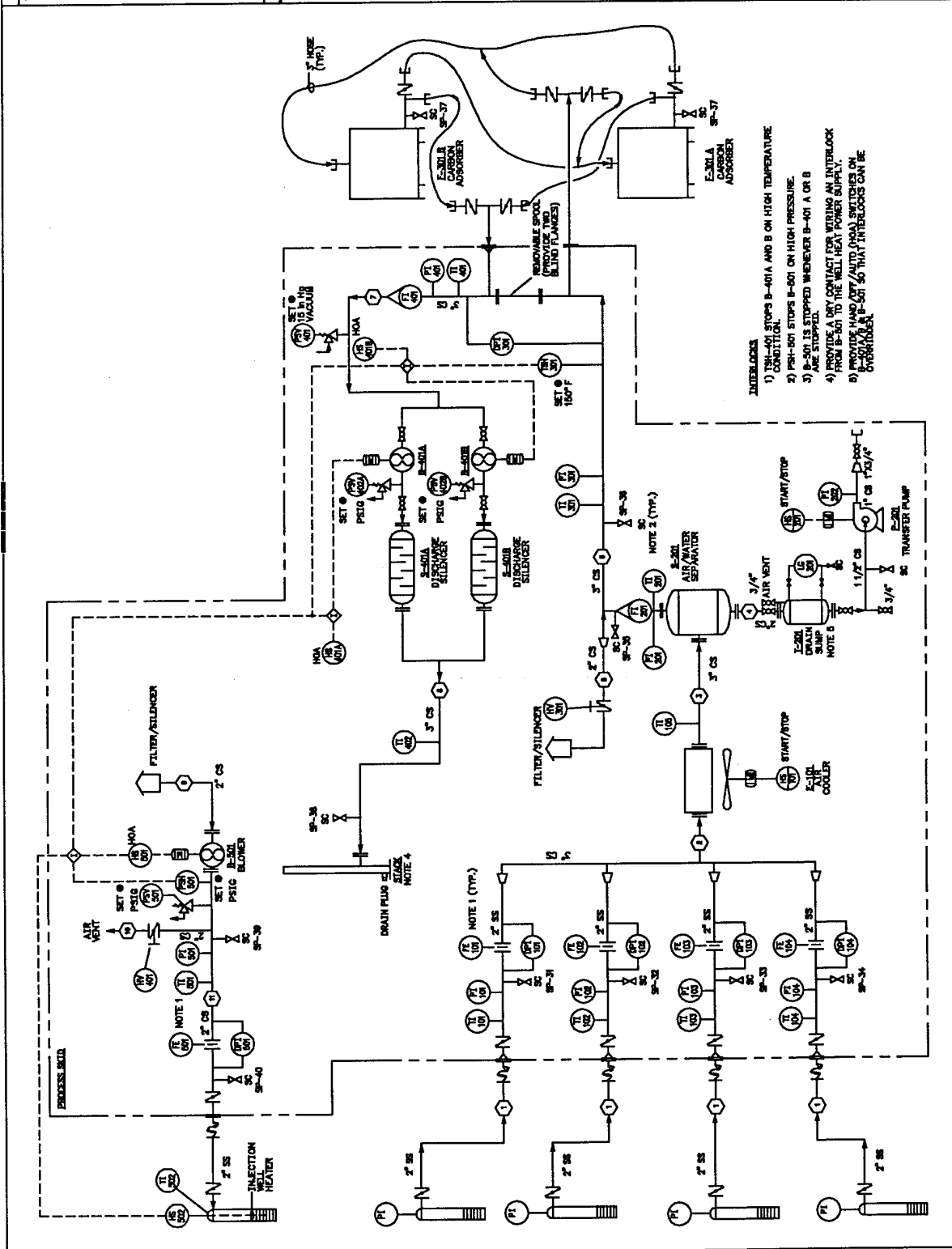

EDSVEP
Treatability Study

PROCESS & INSTRUMENTATION DIAGRAM

MORRISON-KNUDSEN CORPORATION
 ENVIRONMENTAL SERVICES GROUP
 DENVER, COLORADO

Figure 3

Figure 3a

Injection Vent with Heating Element

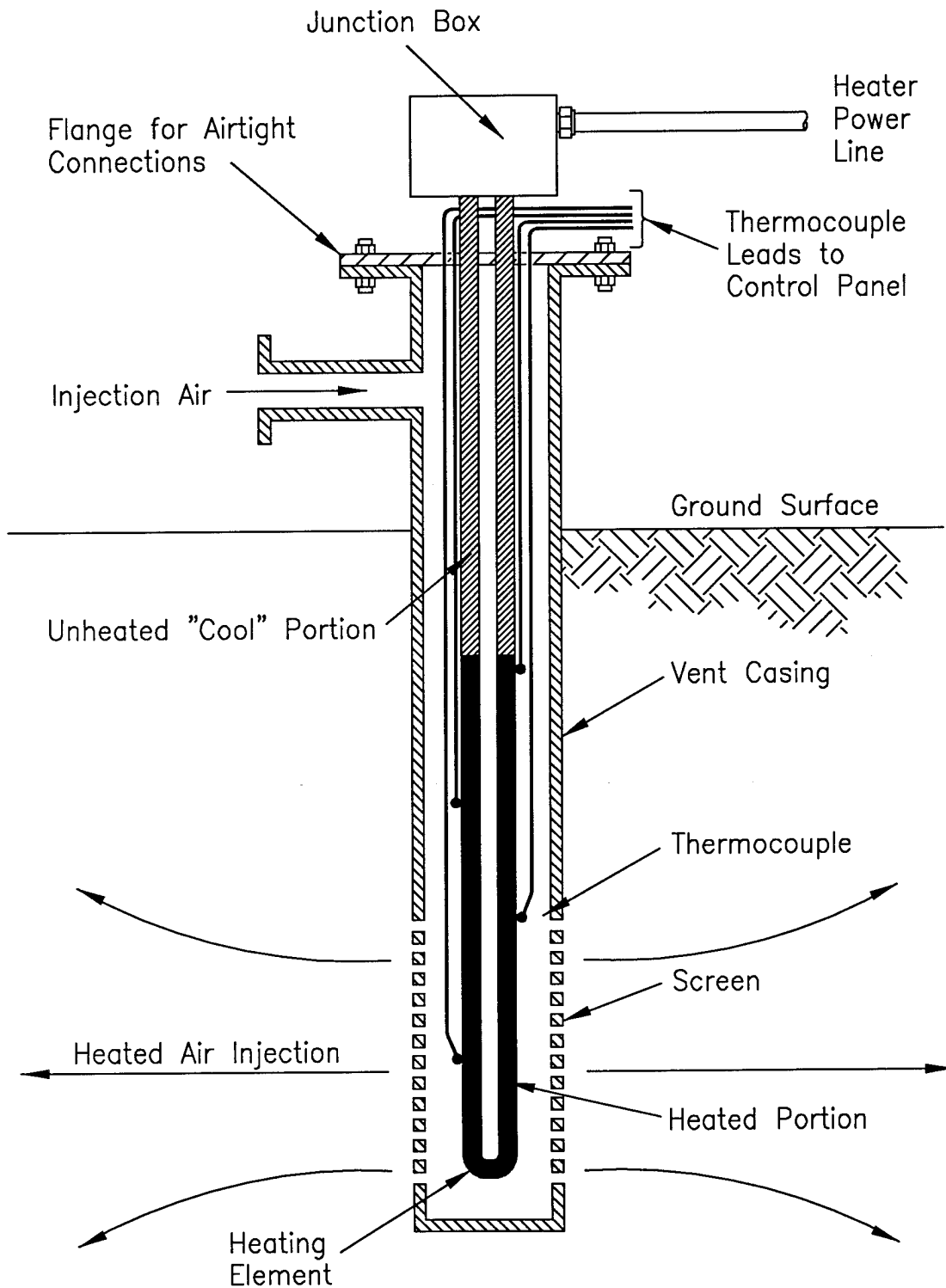

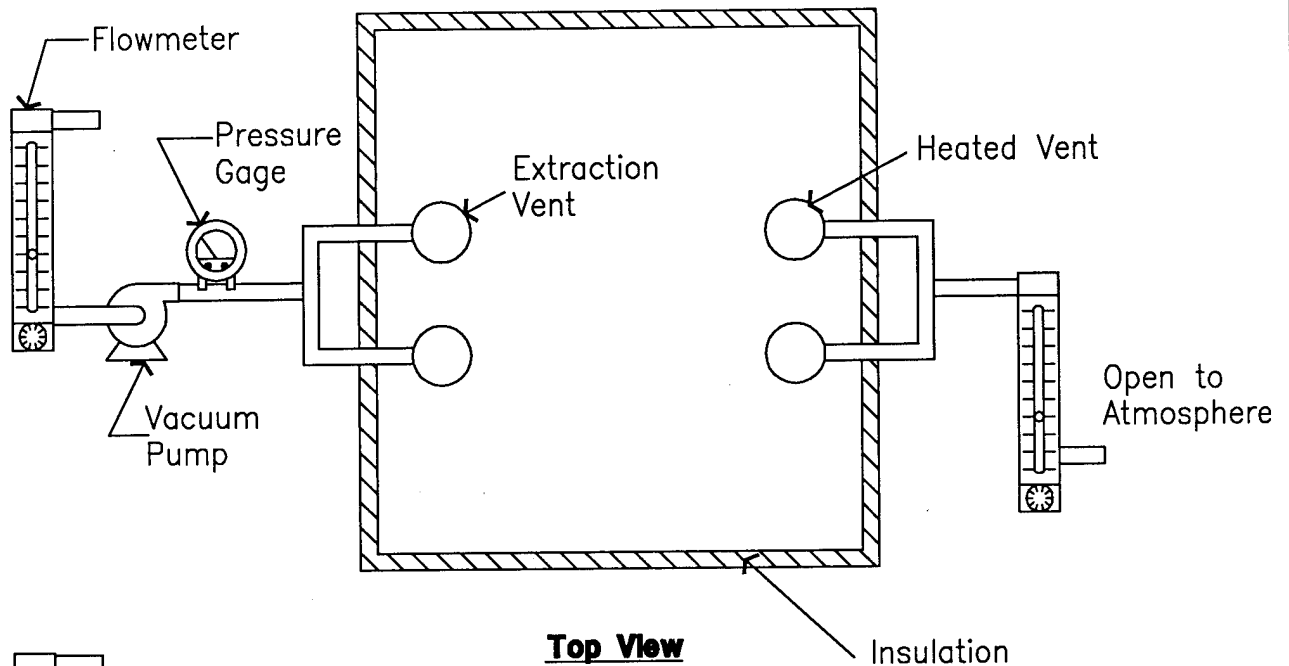

Top View

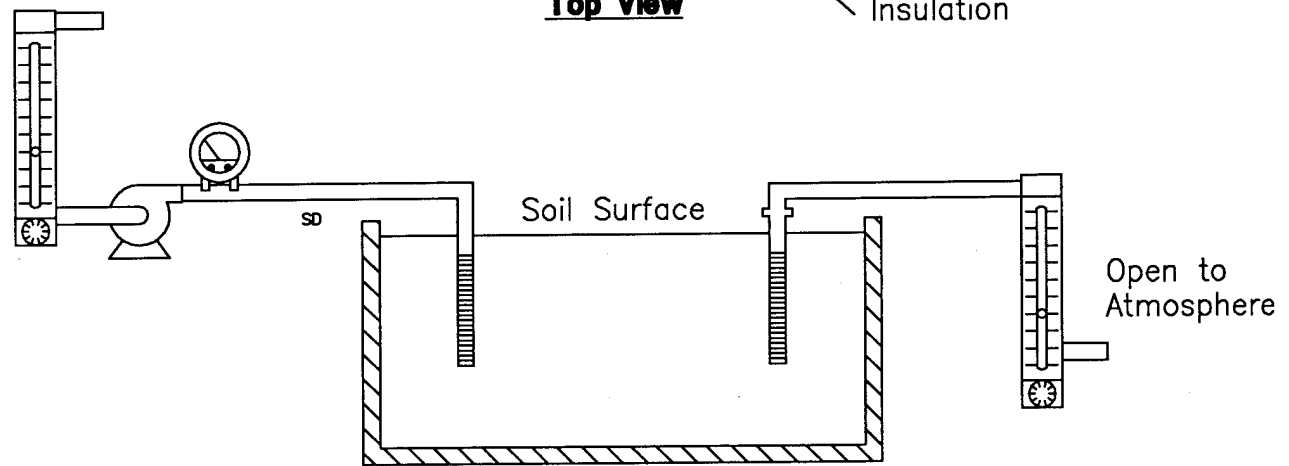

Side View

Bench-Scale System Configuration

- Measurements:
- flowrate (inlet & outlet)
 - central pressure profile
 - central temperature profile
 - moisture production
 - energy input

Figure 4

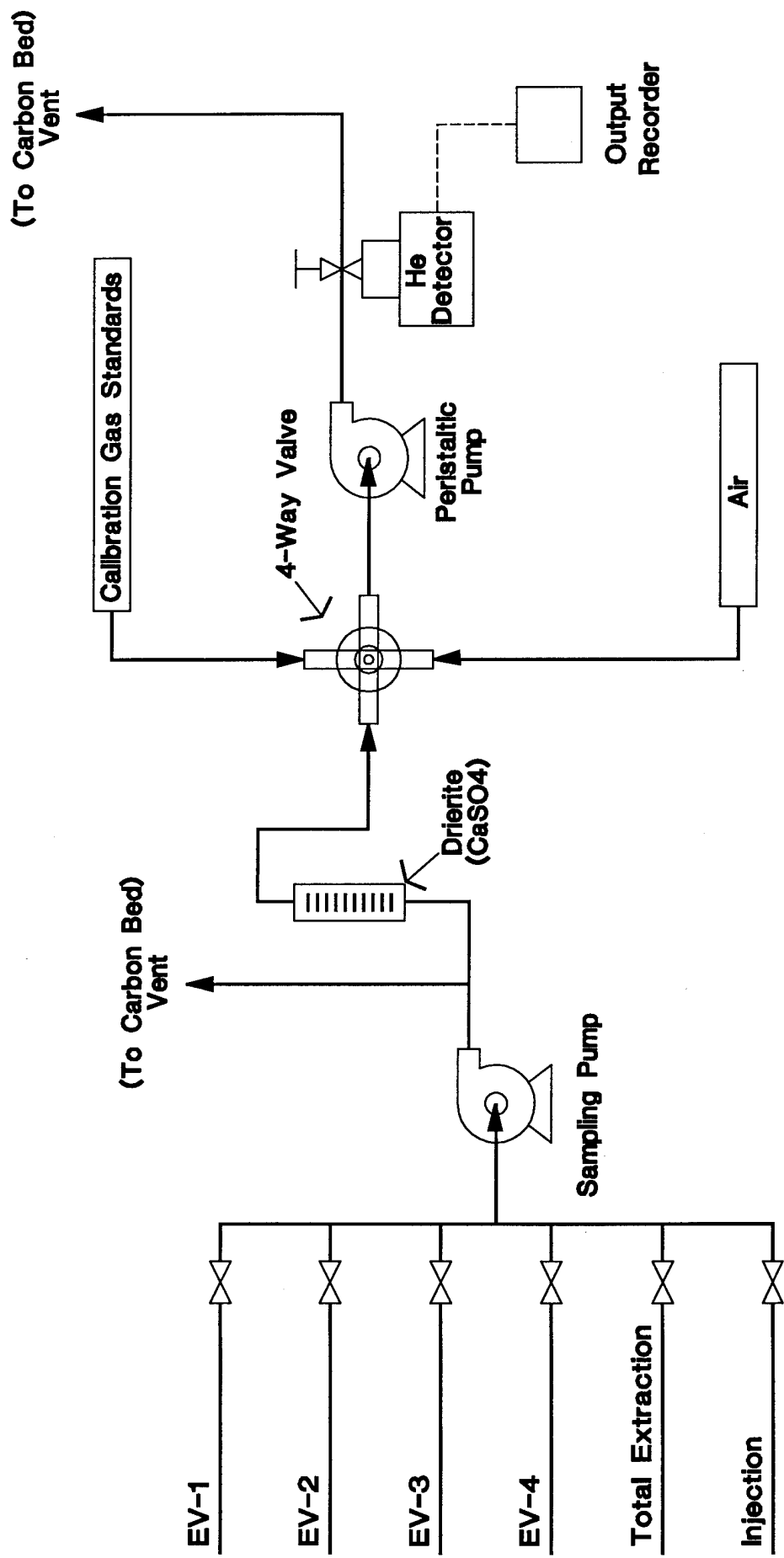

Helium Tracer Test Sampling System

Figure 5

Figure 6
 Normalized Helium Recovery - Pre Heating/Cover

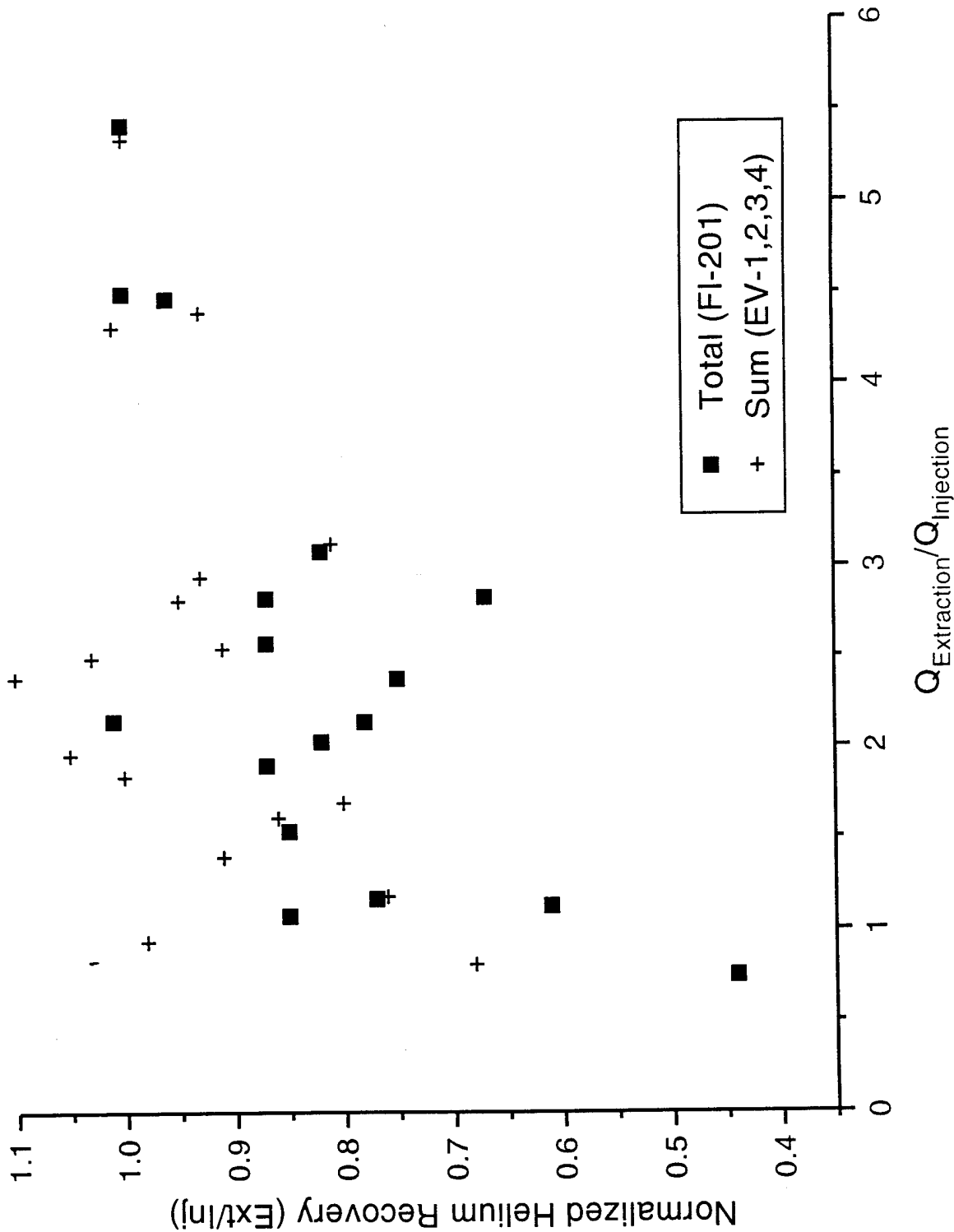

Figure 7
 Pressure Response - Pre Heating/Cover

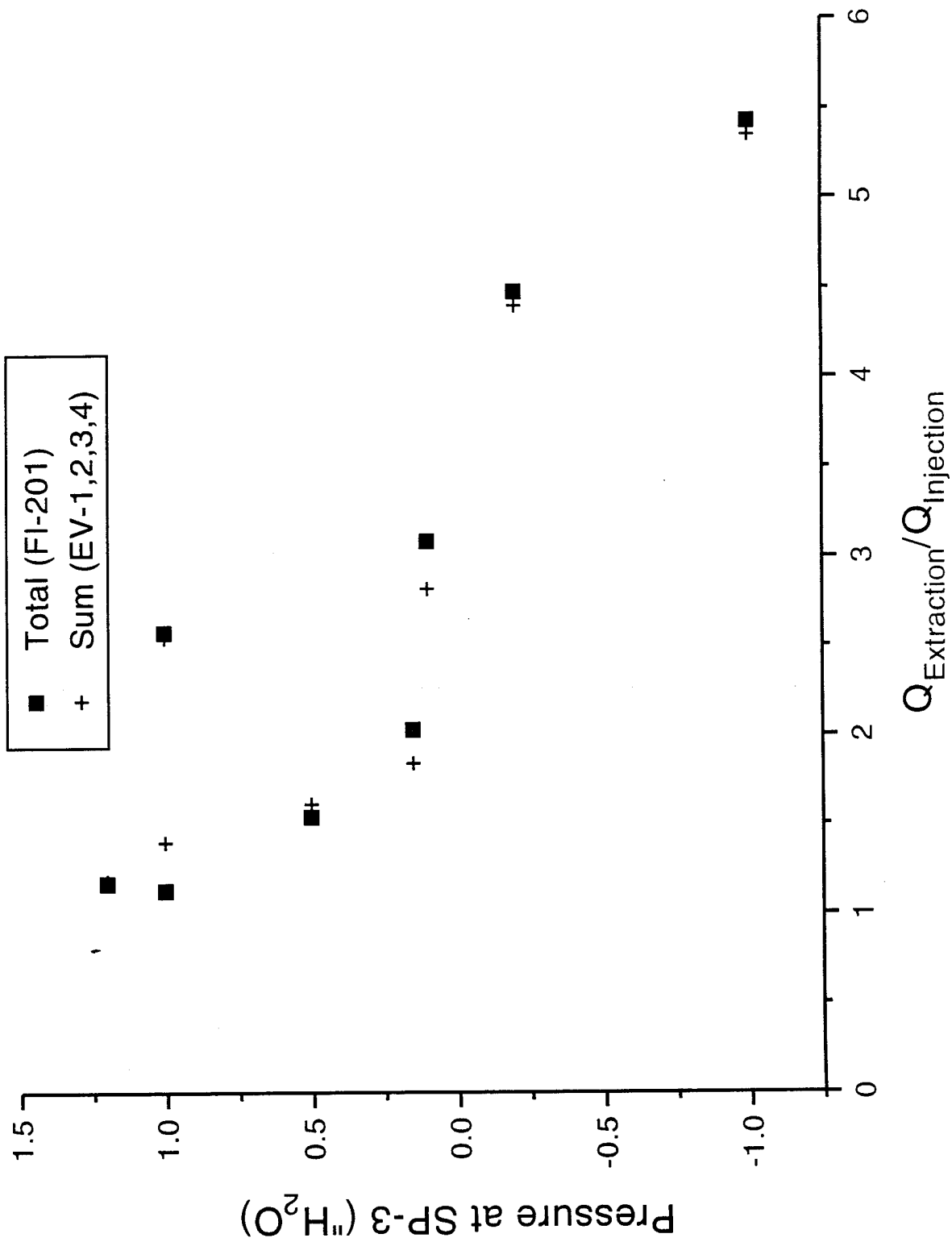

Figure 8

Normalized Helium Recovery - Post Heating/Cover

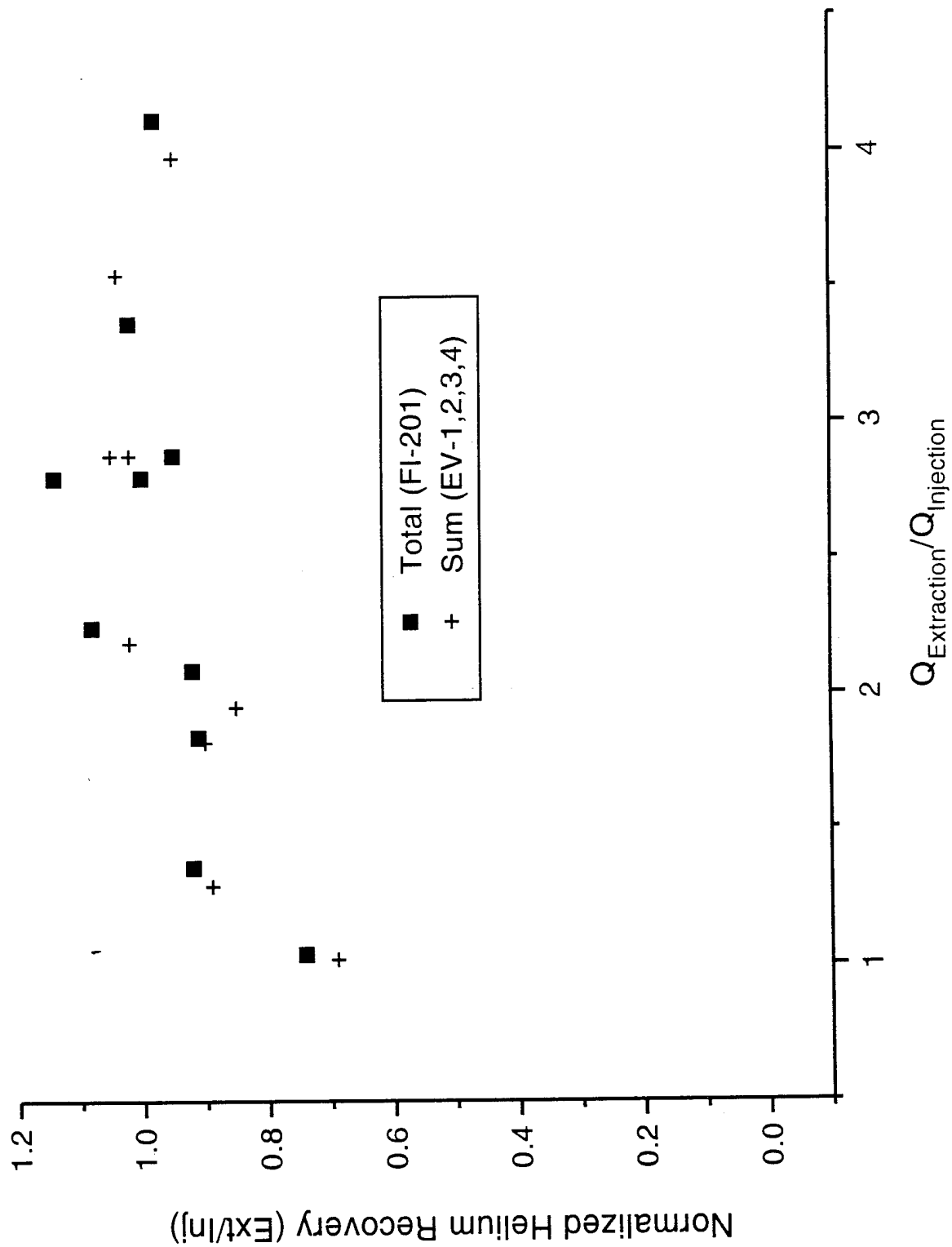

Figure (9)

Pressure Response - Post Heating/Cover

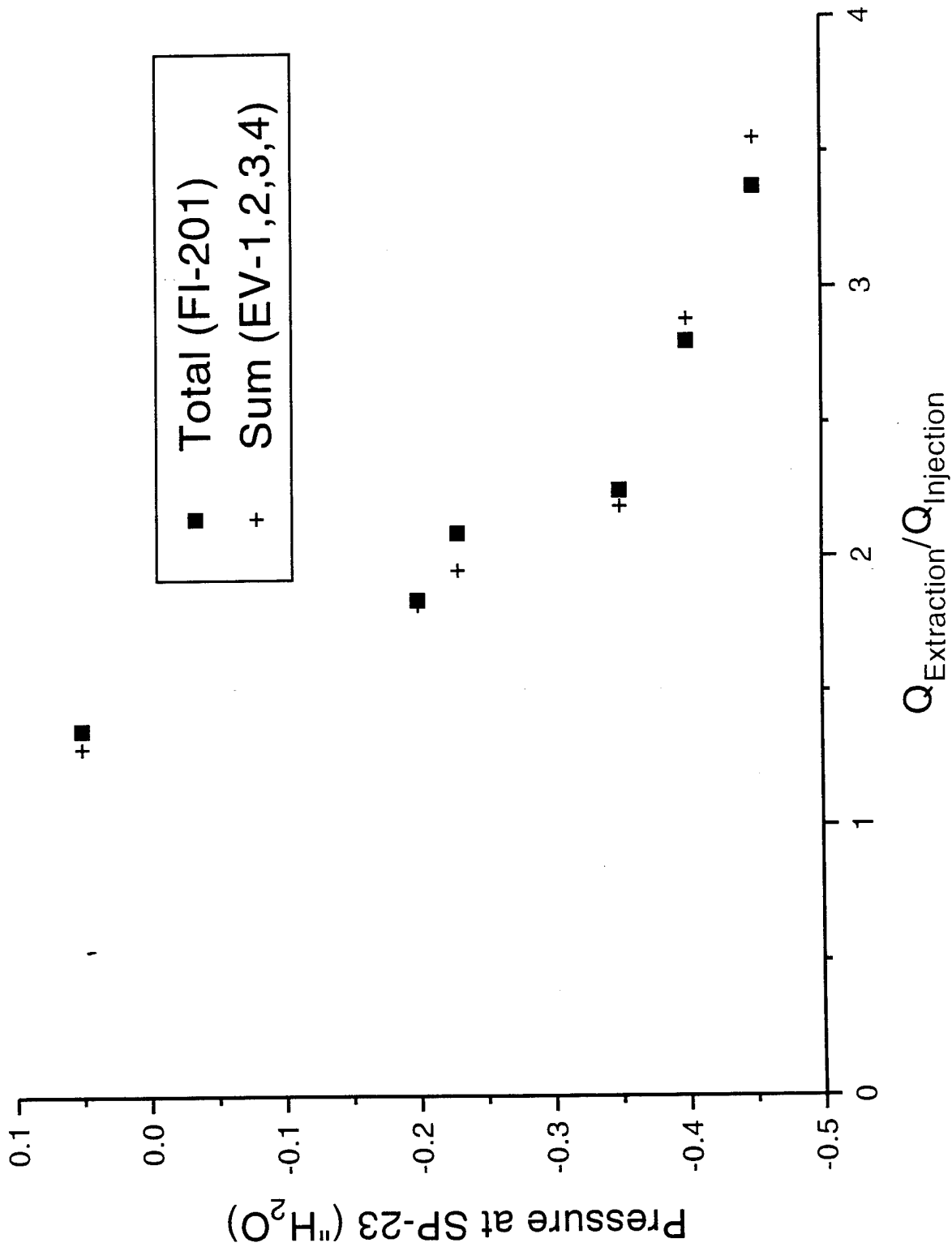

Figure 10. EDSVEP Heating Curves

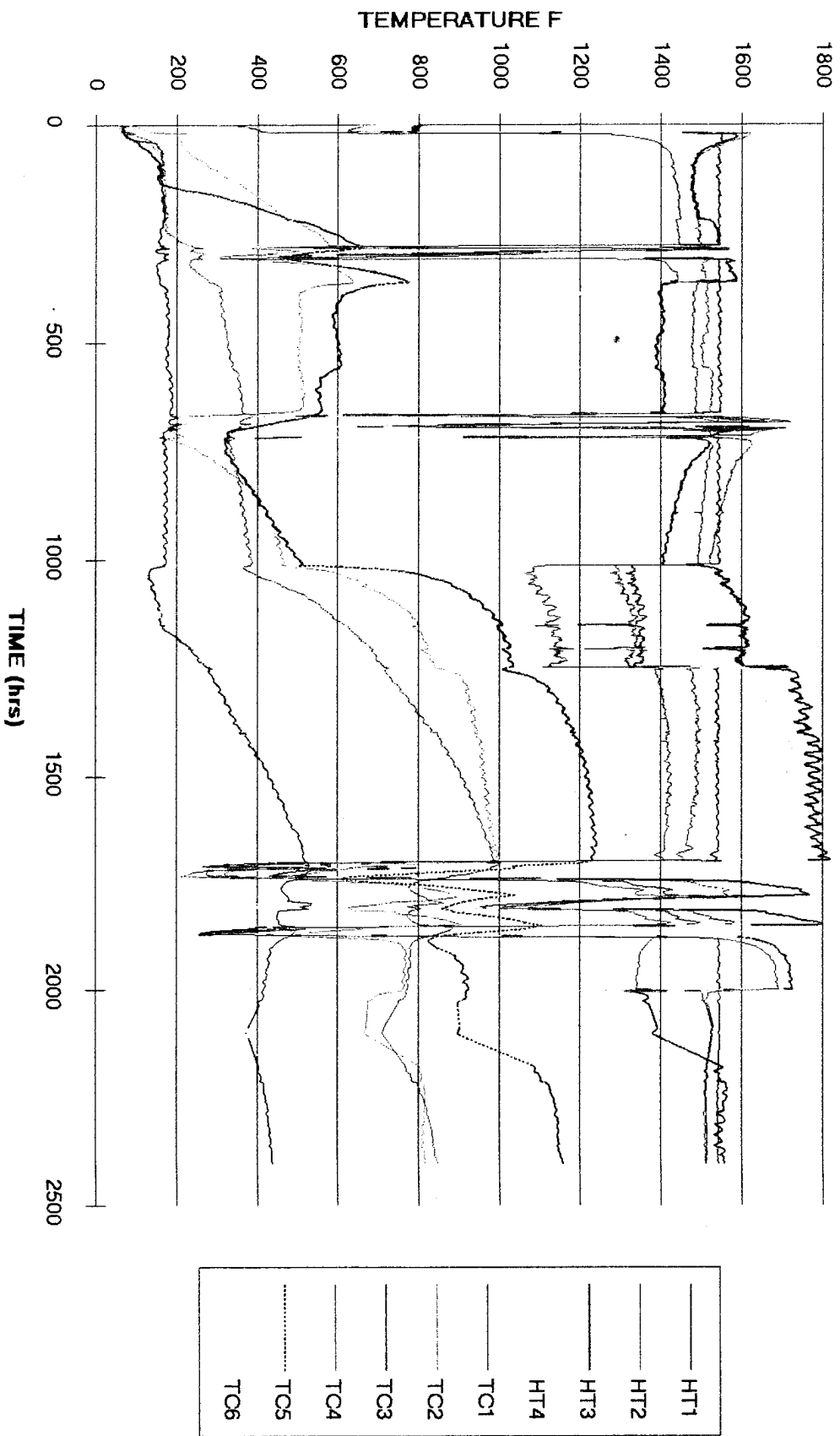

Figure 12. EDSVEP Heating Curves

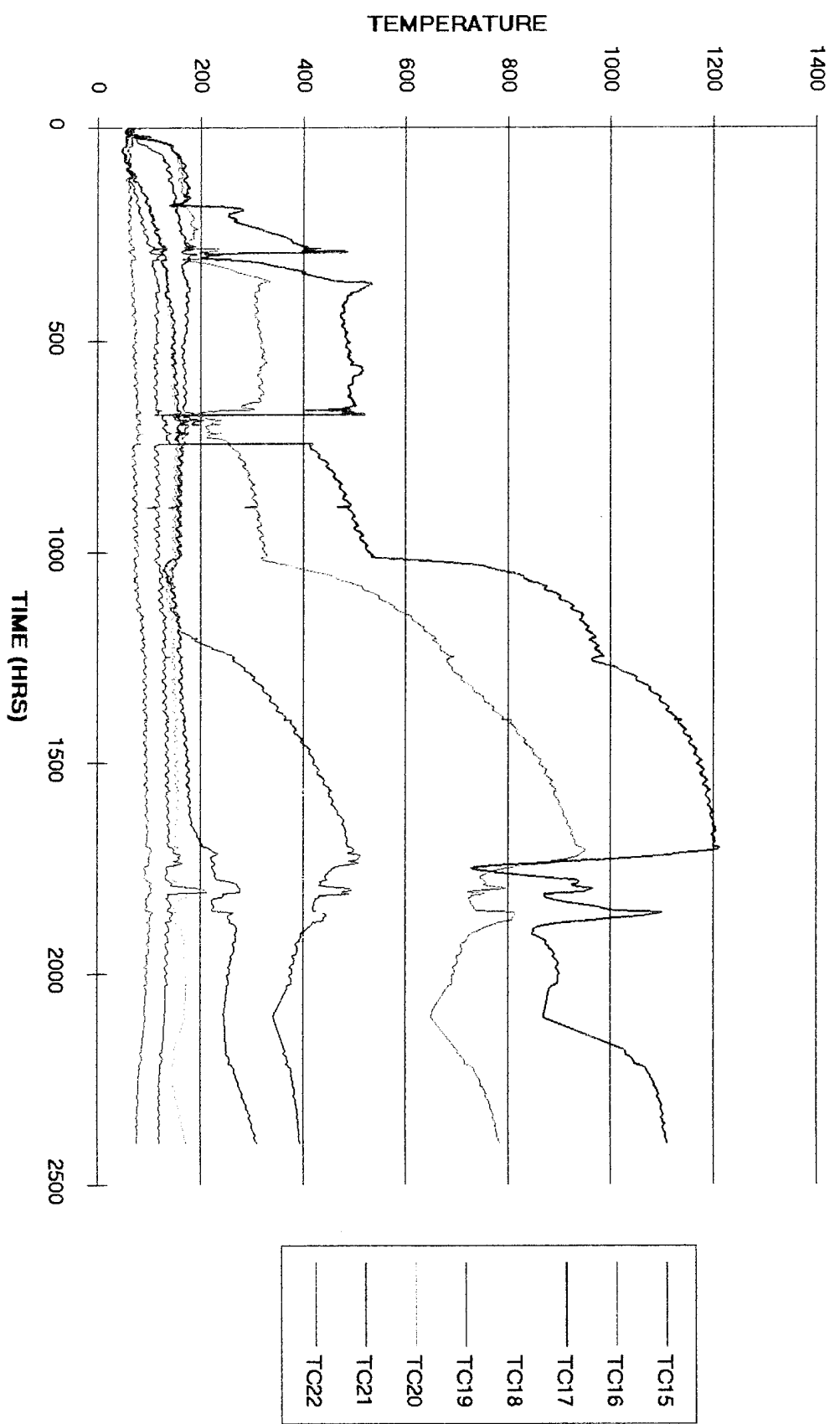

Figure 13
**TEMPERATURE PROFILE
AXIS OF EXTRACTION VENT**

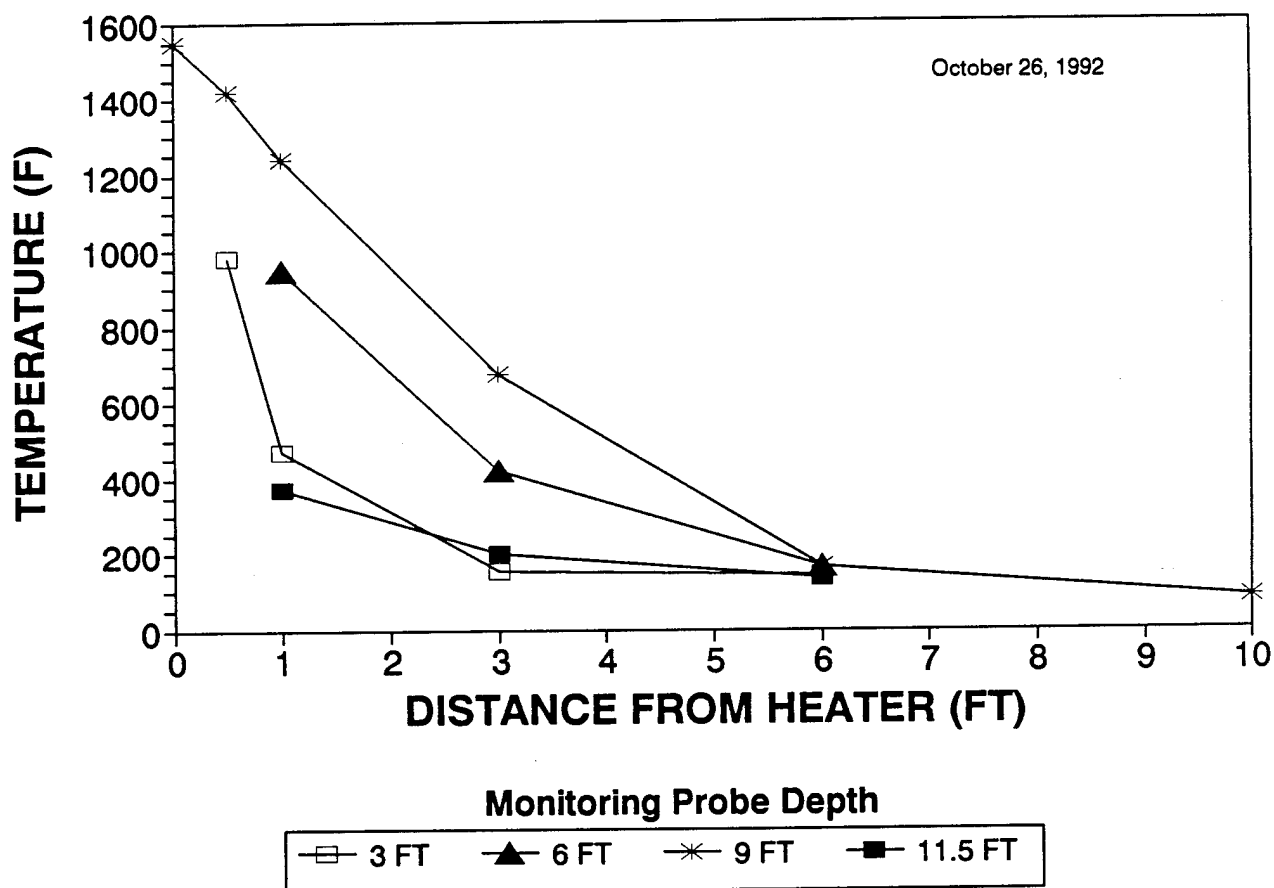

Figure 14
**TEMPERATURE PROFILE
BETWEEN EXTRACTION VENTS**

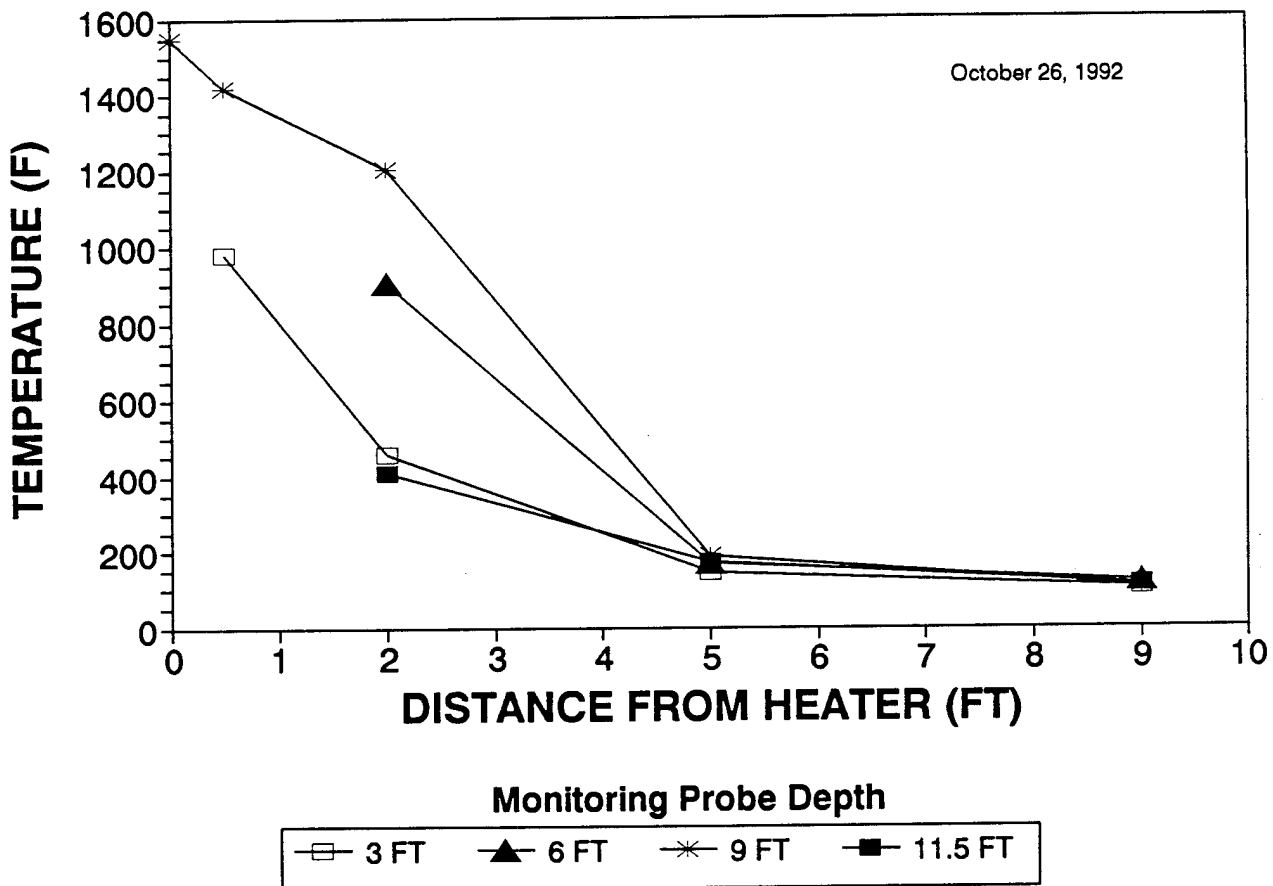

Figure 15
Extracted Vapor Concentrations

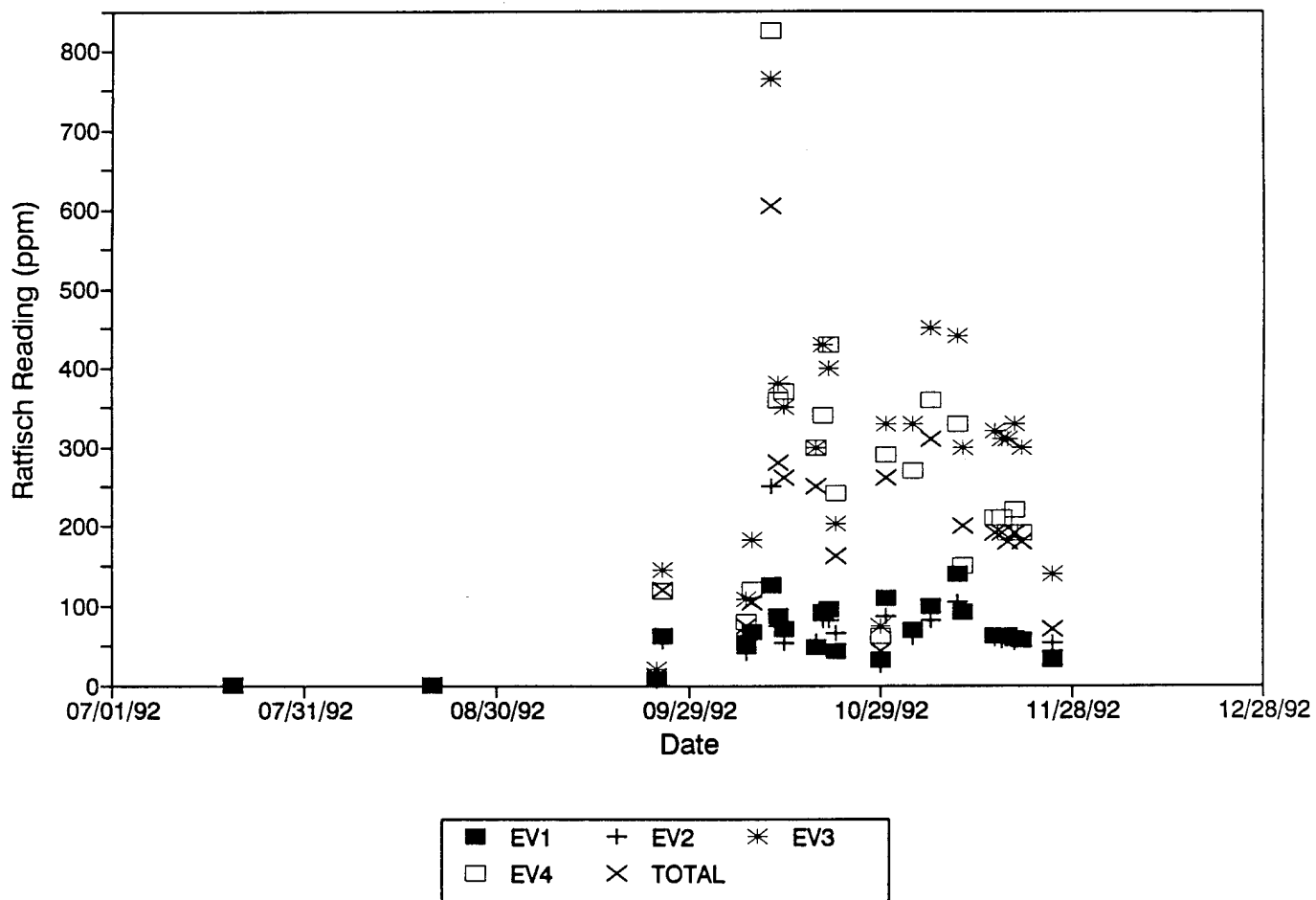

Figure 16
EFFECT OF VENT SPACING
ON UNIT COSTS

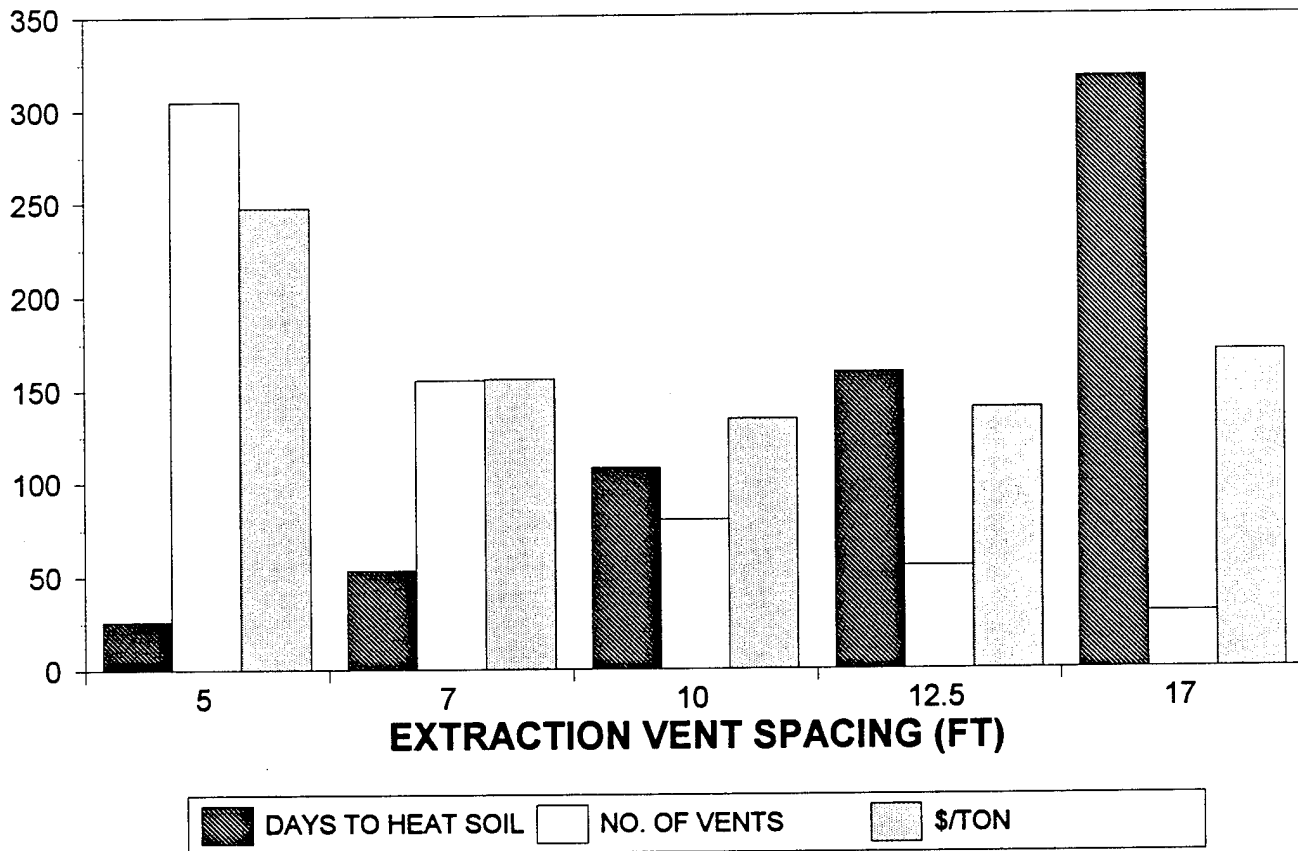
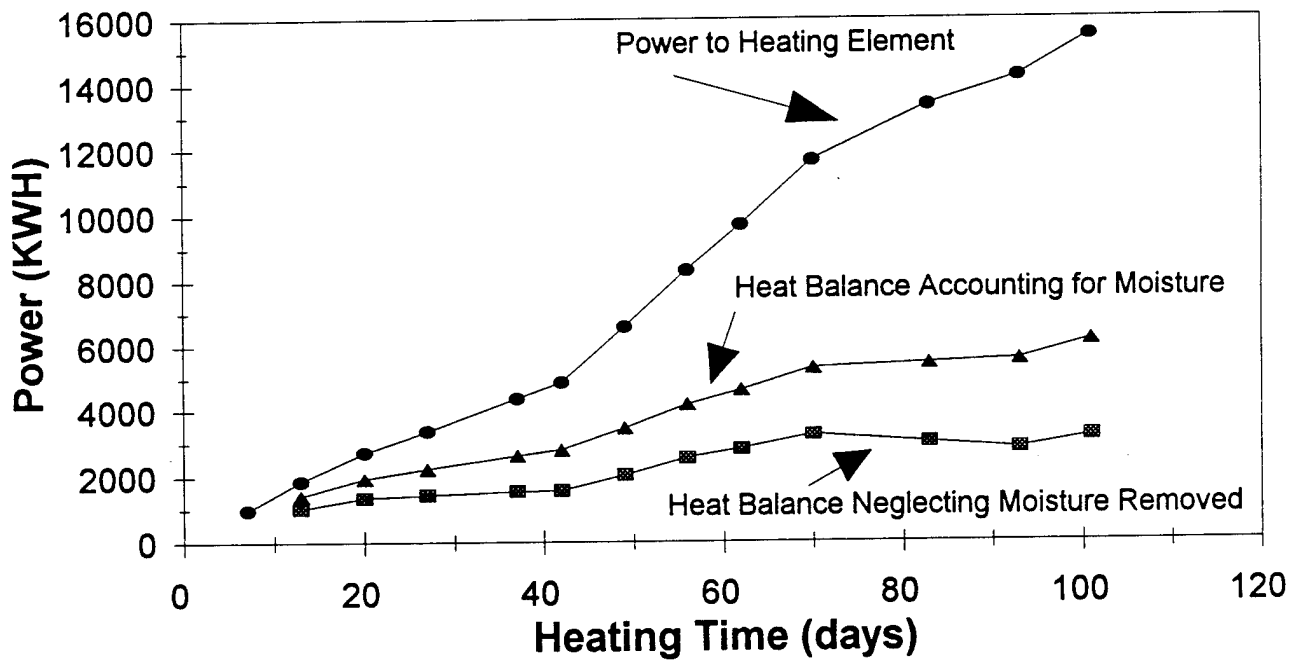
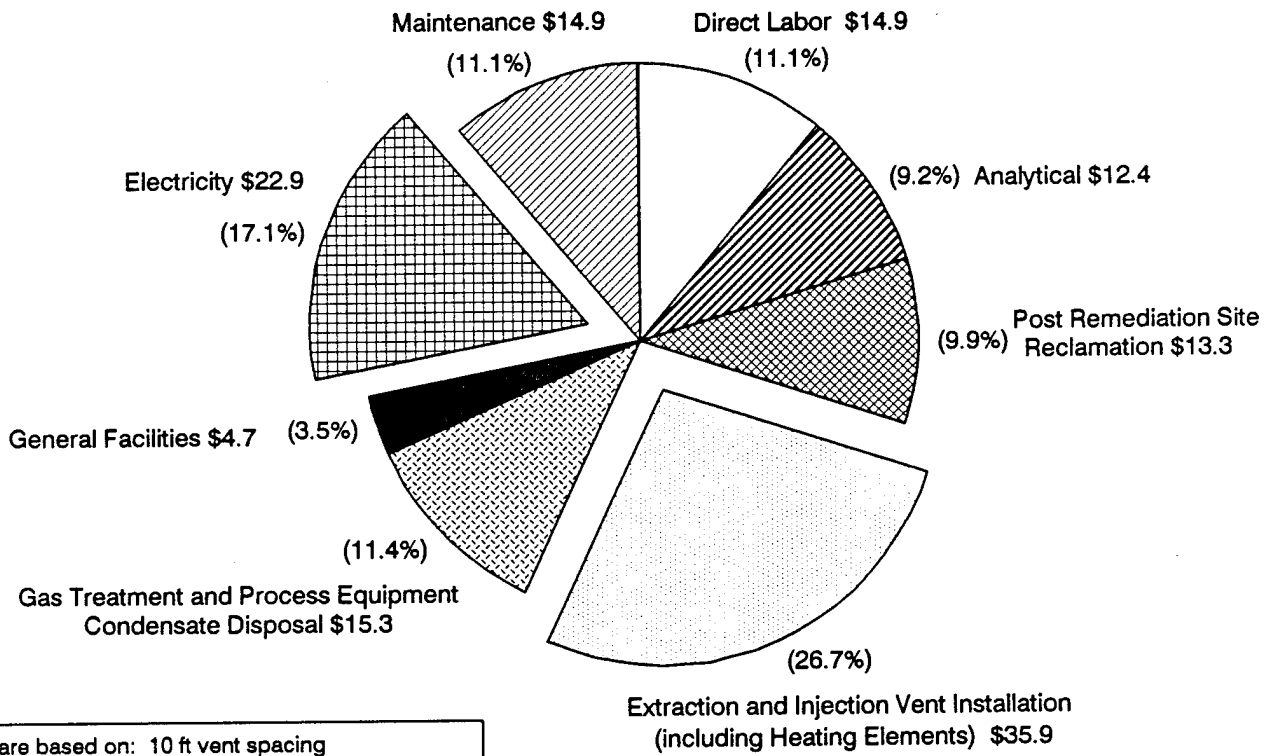

Figure 16a
Power Input



**Figure 17
Treatment Cost Breakdown**

\$134/Ton



Costs are based on: 10 ft vent spacing
70' x 100' module
10 ft contaminated zone thickness
10% by weight initial soil moisture
120 day remediation

TABLES

07/05/95

Table 4-1

EDSVEP SOIL PHYSICAL PROPERTIES RESULTS

SITE ID	EV1	EV1	EV2	EV2	EV3	EV3	EV3	EV4	EV4	EV4	IV1
SAMPLE DATE	04/28/92	04/28/92	04/28/92	04/28/92	04/28/92	04/28/92	04/28/92	04/28/92	04/28/92	04/28/92	04/28/92
TOP OF SAMPLE DEPTH	7.0	9.5	7.5	10.0	6.5	6.5	9.5	6.5	9.0	6.0	6.0
BOTTOM OF SAMPLE DEPTH	7.6	10.5	8.5	11.0	7.5	7.5	10.5	7.5	10.0	7.0	7.0
HYDRAULIC CONDUCTIVITY	5.706	5.932	0.879	1.112	0.071	0.071	0.477	1.987	0.064	0.064	0.046
TOC (%)	0.30	0.46	0.36	0.31	0.35	0.35	0.34	0.27	0.34	0.38	0.38
BULK DENSITY (GRAMS/CC)	1.40	1.12	1.18	1.54	1.19	1.19	1.02	1.54	1.61	1.22	1.22
% CF > 2.00 MM	<.1	<.1	<.1	<.1	<.1	<.1	<.1	<.1	<.1	<.1	<.1
% VCS 1 - 2 MM	2.0	1.2	0.8	2.4	2.7	2.7	2.2	0.4	2.9	2.7	2.7
% CS 0.5 - 1 MM	2.7	1.2	1.8	3.7	3.1	3.1	3.3	0.8	3.1	4.7	4.7
% MS 0.25 - 0.5 MM	10.4	6.3	6.3	8.8	12.2	12.2	7.1	1.6	10.6	9.2	9.2
% FS 0.1 - 0.25 MM	10.0	8.4	4.1	9.2	9.1	9.1	10.0	2.9	11.4	8.6	8.6
% VFS 0.05 - 0.1 MM	15.7	19.2	5.5	11.9	15.1	15.1	13.9	5.7	14.1	13.7	13.7
% SILT 0.002 - 0.05 MM	32	41	25	35	28	28	27	45	32	28	28
% CLAY < 0.002	28	23	56	29	30	30	37	44	26	33	33

Table 4-2

EDSVEP SOIL CHEMICAL ANALYSES

Siteid	Depth	File Type	Samptech	Sampdate	Fieldid	Method	Testname	Bool	Corvalue	Units	Flagcode
EV-1	6.50	CSO BORE U		04/16/92	EDSVEP	8260	111TCE	LT	0.010	UGG	
	7.60			04/15/92			LT	0.010	UGG		
	8.00			LT			0.010	UGG			
	10.50			LT			0.3	UGG			
	6.50			04/16/92			112TCE	LT	0.010	UGG	
	7.60			04/15/92			LT	0.010	UGG		
	8.00			LT			0.010	UGG			
	10.50			LT			0.3	UGG			
	6.50			04/16/92			11DCCE	LT	0.010	UGG	
	7.60			04/15/92			LT	0.010	UGG		
	8.00			LT			0.010	UGG			
	10.50			LT			0.3	UGG			
	6.50			04/16/92			11DCLE	LT	0.010	UGG	
	7.60			04/15/92			LT	0.010	UGG		
	8.00			LT			0.010	UGG			
	10.50			LT			0.3	UGG			
	6.50			04/16/92			11DCPE	LT	0.010	UGG	
	7.60			04/15/92			LT	0.010	UGG		
	8.00			LT			0.010	UGG			
	10.50			LT			0.3	UGG			
	6.50			04/16/92			123CPR	LT	0.010	UGG	
	7.60			04/15/92			LT	0.010	UGG		
	8.00			LT			0.010	UGG			
	10.50			LT			0.3	UGG			
	6.50			04/16/92			123TCB	LT	0.010	UGG	
	7.60			04/15/92			LT	0.010	UGG		
	8.00			LT			0.010	UGG			
	10.50			LT			0.3	UGG			
	6.50			04/16/92			124TCB	LT	0.010	UGG	
	7.60			04/15/92			LT	0.010	UGG		
	8.00			LT			0.010	UGG			
	10.50			LT			0.3	UGG			
	6.50			04/16/92			124TMB	LT	0.010	UGG	
	7.60			04/15/92			LT	0.010	UGG		
	8.00			LT			0.010	UGG			
	10.50			LT			0.3	UGG			
	6.50			04/16/92			12DBRE	LT	0.010	UGG	
	7.60			04/15/92			LT	0.010	UGG		
	8.00			LT			0.010	UGG			
	10.50			LT			0.3	UGG			
	6.50			04/16/92			12DCLB	LT	0.010	UGG	
	7.60			04/15/92			LT	0.010	UGG		
	8.00			LT			0.010	UGG			
	10.50			LT			0.3	UGG			
	6.50			04/16/92			12DCLE	LT	0.010	UGG	
	7.60			04/15/92			LT	0.010	UGG		
	8.00			LT			0.010	UGG			
	10.50			LT			0.3	UGG			
	6.50			04/16/92			12DCLP	LT	0.010	UGG	
	7.60			04/15/92			LT	0.010	UGG		
	8.00			LT			0.010	UGG			
	10.50			LT			0.3	UGG			
	6.50			04/16/92			135TMB	LT	0.010	UGG	
	7.60			04/15/92			LT	0.010	UGG		
	8.00			LT			0.010	UGG			
	10.50			LT			0.3	UGG			
	6.50			04/16/92			13DCLB	LT	0.010	UGG	
	7.60			04/15/92			LT	0.010	UGG		
	8.00			LT			0.010	UGG			
	10.50			LT			0.3	UGG			
	6.50			04/16/92			13DCLP	LT	0.010	UGG	
	7.60			04/15/92			LT	0.010	UGG		
	8.00			LT			0.010	UGG			
	10.50			LT			0.3	UGG			
	6.50			04/16/92			14DCLB	LT	0.010	UGG	
	7.60			04/15/92			LT	0.010	UGG		
	8.00			LT			0.010	UGG			
	10.50			LT			0.3	UGG			
	6.50			04/16/92			22DCLP	LT	0.010	UGG	
	7.60			04/15/92			LT	0.010	UGG		
	8.00			LT			0.010	UGG			
	10.50			LT			0.3	UGG			
	6.50			04/16/92			2CLT	LT	0.010	UGG	
	7.60			04/15/92			LT	0.010	UGG		
	8.00			LT			0.010	UGG			
	10.50			LT			0.3	UGG			
	6.50			04/16/92			3PT	LT	0.010	UGG	
	7.60			04/15/92			LT	0.010	UGG		
	8.00			LT			0.010	UGG			
	10.50			LT			0.3	UGG			
	6.50			04/16/92			4CLT	LT	0.010	UGG	
	7.60			04/15/92			LT	0.010	UGG		
	8.00			LT			0.010	UGG			
	10.50			LT			0.3	UGG			

EDSVEP SOIL CHEMICAL ANALYSES

Siteid	Depth	File Type	Samptech	Sampdate	Fieldid	Method	Testname	Bool	Corvalue	Units	Flagcode
	6.50			04/16/92			BCHPD	LT	0.010	UGG	
	7.60			04/15/92				LT	0.010	UGG	
	8.00							LT	0.010	UGG	
	10.50							LT	0.3	UGG	
	6.50			04/16/92			BRC6H5	LT	0.010	UGG	
	7.60			04/15/92				LT	0.010	UGG	
	8.00							LT	0.010	UGG	
	10.50							LT	0.3	UGG	
	6.50			04/16/92			BRCLM	LT	0.010	UGG	
	7.60			04/15/92				LT	0.010	UGG	
	8.00							LT	0.010	UGG	
	10.50							LT	0.3	UGG	
	6.50			04/16/92			BRDCLM	LT	0.010	UGG	
	7.60			04/15/92				LT	0.010	UGG	
	8.00							LT	0.010	UGG	
	10.50							LT	0.3	UGG	
	6.50			04/16/92			BUC6H5	LT	0.010	UGG	
	7.60			04/15/92				LT	0.010	UGG	
	8.00							LT	0.010	UGG	
	10.50							LT	0.3	UGG	
	6.50			04/16/92			C12DCE	LT	0.010	UGG	
	7.60			04/15/92				LT	0.010	UGG	
	8.00							LT	0.010	UGG	
	10.50							LT	0.3	UGG	
	6.50			04/16/92			C2H3CL	LT	0.010	UGG	
	7.60			04/15/92				LT	0.010	UGG	
	8.00							LT	0.010	UGG	
	10.50							LT	0.3	UGG	
	6.50			04/16/92			C2H5CL	LT	0.010	UGG	
	7.60			04/15/92				LT	0.010	UGG	
	8.00							LT	0.010	UGG	
	10.50							LT	0.3	UGG	
	6.50			04/16/92			C6H6	LT	0.010	UGG	
	7.60			04/15/92				LT	0.010	UGG	
	8.00							LT	0.010	UGG	
	10.50							LT	0.3	UGG	
	6.50			04/16/92			CCL2F2	LT	0.010	UGG	
	7.60			04/15/92				LT	0.010	UGG	
	8.00							LT	0.010	UGG	
	10.50							LT	0.3	UGG	
	6.50			04/16/92			CCL3F	LT	0.010	UGG	
	7.60			04/15/92				LT	0.010	UGG	
	8.00							LT	0.010	UGG	
	10.50							LT	0.3	UGG	
	6.50			04/16/92			CCL4	LT	0.010	UGG	
	7.60			04/15/92				LT	0.010	UGG	
	8.00							LT	0.010	UGG	
	10.50							LT	0.3	UGG	
	6.50			04/16/92			CH2CL2	LT	0.010	UGG	
	7.60			04/15/92				LT	0.010	UGG	
	8.00							LT	0.010	UGG	
	10.50							LT	0.3	UGG	
	6.50			04/16/92			CH3BR	LT	0.010	UGG	
	7.60			04/15/92				LT	0.010	UGG	
	8.00							LT	0.010	UGG	
	10.50							LT	0.3	UGG	
	6.50			04/16/92			CH3CL	LT	0.010	UGG	
	7.60			04/15/92				LT	0.010	UGG	
	8.00							LT	0.010	UGG	
	10.50							LT	0.3	UGG	
	6.50			04/16/92			CHBR3	LT	0.010	UGG	
	7.60			04/15/92				LT	0.010	UGG	
	8.00							LT	0.010	UGG	
	10.50							LT	0.3	UGG	
	6.50			04/16/92			CHCL3	LT	0.010	UGG	
	7.60			04/15/92				LT	0.010	UGG	
	8.00							LT	0.010	UGG	
	10.50							LT	0.3	UGG	
	6.50			04/16/92			CLC6H5	LT	0.010	UGG	
	7.60			04/15/92				LT	0.010	UGG	
	8.00							LT	0.010	UGG	
	10.50							LT	0.3	UGG	
	6.50			04/16/92			DBCP	LT	0.010	UGG	
	7.60			04/15/92				LT	0.010	UGG	
	8.00							LT	0.010	UGG	
	10.50							LT	0.3	UGG	
	6.50			04/16/92			DBRCLM	LT	0.010	UGG	
	7.60			04/15/92				LT	0.010	UGG	
	8.00							LT	0.010	UGG	
	10.50							LT	0.3	UGG	
	6.50			04/16/92			DBRM	LT	0.010	UGG	
	7.60			04/15/92				LT	0.010	UGG	
	8.00							LT	0.010	UGG	
	10.50							LT	0.3	UGG	

EDSVEP SOIL CHEMICAL ANALYSES

Siteid	Depth	File Type	Samptech	Sampdate	Fieldid	Method	Testname	Bool	Corvalue	Units	Flagcode
	6.50			04/16/92			DCPD	LT	0.010	UGG	
	7.60			04/15/92				LT	0.010	UGG	
	8.00							LT	0.010	UGG	
	10.50								4000.	UGG	
	6.50			04/16/92			ETC6H5	LT	0.010	UGG	
	7.60			04/15/92				LT	0.010	UGG	
	8.00							LT	0.010	UGG	
	10.50							LT	0.3	UGG	
	6.50			04/16/92			HCBD	LT	0.010	UGG	
	7.60			04/15/92				LT	0.010	UGG	
	8.00							LT	0.010	UGG	
	10.50							LT	0.3	UGG	
	6.50			04/16/92			ISOPBZ	LT	0.010	UGG	
	7.60			04/15/92				LT	0.010	UGG	
	8.00							LT	0.010	UGG	
	10.50							LT	0.3	UGG	
	6.50			04/16/92			MEC6H5	LT	0.010	UGG	
	7.60			04/15/92				LT	0.010	UGG	
	8.00							LT	0.010	UGG	
	10.50							LT	0.3	UGG	
	6.50			04/16/92			NAP	LT	0.010	UGG	
	7.60			04/15/92				LT	0.010	UGG	
	8.00							LT	0.010	UGG	
	10.50							LT	0.3	UGG	
	6.50			04/16/92			PRC6H5	LT	0.010	UGG	
	7.60			04/15/92				LT	0.010	UGG	
	8.00							LT	0.010	UGG	
	10.50							LT	0.3	UGG	
	6.50			04/16/92			SBBEN	LT	0.010	UGG	
	7.60			04/15/92				LT	0.010	UGG	
	8.00							LT	0.010	UGG	
	10.50							LT	0.3	UGG	
	6.50			04/16/92			STYR	LT	0.010	UGG	
	7.60			04/15/92				LT	0.010	UGG	
	8.00							LT	0.010	UGG	
	10.50							LT	0.3	UGG	
	6.50			04/16/92			T12DCE	LT	0.010	UGG	
	7.60			04/15/92				LT	0.010	UGG	
	8.00							LT	0.010	UGG	
	10.50							LT	0.3	UGG	
	6.50			04/16/92			TBBEN	LT	0.010	UGG	
	7.60			04/15/92				LT	0.010	UGG	
	8.00							LT	0.010	UGG	
	10.50							LT	0.3	UGG	
	6.50			04/16/92			TCLEA	LT	0.010	UGG	
	7.60			04/15/92				LT	0.010	UGG	
	8.00							LT	0.010	UGG	
	10.50							LT	0.3	UGG	
	6.50			04/16/92			TCLEE	LT	0.010	UGG	
	7.60			04/15/92				LT	0.010	UGG	
	8.00							LT	0.010	UGG	
	10.50							LT	0.3	UGG	
	6.50			04/16/92			TRCLE	LT	0.010	UGG	
	7.60			04/15/92				LT	0.010	UGG	
	8.00							LT	0.010	UGG	
	10.50							LT	0.3	UGG	
	6.50			04/16/92			XYLEN	LT	0.020	UGG	
	7.60			04/15/92				LT	0.020	UGG	
	8.00							LT	0.020	UGG	
	10.50							LT	0.5	UGG	
EV-2	6.00			04/17/92			111TCE	LT	0.010	UGG	
	7.00							LT	0.010	UGG	
	8.50							LT	0.010	UGG	
	9.50							LT	0.010	UGG	
	11.00							LT	0.05	UGG	
	6.00						112TCE	LT	0.010	UGG	
	7.00							LT	0.010	UGG	
	8.50							LT	0.010	UGG	
	9.50							LT	0.010	UGG	
	11.00							LT	0.05	UGG	
	6.00						11DCE	LT	0.010	UGG	
	7.00							LT	0.010	UGG	
	8.50							LT	0.010	UGG	
	9.50							LT	0.010	UGG	
	11.00							LT	0.05	UGG	
	6.00						11DCLE	LT	0.010	UGG	
	7.00							LT	0.010	UGG	
	8.50							LT	0.010	UGG	
	9.50							LT	0.010	UGG	
	11.00							LT	0.05	UGG	
	6.00						11DCPE	LT	0.010	UGG	
	7.00							LT	0.010	UGG	
	8.50							LT	0.010	UGG	
	9.50							LT	0.010	UGG	

EDSVEP SOIL CHEMICAL ANALYSES

Siteid	Depth	File Type	Samptech	Sampdate	Fieldid	Method	Testname	Bool	Corvalue	Units	Flagcode
	11.00							LT	0.05	UGG	
	6.00						123CPR	LT	0.010	UGG	
	7.00							LT	0.010	UGG	
	8.50							LT	0.010	UGG	
	9.50							LT	0.010	UGG	
	11.00							LT	0.05	UGG	
	6.00						123TCB	LT	0.010	UGG	
	7.00							LT	0.010	UGG	
	8.50							LT	0.010	UGG	
	9.50							LT	0.010	UGG	
	11.00							LT	0.05	UGG	
	6.00						124TCB	LT	0.010	UGG	
	7.00							LT	0.010	UGG	
	8.50							LT	0.010	UGG	
	9.50							LT	0.010	UGG	
	11.00							LT	0.05	UGG	
	6.00						124TMB	LT	0.010	UGG	
	7.00							LT	0.010	UGG	
	8.50							LT	0.010	UGG	
	9.50							LT	0.010	UGG	
	11.00							LT	0.05	UGG	
	6.00						12DBRE	LT	0.010	UGG	
	7.00							LT	0.010	UGG	
	8.50							LT	0.010	UGG	
	9.50							LT	0.010	UGG	
	11.00							LT	0.05	UGG	
	6.00						12DCLB	LT	0.010	UGG	
	7.00							LT	0.010	UGG	
	8.50							LT	0.010	UGG	
	9.50							LT	0.010	UGG	
	11.00							LT	0.05	UGG	
	6.00						12DCLC	LT	0.010	UGG	
	7.00							LT	0.010	UGG	
	8.50							LT	0.010	UGG	
	9.50							LT	0.010	UGG	
	11.00							LT	0.05	UGG	
	6.00						12DCLP	LT	0.010	UGG	
	7.00							LT	0.010	UGG	
	8.50							LT	0.010	UGG	
	9.50							LT	0.010	UGG	
	11.00							LT	0.05	UGG	
	6.00						135TMB	LT	0.010	UGG	
	7.00							LT	0.010	UGG	
	8.50							LT	0.010	UGG	
	9.50							LT	0.010	UGG	
	11.00							LT	0.05	UGG	
	6.00						13DCLB	LT	0.010	UGG	
	7.00							LT	0.010	UGG	
	8.50							LT	0.010	UGG	
	9.50							LT	0.010	UGG	
	11.00							LT	0.05	UGG	
	6.00						13DCLP	LT	0.010	UGG	
	7.00							LT	0.010	UGG	
	8.50							LT	0.010	UGG	
	9.50							LT	0.010	UGG	
	11.00							LT	0.05	UGG	
	6.00						14DCLB	LT	0.010	UGG	
	7.00							LT	0.010	UGG	
	8.50							LT	0.010	UGG	
	9.50							LT	0.010	UGG	
	11.00							LT	0.05	UGG	
	6.00						22DCLP	LT	0.010	UGG	
	7.00							LT	0.010	UGG	
	8.50							LT	0.010	UGG	
	9.50							LT	0.010	UGG	
	11.00							LT	0.05	UGG	
	6.00						2CLT	LT	0.010	UGG	
	7.00							LT	0.010	UGG	
	8.50							LT	0.010	UGG	
	9.50							LT	0.010	UGG	
	11.00							LT	0.05	UGG	
	6.00						3PT	LT	0.010	UGG	
	7.00							LT	0.010	UGG	
	8.50							LT	0.010	UGG	
	9.50							LT	0.010	UGG	
	11.00							LT	0.05	UGG	
	6.00						4CLT	LT	0.010	UGG	
	7.00							LT	0.010	UGG	
	8.50							LT	0.010	UGG	
	9.50							LT	0.010	UGG	
	11.00							LT	0.05	UGG	
	6.00						BCHPD	LT	0.010	UGG	
	7.00							LT	0.010	UGG	
	8.50							LT	0.010	UGG	

EDSVEP SOIL CHEMICAL ANALYSES

Siteid	Depth	File Type	Samptech	Sampdate	Fieldid	Method	Testname	Bool	Corvalue	Units	Flagcode
	9.50							LT	0.010	UGG	
	11.00							LT	0.05	UGG	
	6.00						BRC6H5	LT	0.010	UGG	
	7.00							LT	0.010	UGG	
	8.50							LT	0.010	UGG	
	9.50							LT	0.010	UGG	
	11.00							LT	0.05	UGG	
	6.00						BRCLM	LT	0.010	UGG	
	7.00							LT	0.010	UGG	
	8.50							LT	0.010	UGG	
	9.50							LT	0.010	UGG	
	11.00							LT	0.05	UGG	
	6.00						BRDCLM	LT	0.010	UGG	
	7.00							LT	0.010	UGG	
	8.50							LT	0.010	UGG	
	9.50							LT	0.010	UGG	
	11.00							LT	0.05	UGG	
	6.00						BUC6H5	LT	0.010	UGG	
	7.00							LT	0.010	UGG	
	8.50							LT	0.010	UGG	
	9.50							LT	0.010	UGG	
	11.00							LT	0.05	UGG	
	6.00						C12DCE	LT	0.010	UGG	
	7.00							LT	0.010	UGG	
	8.50							LT	0.010	UGG	
	9.50							LT	0.010	UGG	
	11.00							LT	0.05	UGG	
	6.00						C2H3CL	LT	0.010	UGG	
	7.00							LT	0.010	UGG	
	8.50							LT	0.010	UGG	
	9.50							LT	0.010	UGG	
	11.00							LT	0.05	UGG	
	6.00						C2H5CL	LT	0.010	UGG	
	7.00							LT	0.010	UGG	
	8.50							LT	0.010	UGG	
	9.50							LT	0.010	UGG	
	11.00							LT	0.05	UGG	
	6.00						C6H6	LT	0.010	UGG	
	7.00							LT	0.010	UGG	
	8.50							LT	0.010	UGG	
	9.50							LT	0.010	UGG	
	11.00							LT	0.05	UGG	
	6.00						CCL2F2	LT	0.010	UGG	
	7.00							LT	0.010	UGG	
	8.50							LT	0.010	UGG	
	9.50							LT	0.010	UGG	
	11.00							LT	0.05	UGG	
	6.00						CCL3F	LT	0.010	UGG	
	7.00							LT	0.010	UGG	
	8.50							LT	0.010	UGG	
	9.50							LT	0.010	UGG	
	11.00							LT	0.05	UGG	
	6.00						CCL4	LT	0.010	UGG	
	7.00							LT	0.010	UGG	
	8.50							LT	0.010	UGG	
	9.50							LT	0.010	UGG	
	11.00							LT	0.05	UGG	
	6.00						CH2CL2	LT	0.010	UGG	
	7.00							LT	0.010	UGG	
	8.50							LT	0.010	UGG	
	9.50							LT	0.010	UGG	
	11.00							LT	0.05	UGG	
	6.00						CH3BR	LT	0.010	UGG	
	7.00							LT	0.010	UGG	
	8.50							LT	0.010	UGG	
	9.50							LT	0.010	UGG	
	11.00							LT	0.05	UGG	
	6.00						CH3CL	LT	0.010	UGG	
	7.00							LT	0.010	UGG	
	8.50							LT	0.010	UGG	
	9.50							LT	0.010	UGG	
	11.00							LT	0.05	UGG	
	6.00						CHBR3	LT	0.010	UGG	
	7.00							LT	0.010	UGG	
	8.50							LT	0.010	UGG	
	9.50							LT	0.010	UGG	
	11.00							LT	0.05	UGG	
	6.00						CHCL3	LT	0.010	UGG	
	7.00							LT	0.010	UGG	
	8.50							LT	0.010	UGG	
	9.50							LT	0.010	UGG	
	11.00							LT	0.05	UGG	
	6.00						CLC6H5	LT	0.010	UGG	
	7.00							LT	0.010	UGG	

EDSVEP SOIL CHEMICAL ANALYSES

Siteid	Depth	File Type	Samptech	Sampdate	Fieldid	Method	Testname	Bool	Corvalue	Units	Flagcode
	8.50							LT	0.010	UGG	
	9.50							LT	0.010	UGG	
	11.00							LT	0.05	UGG	
	6.00					DBCP		LT	0.010	UGG	
	7.00							LT	0.010	UGG	
	8.50							LT	0.010	UGG	
	9.50							LT	0.010	UGG	
	11.00							LT	0.05	UGG	
	6.00					DBRCLM		LT	0.010	UGG	
	7.00							LT	0.010	UGG	
	8.50							LT	0.010	UGG	
	9.50							LT	0.010	UGG	
	11.00							LT	0.05	UGG	
	6.00					DBRM		LT	0.010	UGG	
	7.00							LT	0.010	UGG	
	8.50							LT	0.010	UGG	
	9.50							LT	0.010	UGG	
	11.00							LT	0.05	UGG	
	6.00					DCPD		LT	0.010	UGG	
	7.00							LT	0.010	UGG	
	8.50							LT	0.010	UGG	
	9.50							LT	0.010	UGG	
	11.00								0.5	UGG	
	6.00					ETC6H5		LT	0.010	UGG	
	7.00							LT	0.010	UGG	
	8.50							LT	0.010	UGG	
	9.50							LT	0.010	UGG	
	11.00							LT	0.05	UGG	
	6.00					HCBD		LT	0.010	UGG	
	7.00							LT	0.010	UGG	
	8.50							LT	0.010	UGG	
	9.50							LT	0.010	UGG	
	11.00							LT	0.05	UGG	
	6.00					ISOPBZ		LT	0.010	UGG	
	7.00							LT	0.010	UGG	
	8.50							LT	0.010	UGG	
	9.50							LT	0.010	UGG	
	11.00							LT	0.05	UGG	
	6.00					MEC6H5		LT	0.010	UGG	
	7.00							LT	0.010	UGG	
	8.50							LT	0.010	UGG	
	9.50							LT	0.010	UGG	
	11.00							LT	0.05	UGG	
	6.00					NAP		LT	0.010	UGG	
	7.00							LT	0.010	UGG	
	8.50							LT	0.010	UGG	
	9.50							LT	0.010	UGG	
	11.00							LT	0.05	UGG	
	6.00					PRC6H5		LT	0.010	UGG	
	7.00							LT	0.010	UGG	
	8.50							LT	0.010	UGG	
	9.50							LT	0.010	UGG	
	11.00							LT	0.05	UGG	
	6.00					SBBEN		LT	0.010	UGG	
	7.00							LT	0.010	UGG	
	8.50							LT	0.010	UGG	
	9.50							LT	0.010	UGG	
	11.00							LT	0.05	UGG	
	6.00					STYR		LT	0.010	UGG	
	7.00							LT	0.010	UGG	
	8.50							LT	0.010	UGG	
	9.50							LT	0.010	UGG	
	11.00							LT	0.05	UGG	
	6.00					T12DCE		LT	0.010	UGG	
	7.00							LT	0.010	UGG	
	8.50							LT	0.010	UGG	
	9.50							LT	0.010	UGG	
	11.00							LT	0.05	UGG	
	6.00					TBBEN		LT	0.010	UGG	
	7.00							LT	0.010	UGG	
	8.50							LT	0.010	UGG	
	9.50							LT	0.010	UGG	
	11.00							LT	0.05	UGG	
	6.00					TCLEA		LT	0.010	UGG	
	7.00							LT	0.010	UGG	
	8.50							LT	0.010	UGG	
	9.50							LT	0.010	UGG	
	11.00							LT	0.05	UGG	
	6.00					TCLEE		LT	0.010	UGG	
	7.00							LT	0.010	UGG	
	8.50							LT	0.010	UGG	
	9.50							LT	0.010	UGG	
	11.00							LT	0.05	UGG	
	6.00					TRCLE		LT	0.010	UGG	
	7.00							LT	0.010	UGG	
	8.50							LT	0.010	UGG	
	9.50							LT	0.010	UGG	
	11.00							LT	0.05	UGG	
	6.00							LT	0.010	UGG	

EDSVEP SOIL CHEMICAL ANALYSES

Siteid	Depth	File Type	Samptech	Sampdate	Fieldid	Method	Testname	Bool	Corvalue	Units	Flagcode
	7.00							LT	0.010	UGG	
	8.50							LT	0.010	UGG	
	9.50							LT	0.010	UGG	
	11.00							LT	0.05	UGG	
	6.00					XYLEN		LT	0.020	UGG	
	7.00							LT	0.020	UGG	
	8.50							LT	0.020	UGG	
	9.50							LT	0.020	UGG	
	11.00							LT	0.1	UGG	
EV-3	6.00			04/16/92		111TCE		LT	0.010	UGG	
	7.50							LT	0.010	UGG	
	8.00							LT	0.010	UGG	
	8.50							LT	0.010	UGG	
	9.00							LT	0.010	UGG	
	10.50							LT	0.010	UGG	
	6.00					112TCE		LT	0.010	UGG	
	7.50							LT	0.010	UGG	
	8.00							LT	0.010	UGG	
	8.50							LT	0.010	UGG	
	9.00							LT	0.010	UGG	
	10.50							LT	0.010	UGG	
	6.00					11DCCE		LT	0.010	UGG	
	7.50							LT	0.010	UGG	
	8.00							LT	0.010	UGG	
	8.50							LT	0.010	UGG	
	9.00							LT	0.010	UGG	
	10.50							LT	0.010	UGG	
	6.00					11DCLE		LT	0.010	UGG	
	7.50							LT	0.010	UGG	
	8.00							LT	0.010	UGG	
	8.50							LT	0.010	UGG	
	9.00							LT	0.010	UGG	
	10.50							LT	0.010	UGG	
	6.00					11DCPE		LT	0.010	UGG	
	7.50							LT	0.010	UGG	
	8.00							LT	0.010	UGG	
	8.50							LT	0.010	UGG	
	9.00							LT	0.010	UGG	
	10.50							LT	0.010	UGG	
	6.00					123CPR		LT	0.010	UGG	
	7.50							LT	0.010	UGG	
	8.00							LT	0.010	UGG	
	8.50							LT	0.010	UGG	
	9.00							LT	0.010	UGG	
	10.50							LT	0.010	UGG	
	6.00					123TCB		LT	0.010	UGG	
	7.50							LT	0.010	UGG	
	8.00							LT	0.010	UGG	
	8.50							LT	0.010	UGG	
	9.00							LT	0.010	UGG	
	10.50							LT	0.010	UGG	
	6.00					124TCB		LT	0.010	UGG	
	7.50							LT	0.010	UGG	
	8.00							LT	0.010	UGG	
	8.50							LT	0.010	UGG	
	9.00							LT	0.010	UGG	
	10.50							LT	0.010	UGG	
	6.00					124TMB		LT	0.010	UGG	
	7.50							LT	0.010	UGG	
	8.00							LT	0.010	UGG	
	8.50							LT	0.010	UGG	
	9.00							LT	0.010	UGG	
	10.50							LT	0.010	UGG	
	6.00					12DBRE		LT	0.010	UGG	
	7.50							LT	0.010	UGG	
	8.00							LT	0.010	UGG	
	8.50							LT	0.010	UGG	
	9.00							LT	0.010	UGG	
	10.50							LT	0.010	UGG	
	6.00					12DCLB		LT	0.010	UGG	
	7.50							LT	0.010	UGG	
	8.00							LT	0.010	UGG	
	8.50							LT	0.010	UGG	
	9.00							LT	0.010	UGG	
	10.50							LT	0.010	UGG	
	6.00					12DCLE		LT	0.010	UGG	
	7.50							LT	0.010	UGG	
	8.00							LT	0.010	UGG	
	8.50							LT	0.010	UGG	
	9.00							LT	0.010	UGG	
	10.50							LT	0.010	UGG	
	6.00					12DCLP		LT	0.010	UGG	
	7.50							LT	0.010	UGG	
	8.00							LT	0.010	UGG	

EDSVEP SOIL CHEMICAL ANALYSES

Siteid	Depth	File Type	Samptech	Samptime	Fieldid	Method	Testname	Bool	Corvalue	Units	Flagcode
	8.50							LT	0.010	UGG	
	9.00							LT	0.010	UGG	
	10.50							LT	0.010	UGG	
	6.00						135TMB	LT	0.010	UGG	
	7.50							LT	0.010	UGG	
	8.00							LT	0.010	UGG	
	8.50							LT	0.010	UGG	
	9.00							LT	0.010	UGG	
	10.50							LT	0.010	UGG	
	6.00						13DCLB	LT	0.010	UGG	
	7.50							LT	0.010	UGG	
	8.00							LT	0.010	UGG	
	8.50							LT	0.010	UGG	
	9.00							LT	0.010	UGG	
	10.50							LT	0.010	UGG	
	6.00						13DCLP	LT	0.010	UGG	
	7.50							LT	0.010	UGG	
	8.00							LT	0.010	UGG	
	8.50							LT	0.010	UGG	
	9.00							LT	0.010	UGG	
	10.50							LT	0.010	UGG	
	6.00						14DCLB	LT	0.010	UGG	
	7.50							LT	0.010	UGG	
	8.00							LT	0.010	UGG	
	8.50							LT	0.010	UGG	
	9.00							LT	0.010	UGG	
	10.50							LT	0.010	UGG	
	6.00						22DCLP	LT	0.010	UGG	
	7.50							LT	0.010	UGG	
	8.00							LT	0.010	UGG	
	8.50							LT	0.010	UGG	
	9.00							LT	0.010	UGG	
	10.50							LT	0.010	UGG	
	6.00						2CLT	LT	0.010	UGG	
	7.50							LT	0.010	UGG	
	8.00							LT	0.010	UGG	
	8.50							LT	0.010	UGG	
	9.00							LT	0.010	UGG	
	10.50							LT	0.010	UGG	
	6.00						3PT	LT	0.010	UGG	
	7.50							LT	0.010	UGG	
	8.00							LT	0.010	UGG	
	8.50							LT	0.010	UGG	
	9.00							LT	0.010	UGG	
	10.50							LT	0.010	UGG	
	6.00						4CLT	LT	0.010	UGG	
	7.50							LT	0.010	UGG	
	8.00							LT	0.010	UGG	
	8.50							LT	0.010	UGG	
	9.00							LT	0.010	UGG	
	10.50							LT	0.010	UGG	
	6.00						BCHPD	LT	0.010	UGG	
	7.50							LT	0.010	UGG	
	8.00							LT	0.010	UGG	
	8.50							LT	0.010	UGG	
	9.00							LT	0.010	UGG	
	10.50							LT	0.010	UGG	
	6.00						BRC6H5	LT	0.010	UGG	
	7.50							LT	0.010	UGG	
	8.00							LT	0.010	UGG	
	8.50							LT	0.010	UGG	
	9.00							LT	0.010	UGG	
	10.50							LT	0.010	UGG	
	6.00						BRCLM	LT	0.010	UGG	
	7.50							LT	0.010	UGG	
	8.00							LT	0.010	UGG	
	8.50							LT	0.010	UGG	
	9.00							LT	0.010	UGG	
	10.50							LT	0.010	UGG	
	6.00						BRDCLM	LT	0.010	UGG	
	7.50							LT	0.010	UGG	
	8.00							LT	0.010	UGG	
	8.50							LT	0.010	UGG	
	9.00							LT	0.010	UGG	
	10.50							LT	0.010	UGG	
	6.00						BUC6H5	LT	0.010	UGG	
	7.50							LT	0.010	UGG	
	8.00							LT	0.010	UGG	
	8.50							LT	0.010	UGG	
	9.00							LT	0.010	UGG	
	10.50							LT	0.010	UGG	
	6.00						C12DCE	LT	0.010	UGG	
	7.50							LT	0.010	UGG	
	8.00							LT	0.010	UGG	

EDSVEP SOIL CHEMICAL ANALYSES

Siteid	Depth	File Type	Samptech	Sampdate	Fieldid	Method	Testname	Bool	Corvalue	Units	Flagcode
	8.50							LT	0.010	UGG	
	9.00							LT	0.010	UGG	
	10.50							LT	0.010	UGG	
	6.00						C2H3CL	LT	0.010	UGG	
	7.50							LT	0.010	UGG	
	8.00							LT	0.010	UGG	
	8.50							LT	0.010	UGG	
	9.00							LT	0.010	UGG	
	10.50							LT	0.010	UGG	
	6.00						C2H5CL	LT	0.010	UGG	
	7.50							LT	0.010	UGG	
	8.00							LT	0.010	UGG	
	8.50							LT	0.010	UGG	
	9.00							LT	0.010	UGG	
	10.50							LT	0.010	UGG	
	6.00						C6H6	LT	0.010	UGG	
	7.50							LT	0.010	UGG	
	8.00							LT	0.010	UGG	
	8.50							LT	0.010	UGG	
	9.00							LT	0.010	UGG	
	10.50							LT	0.010	UGG	
	6.00						CCL2F2	LT	0.010	UGG	
	7.50							LT	0.010	UGG	
	8.00							LT	0.010	UGG	
	8.50							LT	0.010	UGG	
	9.00							LT	0.010	UGG	
	10.50							LT	0.010	UGG	
	6.00						CCL3F	LT	0.010	UGG	
	7.50							LT	0.010	UGG	
	8.00							LT	0.010	UGG	
	8.50							LT	0.010	UGG	
	9.00							LT	0.010	UGG	
	10.50							LT	0.010	UGG	
	6.00						CCL4	LT	0.010	UGG	
	7.50							LT	0.010	UGG	
	8.00							LT	0.010	UGG	
	8.50							LT	0.010	UGG	
	9.00							LT	0.010	UGG	
	10.50							LT	0.010	UGG	
	6.00						CH2CL2	LT	0.010	UGG	
	7.50							LT	0.010	UGG	
	8.00							LT	0.010	UGG	
	8.50							LT	0.010	UGG	
	9.00							LT	0.010	UGG	
	10.50							LT	0.010	UGG	
	6.00						CH3BR	LT	0.010	UGG	
	7.50							LT	0.010	UGG	
	8.00							LT	0.010	UGG	
	8.50							LT	0.010	UGG	
	9.00							LT	0.010	UGG	
	10.50							LT	0.010	UGG	
	6.00						CH3CL	LT	0.010	UGG	
	7.50							LT	0.010	UGG	
	8.00							LT	0.010	UGG	
	8.50							LT	0.010	UGG	
	9.00							LT	0.010	UGG	
	10.50							LT	0.010	UGG	
	6.00						CHBR3	LT	0.010	UGG	
	7.50							LT	0.010	UGG	
	8.00							LT	0.010	UGG	
	8.50							LT	0.010	UGG	
	9.00							LT	0.010	UGG	
	10.50							LT	0.010	UGG	
	6.00						CHCL3	LT	0.010	UGG	
	7.50							LT	0.010	UGG	
	8.00							LT	0.010	UGG	
	8.50							LT	0.010	UGG	
	9.00							LT	0.010	UGG	
	10.50							LT	0.010	UGG	
	6.00						CLC6H5	LT	0.010	UGG	
	7.50							LT	0.010	UGG	
	8.00							LT	0.010	UGG	
	8.50							LT	0.010	UGG	
	9.00							LT	0.010	UGG	
	10.50							LT	0.010	UGG	
	6.00						DBCP	LT	0.010	UGG	
	7.50							LT	0.010	UGG	
	8.00							LT	0.010	UGG	
	8.50							LT	0.010	UGG	
	9.00							LT	0.010	UGG	
	10.50							LT	0.010	UGG	
	6.00						DBRCLM	LT	0.010	UGG	
	7.50							LT	0.010	UGG	
	8.00							LT	0.010	UGG	

EDSVEP SOIL CHEMICAL ANALYSES

Siteid	Depth	File Type	Samptech	Sampdate	Fieldid	Method	Testname	Bool	Corvalue	Units	Flagcode
	8.50							LT	0.010	UGG	
	9.00							LT	0.010	UGG	
	10.50							LT	0.010	UGG	
	6.00					DBRM		LT	0.010	UGG	
	7.50							LT	0.010	UGG	
	8.00							LT	0.010	UGG	
	8.50							LT	0.010	UGG	
	9.00							LT	0.010	UGG	
	10.50							LT	0.010	UGG	
	6.00					DCPD		LT	0.010	UGG	
	7.50							LT	0.010	UGG	
	8.00							LT	0.010	UGG	
	8.50							LT	0.010	UGG	
	9.00							LT	0.010	UGG	
	10.50							LT	0.010	UGG	
	6.00					ETC6H5		LT	0.010	UGG	
	7.50							LT	0.010	UGG	
	8.00							LT	0.010	UGG	
	8.50							LT	0.010	UGG	
	9.00							LT	0.010	UGG	
	10.50							LT	0.010	UGG	
	6.00					HCBD		LT	0.010	UGG	
	7.50							LT	0.010	UGG	
	8.00							LT	0.010	UGG	
	8.50							LT	0.010	UGG	
	9.00							LT	0.010	UGG	
	10.50							LT	0.010	UGG	
	6.00					ISOPBZ		LT	0.010	UGG	
	7.50							LT	0.010	UGG	
	8.00							LT	0.010	UGG	
	8.50							LT	0.010	UGG	
	9.00							LT	0.010	UGG	
	10.50							LT	0.010	UGG	
	6.00					MEC6H5		LT	0.010	UGG	
	7.50							LT	0.010	UGG	
	8.00							LT	0.010	UGG	
	8.50							LT	0.010	UGG	
	9.00							LT	0.010	UGG	
	10.50							LT	0.010	UGG	
	6.00					NAP		LT	0.010	UGG	
	7.50							LT	0.010	UGG	
	8.00							LT	0.010	UGG	
	8.50							LT	0.010	UGG	
	9.00							LT	0.010	UGG	
	10.50							LT	0.010	UGG	
	6.00					PRC6H5		LT	0.010	UGG	
	7.50							LT	0.010	UGG	
	8.00							LT	0.010	UGG	
	8.50							LT	0.010	UGG	
	9.00							LT	0.010	UGG	
	10.50							LT	0.010	UGG	
	6.00					SBEN		LT	0.010	UGG	
	7.50							LT	0.010	UGG	
	8.00							LT	0.010	UGG	
	8.50							LT	0.010	UGG	
	9.00							LT	0.010	UGG	
	10.50							LT	0.010	UGG	
	6.00					STYR		LT	0.010	UGG	
	7.50							LT	0.010	UGG	
	8.00							LT	0.010	UGG	
	8.50							LT	0.010	UGG	
	9.00							LT	0.010	UGG	
	10.50							LT	0.010	UGG	
	6.00					T12DCE		LT	0.010	UGG	
	7.50							LT	0.010	UGG	
	8.00							LT	0.010	UGG	
	8.50							LT	0.010	UGG	
	9.00							LT	0.010	UGG	
	10.50							LT	0.010	UGG	
	6.00					TBBEN		LT	0.010	UGG	
	7.50							LT	0.010	UGG	
	8.00							LT	0.010	UGG	
	8.50							LT	0.010	UGG	
	9.00							LT	0.010	UGG	
	10.50							LT	0.010	UGG	
	6.00					TCLEA		LT	0.010	UGG	
	7.50							LT	0.010	UGG	
	8.00							LT	0.010	UGG	
	8.50							LT	0.010	UGG	
	9.00							LT	0.010	UGG	
	10.50							LT	0.010	UGG	
	6.00					TCLEE		LT	0.010	UGG	
	7.50							LT	0.010	UGG	
	8.00							LT	0.010	UGG	

EDSVEP SOIL CHEMICAL ANALYSES

Siteid	Depth	File Type	Samptech	Sampdate	Fieldid	Method	Testname	Bool	Corvalue	Units	Flagcode
	8.00							LT	0.010	UGG	
	8.50							LT	0.010	UGG	
	10.00							LT	0.010	UGG	
	5.00						12DCLP	LT	0.010	UGG	
	6.00							LT	0.010	UGG	
	7.50							LT	0.010	UGG	
	8.00							LT	0.010	UGG	
	8.50							LT	0.010	UGG	
	10.00							LT	0.010	UGG	
	5.00						135TMB	LT	0.010	UGG	
	6.00							LT	0.010	UGG	
	7.50							LT	0.010	UGG	
	8.00							LT	0.010	UGG	
	8.50							LT	0.010	UGG	
	10.00							LT	0.010	UGG	
	5.00						13DCLB	LT	0.010	UGG	
	6.00							LT	0.010	UGG	
	7.50							LT	0.010	UGG	
	8.00							LT	0.010	UGG	
	8.50							LT	0.010	UGG	
	10.00							LT	0.010	UGG	
	5.00						13DCLP	LT	0.010	UGG	
	6.00							LT	0.010	UGG	
	7.50							LT	0.010	UGG	
	8.00							LT	0.010	UGG	
	8.50							LT	0.010	UGG	
	10.00							LT	0.010	UGG	
	5.00						14DCLB	LT	0.010	UGG	
	6.00							LT	0.010	UGG	
	7.50							LT	0.010	UGG	
	8.00							LT	0.010	UGG	
	8.50							LT	0.010	UGG	
	10.00							LT	0.010	UGG	
	5.00						22DCLP	LT	0.010	UGG	
	6.00							LT	0.010	UGG	
	7.50							LT	0.010	UGG	
	8.00							LT	0.010	UGG	
	8.50							LT	0.010	UGG	
	10.00							LT	0.010	UGG	
	5.00						2CLT	LT	0.010	UGG	
	6.00							LT	0.010	UGG	
	7.50							LT	0.010	UGG	
	8.00							LT	0.010	UGG	
	8.50							LT	0.010	UGG	
	10.00							LT	0.010	UGG	
	5.00						3PT	LT	0.010	UGG	
	6.00							LT	0.010	UGG	
	7.50							LT	0.010	UGG	
	8.00							LT	0.010	UGG	
	8.50							LT	0.010	UGG	
	10.00							LT	0.010	UGG	
	5.00						4CLT	LT	0.010	UGG	
	6.00							LT	0.010	UGG	
	7.50							LT	0.010	UGG	
	8.00							LT	0.010	UGG	
	8.50							LT	0.010	UGG	
	10.00							LT	0.010	UGG	
	5.00						BCHPD	LT	0.010	UGG	
	6.00							LT	0.010	UGG	
	7.50							LT	0.010	UGG	
	8.00							LT	0.010	UGG	
	8.50							LT	0.010	UGG	
	10.00							LT	0.010	UGG	
	5.00						BRC6H5	LT	0.010	UGG	
	6.00							LT	0.010	UGG	
	7.50							LT	0.010	UGG	
	8.00							LT	0.010	UGG	
	8.50							LT	0.010	UGG	
	10.00							LT	0.010	UGG	
	5.00						BRCLM	LT	0.010	UGG	
	6.00							LT	0.010	UGG	
	7.50							LT	0.010	UGG	
	8.00							LT	0.010	UGG	
	8.50							LT	0.010	UGG	
	10.00							LT	0.010	UGG	
	5.00						BRDCLM	LT	0.010	UGG	
	6.00							LT	0.010	UGG	
	7.50							LT	0.010	UGG	
	8.00							LT	0.010	UGG	
	8.50							LT	0.010	UGG	
	10.00							LT	0.010	UGG	
	5.00						BUC6H5	LT	0.010	UGG	
	6.00							LT	0.010	UGG	
	7.50							LT	0.010	UGG	

EDSVEP SOIL CHEMICAL ANALYSES

Siteid	Depth	File Type	Samptech	Sampdate	Fieldid	Method	Testname	Bool	Corvalue	Units	Flagcode
	8.00							LT	0.010	UGG	
	8.50							LT	0.010	UGG	
	10.00							LT	0.010	UGG	
	5.00					C12DCE		LT	0.010	UGG	
	6.00							LT	0.010	UGG	
	7.50							LT	0.010	UGG	
	8.00							LT	0.010	UGG	
	8.50							LT	0.010	UGG	
	10.00							LT	0.010	UGG	
	5.00					C2H3CL		LT	0.010	UGG	
	6.00							LT	0.010	UGG	
	7.50							LT	0.010	UGG	
	8.00							LT	0.010	UGG	
	8.50							LT	0.010	UGG	
	10.00							LT	0.010	UGG	
	5.00					C2H5CL		LT	0.010	UGG	
	6.00							LT	0.010	UGG	
	7.50							LT	0.010	UGG	
	8.00							LT	0.010	UGG	
	8.50							LT	0.010	UGG	
	10.00							LT	0.010	UGG	
	5.00					C6H6		LT	0.010	UGG	
	6.00							LT	0.010	UGG	
	7.50							LT	0.010	UGG	
	8.00							LT	0.010	UGG	
	8.50							LT	0.010	UGG	
	10.00							LT	0.010	UGG	
	5.00					CCL2F2		LT	0.010	UGG	
	6.00							LT	0.010	UGG	
	7.50							LT	0.010	UGG	
	8.00							LT	0.010	UGG	
	8.50							LT	0.010	UGG	
	10.00							LT	0.010	UGG	
	5.00					CCL3F		LT	0.010	UGG	
	6.00							LT	0.010	UGG	
	7.50							LT	0.010	UGG	
	8.00							LT	0.010	UGG	
	8.50							LT	0.010	UGG	
	10.00							LT	0.010	UGG	
	5.00					CCL4		LT	0.010	UGG	
	6.00							LT	0.010	UGG	
	7.50							LT	0.010	UGG	
	8.00							LT	0.010	UGG	
	8.50							LT	0.010	UGG	
	10.00							LT	0.010	UGG	
	5.00					CH2CL2		LT	0.016	UGG	
	6.00							LT	0.010	UGG	
	7.50							LT	0.014	UGG	
	8.00							LT	0.010	UGG	
	8.50							LT	0.010	UGG	
	10.00							LT	0.010	UGG	
	5.00					CH3BR		LT	0.010	UGG	
	6.00							LT	0.010	UGG	
	7.50							LT	0.010	UGG	
	8.00							LT	0.010	UGG	
	8.50							LT	0.010	UGG	
	10.00							LT	0.010	UGG	
	5.00					CH3CL		LT	0.010	UGG	
	6.00							LT	0.010	UGG	
	7.50							LT	0.010	UGG	
	8.00							LT	0.010	UGG	
	8.50							LT	0.010	UGG	
	10.00							LT	0.010	UGG	
	5.00					CHBR3		LT	0.010	UGG	
	6.00							LT	0.010	UGG	
	7.50							LT	0.010	UGG	
	8.00							LT	0.010	UGG	
	8.50							LT	0.010	UGG	
	10.00							LT	0.010	UGG	
	5.00					CHCL3		LT	0.010	UGG	
	6.00							LT	0.010	UGG	
	7.50							LT	0.010	UGG	
	8.00							LT	0.010	UGG	
	8.50							LT	0.010	UGG	
	10.00							LT	0.010	UGG	
	5.00					CLC6H5		LT	0.010	UGG	
	6.00							LT	0.010	UGG	
	7.50							LT	0.010	UGG	
	8.00							LT	0.010	UGG	
	8.50							LT	0.010	UGG	
	10.00							LT	0.010	UGG	
	5.00					DBCP		LT	0.010	UGG	
	6.00							LT	0.010	UGG	
	7.50							LT	0.010	UGG	

EDSVEP SOIL CHEMICAL ANALYSES

Siteid	Depth	File Type	Samptech	Sampdate	Fieldid	Method	Testname	Bool	Corvalue	Units	Flagcode
	8.00							LT	0.010	UGG	
	8.50							LT	0.010	UGG	
	10.00							LT	0.010	UGG	
	5.00						DBRCLM	LT	0.010	UGG	
	6.00							LT	0.010	UGG	
	7.50							LT	0.010	UGG	
	8.00							LT	0.010	UGG	
	8.50							LT	0.010	UGG	
	10.00							LT	0.010	UGG	
	5.00						DBRM	LT	0.010	UGG	
	6.00							LT	0.010	UGG	
	7.50							LT	0.010	UGG	
	8.00							LT	0.010	UGG	
	8.50							LT	0.010	UGG	
	10.00							LT	0.010	UGG	
	5.00						DCPD	LT	0.010	UGG	
	6.00							LT	0.010	UGG	
	7.50							LT	0.010	UGG	
	8.00							LT	0.010	UGG	
	8.50							LT	0.010	UGG	
	10.00							LT	0.010	UGG	
	5.00						ETC6H5	LT	0.010	UGG	
	6.00							LT	0.010	UGG	
	7.50							LT	0.010	UGG	
	8.00							LT	0.010	UGG	
	8.50							LT	0.010	UGG	
	10.00							LT	0.010	UGG	
	5.00						HCBD	LT	0.010	UGG	
	6.00							LT	0.010	UGG	
	7.50							LT	0.010	UGG	
	8.00							LT	0.010	UGG	
	8.50							LT	0.010	UGG	
	10.00							LT	0.010	UGG	
	5.00						ISOPBZ	LT	0.010	UGG	
	6.00							LT	0.010	UGG	
	7.50							LT	0.010	UGG	
	8.00							LT	0.010	UGG	
	8.50							LT	0.010	UGG	
	10.00							LT	0.010	UGG	
	5.00						MEC6H5	LT	0.010	UGG	
	6.00							LT	0.010	UGG	
	7.50							LT	0.010	UGG	
	8.00							LT	0.010	UGG	
	8.50							LT	0.010	UGG	
	10.00							LT	0.010	UGG	
	5.00						NAP	LT	0.010	UGG	
	6.00							LT	0.010	UGG	
	7.50							LT	0.010	UGG	
	8.00							LT	0.010	UGG	
	8.50							LT	0.010	UGG	
	10.00							LT	0.010	UGG	
	5.00						PRC6H5	LT	0.010	UGG	
	6.00							LT	0.010	UGG	
	7.50							LT	0.010	UGG	
	8.00							LT	0.010	UGG	
	8.50							LT	0.010	UGG	
	10.00							LT	0.010	UGG	
	5.00						SBEN	LT	0.010	UGG	
	6.00							LT	0.010	UGG	
	7.50							LT	0.010	UGG	
	8.00							LT	0.010	UGG	
	8.50							LT	0.010	UGG	
	10.00							LT	0.010	UGG	
	5.00						STYR	LT	0.010	UGG	
	6.00							LT	0.010	UGG	
	7.50							LT	0.010	UGG	
	8.00							LT	0.010	UGG	
	8.50							LT	0.010	UGG	
	10.00							LT	0.010	UGG	
	5.00						T12DCE	LT	0.010	UGG	
	6.00							LT	0.010	UGG	
	7.50							LT	0.010	UGG	
	8.00							LT	0.010	UGG	
	8.50							LT	0.010	UGG	
	10.00							LT	0.010	UGG	
	5.00						TBBEN	LT	0.010	UGG	
	6.00							LT	0.010	UGG	
	7.50							LT	0.010	UGG	
	8.00							LT	0.010	UGG	
	8.50							LT	0.010	UGG	
	10.00							LT	0.010	UGG	
	5.00						TCLEA	LT	0.010	UGG	
	6.00							LT	0.010	UGG	
	7.50							LT	0.010	UGG	

EDSVEP SOIL CHEMICAL ANALYSES

Siteid	Depth	File Type	Samptech	Sampdate	Fieldid	Method	Testname	Bool	Corvalue	Units	Flagcode
	8.00							LT	0.010	UGG	
	8.50							LT	0.010	UGG	
	10.00							LT	0.010	UGG	
	5.00						TCLEE	LT	0.010	UGG	
	6.00							LT	0.010	UGG	
	7.50							LT	0.010	UGG	
	8.00							LT	0.010	UGG	
	8.50							LT	0.010	UGG	
	10.00							LT	0.010	UGG	
	5.00						TRCLE	LT	0.010	UGG	
	6.00							LT	0.010	UGG	
	7.50							LT	0.010	UGG	
	8.00							LT	0.010	UGG	
	8.50							LT	0.010	UGG	
	10.00							LT	0.010	UGG	
	5.00						XYLEN	LT	0.020	UGG	
	6.00							LT	0.020	UGG	
	7.50							LT	0.020	UGG	
	8.00							LT	0.020	UGG	
	8.50							LT	0.020	UGG	
	10.00							LT	0.020	UGG	
IV-1	5.50			04/17/92			111TCE	LT	0.010	UGG	
	7.00							LT	0.010	UGG	
	9.00							LT	0.010	UGG	
	5.50						112TCE	LT	0.010	UGG	
	7.00							LT	0.010	UGG	
	9.00							LT	0.010	UGG	
	5.50						11DCE	LT	0.010	UGG	
	7.00							LT	0.010	UGG	
	9.00							LT	0.010	UGG	
	5.50						11DCLC	LT	0.010	UGG	
	7.00							LT	0.010	UGG	
	9.00							LT	0.010	UGG	
	5.50						11DCPE	LT	0.010	UGG	
	7.00							LT	0.010	UGG	
	9.00							LT	0.010	UGG	
	5.50						123CPR	LT	0.010	UGG	
	7.00							LT	0.010	UGG	
	9.00							LT	0.010	UGG	
	5.50						123TCB	LT	0.010	UGG	
	7.00							LT	0.010	UGG	
	9.00							LT	0.010	UGG	
	5.50						124TCB	LT	0.010	UGG	
	7.00							LT	0.010	UGG	
	9.00							LT	0.010	UGG	
	5.50						124TMB	LT	0.010	UGG	
	7.00							LT	0.010	UGG	
	9.00							LT	0.010	UGG	
	5.50						12DBRE	LT	0.010	UGG	
	7.00							LT	0.010	UGG	
	9.00							LT	0.010	UGG	
	5.50						12DCLB	LT	0.010	UGG	
	7.00							LT	0.010	UGG	
	9.00							LT	0.010	UGG	
	5.50						12DCLE	LT	0.010	UGG	
	7.00							LT	0.010	UGG	
	9.00							LT	0.010	UGG	
	5.50						12DCLP	LT	0.010	UGG	
	7.00							LT	0.010	UGG	
	9.00							LT	0.010	UGG	
	5.50						135TMB	LT	0.010	UGG	
	7.00							LT	0.010	UGG	
	9.00							LT	0.010	UGG	
	5.50						13DCLB	LT	0.010	UGG	
	7.00							LT	0.010	UGG	
	9.00							LT	0.010	UGG	
	5.50						13DCLP	LT	0.010	UGG	
	7.00							LT	0.010	UGG	
	9.00							LT	0.010	UGG	
	5.50						14DCLB	LT	0.010	UGG	
	7.00							LT	0.010	UGG	
	9.00							LT	0.010	UGG	
	5.50						22DCLP	LT	0.010	UGG	
	7.00							LT	0.010	UGG	
	9.00							LT	0.010	UGG	
	5.50						2CLT	LT	0.010	UGG	
	7.00							LT	0.010	UGG	
	9.00							LT	0.010	UGG	
	5.50						3PT	LT	0.010	UGG	
	7.00							LT	0.010	UGG	
	9.00							LT	0.010	UGG	
	5.50						4CLT	LT	0.010	UGG	
	7.00							LT	0.010	UGG	
	9.00							LT	0.010	UGG	

EDSVEP SOIL CHEMICAL ANALYSES

Siteid	Depth	File Type	Samptech	Samprate	Fieldid	Method	Testname	Bool	Corvalue	Units	Flagcode
	5.50						BCHPD	LT	0.010	UGG	
	7.00							LT	0.010	UGG	
	9.00							LT	0.010	UGG	
	5.50						BRC6H5	LT	0.010	UGG	
	7.00							LT	0.010	UGG	
	9.00							LT	0.010	UGG	
	5.50						BRCLM	LT	0.010	UGG	
	7.00							LT	0.010	UGG	
	9.00							LT	0.010	UGG	
	5.50						BRDCLM	LT	0.010	UGG	
	7.00							LT	0.010	UGG	
	9.00							LT	0.010	UGG	
	5.50						BUC6H5	LT	0.010	UGG	
	7.00							LT	0.010	UGG	
	9.00							LT	0.010	UGG	
	5.50						C12DCE	LT	0.010	UGG	
	7.00							LT	0.010	UGG	
	9.00							LT	0.010	UGG	
	5.50						C2H3CL	LT	0.010	UGG	
	7.00							LT	0.010	UGG	
	9.00							LT	0.010	UGG	
	5.50						C2H5CL	LT	0.010	UGG	
	7.00							LT	0.010	UGG	
	9.00							LT	0.010	UGG	
	5.50						C6H6	LT	0.010	UGG	
	7.00							LT	0.010	UGG	
	9.00							LT	0.010	UGG	
	5.50						CCL2F2	LT	0.010	UGG	
	7.00							LT	0.010	UGG	
	9.00							LT	0.010	UGG	
	5.50						CCL3F	LT	0.010	UGG	
	7.00							LT	0.010	UGG	
	9.00							LT	0.010	UGG	
	5.50						CCL4	LT	0.010	UGG	
	7.00							LT	0.010	UGG	
	9.00							LT	0.010	UGG	
	5.50						CH2CL2	LT	0.010	UGG	
	7.00							LT	0.010	UGG	
	9.00							LT	0.010	UGG	
	5.50						CH3BR	LT	0.010	UGG	
	7.00							LT	0.010	UGG	
	9.00							LT	0.010	UGG	
	5.50						CH3CL	LT	0.010	UGG	
	7.00							LT	0.010	UGG	
	9.00							LT	0.010	UGG	
	5.50						CHBR3	LT	0.010	UGG	
	7.00							LT	0.010	UGG	
	9.00							LT	0.010	UGG	
	5.50						CHCL3	LT	0.010	UGG	
	7.00							LT	0.010	UGG	
	9.00							LT	0.010	UGG	
	5.50						CLC6H5	LT	0.010	UGG	
	7.00							LT	0.010	UGG	
	9.00							LT	0.010	UGG	
	5.50						DBCP	LT	0.010	UGG	
	7.00							LT	0.010	UGG	
	9.00							LT	0.010	UGG	
	5.50						DBRCLM	LT	0.010	UGG	
	7.00							LT	0.010	UGG	
	9.00							LT	0.010	UGG	
	5.50						DBRM	LT	0.010	UGG	
	7.00							LT	0.010	UGG	
	9.00							LT	0.010	UGG	
	5.50						DCPD	LT	0.010	UGG	
	7.00							LT	0.010	UGG	
	9.00							LT	0.010	UGG	
	5.50						ETC6H5	LT	0.010	UGG	
	7.00							LT	0.010	UGG	
	9.00							LT	0.010	UGG	
	5.50						HCBD	LT	0.010	UGG	
	7.00							LT	0.010	UGG	
	9.00							LT	0.010	UGG	
	5.50						ISOPBZ	LT	0.010	UGG	
	7.00							LT	0.010	UGG	
	9.00							LT	0.010	UGG	
	5.50						MEC6H5	LT	0.010	UGG	
	7.00							LT	0.010	UGG	
	9.00							LT	0.010	UGG	
	5.50						NAP	LT	0.010	UGG	
	7.00							LT	0.010	UGG	
	9.00							LT	0.010	UGG	
	5.50						PRC6H5	LT	0.010	UGG	
	7.00							LT	0.010	UGG	
	9.00							LT	0.010	UGG	

EDSVEP SOIL CHEMICAL ANALYSES

Siteid	Depth	File Type	Samptech	Sampdate	Fieldid	Method	Testname	Bool	Corvalue	Units	Flagcode
	5.50						SBBEN	LT	0.010	UGG	
	7.00						LT	0.010	UGG		
	9.00						LT	0.010	UGG		
	5.50						STYR	LT	0.010	UGG	
	7.00						LT	0.010	UGG		
	9.00						LT	0.010	UGG		
	5.50						T12DCE	LT	0.010	UGG	
	7.00						LT	0.010	UGG		
	9.00						LT	0.010	UGG		
	5.50						TBBEN	LT	0.010	UGG	
	7.00						LT	0.010	UGG		
	9.00						LT	0.010	UGG		
	5.50						TCLEA	LT	0.010	UGG	
	7.00						LT	0.010	UGG		
	9.00						LT	0.010	UGG		
	5.50						TCLEE	LT	0.010	UGG	
	7.00						LT	0.010	UGG		
	9.00						LT	0.010	UGG		
	5.50						TRCLE	LT	0.010	UGG	
	7.00						LT	0.010	UGG		
	9.00						LT	0.010	UGG		
	5.50						XYLEN	LT	0.020	UGG	
	7.00						LT	0.020	UGG		
	9.00						LT	0.020	UGG		

Table 4-3: EDSVEP Tracer Test Data

Data Set (date)	Injection		Total Extraction		EV-1		EV-2		EV-3		EV-4		Summed Extraction		Pressure	
	Flow Rate (scfm)	Recovery (%)	Flow Rate (scfm)	Recovery (%)	Flow Rate (scfm)	Recovery (%)	Flow Rate (scfm)	Recovery (%)	Flow Rate (scfm)	Recovery (%)	Flow Rate (scfm)	Recovery (%)	Flow Rate (scfm)	Recovery (%)	SP-3 ("H ₂ O)	SP-15 ("H ₂ O)
72092b	4	70	21.7	70	5.7	18.1	7.9	19	4.78	22.9	3	9.7	21.38	70	-1	
72192b	4.7	96	21.2	96	5.6	26.6	6.4	19.3	4.7	31.5	3.6	19.1	20.3	97		
72192c	10.4	111	22.4	112	5.6	27.9	5.9	19.4	4.7	34	4.2	35.1	20.4	116	-0.01	
72292a	12	109	22.8	95	4.8	19	6.4	19.6	4.8	25.1	4.3	23.2	20.3	87		
72392b	4.2	129	18.8	124	4.7	24.7	5.9	30	4.6	45.5	3.3	20	18.5	120	-0.2	
72392c	11.4	123	17.5	104	3.7	17.6	6.5	30.7	4.9	33.5	3.3	23.7	18.4	106	0.5	
72392d	14.9	115	17.5	88	4.1	18.2	5.3	23	4.9	26.5	3.3	20.1	17.6	88	1.2	
72492a	5.2	111	14.7	74	3.9	18.1	4.6	17.3	4.6	34.5	3.2	19.9	16.3	90		
72492b	15.9	108	11.9	47	3.5	20	4.6	23	2.4	15	2.4	15	12.9	73		
72492c	5.8	96	13.8	72	3.3	19.6	4.6	21.1	3.3	26.4	3.3	31.8	14.5	99		
72792a	14	84	15.1	71	3.3	19.4	2.5	12.9	4.1	27.7	3.3	22.5	13.2	83		
72892a	14.7	106	16.6	65	4.1	18.4	8.1	26.4	4.2	25.3	4.2	26.8	20.6	97	1	
72892b	7.1	94	15.2	73	4.1	23.8	6.3	21.4	3.3	27.2	3.3	30.9	17	103		
72892c	6.8	103	13.8	84	3.4	25.5	3.8	20.6	3.1	32.7	2.2	24.3	12.5	103	0.15	
72992a	5.5	92	17	75	4.4	22.4	3.2	11.9	4.3	31.5	3.6	21.7	15.5	88	0.095	
73092a	6	106	17	92	4.3	24.2	5.3	20.2	4.5	31	3.6	23.5	17.7	99		
73092b	6.6	102	17	89	4.3	24.3	5.5	21.4	3.7	27	3.3	20.6	16.8	93	1	
82092a	6.2	91	18.1	35	4.6	9.2	4.9	8.3	4.4	16.6	3.8	9	17.7	43	1.15	
82092b	4.2	87	18.4	63	4.4	13.9	4.9	11.9	4.4	23.8	3.6	11.8	17.3	61	0.33	
100792a	20.5	107	21	58	5	13.8	5.8	15.6	6.2	18.4	4.9	13	21.9	61	3.5	
100892a	20.5	97	17.1	56	3.6	12.1	6.5	19.2	4.3	15.2	3.3	11.1	17.7	58	5	
100992a	20.2	107	15.9	59	4.4	16.3	5.9	19.8	4	15.7	3.8	14.1	18.1	66	5.1	
100992b	20.2	102	15.9	61	4.4	17.5	5.9	21	4	16.1	3.8	15.6	18.1	70		
100992c	20	102	15.7	69	3.7	16.2	3.4	14.7	4	18.5	3.8	18.2	14.9	68		
101292a	20.3	107	23.2	106	4.5	20.7	7	31	5.4	25.6	4.2	20.8	21.1	98	-0.05	-0.45
101492a	19.9	99	20.6	73	4.6	15.8	6.5	21.1	4.6	15.6	4.6	15.9	20.3	68	-0.03	-0.47
102792b	4.9	96	16.5	98	4.6	20.4	3.6	18	5.2	41.7	4	20.1	17.4	100		
102892a	5	102	20.6	100	4	15.6	6.6	30.4	5.1	33.4	4.2	17.4	19.9	97		
102892b	6.7	95	19.3	90	4.3	17.7	6.3	27.8	5.1	5.1	4.2		19.9	0		
102892c	6.9	85	19.3	97	4.3	18.8	6.3	29.5	5.1	26.9	4.2	16.6	19.9	89	0.61	-0.4
102892d	6.9	92	19.3	92	4.3	18.8	6.3	29.5	5.1	28.2	4.2	16.9	19.9	93	0.61	-0.4
102892e	9.8	100	20.5	92	4.2	16.8	5.8	25.6	4.8	24.7	4.3	17.7	19.1	85	1.87	-0.23
102992a	10.3	104	19	95	3.8	16.9	7.2	35	4.3	25.2	3.4	16.3	18.7	93	2.15	-0.2
102992b	14.7	101	20	93	4.4	20.1	5.5	24.3	4.8	24.1	4.2	20.9	18.9	89	3.75	0.05
102992c	11.1	103	25	111	5.3	21	8	32.8	6.3	32.2	4.7	18.6	24.3	105	1.8	-0.35

Table 5-1. EDSVEP Cost Model Spreadsheet

Soil Characteristics		Treatment Summary		WELL INSTALLATION COST SUMMARY			
Soil % water	10	Treat Zone Thickness (ft)	10	Heater well Cost	1800		
Soil Density (Tons/yd ³)	1.2	Heating Efficiency	0.5	Extract well Cost	475		
Soil Permeability (Darcy)	2	Heating Time(days)	109	Heater wells Total (k\$)	63		
Contamination (ppm)	1000	Cooling Time(days)	11	Extr. Wells Total (k\$)	27		
Min. Energy Req.(Kwh/Ton)	141	Htr. Peak Power Req'd (kW)	420	Subtotal (k\$)	26		
		Avg. Htr. Power Output Pct.	80%	AUXILIARY SYSTEM COST SUMMARY			
Site Characteristics		Avg. Htr. Power Req'd (kW)	336	Power Supply System	50000		
Total Length (Ft)	100	Power Req'd for Others (kW)	107	Controller Cost Per Htr	500		
Total Width (Ft)	70	On-Stream Factor	0.85	Piping & Flow Control	59550		
Well Spacing (Ft)	10	Treatment Tonnage per Site	3111	Subtotal (k\$)	100		
No. of Heater Wells/Row	5	No. of Sites Treated/yr	2.6	GAS TREATMENT COST SUMMARY			
No. of Extract Wells/Row	6	Treatment Rate (Ton/day)	25.9	Purchased Equipment Costs			
Total # of Heater Wells	35	Treatment Rate (Ton/yr)	9040	Injection Air Blower	12000		
Total # of Extract Wells	48			Vacuum System	68000		
		Gas Treatment System		Wet Scrubber System	32000		
		Air Flow/Htr. well (scfm)	20.0	Condensate Tank & Pumps	4000		
Heater Well Assembly		Total Inj. Air Flow (scfm)	700	Carbon Adsorbers	68000		
Well Depth (Ft)	12.5	Blower Discharge Pres(PSIA)	19.7	Subtotal (k\$)	154		
Well Diameter (In)	4	VcPump Discharge Pres(PSIA)	14.7	Total Installed Cost(k\$)	276		
Heater Length (ft)	12	Extract Well Pres(PSIA)	11	TOTAL CAPITAL COST (k\$)			
Screen Length (ft)	6	Gas Flow/Ext. Well (scfm)	26.0	30% Contingency +			
Power Supply (W/Ft)	1000	Total Gas Flow (scfm)	1248	GENERAL FACILITY (25%)			
# of Heaters per Well	1	Water Vapor Flow (scfm)	76	150			
Heaters in Use	1	Water Vapor Flow (lb/hr)	215	ASSUMPTIONS			
Total Power per Well (kW)	12	Total Air Flow (scfm)	1172	# of Operators req'd	0.33		
Mat 1 of Construction	S.S.	Total Air Flow (lb/hr)	5382	Analytical Cost (k\$/yr)	100		
		Air Cooler Outlet T (F)	90	Clean-Up Cost(\$/well)	500		
Extract Well Assembly		Moisture % in Outlet Gas	6.1%	Electricity Cost(\$/kwh)	0.06		
Well Depth (Ft)	12.5	Outlet Gas Flow (scfm)	1248	Cond. Disposal(\$/gal)	0.25		
Well Diameter (In)	2	Condensate Flow (gpd)	10	OPERATING COST SUMMARY			
Screen Length (ft)	6	Condensate Stor. Tank(gal)	500				
Mat 1 of Construction	C.S.	Total Contaminants (lb/day)	51.8	k\$/site	k\$/yr	\$/Ton	%
		Air Cooler Duty (KBtu/hr)	87	Electricity	71	184	22.9
		Contaminant in Gas (ppm) ++	401	Direct Labor	46	120	14.9
		Contaminant in Liq (lb/day)	0.0	Maintenance(20% of CC)	46	120	14.9
		Fixed Bed Carbon Charge(lb)	2600	Analytical	39	100	12.4
		Carbon Bed Diameter (ft)	6	Site Clean-Up	42	107	13.3
				Condensate Disposal	0.3	1	0.1%
				Subtotal	245	632	78.6
				Capital Charges -			
				100% for Wells	112	289	35.9
				25%/yr for Skid/Other	47	122	15.2
				25%/yr for Gen. Facil	15	38	4.7
				Subtotal	174	449	55.8
				Total	418	1081	134

++ Vapor pressure same as n-undecane