

19960705 066

The *Air Force Journal of Logistics*
is now available on the World Wide Web
at this address:

<http://www.hq.af.mil/AFLG/AFLMA/afjl/afjlhome.html>

WINTER
1996

AIR FORCE JOURNAL *of* LOGISTICS

United States—Republic of China

A CLASH OF CULTURES



DISTRIBUTION STATEMENT A
Approved for public release;
Distribution Unlimited

DTIC QUALITY INSPECTED 1

AFRP
25-1

VOL XX
NO. 1

AIR FORCE JOURNAL ^{of} LOGISTICS

CONTENTS

WINTER
1996

ARTICLES

- 1 **Logistics in the Republic of China—A Clash of Cultures**
Richard A. Romer, CPL
- 7 **Logistics Career Broadening Program: A Personal Perspective**
Captain Rob Roberts, USAF
- 8 **Virtual Prototyping for Logistics With Low-End 3D Graphics Programs**
James C. Schaaf, Jr.
Curtis W. Walker, CPL
- 14 **Individual Mobilization Augmentees in Logistics**
Captain Stella T. Smith, USAF
Captain Mark A. Gray, USAF
Captain Mark A. Abramson, USAF
- 18 **Pollution Prevention: Planning to Save**
Cathy Andrews
- 20 **Reutilization—A Logstician's First Source of Supply**
Joe Murphy
- 22 **Those Oh So Vulnerable Lines of Communication**
Lieutenant Bart A. Vinskey, SC, USN
- 24 **Systematic Readiness Engineering Analysis: Converting Modern Mythology Into Future Reality**
William Jones, Jr.
Deborah S. Motz
- 36 **Containerization Adds Flexibility for Military Deployments**
Danita L. Hunter

DEPARTMENTS

- | | | | |
|----|---|----|-------------------------|
| 5 | <i>Career and Personnel Information</i> | 34 | <i>Current Research</i> |
| 17 | <i>USAF Logistics Policy Insight</i> | 39 | <i>Inside Logistics</i> |
| 21 | <i>Environmental News</i> | | |



Honorable Sheila E. Widnall
Secretary of the Air Force

Ronald L. Orr
Director, Logistics Plans, Programs and
Integration
HQ USAF

Colonel Clarence T. Lowry
Commander
Air Force Logistics Management Agency

Editors

Lieutenant Colonel Bruce A. Newell
Senior Master Sergeant Manley F. Adams
Air Force Logistics Management Agency

- Purpose** The *Air Force Journal of Logistics* provides an open forum for the presentation of issues, ideas, research, and information of concern to logisticians who plan, acquire, maintain, supply, transport, and provide supporting engineering and services for military aerospace forces. It is a non-directive, quarterly periodical published under AFI 37-160V4. Views expressed in the articles are those of the author and do not necessarily represent the established policy of the Department of Defense, the Department of the Air Force, the Air Force Logistics Management Agency, or the organization where the author works.
- Approval Statement** The Secretary of the Air Force has determined that the publication of this periodical is necessary in the transaction of the public business as required by law of the Department. Use of funds for printing this publication has been approved by the Secretary of the Air Force, 17 July 1986, in accordance with AFI 37-160V4.
- Distribution** Distribution within the Air Force is F. Customers should establish requirements through the PDO system on the basis of 1 copy for every 5 logistics officers, top three NCOs, and professional level civilians assigned. If unable to use the PDO system, contact the editor. The *AFJL* is now available on the World Wide Web: <http://www.hq.af.mil/AFLG/AFLMA/afjl/afjlhome.html>. The *AFJL* is also for sale by the Superintendent of Documents, U.S. Government Printing Office, Washington, D.C. 20402. Back issues are stocked at AFLMA/LGJ. Articles in this edition may be reproduced in whole or in part without permission. If reproduced, the *Air Force Journal of Logistics* requests a courtesy line.
- Manuscripts** Manuscripts are welcome from any source desiring to deepen or broaden the knowledge and understanding of Air Force logistics professionals. They should be typed (double-spaced) and be between 1500-3500 words. Figures, graphics, and tables (separate pages) should be numbered consecutively within text. Author may send a diskette (ASCII file) along with the hard copy of the article (Address: AFLMA/LGJ, 501 Ward Street, Building 205, Maxwell AFB, Gunter Annex AL 36114-3236; DSN 596-4087, Commercial (334) 416-4087). Articles may also be electronically submitted via Internet. Call for specific instructions.
- Refereeing** *AFJL* is a refereed journal. Manuscripts are subject to expert and peer review, internally and externally, to ensure technical competence, correct reflection of stated policy, and proper regard for security.

Logistics in the Republic of China—A Clash of Cultures

Richard A. Romer, CPL

The United States has been the historic weapons supplier to the Republic of China (ROC) on Taiwan. In 1979, the US transferred diplomatic recognition to the mainland People's Republic of China (PRC). In 1984, the ROC government decided to design an Indigenous Defensive Fighter (IDF). The ROC gave responsibility for the IDF program to its Aero Industry Development Center (AIDC) in Taichung. AIDC contracted with General Dynamics' Fort Worth Division to advise them. AIDC produced four prototype IDFs for combined Development Test and Evaluation/Initial Operational Test and Evaluation programs. Although the integrated logistics support program of the IDF took the form of a US effort, significant differences in the Chinese culture altered the conduct of the program and the outcome. This paper documents these differences and details how they resulted in unintended consequences. It highlights the hazards of adopting policies and procedures without adaptation to the environment.

Introduction

Since the expulsion of its government from the Chinese mainland to the island of Taiwan in 1949, the Republic of China depended on the United States as its protector and supplier of arms and weapon systems. The US pursued a policy of equipping the ROC to defend itself against an invasion by the People's Republic of China ninety miles to the west across the straits of Taiwan. The US was careful, however, not to permit the ROC to achieve the offensive capability to invade the mainland and attack the PRC.

During the 1950s, '60s, and '70s, the ROC became almost totally dependent upon the US for its weapon systems, follow-on support, acquisition logistics, and program management. In 1972, United States President Richard M. Nixon changed that historic alliance when he opened relations with the PRC by making a dramatic journey to Beijing to hold an internationally televised meeting with the PRC's leader, Communist Party Chairman Mao Tse-tung. The US/ROC relationship was permanently altered in 1979 when President Jimmy Carter announced a "One China" policy. The US withdrew diplomatic recognition from the ROC and vested it in the PRC. Friends of the ROC in the US Congress insisted on the protection of a separate ROC by passing the Taiwan Relations Act which committed the US to maintain the 1979 "status quo" military balance between the ROC and the PRC.

ROC Air Force Modernization

In 1979, the ROC was already shopping for new fighter aircraft for its air force. Their Lockheed F-104G/F "Starfighters" and Northrop F-5E/F "Tiger II" aircraft were both ageing and being obsolesced by the modernization taking place across the Taiwan Straits in the PRC. At the time of President Carter's announcement, a ROC selection team was physically in the US conducting a

comparative evaluation of General Dynamics' F-16, McDonnell-Douglas' F/A-18, and Northrop's F-20 aircraft. The ROC government was preparing a Foreign Military Sales request for submission to the US. The change in US/ROC relationship ended any consideration of an aircraft sale.

For the next five years, the ROC attempted in vain to find an aircraft supplier anywhere in the world. In that period, no country was willing to incur the wrath of the PRC by selling modern fighter aircraft to the ROC. In 1984, a frustrated ROC government decided to design, develop, produce, and deploy an Indigenous Defensive Fighter (IDF). The ROC legislature gave the project the highest national priority, but they articulated an additional agenda—the IDF program was to be the vehicle for bringing technology transfer to Taiwan. The ROC approached the US State Department, not the Department of Defense, with the IDF program and received approval to contact US aerospace companies for assistance on a commercial, not a military, basis. A search of interested US companies was conducted, and General Dynamics' Fort Worth Division was selected for award of a commercial contract to advise the ROC developer.

The Indigenous Defensive Fighter Program

The IDF aircraft was named the CK-1 after the third President of the ROC, Chiang Ching-kuo, son of Generalissimo (and second President) Chiang Kai-shek. Designed as a light-weight fighter with limited range, it provided the ROC defensive capability without having the range to be an offensive threat to the PRC. It had twin engines and an internal 20mm Gatling gun as well as weapons stations for ROC-developed infrared and radar homing missiles, the TC-1 and TC-2 "Sky Arrow" missiles. It incorporated the technology of the 1980s with a two-channel digital fly-by-wire flight control system, side stick controller, "glass cockpit" integrated displays system, and electronic engine controls.

Program responsibility for the IDF was assigned to the Aero Industry Development Center (AIDC) in Taichung, a government activity populated by military personnel and government employed civilians. AIDC reported to the Ministry of National Defence through the Chung Shan Institute of Science and Technology (CSIST) in Taoyuan. AIDC had originally been established as the factory for coproduction of the Northrop F-5 aircraft on the site of the Ching Chuan Kang (CCK) Air Base which the United States Air Force used as a base during the Vietnam War. Although the ultimate customer for the IDF was the ROC Air Force, AIDC maintained a separate and direct reporting channel to the Ministry of National Defence and resisted all attempts by the ROC Air Force to become involved in the program.

The original IDF program called for the construction of four prototype test aircraft, three single-seat and one two-seat, for the

conduct of a joint Development Test & Evaluation/Initial Operational Test and Evaluation. Ten preproduction aircraft would then be constructed for Follow-on Operational Test & Evaluation and the training of an initial cadre of ROC Air Force instructor pilots. A total of 240 production aircraft were to be produced to equip four fighter wings. An improved performance engine was to be procured and introduced with the second 120 aircraft and possibly retrofitted to the first 120. Many of the aircraft and avionics subsystems were developed specifically for the IDF. The technology transfer program brought coproduction or coassembly of many of the subsystems to the ROC, particularly the propulsion and avionics.

US Subsystem Suppliers

A number of US companies were contracted by AIDC to provide subsystems and components. Allied Signal Aerospace supplied the propulsion, secondary power, and integrated displays subsystems. Martin-Baker provided the egress system and Lear Astronics provided the flight control computer and side stick controller. Litton was contracted for two Electronic Warfare suites; Tracor, the Defensive Countermeasures set; and Moog, flight control actuators. General Electric produced the 20mm Gatling gun and developed an air-to-air radar for the IDF which was based on its original design for the F-20 radar.

General Dynamics' Fort Worth Division was the contractor for the flight control system as well as the overall advisor to AIDC for the IDF program. The advisory work force grew to as many as 150 advisors in Taiwan with an additional 50 working in Fort Worth. The disciplines included engineering, design, structural integrity, logistics, flight test, operational test and evaluation, manufacturing, propulsion, reliability, purchasing, and program management. In addition, the US subsystem suppliers established work forces and advisors on-site in Taiwan. AIDC established an office in Fort Worth which often had as many as 50 people assigned.

The contracting with the US suppliers was conducted by an AIDC branch office established in leased facilities in Fort Worth, Texas. They conducted most of their contract administration from Fort Worth which made oversight of the dispersed suppliers difficult.

IDF Program Phases

Instead of the traditional five program phases which define US programs, the ROC program used two: Full Scale Development (FSD) and Production. This shortcut was based on their incorrect assumption that development risk was low and that the subsystems would be delivered to Taiwan ready for installation. This approach minimized the need for system integration. In addition, responsibility for the FSD phase of each subsystem was assigned to the Chung Shan Institute of Technology (CSIST), while production of everything but the TC-1 and TC-2 missiles was the responsibility of AIDC.

In contracting with the suppliers of the FSD subsystems, CSIST failed to include front-end integrated logistics support (ILS). The FSD systems which CSIST then transitioned to AIDC for production were, therefore, delivered without technical data, spares, support equipment, maintenance procedures, and the remainder of US standard ILS packages. Reputable US suppliers

which had developed sophisticated ILS planning methodologies in response to demands from their US customers took advantage of the ROC negotiators. They offered the ROC front-end savings generated by eliminating front end ILS. It was only later that the ROC Air Force discovered that dramatically higher life-cycle costs had been embedded.

The Impact of Ghosts

A fundamental belief in ghosts is embedded in the Chinese culture. This is independent of any ancient or modern religious belief: Buddhist, Confucian, Christian, etc., and has not been influenced by religion. The eighth month of the Chinese calendar is "Ghost Month" when the ghosts of the dead return to earth to visit their living relatives. Marriages are not scheduled during Ghost Month and births are avoided if at all possible. The opening of a badly needed hospital wing in the city of Taipei was delayed until after the end of Ghost Month rather than risk the possibility of a ghost taking up residence. The last day of Ghost Month is marked by the erection of shrines in front of every house and business on which fresh fruits and sweets are set out for the ghosts to take back with them to the nether worlds. When someone dies, money is folded and burned to send to the ghost in Heaven to provide him/her with needed cash. When a close relative dies, the survivors are precluded from visiting the homes of friends lest the ghost of the departed remain behind. If this occurs, an exorcism is required. In the ROC, ghosts play a significant role in weapon system development as you will see a little later in this article.

Face is Everything

In the Chinese culture, the psychological or physical loss of face is the worst of all possible outcomes. For one person to cause another to lose face is undesirable since that invites retribution at some later time. The original person wants to avoid a loss of face at all costs. As a consequence, perfect performance is expected the first time anything is done, and one is reluctant to point out any lack of perfection since that would cause a loss of face. Taking risks implies the possibility of failure and the resultant loss of face, and, therefore, risk is avoided at all costs. Decisions are deferred as long as possible since making no decision is less risky than making one which might be wrong and incur a resultant loss of face.

In the US, weapon system testing is performed to identify deficiencies early when their correction is comparatively inexpensive and has minimal impact on cost and schedule while improving performance and supportability. It can be argued that we sometimes go overboard on identifying deficiencies and that this information has been misused by the opponents of some systems to attack those systems.

Conversely, in China, testing is conducted to validate the perfection of a design. The identification of deficiencies needing correction causes a loss of face by the individual or team which did not perform perfectly the first time. During stability and control testing on the IDF, the program manager was reluctant to authorize a high angle of attack test flight. He was concerned that the aircraft might depart controlled flight and enter a spin requiring deployment of the spin recovery parachute which had been installed and successfully tested. This would be a very

public admission that the aircraft design was less than perfect since the aircraft would spin, thereby causing a loss of face. The program manager in this case was experienced, trained, and educated and held a PhD in aeronautical engineering from a major US university. Unfortunately, his cultural foundation overruled logic and education.

Failure reporting and corrective action were almost impossible to deal with for the same reasons, making reliability growth unachievable. Dealing with failure information was an admission of the imperfection of the system, subsystem, or component. The engineering community responsible for reporting on reliability growth spent most of its time reanalyzing failure data, attempting to improve the statistics rather than improving the reliability of the aircraft, its systems, and components. Finding rationale to declare failures "nonrelevant" to exclude them from the reliability calculations became a way of improving the numerical result. Unfortunately, the low reliability of the aircraft remained constant since redesign and corrective action were not occurring.

In the US, accident and mishap investigation and reporting processes are designed to reveal the cause or causes if at all possible. The system has an almost religious integrity so that corrective action can be taken to prevent a recurrence. The investigators are selected from a pool of people not involved with the mishap or the organization to remove any temptation to cover up. Individuals are protected from punishment for their testimony to a mishap investigation board to encourage them to tell the truth. Accident investigation proceedings are sealed to protect testimony and evidence.

Accident investigation in China is designed to prevent a loss of face of those who might be responsible. The members of a mishap board are the senior officials of the organizations and activities which might have contributed to the mishap. Testimony is taken with the senior members of the hierarchy present which inhibits the presentation of anything but covering up. The result is normally a finding of pilot error or act of God. Unfortunately embedded flaws remain unidentified and are usually uncorrected.

Priorities in the Chinese Culture

The Chinese culture is unique in the way priorities are established. The first priority on anyone's agenda is himself or herself. The second is the immediate family, followed by the extended family, the home village on Taiwan, the ancestral home on the Chinese mainland, the Chinese people, the nation, one's military Service, one's unit of assignment, one's office, and finally the program on which one is working. If one is going to motivate a team of people to achieve a common goal, it becomes necessary to find a way to link the desired outcome with the personal agenda of every person involved. The more complex the enterprise, and the more work units involved in achieving the desired outcome, the more difficult it becomes to achieve this convergence. An aircraft development is a complex enterprise involving the efforts of thousands of people assigned to dozens of offices and organizations.

This differs from the Japanese, and the Americans, where a careful and deliberate building of consensus frequently results in the subordination of personal agendas to the achievement of a common goal or outcome.

An IDF Crashes

During a test flight in July, 1991, one of the prototype IDF test aircraft departed controlled flight and crashed into the waters of the Straits of Taiwan. Although the test pilot successfully ejected from the aircraft, he was badly injured. When a fishing trawler arrived on the scene 15 minutes after the accident to recover the pilot, he had already drowned. The aircraft broke up on impacting the water, and, although a search was conducted for several weeks, no physical evidence was ever recovered.

Two days after the accident, an investigator from the egress system manufacturer, Martin-Baker, sought to find the pilot's flight suit to examine it for harness chaffing. After several days of frustration, he learned that another test pilot had burned the flight suit, one of the few pieces of physical evidence recovered from the mishap. The pilot was not trying to destroy evidence, but was sending the departed pilot in Heaven his favorite flight suit to appease his ghost so he could fly the test aircraft there.

The mishap investigation board was comprised of the chiefs of the sections most directly involved in the design of the aircraft, its preparation, or the conduct of the flight. They were the people who had the most face to lose by the revelation of any mishap causes in their areas of responsibility. The integrity of the investigation process was compromised at the outset.

The official cause of the accident announced by the investigation board was the unaccustomed wind encountered by the aircraft that day and time at that particular altitude. Of course, there is now a hole in the IDF flight envelope and no one deliberately flies at that altitude and airspeed. No design or manufacturing process flaws were identified or corrected, and no inspections of other IDF aircraft were introduced. On the other hand, the mishap test pilot was honored with a posthumous promotion to General. A larger than life statue of the pilot was erected in front of the flight test operations building at the first opportunity for a public ceremony. The bad news is that the remaining test aircraft, and all those built since, are flying with the same embedded design, manufacturing, and maintenance process flaws which caused the mishap aircraft to crash.

Business Ethics

International programs come with the embedded business ethics of the culture in which they are taking place. Although the IDF program was offered a proven air-to-air radar, a manufacturer was selected who lacked a developed system. The radar quickly manifested the problems familiar with such a development and already solved by the rejected vendor. Within a year from contract award, the radar vendor was in a cost overrun mode; they had fallen behind the contract schedule, and the radar's performance was below the specification. This was particularly critical since the radar was essential to the functioning of the aircraft as a weapon system and the development of the two indigenous air-to-air missiles.

Although one of the two US military jet engine manufacturers already had an engine design which met the IDF system requirements, the IDF selected a US commercial engine manufacturer which had to develop an engine. The selected company and the aircraft developer, AIDC, formed a joint venture company to produce the engine. The AIDC commander and IDF

program manager were "elected" to the Board of Directors of the joint venture company. It quickly became impolitic and then unwise for anyone on the IDF program, Chinese or American, to identify the many deficiencies of the engine even though it was underpowered, unmaintainable, and had a limited airstart envelope.

The relationships established with each of the selected vendors were all clouded by similar concerns, controversies, and conflicts of interest. One would go to meetings to discuss identified deficiencies and recommend corrective actions and later be chastised for causing others to lose face. The needed system capability and satisfaction of customer requirements were ignored in the process. The incentive was to manipulate the process via the back door.

Change is Glacial

In a culture where risk is avoided, change occurs at a glacial pace. The aircraft developer purchased a computer-based analytical tool for the conduct of Logistics Support Analysis. They spent a lot of time conducting a front-end analysis and generating recommendations. The analysis provided a number of sound recommendations for maintenance, sparing, support equipment, and level of repair. When anything unusual or evolutionary was suggested, however, it was rejected by the ROC Air Force since it recommended a change from the way things were done with the F-104 or F-5 systems.

The propulsion system for the IDF was designed for modularity using an on-condition maintenance philosophy at a significant premium in cost. The ROC Air Force chose to manage and maintain the engine as an overhauled whole engine since that was the traditional method.

Modern avionics have permitted air forces to transition from three levels of maintenance to two, but the IDF is being maintained using three levels since that is the accustomed way.

Test and Evaluation

In the US, development testing is performed by the developer comparing the early product against the specification to identify deficiencies needing correction. In the ROC, as stated earlier, development testing is performed to validate the perfection of the design. The process is undisciplined and the identification of deficiencies is avoided at all costs since doing so causes the loss of face.

In the US, operational testing is performed by the intended user who compares the product against the stated requirement. The objective is to evaluate the effectiveness and suitability of the system to assist in program decisions. In the ROC, operational testing is a random process which serves the personal agenda of those performing the testing. Although logistics suitability testing was conducted on the IDF, it had virtually no impact since a credible Failure Reporting and Corrective Action System was lacking.

Information is Power

The weapon system development process is information intensive. Success depends on open access to, and unrestricted flow of, data. The sharing of information across disciplines is essential for progress. Flight test data is needed by design,

engineering, logistics, safety, structures, and a number of other disciplines whose system or subsystem is being tested.

In the Chinese culture, information is power and protecting it is paramount. The technology is available to construct Local Area Networks (LANs) and Wide Area Networks (WANs). They generally do not exist, or if they do, they are not used. Everyone keeps a personal record since that best serves individual agendas. When a problem arises, rather than using existing records or data systems or existing analysis techniques, new collection systems are created. It is easier to manipulate data than to improve a product.

The IDF Program Today

In July, 1992, under pressure to win the state of Texas in the November presidential election, George Bush agreed to sell 150 F-16 aircraft to the ROC. The strategy worked for Bush in Texas. In August, 1992, the French government agreed to sell the ROC 60 Mirage 2000-5 aircraft.

The ROC immediately halted an on-going competition to supply an improved performance engine for the IDF. This was followed shortly by a decision to cut the IDF production program from 240 to 120 aircraft. General Dynamics sold its Fort Worth Division to Lockheed which immediately "right-sized" its IDF work force. The IDF technology transfer agenda was given a dramatically lower priority as the AIDC community worried about its survival following the truncated IDF program. The ROC legislature and the ROC Air Force diverted funds from the IDF program to the F-16 and Mirage acquisitions and reassigned their best people from the IDF to those programs. Any funds which might have been used to improve the IDF were diverted to the F-16 and Mirage, dooming the IDF to never be any better than it is today. AIDC can clearly see that its future as a developer is gone, and it is trying to convince the ROC government to establish it as the depot for life for the IDF coproduced and coassembled systems and subsystems.

Lessons Learned . . . Some Painfully

Aircraft development and test and evaluation in the ROC looked a lot like their counterparts in the US. The processes have the same look, taste, and feel, but the underlying substance has a dramatically different foundation making the outcome unpredictable.

- Foreign advisors are expendable, and in a face-saving situation are there to be sacrificed.
- In a foreign culture, different ethical rules apply. One is sure to confront an ethical dilemma at some point during one's assignment as an advisor.
- In a culture where knowledge is prized for its intrinsic value, do not expect it to be applied.

Mr Romer formerly lived in Taiwan for two years where he was a logistics advisor to the Republic of China Air Force Operational Test and Evaluation Group for the CK-1 Indigenous Defensive Fighter. He is currently working as a journalist for a weekly newspaper, The Voice of Southern Maryland, and is a radio commentator for radio station WMJS in Calvert County, Maryland.





CAREER AND PERSONNEL INFORMATION

Logistics Professional Development

Logistics Officers Cross Flow Program Update

We are now four months into our cross flow program, and each day the Logistics Officer Assignment Branch handles numerous phone calls from officers inquiring on how the program works. This article will clarify the process, emphasize the key role commanders play in the process, and provide a first look at how many officers are in a cross flow position.

Message traffic and briefings from the Air Force Personnel Center (AFPC) and the Air Staff have outlined the rules of engagement for the program; but let's go through the process. Once logistics officers meet the basic requirement of completing four years in their accessed Air Force Specialty Code (AFSC), they are eligible to cross flow. There are two avenues for cross flow—permanent change of station (PCS) and permanent change of assignment (PCA). We'll discuss PCAs first since the program was designed to provide commanders a method to selectively cross flow assigned logistics officers.

Commanders should strive to cross flow officers with no more than two years time on station (TOS). The goal is to ensure officers gain two years experience in the new AFSC without going beyond four years TOS. Under current assignment policy, officers become vulnerable for nonvoluntary assignments when they have three years TOS—we can, on a case-by-case basis, block assignment actions on officers in cross flow status for a maximum of four years TOS.

It is also highly desirable for cross flows to occur as one-for-one swaps. Although not mandatory, PCA cross flows should involve exchanging logistics officers to minimize assignment actions for back fills. When an exchange is not possible, the owning major command (MAJCOM) personnel and functional managers should be part of the coordination process as the one-way PCA will affect career field entitlements. Commanders should communicate their cross flow desires with AFPC in advance to insure there isn't an Air Force requirement that could impede the process. As always, AFPC is the final approval authority for officers changing duty AFSCs to ensure manning levels remain balanced.

The Personnel Concept III (PC III) system is the mechanism for putting an officer in cross flow status. When AFPC can make the cross flow happen, we document the action so the officer gets cross flow credit and schedule the mandatory bridge course training. The PC III action from the unit is critical to finalizing the process.

The opportunity for officers to cross flow at their current station may not present itself so, PCS is the other means to satisfy this goal. The Electronic Bulletin Board (EBB) offers cross flow opportunities for all the logistics AFSCs. Officers seeking a cross flow PCS should look for ad qualifications that indicate a cross flow officer is mandatory, desirable, or acceptable. The normal PCS process is used for assigning officers to these positions. Ad qualifications are provided to us by unit commanders via their MAJCOM. We "best match" and assign officers based on the qualifications in the ads. We are currently working on building a separate category on the EBB just for logistics cross flow assignments.

So you can see, whether it's a PCA or PCS, commanders are the key to the cross flow program. AFPC's Logistics Assignment Team looks forward to continuing to work with commanders and officers in the field to ensure a successful logistics cross flow program.

The following slides reflect a cross flow "snapshot" of AFSCs participating in the logistics cross flow program as of March 1996. Keep in mind that some of these cross flows occurred prior to the 31 October 1995 program start. What these charts do show is that all logistics career fields have officers involved in the cross flow program. Note: The lieutenants in cross flow status are in the process of pinning on captain.

(AFPC Logistics Assignment Team, HQ AFPC/DPASL, DSN 487-3556/5788)

21S Manning and CrossFlow Officers in Supply DAFSC

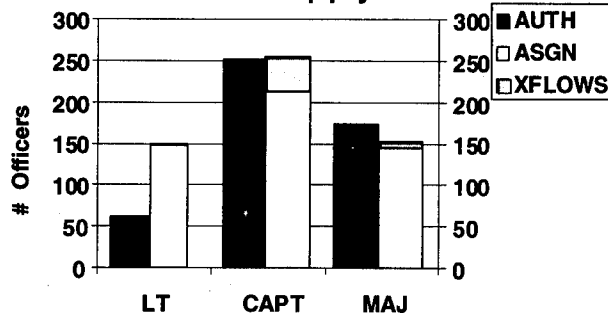

AUTH	62	251	174
ASGN	150	254	153
X F L O W S	2	42	8
FILL PCT	242%	101%	88%
X F L O W %	1%	17%	5%

21T Manning and CrossFlow Officers in Transportation DAFSC

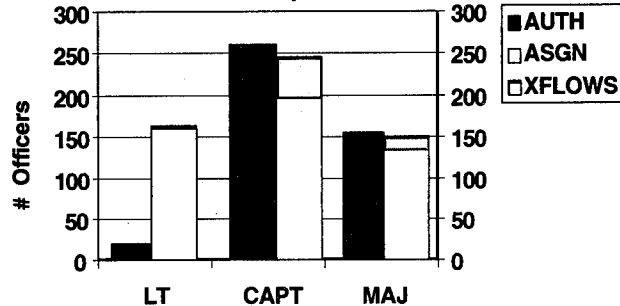

AUTH	20	261	156
ASGN	164	245	150
XFLOWS	3	49	16
FILL PCT	820%	94%	96%
XFLOW %	2%	20%	11%

21M Manning and CrossFlow Officers in Spc/Msl Maint DAFSC

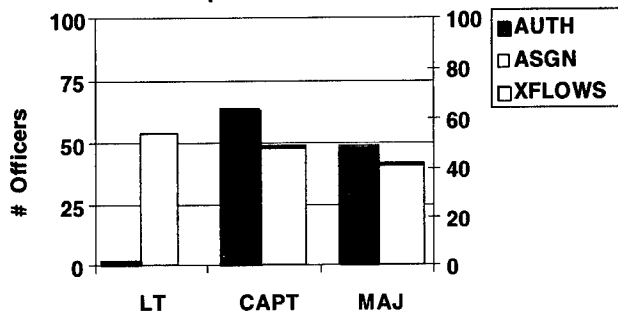

AUTH	2	64	49
ASGN	54	49	42
XFLOWS	0	1	1
FILL PCT	2700%	77%	86%
XFLOW %	0%	2%	2%

21A Manning and CrossFlow Officers in Maintenance DAFSC

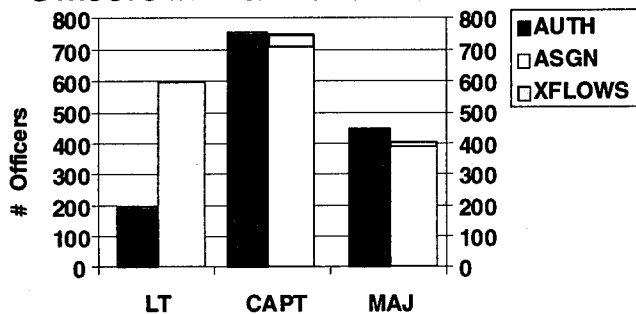

AUTH	194	753	446
ASGN	597	748	406
XFLOWS	1	41	15
FILL PCT	308%	99%	91%
XFLOW %	0%	5%	4%

21G Manning and CrossFlow Officers in Log Plans DAFSC

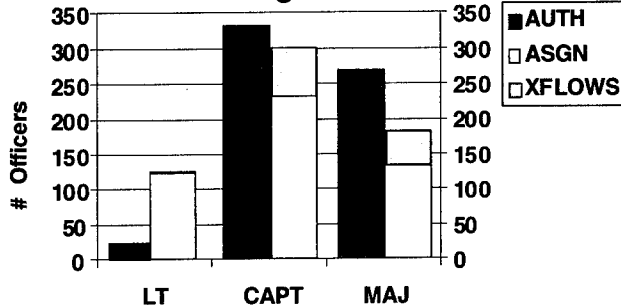

AUTH	24	331	269
ASGN	125	300	182
XFLOWS	2	67	49
FILL PCT	521%	91%	68%
XFLOW %	2%	22%	27%

64P Manning and CrossFlow Officers in Contracting DAFSC

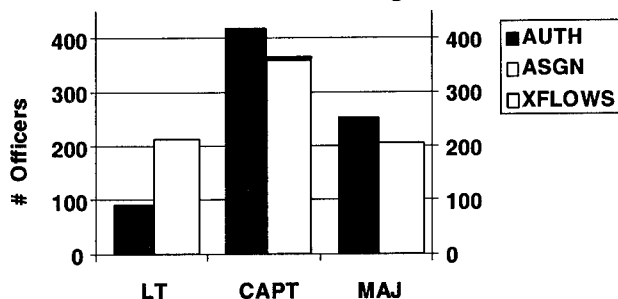

AUTH	94	417	253
ASGN	216	364	206
XFLOWS	0	4	1
FILL PCT	230%	87%	81%
XFLOW %	0%	1%	0%

Logistics Career Broadening Program: A Personal Perspective

Captain Rob Roberts, USAF

Most people who work at Air Logistics Centers (ALCs) have probably heard of the USAF Logistics Career Broadening Program (LCBP), but those who work in other parts of Air Force Materiel Command (AFMC) probably have not. The LCBP is a selective program that provides officers (captains and junior majors) from various career fields the opportunity to gain "wholesale" logistics experience at an ALC in preparation for future leadership positions.

There are a total of 70 LCBP slots spread across the five ALCs. Within an ALC, slots are allocated to the various directorates. The directorate to which an officer is assigned handles personnel and administrative matters and is known as his or her "home directorate." The director of the home directorate is the officer's reporting official. Each ALC manages their program a little differently, but, in general, the first two years of the program (Phase I) consists of six "rotations" of three to six months duration. The program is flexible and the duration of each rotation depends on the background and interests of the individual officer as well as the needs of the organization. Each officer is required to complete a rotation in contracting, program/commodities management, financial management, production (depot maintenance), technology and industrial support, and environmental management. The third year of the program (Phase II) is spent in a "permanent" position, usually in the officer's home directorate, where the officer can apply what he or she has learned in Phase I.

When it began in the 1970s, the LCBP was an Air Force Logistics Command (AFLC) program that allowed officers from "retail" logistics career fields to participate. These career fields included aircraft and munitions maintenance, supply, transportation, logistics plans and programs, and contracting. More recently, when Air Force Systems Command (AFSC) and AFLC merged to form AFMC, financial management and acquisition program management officers were invited to be part of the program. Prior to the command merger, acquisition program management officers or "program managers" worked almost exclusively in AFSC. As only the second program manager to participate in the Oklahoma City ALC program, I'd like to share my thoughts on the benefits the LCBP brings to officers in my career field and the benefits we, as well as LCBP officers from other career fields, bring to ALCs, AFMC, and the Air Force.

Benefits to the Officer

For a program manager who spent eight of his first nine and one-half years in the Air Force at two product centers, the LCBP is truly a "broadening experience." Some officers in my career field are content with staying in the "development side" of AFMC where they have the opportunity to work on weapon system development programs that "push the state of the art." Others,

like me, recognize the sometimes less "glamorous" sustainment business is equally important and challenging, and are enthusiastic about volunteering for the LCBP. I believe getting logistics experience can only make me a better program manager when I return to the product development side of the command. Better, because the LCBP shows "development types" like me the other half of the "big picture" view of the command's business—managing a weapon system through its entire life cycle.

It is imperative that we as system developers seriously consider the implications of a system's design on the operation and sustainment phase of the system's life cycle. A weapon system's design drives its level of supportability, a major determinant of the system's ability to accomplish the mission. In addition, system design can have a dramatic effect on the system's life cycle cost—a factor that has become more important than ever during the current period of declining defense budgets. Many "developers" have heard this discussion in acquisition courses or perhaps program reviews, but few have had the opportunity to experience the sustainment process and see *how* the concept of *design driving supportability* becomes reality. In the ALC environment, it is easy to see first hand how putting too little emphasis on supportability during system design can lead to unacceptably low component reliability and maintenance tasks that are unnecessarily labor intensive. This is invaluable experience for officers who will likely spend most of their remaining career directly supporting a system program director (SPD) or actually being a program manager or SPD at a product center system program office (SPO).

Benefits to the ALC and the Air Force

Program managers who are LCBP alumni will likely return to products centers and may some day be key decision makers on weapon system development programs. Their LCBP experience could impact design decisions resulting in deployment of more supportable systems. This is obviously a potential long-term benefit for the Air Force and especially the "system sustainers" at the ALCs.

All LCBP officers can be valuable assets for the ALC, especially those officers who have been working in field support capacities—the maintenance, supply, transportation, logistics plans and programs, contracting, and finance officers. These officers bring a "users perspective" that can help the ALCs better support their customers. "Career Broadeners" can also take the ALC perspective back to the field so ALC customers better understand the issues and challenges the ALC faces everyday.

All LCBP officers are selected for the program because of outstanding past performance. All are motivated and willing to learn and contribute to the ALC mission. It is a significant

(Continued on bottom of page 19)

Virtual Prototyping for Logistics With Low-End 3D Graphics Programs

James C. Schaaf, Jr.
Curtis W. Walker, CPL

Virtual prototypes are correctly dimensioned, high fidelity scale models of equipment created with a three-dimensional (3D) program in a computer. The creation "exists" as a 3D object in the computer and can be manipulated, modified, and even "entered" for study and analysis. Virtual prototypes are useful during system development for visualizing the item early in the design cycle before production; supporting feasibility analysis; and identifying form, fit, and human engineering problems before pouring concrete or bending metal. This article provides examples of the quality and analytical value that can be obtained for logistics analysis using virtual prototypes generated on low-end 3D drawing programs run on minimum configuration Macintosh computers.

Introduction

The Department of Defense (DOD) defines a virtual prototype as "A computer-based simulation of a system or subsystem with a degree of functional realism comparable to a physical prototype" and virtual prototyping as "The process of using a virtual prototype, in lieu of a physical prototype, for test and evaluation of specific characteristics of a candidate design." (1) Figure 1 shows a moderately detailed virtual prototype of a theater missile defense system concept mounted on a 5-ton medium tactical vehicle (MTV) truck chassis. During the construction of this concept, a Patriot-like missile launcher model was created and mounted on an MTV chassis model created from the manufacturer's drawings. In the computer, the launcher can

be changed from its march-order configuration to a launch configuration by rotating and extending all movable parts as shown in the figure. This quickly identifies several geometric constraints. The physical location of the various parts and their relative movement also dictates some key dimensions and locations:

- (1) Launcher configuration and height to meet C-130 air transport restrictions.
- (2) Location, travel, and bracing for the hydraulic jacks.
- (3) Launcher-erector hydraulic piston length and location.
- (4) Blast deflector shape, location, and clearance.

Figure 2 depicts the location of virtual prototypes within the hierarchy of drawings and mockups used during the hardware development process. There is a trend to skip the mockup phase as experience drives more sophisticated use of virtual prototypes during the design analysis process. (2) Virtual prototypes support higher levels of modeling such as virtual reality (VR) and Distributed Interactive Simulation (DIS). Virtual prototypes should not be confused with virtual reality. Virtual prototypes can be used in a virtual reality "world," but they are equally useful viewed, manipulated, and studied on a two-dimensional (2D) screen or printed to paper.

Virtual prototypes are derived from concept drawings or blueprints and contain as much detail as required to support the immediate need. The same model can be expanded later as more detail is required. For example, testing the fit of a proposed

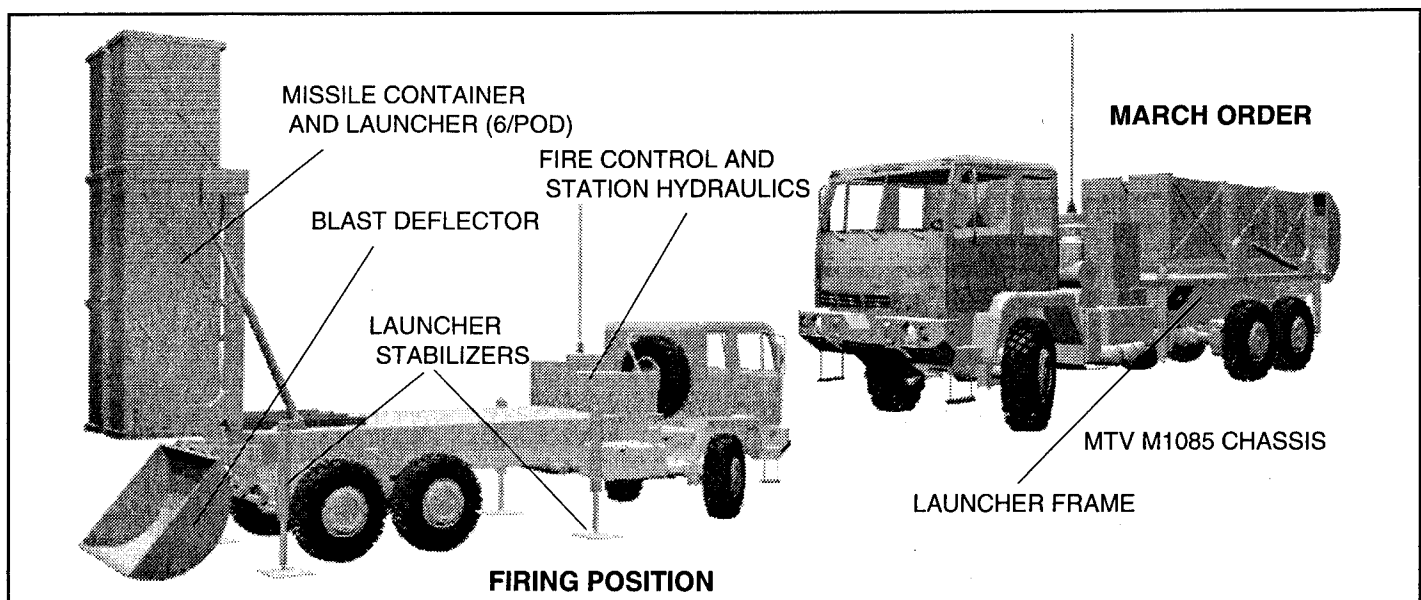

Figure 1. Virtual Prototype Example - Theater Missile Defense System Concept

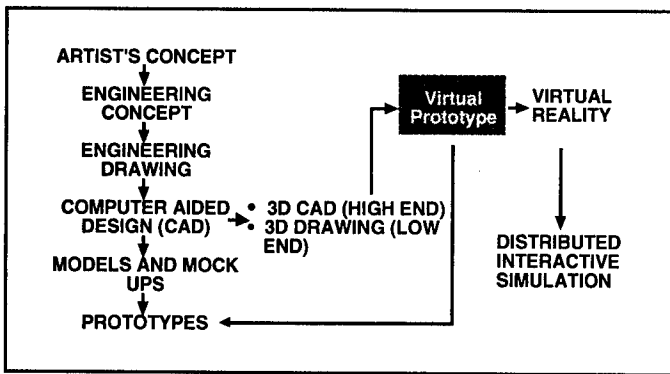

Figure 2. Virtual Prototyping in Engineering

weapon system load on a vehicle may initially require only the length, width, and general shape of the frame. Later, as more details such as outriggers, hydraulic tanks, etc., are required, these can be added along with other underbody details to test for available space and interference.

Virtual Prototyping in the System Development Cycle

Virtual prototypes provide a basic tool to support initial concept development throughout the acquisition process shown in Figure 3, an abbreviated overview of the Army system acquisition cycle. This figure includes the emerging roles of the Army Training and Doctrine Command (TRADOC) Battlelabs and Office of the Secretary of Defense (OSD) and Department of the Army (DA) directed Top Level Demonstrations (TLDs). (3,4) The Department of Defense acquisition process and the Army Science and Technology Guide for new system development include the Advanced Technology Demonstrations (ATDs) that

incorporate new technology into a hardware demonstration and simulation; the planned product improvement (P3I) process that modifies existing equipment; or the initiation of a new system acquisition program with its formal milestone (MS) decision process. (5,6) The Battlelabs drive new concept developments to meet battlefield deficiencies as well as manage the Distributed Interactive Simulation (DIS) for training and mission analysis. The Basic Virtual Prototype (VP) symbol identified in the legend of the figure shows the different stages in the acquisition process that can benefit from using virtual prototyping. Virtual prototypes are useful throughout the various phases of the system development process to show concepts details; identify form, fit, and size issues that in turn support weight, performance, and function issue development. At certain points in the process, virtual prototypes coupled to CAD (computer aided design) or compatible with virtual reality or DIS software provide more benefit and efficiency.

Why Low-End Virtual Prototypes?

Virtual prototyping and photo-realistic rendered drawings convey images of expensive high-end CAD workstations and drawing programs. Less expensive low-end programs can significantly contribute to virtual prototyping for both engineering and logistics analysis. For the purpose of this article, a "low-end" application is defined as costing less than \$1,500 and running on a desktop computer rather than a workstation. The lower cost permits more and smaller contractors to be involved in contracts supporting equipment design and development during the various concept phases noted previously and reduces the cost of implementing virtual prototyping. Even though applications within the \$1,500 end of the scale and higher produce superior photograph-like picture quality, the authors have been

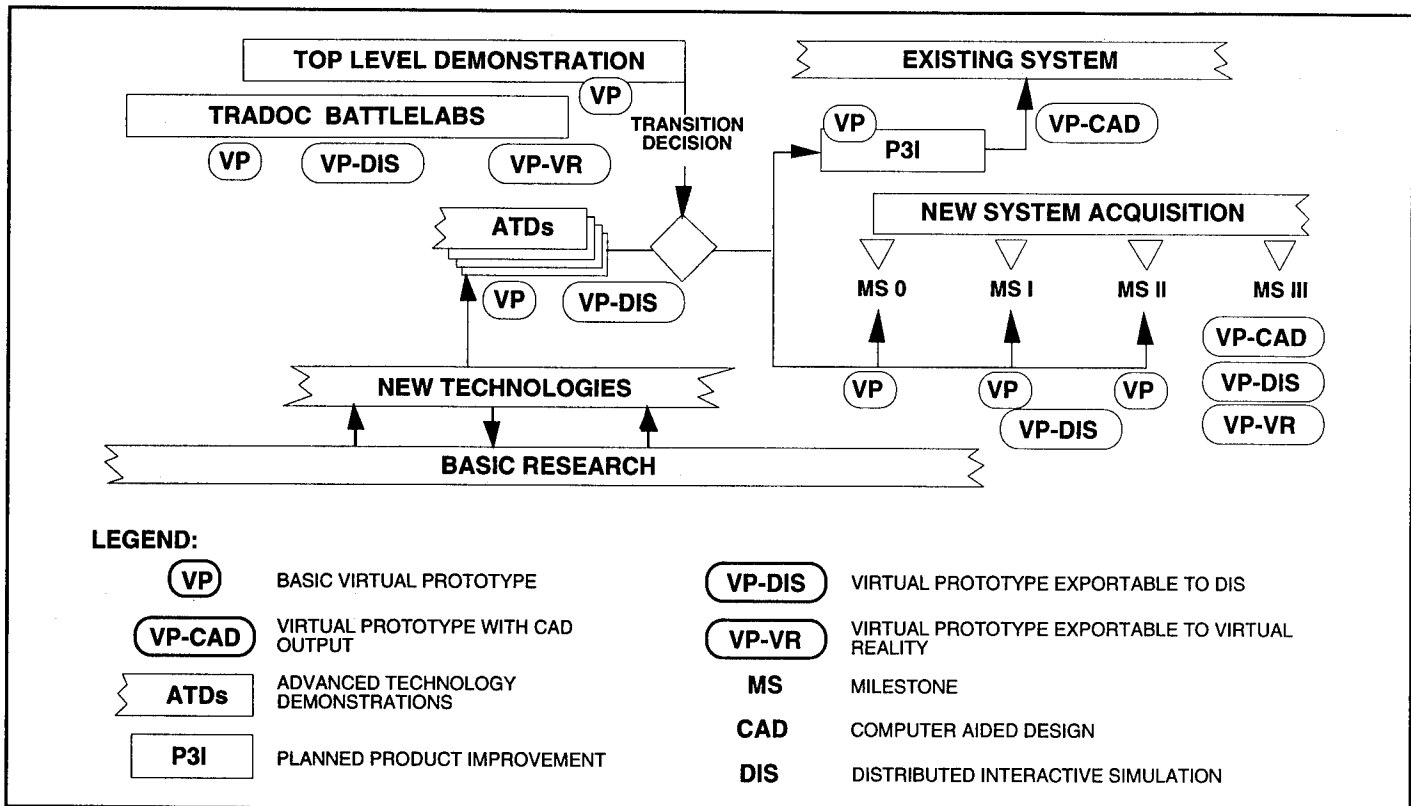

Figure 3. Virtual Prototyping in the Acquisition Process

successful with a \$500 application that produced all of the examples used in this article. Photo-realistic quality and rendering aids such as see-through cutaways, although convenient and impressive, are not essential to the production of useful virtual prototypes during the early development phase.

Virtual Prototyping in Logistics Analysis

Table 1 lists the Integrated Logistics Support (ILS) elements and some areas where virtual prototyping may contribute to the analysis process. The value and level of detail will vary with the complexity and criticality of the system or subsystem being reviewed. Virtual prototyping has previously been associated with the form and fit aspects of engineering design. The authors believe it is also a useful tool for gaining insight into the logistics aspects of new concepts and designs. With the growing need to make more effective use of limited resources, virtual prototyping offers a means for the logistician to communicate with designers and users early in the design cycle before "metal is bent." The following paragraphs select several of the ILS elements and show how virtual prototyping can assist in early identification and resolution of logistics issues. The reader should keep in mind that each figure represents a "snapshot" of a computer screen where the image can be turned about three axes for examination, and components or human figures can be moved and repositioned by the computer operator.

Maintenance Planning

For this ILS element, accessibility analysis is probably the area most strongly supported by virtual prototyping. Some potential exists for showing parts fit and assembly and disassembly procedures. Figure 4 illustrates a model of a portion of a magnetic levitation test device that has been built and successfully tested. The model was initially created to improve communication with a fabrication shop. This model was easily "exploded" on the computer screen to show how the components were assembled. "Snapshots" of different phases of the assembly sequence were also used as figures in the instruction and maintenance manual written for the test device.

Figure 5 shows a model of a design for a fighting vehicle system (FVS)-mounted theater missile defense interferometer radar. Positioning the human figures on the model shows possible locations for operating or maintenance panels accessible from

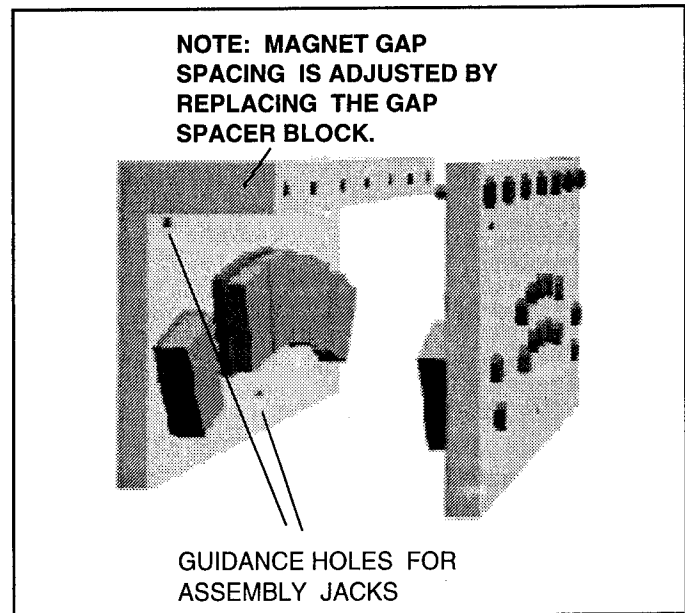

Figure 4. Assembly Breakout

ground level on the outside, or, with the mast elevated, from the inside. The FVS virtual prototype model is one of several common military prime movers created and maintained on file by the authors for new weapon concept "assembly" and form and fit assessment. This model is highly detailed and includes doors that open, interior cab details, and hinged cab armor that opens or "buttons up" to test the model in either its fighting or travel configuration.

Manpower and Personnel (Human Factors Assessment)

The insertion of anthropometrically correct models of human figures into virtual prototype equipment models can test the feasibility of proposed operations and assists with early identification of problem areas and issues requiring detailed study. Figure 6 shows a portion of a potentially hazardous assembly operation. Due to powerful magnetic forces, the "weight" of the plate "held" by the human models increases to over a thousand pounds as the device is brought closer to the bottom plate during assembly. To test the proposed procedure, the top plate was moved in stages through its motion path. The human figures were moved to maintain contact with the plate. At the different stages, the figure positions were checked to ensure

ILS ELEMENT	VIRTUAL PROTOTYPE APPLICATION
MAINTENANCE PLANNING MANPOWER AND PERSONNEL SUPPLY SUPPORT SUPPORT EQUIPMENT TECHNICAL DATA TRAINING AND TRAINING SUPPORT COMPUTER RESOURCES SUPPORT FACILITIES PACKAGING, HANDLING, STORAGE, AND TRANSPORTATION DESIGN INTERFACE	ACCESSABILITY ANALYSIS HUMAN SYSTEMS INTEGRATION BASIC LOAD STOWAGE AND HANDLING ENGINEERING FORM, FIT, AND FUNCTION THREE-DIMENSIONAL TO TWO-DIMENSIONAL ILLUSTRATIONS ANALYZE HUMAN ACTIONS ENGINEERING FORM, FIT, AND FUNCTION PACKAGING AND HANDLING CONCEPTS LOAD CONFIGURATION AND FIT ENGINEERING FORM, FIT, AND FUNCTION

Table 1. Integrated Logistics Support Elements and Associated Virtual Prototype Application

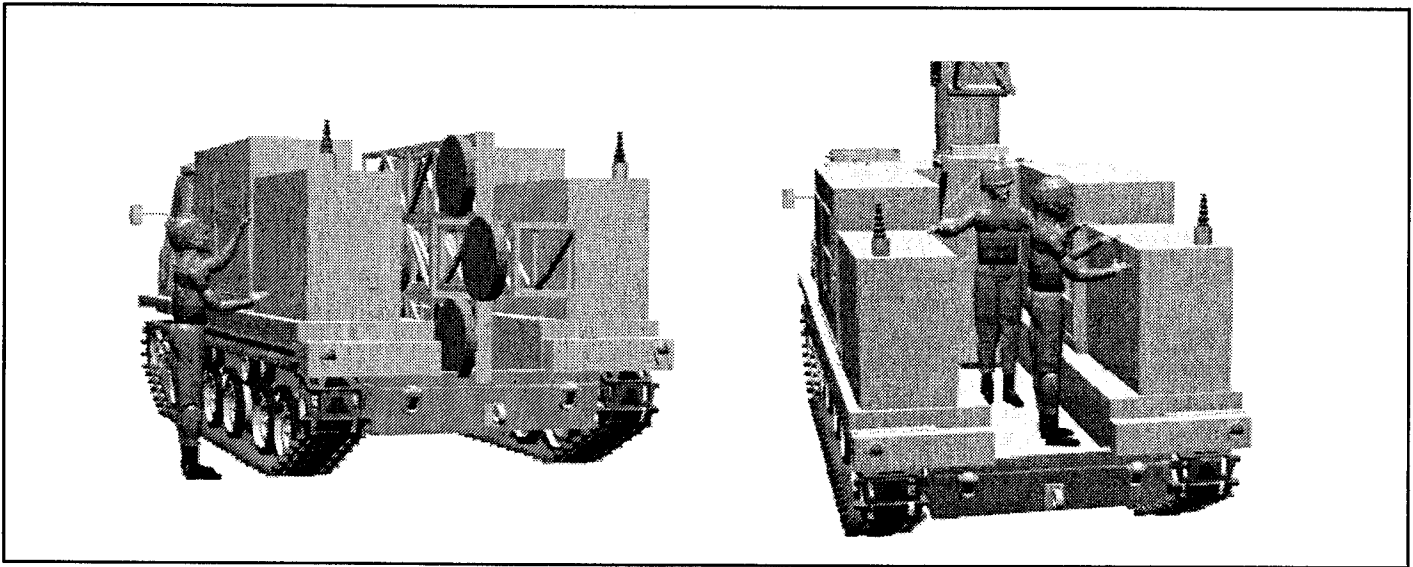

Figure 5. Maintenance Accessibility

no awkward positions or unbalanced stretching were required during the assembly process. Several "snapshots" of the computer screen were taken and the resulting images were included in the instruction and maintenance manual prepared for the test team.

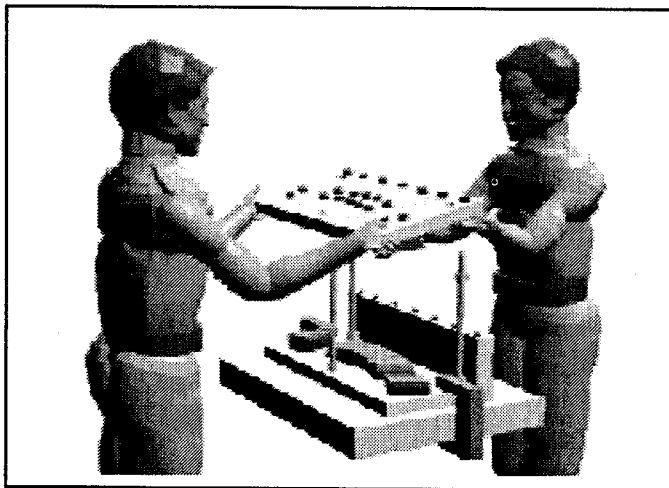

Figure 6. Human Factors - Assembly

Figure 7 (next page) illustrates two of several light air defense concepts developed to fit on a Land Rover. The approximate sizing for the standing-operator version was quickly determined by first positioning the human figure in the bed of the Land Rover and then creating the launcher support stand and controls around the figure. The pods were rotated and elevated in the computer to test clearances and drove the trunnion height to a level that eliminated interference. To reduce computer memory requirements and eliminate distracting details, the cargo bed was removed from the Land Rover model during the support stand construction and later reassembled with the vehicle model to confirm cab clearance. The seated version on the right was reconfigured after slewing in azimuth caused the operator's feet to penetrate through the cargo bed side panels.

Packaging, Handling, Storage, and Transportation

Figure 8 shows a conceptual air defense system mounted on a High Mobility Multipurpose Wheeled Vehicle with one of its configuration options for stowing eight missiles for reloading. In the computer, the launcher can be placed in a worst-case position for launch-blast impingement on the missile containers. Then, by measuring the distance from the launch motor nozzle and container, the blast overpressure effects can be assessed.

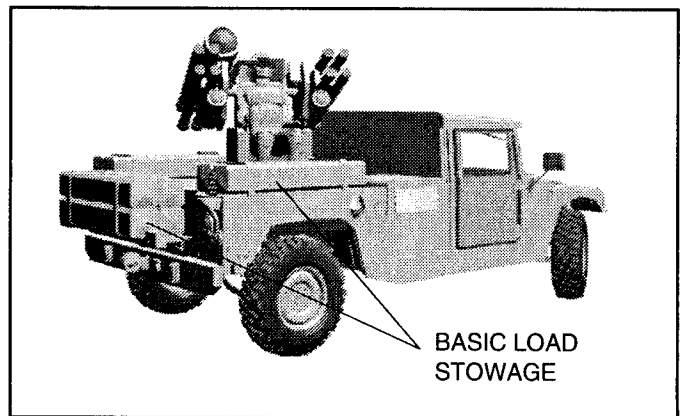

Figure 8. Basic Load Stowage

Virtual prototypes are useful for testing space constraints and fit in various shipping configurations to meet rail, air, or sea transportation requirements. Figure 9 (next page) shows a conceptual electric gun being tested in a box representing the transport enclosure limits for a C-130 aircraft. The gun system was developed and sized based on detailed calculations using state-of-the-art pulsed power components and actual test firing results. The tractor and gun trailer can be moved in the computer to test the trailer bottom clearance at the loading ramp hinge as well as the ceiling clearance. The gun and tractor are detailed three-dimensional models in the computer. (This is the same gun shown in Figure 10 on the following page.) Figure 9 illustrates a desirable feature of some 3D drawing programs that transforms a shaded surface perspective scene into an orthographic line

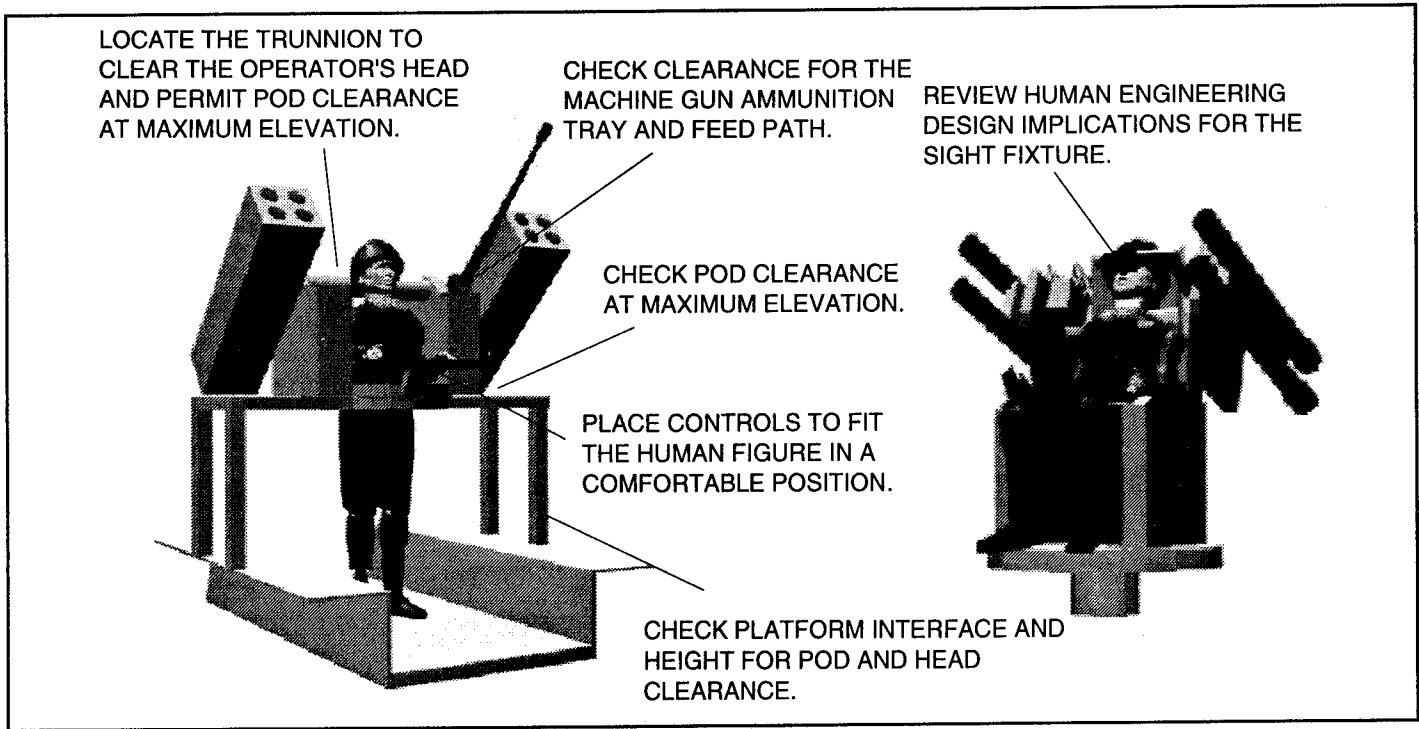

Figure 7. Human Engineering Issues

drawing. This line drawing format is more suitable for this type of analysis and resulted in several changes to the concept model to make it air transportable. A previous article by one of the authors (see Reference 7) has identified minimum and desirable drawing features such as this that are required by low-end 3D drawing programs to produce usable virtual prototype models. (7) An essential feature is a ruler or scaled background grid that assists the operator in creating components and subsystems to scale from drawings or blueprints. Creating ruler models that are 8 to 10 feet in length and inserting them into the model scene also helps to check the dimensions of new parts and their location with respect to other components.

Support Equipment and Design Interface

The application of virtual prototyping to these two ILS elements is one of the simplest tasks to implement. Requirements

and issues related to the location and fit of support equipment and features of interface requirements are easily illustrated and studied on the computer screen in real time. The logistics engineer can work with the design engineer on the same database early in the design concept development phase. The partially completed electric gun model in Figure 10 illustrates how an overview of the proposed concept or design can assist in identifying and addressing support equipment and design interface issues. In the computer, the bogie can be elevated, lowering the trailer frame to the ground. The gun barrel can be extended or retracted from battery to out-of-battery position, and the gun can be moved in azimuth and elevation. Recoil can be shown in an animated firing sequence. In a theater missile defense role, the batteries must be recharged or exchanged after twenty rounds have been fired, and a materiel handling crane on a service vehicle or the gun trailer will be required. A virtual

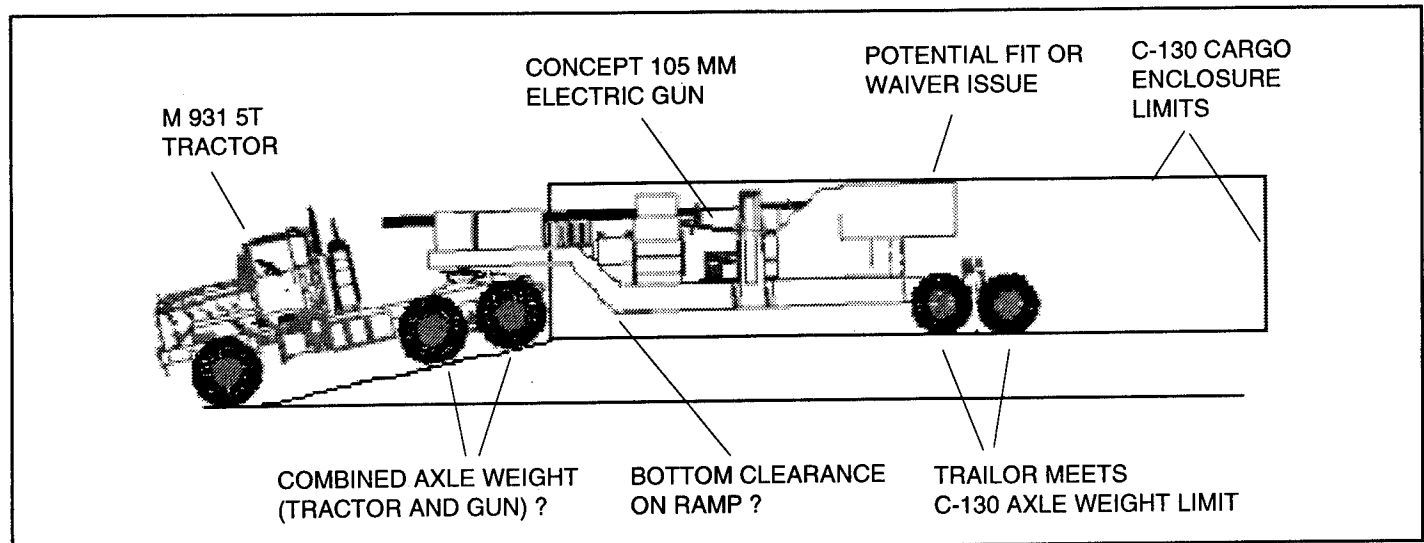

Figure 9. Aircraft Loading Analysis

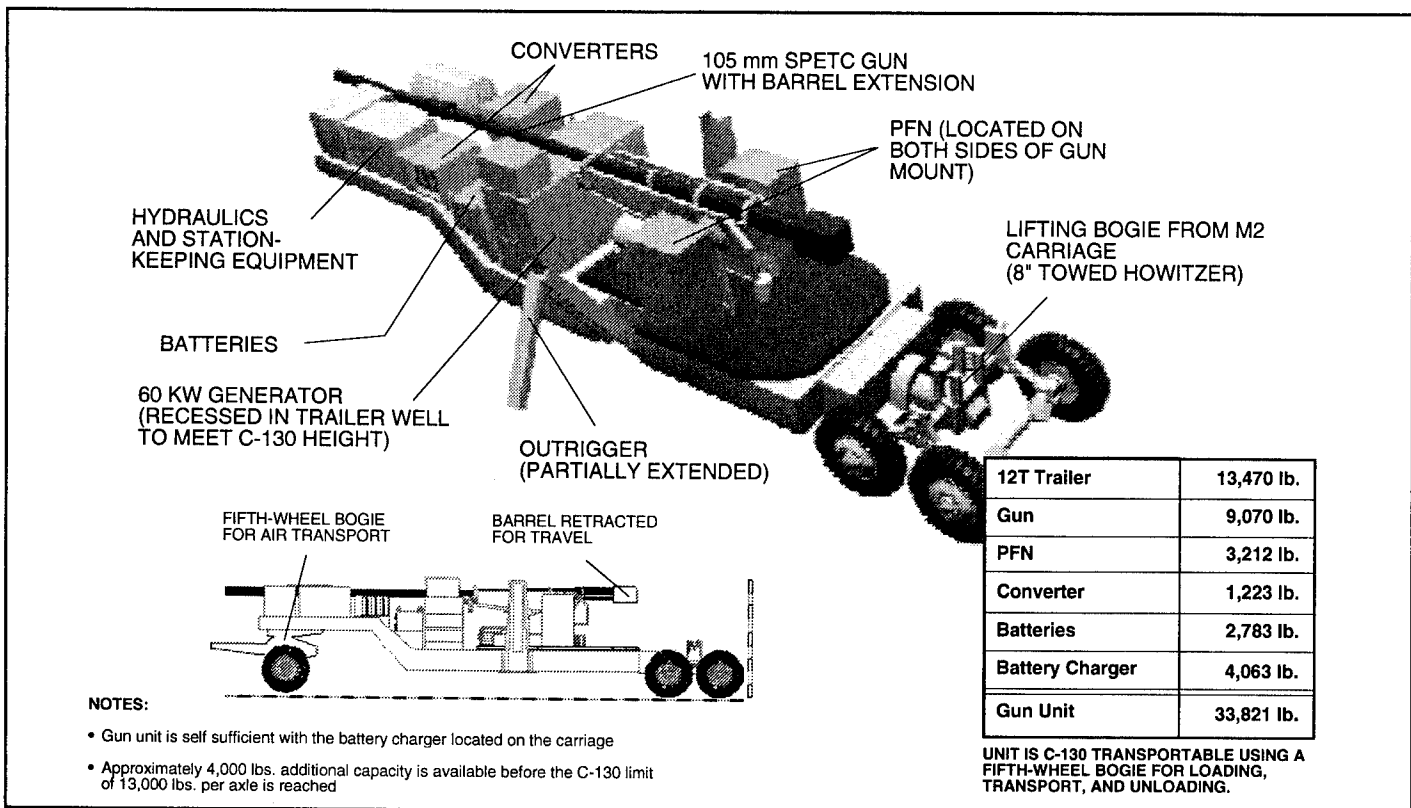

Figure 10. Design Interface

prototype hydraulic crane is being created from manufacturer's drawings to test fit and reach at various locations. A folding "A-frame" crane can also be created and "tested" on the trailer. Although the model includes outriggers, these may not be needed since the total mass of the trailer provides the firing platform. The model contains all of the dimensional relationships needed to calculate stability. Finally, an autoloader for automated rapid fire must be added to complete the concept. The ability to elevate the barrel and add recoil travel will permit testing the autoloader system design interface.

Summary

Through careful development of details, low-end 3D graphics programs run on low-cost computers can generate virtual prototypes that provide a useful engineering tool supporting logistics early in the concept development phase. Virtual prototyping permits users, designers, and logisticians to visualize two- and three-dimensional relationships and clearances for joint analysis. In addition to improving communication and coordination, this process also contributes to concurrent engineering. This early analysis and identification of design issues offers potential to reduce development costs since mistakes will be made in the computer rather than on bent metal. Low-end software does not require specialized training, and engineers and technicians can quickly learn to use this as a desktop design aid. The lower cost of low-end software and equipment permits more small businesses to enter this arena and provides a larger competitive support contractor base. Military equipment examples have been used in this article, but virtual prototyping

applies equally well to the commercial arena. Typical application areas can include fitting a new manufacturing line into an existing warehouse or installing new seating designs in buses.

Numerous 3D graphics programs are commercially available. Their quality and number of features have grown rapidly over the past several years and continue to improve. The quality, features, and lowering prices tend to blur the distinction between basic applications, making it increasingly difficult to choose one application over another.

References

1. Garcia, A.B., Gocke, R.P., and Johnson, N.P. *Virtual Prototyping, Concept to Production*, Defense System Management College, Fort Belvoir, Virginia, 1993.
2. Piplani, L.K., Mercer, J.G., and Roup, R.O. *System Acquisition Manager's Guide for the Use of Models and Simulation*, Defense System Management College, Fort Belvoir, Virginia, 1994.
3. TRADOC Regulation 11-1, *Battlefield Laboratories Program*, Department of the Army, Fort Monroe, Virginia, 1994.
4. *Advanced Land Combat, Strategic Plan for DoD Science and Technology Thrust 5*, Department of Defense, Washington, DC, July 1993.
5. DOD Instruction 5000.2, *Defense Acquisition Management Policies and Procedures*, Department of Defense, Washington, DC, February 1993.
6. *Army Science and Technology Master Plan*, Department of the Army, Washington, DC, November 1992.
7. Schaaf, J.C., Thompson, F.L., and Churchwell, V.D. "Virtual Prototyping with Low-end 3D Graphics Programs," *Proceedings of the 1994 Winter Simulation Conference*, Orlando, Florida, December 1994.

Mr Schaaf is presently a senior systems engineer in the Technology Applications Group at BDM Federal, Inc., Huntsville, Alabama. Mr Walker is a systems analyst in the Strategic Applications Group also at BDM Federal, Inc. 

Individual Mobilization Augmentees in Logistics

*Captain Stella T. Smith, USAF
Captain Mark A. Gray, USAF
Captain Mark A. Abramson, USAF*

Background

Downsizing has forced Air Force leaders to find ways to better use all resources at their disposal. General Ronald R. Fogleman, Air Force Chief of Staff, stated he intends to find “better ways to use the total force” and sees “the value of making good use of the reserve components.” (1) It is critical the Air Force consider innovative approaches to increase utilization of the pool of qualified “ready reserve” individuals. One proposed approach is to expand the role of Individual Mobilization Augmentees (IMAs) in logistics career fields. An IMA is a trained member of the Selected Reserve assigned to an active duty organization to support implementation of war or contingency plans and to respond to other situations that national defense strategy or national security objectives require. They are required to perform a minimum of 12 to 14 days annual training days; inactive duty training is optional, varying from 0 to 48 paid or unpaid days.

Numerous Air Force Specialty Codes (AFSCs) currently use IMAs; medical, legal, and chaplain comprise a major portion of these uses. IMAs are also present in logistics career fields. For example, IMAs comprise the Air Force Reserve Ammunition Teams (AFRATs) which augment Army munitions depots storing Air Force munitions.

The success of the AFRATs prompted a study to examine the potential for expanding the use of IMAs in logistics career fields. The Air Force Logistics Management Agency (AFLMA), at Maxwell AFB, Gunter Annex, Alabama, was tasked to study the current use of logistics IMAs, look at the AFRAT program, and determine whether it is feasible to use more enlisted logistics IMAs. This article presents the findings of the study.

Current Air Force IMA Usage

Our first step was collecting data from Air Reserve Personnel Center (ARPC) in Denver, Colorado, showing which logistics career fields and major commands were already utilizing IMAs as of April 1995. Figure 1 shows logistics IMA usage by AFSC and by major command. The percentages are based on a total number of 1,512 logistics IMAs.

As can be seen in Figure 1, aircraft maintenance is the logistics career field using the largest number of IMAs, 30%. The supply and transportation fields are also well represented, and together the three AFSCs comprise over two-thirds of IMA usage. The Air Force Materiel Command (AFMC) is by far the primary user of IMAs in logistics fields at 58%.

IMA Allocation Process

Once we determined current uses, the next step was to examine how IMA positions are created and filled. The IMA allocation

process consists of three primary levels: base, major command, and Air Force Reserve general officer board. At the base level, an organization desiring an IMA begins the process of creating an authorized position by providing justification and gaining approval through the manpower system. This is very similar to the process used to get authorization for any manpower slot.

Once base manpower approves the IMA billet, the base feeds information to major command (MAJCOM) representatives. At the MAJCOM level, IMA managers prioritize all IMA slots and develop further justification before presenting their lists at the Individual Mobilization Augmentee Allocation Team (IMAAT) conference at the Air Reserve Personnel Center (ARPC) in Denver, Colorado. The IMAAT, the third level in IMA allocation, is a board of Reserve general officers which has all IMA allocation authority but no ability to change Congressionally-determined end strength. In other words, they decide which slots will be funded, but they are unable to fund beyond the predetermined limit. At the conference, MAJCOM representatives promote proposed new allocations and offer up slots they are willing to lose if the IMAAT decides to rearrange allocations. The IMAAT then prioritizes all slots based on MAJCOM presentations and decides which slots receive allocations. (2)

During the April 1995 IMAAT conference, team members' most positive comments went to MAJCOM representatives who could show three things: (1) they had used all their allocations in the past (that is, not let any sit unfilled), (2) they could predict the potential benefit of the IMAs requested, and (3) they were certain they could fill a slot if it was allocated. The preponderance of general officers traveling to Denver to personally present requests for additional IMAs demonstrated the importance placed on the IMA program at MAJCOM level. Observation and discussions with MAJCOM representatives indicate the current process for IMA allocation is fair and well-accepted.

One concern about the IMA billet establishment and allocation process which surfaced several times was the specific limitation which forces units to justify positions based only on wartime roles. Department of Defense (DOD) Directive 1235.11, *Management of Individual Mobilization Augmentees (IMAs)*, states that IMA billets shall not be authorized for peacetime augmentation or to resolve peacetime manning shortages (although there are case-by-case exceptions for individuals with specific skills). (3) During the last rewrite of directives, there was discussion about allowing peacetime roles as justification for IMA billets where an IMA position may fill a need better than an active duty slot.

Overall, the IMAAT system works well. The process requires operational units, MAJCOMs, and the IMAAT to regularly

INDIVIDUAL MOBILIZATION AUGMENTEE UTILIZATION

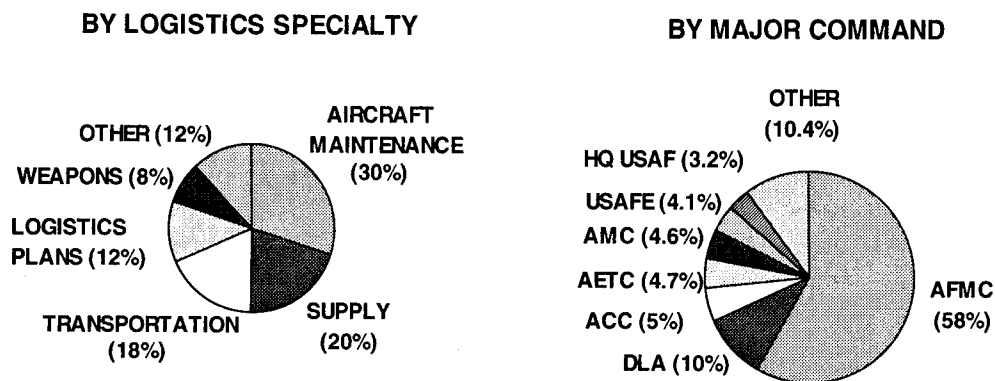

HQ USAF - HEADQUARTERS UNITED STATES AIR FORCE
USAFE - UNITED STATES AIR FORCES IN EUROPE
AMC - AIR MOBILITY COMMAND
AETC - AIR EDUCATION AND TRAINING COMMAND
ACC - AIR COMBAT COMMAND
DLA - DEFENSE LOGISTICS AGENCY
AFMC - AIR FORCE MATERIEL COMMAND

Figure 1. Air Force Individual Mobilization Augmentee Utilization

prioritize and reevaluate all IMA slots. The continual evaluation and justification creates a strong process for managing a limited resource. One limitation inherent to the system is that the demand for IMAs should be created at the unit level, yet, in many cases, logisticians are not adequately familiar with the IMA program or the process for adding IMA slots.

Expanded Use in Logistics Fields?

To determine whether it is feasible to expand use of enlisted logistics IMAs, we decided to go to the experts. Students in Senior NCO Academy class 95-C provided this expertise. Members of a Creative Problem Solving Seminar helped develop, test, and implement a survey which addressed the IMA program. Surveys were then distributed to and collected from all 163 logistics senior NCOs in Academy Class 95-C. The response rate was 100%, which is remarkable. While sample sizes for most career fields (all except 2A, aircraft maintenance) were not large enough to apply stringent statistical procedures, the responses yield some insightful results.

The respondents indicated that many units have commitments during contingencies, such as wartime or deployment, which may require additional personnel to accomplish their mission. Even so, we found 82% of the respondents believed their unit could accomplish their mission without IMAs. The survey also asked whether members of the respondent's career field were tasked to augment other AFSCs during a contingency. Twenty-seven

percent of the respondents indicated this augmentation policy exists.

Special requirements (licensing, qualification requirements, security clearance, etc.) placed on specific jobs or career areas can greatly impact potential usage of IMAs. Ninety-three percent of the respondents indicated special requirements exist within their unit and career field, but only 41% indicated requirements would preclude use of IMAs. This percentage drops to 23% for respondents in the supply and transportation fields. Although only 29% of the SNCOA students surveyed have worked with IMAs, 61% believe the concept works or could work in their career field.

Overall, this survey of logistics experts shows there is clearly room to expand the use of IMAs in logistics career fields. According to more than half the respondents, special requirements do not exclude expanded use. In addition over half the respondents believe IMAs could contribute in their career fields. Some responses to the surveys indicated a need to further educate base-level managers on the particulars of the IMA program.

Potential IMA Pool

To determine whether there is room for expanded use of logistics IMAs it was not only necessary to assess whether their use is feasible, but also whether there are personnel in the potential IMA pool who can be recruited to fill logistics positions. We extracted data from ARPC's database to show which logistics

career fields demonstrate potential for increasing IMA use. Table 1 shows the four logistics career fields with the most enlisted personnel eligible to become IMAs (current as of 25 July 1995). These numbers show the career fields with the greatest possibility of IMA matches.

Career Field	Number of Potential Individual Mobilization Augmentees
Aircraft Maintenance	13,564
Transportation	4,368
Supply	3,914
Munitions Maintenance	3,414

Table 1. Potential Enlisted Individual Mobilization Augmentees

These numbers clearly show there is a great potential to find new logistics IMAs once an allocation is approved. Each IMA position is developed with unique requirements including rank, experience, distance from residence to work, and assignment and attachment location. Once an allocation is decided upon by the IMAAT, Air Force Reserves (AFRES) recruiters use the ARPC database to match candidates from the potential IMA pool. The recruiters then approach the candidates and offer them IMA positions. A representative at HQ AFRES recruiting said they rarely have trouble finding people to take IMA positions. They are more often in the position of telling people who wish to be IMAs that no slots are available.

Recruiters are not the only people in the process who may use the ARPC database. During the IMA allocation process, detailed earlier, units or MAJCOMs can establish criteria for each IMA slot, and then can search for potential matches. AFRES recruiters are the most frequent users, but anyone can request information—MAJCOMs, bases, or units. Customers may query the database using one or many delimiters such as AFSC, experience level, zip code, and rank. It currently takes about one week to process requests, unless they are extremely customized. Most output is in a hard copy form and includes all information about the Ready Reserve members who meet the criteria; however, ARPC programmers can also provide electronic data on diskette if given additional time. Querying the database prior to prioritizing slots is a good practice to prevent the situation of gaining approval from the IMAAT and then having a slot sit unfilled because there is no match.

A Successful IMA Program

One exemplary example of expanded use of logistics IMAs is the Air Force Reserve Ammunition Team (AFRAT) program. The IMA billets were created under the traditional "wartime only" reading of the directives, but the program is also a great benefit to the Air Force in peacetime. The AFRATs are Air Force munitions technician IMAs attached to Army depots storing Air Force ammunition. Their function is to provide surge capability in time of war, but they also maintain Air Force munitions during peacetime.

The AFRAT program was initiated due to unprecedented munitions retrograde from overseas, continuing procurements, base realignment and closure actions, and budget reductions that severely constrain the Army's ammunition management and maintenance capabilities. The AFRAT program is governed by a Memorandum of Agreement with each of the Army's four Tier 1 depots. These depots, Blue Grass, Kentucky; Crane, Indiana; McAlester, Oklahoma; and Tooele, Utah, house the preferred munitions that will be required during the initial 30 days of a conflict. The AFRAT operation is very successful. From August 1994 to March 1995 there were 101 IMAs assigned to the program. During that time they made over \$14 million worth of Air Force munitions components available at a cost of only \$93,000.

This operation could serve as a benchmark for other IMA initiatives. A key to the program's success is the flexibility built into the program. The number of days IMAs work is adjusted based on workload. Funding is provided by the MAJCOM for which they work. The concept of using IMAs as a team works well because members can work when they are available without halting production. The AFRATs are maintaining and inspecting munitions that would have otherwise been untouched, and the program enables the Air Force to capitalize on talents of trained munitions technicians leaving active duty.

Conclusions

Overall, below the MAJCOM level in the logistics community, there is poor awareness of what IMAs are, how slots are created, and how the program works. Although the allocation process currently works well, increasing knowledge at base level can only help the program and contribute to increased readiness. The AFRAT program demonstrates that creativity in creating and managing IMA positions can provide needed augmentation to logistics manpower. Base-level managers are best suited to determine whether they have a need for an IMA, but to do this, they must have knowledge of the program. Since the number of IMAs is limited, program knowledge and understanding at the lowest level possible is essential in ensuring positions are allocated to the most appropriate units. With continued downsizing, it is crucial that logisticians at all levels take a close look at the IMA program and attempt to use this resource to augment their capabilities. IMAs are a force-enhancing opportunity which should not be ignored.

References

1. Pomeroy, Gary, MSgt. "Fogleman to Examine Total Force," Air Force News Service, March 1995.
2. Nester, Robert, Maj Gen. "Individual Reservist Allocation Team Meets to Distribute IMA Resources," *IMA Update*, Vol. 7, No. 3, May 1995.
3. DOD Directive 1235.11, *Management of Individual Mobilization Augmentees (IMAs)*, 17 January 1989.

Captains Smith and Gray are project managers in the Maintenance and Munitions Division of the Air Force Logistics Management Agency (AFLMA), Maxwell AFB, Gunter Annex, Alabama. Captain Abramson is an analyst at the AFLMA. 

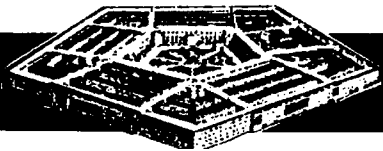

Air Force Outsourcing and Privatization Program

One of the newest and most promising initiatives being worked throughout the Air Force is outsourcing and privatization. The objective of this program is to increase effectiveness and save money by integrating private enterprise into all appropriate areas of the Air Force infrastructure. To achieve this goal, outsourcing and privatization integrated process teams are being established in many organizations. In addition to identifying and cross flowing ideas for potential outsourcing and privatization studies, these teams will be involved with establishing baselines on which to gauge progress, measuring results, and reporting successful initiatives.

Areas which are not inherently governmental, military essential, or legislatively protected are candidates for outsourcing and privatization, provided their conversion does not negatively impact readiness. Some potential areas for early benefits include base support activities, military family housing, education and training, and base realignment and closure (BRAC)-related functions such as depot maintenance.

The Air Force Outsourcing and Privatization Office is located in Room 4B267 in the Pentagon, and can be reached at DSN 223-7756. Call them to find out how you can use outsourcing and privatization as an Air Force leadership tool! (Lt Col Wilsey, HQ USAF/LGM-1, DSN 227-6275)

New Defense Transportation Regulation

The United States Transportation Command (USTRANSCOM) has taken 44 disparate common user, multiservice transportation regulations totaling over 2,200 pages and reduced them to one four-volume, 1,000-page regulation that will be the transporter's one-stop reference when it is completed in 1996. The streamlined *Defense Transportation Regulation (DTR)*, DOD Regulation 4500.9-R, will allow transportation specialists worldwide to more efficiently perform their jobs.

In January 1993, USTRANSCOM assumed responsibilities for transportation policies and procedures previously assigned to each of the military Services. Shortly thereafter, a DOD-wide review of transportation regulations found many to duplicate, supersede, or even conflict with other Service guidance. Following a March 1994 directive from the Deputy Undersecretary of Defense for Logistics, representatives from each of the military Services, the unified and theater commanders, and USTRANSCOM's component commands (Air Mobility Command, Military Sealift Command, and Military Traffic Management Command), met at USTRANSCOM to review all common-user traffic management guidance. The group recommended that 44 existing transportation directives be consolidated into one comprehensive Defense Transportation Regulation. The revised regulation addresses passenger movements, cargo, mobility, and personal property. It also provides guidance for military operations such as humanitarian relief and peacekeeping, missions largely new to the military, yet increasingly routine.

The *DTR*, as published, is the single reference for all DOD transportation specialists, whether they are working in a unified command or at the base or installation transportation office. The passenger movements portion, effective 4 August 1995, is now available both in hard copy and on CD-ROM. The cargo movements and mobility portions are in their second draft undergoing review. The personal property portion, currently in its first draft, will be completed in early 1996.

The full four-part *DTR* will be published both in hard copy and on CD-ROM in July 1996. There are also long-range plans to make it available through the Internet. DOD agencies will receive their copies of the *DTR*, as each part becomes available, through normal publication/supply distribution channels. Authorized registered DOD components and their contractors can order each part from the Defense Technical Information Center, Cameron Station, Alexandria, VA 22304-6145. Government agencies, including DOD components and contractors, as well as members of the general public, can obtain copies for a fee by contacting the US Department of Commerce, National Technical Information Services, 5285 Port Royal Road, Springfield, VA 22161.

Major Joseph Cruz, USAR
Office of Public Affairs
United States Transportation Command
Scott AFB, Illinois

Pollution Prevention: Planning to Save

Cathy Andrews

Introduction

We can no longer afford to generate waste without considering its impact on mission accomplishment, productivity, sustainability, and survivability. The Naval Surface Warfare Center, Crane Division has undertaken a unique initiative to bring this notion home to its managers and employees. Applying the tools of logistics and the mechanisms of the Safety Stand Down concept, Crane developed a Pollution Prevention Stand Down (PPSD). All employees at the Crane site stopped work for a few hours to become educated on pollution prevention principles and apply them to each of their processes. During this time, employees analyzed their process flows, identified types and amounts of related wastes, and developed projects to eliminate or reduce at least one waste in each process. Examples of projects resulting from these plans include the elimination of isocyanate compositions in packaging manufacture, substituting nonhazardous for hazardous materials in printing operations, paper reduction through enhanced use of electronic media, and water conservation from closed-looping efforts.

Background

After glancing over the Introduction, you may say to yourself, "What does this initiative have to do with logistics?" "Lots" is the answer. Not only was this effort a major logistics enterprise in itself, but it served as an important tool in educating our personnel on environmentally related life cycle management issues. It also provided them the opportunity to apply what they learned during the PPSD process to save resources—water, energy, personnel, and raw materials.

The PPSD concept was born during a Pollution Prevention Management Action Team (MAT) meeting. This MAT is a multidisciplinary team of individuals from support and line functions in the Crane Division. It includes engineers, scientists, administrators, and financial as well as environmental specialists. The focus of the MAT is the development of tactics to incorporate pollution prevention measures in Crane's operations.

The members of the MAT were looking at different methods to educate Crane's employees on hazardous material control issues. They felt that a unique approach, such as a PPSD consisting of training modules and exercises, would be an effective empowerment tool to accomplish this. The concept was then expanded to include other elements of pollution prevention, including recycling, water and energy conservation, and paper reduction. A Cross Functional Support Team (CFST) was then chartered by the Pollution Prevention MAT to implement the PPSD at the Crane site.

The PPSD CFST consisted of representatives from the Pollution Prevention Office, the Environmental Protection Department, and a production directorate. The group developed

a PPSD Plan which was approved by the division commander for implementation at the Crane site in October 1993. As part of the plan, the team produced a local video entitled "Pollution Prevention: The Key to Environmental Protection." This video covered Crane's environmental program, concepts of pollution prevention, and examples of their application at the Crane site. The team also developed field exercises on process flow analysis, waste identification, and prevention. These exercises covered office processes as well.

PPSD Methodology

Training and education is a key logistics element in life cycle management. The PPSD was primarily designed to educate Crane employees on how to apply pollution prevention concepts to each of their processes. To gain working knowledge of pollution prevention principles, as they apply to Crane, each employee was required to view a 20-minute locally produced videotape. The employees then formed teams to review each process and to complete related exercises. The ultimate goal of these procedures was to make them aware of sources and quantities of waste generated in their operations and to help them apply what they learned about pollution prevention to eliminate and reduce a targeted waste.

PPSD teams were allowed up to four hours to complete the exercises. The employees were empowered to develop and execute a source reduction plan for one of their identified wastes, based on criteria provided. The teams were given a year to implement their plans. They were asked to identify their progress in quarterly status reports submitted to the Division's Pollution Prevention Office (PPO). The results of the PPSD were analyzed by the PPO. Success stories were published in Division communications.

PPSD Results

Over 200 operations were reviewed during the PPSD by 154 teams encompassing a couple thousand employees. Table 1 provides the project breakdown by category.

POLLUTION PREVENTION		
PROJECT CATEGORY	NO. OF PROJECTS	% OF TOTAL
PAPER	96	44
HAZARDOUS MATERIALS/ HAZARDOUS WASTE	50	23
PACKAGING	15	7
WASTEWATER	4	2
OTHER	51	24
TOTAL	216	100

Table 1. Pollution Prevention Stand Down Project Summary

Table 2 compares the planned PPSD reductions with actual reductions achieved. Note: Packaging and Other product categories reductions were either negligible or did not lend themselves to the table format.

<u>WASTESTREAM</u>	<u>PROJECTED REDUCTION</u>	<u>ACTUAL REDUCTION</u>	<u>PERCENT REDUCTION</u>
PAPER	161,055 LBS	173,600 LBS	108
HAZARDOUS MATERIALS/WASTE	5,900 GALS	8,427 GALS	143
WASTEWATER	1.1 MILLION GALS	2.0 MILLION GALS	182

Table 2. Planned Reductions Versus Actual Reductions

Actual reductions notably exceeded PPSD projected reductions for paper, hazardous material/hazardous waste, and wastewater. This and the employees' positive feedback exemplified the enthusiasm with which the PPSD was executed and represents proof of its success. It also showed us that the PPSD was an effective educational tool.

Significant Accomplishments

Specific significant projects identified and implemented as part of Crane's PPSD include:

Elimination of two-part isocyanate foam. The foam generation process used by preservation and packing personnel at the Crane site was replaced with a paper pad machine. The installation and use of this equipment was expedited by the PPSD. The savings identified for this project is \$135,000 per year. Intangible benefits include the elimination of the use of toxic isocyanates. The procurement of 45,000 pounds per year of hazardous material was eliminated along with associated hazardous waste disposal costs.

Paper reduction. The PPSD resulted in fewer copies, more duplexing, greater use of e-mail and transfer and imaging systems, and more effective use of bulletin boards and automated directives/regulations systems. PPSD paper reduction amounted to over 80 tons the past year at a savings of \$66,000.

Water reduction. Two million gallons of water was saved as

a result of two PPSD initiatives which included tank overflow redesign and closed-looping a cooling system. Total savings from these projects are estimated at \$12,000.

Hexane waste reduction. Procedure revisions and enhanced personnel training in our pyrotechnics development processes resulted in the elimination of 110 gallons of spent hexane being sent to the Ammunition Burning Grounds for treatment.

1,1,1-trichloroethane elimination. The installation of an aqueous hot water parts washer was expedited as a result of the PPSD. It eliminated the procurement and usage of 4,000 gallons per year of 1,1,1-trichloroethane at an annual savings of \$30,522.

Toxic chemical elimination in Print Shop. The PPSD precipitated the following product substitutions in the print shop: perchloroethylene roller wash was replaced with a nonchlorinated material; a cyanide based printing press solution was replaced with a noncyanide product; methylene chloride deglazing compound was replaced with a nonchlorinated solvent; and oil-based inks were replaced with soy-based ones. Costs associated with substitutions were equivalent to original products, but intangible benefits in terms of toxics elimination include a better work environment and improved morale.

Summary

Pollution prevention saves money and resources and protects the environment (internal as well as external). It involves the consideration and application of waste elimination and reduction measures during the life cycle management of our products and services—from development, through processing, to ultimate disposition. The PPSD served as an important logistics tool in relaying this message to thousands of Crane employees through a bottom-up approach. It resulted in enhanced employee awareness and empowerment and tangible and intangible benefits for Crane and the US Navy.

Ms Andrews is presently Director, Pollution Prevention Office, Naval Surface Warfare Center, Crane Division, Crane Indiana.

(Continued from page 7)

challenge to find responsible assignments for LCBP officers when they come through an organization for only three to six months, but all are capable people, ready to work, and provide "free temporary labor." It only makes sense that the ALCs and the Air Force Materiel Command take full advantage of this resource.

Captain Roberts is presently a USAF Logistics Career Broadening staff officer at the Oklahoma City Air Logistics Center, Tinker AFB, Oklahoma.



Reutilization—A Logician's First Source of Supply

Joe Murphy

Introduction

Department of Defense (DOD) activities are saving millions of dollars every year through the Defense Reutilization and Marketing Service (DRMS) Reutilization Program. From routine requirements to specialized equipment, a wealth of excess, "ready-to-reuse" property is received daily by DRMS. By taking advantage of the DRMS Reutilization Program, DOD components can reduce procurement costs and eliminate unnecessary repairs.

The material is provided to DOD activities at **no cost** by DRMS, though some DOD accountable officers may impose a charge to end users. Almost every item in the military supply system can be found at a Defense Reutilization and Marketing Office (DRMO) at one time or another. Certain hazardous property, available commercially, is also available for reutilization. This includes paints, varnishes, oils, adhesives, cleaning compounds, and pesticides.

The military Services turn in excess property at DRMOs located on or near most US military facilities around the world. Property is being received at a volume that has not been seen since the end of World War II. In fiscal year 1994 (FY 94), DOD activities reutilized over \$2 billion in property—a 15% increase over 1993. In FY 95, \$2.3 billion in property was reutilized.

How to Find Out What Property is Available

You can find out what property is available by accessing the Interrogation Requirements Information System (IRIS), the latest advancement in automated screening. On-site screening of property at your local DRMO provides only a hint of the amount of property now available. By taking advantage of a computer and a modem, you can use IRIS to review property available worldwide. Items are listed on IRIS by National Stock Number (NSN), National Item Identification Number (NIIN), or an item's three or four digit Routing Identification Code (RIC). Within seconds, the location and quantity of a requested item will appear on screen. If you cannot access IRIS direct, you can request the data from a supporting DRMO. If you are uncertain which DRMO supports you, call the Reutilization HelpLine listed at the end of this article.

DRMS also has a home page which lists property available for reutilization on the Internet at: <http://131.87.1.51>. The database includes Local Stock Numbers (LSN) as well as NSNs, allowing customers to search by NIIN, Federal Supply Class (FSC), Federal Supply Group (FSG), or noun name. Searches can also be conducted by specific DRMO or geographic zone.

How to Requisition Property

Property can be requisitioned through the Military Standard Requisitioning and Issue Procedures (MILSTRIP) system. The most efficient way for you to order is to "toggle" directly from IRIS into the new automated MILSTRIP ordering program. This allows

you to screen and order by simply making a few keystrokes. Prior to using this new ordering capability, however, current IRIS users must apply to DRMS for access to this MILSTRIP program. The Automated Digital Network (AUTODIN) can also be used to requisition property, via the Defense Automated Addressing System (DASS). If AUTODIN is unavailable, you can phone or mail a request to your supporting DRMO. When requisitioning, request a specific asset, identified by NSN and Disposal Turn-In Document (available through IRIS), or request a given NSN, and use IRIS to select a specific asset, based upon a predetermined condition or location.

In the past, DOD activities were given first priority for issue of DRMS assets. Under revised disposal procedures, property is now issued to DOD, non-DOD federal agencies, and certain state drug enforcement or treatment programs on a "first-come, first-served" basis. This means that requisitioning actions should begin immediately after screening.

Contractor Inventory Redistribution System

Through the Contractor Inventory Redistribution System (CIRS), reuseable property that is no longer needed by DOD contractors is made available for redistribution. Most material is new. Though the property is free, you will usually have to pay the packaging and transportation costs. You can request to be added to the CIRS mailing list by calling DSN 932-7288 or (616) 961-7288. The fax number is extension 5841.

Conclusion

DRMS is an important member of the Defense Logistics Agency team. Headquartered in Battle Creek, Michigan, DRMS has nearly 200 field offices located in 44 states and 20 foreign countries. Though the primary mission of DRMS is to reutilize property within DOD, DRMS also transfers property to other federal agencies. If an item cannot be reutilized or transferred, it may be donated to state and local agencies, or qualified nonprofit agencies, through the General Services Administration donation program. Property is also provided to DOD's Humanitarian Assistance Program and the State Department's Foreign Military Sales Program. If property cannot be reutilized, transferred, or donated, the property is sold. Revenues generated from the sale of surplus property not only finance DRMS's operating costs, but provide a significant return to the taxpayer for investments made in the national defense.

For information on any aspect of the DRMS Reutilization program, call the Reutilization HelpLine: 1-800-DRMS-RTD, (1-800-376-7783).

Mr Murphy is presently a public affairs specialist for the Defense Reutilization and Marketing Service Office of Public Affairs, Battle Creek, Michigan.



Environmental News

1996 Defense Logistics Agency Environmental Products Catalog

Catalog is Available Electronically

While we wait for our hard copies to arrive in the mail from the printer, you can browse the new catalog and even submit requisitions if you have access to the Internet's World Wide Web. Defense Supply Center Richmond (DSCR) produces the Environmental Products Catalog and has placed the database on its home page on the World Wide Web. The address is <http://www.dscr.dla.mil>. The catalog will also be on the Environmental Protection Agency's "EnviroSense" electronic bulletin board which can be accessed via the Internet or a dial-up bulletin board system (BBS) version.

500 Items in Catalog

DSCR continues to search out new, innovative products to include in the catalog. Industry, military, and federal civilian customers have provided numerous leads over the past year and have helped to expand the catalog to its current size of almost 500 national stock numbers (NSNs) split between 15 product

categories. Some of the new product categories include petroleum, oils and lubricants, pest management products, and natural resource conservation products.

1996 Catalog Has More Useful Information

As in the first edition, the catalog contains information on how to order, a description of the Department of Defense Hazardous Technical Information Service (HTIS), a key to chemical abbreviations, and useful phone and fax numbers. In addition, the new catalog contains e-mail addresses, the address for DSCR's home page on the World Wide Web, a centralized phone number for new product suggestions, and extensive points of contact information for each Defense Logistics Agency supply center. The environmentally-oriented commodities managed by each supply center are also shown so customers can easily determine which supply center they need to contact.

Stephen J. Perez
Program Executive
Marketing Office
Defense Supply Center Richmond
Richmond, Virginia

Save Landfill Space and Money, Too

Reduce Solid Waste Volume

Executive Order 12873, "Federal Acquisition, Recycling & Waste Prevention," 20 October 1993, requires all of us to reduce the volume of waste we generate in part by procuring recycled products whenever practical. The Defense Logistics Agency's (DLA's) Defense Supply Center Richmond (DSCR) can help you meet the goals of Executive Order 12873 by supplying your activity with remanufactured laser printer toner cartridges which are made to an exacting purchase description. These remanufactured toners are warranted to produce copies equal to or better than those produced by the original equipment manufacturer cartridges. In addition, the vendor warrants that these toners will not damage laser printers when properly used and will bear the costs of service or repair if a remanufactured toner causes such damage.

Significant Price Reduction for FY96

Prices of the five types of toner cartridges carried by DSCR have **lowered** an average of 46% from last year. The national stock numbers (NSNs), prices, and percent price reduction from last year are shown below:

NSN	Printer Type	Price
6850-01-216-6823 TYPE I (EP)	Canon CX engine	\$50.59 (36% reduction)
6850-01-261-6064 TYPE II (EP-S)	Canon SX engine	\$26.85 (63% reduction)
6850-01-343-6998 TYPE III (HISI/TVSi)	Canon NX engine	\$61.44 (14% reduction)
6850-01-376-1766 TYPE IV (LaserJet 4)	Canon EX engine	\$79.93 (55% reduction)
6850-01-321-0640 TYPE V (EP-L)	Canon LX engine	\$38.56 (40% reduction)

Quality and Delivery

DSCR's purchase description 6850-1A dated 13 April 1994, ensures you get a remanufactured laser printer toner cartridge that equals or betters the performance of the original equipment. Each toner comes with a United Parcel Service (UPS) label which allows you to send the spent cartridge back to the manufacturer. You don't add to your installation's solid waste disposal headaches and the return mailing is free.

Innovative contracting techniques are being used to make toners and other DSCR products more readily available to our military and federal civilian customers. Easy Military Standard Requisitioning and Issue Procedures (MILSTRIP) or Federal Standard Requisitioning and Issue Procedures (FEDSTRIP) requisitioning, the high quality, and the low prices all make for DSCR and the supply system to be your logical choice for remanufactured laser printer toner cartridges and many other items.

If you have technical questions, call Clifford Myers at DSN 695-6054 or commercial (804) 279-6054. If you have supply questions, call Ann Weaver at DSN 695-6054 or commercial (804) 279-6054. If you want to place an order or need any other kind of assistance, call DSCR's Marketing Office at DSN 695-5699 or commercial (800) 352-2852.

Stephen J. Perez
Program Executive
Marketing Office
Defense Supply Center, Richmond
Richmond, Virginia

Those Oh So Vulnerable Lines of Communication

Lieutenant Bart A. Vinskey, SC, USN

Early on the morning of September 22, 1914, three Royal Navy cruisers steaming on a steady course and at a speed of ten knots were sighted by the German U-boat, *U-9*, commanded by Lieutenant Commander Otto Weddigen. Captain Weddigen quickly prepared *U-9* for an attack. He also set in motion processes that would eventually see the German High Command turn the wrath of its armed forces directly against its enemies lines of communication in an effort to starve both populations and industries into submission. Industrialized economies were soon to discover that their armies, navies, and emerging air forces were extremely vulnerable hundreds and thousands of miles away from any known traditional battlefields.

U-9 positioned herself abeam of the cruiser formation and shot two torpedoes at the lead ship of the British column, the *Aboukir*. Both weapons struck home and the *Aboukir* began to sink. Initially, the ships accompanying *Aboukir* believed she had struck a mine. They soon realized their mistake when they saw that *Aboukir* had hoisted the signal for submarine attack. Despite this warning, however, they proceeded with their rescue operation, believing that they could avoid attack from the U-boat. They were wrong and soon the Royal Navy cruisers *Cressy* and *Hogue* joined *Aboukir* on the bottom of the North Sea. *U-9* and her crew had ushered in a new form of warfare that would forever change how wars were fought.

Following this successful action by *U-9*, many members of the German Naval Staff began to speak of countering the British blockade of Germany with a U-boat blockade of Great Britain. At the beginning of World War I, Great Britain declared a blockade of Germany giving her the right, under international law, to intercept and destroy German passenger or cargo vessels. The Royal Navy vessels enforcing the blockade were required to ensure the safety of the passengers and crews of these vessels. In addition, the British were allowed to "visit and search" vessels flying the flags of neutral nations to ensure that they were not enemy vessels flying false flags. The Germans did not have the naval strength to break the blockade and they could not gather enough international support to break it politically. The U-boats seemed to offer an option. The biggest difficulty in using U-boats for blockading was that they could not "visit and search" without exposing themselves to risk of damage or sinking. U-boats also could not provide for passengers and crews of the ships they might sink. The debate raged and the decision was finally made to attempt a U-boat blockade of Great Britain.

On February 4, 1915, Germany announced the existence of a "war zone" around the whole of the British Isles. All hostile ships found in this area would be destroyed. Neutrals would not be intentionally attacked, however, they would sail the area at their own risk. Phase One of the U-boat campaign was unsuccessful, claiming only 33 ships for a total of 100,000 tons in three months.

It was during Phase One of the campaign that *Lusitania* was sunk. The Kaiser, bowing to international pressure, imposed harsh restrictions on how U-boats conducted their operations. These restrictions forced the German Naval Staff to end the first U-boat campaign.

In early 1916, the German Naval Staff urged a resumption of the U-boat campaign. They argued that the British blockade of Germany and the lack of success in the ground war could only be solved by knocking Great Britain out of the war and that the way to do that was by U-boat blockade. Starve the British people of food, British industries of raw materials, and the British military of war fighting materials and Germany could win the war. The Kaiser reluctantly granted permission, and in March of 1916 the U-boats began an unrestricted campaign against Great Britain. Phase Two, however, ended like Phase One. The U-boats unrestricted campaign aroused worldwide moral indignation. The Kaiser once again gave in to this international pressure and ordered a halt to the U-boat campaign.

In early 1917, the German Naval Staff once more began to pressure the Kaiser to lift his restrictions on U-boat operations. They continued to see the U-boat offensive as the best way to eliminate Great Britain from the war. The Kaiser agreed and ordered the Navy to blockade Great Britain. He even went so far as to order the entire High Seas Fleet to concentrate its operations in support of the U-boat campaign. The Kaiser explained that "to us every U-boat is of such importance that it is worth using the whole available fleet to afford it assistance and support." (1:21) Phase Three almost turned the tide for the Germans. In the first three months of the phase, German U-boats sank 1,000 ships of approximately two million tons!

Initially, the British did not consider the U-boat a true threat. It was slow, had limited endurance, and was not well armed. This attitude began to change rapidly following the loss of *Aboukir*, *Cressy*, and *Hogue*. The U-boat had demonstrated its ability to strike major naval units **at sea**. Up until that time the major concern had been that U-boats would penetrate fleet anchorages and cause havoc among anchored and moored shipping. It came as a real shock that the U-boat was an effective man o'war. What was even more upsetting to the British was that their only defense against U-boats seemed to be avoidance. Fleet practice was to **ram** submarines caught on or near the surface. As the war progressed, the Royal Navy worked hard to develop solutions to the U-boat threat. The British relied very much on the use of radio intelligence and direction finding to locate U-boats and maneuver around them or to ambush them.

British scientists developed the hydrophone, a passive acoustic detection device that enabled them to detect submerged submarines. The development of the depth charge provided the Royal Navy a weapon with which they could attack submerged

submarines. No longer would a ship have to take the risk of ramming a U-boat. They now only had to drive over a suspected U-boat and drop depth charges.

The most effective technique developed to neutralize the U-boat, however, was not weapon based. It was the convoy system. The convoy system assembled the merchant ships into large formations for crossing the Atlantic. These formations were heavily escorted and, through the use of radio intelligence, were quite effectively "steered" around known U-boat concentrations. When U-boats did make contact with a convoy, they were forced to deal with the depth charge-armed escort vessels before they could engage the merchant ships. The effectiveness of the convoy system is best seen in the loss statistics for 1918: 1,133 ships lost, 999 sailing alone and 134 sailing in convoys. (1:24)

At the outbreak of World War I, the submarine was considered a coastal defense weapon and scout, adaptable to the role of assaulting harbors and anchorages. It quickly became obvious that the submarine was a much more useful platform than expected. During the course of World War I, German U-boats sank 10 battleships, 18 cruisers, 21 destroyers, and 5,708 merchant ships totaling 11 million tons. (1:24)

Germany and Great Britain entered World War I, believing in the supremacy of the battleship and in the Mahanian concept of the single decisive battle. Neither side envisioned what actually occurred. The great fleets of battleships never engaged in the single decisive battle. As things turned out, the single decisive battle was the Battle of the Atlantic and it was fought most ferociously from February 1917 to the end of the war. This battle pitted, not battleship against battleship, but U-boat against

destroyer and merchant ship. Germany came very close to taking Great Britain out of World War I, not by any great victory on the battlefield, but by nearly severing Great Britain's lifeline to the world; by destroying her logistics system at its very source. The ultimate irony is that this same logistics system is what provided the Royal Navy with the key instruments of the U-boats' defeat: the hydrophone equipped, depth charge-armed destroyer and the convoy system.

The question we need to be concerned with today is what surprises are in store for us? In our next conflict how will our enemy behave? Will he adapt old weapons to new missions? Will he be innovative in his operational thinking? How will his actions impact our own operations? The United States relies overwhelmingly on exterior lines of communication. Will our future enemies attempt to interdict these lines of communication, and, if they do so, how will we react? Logistics is the **keystone** of modern combat operations. It is also one of the weakest links in our national defense chain. Should an enemy launch a direct attack on our lines of communication, would we expect it, or would we, like the Allies of 1917, be totally unprepared for the onslaught?

References

1. Blair, Clay. *Silent Victory: The US Submarine War Against Japan*, NY: Lippincott, 1975.

Lieutenant Vinskey is presently Director, Combat Logistics Course, Air Force Institute of Technology, Wright-Patterson AFB, Ohio. 

SOLE '96

**Society of Logistics Engineers 31st Annual International
Logistics Conference and Exposition
Hyatt Regency, Crystal City, Virginia
27-29 August 1996**

"Logistics, the Future is Now!"

Welcome to the 21st century in logistics. The Greater Washington Area Chapter will host SOLE's 31st Annual International Logistics Conference and Exposition to set the stage for launching logistics technology into the 21st century.

The program is designed to offer insight and commentary from recognized logistics experts through tutorials, plenary sessions, and challenging technical session tracks. The technical program will incorporate the SOLE '96 concept of the 21st century logistician through concentration in the areas of Systems Integration, Design Distribution & Support, and Supply-Chain Management.

SOLE '96 will emphasize the commercial sector as well as military logistics and the international community and US representation. Special attention will also be given to emergent issues such as environmental logistics.

For more information call Commander Jon Sherman at (703) 614-4157 or Captain Cheryl Allen at (703) 604-2440.

Systematic Readiness Engineering Analysis: Converting Modern Mythology Into Future Reality

William Jones, Jr.
Deborah S. Motz

Introduction

There have been extensive changes in the world of government acquisition. The impacts of reduced manpower (both military and civilian), the limitations of new weapon system acquisitions, the reorganization and closures of defense activities, the changing industrial base, the curtailment in the use of military standards (MIL-STDs) and military specifications (MIL-SPECs), and the ever decreasing defense dollar have created opportunities for logisticians to provide supportability without loss of quality or system degradation. This ability to provide logistics support has become a challenge in both the military and civilian sectors. Industry's need to produce reliable products with minimally funded logistics inputs has become common place. The time for using multiple management tools that can be contradictory, cumbersome, and costly has passed. Logistics applications that try to incorporate integration must truly be integrated at the inception of any acquisition. Therefore, producing logistics readiness up front should be the goal of every engineer, logistician, and manufacturer. The purpose of this paper is to propose a methodology and make a case for integrating existing stand-alone logistics processes and computer models beginning at the outset of the system design process.

To understand the management concept behind Systematic Readiness Engineering Analysis (SREA), we must first look at current processes related to both systems readiness and logistics readiness. Systems Engineering (SE), Continuous Acquisition and Life-Cycle Support (CALs), Concurrent Engineering (CE), Total Quality (TQ), Logistics Support Analysis (LSA), and Integrated Logistics Support (ILS) are all processes that have valid attributes. Each process contributes valuable information to the acquisition process. However, most of these processes are being implemented as "stand-alone" utilities rather than an interactive process. SREA will combine these processes into an effective and economical analysis and management tool. To understand this concept, we will first reiterate each processes' role and show the inherent benefits of the SREA philosophy.

Modern Mythology

In looking at each process (SE, CALs, CE, TQ, LSA, and ILS), it can be seen that there are many advantages in their use with respect to program performance. The implementation of each process can be seen as a segment of a much larger process. However, the reality of implementing these applications has been counterproductive because of redundancies and contradictions. Let us examine the attributes of each of these processes and the pitfalls associated with the implementation of each process in a

"stand-alone" mode.

Since the publication of the Department of Defense Directive (DODD) 5000.39, *Acquisition and Management of ILS for Systems and Equipment* in November 1983, the use of system readiness parameters have gained importance. These parameters have allowed the program manager to set objectives for such things as design, acquisition, and logistics simply because they can be measured mathematically (Figure 1).

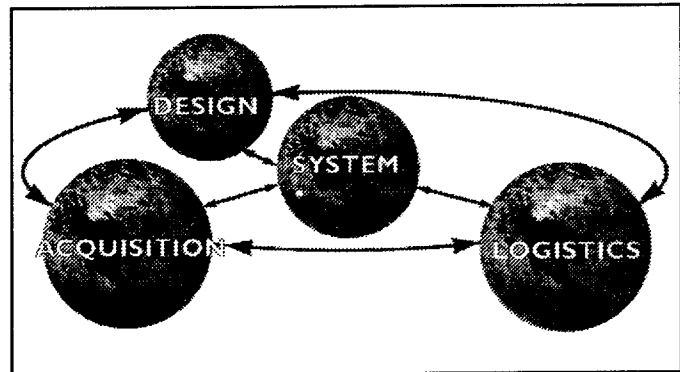

Figure 1. Current Systems Development Process

Probably the most well-known system readiness parameter is Operational Availability (Ao). It is frequently used for both wartime and peacetime by the United States Department of Defense (DOD), and it is increasingly being used in the commercial sector as needs similar to those of defense arise more frequently. The most commonly used definition of Ao is shown in Equation 1.

$$Ao = \frac{\text{Uptime}}{\text{Total Time}} = \frac{\text{MTBF}}{\text{MTBF} + \text{MTTR} + \text{MLDT}}$$

$$\text{where MLDT} = \frac{\text{MTBF}}{Ao} - (\text{MTBF} + \text{MTTR})$$

Ao = Operational Availability
MTBF = Mean Time Between Failures
MTTR = Mean Time To Repair
MLDT = Mean Logistics Delay Time

Equation 1. Operational Availability

As seen above, Ao is an indicator of the capability designed into the system (MTTR and MTBF). The problem that is encountered is that the Ao is often used to measure Logistics Readiness (MLDT) versus the inherent design capability of the

system. While logistics is a part of the operational availability as it relates to systems readiness, it should not be used as an indicator of design reliability.

Systems Engineering (SE)

The complications of management of the design, development, production, and fielding of complex items have resulted in the development of the Systems Engineering process. Systems engineering has been defined to include those scientific and engineering efforts to:

- (1) Transform an operational need into a description of system performance parameters and a preferred system configuration through the use of an interactive process of functional analysis, synthesis, optimization, definition, design, test, and evaluation.
- (2) Integrate related technical parameters and ensure compatibility of all physical, functional, and program interfaces in a manner that optimizes the total system definition and design.
- (3) Integrate reliability, maintainability, logistics support, human factors, safety, security, structural integrity, producibility, and other related specialties into the total engineering effort. (3:21)

The SE process, and its evolution of functional detail and system design requirements, has as its goal, the achievement of the proper balance between operational systems readiness, economic affordability, and logistics readiness factors. The process employs a sequential and iterative methodology to reach cost-effective solutions. The information developed through this process is used to plan and integrate the engineering effort for the system as a whole. Figure 2 illustrates the steps of this process.

Systems Engineering is not necessarily new, but is supposed to be a process with emphasis on a "top-down" approach, looking

at the system as a whole. Emphasis should be placed on the "life-cycle" support aspect with an "interdisciplinary" or "team" approach to design and development. A pitfall of this process is the emphasis on its sequential approach to achieving the *balance* between systems readiness, cost, and logistics readiness. As these factors change, there is no reliable mechanism in place to make the necessary adjustments in maintaining this *balance*.

Continuous Acquisition and Life-Cycle Support (CALS)

Continuous Acquisition and Life-Cycle Support, formerly known as Computer-aided Acquisition and Logistics Support, is a strategic initiative to move from paper-driven islands of automation to an interactive digital environment.

Initiated in 1985, the CALS initiative is an example of management's response to general trends in technological advances of information engineering. The DOD motivating factors include the current defense restructuring, the shrinking budgets, better information quality, shorter lead times, and lower costs. The commercial motivation is to meet global competition through better quality, shorter lead times, and lower costs by exploitation of integrated information technologies in terms of enterprise integration and trading partners. Figure 3 (next page) shows the planned transition from islands of information to the ultimate objective of an integrated weapon systems database. The major focus of CALS has been on technical information automation, integration, interactive/on-line access, and digital delivery. A few of the pitfalls associated with this transition are:

- (1) Automation for the sake of automation does not improve the process.
- (2) Shrinking defense dollars have hampered the smooth transition between the phases of CALS implementation.
- (3) There has been such an emphasis placed on developing

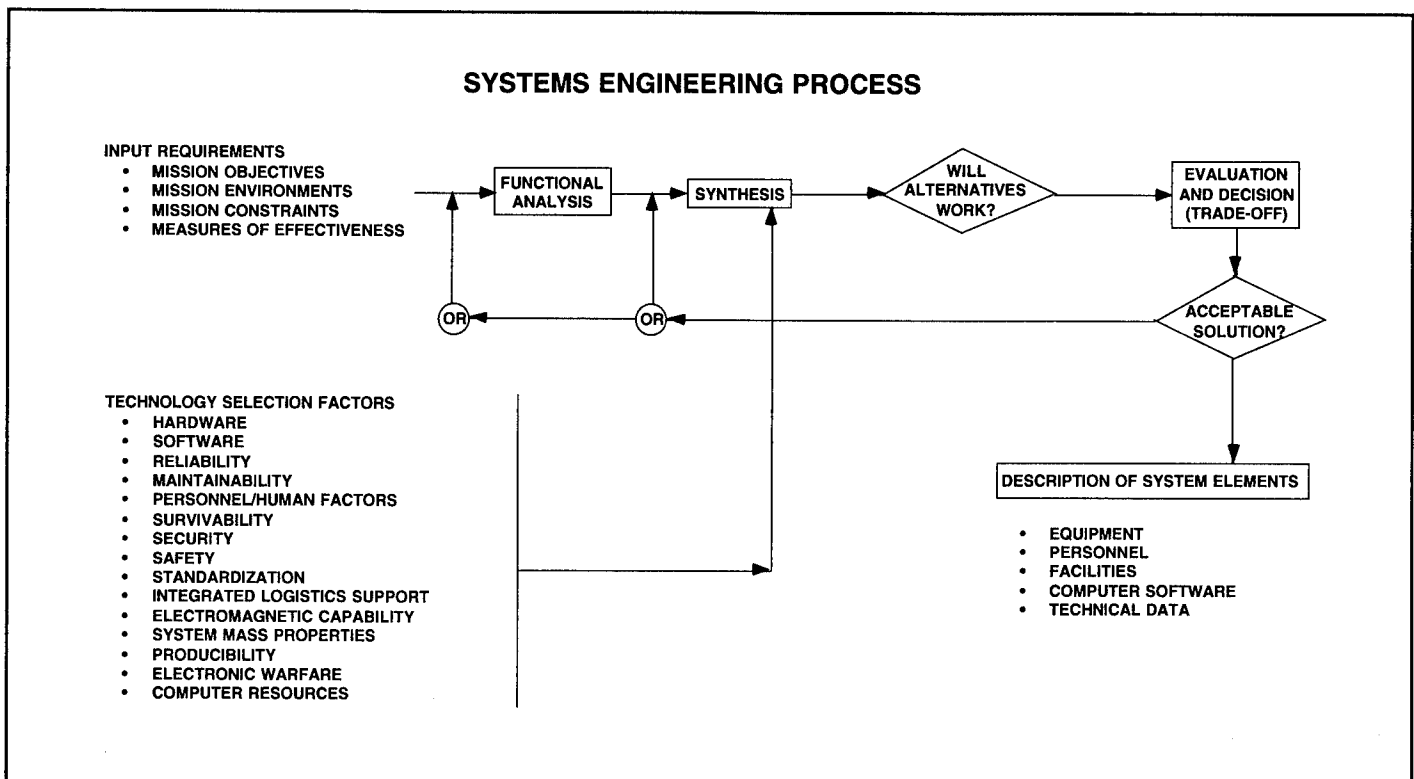

Figure 2. The Systems Engineering Process (3)

CALS TRANSITION

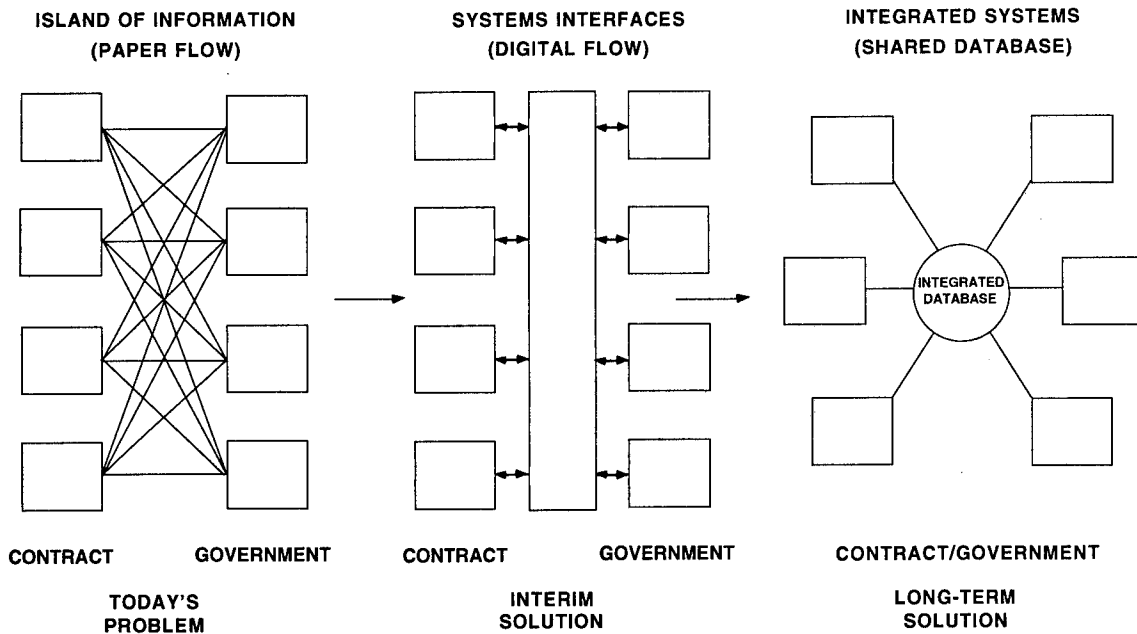

Figure 3. Continuous Acquisition and Life-Cycle Support Transition

standards that technology has already surpassed the standards being implemented.

(4) There is no agreement on what information quality should be.

(5) There is no mechanism in place to allow the small business owner to compete in this environment.

Concurrent Engineering (CE)

Concurrent Engineering is a systematic approach to the integrated, concurrent design of products and their related processes, including manufacture and support. This approach was intended to ensure management and engineering consideration of product and process design integration from the beginning of the program. Consideration is given to all elements of the product life cycle, including quality, cost, schedule, and user requirements.

Like CALS, CE is being employed in the government as well as the commercial sector. Figure 4 illustrates the comparison between sequential and Concurrent Engineering.

The pitfalls associated with CE include the lack of the technological and organizational changes needed for an interactive information flow. Secondly, CE efforts must be led to be effective since most people place too much emphasis on the techniques used (Statistical Process Control, Quality For Design, Design of Experiments, etc.) and not enough on the critical management philosophy underlying the application of the techniques. While the use of interdisciplinary teams is encouraged, at times, the reality of the contractual arrangements prohibits the actual interaction at the organizational levels needed to effect cost savings, quality improvements, and design changes while the system is under development. Continuous improvement is stifled and production is decoupled from design.

Total Quality (TQ)

As the acquisition environment changes, and as global industrialization and competition increase, there is growing recognition of the need for higher quality and user satisfaction. Total Quality is both a philosophy and a set of guiding principles that represent the foundation of a continuously improving organization. A typical TQ model for continuous improvement is shown in Figure 5.

TQ is the application of quantitative methods and human resources to improve the material and services supplied to an organization, all the processes within an organization, and the degree to which the needs of the customer is met, now and in the future. TQ integrates fundamental management techniques, existing improvement efforts, and technical tools under a

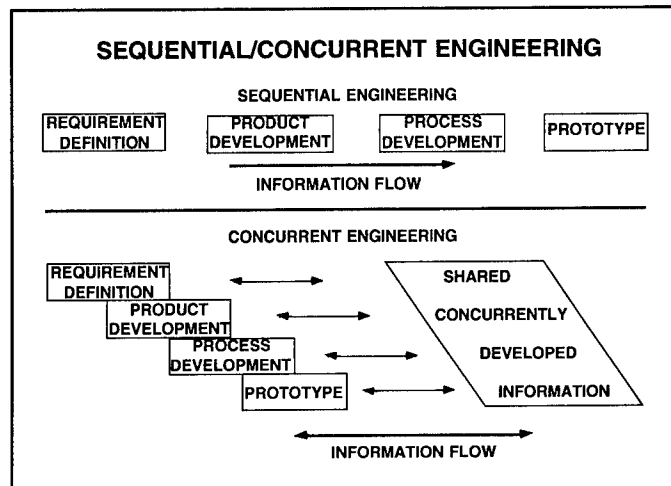

Figure 4. Sequential Engineering Versus Concurrent Engineering

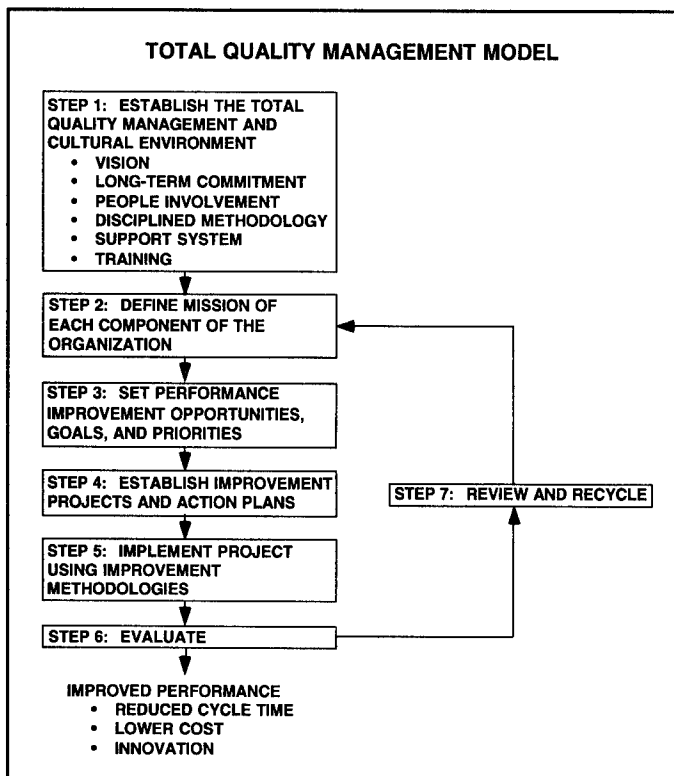

Figure 5. Typical Total Quality Management Model

disciplined approach focused on continuous improvement. It is obvious from this explanation that Total Quality is a management process that can involve everyone in the organization, from the highest to the lowest levels. In fact, TQ emphasizes the active involvement of top management. Let's face it, TQ is not new. That is, the components and concepts of TQ are not, by themselves, new. They are based on fundamentals of management and business. The major pitfalls of this philosophy are:

- (1) The lack of "buy-in" by management.
- (2) The lack of proper communication.
- (3) The lack of proper training in the use of the TQ analytical techniques.

Each of these "lacks" impact on the performance, cost, schedule, and use of technology during the life cycle of the system.

Logistics Support Analysis (LSA)

Logistics Support Analysis is defined as a selective application of scientific and engineering efforts undertaken during the acquisition process as part of the Systems Engineering and design process to assist in complying with supportability and other integrated logistics support objectives. (14:36) LSA constitutes the integration and application of various techniques and functions to ensure supportability requirements are considered in the system design process. LSA is a process employed on an iterative basis throughout system design and development. The LSA process is a planned series of activities to examine all elements of proposed product support to prevent duplication of logistics efforts and to ensure commonality and integration of logistics support. This process is intended to influence the design so both the product and its support can be provided at an affordable cost.

It involves the utilization of different analytical methods to solve a wide variety of problems, and its depth of application is tailored to meet specific program needs. Figure 6 (next page) shows the flow of LSA steps without regard to complex interrelationships.

Some of the major pitfalls associated with the LSA process include issues of timing, training, and data integrity. Difficulties have arisen when LSA implementation occurs too late to influence design or when management has inadequately addressed front-end LSA requirements analysis which has resulted in inadequate tailoring of the LSA effort. Lack of readily available training on the LSA process has hampered the process and has contributed to the lack of proper communication. LSA documentation has been maintained throughout a system's life cycle on a "static" versus a "dynamic" basis. This is based on the inflexibility of LSA applications resulting in a lack of proper documentation of LSA data which is reflected in the lack of a proper audit trail.

Integrated Logistics Support (ILS)

Integrated Logistics Support is the disciplined and unified management of the technical logistics disciplines that plan, develop, and implement supportability requirements throughout a system's life cycle. Table 1 lists the ILS elements.

ILS ELEMENTS
MAINTENANCE PLANNING
MANPOWER AND PERSONNEL
SUPPLY SUPPORT
SUPPORT EQUIPMENT
TECHNICAL DATA
TRAINING AND TRAINING SUPPORT
PACKAGING, HANDLING, STORAGE, AND TRANSPORTATION
COMPUTER RESOURCES
DESIGN INTERFACE
FACILITIES

Table 1. Integrated Logistics Support Elements

One of the major pitfalls associated with ILS is that the elements are "stovepiped" rather than integrated. This means each element is implemented and functions independently of the others. This "stovepiping" is caused to some extent by the organizational structure. Historically, people became subject matter experts in their field and provided technical expertise in their particular area. As functions move from activity to activity, downsizing efforts result in funding decreases and early retirements and reductions in force. These changes result in a decrease of the experience level and knowledge base of the available subject matter expert pool. Another area that has created concern is the lack of early involvement of the ILS organization in the acquisition process. This causes the ILS organization to play "catch-up" in order to meet program deadlines and user requirements. At times, there is a redundancy problem associated with level of effort and documentation; while at other times, the organizational structure inhibits integration of the ILS disciplines. Finally, there is no adequate mechanism in place to calculate logistics costs up front. This creates a constant challenge for the ILS manager in supplying logistics support.

LOGISTICS SUPPORT ANALYSIS FLOW

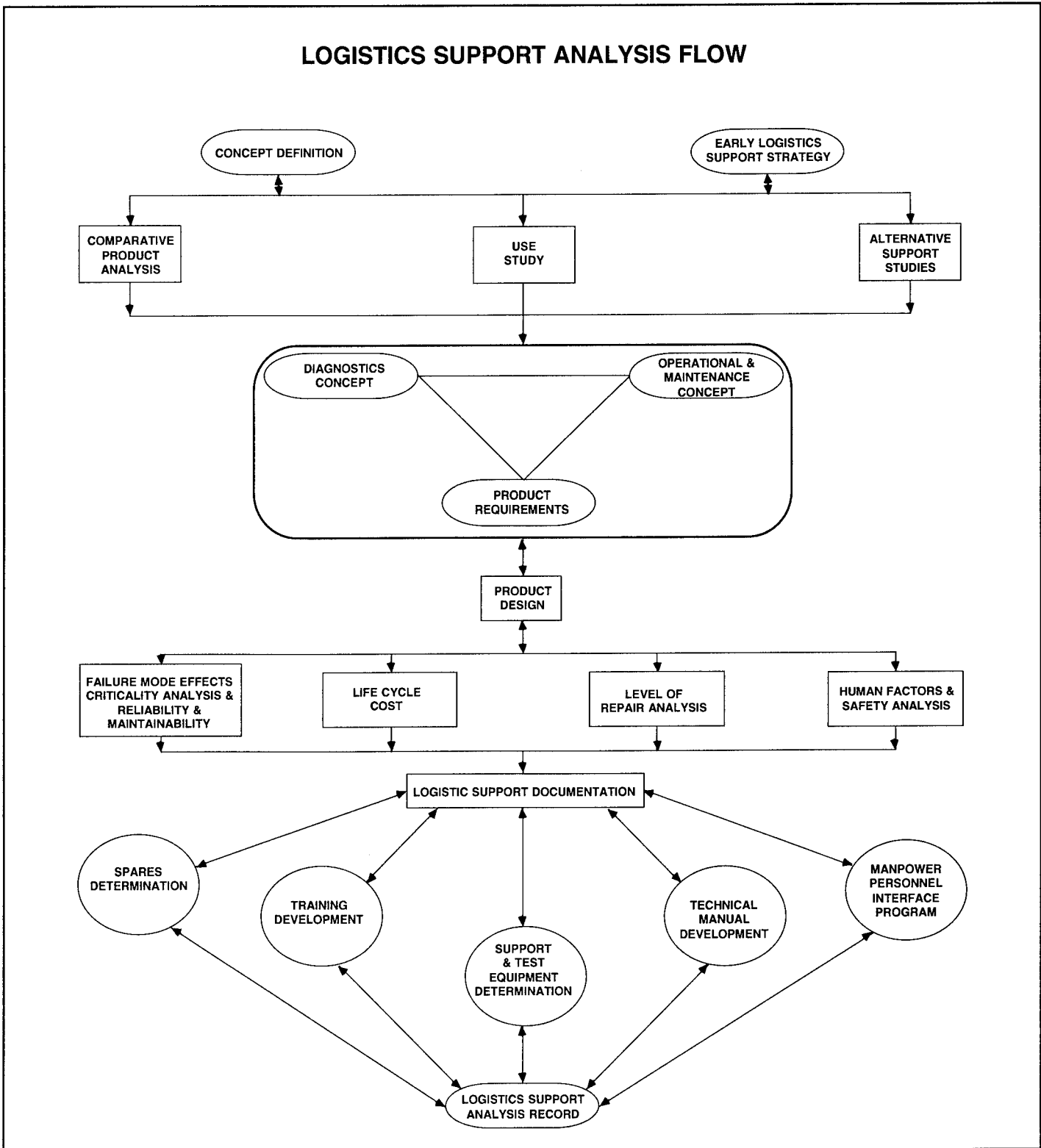

Figure 6. Logistics Support Analysis Flow

Future Reality

Systematic Readiness Engineering Analysis (SREA) combines the principles of SE, CALS, CE, TQ, LSA, and ILS into an integrated systematized process. It would eliminate the pitfalls associated with each of these initiatives previously identified. SREA would in effect generate the technical data necessary to produce the engineering and logistics products necessary to

increase the logistics readiness of the system or equipment under analysis. SREA would eliminate the requirement for all of the separate “stovepipe” engineering and logistics analyses. It would be flexible enough to allow analysis to be conducted on any type of acquisition. SREA would require the initiation of multidisciplinary SREA teams. The multidisciplinary SREA teams would be made up of individuals from the following engineering and logistics communities. This list is **not** all inclusive:

- End User
- Design
- Reliability
- Maintainability
- Availability
- Human Factors Engineering
- Logistics Engineering
- Supportability
- Producibility
- Manufacturing
- Supply Support
- Personnel from all of the remaining Integrated Logistics Support disciplines

The SREA team would conduct studies or analyses aimed at influencing the design of the system or the design of the support functions of the system, or both, depending upon what phase in the product life cycle the SREA process was initiated. This is a portion of the flexibility that was spoken of earlier. In this type of environment, the parameters utilized in calculating the logistics readiness of the system under analysis would vary dependent upon the phase of the product life cycle and/or the type of acquisition under which the system was developed and procured. Supportability parameters would be considered throughout the SREA process, unlike what had been accomplished in the past, because technology would allow imbedding those parameters into the SREA workstation we will describe a little later in this section.

SREA would define the processes and procedures needed to increase logistics readiness. The SREA process would also define what needs to be accomplished, both in the early stage of product concept development and in the post product development stage, to properly define, determine, implement, and perpetuate the logistics readiness for the entire system life cycle.

The SREA process would serve as the catalyst to initiate the flow of information from a single distributed integrated database, which would be used to evaluate the sensitivity of changing the various logistics readiness parameters of the system. This would be useful in determining the criteria for the life-cycle maintenance of the system's logistics readiness (sparing models, changing mission scenarios, cost consideration, etc.). This information would reside in the integrated SREA distributed database environment, which includes all engineering and logistics data for the system. The goal of SREA is to provide 100% logistics readiness, with minimal cost, information degradation, and system downtime.

In looking at the current practice of integrating design, acquisition, and logistics for system development, it became apparent that system readiness and logistic readiness could not be adequately addressed by utilizing the same methods (Figure 7). As the system and logistics are treated as separate entities, so should their readiness indicators.

As seen in Figure 8, system readiness is affected by the design and manufacturing community, and is basically a concurrent engineering function. It should be directly tied to the inherent availability designed into the system. In assessing system readiness, we should be looking at such questions as:

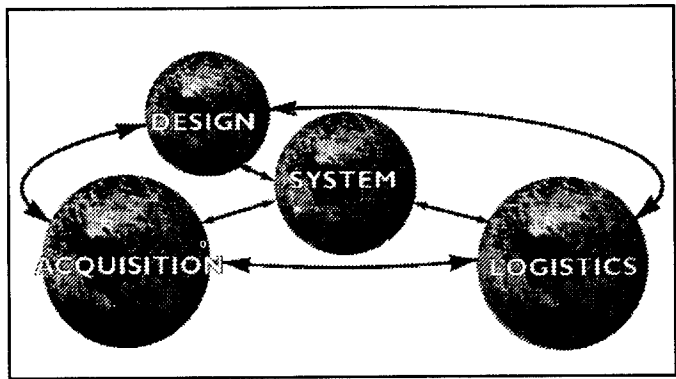

Figure 7. Current Systems Development Process

- (1) Does the system do what it was advertised to do?
- (2) Is the system reliable?
- (3) Can the system be repaired?
- (4) Can the system be produced?

After assessing system performance, manufacturing resource availability, and system reliability, the logistics of getting the user trained, supplied, and supported comes into play.

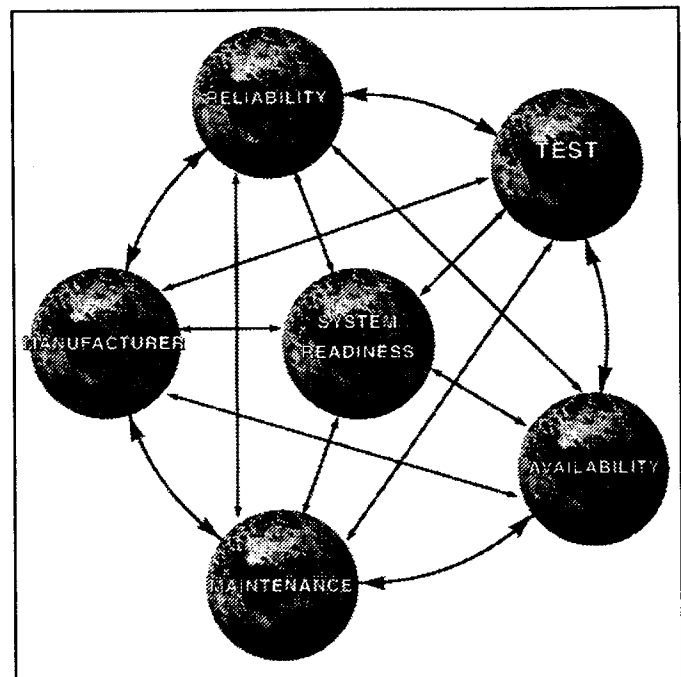

Figure 8. System Readiness

In Figure 9 (next page), logistics readiness can be seen to be impacted not only by the system's engineering process, but by cost, time, and life-cycle considerations as well. This is the point where we should be looking at such questions as:

- (1) How will we support the system?
- (2) Who is doing the maintenance for this system?
- (3) Where will we store technical data, or repair parts, or support equipment?
- (4) What types of data, or parts mix, or computer resources are required?
- (5) When does the user need the support?

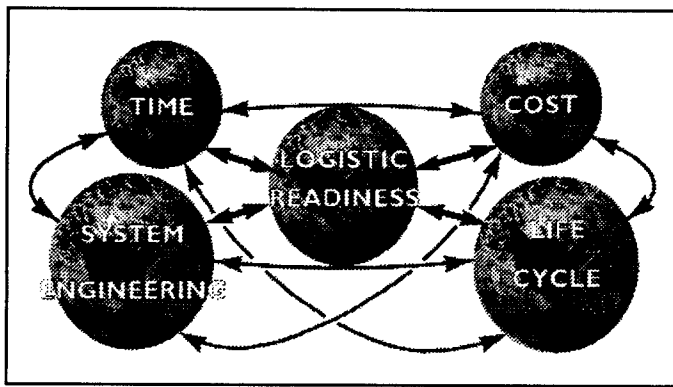

Figure 9. Logistics Readiness

Who, what, where, when, how, and why seem to be prevalent in any logistician's vocabulary. In answering these questions and incorporating the life-cycle considerations of any system acquisition, the logistician is actually building a logistics "network" that will evolve into total support for the system.

SREA will be able to measure this "network" on a consistent basis, and will take the system through the acquisition phases incorporating both the system readiness inputs with the logistics readiness inputs. This will create a "bridge" between acquisition logistics and operational logistics which will facilitate a comprehensive life-cycle model for the system (Figure 10).

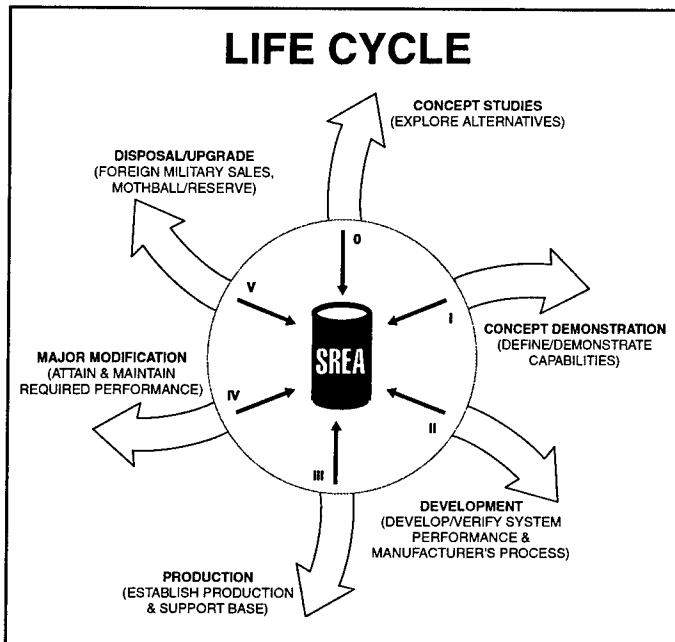

Figure 10. Comprehensive Life-Cycle Model

The basic concept behind the Systematic Readiness Engineering Analysis is to incorporate the inputs from the processes in use today into a single, front-end workstation. By integrating the applications, the pitfalls of each of the processes would be minimized and the benefits would encourage reductions in information redundancy, cost, manpower, and time.

Referring back to Figure 9, if we want to look at measuring logistics readiness, we can extrapolate the chart into the following equation:

$$\text{LOGISTICS READINESS} = f(T) + f(\$) + f(SE) + f(\text{LIFECYCLE})$$

T = Total Program Time

\$ = Total Program Cost

SE = Systems Engineering Parameters

LIFECYCLE = Logistics Considerations

Equation 2. Logistics Readiness

This equation is a generic look at what comprises logistics readiness. The program manager will be able to determine the weight associated with each parameter in the equation on the basis of such things as acquisition type, acquisition phase, continuous threat assessment, technological advantages, multi-Service applications, budgetary changes, etc. As considerations change throughout the life cycle, so too can the SREA. In the SREA concept, as the program progresses and data is continually fed into the work station, impacts to logistics readiness could be measured as circumstances dictate. SREA will provide an economical, user-friendly management tool for the manufacturer, logistician, and engineer.

The SREA Environment

Given that design in the modern world is conducted predominately in a computer-aided environment, numerous commercial computer-based logistics models and tools have been developed to aid the system design process. Unfortunately, most commercially available computer-based tools operate on a stand-alone basis. The basic concept behind SREA is to integrate these stand-alone tools and logistics computer models (Figure 11).

An integrated computer-based logistics analysis environment can contribute significantly towards the development of an effective, efficient, and easily supportable system. Moreover, this scenario is in concert with the philosophies of Concurrent Engineering and system life-cycle engineering. Lack of integration between most currently available tools forces the system designer to manually perform the required data exports and imports. A single consistent database further ensures effective utilization of these tools to perform predictions and estimations. The overall objective of this research is to interact with selected commercial software vendors and progress towards an increased integration between computer-based logistics models and tools.

Computer-based tools have traditionally been used to facilitate the prediction and estimation of various relevant system parameters. For example, reliability, maintainability, and life-cycle cost. Unfortunately, influenced by the existing computer tools environment, the corresponding analyses have remained stand-alone as well. The communication and feedback essential to such analyses are absent: this prevents the system designer from exploring these models and tools to their full potential. Figure 12 depicts this traditional and nonintegrated approach to logistics analysis.

Concurrent Engineering and system life-cycle engineering involve the timely and simultaneous, rather than sequential, consideration of numerous design, production and construction, operations, and support-related system parameters. The system requirements should address both the prime mission and the necessary sustaining support.

THE SREA ENVIRONMENT

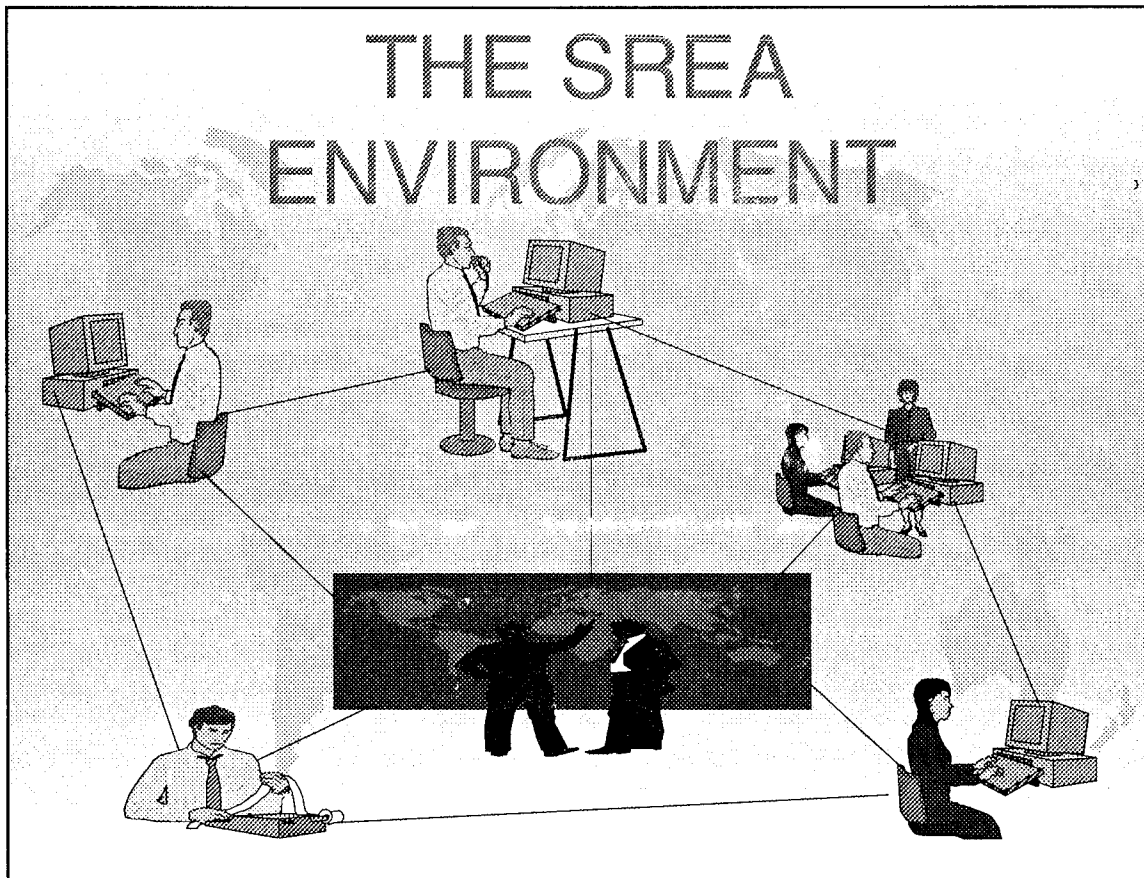

Figure 11. The Systematic Readiness Engineering Analysis Environment

“The System Engineering design laboratory is overcoming the current lack of integration between most available computer-based logistics tools through a process of linking their inputs and outputs. The result is an approach in which the different analyses are conducted in a concurrent manner during the system design phase. The resulting process is truly iterative, with appropriate feedback loops originating at each individual analysis.” (27:35)

The iterative nature of the analyses ensures the required concurrency to achieve the objectives of an integrated Logistics

Support Analysis strategy. The data that may need to be communicated across and between various analyses is made explicit in Figure 13 (next page).

Efforts expended in performing these interchanges of information among analyses are justified given the significance of the benefits obtained. It is important to mention that numerous commercial tools are available for each analysis that may need to be performed during the system design process (for example, Failure Mode Effects Criticality Analysis (FMECA), reliability allocation and prediction, and maintainability allocation and prediction). The approach outlined in this paper is independent of the tools selected.

The development of a truly integrated logistics analysis environment will significantly contribute to the increased robustness of the system or product ultimately deployed in the field. Such a workstation will facilitate the necessary consideration of various “downstream” logistics issues during the early design phases. The logistics analysis tools need to be compatible with a standard database structure. Information used and generated by these analyses could then be stored in a standard format. This would enable data exchange both within a project and among cooperating organizations, in accordance with the current trends relative to the Continuous Acquisition and Life-Cycle Support initiative.

Summary

As we have discussed, there have been extensive changes in the world of acquisition. The impacts of reduced manpower (both military and civilian), the limitations of new weapon system

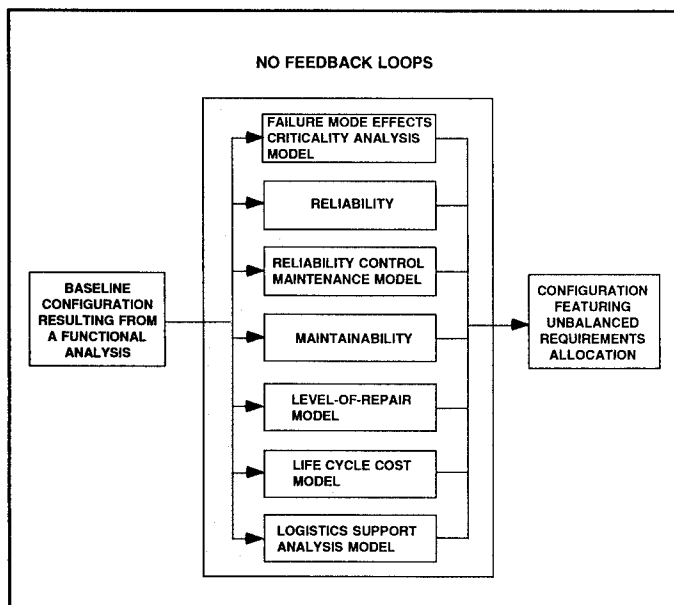

Figure 12. Traditional, Nonintegrated Approach to Logistics Analysis

acquisitions, the reorganization and closures of defense activities, the changing industrial base, the curtailment in the use of MIL-STDs and MIL-SPECS, and the ever decreasing defense dollar have created opportunities for logisticians to provide supportability without loss of quality or system degradation. In providing the proper levels of support for the end user, today's logistician is forced to glean the most beneficial information from the least number of sources available in order to conduct business within the time and money constraints allowed. We no longer have the luxury to incorporate separate analytical tools which render the same information. One approach that would accommodate this restriction is Systematic Readiness Engineering Analysis.

SREA will combine the principles of SE, CALS, CE, TQ, LSA, and ILS into an integrated systematized process. It would generate the technical data used to develop logistics products, eliminate the need for separate logistics element analyses, and be flexible enough to accommodate any type of acquisition.

SREA will require the initiation of multidisciplined acquisition teams that would consist of: the end user; design; reliability, maintainability, and availability; human factors; logistics engineers; and personnel from the various ILS disciplines. These multidisciplined teams would conduct studies or analyses aimed at influencing the design of a system based on parameters from the various disciplines. In this type of environment, the supportability parameters of an item would influence the design as the theory of LSA states, but in practice did not do so because it was initiated too late to actually influence the design with supportability parameters. SREA would define the processes and the procedures that need to be accomplished both in the early stages of concept development and system development and then

in the post development stages of an acquisition to properly define, determine, implement, and perpetuate the support system for the life of the acquisition.

SREA will cause the flow of information to be initiated from a single source, beginning in the preconcept phase. This information would then be used to evaluate the sensitivity of changing various parameters of the system to determine criteria for the life-cycle maintenance of the system (sparing models, changing mission scenarios, or cost considerations). This information would reside in a SREA workstation environment. The SREA environment will document all engineering and logistics data for the system for the entire life cycle of the system. This will simplify and integrate all of the various SE and ILS processes into one process and would fill the voids created by the inadequacy of the approaches employed today. The goal of SREA would be to provide total support to the logistician and engineering staff with minimal cost, minimal information degradation, and minimal downtime.

The SREA environment will allow the users of this concept to conduct analysis in an integrated fashion on a computer workstation. The use of technology will enhance the effectiveness and efficiency of the analyses being conducted.

Conclusion

The next step in the development of the SREA concept is the complete development of the SREA workstation and performing a case study implementing the SREA concept.

Understand, that in the SREA concept, there is no need for Military Standards. This process lends itself to become a commercial practice that has governmental application as well. The flexibility of SREA is one of the major features that will

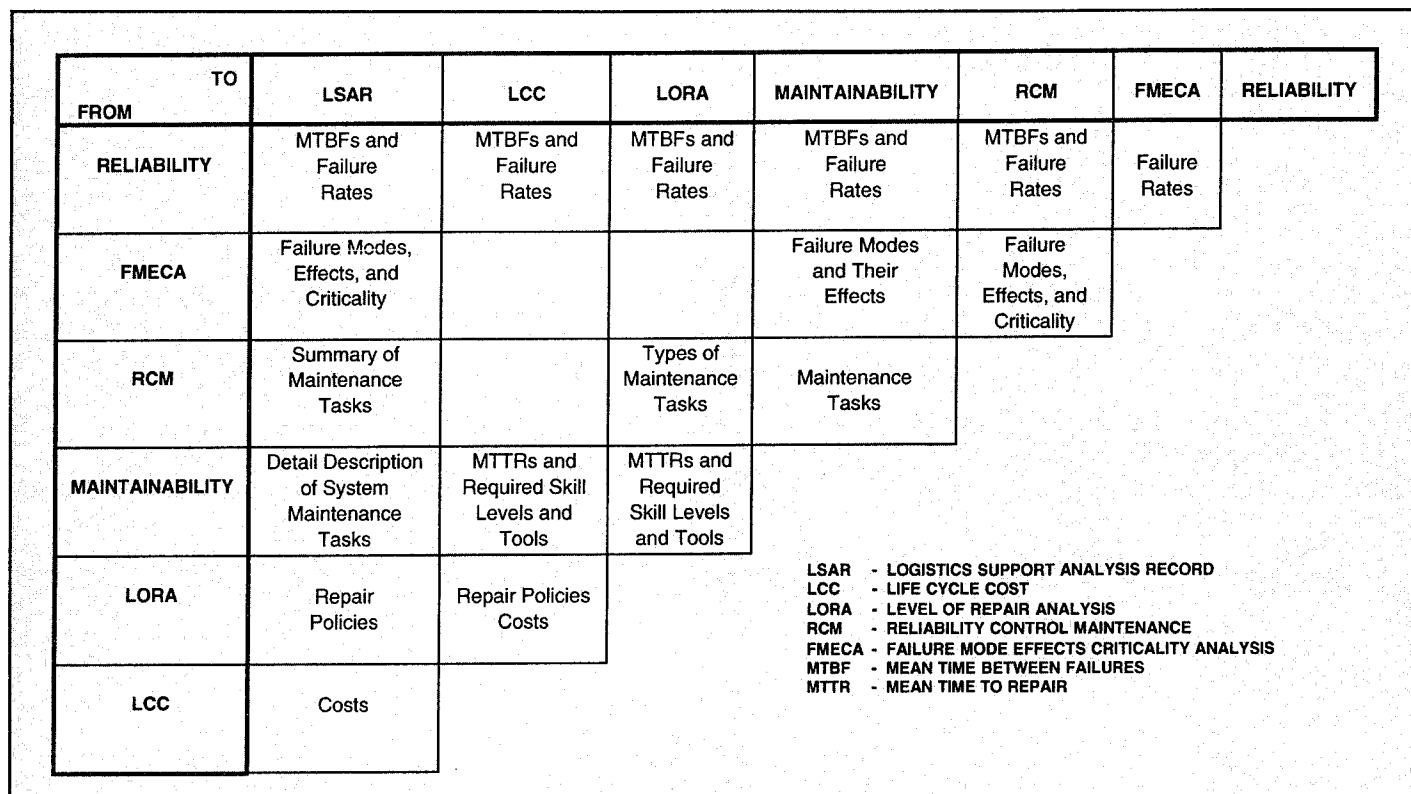

Figure 13. Proposed Communication Flow (26:36)



CURRENT RESEARCH

Air Force Materiel Command (AFMC) Studies and Analyses Program

The AFMC Studies and Analyses Office (AFMC SAO), formerly the Management Sciences Division (HQ AFMC/XPS), is responsible for developing, managing, and executing Headquarters Air Force Materiel Command's studies and analyses program of significant materiel issues. We have focused our efforts on the development and enhancement of mathematical models which can relate materiel resource decisions to resultant impacts on weapon system availability so AFMC can prioritize and justify its investments in resources. We work closely with our customers as we design and perform studies to ensure we have a healthy balance between the rigorous application of operations research techniques and practical solutions that can be implemented.

The SAO senior staff consists of:

Mr Victor J. Presutti, Jr., Chief, DSN 787-3201

Mr Curtis E. Neumann, Analytic Applications Function, DSN 787-6920

Mr Paul Frank, Concept Development Function, DSN 787-7408

The following is a partial list of current/recent SAO efforts:

Support to Lean Logistics and Reengineering Initiatives. Lean Logistics is an Air Force initiative to speed up the procurement, repair, and distribution of spare parts to provide better service to the end user at the lowest possible cost. We continued our support of Lean Logistics as well as the work of some of the AFMC reengineering teams when their efforts began merging with Lean Logistics efforts last year. A major issue was deciding how to better establish base and depot stock levels. As described below, we were a main player in the analysis of alternative methods of setting levels and are now a key developer in the implementation of Readiness Based Leveling (RBL). When the Stock Control and Distribution Reengineering team selected the Distribution and Repair in Variable Environments (DRIVE) Distribution Module (DDM) as the preferred way to distribute Air Force spare parts, they asked for our help to resolve several design and implementation issues. For determining which items to put into repair, several approaches were being considered for use by the initial Lean Logistics test shops. We helped develop the basic architecture for a system that would satisfy the required functions. This system is known as the Exchangeable Priority Repair Support System (EXPRESS). We were also asked by the Requirements Reengineering team to help analyze the feasibility and usefulness of their proposed concept of a Working Fund Account (WFA) which would drastically change the way the Air Logistics Centers (ALCs) get Obligation Authority for both buy and repair. Most of our work on these related efforts has been incorporated into Pacer LEAN which will test the new management initiatives presented by the AFMC Commander in his Senior Leader Materiel Course (SLMC). A specific effort in

support of SLMC was our development of a new Quality Performance Indicator that measures base maintenance wait time to reflect how effectively AFMC is providing parts support to our operational customers. (Analysts: Bob McCormick, Barbara Wieland, Curtis Neumann, Victor Presutti, DSN 787-6920)

Retail and Wholesale Stockage Levels for the Air Force. We accomplished two key related efforts for setting stock levels in support of Lean Logistics initiatives. We first analyzed alternative methods for determining base and depot stockage levels. We found that the Readiness Based Leveling (RBL) method for setting both base levels and the depot working level performed best in terms of minimizing expected worldwide backorders at the operating bases. (The depot working level is terminology used in Lean Logistics and is defined as the depot repair pipeline quantity plus depot serviceable stock or depot safety level.) Based on our work and a complementary effort by the Air Force Logistics Management Agency (AFLMA), the Air Force Stockage Effectiveness Board (AFSEB) decided to implement RBL for computing both base stockage levels and depot working levels. Implementation is scheduled for October 1996. In the interim, we were asked by the Lean Logistics office to compute base and depot stockage levels for items repaired by several shops selected to demonstrate Lean Logistics concepts beginning in early 1996. We were nearing completion of this effort for the initial shops at year's end. Since non-Air Force demands are not included in the basic RBL approach, we also completed the development of an approach for including non-Air Force demands in the depot working level. (Analyst: Bob McCormick, DSN 787-6920)

Weapon System Program Assessment Review (WSPAR) Modeling Assistance and Technical Support. A WSPAR is a high-level briefing on the health of a weapon system and shows expected capability relative to the planned operational requirement. Problems with weapon system support are discussed, along with proposed solutions, and forecasts of future peacetime and wartime capability. The Sustainment Executive Management Report (SEMR) provides several indicators of weapon system health and is used at a WSPAR to present data in a standard format. In preparation for the last C-5 WSPAR, the System Program Director (SPD) asked us to evaluate the SEMR indicators and make recommendations. We worked with a team that made significant improvements to the SEMR indicators. We also conducted an in-depth sensitivity analysis to demonstrate how various funding and pipeline factors affect future weapon system availability. (Analysts: Mike Niklas, Tom Stafford, DSN 787-6920)

T-1A Jayhawk Spare Engine Requirements Review. The Air Force Audit Agency asked us to evaluate several different computation options for the T-1A engine. We developed a report that relates the engine requirement to aircraft availability. This

work showed a much lower spares authorization level (28) was needed than had originally been recommended (40). The report demonstrates that several million dollars worth of spare engines can be saved while maintaining high aircraft availability. (Analyst: Mike Niklas, DSN 787-6920)

Reducing Authorizations of Low-Demand Items. The Air Staff asked us to help with an initiative to reduce the number of items in Readiness Spares Packages (RSPs). We analyzed the range, depth, cost, weight, cube, and demand history of RSP items to identify those which could possibly be regionalized. We provided our results to the Air Staff to use to examine the possibility of regionalizing assets to just a few locations worldwide. This could result in significant reductions in deployment quantities while still making parts available if actually needed. (Analysts: Mike Niklas, Bill Morgan, DSN 787-6920)

Initial Sparing. The Air Force applies readiness based sparing (RBS) when calculating recoverable item spares requirements for peace and war, but in the past, RBS has not been applied to new systems or Foreign Military Sales (FMS). In support of several distinct sponsors, we developed a spares management system consisting of a Foxpro database linked to the RBS model the Air Force uses to compute war spares. This system has been delivered to the F-22 System Program Office, an FMS office in San Antonio for use with the International Weapon Item Projection System (IWIPS), and the requirements reengineering team that is revising the Air Force provisioning process. It will soon be provided to Argentina to calculate a cost-effective spares mix to help them improve C-130 support. (Analysts: Karen Klinger, Mike Niklas, DSN 787-6920)

Joint Logistics Systems Center (JLSC) Support. Our office is a member of the JLSC "math models group" tasked in a joint Department of Defense (DOD) effort to devise common requirements models to be used by all the DOD components. We are being funded by the JLSC to look specifically into the area of multiechelon, readiness based sparing (RBS) techniques and are working to determine which of the RBS models available in DOD best computes Air Force Initial Requirements Determination (IRD). We are part of a component team working with the JLSC and their contractors in the development of an IRD/RBS workstation. This workstation contains the candidate suite of RBS models made available from the Services from which we are working to determine which method best provides the desired functionality for a readiness based IRD system. Other areas where we are focusing our efforts include testing a "standardized" wholesale Economic Order Quantity (EOQ) model. This testing will include the analysis of the proper parameter settings (ordering cost and maximum acceptable probability of stockout) required by the Air Force for a consumable item requirements computation. (Analyst: Bill Morgan, DSN 787-6920)

Reparable Stock Division (RSD) Banding for Effectiveness. We are continuing to refine the RSD Banding process for distributing Obligation Authority (OA). This year the banding process was not necessary since RSD procurement was fully

funded. However, AFMC has been given the authority to flex OA between stock fund accounts so the banding procedure was used to help determine how much RSD procurement OA could be shifted without seriously affecting support. (Analysts: Fred Rexroad, Capt Rob Block, Bill Morgan, DSN 787-6920)

Combat Logistics Support Squadron (CLSS) Aircraft Battle Damage Repair (ABDR) Teams. We were asked by HQ AFMC/LGM to help develop an approach to assign CLSS ABDR teams which support war-tasked weapon systems. We analyzed the weapon systems' planned wartime Primary Authorized Aircraft (PAA) levels, utilization rates, complexities, and vulnerabilities to determine if there were any relationships to the existing number of teams assigned to each of the weapon systems. Using regression analyses we found a very good relationship between the assigned number of teams and an interaction variable of wartime PAA and weapon system vulnerability. Our findings supported tentative plans to reassign a few of the teams. The resulting regression equation can be used as a management tool to support future decisions in manpower allocations. (Analysts: Thomas Stafford, Barbara Wieland, DSN 787-6810)

Low Altitude Navigation Targeting InfraRed for Night (LANTIRN) Supportability Assessment. The LANTIRN System Program Office (SPO) was conducting a supportability assessment and asked for our help in retrieving and analyzing data for items on their system. They asked us to first focus on LANTIRN support equipment (SE) items. We gathered data from the D041 Requirements Computation System on requirements, asset status, pipeline segments, and other basic information for these items. Comparing requirements to on-hand assets, we found that only 8 of 577 SE items needed buy actions. We also compared the ratio of serviceable to unserviceable assets for nonproblem and problem parts. The problem parts had a much lower ratio of serviceable to unserviceable assets suggesting that a repair problem may be the cause. This data was well received by the SPO, and they have asked us to continue this project concentrating now on LANTIRN Navigation and Targeting pods. (Analysts: Jean Graham, Bill Morgan, DSN 787-6810)

Command, Control, Communication, Computer, and Intelligence (C4I) Equipment Assessment Tool. We were asked by HQ AFMC/DR to develop a prototype peacetime assessment capability for non-aircraft C4I systems. The Ground Theater Air Control System (GTACS) was chosen as a test system. Our approach is to modify the Aircraft Availability Model so that it can be used to assess equipment-type applications. A major hurdle was a lack of data showing the indenture structure of the recoverable items on nonaircraft applications. We overcame this by developing software to build levels of indenture files for the GTACS equipment from the Application, Program, and Indenture (API) files. We expect to deliver the prototype to DR in May 1996. The assessment tool will provide the capability to generate a requirement, modify goals, evaluate asset positions, and make some estimates of system availability due to supply. (Analysts: Fred Rexroad, Jean Graham, Steve Bankey, DSN 787-7408)

(Continued on middle of page 38)

Containerization Adds Flexibility for Military Deployments

Danita L. Hunter

Turbo Intermodal Surge 1995 Exercise

Fort Carson, Colorado, and the Port of Oakland, California, were the sites of the United States Transportation Command's (USTRANSCOM's) recent Turbo Intermodal Surge 1995 (TIS '95) exercise. Industry and the military worked together to containerize a mechanized artillery battalion's equipment including 49 tracked vehicles, 133 wheeled vehicles, and other mission essential equipment. After the equipment was containerized, it was loaded on trains and taken to the Port of Oakland where it was unloaded and loaded onto a commercial containership. Then it was unloaded and put back on the train for return to Fort Carson.

USTRANSCOM's goal is to promote an effective and efficient intermodal container transportation system by increasing Department of Defense's use of intermodal systems, ensuring interoperability between the Department of Defense (DOD) and commercial systems, and maximizing use of intermodal assets and infrastructure. Exercises such as Turbo Intermodal Surge (TIS) and Turbo Containerized Ammunition Distribution System (CADS) demonstrate the effectiveness of containerization, intermodalism, and in-transit visibility.

In most of the military's deployments, people deploy by air and cargo deploys by a combination of sea, air, and land, depending on the size and amount of equipment as well as when the equipment is needed. Most military cargo has historically

been shipped overseas using breakbulk ships and roll-on, roll-off (RORO) ships. However, the industry standard in commercial shipping for the last 20 years has been the use of containerships and their associated intermodal support systems on land. To take advantage of commercial resources, the military must also move to containerization.

The currently preferred method of military cargo deployment is RORO ships. However, the number available is limited, and the turn around time could be a month or more from the time a RORO leaves the United States, arrives at its destination, and returns. Deploying units may not be able to wait for a RORO to deploy. Time may be, and usually is, a critical element in a contingency.

Being able to move combat forces using containers from where they are stationed in the United States to where they are needed in a contingency is critical. That is the purpose of exercises such as Turbo Intermodal Surge: to ensure the military can work with commercial systems to move when and where needed.

Taking full advantage of containerization will allow USTRANSCOM to move units and equipment earlier in the deployment flow without competing for the more scarce RORO ships. Additionally, it improves our capability to respond to more than one crisis at a time. Containerization also means less supervision is required at the port when the equipment is handed off from the military to commercial shippers. Less handling of



A High Mobility Multipurpose Wheeled Vehicle (HMMWV) Is Driven Into a 40-Foot Container at Fort Carson, Colorado, as Part of the Loading Portion of United States Transportation Command's Turbo Intermodal Surge 1995 Exercise. Two HMMWVs or a Combination of Vehicles and Trailers Were Loaded Into Each 40-Foot Container.

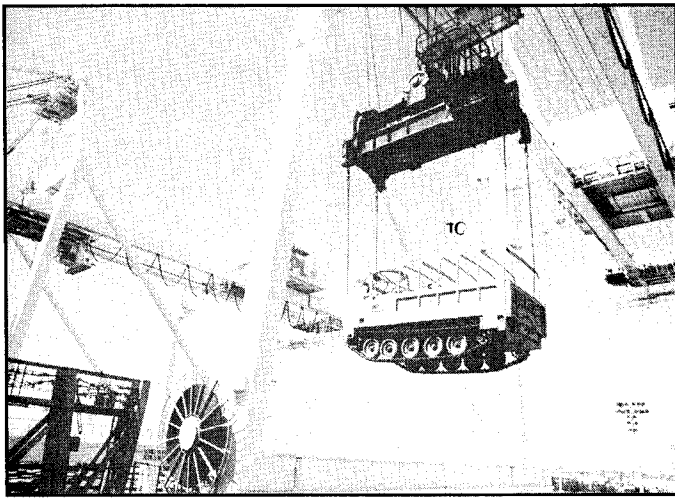

A Cargo Carrier Is Lowered Into the Hold of American President Lines' *President Adams* at the Port of Oakland During the Turbo Intermodal Surge 1995 Exercise.

equipment equates to less damage during shipment to the theater of operations.

The stuffing of 26 40-foot containers and 33 flatcars for oversized equipment at Fort Carson went better than anyone expected. According to the war games used to plan the timeline taking multiple variables into account, it should have taken between 1.5 days in the best scenario and 5 days in the worst case. It took about 10 hours from the time the first vehicle rolled out of the motor pool until the last flatrack was loaded onto doublestack and articulated railcars. Articulated railcars are more than 300 feet long and equipped with special chassis and suspension systems that allow them to negotiate turns and give the equipment a smooth ride. Doublestacks simply allow one container to be stacked on top of another one.

Part of the reason for the rapid loading was that three ramps were going at one time loading vehicles into containers. Cranes lifted other vehicles onto heavy-duty military flatracks. Once the vehicles were tied down for transport, a top loader picked up the loaded flatracks and placed it on the train. After the loading was rapidly progressing, a second top loader was added.

In addition to the 40-foot containers and flatracks, there were also 41 Quadruple-Containers (QuadCon) used in this exercise. The QuadCon is a new piece of equipment for the US Army. In fact, the 3rd Battalion, 29th Field Artillery (3/29th FA), 4th Infantry Division, at Fort Carson, is the only Army unit to use them. A QuadCon is a set of four small containers connected together to create the equivalent of one 20-foot container. Inside the small containers were repair parts, maintenance equipment, petroleum, oils, lubricants, tents, and other items.

Soldiers weren't the only ones who had a great deal to learn about this type of operation. The crane operators, an invaluable asset in this type of operation, had to learn how to lift vehicles for the exercise. Overcoming the learning curve, including training the civilian crane operators to lift vehicles, took about two hours on the morning the loading began. Since the crane operators were subcontracted by the contractor, it was not known who they were until they showed up on the day of the loading.

Once all of the loading was done, the Santa Fe and Southern Pacific railroads' trains—one full of oversized equipment and the other loaded with containers, flatracks, and QuadCons—departed Fort Carson for the Port of Oakland. Once in Oakland, the US

Army's 1302nd Major Port Command, American President Lines (APL), and Sea-Land unloaded the equipment from the train and took it to the terminal. Then they loaded it onto APL's *President Adams* ship at the Port of Oakland.

Because of the size of the equipment, months before the exercise took place, APL and Sea-Land representatives visited Fort Carson to assess the size and weight of each piece of equipment to be moved. Once completed, they formulated their plans on how to load the equipment onto the ship. Although the initial plans changed, the time spent during the actual loading of the artillery equipment averaged about nine minutes per vehicle, which was better than the 15 to 20 minutes initially expected.

After the ship was loaded, the equipment was unloaded. The *President Adams* never left its berth at the Port of Oakland with the equipment on-board. Then the equipment was reloaded onto the trains for the return trip to Colorado.

What made TIS '95 become a reality was the cooperation of agencies—like USTRANSCOM, the US Army's Military Traffic Management Command (MTMC), and the US Navy's Military Sealift Command (MSC) (two of USTRANSCOM's component commands), APL, Sea-Land, Santa Fe Railroad, and Southern Pacific Railroad—all pushing toward the goal of a containerized deployment using an artillery battalion. MTMC's transportation engineering agency provided the engineering expertise to containerize the equipment, and MTMC western area and their subordinate command (1302nd Major Port Command) provided operational expertise.



A QuadCon Is Being Carried by a Palletized Load System Vehicle During Turbo Intermodal Surge 1995 Exercise.

USTRANSCOM chose the 3/29th FA to participate in this exercise because they are not generally one of the first combat units to deploy. RORO ships may not be available for this division to deploy with. USTRANSCOM intentionally picked a unit that may have to move using container ships.

The overall exercise was deemed a tremendous success by USTRANSCOM officials. Not only were the goals met and completed on time, but it was also completed within budget. The cost of the exercise was only \$1.6 million, which was significantly less than the original cost estimate, including an \$823,000 commercial contract. The success of containerized operations exercises, such as Turbo Intermodal Surge, benefits not only USTRANSCOM and the military but commercial carriers as well.

Ms Hunter is presently Chief, Command Information, United States Transportation Command, Scott AFB, Illinois.



Application Standard for Shipping Container Codes for UCC/EAN Identification Codes

The Uniform Code Council, Inc. published a new standard in December of 1995. The *Application Standard for Shipping Container Codes* manual specifies the use of Uniform Code Council/European Article Number (UCC/EAN) identification codes on shipping containers, emphasizing the use of bar codes for the identification of cases, cartons, modules, pallets, and other containers.

This manual combines and replaces two previous documents: (1) the *U.P.C. Shipping Container Code and Symbol Specification Manual* and (2) the *Application Standard for the UCC/EAN-128 Serial Shipping Container Code*. The new manual provides a single source for shipping container identification code standards.

The identification codes are numbers used to access information about products and shipments and are specified as one of two formats. The SCC-14, formerly known as the U.P.C. Shipping Container Code, is the fourteen digit number used to identify fixed or standard products, such as standard pack cases. The SSCC-18, formerly known as the Serial Shipping Container Code, is the eighteen digit number used to "license plate" unique or variable-pack products and shipments.

Three bar code symbologies are indicated for use with these identification codes: (1) the Universal Product Code (U.P.C.), (2) Interleaved 2-of-5, and (3) UCC/EAN-128. Rules for use within the UCC/EAN international system are detailed, including

size and dimensions, number and location of labels on the container, and symbol quality requirements. Modular label formats for transport packages are explained, and support standardized label generation and interpretation templates.

Significant changes from the previous standards include the limitation of Interleaved 2-of-5 to the encoding of primary identification only. UCC/EAN-128 is also used for primary identification, and is the preferred choice for add-on bar codes. The manual also recommends the acceptance of the whole international set of fixed data identification codes; U.P.C., EAN-13, and the SCC-14, and points out that full functionality means that systems need to handle field sizes of fourteen digits for primary product identification. Additionally, symbol location specifications have been combined into a single standard that is indifferent to print processes or bar code symbology. These specifications include standards for cases, modules, pallets, truckloads, and other handling units.

The *Application Standard for Shipping Container Codes* has been proposed as an American National Standard, and is available from the Uniform Code Council, Inc. For more information call the Uniform Code Council, Inc. at (513) 435-3870.

Teresa Mitchell Ennan
Uniform Code Council, Inc.
8163 Old Yankee Road
Dayton, OH 45458

(Continued from page 35)

Social Actions Database System. The AFMC social actions office is responsible for reporting military equal opportunity/human relations incidents to the AFMC commander monthly and to Headquarters Air Force Personnel Center (AFPC) semi-annually. In the past, all data collection and report development was done manually and took several weeks to accomplish (approximately 420 man-days for AFMC alone in the completion of the two semi-annual reports). An automated reporting system was sought to improve the timeliness and accuracy of social

actions reporting. In 1995, we developed and delivered a prototype database system which the AFMC social actions office is currently testing and evaluating. Expected impact is a savings of approximately 360 man-days for AFMC reporting. AFPC is very interested in our prototype and plans to use it as the basis for a system they will develop by October 1996 for the entire Air Force social actions community. (Analyst: Karen Klinger, DSN 787-6920) 

Most Significant Article Award

The Editorial Advisory Board has selected "A New Look at Wholesale Logistics" by Wing Commander David J. Foster, RAF, as the most significant article in the Fall 1995 issue of the *Air Force Journal of Logistics*.

INSIDE LOGISTICS

EXPLORING THE HEART OF LOGISTICS

Air Force Acquisition Model (AFAM)

Linda R. Titcombe

The AFAM/Deskbook Joint Program Office was established in November 1991, at the direction of General Ronald Yates, Air Force Materiel Command (AFMC) Commander (1991-1995). AFAM is located at Wright-Patterson Air Force Base, Ohio, and is assigned to the Aeronautical System Center's Program Management Directorate of AFMC. General Yates wanted an automated tool to define the acquisition process and a method to share best practices and lessons learned. AFAM is an automated encyclopedia depicting and outlining all six phases of the acquisition process from cradle to grave. The model is designed to assist research and development (R&D), acquisition, and support personnel in performing tasks for major weapon system programs and non-major acquisitions. Originally targeted toward the inexperienced, AFAM has expanded its audience to include all personnel. The AFAM/Deskbook Joint Program Office was set up to develop the system and manage the data.

The model started incrementally with the release of version 1.0 to 40 select Program Offices/Product Directorates in July of 1992. By September, the model was released command wide. Each subsequent version adds more enhancements and data; each release adds to the growing customer base. Subsequent releases occur twice a year, reflecting the current business practices and corporate knowledge changes. Version 3.0 was released in January 1996 to over 2,000 using organizations within the Air Force, other Services, and the Department of Defense (DOD). Future enhancements being developed include on-line Internet capability and multiplatform application.

Program office personnel designed AFAM, using the best ideas and guidance available from DOD talent and experience. The user is the most important source of information for the model along with functional points of contact located at the air logistics centers, product centers, and test centers. Headquarters AFMC functional representatives located within the AFAM/Deskbook Joint Program Office are responsible for data collection and the validation process. Additionally, senior leadership continues to provide guidance, direction, and support. Feedback and surveys of customers are the driving force for the past and future enhancements. One customer-driven enhancement is the graphical display of the network of tasks in a flowchart, illustrating the relationships between the tasks.

In the past, the model had two distinct parts, the Task Breakdown Structure with its associated descriptions, references,

lessons learned, etc. and the AFAM Supplement which was the document text and retrieval portion. These have now been merged into one seamless piece of software. Version 3.0 includes technical enhancements such as global search of all text files, multiple documents interface (MDI), and a total MSWindows look and feel. The Reference Library includes documents that launch MSWord files and PowerPoint files. AFAM is easy to use and contains high quality and current information. Anyone who can point and click a mouse quickly gets valuable acquisition information to assist in completing a task.

With the release of Version 3.0 in January 1996, AFAM identifies and organizes over 6,000 tasks and subtasks covering all functional disciplines into a Task Breakdown Structure (TBS). The Reference Library includes 223 acquisition-related documents such as directives, Acquisition Reform information, air staff or major command policy letters, regulations and instructions, MIL-standards, pamphlets, guides, and handbooks. The various "acquisition documents" contained in the Reference Library have been identified as having a strong relevance to the acquisition process. Although the Reference Library may not have all of the "essential" documents needed for a particular action or process, it does provide a repository of many of the documents in one location, all at one's fingertips. Due to the broad range of information, the model is of interest throughout the DOD community.

AFAM's software describes each task associated with the acquisition process in lay terms. AFAM aligns the tasks in a predecessor (before) and successor (after) network. Details for each task include information, such as required inputs and outputs, approximate timelines, and resources essential to complete the task. Office symbols of task experts and their phone numbers are found at the bottom of the description. The Help pull-down menu includes features such as the Users' Manual, an Acronym List, a Feedback Form for the users' convenience, and an About AFAM feature that lists phone numbers and mailing addresses for the AFAM/Deskbook Joint Program Offices.

AFAM provides specific information for each task. This information is found on the Task Relationship Window. If the information is not available, it will not appear in the window (in the previous versions, buttons with no information were grayed out). The following is a description of the type of information the Task Relationship Window may contain:

- Task Descriptions - Text window with a few paragraphs describing the task in lay terms. At the bottom of the file is a listing of office symbols and phone numbers of

- organizational "experts."
- References - Brief synopses of each directive, regulation, and policy letter that applies to that task. When possible, each referenced item provides the appropriate paragraph number. The documents found in the Reference Library have a direct link to the supplement. The system will take the user directly to the exact paragraph in the document referenced. Access to the Reference Library is available from the toolbar on any window within AFAM.
- Time Lines - This category provides the nominal time it takes to complete the task. This information can assist the program manager in establishing schedules.
- Local Information - Place to store information pertinent to user's site or organization, or information to be submitted for the next release of AFAM. The information is maintained by the using organization or site.
- Predecessor - Tasks that may need to be completed before you begin the current task. This gives you a roadmap of what came before the current task.
- Successors - Tasks that may need to be completed after you have finished the current task. This gives you a roadmap of where to go after the task is complete.
- Best Practices - These are a compilation of actions that have been followed with good results; **actions to take**.
- Lessons Learned - These are a compilation of actions that have been followed with not very good results; **actions to avoid**.
- Expert Wisdom - The heart of AFAM that captures the experience of AFMC's most seasoned experts. Recommendations, the best way to do business, and the "make-sure-you-don't-do-this" items are here for others to use.
- Templates and Samples - This area provides example documents and formats.
- Courses - This provides a synopsis of formal training courses. This includes information about the course and where to call to get the schedules and how to apply for the class.

AFAM is distributed on File Transfer Protocol (FTP) or CD-ROM. The AFAM runs from a Local Area Network (LAN), a CD drive, or a stand-alone computer hard drive.

- Hardware Minimum Requirements: IBM compatible 386 computer; 8 MB of total RAM; 100 MB hard disk; Mouse

(highly recommended); VGA Monitor.

- Software Minimum Requirements: Microsoft Windows 3.1, Microsoft Disk Operating System (MS-DOS) version 4.01 or higher.

Complete support for the installation and use of the model has been established. A help desk is available on a 24-hour basis (via an answering machine) by calling DSN 785-0423 or commercial (513) 255-0423. A response will be given to any call by the next duty day.

The AFAM/Deskbook Joint Program Office actively focuses on the customer. Site visits, briefings, and demonstrations are routinely accomplished by AFAM teams. Support for training, identifying functional operations, and new enhancements available within the current release is provided upon demand. A training manual is available and provides self-pace training.

The model can be found at locations such as The Defense Systems Management College (DSMC), Defense Acquisition University (DAU), Air Force Institute of Technology (AFIT), Naval Post Graduate School, Air Mobility Warfare Center, and other DOD schools. The use of the model and instruction on AFAM is being incorporated into their courses.

The AFAM program has received visibility at the DOD level from people such as the Under Secretary of Defense (Acquisition and Technology), Honorable Paul Kaminiski; and Principal Deputy Under Secretary of Defense (Acquisition and Technology), Honorable Noel Longuemare. As a result of this visibility, the AFAM office is currently developing a DOD system in the Acquisition Reform arena.

Summary

In an era of downsizing and reduced budgets, we must make better use of our resources. We are losing our experienced people and their wisdom and are coping with constantly changing guidelines. AFAM provides a living database controlled by experts. The acquisition model will have an impact on the way we do business by helping produce quality products the first time and by allowing us to share experience throughout the DOD.

To receive a copy of AFAM, contact the AFAM/Deskbook Joint Program Office at DSN 785-0416 or commercial (513) 255-0416.

Ms Titcombe is presently a project manager in the AFAM/Deskbook Joint Program Office, Wright-Patterson AFB, Ohio.

Air Force Historical Foundation Sponsors New Award

The Air Force Historical Foundation president, General Bryce Poe II, USAF (Ret), has kindly offered to sponsor a new award for authors contributing articles to the *Air Force Journal of Logistics*. The "Logistics Lessons Learned Award" will be awarded annually for the best article that contains logistics lessons learned. The first award (to be announced in the Winter 1997 issue of the *AFJL*) will be selected from articles appearing in the Journal beginning with the Winter 1996 issue.

The award will consist of a one-year Air Force Historical Foundation membership and a memento as well as recognition in both the *Air Force Journal of Logistics* and the *Air Power History* journal.

Air Force Historical Foundation Background

The Air Force Historical Foundation was established by the first Air Force Chief of Staff, General Carl Spaatz, and other founders of the independent Air Force who felt the need for a quasi-official organization to support air power forcefully and publicly. The charge given members was "to preserve and perpetuate the history and traditions of the U.S. Air Force, its predecessor organizations . . . and to provide 'lessons learned' to the active force."

The organization's first meeting, held on 27 May 1953, was attended by a host of aviation pioneers, including names like Spaatz, Eaker, Vandenberg, Twining, DeSeversky, Foulois, McKee, White, Von Braun, and over 30 others.

The Foundation, a nonprofit organization, meets its mission of preserving the heritage of the United States Air Force in a number of ways. It publishes an award winning quarterly journal, *Air Power History*, (copies are circulated by the USAF), and has produced a number of books, including *A Few Great Captains*, *Forged in Fire*, *Hap*, *Air Force Spoken Here*, *Iron Eagle*, and *Makers of the United States Air Force*.

It also conducts major symposiums on various Air Force themes. These have included "Tactical Air Power" (1990); "Development and Support for Combat Air" (1991); "Strategic Air Operations" (1992); "The USAF in Space" (1995); and two with their counterparts of the Royal Air Force Historical Society - "The USAF/RAF Cooperation in World War II" (1990), and "Anglo-American Cooperation During the Cold War Era" (1993). These symposiums are captured on audio/video tape that is made available to the Air University, Air Force Academy, Reserve Officer Training Corps, and other organizations. In some cases Proceedings are published as well.

In addition, the Air Force Historical Foundation has an award program to recognize outstanding articles, reports, research, etc. related to air power. The "Logistics Lessons Learned Award" for the *Air Force Journal of Logistics* is one of many awards sponsored by the Foundation. General Poe, who retired from command of the then Air Force Logistics Command, is very interested in publicizing the Air Force Historical Foundation and the *Air Power History* journal to more logisticians, both officer and enlisted.

For membership or more information about the Air Force Historical Foundation, call DSN 858-2139 or commercial (301) 736-1959.

