

**DAHLGREN DIVISION
NAVAL SURFACE WARFARE CENTER**

Dahlgren, Virginia 22448-5100



NSWCDD/MP-96/75

**EX 419 MULTIFUNCTION FUZE MONOLITHIC
MICROWAVE INTEGRATED CIRCUITS ELECTRO-
MAGNETIC VULNERABILITY TESTS BRIEF
PRESENTED AT THE 40TH ANNUAL AMERICAN
DEFENSE PREPAREDNESS ASSOCIATION FUZE
CONFERENCE**

BY HAROLD C. WENDT FRITZ E. NEWCOMER

WEAPONS SYSTEMS DEPARTMENT

JUNE 1996

DTIC QUALITY INSPECTED 4

19960705 124

Approved for public release; distribution is unlimited.

REPORT DOCUMENTATION PAGE

*Form Approved
OBM No. 0704-0188*

Public reporting burden for this collection of information is estimated to average 1 hour per response, including the time for reviewing instructions, search existing data sources, gathering and maintaining the data needed, and completing and reviewing the collection of information. Send comments regarding this burden or any other aspect of this collection of information, including suggestions for reducing this burden, to Washington Headquarters Services, Directorate for Information Operations and Reports, 1215 Jefferson Davis Highway, Suite 1204, Arlington, VA 22202-4302, and to the Office of Management and Budget, Paperwork Reduction Project (0704-0188), Washington, DC 20503.

1. AGENCY USE ONLY (Leave blank)	2. REPORT DATE June 1996	3. REPORT TYPE AND DATES COVERED Presentation, 18 April 1996	
4. TITLE AND SUBTITLE EX 419 Multifunction Fuze Monolithic Microwave Integrated Circuits Electromagnetic Vulnerability Tests Brief Presented at the 40th Annual American Defense Preparedness Association Fuze Conference		5. FUNDING NUMBERS -----	
6. AUTHOR(s) Harold C. Wendt and Fritz E. Newcomer			
7. PERFORMING ORGANIZATION NAME(S) AND ADDRESS(ES) Commander Naval Surface Warfare Center, Dahlgren Division (Code G34) 17320 Dahlgren Road Dahlgren, VA 22448-5100		8. PERFORMING ORGANIZATION REPORT NUMBER NSWCDD/MP-96/75	
9. SPONSORING/MONITORING AGENCY NAME(S) AND ADDRESS(ES) Commander Naval Surface Warfare Center, Crane Division Ammunition Program Office (Code PM-4) 300 Highway 361 Crane, IN 47522-5001		10. SPONSORING/MONITORING AGENCY REPORT NUMBER -----	
11. SUPPLEMENTARY NOTES -----			
12a. DISTRIBUTION/AVAILABILITY STATEMENT Approved for public release; distribution is unlimited.		12b. DISTRIBUTION CODE -----	
13. ABSTRACT (Maximum 200 words) This brief includes the top level status of the current Multifunction Fuze (MFF) configuration as well as the process with which we developed the electromagnetic vulnerability (EMV) tests, an overview of the Transmitter (TX) & Receiver (RX) Monolithic Microwave Integrated Circuit (MMIC) designs, the details of the EMV tests, and a wrap-up with conclusions.			
14. SUBJECT TERMS Multifunction Fuze, Top Level Status, Electromagnetic Vulnerability, Transmitter (TX) & Receiver (RX) Monolithic Microwave Integrated Circuit (MMIC)			15. NUMBER OF PAGES 20
			16. PRICE CODE
17. SECURITY CLASSIFICATION OF REPORT UNCLASSIFIED	18. SECURITY CLASSIFICATION OF THIS PAGE UNCLASSIFIED	19. SECURITY CLASSIFICATION OF ABSTRACT UNCLASSIFIED	20. LIMITATION OF ABSTRACT UL

FOREWORD

This brief was presented at the 40th annual American Defense Preparedness Association Fuze Conference on the 18th of April 1996. The brief describes Electromagnetic Vulnerability tests performed on Monolithic Microwave Integrated Circuits that are part of the EX 419 Multifunction Fuze (MFF). The brief also includes an overview of the MFF configuration.

This work was sponsored by the Ammunition Program Office, PM4, of the Naval Surface Warfare Center, Crane Division.

The authors wish to acknowledge Kimberly Jones, of IMSS-CACI, who put together the brief.

Approved by:



THOMAS N. TSCHIRN, Head
Guns and Munitions Division

CONTENTS

	<u>Page</u>
TOPICS OF DISCUSSION.....	1
BACKGROUND.....	2
AD CONFIGURATION	3
E & MD FLEX CIRCUITS.....	4
E & MD RF IMPLEMENTATION	5
E & MD CONFIGURATION	6
OVERVIEW OF CHIP SET CONFIGURATION	7
TRANSMITTER	8
RECEIVER	9
TEST PARTICULARS	10
TEST PARAMETERS.....	11
TEST SETUP.....	12
TEST RESULTS.....	13
CONCLUSIONS	14
DISTRIBUTION	(1)



Topics of Discussion

- Background
- Overview Of Chip Set Configuration
- Test Particulars
- Conclusions

This brief will include a top level status of the current Multifunction Fuze (MFF) configuration as well as the process with which we developed the Electromagnetic Vulnerability (EMV) tests, an overview of the Transmitter (TX) & Receiver (RX) Monolithic Microwave Integrated Circuit (MMIC) designs, the details of the EMV tests, and a wrap-up with conclusions.



Background

- EX 419 Status
AD \Rightarrow EMD
- Process From Which The MMIC EMV Tests Were Developed

There have been a number of changes from Advanced Development (AD) to Engineering and Manufacturing Development (E&MD). Of those there have been two significant electrical changes. One of the changes is the incorporation of rigid flex technology throughout the design. AD had 5 discrete printed circuit boards (PCBs) with two flex circuits. E&MD utilizes one flex circuit, a major improvement for producibility. The other significant change is the use of two MMIC chips vs. discrete RF electronics. The MMICs are mounted on the outside of the antenna vs. two RF boards interfaced through a slot on the bottom of the antenna. The former is a more robust design.

From our experience with other fuzes, it was apparent that characterizing MFFs' susceptibility to EM energy was essential. From those early tests it was apparent that the primary coupling mechanism for the EM energy was through the antenna. This was easily deduced because the front end components of both the transmit and receive sections of the electronics were the only parts damaged. In an effort to integrate as much of the electronics as possible, a parallel effort was started. A MMIC development was initiated for the transmitter and receiver RF front end components. The plan called for three iterations. To test in an EM environments facility, after each of these iterations, could be quite costly. Our goal was to create a bench top configuration where we could characterize the MMIC's EMV easily with minimal cost.



AD CONFIGURATION

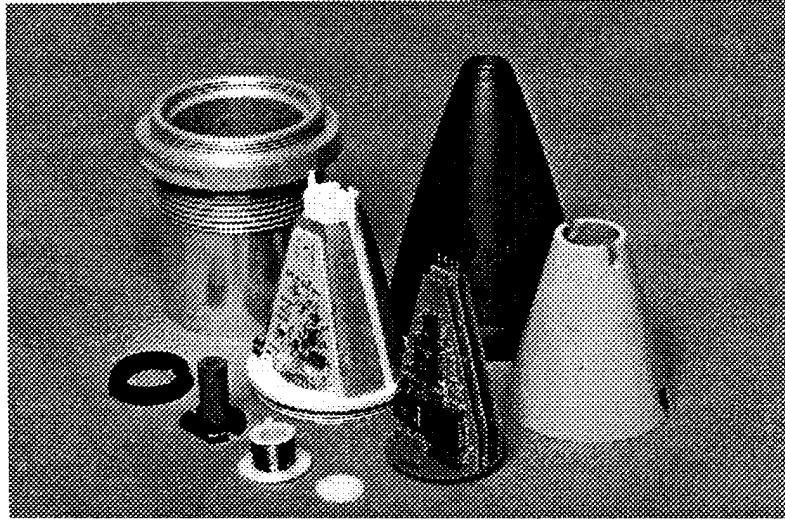

The AD fuze configuration comprised these subcomponents. As mentioned earlier, the two significant changes occurred with the RF section and electronics. The RF section was implemented with two distinct RF boards - a receiver and a transmitter. The interconnection to the antenna occurred through a slot and was then hard wired. The electronic section was made up of four separate printed circuit boards (PCBs).

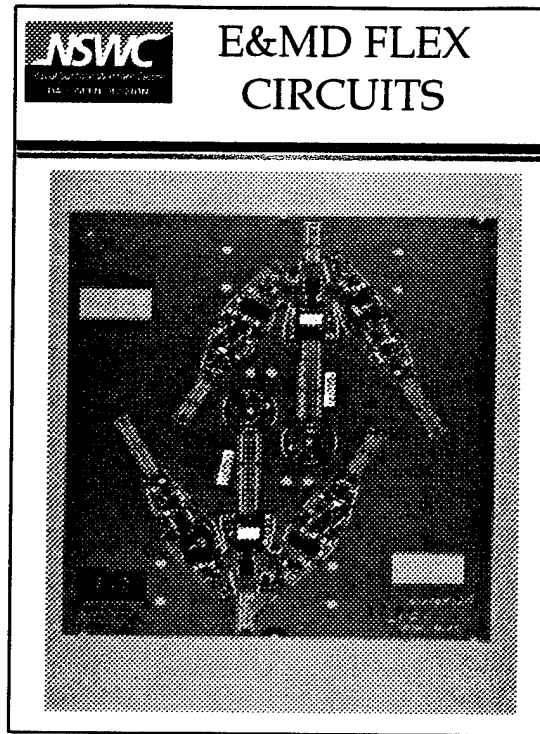

This is a picture of two rigid flex assemblies. There are two per "board" for ease of test and producibility. This assembly contains all the electronic circuits except for the two MMIC RF PCBs.



E&MD RF IMPLEMENTATION



These two pictures show the implementation of the MMIC parts. The E&MD configuration has changed dramatically from AD with the two MMIC PCBs taking the place of the two RF boards. The maglink flex can be seen at the top of this picture as well.

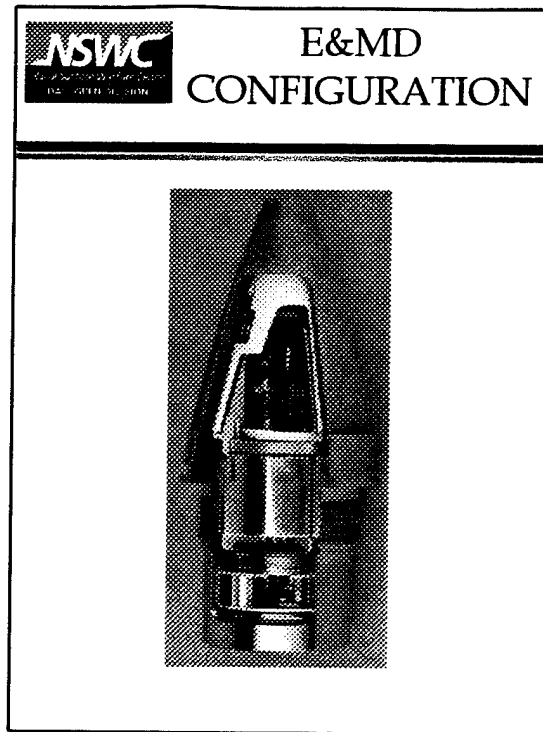

This is a cut-away of the complete E&MD fuze configuration.



Overview Of Chip Set Configuration

- Transmitter
- Receiver

Both the TX and RX were initially developed using the Heterojunction Bipolar Transistor (HBT) technology. The driver in using this technology was the need for very low phase noise in the TX. By using only one type of MMIC technology, the different circuits could be fabricated with the same process and even on the same wafer. This would save money by not requiring a different Non Recurring Engineering (NRE) cost if a second technology/process was used. Unfortunately, after the second iteration, it became apparent that the RX requirements could not be met utilizing the HBT technology. So the design was modified and implemented in Metal Semiconductor Field Effect Transistor (MESFET) technology.

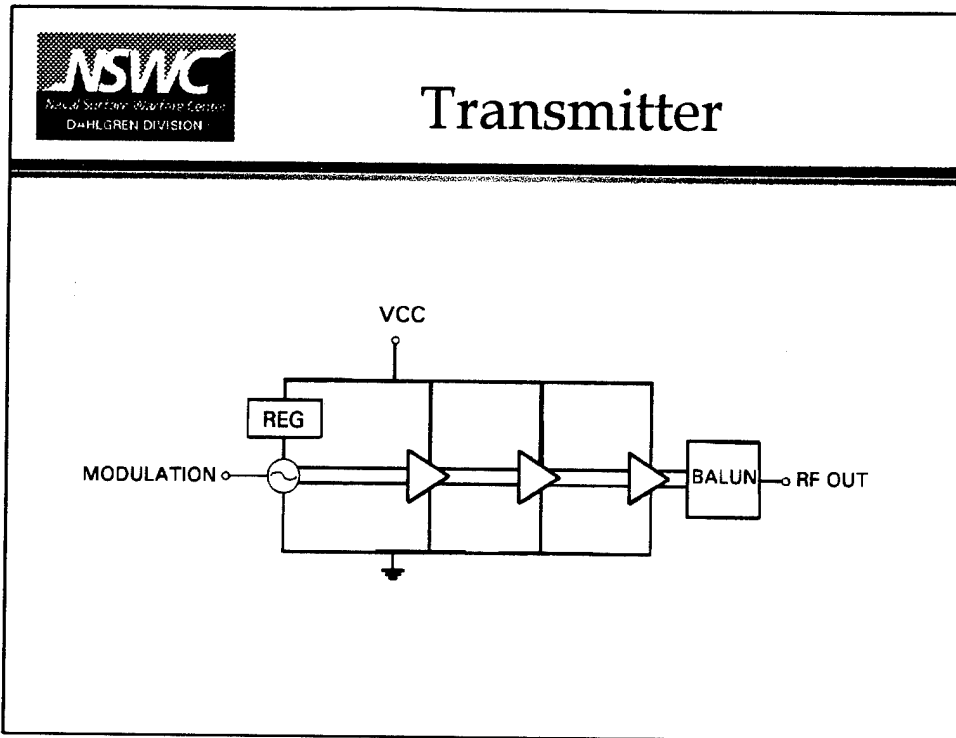

The transmitter is made up of a regulator, oscillator, a three-stage amplifier, and a balun. In utilizing the HBT technology, a balanced circuit topology could be implemented. The balanced approach has a number of advantages over the conventional single-ended approach: bias circuits utilize current mirrors for less sensitivity to process variations, transistors can be operated at twice their individual breakdown voltage levels, even order harmonics are suppressed in the amplifier stages, and less current is required because the output stage has higher impedance.

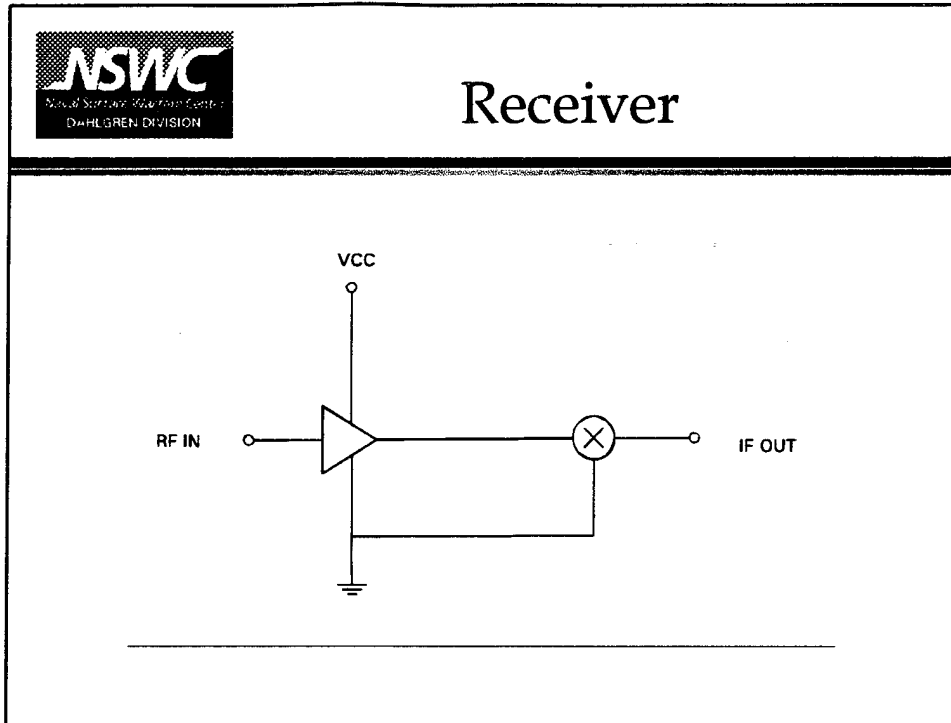

The receiver utilizes the MESFET technology. It comprises a low noise amplifier and envelope detector. The MESFET technology provides a better fit. The dynamic range required to meet the system goals was not achievable with the HBT technology.



Test Particulars

- Test Parameters
- Test Setup
- Test Results

In discussing the “test particulars,” I will go over the background information used in developing the test parameters. Then I will overview the test setup and conclude with the test results.



Test Parameters

- Fuze Operational Environments
- Two Fuze States
- Applicable Power Densities & MFF Antenna Gain

In developing the test particulars, we looked at the fuze operational environment. The most severe EM threat is the SPY-1 radar. An analysis was done to understand all the key parameters of the SPY-1 radar that might affect fuze function. There are also two states of fuze EM vulnerability with which we are concerned: one in which the fuze power is on and the other in which it is off. This affects the associated SPY-1 max power density. Because the minimum fuze RF turn-on occurs approximately 1000 ft from the ship, the EM environment is more severe with the fuze power off. In developing the maximum power levels expected at the input of the MMIC chips, the RF turn-on was one of the parameters taken under consideration. The other is the MFF out-of-band antenna gain. The MFF antenna gain performance was measured from 500 MHz to 20 GHz. This would provide the needed gain information for all applicable sources of EM energy.

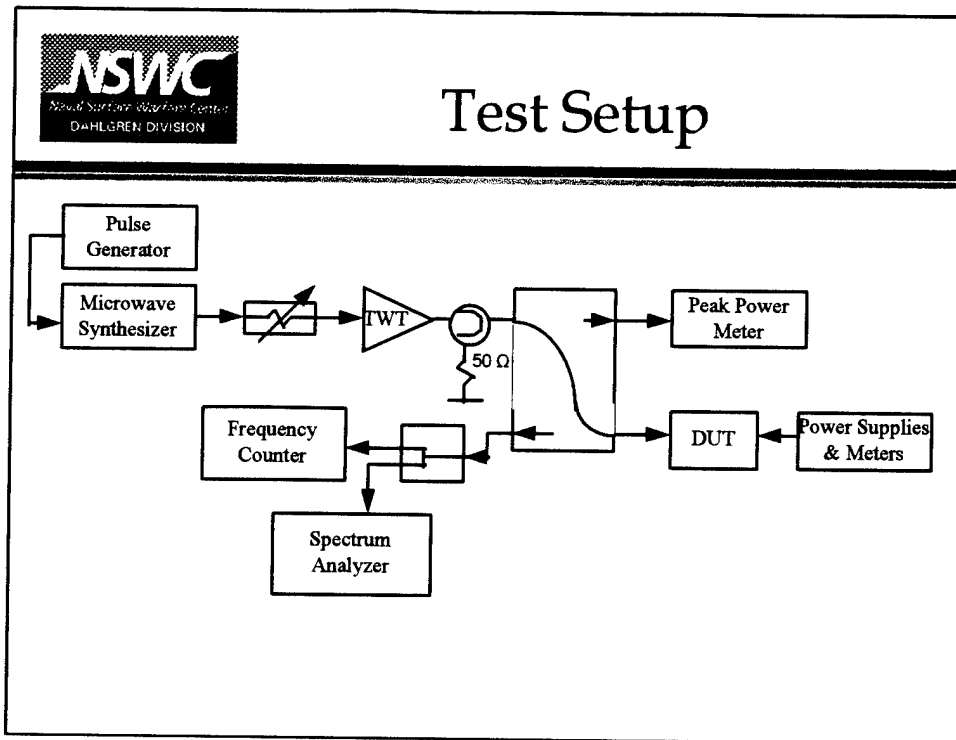

In developing the test configuration, we wanted something simple that did not require a considerable amount of connecting and disconnecting of test equipment. With this setup we can monitor the performance of the device under test (DUT) while we change the input signal - whether that change is a higher power level or a different input waveform.



Test Results

- **Static: > 250 Feet From EMI Source**
- **Dynamic: > 400 Feet From EMI Source**

Using the test setup from the previous page we switched between four different input waveforms. With each of those waveforms we increased the power until we saw a degradation in performance. These tests were run with the MMICs in a static and dynamic mode. The test results indicate that the fuze will not be affected when fuze RF power is off and the fuze is a minimum of 250 ft from the source of EMI. For the dynamic or power-on state, the fuze has to be a minimum of 400 ft from the source.



Conclusions

- Goal Was Met
- MMIC's Can Withstand Required EM Environment

This test setup was not developed to preclude fuze EMV tests. It was developed to cost effectively test the MMIC's at each stage of the development process. That goal was met. A low cost bench-top setup was developed that was easy to configure and simple to run.

The MMIC performance was verified in the EM environment. Degradation can occur, but the fuze must be in close proximity to the EM source. The probability of damage is very low considering the dynamics of the engagement scenario.

DISTRIBUTION

	<u>Copies</u>		<u>Copies</u>
DOD ACTIVITIES (CONUS)		INTERNAL	
ATTN PM4	1	E231	3
NAVAL SURFACE WARFARE CENTER		F43 (F NEWCOMER)	5
CRANE DIVISION		G	1
300 HIGHWAY 361		G30	1
CRANE IN 47522-5001		G31	1
		G32	1
		G33	1
		G34	1
ATTN CODE E29L (TECHNICAL LIBRARY)	1	G34 (J RICHARDSON)	1
COMMANDING OFFICER		G34 (H WENDT)	5
CSSDD NSWC			
6703 W HIGHWAY 98			
PANAMA CITY FL 32407-7001			
DEFENSE TECHNICAL INFORMATION CTR			
8725 JOHN J KINGMAN ROAD			
SUITE 0944			
FT BELVOIR VA 22060-6218	12		
NON-DOD ACTIVITIES (CONUS)			
THE CNA CORPORATION			
P O BOX 16268			
ALEXANDRIA VA 22302-0268	1		
ATTN GIFT AND EXCHANGE DIVISION	4		
LIBRARY OF CONGRESS			
WASHINGTON DC 20540			