



**US Army Corps  
of Engineers**  
Waterways Experiment  
Station

# Design of a High-Resolution, Coded, Portable Radar System

by *Falih H. Ahmad, James A. Evans, Ernest L. Miller*

19960701 095

UNCLASSIFIED//FOR OFFICIAL USE ONLY  
THIS DOCUMENT IS UNCLASSIFIED  
DATE 08-14-2001 BY 60320 UCBAW/SJS/STP

Approved For Public Release; Distribution Is Unlimited

# DISCLAIMER NOTICE

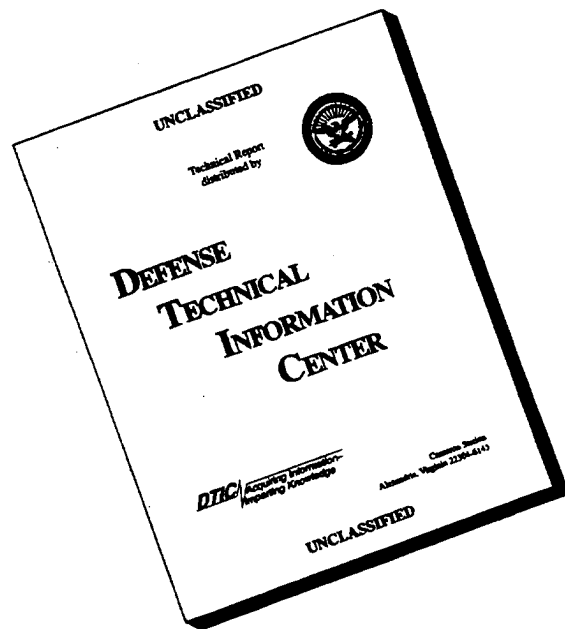

**THIS DOCUMENT IS BEST QUALITY AVAILABLE. THE COPY FURNISHED TO DTIC CONTAINED A SIGNIFICANT NUMBER OF PAGES WHICH DO NOT REPRODUCE LEGIBLY.**

The contents of this report are not to be used for advertising, publication, or promotional purposes. Citation of trade names does not constitute an official endorsement or approval of the use of such commercial products.



PRINTED ON RECYCLED PAPER

Technical Report ITL-96-5  
May 1996

# **Design of a High-Resolution, Coded, Portable Radar System**

by Falih H. Ahmad, James A. Evans, Ernest L. Miller

U.S. Army Corps of Engineers  
Waterways Experiment Station  
3909 Halls Ferry Road  
Vicksburg, MS 39180-6199

**Final report**

Approved for public release; distribution is unlimited

Prepared for Discretionary Research Program  
U.S. Army Engineer Waterways Experiment Station  
3909 Halls Ferry Road, Vicksburg, MS 39180-6199



**US Army Corps  
of Engineers**  
Waterways Experiment  
Station

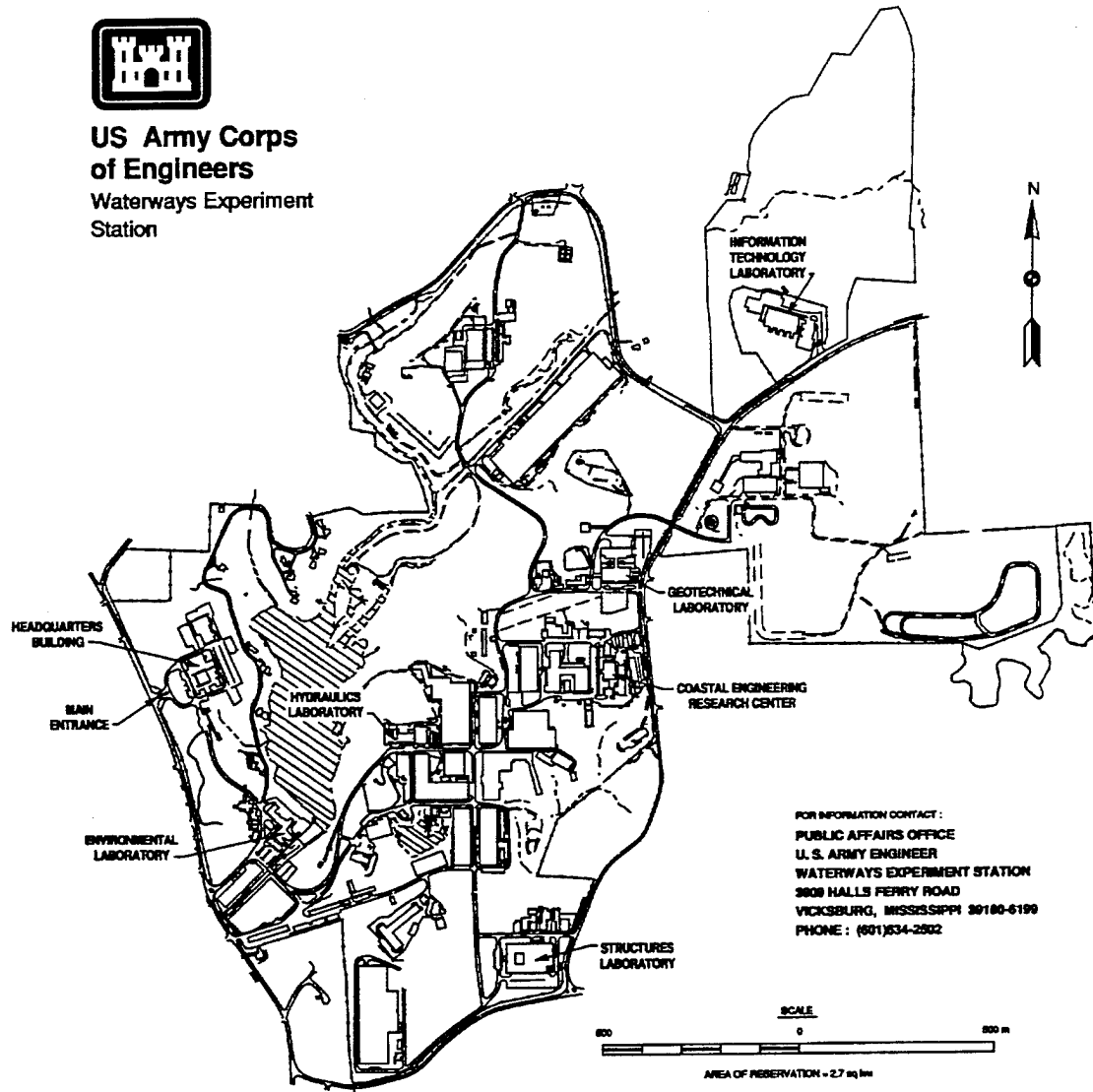

FOR INFORMATION CONTACT :  
PUBLIC AFFAIRS OFFICE  
U. S. ARMY ENGINEER  
WATERWAYS EXPERIMENT STATION  
3808 HALLS FERRY ROAD  
VICKSBURG, MISSISSIPPI 39180-6199  
PHONE : (601)634-2502

### Waterways Experiment Station Cataloging-in-Publication Data

Ahmad, Falih H.

Design of a high-resolution, coded, portable radar system / by Falih H. Ahmad, James A. Evans, Ernest L. Miller ; prepared for Discretionary Research Program, U.S. Army Engineer Waterways Experiment Station.

20 p. : ill. ; 28 cm. — (Technical report ; ITL-96-5)  
Includes bibliographic references.

1. Radar — Technique. 2. Remote sensing. I. Evans, James A. II. Miller, Ernest L. III. United States. Army. Corps of Engineers. IV. U.S. Army Engineer Waterways Experiment Station. V. Information Technology Laboratory (U.S. Army Engineer Waterways Experiment Station) VI. Discretionary Research Program (U.S. Army Engineer Waterways Experiment Station) VII. Title. VIII. Series: Technical report (U.S. Army Engineer Waterways Experiment Station) ; ITL-96-5.  
TA7 W34 no.ITL-96-5

# Contents

---

Preface . . . . .	iv
1—Introduction . . . . .	1
Background . . . . .	1
Scope . . . . .	2
2—System Overview . . . . .	3
Transmitter . . . . .	3
Receiver . . . . .	4
3—System Operation . . . . .	6
4—Circuit Description . . . . .	8
System Controller Assembly . . . . .	8
Transmitter Controller Assembly . . . . .	11
RF Assembly . . . . .	12

SF 298

# Preface

---

This study was conducted under the Discretionary Research Program sponsored by the U.S. Army Engineer Waterways Experiment Station (WES). The work was conducted during the period October 1993 to Spetember 1995.

The research was conducted by Dr. Falih H. Ahmad, Mr. James A. Evans, and Mr. Ernest L. Miller, Instrumentation Systems Development Division, Information Technology Laboratory (ITL), WES, under the general supervision of Dr. N. Radhakrishnan, Director, ITL; and Mr. George P. Bonner, Chief, Instrumentation Systems Development Division.

During the preparation of this report, Dr. Robert W. Whalin was Director of WES. Commander was COL Bruce K. Howard, EN.

This report should be cited as follows:

Ahmad, Falih H., Evans, James A., and Miller, Ernest L. (1996). "Design of a high-resolution, coded, portable radar system," Technical Report ITL-96-5, U.S. Army Engineer Waterways Experiment Station, Vicksburg, MS.

*The contents of this report are not to be used for advertising, publication, or promotional purposes. Citation of trade names does not constitute an official endorsement or approval of the use of such commercial products.*

# 1 Introduction

---

## Background

Radar has been identified and used as a tool for detection and recognition of a variety of targets. Advances in technology have made it possible to generate high-power, wide-band electromagnetic signals such as short-duration impulses in the time domain. A combination of a transmitter and a wide-band receiver that generates such signals provides information over a large range of frequencies at a high rate. It is used to reconstruct the electromagnetic properties of media. This process may be accomplished through the utilization of scattered electromagnetic fields in the time or frequency domain. In this and similar fashions radar is applied to many physical, geophysical, and engineering problems such as nondestructive testing of media. It is desired in the latter application to apply target or pattern recognition for the purpose of identifying objects, defects, or any other kind of targets and discriminate between them and clutter. Due to these applications, a radar system is in demand that provides many desired features such as immunity to noise to prevent data corruption, high-range and cross-range resolutions, light weight, simple operation, noncontact, applicability to remote sensing, portability, and moderate power consumption. Accordingly, much effort has been spent in improving methods used to develop radar systems that would provide such properties in their design. In particular, a high-resolution radar is considered well suited to perform media identification. High resolution in range can be achieved by transmitting a low-peak-power coded pulse of long duration and then compressing on reception. A radar system that incorporates pulse compression processing provides improvement in the detection performance, reduction in the mutual interference, and an increase in the system operational flexibility.<sup>1</sup>

Up to the present time, most carriers used in radar technology have been sinusoidal signals. However, these carriers can be coded or not

---

<sup>1</sup> Jerry L. Eaves and Edward K. Reedy, ed. (1987). *Principles of modern radar*. Van Nostrand Reinhold, New York.

coded depending on the type of radar used. Examples of codes used in high-resolution radar are Barker, Frank, Costas, and Welti.<sup>1</sup> Usually, carriers of ground-penetrating radars are not coded. Most ground-penetrating radars are somewhat portable but not to the extent of being hand held. In some ground-penetrating radars the antenna is designed to slide on the surface of the medium that is being tested. This action limits their applications. A synthetic aperture radar is a high-resolution radar. This radar takes advantage of the forward motion of the airborne radar to produce the equivalent of an array antenna that may be thousands of feet long. Moreover, the beam width of this array is roughly half that of a real array of the same length. The outputs of the array are synthesized in a signal processor from the returns received by the real radar antenna over a period of up to several seconds or more.<sup>2</sup>

## Scope

This report describes the design of a hand-held, portable, microprocessor-controlled, high-resolution radar (HRPR). This report, however, does not include the design of the transmitting and receiving antennas.

---

<sup>1</sup> August W. Rihaczek. (1985). *Principles of high resolution radar*. Peninsula Publishing, Los Altos, CA.

<sup>2</sup> George W. Stimson. (1983). *Introduction to airborne radar*. Hughes Aircraft Company, El Segundo, CA.

## 2 System Overview

---

The high-resolution radar system is designed to be portable, hand held, and microprocessor controlled. The generated carrier is an exponentially decaying sinusoidal wave with a frequency in the GHz range. In this high-resolution radar, analog-to-digital conversion is performed through an integrated circuit chip at a rate of multiple giga samples per second. In addition, digital signal processing is performed and an inversion scheme is embedded in memory chips to generate electromagnetic profiles in real time. In order to achieve high-range resolution, digital codes of certain length such as Barker, Welts, or Frank codes can easily be implemented in this radar system through the application of complementary metal oxide semiconductor (CMOS) logic. The coding of the carrier is made possible through the application of a digitally controlled phase shifter. Power consumption of this high-resolution radar is moderate. Thus, in addition to being hand held, the complete system is mountable on any vehicle as well. As a result, this radar system can be used to perform target and media identification in real time. This process is totally performed by the microprocessor of the system and identification results are displayed visually.

The portable high-resolution radar consists of four parts: a transmitter, a receiver, a microprocessor, and d-c power supply.

### Transmitter

A block diagram of the transmitter is shown in Figure 1. The transmitter includes the following items:

- a. A keypad.
- b. Shift registers.
- c. A carrier generating circuit.
- d. A phase shifter.
- e. A power amplifier.
- f. A transmitting antenna.

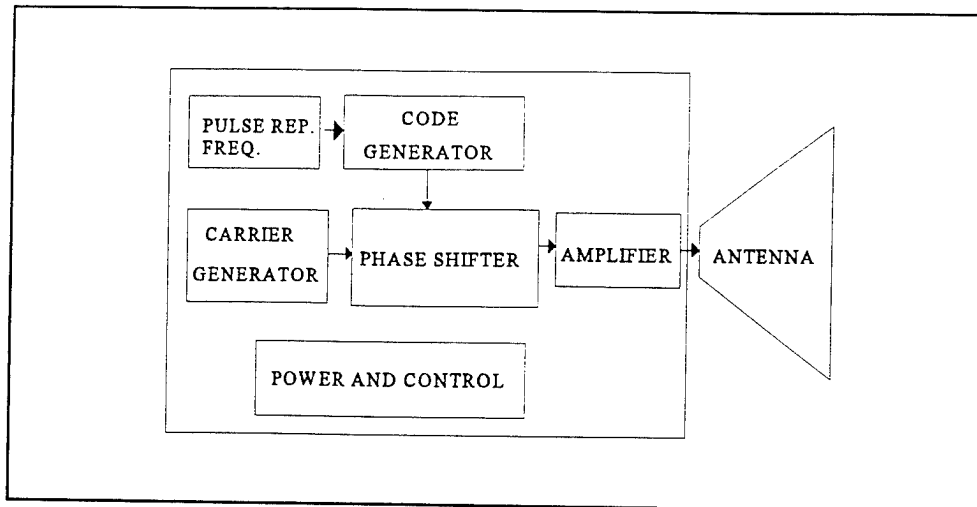

Figure 1. HRPR transmitter

## Receiver

A block diagram of the receiver is shown in Figure 2. The receiver includes the following items:

- a. A receiving antenna.
- b. An envelope detector.
- c. A circuit to generate the complex coefficient of reflection function.
- d. A circuit to perform inversion and generate electromagnetic profiles.
- e. An analog-to-digital (A/D) convertor.
- f. A circuit to perform digital signal processing.

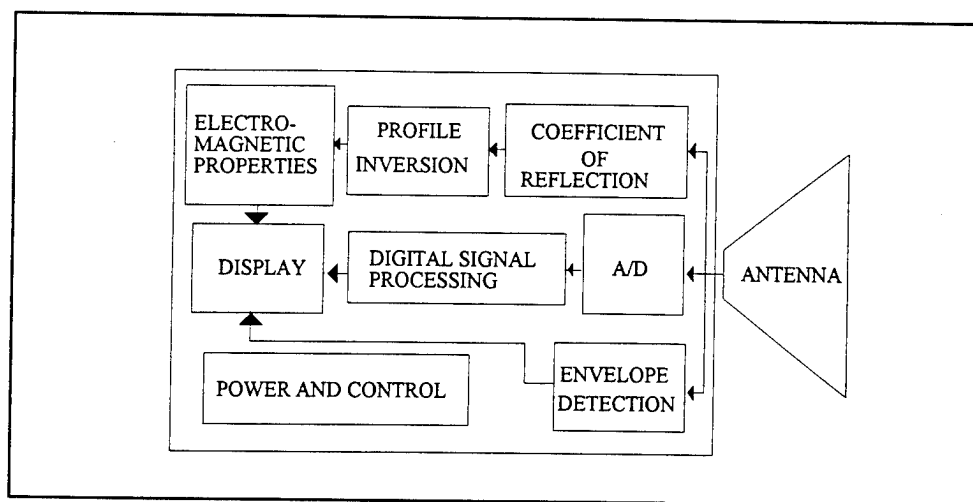

Figure 2. HRPR receiver

Physically, the four parts of the high-resolution radar are configured in two major sections: the electronics section and the antennas section. A conceptual drawing of this configuration is shown in Figure 3.

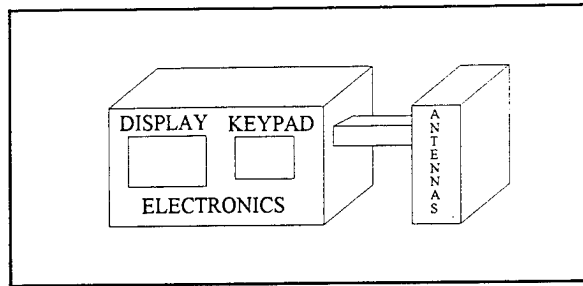

Figure 3. Conceptual configuration of HRPR

As shown in Figure 3, the power supply, system controller, transmitter, and receiver are confined to the electronics section. The antenna section consists of the transmitting and receiving antennas. It is recommended that the antennas be highly directional and of a narrow beam width.

## 3 System Operation

---

The exponentially decaying carrier is generated in the transmitter and its phase is encoded by a code previously selected by the user. The code is specified through the keypad, which is a part of the front panel of the radar system. As the carrier is generated, its phase is encoded by a digitally controlled phase shifter. This process is controlled by commands issued to the phase shifter from the microprocessor. Accordingly, for every bit of the code, the carrier's phase is changed. The duration in time of every bit of the code is much smaller than that of the transmitted carrier. The encoded carrier is amplified with a power amplifier and fed to the transmitting antenna. The returned signal is received by the receiving antenna and three major operations are performed on it:

- a. Envelope detection is used to extract the envelope of the returned carrier and generate a baseband signal characteristic of the target. This is accomplished using a pin diode as an averaging detector.
- b. The detected returned signal is compared to the transmitted in amplitude and phase. The results of this comparison are used to generate the complex reflection coefficient function. This function is then used as an input to a subcircuit in which an inversion is performed. As a result some electromagnetic profiles of the medium such as permittivity, conductivity, permeability, and susceptibility are generated. The inversion scheme is outlined in Ahmad.<sup>1</sup>
- c. The returned signal is digitized using a high-speed analog-to-digital converter. The resulting signal is prepared for digital signal processing.

The outputs from these three operations are utilized to identify the medium under test.

As a general scenario, a medium is chosen to be interrogated. The antennas of the radar are aimed at the medium, the trigger key is depressed, and the encoded transmitted signal launched toward the medium. In order to prevent a ghost phenomenon from appearing in the returned signal at

---

<sup>1</sup> Falih H. Ahmad. (1996). "Approximation of electromagnetic profiles" (in preparation), U.S. Army Engineer Waterways Experiment Station, Vicksburg, MS.

the receiving antenna, an error condition message is displayed on the screen of the radar. This message advises the operator to move back from the interface of the interrogated medium. The HRPR system allows for a minimum distance that separates the interface of the medium from its transmitting antenna. The returned signal is received by the HRPR system and used along with the transmitted signal to generate the reflection coefficient as a function of depth. The inversion scheme outlined in Ahmad<sup>1</sup> utilizes this function to generate approximations of some of the electromagnetic profiles of the interrogated medium. A precalibration will assist the user in identifying the correct profiles.

---

<sup>1</sup> Falih H. Ahmad. (1996). "Approximation of electromagnetic profiles" (in preparation), U.S. Army Engineer Waterways Experiment Station, Vicksburg, MS.

# 4 Circuit Description

---

## System Controller Assembly

The HRPR system is controlled by an 87C550 type embedded microcontroller integrated-circuit chip operating at 12 MHz labeled IC-1 in Figure 4. The operating system memory is a combination of a 27C256 integrated-circuit memory chip of 32 Kbytes labeled IC-3 in Figure 4 and the integrated-circuit memory chip DS1495 which is an additional 8000X8 bits of nonvolatile static random operating system memory labeled IC-6 in Figure 4. The open memory area, that part of the address range which does not have active memory, both program and random access, is decoded on a 4-Kbyte slot. These unused memory slots support the input/output (I/O) devices such as the keypad, display, transmitter, and receiver. The 87C550 was chosen for several reasons: (a) it is constructed using CMOS technology, which requires low power consumption; (b) it has adequate I/O lines that provide adequate interfaces from memory slots to the I/O devices; (c) it is available in a 25-MHz speed, which is adequate for these requirements; (d) it has a built-in analog-to-digital converter and a serial port. The built-in analog-to-digital converter digitizes the radar system diagnostic data while the serial interface allows the use of an external computer for additional data storage and manipulation. In addition to the microcontroller, most other integrated circuits used in the design are CMOS, which contributes to the overall portability of the unit. A real-time clock is included in the HRPR system. This clock is incorporated in IC-6 in Figure 4. It is used for date and time stamping of data.

The microcontroller receives the keypad entries such as code selection and dwell time (dwell time is the amount of time the system idles before retransmitting the code) through 74HC244, which is an eight-input buffer integrated circuit labeled IC-8 in Figure 4. Valid entries, as determined by the microcontroller, are placed by the microcontroller in memory at a location specified by the operating system that resides in the static random access memory. Numbers of keypad entries are latched into the appropriate latches on the transmitter controller board, via the data bus, for setting the code and the dwell time length in seconds. The integrated-circuit latch 74AC373 is used for setting the dwell time (IC-12 in Figure 5). Similar integrated circuits are used to latch the code and the code's bit length

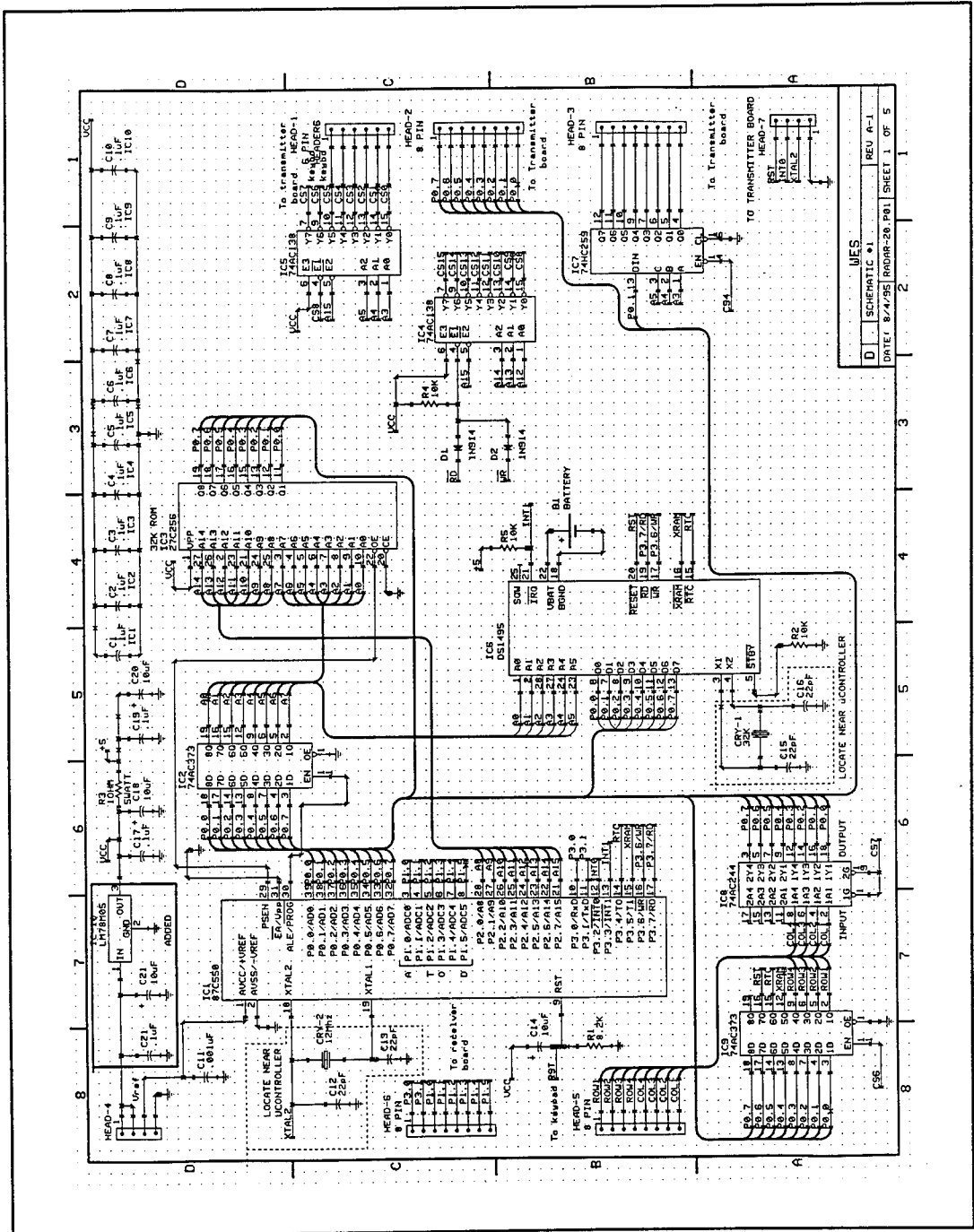

Figure 4. Schematic 1



(labeled IC-3 and IC-4, respectively, in Figure 5). The code's bit length is determined from the code specified by the user.

## Transmitter Controller Assembly

The radar transmitter is controlled by the transmitter controller assembly. This assembly contains the integrated circuit 74AC166 shift registers labeled IC-9 and IC-10 in Figure 5. These shift registers are used for direct loading of the code onto the pulse repetition frequency (PRF) signal. In addition, the transmitter controller assembly contains up/down counters. These counters are used to count up to the code length and dwell time; each is a 74AC169 integrated circuit chip. The up/down counters are labeled IC-5, IC-13, and IC-14 in Figure 5. The transmitter controller assembly also contains digital comparators which are 74AC520 integrated-circuit chips labeled IC-6 and IC-15 in Figure 5. These counters determine when the count-up has reached the proper value for both code length and dwell time.

The transmitter controller assembly accommodates a binary code of a length up to 16 bits. This code is keyed into system memory via the keypad by the user. Several predefined codes are available to the user by keyboard command. For every "ONE" in the code, the phase of the carrier is set to 180 deg with respect to its previous phase; and for every "ZERO" in the code, the phase of the carrier is set to 0 deg with respect to its previous phase. This procedure is outlined in Figure 6.

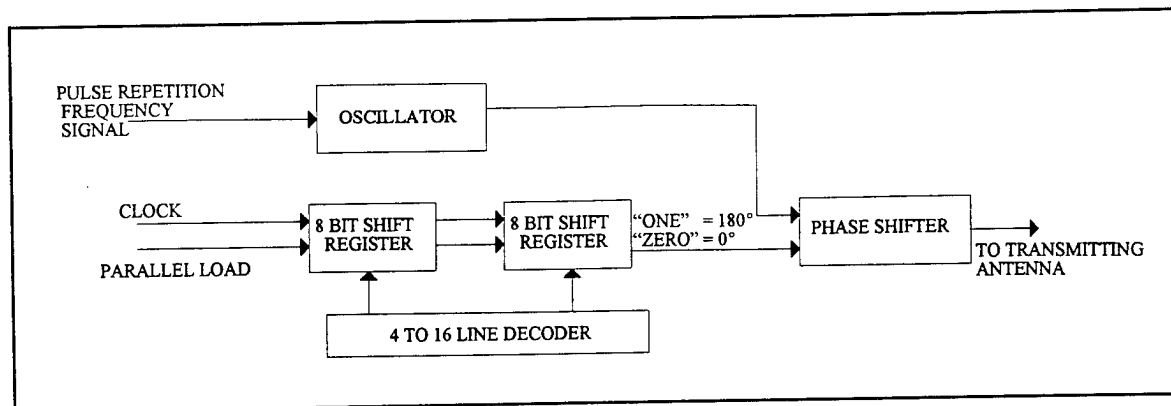

Figure 6. Shift register and phase shift block diagram

The user selects the code and the dwell time by depressing the appropriate keys on the keypad. Consequently the binary equivalent of the code is output via the eight latched outputs from two 74AC373 integrated-circuit chips labeled IC-3 and IC-11 in Figure 5. These outputs are marked as CODE10 through CODE160. The outputs of the latches IC-3 and IC-11 connect to the parallel inputs of the shift registers IC-9 and IC-10 as

shown in Figure 5. At the command issued initially by the microcontroller and after that by the dwell counter comparator output labeled IC-15 in Figure 5, the code is parallel-loaded into the shift registers and clocked out from the serial output to toggle the radio frequency (RF) signal.

The length of the code is represented by the outputs of IC-4 marked CODE1 through CODE4 as shown in Figure 5. The number that represents the "code length" is generated by the system controller assembly's microprocessor from the "CODE" data initially entered through the keyboard. This number in binary form is then loaded into the code length comparator, IC-6, as shown in Figure 5. The counter is preset to zero. Once the counter counts up to the proper code length, the digital comparator turns the dwell time counter on. The dwell time counters IC-13 and IC-14 count up until the pre-entered dwell time value is reached. Once the dwell time value is reached, the output of the dwell comparator IC-15 goes low, which in turn pulls the parallel load line low, which reloads the code into the shift registers again. The value of the dwell time is output by IC-13 and IC-14 and is represented by CODE11 through CODE81 as shown in Figure 5. This value is loaded into memory and can be preset from 0 to 256 periods of PRF. The binary equivalent of this number is used to preset the IC-15 digital comparator, and the code is impressed upon the carrier using an in-phase quadrature phase modulator.

## RF Assembly

The oscillator, when pulsed by the PRF signal, produces an exponentially decaying sinusoidal signal, which is the carrier signal. The circuit of the oscillator is shown in Figure 7. It consists of a voltage amplifier, capacitors, resistors, microstrip lines, and a transistor labeled TR-1. It is an overdamped oscillator that oscillates at a frequency determined by the length of the microstrip line and the various components associated with the circuit. In this design, the frequency will be approximately 1 GHz. Operation of the circuit is as follows: The transistor, in common base configuration, is biased OFF. The transistor turns ON when a differentiated pulse from the PRF signal occurs at its emitter. Once the transistor turns ON, an exponentially decaying sinusoidal signal is generated at a frequency of approximately 1 GHz.

A delay in the PRF signal, when compared to the system clock, is caused by the propagation delays of the shift registers. In order to compensate for this propagation delay, as seen in Figure 7, the resistor labeled R5 in combination with the capacitor labeled Cv allows the PRF signal to be shifted in time. The PRF pulse then goes to the transistor-transistor logic (TTL) input of the in-phase quadrature phase modulator, labeled PS-1 in Figure 7. The TTL input of PS-1 is marked number 14 in Figure 7. The output of the oscillator and the coded PRF signal are input to PS-1 at inputs 14 and 8, respectively. For every pulse in the PRF signal, the phase of the carrier is set in PS-1. This phase is either 0 deg or 180 deg. The

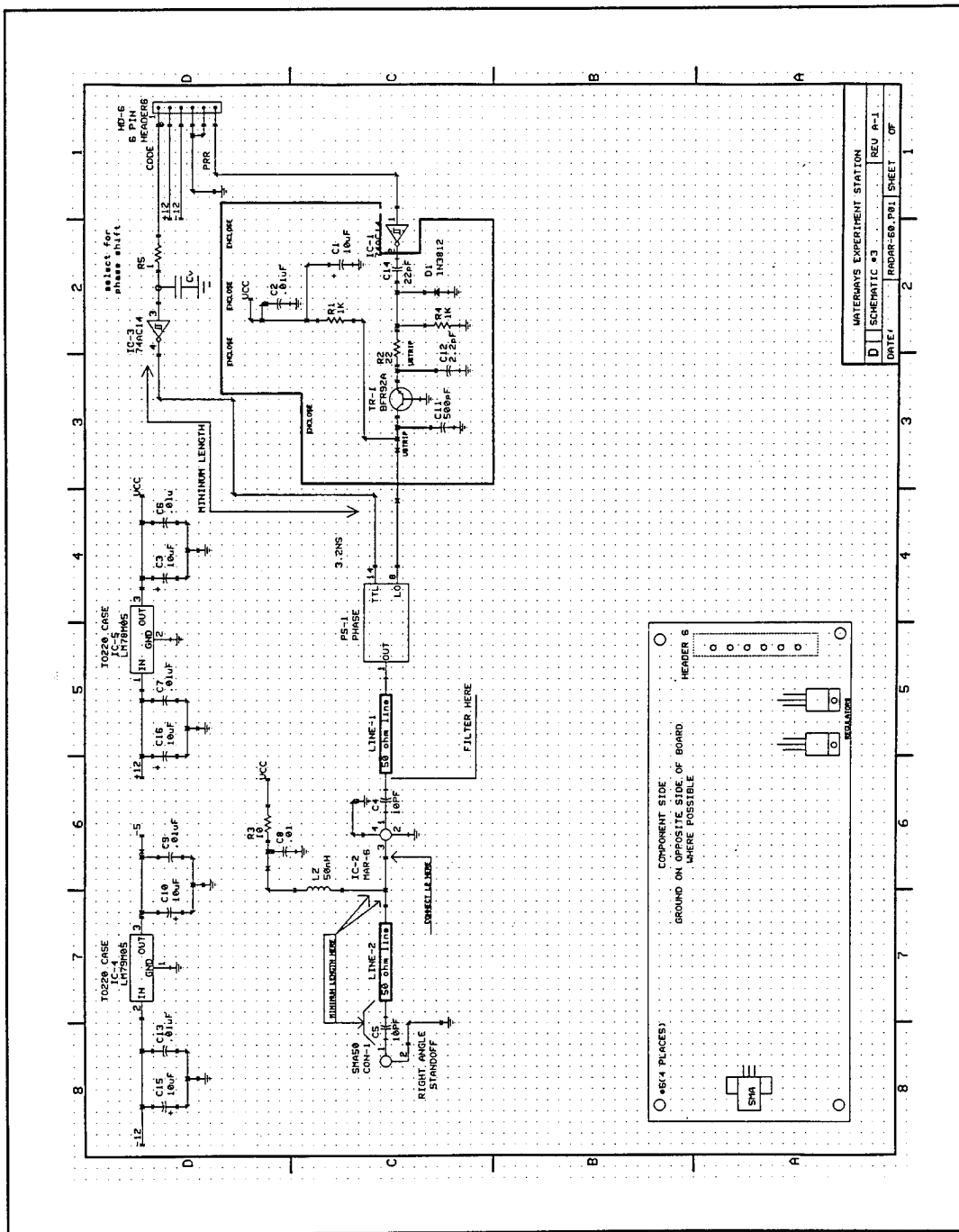
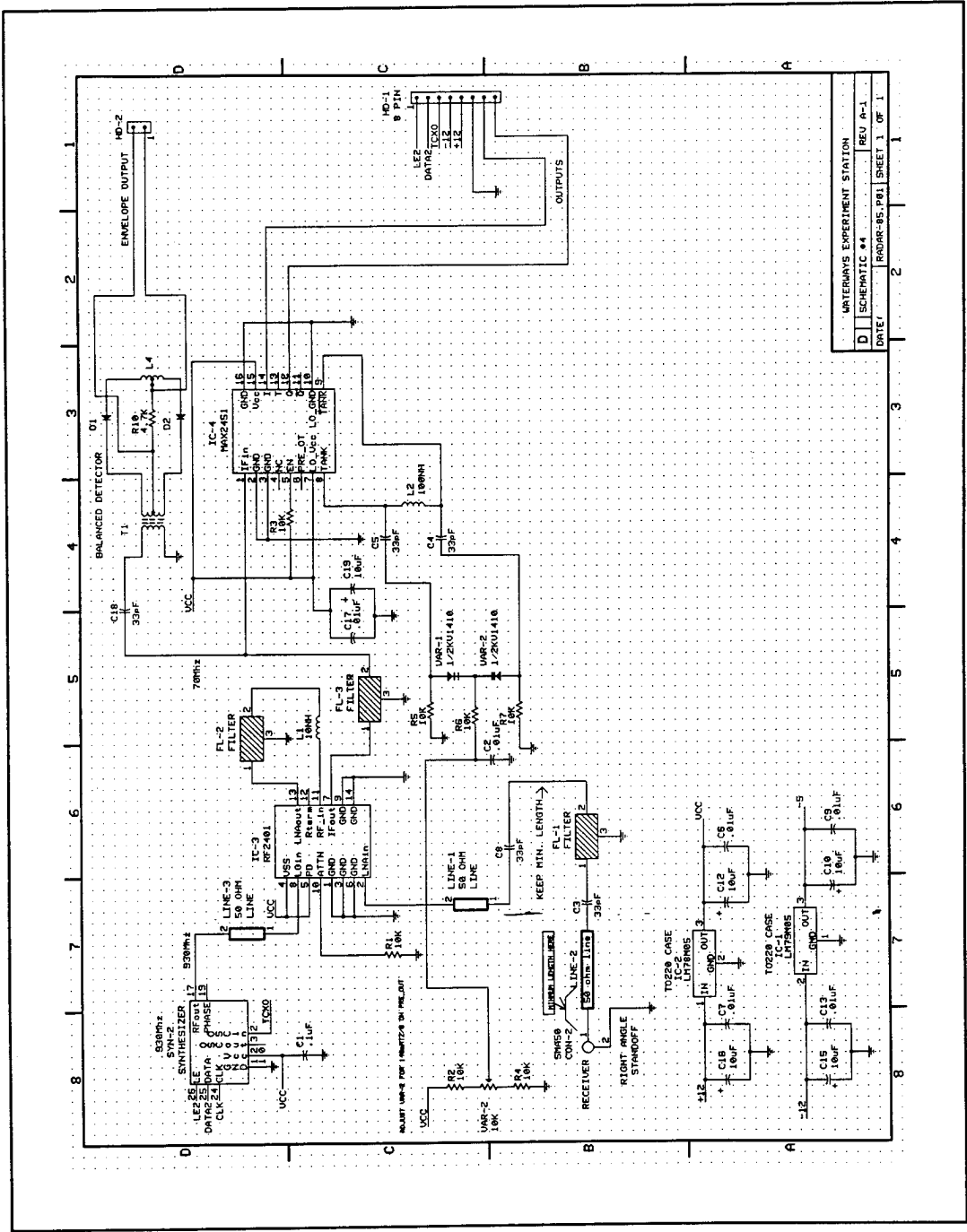

Figure 7. Schematic 3

output of phase shifter PS-1 goes to an amplifier labeled IC-2 in Figure 7, which is a 14-db low-noise preamplifier. The output of the preamplifier is then connected to an off-board power amplifier. The output of the power amplifier is then fed to the transmitting antenna. The reflected signal is returned from the media and received by the receiving antenna.

## Receiver Assembly

As seen from Figure 8, the received signal is filtered by FL-1, which is a bandpass filter. The output of this filter is amplified approximately 12 dB by LNA in IC-3. The output from the amplifier is mixed with a 930-MHz signal, which is produced by SYN-2. The mixing takes place in the mixer stage of IC-3 producing a conversion gain of 21 dB. The output from IC-3, which is on pin 7, is the sum and the difference of the 930-MHz synthesized signal and the 1-GHz received signal. The difference is removed by the bandpass filter FL-3 and the sum is passed on through to the IC-4 demodulator and the balanced phase detector. The balanced phase detector consists of two diodes (D1, D2) and a center-tapped inductor, L4, as well as T1, which is a balanced transformer. The output signal level is available at the envelope output, HD-2. The decoded word is available at HD-1.



15 . Figure 8. Schematic 4

WATERWAYS EXPERIMENT STATION	
D	SCHEMATIC #4
DATE:	RADAR-85, FBI
	SHEET 1 OF 1
	REV A-1

# REPORT DOCUMENTATION PAGE

Form Approved  
OMB No. 0704-0188

Public reporting burden for this collection of information is estimated to average 1 hour per response, including the time for reviewing instructions, searching existing data sources, gathering and maintaining the data needed, and completing and reviewing the collection of information. Send comments regarding this burden estimate or any other aspect of this collection of information, including suggestions for reducing this burden, to Washington Headquarters Services, Directorate for Information Operations and Reports, 1215 Jefferson Davis Highway, Suite 1204, Arlington, VA 22202-4302, and to the Office of Management and Budget, Paperwork Reduction Project (0704-0188), Washington, DC 20503.

1. AGENCY USE ONLY (Leave blank)		2. REPORT DATE May 1996	3. REPORT TYPE AND DATES COVERED Final report	
4. TITLE AND SUBTITLE Design of a High-Resolution, Coded, Portable Radar System			5. FUNDING NUMBERS	
6. AUTHOR(S) Falih H. Ahmad, James A. Evans, Ernest L. Miller				
7. PERFORMING ORGANIZATION NAME(S) AND ADDRESS(ES) U.S. Army Engineer Waterways Experiment Station 3909 Halls Ferry Road, Vicksburg, MS 39180-6199			8. PERFORMING ORGANIZATION REPORT NUMBER Technical Report ITL-96-5	
9. SPONSORING/MONITORING AGENCY NAME(S) AND ADDRESS(ES) Discretionary Research Program U.S. Army Engineer Waterways Experiment Station 3909 Halls Ferry Road, Vicksburg, MS 39180-6199			10. SPONSORING/MONITORING AGENCY REPORT NUMBER	
11. SUPPLEMENTARY NOTES Available from National Technical Information Service, 5285 Port Royal Road, Springfield, VA 22161.				
12a. DISTRIBUTION/AVAILABILITY STATEMENT Approved for public release; distribution is unlimited.			12b. DISTRIBUTION CODE	
13. ABSTRACT (Maximum 200 words) This report describes a hand-held or vehicle-mountable, portable processor based, high-resolution radar system for detecting and identifying an object using high-resolution radar techniques. In particular, the system uses radio waves for identifying a depth and material of an object within a medium. This system can perform target and media identification in real-time. This is achieved by the system's processor where the media identification results can be visually displayed in an output unit. The generated carrier signal used in the system is an exponentially decaying superimposed direct and alternating signal. The frequency of the carrier signal can be in the microwave region. The system performs analog-to-digital (A/D) conversion using integrated circuitry. In addition, Fourier and Hilbert transforms of the observed signal are generated for frequency domain analysis, and profile inversion methodology is applied in this system. To achieve high-resolution results, digital codes such as Barker code or Welty codes are used in the processor. The carrier signal is coded using a digitally controlled phase shifter. Power usage by this radar system is low.				
14. SUBJECT TERMS Coded radar signal High-resolution radar Portable radar			15. NUMBER OF PAGES 20	
			16. PRICE CODE	
17. SECURITY CLASSIFICATION OF REPORT UNCLASSIFIED	18. SECURITY CLASSIFICATION OF THIS PAGE UNCLASSIFIED	19. SECURITY CLASSIFICATION OF ABSTRACT	20. LIMITATION OF ABSTRACT	