

WT-1687

This document consists of 38 pages.

No. 111 of 175 copies, Series A

*Operation*

# HARDTACK

*April - October 1958*

PHASE II

23437

19960702 064

TIMING AND FIRING

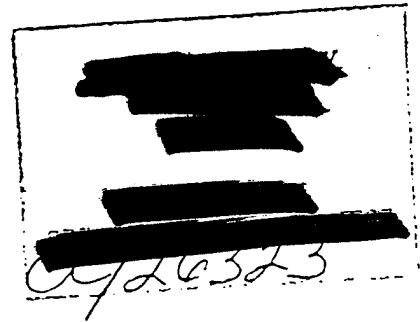

DISTRIBUTION STATEMENT A  
Approved for public release  
Distribution Unlimited

Issuance Date: March 11, 1959

EDGERTON, GERMESHAUSEN & GRIER, INC.  
BOSTON, MASSACHUSETTS, AND  
LAS VEGAS, NEVADA

**UNCLASSIFIED**

CLASSIFICATION CHANGED TO  
AUTHORITY: JOINT DOE/DOD TCG-WT-1  
BY DNA, CHIEF, ISTS

~~This material contains information affecting the national defense of the United States within the meaning of the espionage laws Title 18, U. S. C., Secs. 793 and 794, the transmission or revelation of which in any manner to an unauthorized person is prohibited by law.~~

*John F. Bilsby* DATE *22 Dec 95*



2026

8095

*Arj/48*

[REDACTED]

[REDACTED]

When no longer required, this document may be destroyed in accordance with applicable security regulations.

DO NOT RETURN THIS DOCUMENT

[REDACTED]

[REDACTED]

[REDACTED]

[REDACTED]

[REDACTED]



Defense Nuclear Agency  
6801 Telegraph Road  
Alexandria, Virginia 22310-3398



ISST

18 January 1996

MEMORANDUM FOR DEFENSE TECHNICAL INFORMATION CENTER  
ATTENTION: OCD/Mr. Bill Bush

SUBJECT: Declassification of WT-1687

The Defense Nuclear Agency Security Office (OPSSI) has declassified the following report:

WT-1687  
OPERATION HARDTACK, April-October 1958, Phase II  
Timing and Firing.

In addition, the technical report now is approved for public release.

Since this office shows no record of DTIC ever receiving a copy of this report, we have included a copy for your inclusion at NTIS. This office would appreciate an advance announcement of your accession number, once it is assigned.

Enclosure:  
A/S

*Josephine B. Wood*  
JOSEPHINE B. WOOD  
Chief, Technical Support Branch

DTIC QUALITY INSPECTED 4



Report to the Test Director

TIMING AND FIRING

By  
Staff of Edgerton, Germeshausen & Grier, Inc.

Approved by: Francis I. Strabala

Edgerton, Germeshausen & Grier, Inc.  
Boston, Massachusetts, and Las Vegas, Nevada  
January 1959

~~This material contains information affecting  
the national defense of the United States  
within the meaning of the espionage laws  
Title 18, U. S. C., Secs. 793 and 794, the  
transmission or revelation of which in any  
manner to an unauthorized person is pro-  
hibited by law.~~



ABSTRACT

Edgerton, Germeshausen and Grier, Inc. (EG&G) furnished timing and firing signals for the thirty-seven shots of Operation Hardtack, Phase II.

Six independent timing systems were installed in the CP-1 building and in five timing signal distribution stations at the Nevada Test Site. Signals from the sequence timers were distributed to experimenters and to zero sites by wire; voice-time announcements were transmitted to experimenters on radio frequencies.

The world-time system was operated on surface, tower, and balloon shots and on certain of the underground detonations. Most of the above-ground shots were instrumented for Bhangmeter recording.

CONTENTS

ABSTRACT . . . . . 5

CHAPTER 1 GENERAL PLAN OF OPERATION. . . . . 9

    1.1 Objectives . . . . . 9

    1.2 Procedure . . . . . 9

        1.2.1 General . . . . . 9

        1.2.2 Timing and Firing . . . . . 10

        1.2.3 Timing Circuit . . . . . 10

        1.2.4 Timing Signals . . . . . 10

        1.2.5 Firing System . . . . . 14

        1.2.6 Voice-Time Signals . . . . . 14

        1.2.7 Monitoring . . . . . 14

        1.2.8 Dry Runs . . . . . 14

    1.3 Results . . . . . 14

CHAPTER 2 EQUIPMENT AND INSTALLATIONS. . . . . 17

    2.1 Control Console . . . . . 17

    2.2 Equipment Racks . . . . . 17

    2.3 Rack Description . . . . . 22

    2.4 Timing Distribution Stations . . . . . 23

    2.5 Zero Stations . . . . . 25

CHAPTER 3 COMMUNICATIONS . . . . . 30

    3.1 General. . . . . 30

    3.2 EG&G Communications Net . . . . . 30

    3.3 Voice-Time Nets . . . . . 31

CHAPTER 4 WORLD TIME DETERMINATION . . . . . 32

CHAPTER 5 BHANGMETERS. . . . . 35

ILLUSTRATIONS

CHAPTER 1 GENERAL PLAN OF OPERATION

    1.1 General arrangement of timing system cables. . . . . 11

    1.2 Relationship among timing system elements . . . . . 12

    1.3 Basic timing circuit . . . . . 13

CHAPTER 2 EQUIPMENT AND INSTALLATIONS

2.1 Control console . . . . . 18  
2.2 Power rack, world time rack #1, Area 3 timer rack, Area 3 signal distribution rack, Area 7 timer rack, and Area 7 signal distribution rack . . . . . 19  
2.3 Area F timer rack, Area F signal distribution rack, Area 12B, 12C, and 12F timer and signal distribution rack, and Area 12E and Area 8 timer and signal distribution rack . . . . . 20  
2.4 Area 9 timer rack, Area 9 signal distribution rack, and world time rack #2. . . . . 21  
2.5 Interior view of timing distribution station 351 . . . . . 24  
2.6 Zero rack type SA9A installed for Hamilton shot . . . . . 26  
2.7 Schematic diagram of LASL zero rack type SA8A . . . . . 27  
2.8 Schematic diagram of UCRL zero rack type SA9A . . . . . 28

CHAPTER 4 WORLD TIME DETERMINATION

4.1 World time clock type TD-3. . . . . 33

TABLES

CHAPTER 1 GENERAL PLAN OF OPERATION

1.1 Detonation Summary . . . . . 16

CHAPTER 2 EQUIPMENT AND INSTALLATIONS

2.1 Timing Station Relationship to Overall System . . . . . 25

CHAPTER 3 COMMUNICATIONS

3.1 Communications Networks Used on Hardtack Phase II . . . . . 30

CHAPTER 4 WORLD TIME DETERMINATION

4.1 World Time Summary . . . . . 34

CHAPTER 5 BHANGMETERS

5.1 Bhangmeter Results . . . . . 36



## Chapter 1

### GENERAL PLAN OF OPERATION

#### 1.1 OBJECTIVES

EG&G was responsible for fulfilling the following objectives on Operation Hardtack, Phase II:

1. To provide experimenters with accurate wire timing signals on all dry runs and on all detonations.
2. To provide all users with a voice countdown, synchronized to the timing sequence.
3. To provide firing circuits for the detonation of all shots.
4. To furnish personnel as members of the arming and firing parties.
5. To monitor by wire all information necessary to establish the readiness of the devices and of important experiments.
6. To determine the time of detonation with respect to WWV.
7. To determine a preliminary yield figure, when practicable, from Bhangmeter records for all detonations.
8. To furnish zero racks and associated control equipment for each detonation.
9. To provide blast monitoring of certain underground detonations.

#### 1.2 PROCEDURE

##### 1.2.1 General

The large number of shots to be detonated within the time limit imposed on Phase II of Operation Hardtack and the frequent dry runs necessary for each shot made a multiple timing and firing system imperative. The new system designed for Phase I had demonstrated its capability at the Eniwetok Proving Ground, and the same equipment was to be employed at the Nevada Test Site.

The EPG timing and firing equipment was shipped to Nevada on a priority basis. The first air shipment left Bikini Atoll early in July. The last shipments were made following the concluding shot at Eniwetok Atoll (August 18). Less than a month later, the initial shot of the new series was detonated.

The four standard hard-wire systems which timed and fired the LASL and UCRL shots at EPG were kept intact, and very little modification was necessary for the NTS installation. Components from the other Phase I systems (Johnston Island and DOD underwater) were utilized to assemble two more systems. All Phase II systems were identical in operation.

Whereas the previous NTS timing systems required a separate pair of lines for each timing signal, the Hardtack system was designed to transmit all timing signals to the

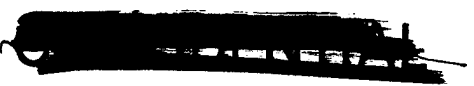

distribution station over a single pair of lines. This feature greatly facilitated the installation at the test site ~~Complex~~ Complex, in most cases, was sufficient to carry the timing signals for all six systems.

Arm, fire, and monitor signals were transmitted over separate cables to each zero site with the exception of the Area 12 tunnel sites where it was necessary to use a 51-pair cable. Figure 1.1 shows the general arrangement of cables.

### 1.2.2 Timing and Firing

Timing, control, and distribution equipment, comprising six independent systems, furnished timing, arm, and fire signals for the thirty-seven shots of Phase II. The six systems served four areas in Yucca Basin, one in Frenchman Flat and four tunnel sites underneath the mesa.

A block diagram showing the relationship of timing system, distribution station and zero site is given in Fig. 1.2.

The independent systems made it possible to set up for several shots at one time and to dry run them individually, as needed. Any or all of the shots could be fired as soon as readiness was determined.

### 1.2.3 Timing Circuit

Figure 1.3 illustrates the basic timing circuit. The sequence timer employs two stepping switches which advance at a rate synchronized with the world time system. Each position of the stepping switch corresponds to a definite point in time. The desired times for the signal sequence are obtained by connecting patch cords from the appropriate contacts on the stepping switch to the master signal relay. At the selected time, a short pulse is transmitted to the signal decoder at the signal distribution station. In the decoder, a signal repeater relay, actuated by these pulses, advances the decoder stepping switch one position for each timing pulse. Each contact on the stepping switch is patched to a separate relay where the timing pulse is converted to a steady timing signal and distributed through isolated circuits to signal relays at each experimenter's station. All signals are cut off at  $\pm 1$  sec.

### 1.2.4 Timing Signals

The Hardtack sequence timer could provide up to twenty-four timing signals for general usage. These signals could be selected at any half-minute interval from -60 min. to -2 min., and at any half-second interval from -2 min. to  $\pm 1$  sec. Signals could easily be selected or changed by proper positioning of patchcords in the plugboard on the face of the coder and decoder. On most shots, approximately 18 timing signals were transmitted; however, special signals could be added as needed for individual shots. The basic sequence is enumerated below:

-60 min.	-3 1/2 min.	-30 sec.	-1 sec.
-30 min.	-3 min.	-15 sec.	-1/2 sec.
-15 min.	-2 min.	- 5 sec.	Zero Test
-10 min.	-1 min.	-2 1/2 sec.	$\pm 1$ sec.
- 5 min.		-1 1/2 sec.	

Signals transmitted for special requirements in addition to the basic sequence included -45 min., -25 min., -4 sec., -2 sec., and  $\pm 1/2$  sec signals. The system cut off automatically at  $\pm 1$  sec.

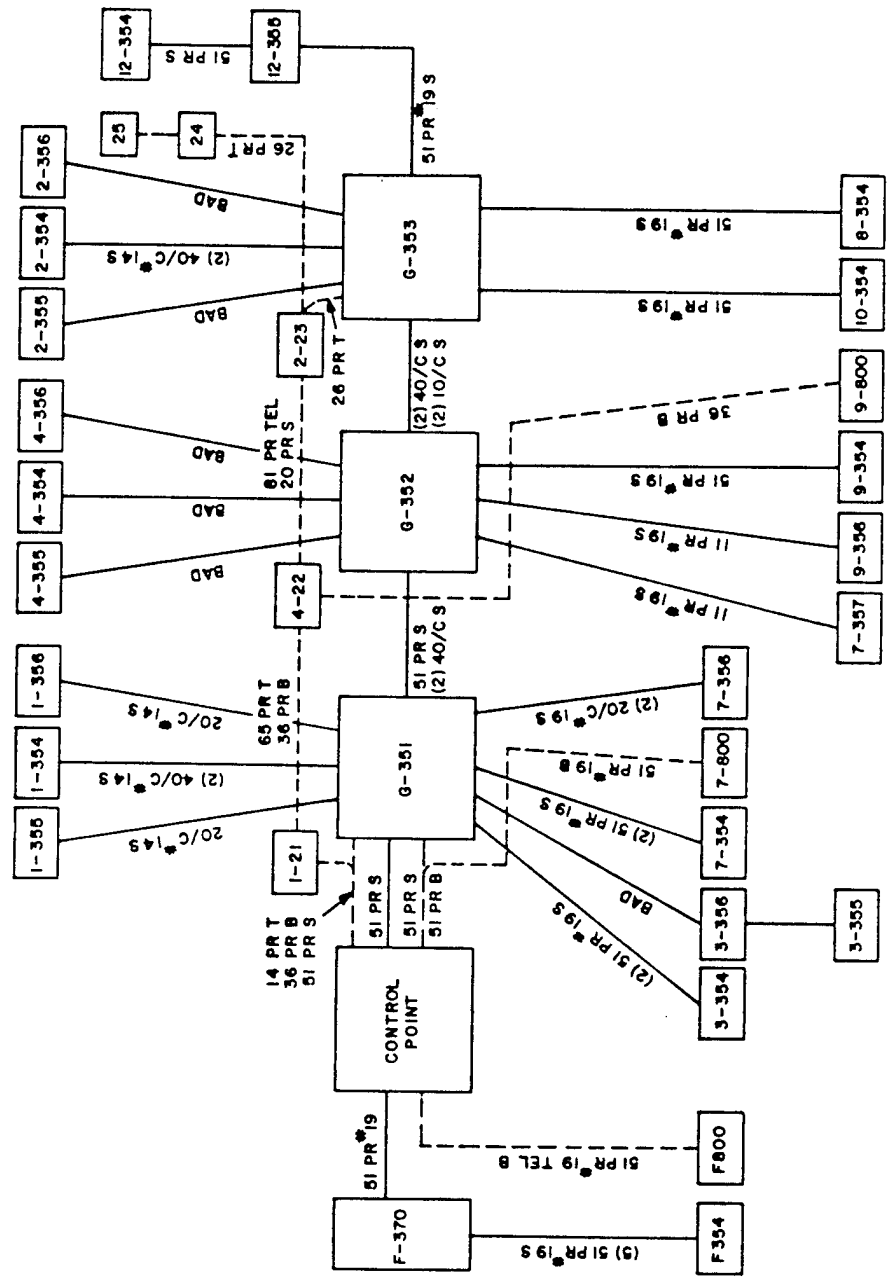

Fig. 1.1 - General arrangement of timing system cables

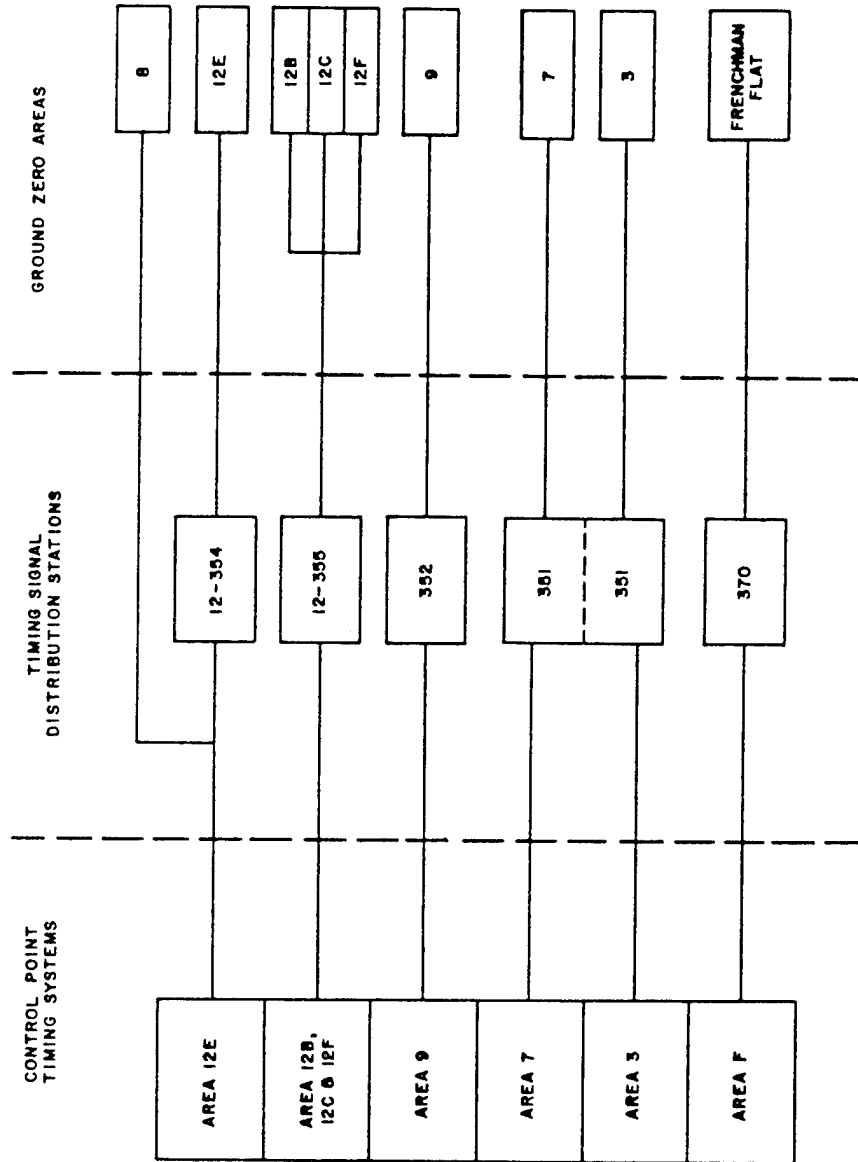

Fig. 1.2 - Relationship among timing system elements

**CONFIDENTIAL**

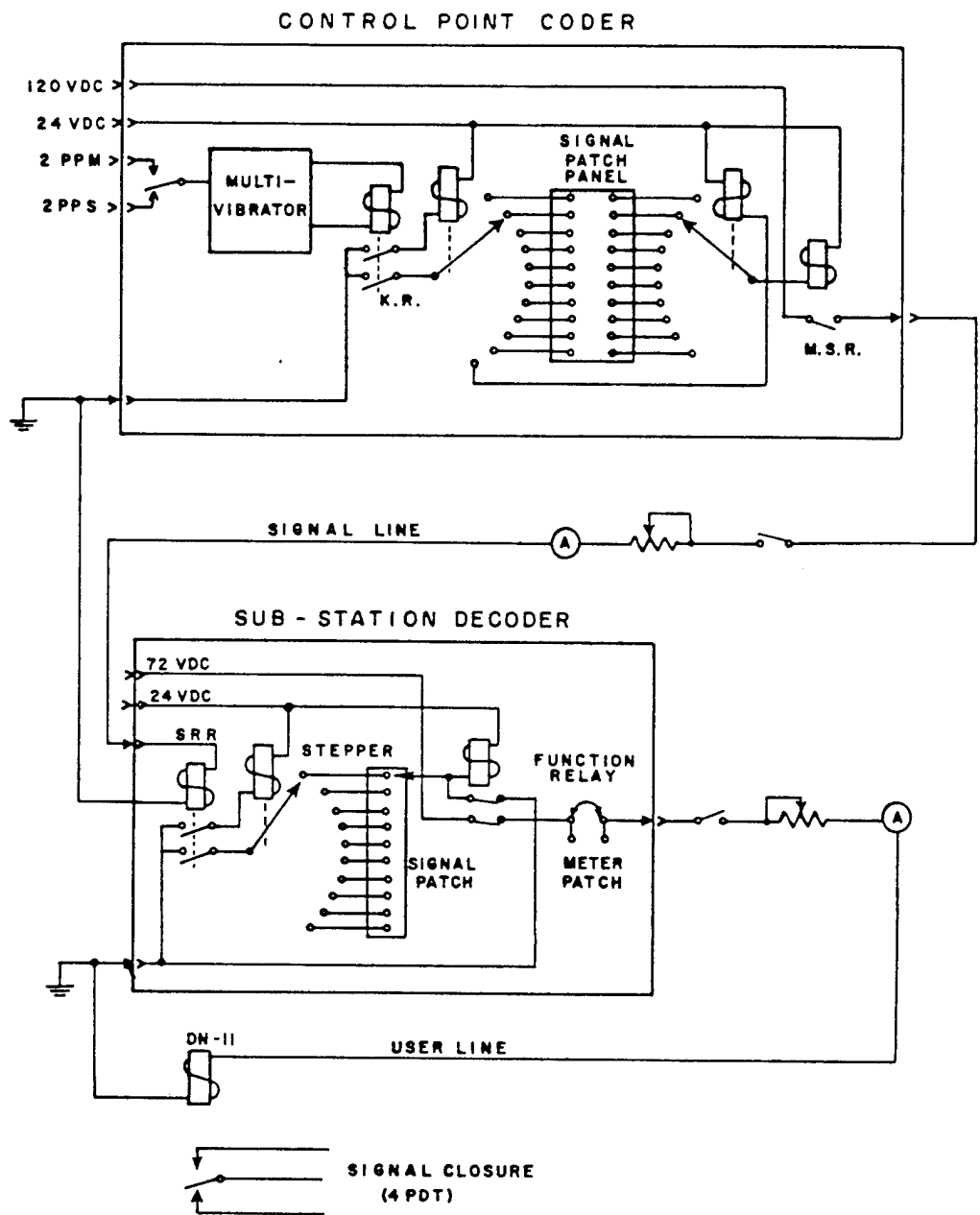

Fig. 1.3 - Basic timing circuit

### 1.2.5 Firing System

Arm and fire signals were wired directly from the CP to the zero points. Although these transmission lines generally passed through the signal distribution stations, they were isolated from the station circuitry.

Interlocks in the firing line for important experiments were located in the timing station racks; interlocks for functions crucial to the firing of the device itself were located in the zero rack.

### 1.2.6 Voice-Time Signals

No voice-time signals were transmitted automatically on this phase of the operation; all countdowns were given live by the console operator. Because of the rush nature of the operation, the Ampex tape equipment could not be set up in time for the first shots. As the operation progressed, it became apparent that the enormous number of dry runs, many of which overlapped, together with numerous short delays, would have made the operation of automatic voice-time equipment difficult.

Since installation time was at a premium, no radio tone system was installed. The demand for radio tones was at a minimum, and hardwire circuits were, for the most part, available.

### 1.2.7 Monitoring

Lack of time prevented installation of the Hammarlund tone-telemetering system used on Plumbbob and Hardtack, Phase I; therefore, all monitoring was accomplished directly by individual wire pairs. Functions monitored at the CP included those at the zero site - the arm relay, fire relay, load-ring high voltage, and high voltage to the zippers; and the position of the decoder stepping switch at the signal distribution station. On shots where the reaction history was measured, the voltage to the alpha station was monitored. Other special functions were monitored according to the requirements for the individual shots.

### 1.2.8 Dry Runs

Several dry runs for each shot were conducted to establish the proper operation of the timing and firing system and to provide users with an accurate signal sequence to ready their experiments. At least one full-power dry run was included for assurance that none of the timing or power circuits were overloaded. Full-frequency runs were generally held to make certain that all radio interference had been eliminated.

During the extent of the Nevada operation, over 250 dry runs were conducted, ranging from 1 to 18 runs per shot.

## 1.3 RESULTS

The timing and firing systems operated satisfactorily and proved themselves equal to the tight schedule. Only one notable failure occurred in the timing system; on the final run for Shot Logan a tube burned out in the sequence timer, causing the stepping switch to advance erratically and to transmit signals ahead of schedule. The emergency stop switch, provided for such contingencies, was utilized to interrupt the sequence.

The shots detonated by each system are listed in Table 1.1, along with the date, time, zero location, and the number of dry runs prior to each shot. Of the 37 shots, 29 shots

were fired in the month of October, including a record number of 17 shots in the last eight days of the operation. On October 22, four shots were fired in slightly over ten hours. Although Shot Adams was held in firing readiness until the moratorium deadline, it could not be fired because of weather conditions.

Table 1.1 - DETONATION SUMMARY

<u>Shot</u>	<u>Agency</u>	<u>Date</u>	<u>Time</u>	<u>Location</u>	<u>No. Of Dry Runs</u>
<u>Area 3 Timing System</u>					
Otero	LASL	Sept. 12	1200	U-3q	8
Bernalillo	LASL	Sept. 17	1130	U-3n	7
Luna	LASL	Sept. 21	1100	U-3m	8
Valencia	LASL	Sept. 26	1200	U-3r	7
Colfax	LASL	Oct. 5	0815	U-3k	7
Rio Arriba	LASL	Oct. 18	0825	T-3s	3
San Juan	LASL	Oct. 20	0630	U-3p	7
Catron	LASL	Oct. 24	0700	T-3t	3
Chaves	LASL	Oct. 27	0630	T-3u	5
Humboldt	UCRL	Oct. 29	0645	T-3v	4
<u>Area 7 Timing System</u>					
Eddy	LASL	Sept. 19	0600	B-7b	4
Mora	LASL	Sept. 29	0605	B-7b	6
Hidalgo	LASL	Oct. 5	0610	B-7b	12
Quay	LASL	Oct. 10	0630	T-7c	5
Lea	LASL	Oct. 13	0520	B-7b	8
Dona Ana	LASL	Oct. 16	0620	B-7b	3
Socorro	LASL	Oct. 22	0530	B-7b	8
DeBaca	LASL	Oct. 26	0800	B-7b	7
Santa Fe	LASL	Oct. 29	1900	B-7b	6
<u>Area 9 Timing System</u>					
Vesta	UCRL	Oct. 17	1500	S-9e	3
Rushmore	UCRL	Oct. 22	1540	B-9a	10
Juno	UCRL	Oct. 24	0801	S-9f	2
Mazama	UCRL	Oct. 29	0320	T-9d	7
Ganymede	UCRL	Oct. 30	0300	S-9g	2
<u>Area F Timing System (Frenchman Flat)</u>					
Hamilton	UCRL	Oct. 15	0800	T-F1	13
Wrangell	UCRL	Oct. 22	0850	B-Fa	13
Sanford	UCRL	Oct. 26	0220	B-Fa	8
Adams	UCRL	not detonated		B-Fa	4
<u>Area 12E Timing System</u>					
Logan	UCRL	Oct. 15	2200	U-12e.02	9
Oberon	UCRL	Oct. 22	1230	T-8a	2
Ceres	UCRL	Oct. 25	2000	T-8b	8
Bianca	UCRL	Oct. 30	0700	U-12e.05	4
Titania	UCRL	Oct. 30	1234	T-8c	1
<u>Area 12B and F Timing System</u>					
Mercury	UCRL	Sept. 23	1400	U-12f.01	18
Mars	UCRL	Sept. 27	1600	U-12f.02	10
Tamalpais	UCRL	Oct. 8	1400	U-12b.02	11
Neptune	UCRL	Oct. 14	1000	U-12c.03	6
Evans	UCRL	Oct. 28	1600	U-12b.04	8

## Chapter 2

### EQUIPMENT AND INSTALLATIONS

#### 2.1 CONTROL CONSOLE

The control panels for the six timing systems and for the communications system were mounted in the seven-section control console shown in Fig. 2.1. From left to right are the control panels for the Area 12E and 8 system, the Area 12B, 12C and 12F system, the Area 9 system, the Frenchman Flat system, communications, the Area 7 system, and the Area 3 system.

All the timing system control panels were identical in operation. The Area 12E panel clock, which had been used for the Johnston Island events, differed slightly in appearance, but not in operation. Each control panel included a time-of-day clock, a time-to-zero indicator, sequence-start and emergency-stop switches, sequence timer stepping-rate indicators, and a bank of monitor lights for timing signals, arm and fire signals, interlocks, and zero site power.

From the communications panel, the timing system operator could send voice-time announcements over either of two or both voice-time nets and control the distribution of these announcements over the REECO (Reynolds Electrical and Engineering Company), AOC (Air Operations Center), and EG&G nets. The operator could also communicate with EG&G stations in the field over the EG&G net alone. An inter-office communication system was provided for EG&G offices in the CP area.

Four boom-type microphones over the console served the communication system. The two microphones on the left were used for four timing systems. On the right, one microphone was for the exclusive use of the EG&G net, and the other for voice time announcements for the other two timing systems.

Two "Blast Indicators", one for each area 12 timing system, were mounted on the control console. The purpose of this indicator was simply to provide an immediate means of determining that a tunnel device had been detonated. The indicator consisted of a neon bulb connected by a high-impedance line to batteries which were placed on the device at the tunnel site. The neon light remained lit until the explosion broke the circuit. The blast indicator was used on all tunnel shots and on Juno, a surface shot in Area 9.

#### 2.2 EQUIPMENT RACKS

Thirteen racks in a room adjacent to the control room contained all the timing and control equipment for the six timing systems. Figures 2.2 through 2.4 show the appearance and arrangement of the racks.

Two world-time systems synchronized to the same WWV audio signal were included in the control center. To avoid overloading and to provide back-up capability the several

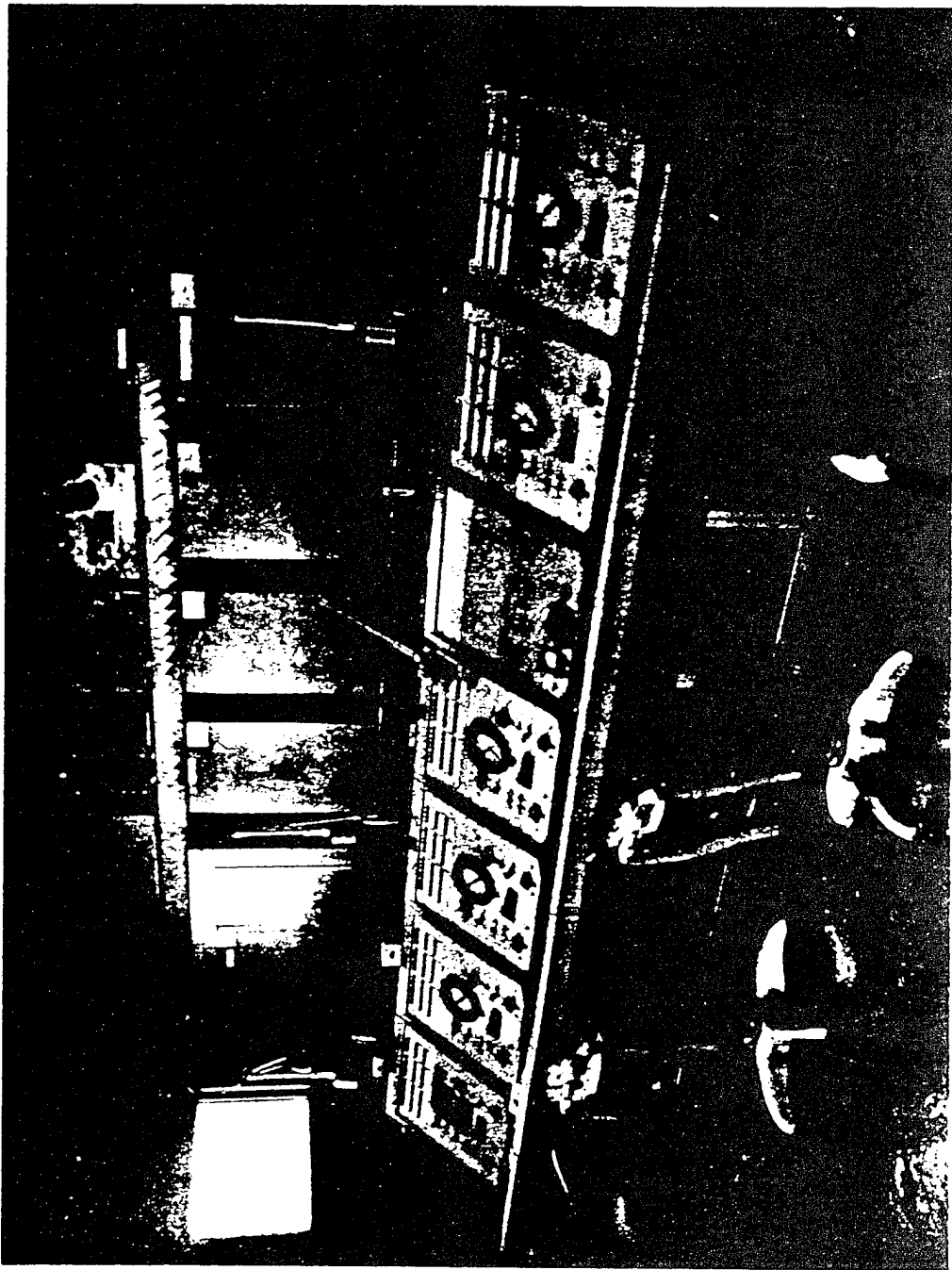

Fig. 2.1 - Control console

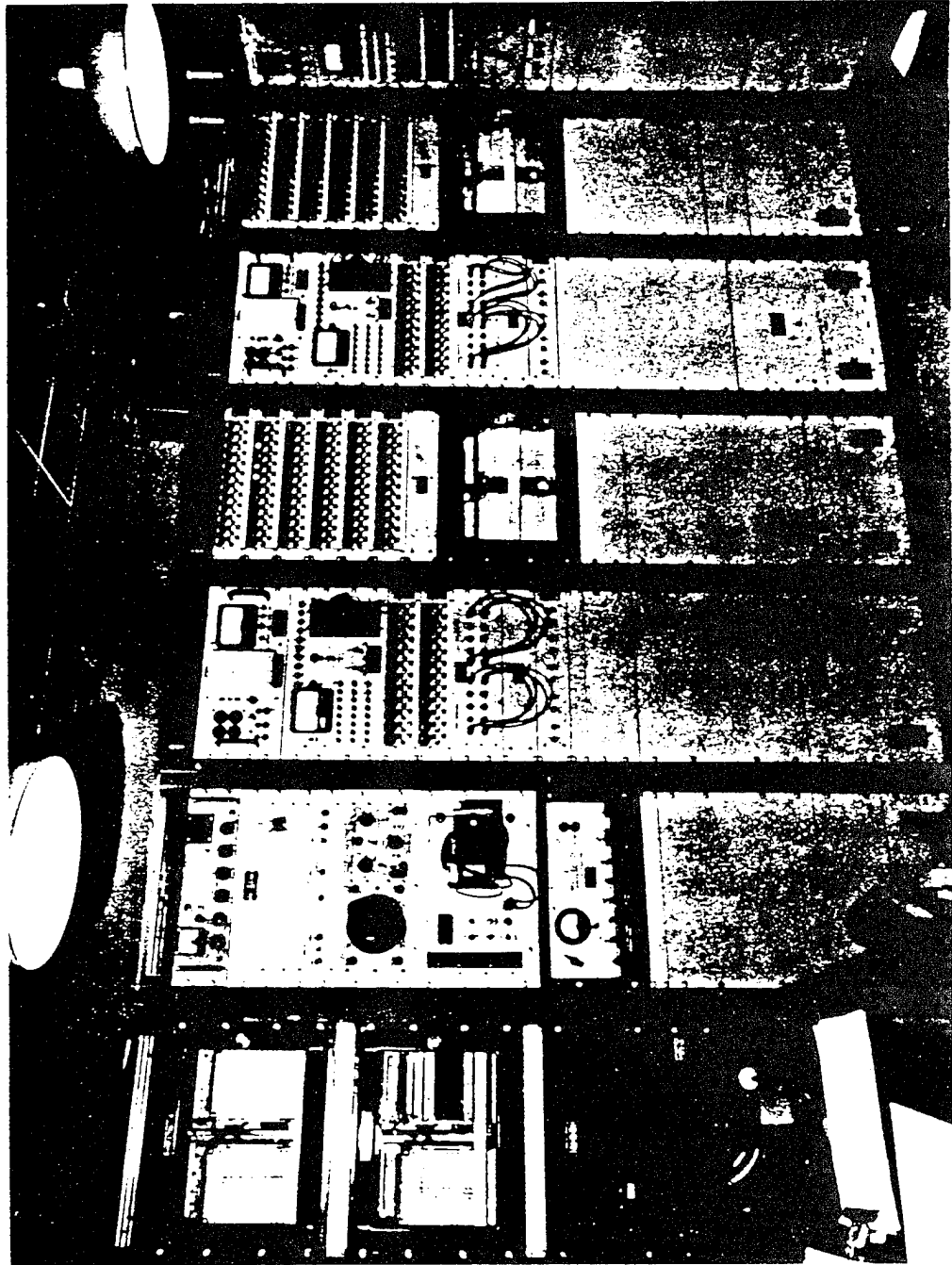

Fig. 2.2 - Power rack, world time rack #1, Area 3 timer rack, Area 3 signal distribution rack, Area 7 timer rack, and Area 7 signal distribution rack

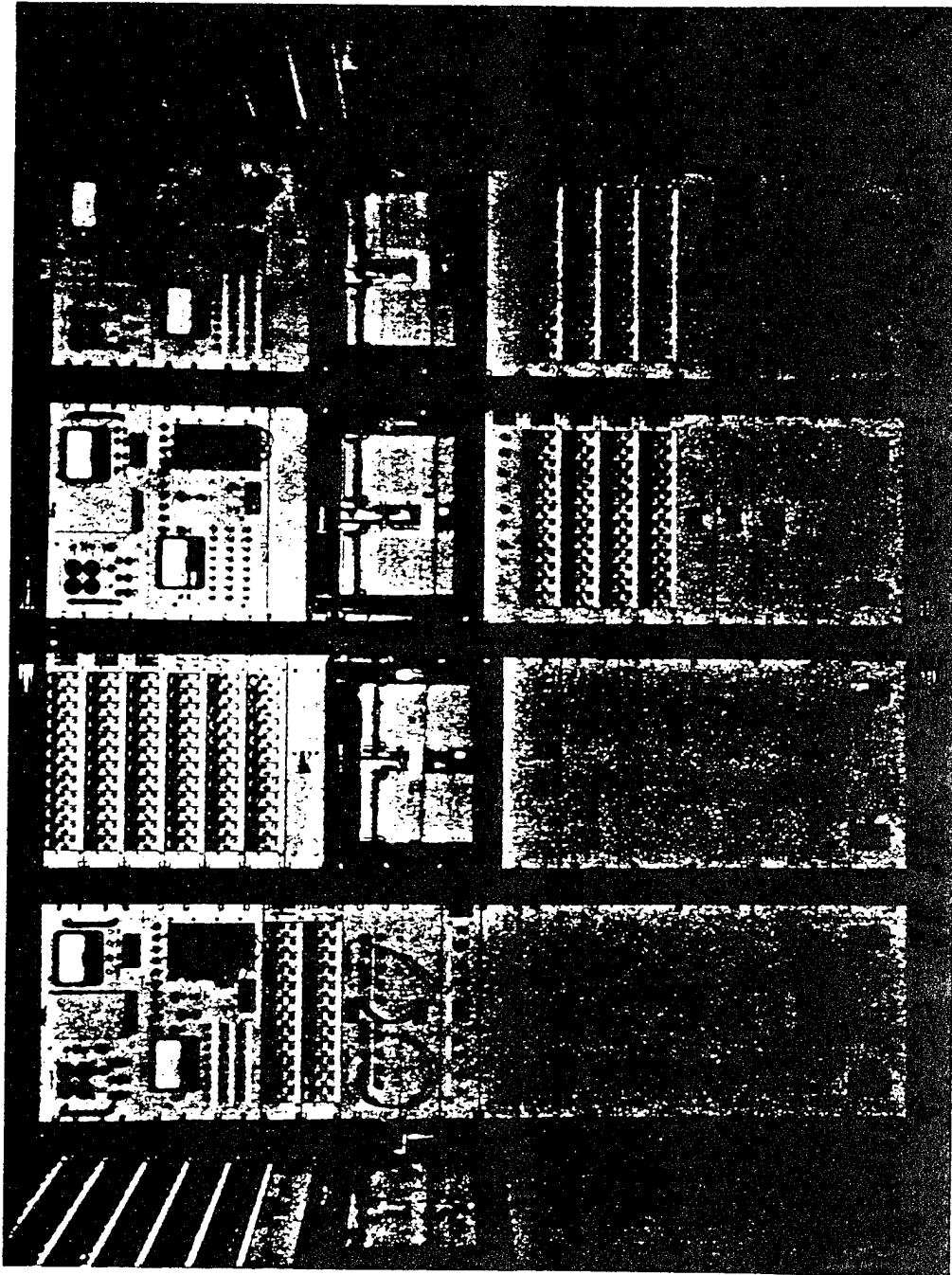

Fig. 2.3 - Area F timer rack, Area F signal distribution rack, Area 12B, 12C, and 12F timer and signal distribution rack, and Area 12E and Area 8 timer and signal distribution rack

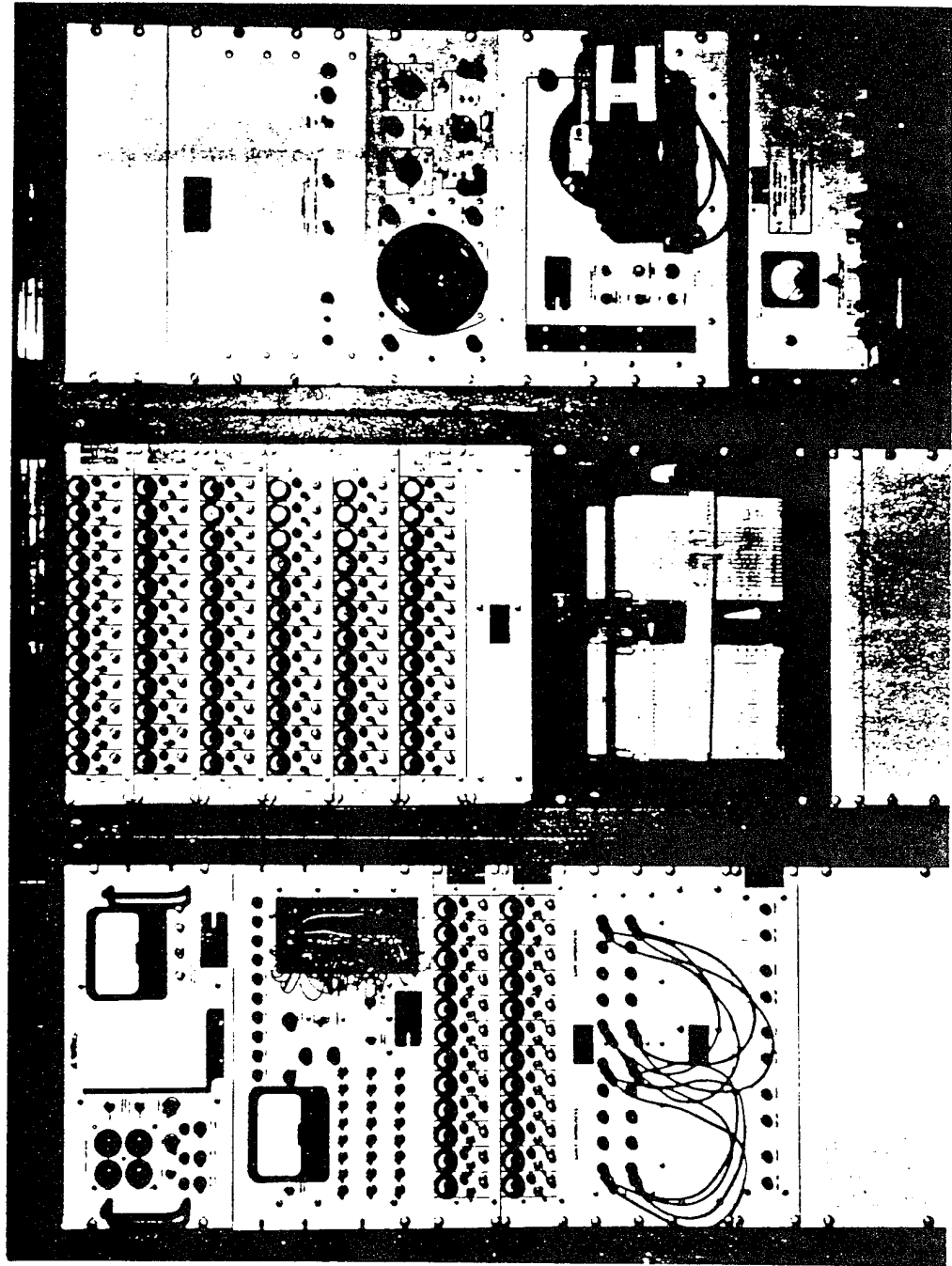

Fig. 2.4 - Area 9 timer rack, Area 9 signal distribution rack, and world time rack #2

functions of the world time system were divided between the two racks. In one instance, the power supply which drives the time-of-day clocks on the consoles failed to operate properly on a live run; however, the time-to-zero indicators were driven from an identical unit in the other rack, and the voice countdown continued without interruption.

### 2.3 RACK DESCRIPTION

Components of the individual racks are listed below.

#### Power Rack

Two Esterline-Angus twin-unit strip-chart recorders for monitoring timing system power: 120 v-ac, 120 v-dc, and 24 v-dc.

General Radio Multivibrators and Power Supply Unit, Model 1102A

General Radio Piezo-Electric Oscillators, Model 1101A

#### World Time Rack No. 1

Beckman-Berkeley WWV Receiver, Model 905

EG&G World Time Synchronizer, Type SN-1

Hewlett-Packard Oscilloscope, Model 120A

EG&G World Time Clock, Type TD-3

Brush Regulated-Frequency Power Supply, Model BL809

#### Area 3 Timer Rack

EG&G Stepping-Switch Sequence Timer, Type SA-4

EG&G CP Signal Decoder, Type SA-5A

Two EG&G 12-meter Signal Distribution Control Units, Type SA-2

EG&G Interlock Relay Panel, Type RE-1

EG&G Relay Panel, Type RE-2

EG&G Decoder Ready Indicator, Type RE-3

EG&G Emergency-Stop Relay Panel, Type RE-4

#### Area 3 Timing Signal Distribution Rack

Six EG&G 12-meter Signal Distribution Control Units, Type SA-2

EG&G Relay Panel, Type RE-2

Esterline-Angus 40-pen strip chart recorder for monitoring timing system functions

#### Area 7 Timer Rack

Identical to the area 3 Timer Rack

#### Area 7 Timing Signal Distribution Rack

Identical to the area 3 Distribution Rack

#### Area F Timer Rack

Identical to the area 3 Timer Rack

#### Area F Timing System Distribution Rack

Identical to the area 3 Distribution Rack

#### Area 12B, 12C and 12F Timer and Signal Distribution Rack

EG&G Stepping-Switch Sequence Timer, Type SA-4

EG&G Signal Decoder, Type SA-5A

Esterline-Angus 40-pen Strip Chart Recorder

EG&G Decoder Ready Indicator, Type RE-3

Four EG&G 12-meter Signal Distribution Control Units, Type SA-2

Two EG&G Relay Panels, Type RE-2

EG&G Emergency-Stop Relay Panels, Type RE-4

Area 12E and Area 8 Timer and Distribution Rack

Identical to the above rack except that it had only one RE-2 Relay Panel and no Decoder Ready Indicator (both area 12 systems used the same Decoder Ready Indicator in the above rack).

Area 9 Timer Rack

Identical to the area 3 Timer Rack

Area 9 Signal Distribution Rack

Identical to the area 3 Distribution Rack

World Time Rack No. 2

EG&G Time Synchronizer, Type SN-1

Hewlett-Packard Oscilloscope, Model 120A

EG&G World Time Clock, Type TD-3

Brush Regulated Frequency Power Supply, Model BL-809

General Radio Multivibrators and Power Supply, Model 1102A

General Radio Piezo-Electric Oscillator, Model 1101A

The bottom panel in each rack contained two switches for supplying a-c/d-c power to the rack components.

#### 2.4 TIMING DISTRIBUTION STATIONS

Timing signals generated by the sequence timers were distributed to local experimenters from racks in the CP-1 building and from racks in three distribution stations in the Yucca Flat Area, one in the Frenchman Flat Area, and two near the tunnel sites. The stations in the Yucca and Frenchman areas were reinforced concrete structures; the other two stations were of the brockhouse type. The timing station associated with each system is given in Table 2.1. Figure 2.5 shows the interior of Station 351. The components of the individual racks shown in Fig. 2.5 are listed below.

Area 3 System (Rack No. 1)

Two 12-meter Signal Distribution Panels

EG&G Signal Decoder, Type SA-5

Interlock Relay Patch Panel, Type RE-1

12-meter Signal Distribution Panel

Area 3 System (Rack No. 2)

Three 12-meter Signal Distribution Panels

40-pen Esterline-Angus Strip-Chart Recorder

EG&G Net Transceiver

Relay Panel

AC-DC Rack Power Switch Panel

Area 7 System (Rack No. 3)

Three 12-meter Signal Distribution Panels

40-pen Esterline-Angus Strip Chart Recorder

EG&G Battery Charger, Type PS-3

AC-DC Rack Power Switch Panel

Area 7 System (Rack No. 4)

Three 12-meter Signal Distribution Panels

EG&G Signal Decoder, Type SA-5

Interlock Relay Patch Panel, Type RE-1

Signal Distribution Control Unit, Type SA-2

Cam Timer for Special  $\neq$  30 sec and  $\neq$  3 min. Zero Site Signals

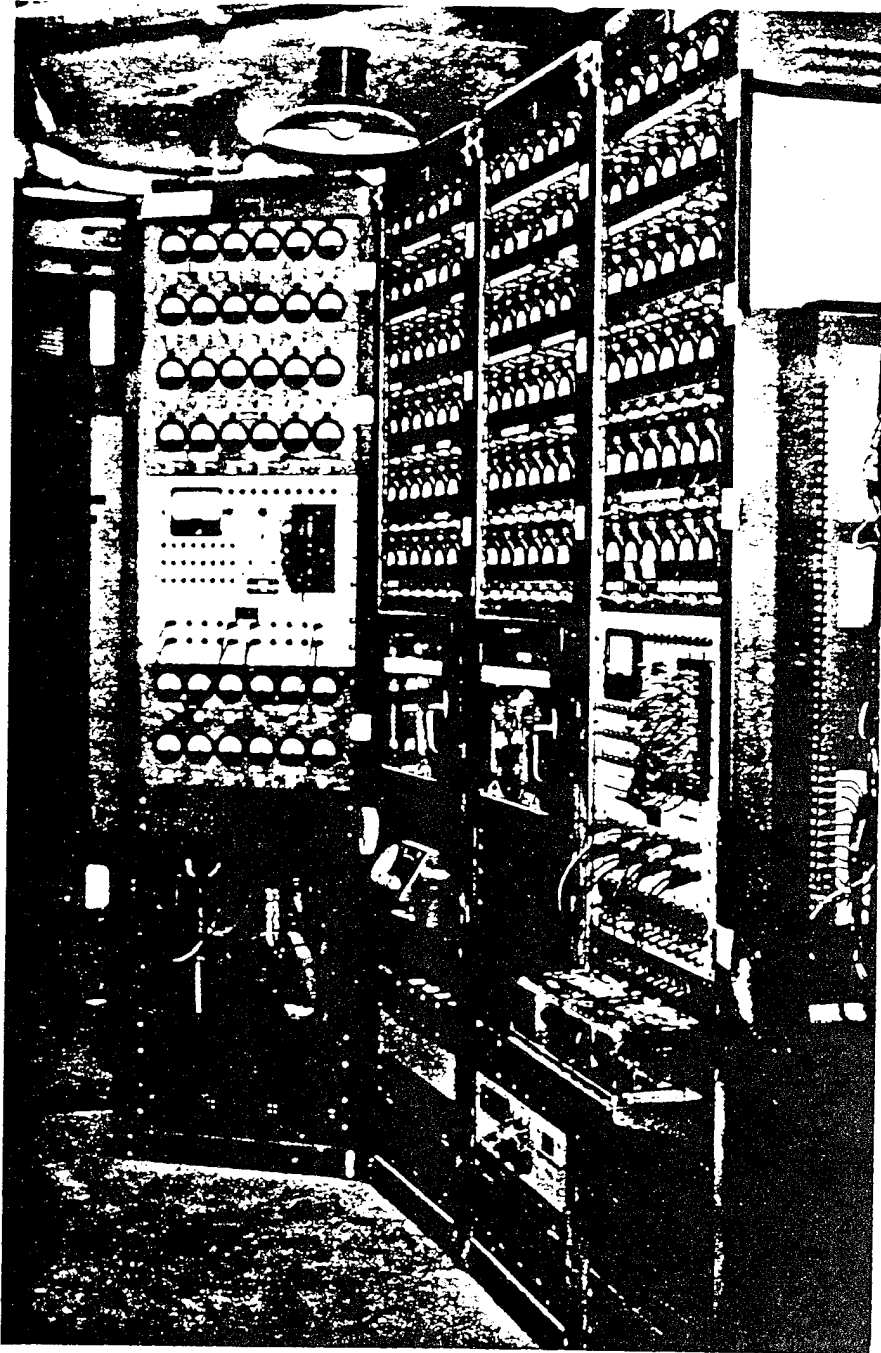

Fig. 2.5 - Interior view of timing distribution station 351

Table 2.1 - TIMING STATION RELATIONSHIP TO OVERALL SYSTEM

Station No.	Coordinates	Timing System Served
CP-1	N 795,802 E 679,153	All Systems
351	N 842,782 E 678,806	Area 3 Area 7
352	N 855,151 E 675,271	Area 9
12-354	N 887,750 E 637,850	Area 12E
12-355	N 889,730 E 636,900	Areas 12B, 12C and 12F
370	N 747,159 E 705,242	Area F

Each timing station contained two racks of equipment except Station 351, which had two racks for the Area 3 System and two for the Area 7 System. The racks for each system housed an EG&G Signal Decoder, Type SA-5. Additional equipment included an Esterline-Angus 40-pen strip chart recorder for monitoring timing signals and other functions, several 12-meter distribution panels of the Plumbbob type, and an EG&G net transceiver. The NTS power system furnished a-c power to these stations; d-c power was obtained from a bank of lead-acid batteries in each station.

## 2.5 ZERO STATIONS

EG&G provided a zero rack for each device detonated in the Phase II series. The functions of the zero racks are as follows:

1. to supply the high-voltage
2. to arm the X-unit and zipper circuits
3. to interlock the various circuits to insure a proper sequence of operation
4. to apply power to the "fire" solenoid
5. to provide the circuitry necessary to monitor these functions from the Control Point.

The zero racks fabricated for this phase of the operation differed only slightly from those employed on Phase I. The dehumidifier and the control racks were eliminated and the unit was enclosed in a suitcase type container.

Two types of zero racks were used, Type SA-8A for LASL shots and Type SA-9A for UCRL shots. Figure 2.6 shows a UCRL type rack installed for Hamilton shot. Both units have the same basic components, although the electrical wiring varied in some respects according to user requirements. A detailed description of the operation of these racks is given in EG&G Report No. B-1783. Figures 2.7 and 2.8 are schematic diagrams of the two types of racks.

EG&G supplied 18 Type SA-8A and 15 Type SA-9A. As the operation progressed, the number of shots added to the original schedule exhausted the supply of new zero racks; consequently, spare zero racks from Phase I and from Operation Plumbbob were put

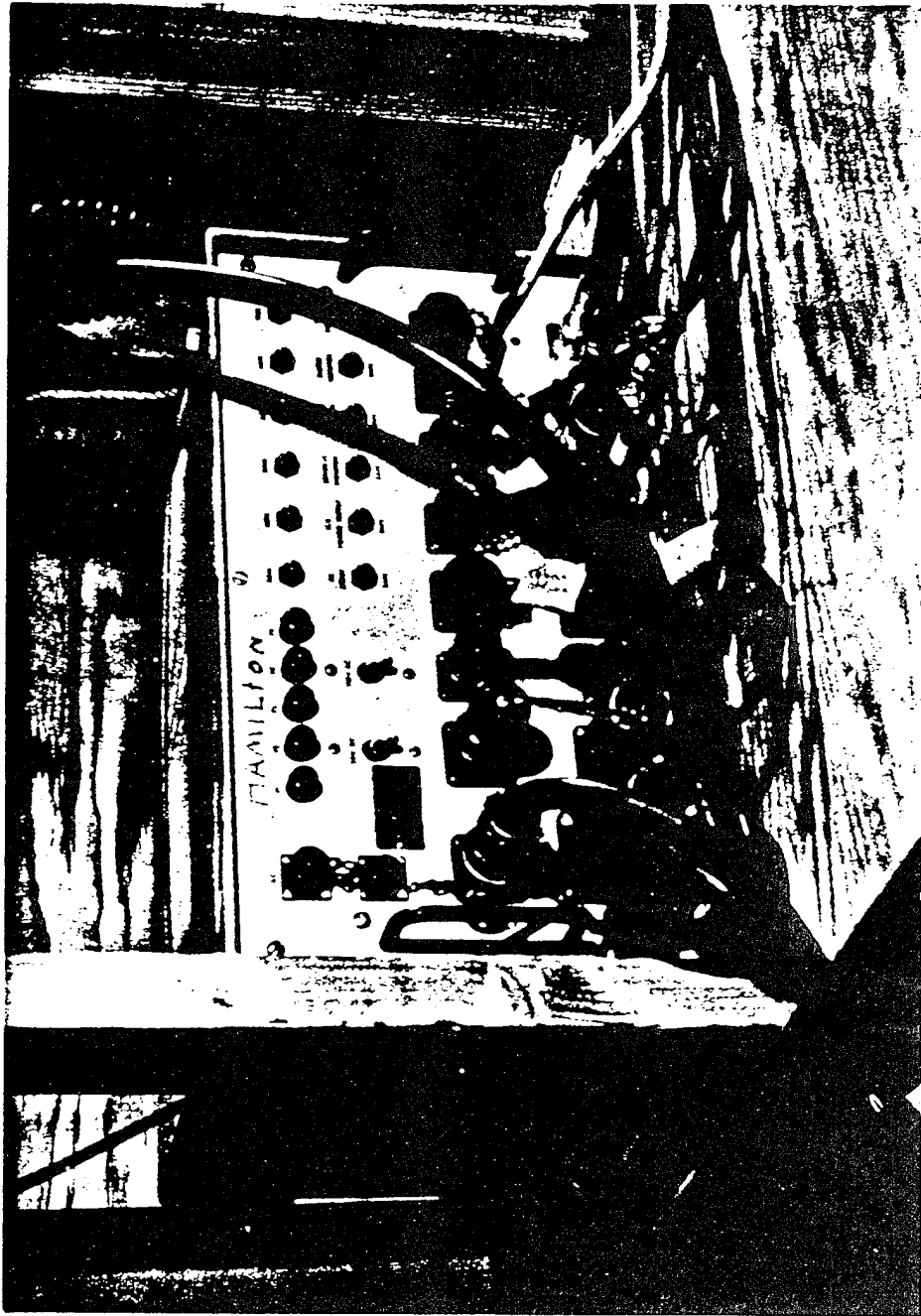

Fig. 2.6 - Zero rack type SA9A installed for Hamilton shot



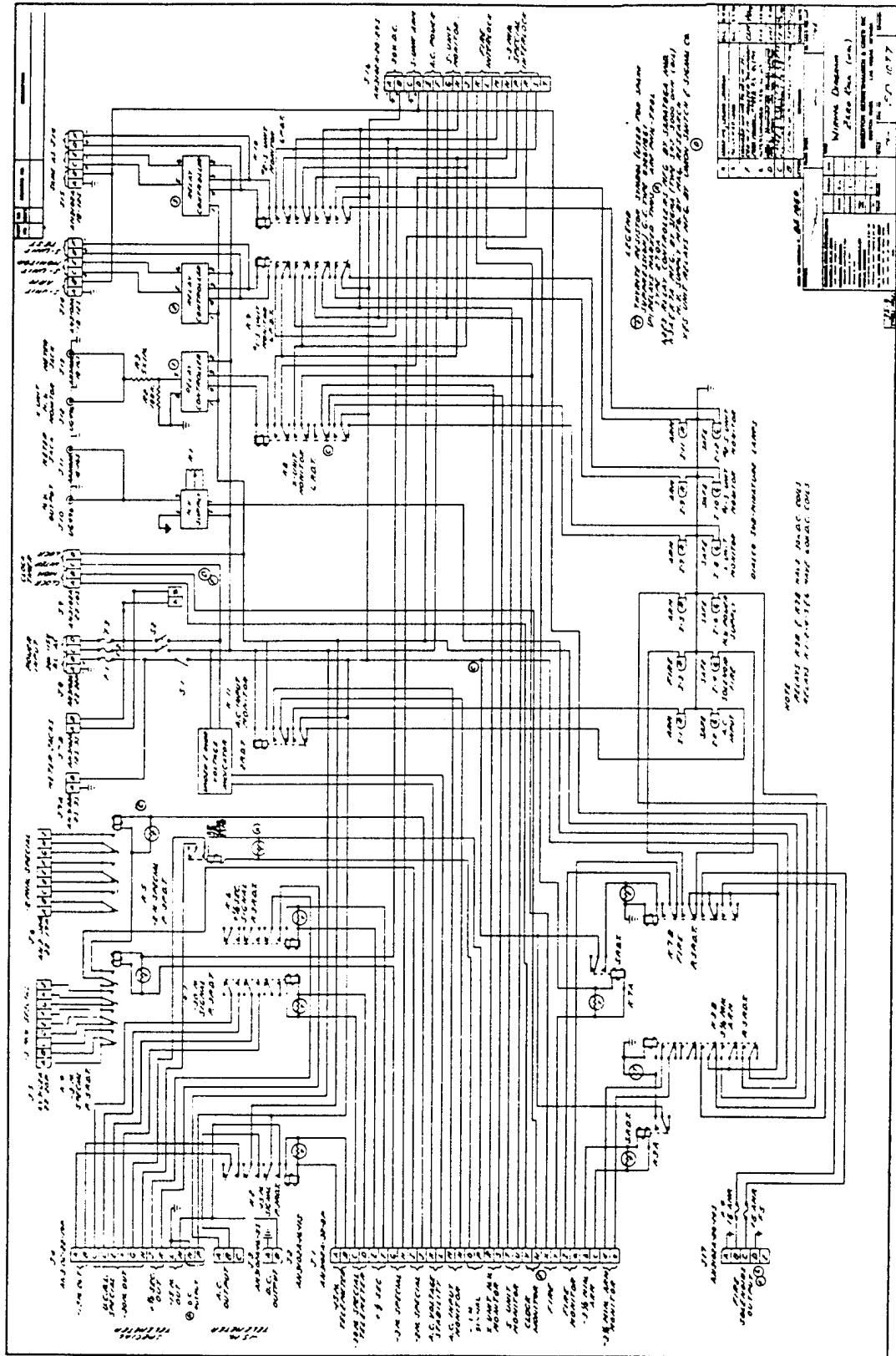

Fig. 2. 8 - Schematic diagram of UCRL zero rack type SA9A

into service. The necessary modifications were made at the test site. These racks comprised the following types:

1 Type BD-1212 rack (modified from spare underwater rack made for Phase I.)

1 rack (no type designation) made from spare parts available

3 Type 3406 racks (Plumbbob)

No zero racks of any kind were available for Titania, the last UCRL shot; however, EG&G personnel retrieved spare parts from a number of other units and constructed an operative unit within three days.

Each zero rack was subjected to a thorough check to ascertain its compatibility with associated zero site equipment.

## Chapter 3

### COMMUNICATIONS

#### 3.1 GENERAL

EG&G operated three communications networks on Hardtack, Phase II. These nets are listed in Table 3.1.

Table 3.1 - COMMUNICATIONS NETWORKS USED ON HARDTACK, PHASE II

Net	Frequency (MC)	User
EG&G Net	152.87	EG&G
Voice-Time Net No. 1	154.57	LASL
Voice-Time Net No. 2	154.89	UCRL

A 30-watt transmitter for each net was located in Station 372 near the CP. Stacked coaxial-type antennas were mounted on the 100-ft. tower above the station. The transmitters were keyed by foot switches at the CP control console, and selection of nets was controlled from the communications panel on the console.

EG&G supplied users with Motorola Type L03G-1 receiving units as requested. EG&G stations used two-way Motorola Type L43G-1 transceivers. A total of 26 fixed stations and approximately 13 vehicles were equipped with receivers or transceivers. Ground-plane antennas were mounted on the fixed stations; the mobile units employed clip-on type whip antennas. An EG&G-net transceiver was installed at each zero site to maintain communications during setup of the device and the instrumentation. The transceiver was removed by the arming party prior to shot time.

#### 3.2 EG&G COMMUNICATIONS NET

This net provided communications among the EG&G stations and mobile units in the field for the performance of AEC support activities. Good communications were maintained throughout the operation. Some difficulty was anticipated in maintaining two-way communications with the most remote EG&G photostation (Station 1204), about 25 miles from the CP; however, very satisfactory line-of-sight transmission was achieved by locating the antenna on a 30-ft. telescoping mast at the highest point near the photostation.

The tunnel shots in Area 12 posed a special communications problem, since the zero locations were anywhere from 300- to 1500-ft. back from the portal of the tunnel.

To meet the requirement for communications at the zero site, a remote handset containing microphone, speaker and keying switch was connected by hard wire to a modified transceiver. The transceiver and antenna were installed outside the tunnel portal and shielded from the weather. A disconnect was provided at the remote handset so that the handset could be removed by the arming party before the shot.

Either voice-time net could be patched into the EG&G net by a switch on the control console; this arrangement eliminated the need for a separate receiver for dry runs at the EG&G stations.

### 3.3 VOICE-TIME NETS

The voice-time nets transmitted the countdown to all users on both dry and live runs. The use of separate nets for LASL and UCRL shots provided the capability of conducting dry runs for two shots simultaneously. EG&G supplied LASL and UCRL with VHF radio receivers for their respective nets.

When necessary, voice-time broadcasts were also transmitted over all other nets, including the Air Operations Center (AOC) and the Reynolds Electrical and Engineering Company (REECO) communications systems. The audio was fed by direct line from the control-console microphones to the above users.

The communications system proved to be very satisfactory. No important equipment failures were reported, and minor difficulties were easily corrected.

## Chapter 4

### WORLD TIME DETERMINATION

Twenty-Six safety and full scale tests, including three underground detonations, were instrumented for world time. The precise time of detonation with respect to world time was determined for those bursts which emitted sufficient light to trigger the world-time system.

The world-time indicator, EG&G World-Time Clock Type TD-3, is a rack-mounted unit consisting of a digital clock and an electronic interval counter on which time can be read to a tenth of a millisecond. Figure 4.1 shows the clock face. At zero time, the counter reading is recorded on film in a Polaroid-back camera which is mounted on the face of the indicator. Fiducial marker units, activated by light from the burst, transmit a pulse to the world-time indicator, stopping the electronic counter and operating the camera shutter. On Phase II the fiducial marker units were located on the roof of the CP-1 building; aiming was accomplished by timing and firing personnel.

To eliminate the possibility of clock drift, the world-time system was periodically synchronized to the WWV audio signal. A detailed description of the system operation is given in Report WT-1686, Operation Hardtack Timing and Firing.

A remote fiducial system was operated on tunnel shots Tamalpais, Logan, and Blanca. UCRL furnished the zero-fiducial signal, which was obtained from a photodiode located near the device. The photodiode, actuated by the appearance of light from the detonation, produced a 1  $\mu$ sec pulse with a rise time of 0.05  $\mu$ sec and an amplitude of 100 v. On dry runs the photodiode was actuated by a flash tube. An EG&G Blue Box, Type A-1, located outside the tunnel, was modified to receive the 50-ohm coaxial cable connected to the photodiode. The pulse triggered the Blue Box, which, in turn, provided a relay closure to the world-time system at the CP. The delay time of this system varied according to the length of the transmission cable for the particular shot.

The detonation times for the thirty-seven shots of Operation Hardtack, Phase II, are enumerated in Table 4.1. Fifteen of these shots triggered the world-time system; times for these shots are quoted to the nearest millisecond. When there was any uncertainty in the operation of the system, appropriate accuracy limits were assigned. For all other shots, including underground, non-nuclear, and low light-level detonations, the time of detonation, based on known delays in the system, is estimated at 150 msec  $\pm$  100 msec after transmission of the "fire" signal.

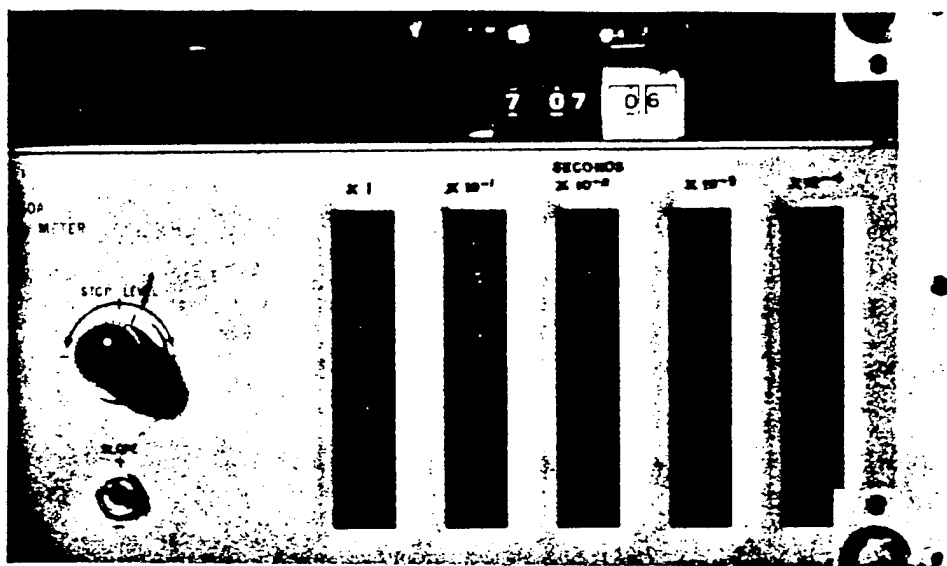

Fig. 4.1 - World time clock type TD-3

Table 4.1 - WORLD TIME SUMMARY

Shot Name	Date	Area	Time (PST)
Otero	Sept. 12	U-3q	1200:00.15 ± 0.1 sec
Bernallilo	Sept. 17	U-3n	1130:00.15 ± 0.1 sec
Eddy	Sept. 19	B-7b	0600:00.15 ± 0.1 sec
Luna	Sept. 21	U-3m	1100:00.15 ± 0.1 sec
Mercury	Sept. 23	U-12	1400:00.15 ± 0.1 sec
Valencia	Sept. 26	U-3r	1200:00.15 ± 0.1 sec
Mars	Sept. 27	U-12	1600:00.15 ± 0.1 sec
Mora	Sept. 29	B-7b	0605:00.077
Hidalgo	Oct. 5	B-7b	0610:00.137 ± 1 msec
Colfax	Oct. 5	U-3k	0815:00.15 ± 0.1 sec
Tamalpais	Oct. 8	U-12	1400:00.131 ± 10 msec
Quay	Oct. 10	T-7c	0630:00.142
Lea	Oct. 13	B-7b	0520:00.136
Neptune	Oct. 14	U-12	1000:00.15 ± 0.1 sec
Hamilton	Oct. 15	T-F1	0800:00.15 ± 0.1 sec
Logan	Oct. 15	U-12	2200:00.140 ± 5 msec
Dona Ana	Oct. 16	B-7b	0620:00.144
Vesta*	Oct. 17	S-9e	1500:00.15 ± 0.1 sec
Rio Arriba	Oct. 18	T-3s	0625:00.120
San Juan	Oct. 20	U-3p	0630:00.15 ± 0.1 sec
Socorro	Oct. 22	B-7b	0530:00.15 ± 0.1 sec
Wrangell	Oct. 22	B-Fa	0850:00.115
Oberon	Oct. 22	T-8a	1230:00.15 ± 0.1 sec
Rushmore	Oct. 22	B-9a	1540:00.129
Catron	Oct. 24	T-3t	0700:00.164
Juno	Oct. 24	S-9f	0801:00.15 ± 0.1 sec
Ceres	Oct. 25	T-8b	2000:00.15 ± 0.1 sec
DeBaca	Oct. 26	B-7b	0800:00.141
Sanford	Oct. 26	B-Fa	0220:00.132
Chaves	Oct. 27	T-3u	0630:00.15 ± 0.1 sec
Evans**	Oct. 28	U	1600:00.15 ± 0.1 sec
Mazama	Oct. 29	T-9d	0320:00.15 ± 0.1 sec
Humboldt	Oct. 29	T-3u	0645:00.107
Santa Fe	Oct. 29	B-7b	1900:00.149
Ganymede	Oct. 30	S-9g	0300:00.15 ± 0.1 sec
Blanca***	Oct. 30	U	0700:00.15 ± 0.1 sec
Titania	Oct. 30	T-8e	1234:00.15 ± 0.1 sec

\* No attempt to measure time

\*\* Blue Box WT Trigger

\*\*\* Tunnel System set up but failed to trigger

## Chapter 5

### BHANGMETERS

Two Mark V Bhangmeters for determining yield on the basis of time-to-light minimum were housed in a rack near the CP console. Photoheads for the Bhangmeters were mounted on the roof of the CP-1 building; aiming was accomplished by timing and firing personnel.

The Bhangmeters were provided with 6 sweep-speed settings ranging from 5 msec to 160 msec. Prior to the shot, the sweep speed was chosen on the basis of the predicted size of the detonation.

Bhangmeters were operated on twenty-one shots, including both safety and full scale tests. On seven of these shots, the light from the burst was insufficient to trigger the Bhangmeters, and no records were obtained. Yields based on time-to-light minimum as recorded by the Bhangmeters are listed in Table 5.1 for the remaining shots.

Table 5.1 - BHANGMETER RESULTS

Shot	No. Of Records Obtained	Average Time-to-Min. ( usec )	Bhangmeter Yield (KT)
Eddy*	--	--	--
Mora	2	5.25	2.0 KT ± 20%
Hidalgo	1	1.25	0.090 KT ± 20%
Quay	2	1.5	0.135 KT ± 50%
Lea	1	4.25	1.2 KT ± 20%
Hamilton*	0	--	--
Dona Ana	2	0.750; 0.875	0.035 KT ± 50%
Rio Arriba	2	1.375, 1.50	0.120 KT ± 30%
Socorro	2	9.0; off scale @ 10 msec	6.0 KT ± 20%
Wrangell	2	1.5	0.130 KT ± 20%
Rushmore	2	2.0	0.250 KT ± 30%
Oberon *	0	--	--
Catron	1	0.75	0.020 KT ± 30%
Ceres*	0	--	--
Sanford	2	7.7	5.0 KT ± 20%
De Baca	2	6.0	2.5 KT ± 20%
Chaves*	0	--	--
Mazama*	0	--	--
Santa Fe	2	3.75	1.0 KT ± 10%
Ganymede*	0	--	--
Titania*	0	--	--
Humboldt	1	0.38	< 0.010 KT

\* Insufficient Light Intensity

## DISTRIBUTION

### Military Distribution Category 2

#### ARMY ACTIVITIES

- 1 Deputy Chief of Staff for Military Operations, D/A, Washington 25, D.C. ATTN: Dir. of SW&R
- 2 Chief of Research and Development, D/A, Washington 25, D.C. ATTN: Atomic Div.
- 3 Assistant Chief of Staff, Intelligence, D/A, Washington 25, D.C.
- 4 The Quartermaster General, D/A, Washington 25, D.C. ATTN: Research and Dev.
- 5-6 Chief Chemical Officer, D/A, Washington 25, D.C.
- 7 Chief of Engineers, D/A, Washington 25, D.C. ATTN: ENORGB
- 8 Chief of Engineers, D/A, Washington 25, D.C. ATTN: ENOTB
- 9 Chief Signal Officer, D/A, Comb. Dev. and Ops. Div., Washington 25, D.C. ATTN: SIGCO-4
- 10 Chief of Transportation, D/A, Office of Planning and Int., Washington 25, D.C.
- 11 The Surgeon General, D/A, Washington 25, D.C. ATTN: MEKRE
- 12-13 Commanding General, U.S. Continental Army Command, Ft. Monroe, Va.
- 14 Director of Special Weapons Development Office, Headquarters CONARC, Ft. Bliss, Tex. ATTN: Capt. Chester I. Peterson
- 15 President, U.S. Army Artillery Board, U.S. Continental Army Command, Ft. Sill, Okla.
- 16 President, U.S. Army Air Defense Board, U.S. Continental Army Command, Ft. Bliss, Tex.
- 17 Commanding General, First United States Army, Governor's Island, New York 4, N.Y.
- 18 Commanding General, Second U.S. Army, Ft. George G. Meade, Md.
- 19 Commanding General, Third United States Army, Ft. McPherson, Ga. ATTN: ACoFS G-3
- 20 Commanding General, Fourth United States Army, Ft. Sam Houston, Tex. ATTN: G-3 Section
- 21 Commanding General, Fifth United States Army, 1660 E. Hyde Park Blvd., Chicago 15, Ill.
- 22 Commanding General, Sixth United States Army, Presidio of San Francisco, San Francisco, Calif. ATTN: AMOCT-4
- 23 Commanding General, Military District of Washington, USA, Room 1543, Bldg. T-7, Gravelly Point, Va.
- 24 Commandant, U.S. Army Command & General Staff College, Ft. Leavenworth, Kansas. ATTN: ARCHIVES
- 25 Commandant, U.S. Army Air Defense School, Ft. Bliss, Tex. ATTN: Dept. of Tactics and Combined Arms
- 26 Commandant, U.S. Army Armored School, Ft. Knox, Ky.
- 27 Commandant, U.S. Army Artillery and Missile School, Ft. Sill, Okla. ATTN: Combat Development Department
- 28 Commandant, U.S. Army Infantry School, Ft. Benning, Ga. ATTN: C.D.S.
- 29 The Superintendent, U.S. Military Academy, West Point, N.Y. ATTN: Prof. of Ordnance
- 30 Commandant, The Quartermaster School, U.S. Army, Ft. Lee, Va. ATTN: Chief, QM Library
- 31 Commandant, U.S. Army Ordnance School, Aberdeen Proving Ground, Md.
- 32 Commandant, U.S. Army Ordnance and Guided Missile School, Redstone Arsenal, Ala.
- 33 Commanding General, Chemical Corps Training Comd., Ft. McClellan, Ala.
- 34 Commandant, USA Signal School, Ft. Monmouth, N.J.
- 35 Commandant, USA Transport School, Ft. Eustis, Va. ATTN: Security and Info. Off.
- 36 Commanding General, The Engineer Center, Ft. Belvoir, Va. ATTN: Asst. Cmdt, Engr. School
- 37 Commanding General, Army Medical Service School, Brooks Army Medical Center, Ft. Sam Houston, Tex.
- 38 Director, Armed Forces Institute of Pathology, Walter Reed Army Med. Center, 625 16th St., NW, Washington 25, D.C.

- 39 Commanding Officer, Army Medical Research Lab., Ft. Knox, Ky.
- 40 Commandant, Walter Reed Army Inst. of Res., Walter Reed Army Medical Center, Washington 25, D.C.
- 41 Commanding General, QM R&D Comd., QM R&D Cntr., Watck, Mass. ATTN: CER Liaison Officer
- 42 Commanding General, Qm. Research and Engr. Comd., USA, Watck, Mass.
- 43 Commanding General, U.S. Army Chemical Corps, Research and Development Comd., Washington 25, D.C.
- 44 Commanding Officer, Chemical Warfare Lab., Army Chemical Center, Md. ATTN: Tech. Library
- 45 Commanding General, Engineer Research and Dev. Lab., Ft. Belvoir, Va. ATTN: Chief, Tech. Support Branch
- 46 Director, Waterways Experiment Station, P.O. Box 631, Vicksburg, Miss. ATTN: Library
- 47 Commanding Officer, USA Signal R&D Laboratory, Ft. Monmouth, N.J.
- 48 Commanding General, U.S. Army Electronic Proving Ground, Ft. Huachuca, Ariz. ATTN: Tech. Library
- 49 Commanding Officer, USA, Signal R&D Laboratory, Ft. Monmouth, N.J. ATTN: Tech. Doc. Ctr., Evans Area
- 50 Commanding Officer, USA Transportation R&E Comd., Ft. Eustis, Va. ATTN: Chief, Tech. Svcs. Div.
- 51 Director, Operations Research Office, Johns Hopkins University, 6935 Arlington Rd., Bethesda 14, Md.

#### NAVY ACTIVITIES

- 52 Chief of Naval Operations, D/N, Washington 25, D.C. ATTN: OP-36
- 53 Chief of Naval Operations, D/N, Washington 25, D.C. ATTN: OP-91
- 54 Chief of Naval Personnel, D/N, Washington 25, D.C.
- 55-56 Chief of Naval Research, D/N, Washington 25, D.C. ATTN: Code 811
- 57 Chief, Bureau of Aeronautics, D/N, Washington 25, D.C.
- 58 Chief, Bureau of Medicine and Surgery, D/N, Washington 25, D.C. ATTN: Special Wpns. Def. Div.
- 59 Chief, Bureau of Ordnance, D/N, Washington 25, D.C.
- 60 Chief, Bureau of Ships, D/N, Washington 25, D.C. ATTN: Code 423
- 61 Chief, Bureau of Supplies and Accounts, D/N, Washington 25, D.C.
- 62 Chief, Bureau of Yards and Docks, D/N, Washington 25, D.C. ATTN: D-440
- 63 Director, U.S. Naval Research Laboratory, Washington 25, D.C. ATTN: Mrs. Katherine E. Cass
- 64 Commander, U.S. Naval Ordnance Laboratory, White Oak, Silver Spring 19, Md.
- 65 Director, Material Lab. (Code 900), New York Naval Shipyard, Brooklyn 1, N.Y.
- 66 Commanding Officer, U.S. Naval Radiological Defense Laboratory, San Francisco, Calif. ATTN: Tech. Info. Div.
- 67 Officer-in-Charge, U.S. Naval Civil Engineering R&E Lab., U.S. Naval Construction En. Center, Fort Huachuca, Calif. ATTN: Code 753
- 68 President, U.S. Naval War College, Newport, Rhode Island
- 69 Commanding Officer, U.S. Naval Medical Research Institute, National Naval Medical Center, Bethesda, Md.
- 70 Commanding Officer and Director, David W. Taylor Model Basin, Washington 7, D.C. ATTN: Library
- 71 Commander-in-Chief, U.S. Atlantic Fleet, U.S. Naval Base, Norfolk 11, Va.
- 72 Commandant, U.S. Marine Corps, Washington 25, D.C. ATTN: Code AO3H
- 73 Commanding General, Fleet Marine Force, Atlantic, Norfolk, Va.

**CONFIDENTIAL**

74	Director, U.S.M.C. Development Center, U.S.M.C. Schools, Quantico, Va.	99	Commandant, School of Aviation Medicine, USAF, Randolph AFB, Tex. ATTN: Research Secretariat
75	Director, U.S.M.C. Educational Center, U.S.M.C. Schools, Quantico, Va.	100-102	Commander, Wright Air Development Center, Wright-Patterson AFB, Dayton, Ohio. ATTN: WCOSI
76	Commandant, U.S. Coast Guard, 1300 E. St., NW, Washington 25, D.C. ATTN: (OIN)	103-104	Director, USAF Project RAND, VIA: USAF Liaison Office, The RAND Corp., 1700 Main St., Santa Monica, Calif.
77	Commander-in-Chief, U.S. Pacific Fleet, Fleet Post Office, San Francisco, Calif.	105	Commander, 3535th Navigator Wing, Mather AFB, Calif.
78	Commanding General, Fleet Marine Force, Pacific, Fleet Post Office, San Francisco, Calif.		
	<b>AIR FORCE ACTIVITIES</b>		<b>OTHER DEPARTMENT OF DEFENSE ACTIVITIES</b>
79	Assistant for Atomic Energy, HQ, USAF, Washington 25, D.C. ATTN: DCS/O	106	Director of Defense Research and Engineering, Washington 25, D.C. ATTN: Tech. Library
80	Deputy Chief of Staff, Operations HQ, USAF, Washington 25, D.C. ATTN: Operations Analysis	107	Director, Weapons Systems Evaluation Group, Room 1E880, The Pentagon, Washington 25, D.C.
81-82	Assistant Chief of Staff, Intelligence, HQ, USAF, Washington 25, D.C. ATTN: AFCIN-IB2	108-115	Chief, Armed Forces Special Weapons Project, Washington 25, D.C.
83	Deputy Chief of Staff, Plans and Programs, HQ, USAF, Washington 25, D.C. ATTN: War Plans Division	116	Commander, Field Command, AFSWP, Sandia Base, Albuquerque, N. Mex.
84	Director of Research and Development, DCS/D, HQ, USAF, Washington 25, D.C. ATTN: Guidance and Weapons Div.	117	Commander, Field Command, AFSWP, Sandia Base, Albuquerque, N. Mex. ATTN: FCTG
85	The Surgeon General, HQ, USAF, Washington 25, D.C. ATTN: Bio.-Def. Pre. Med. Division	118-122	Commander, Field Command, AFSWP, Sandia Base, Albuquerque, N. Mex. ATTN: FCWT
86	Commander-in-Chief, Strategic Air Command, Offutt AFB, Neb. ATTN: OAWS	123	Commander, JTF-7, Arlington Hall Station, Arlington 12, Va.
87	Commander, Tactical Air Command, Langley AFB, Va. ATTN: Doc. Security Branch	124	U.S. Documents Officer, Office of the United States National Military Representative - SSHAPE, APO 55, New York, N.Y.
88	Commander, Air Defense Command, Ent AFB, Colorado. ATTN: Atomic Energy Div., ADLAN-A		<b>ATOMIC ENERGY COMMISSION ACTIVITIES</b>
89	Commander, Eq. Air Research and Development Command, Andrews AFB, Washington 25, D.C. ATTN: EDMA	125-127	U.S. Atomic Energy Commission, Technical Reports Library, Washington 25, D.C. ATTN: Mrs. J. M. O'Leary (For IDA)
90	Commander, Western Development Division (ARDC) P.O. Box 262, Inglewood, Calif. ATTN: WDHIT, Mr. E. G. Weitz	128-129	Los Alamos Scientific Laboratory, Report Library, P.O. Box 1663, Los Alamos, N. Mex. ATTN: Helen Redman
91-92	Commander, AF Cambridge Research Center, L. G. Hanscom Field, Bedford, Mass. ATTN: CRQST-2	130-134	Sandia Corporation, Classified Document Division, Sandia Base, Albuquerque, N. Mex. ATTN: E. J. Smyth, Jr.
93-95	Commander, Air Force Special Weapons Center, Kirtland AFB, Albuquerque, N. Mex. ATTN: Tech. Info. & Intel. Div.	135-137	University of California Radiation Laboratory, P.O. Box 808, Livermore, Calif. ATTN: Clovis G. Craig
96-97	Director, Air University Library, Maxwell AFB, Ala.	138	Weapon Data Section, Technical Information Service Extension, Oak Ridge, Tenn.
98	Commander, Lovry AFB, Denver, Colorado. ATTN: Dept. of Sp. Wpns. Tng.	139-175	Technical Information Service Extension, Oak Ridge, Tenn. (Surplus)