

ARMY RESEARCH LABORATORY



JA2 Electrothermal-Chemical (ETC) Firings With Modified 400-kJ Pulser

M. Del Guercio
I. Stobie
W. Oberle

ARL-TN-66

May 1996

19960626 167

APPROVED FOR PUBLIC RELEASE; DISTRIBUTION IS UNLIMITED.

DISCLAIMER NOTICE

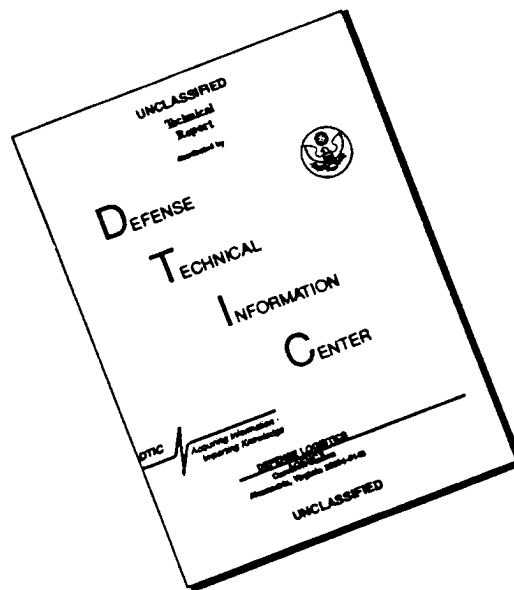

THIS DOCUMENT IS BEST QUALITY AVAILABLE. THE COPY FURNISHED TO DTIC CONTAINED A SIGNIFICANT NUMBER OF PAGES WHICH DO NOT REPRODUCE LEGIBLY.

NOTICES

Destroy this report when it is no longer needed. DO NOT return it to the originator.

Additional copies of this report may be obtained from the National Technical Information Service, U.S. Department of Commerce, 5285 Port Royal Road, Springfield, VA 22161.

The findings of this report are not to be construed as an official Department of the Army position, unless so designated by other authorized documents.

The use of trade names or manufacturers' names in this report does not constitute indorsement of any commercial product.

REPORT DOCUMENTATION PAGE			Form Approved OMB No. 0704-0188	
Public reporting burden for this collection of information is estimated to average 1 hour per response, including the time for reviewing instructions, searching existing data sources, gathering and maintaining the data needed, and completing and reviewing the collection of information. Send comments regarding this burden estimate or any other aspect of this collection of information, including suggestions for reducing this burden, to Washington Headquarters Services, Directorate for Information Operations and Reports, 1215 Jefferson Davis Highway, Suite 1204, Arlington, VA 22202-4302, and to the Office of Management and Budget, Paperwork Reduction Project(0704-0188), Washington, DC 20503.				
1. AGENCY USE ONLY (Leave blank)		2. REPORT DATE May 1996	3. REPORT TYPE AND DATES COVERED Final, Mar 94-Feb 95	
4. TITLE AND SUBTITLE JA2 Electrothermal-Chemical (ETC) Firings With Modified 400-kJ Pulser			5. FUNDING NUMBERS PR: 1L162618AH80	
6. AUTHOR(S) M. Del Guercio, I. Stobie, and W. Oberle				
7. PERFORMING ORGANIZATION NAME(S) AND ADDRESS(ES) U.S. Army Research Laboratory ATTN: AMSRL-WT-PA Aberdeen Proving Ground, MD 21005-5066			8. PERFORMING ORGANIZATION REPORT NUMBER ARL-TN-66	
9. SPONSORING/MONITORING AGENCY NAME(S) AND ADDRESS(ES)			10. SPONSORING/MONITORING AGENCY REPORT NUMBER	
11. SUPPLEMENTARY NOTES				
12a. DISTRIBUTION/AVAILABILITY STATEMENT Approved for public release; distribution is unlimited.			12b. DISTRIBUTION CODE	
13. ABSTRACT (Maximum 200 words) A 300-kJ pulse-forming network (PFN) with a pulse width of 1.2 ms was upgraded to 400-kJ maximum energy output and 2.4-ms pulse width by increasing the number of its six capacitors and by replacing its six inductors by larger ones. As the new pulser was desired to also provide the shorter original pulse of 1.2 ms, tests were performed in which only four of its eight new banks were left connected. A match of the new pulser output parameters was found when the new PFN charging was varied from 3 kV to 4 kV to match the same output energy levels as with the previous 300-kJ pulser. Also, the modified pulser showed that for a 1.2-ms pulse width and PFN charging voltages of 4 kV and 5 kV, there was a noticeable increase on the propellant (JA2 disks) burn rate when compared with previous pulser data.				
14. SUBJECT TERMS pulser, pulse-forming network (PFN), burn rate			15. NUMBER OF PAGES 40	
			16. PRICE CODE	
17. SECURITY CLASSIFICATION OF REPORT UNCLASSIFIED	18. SECURITY CLASSIFICATION OF THIS PAGE UNCLASSIFIED	19. SECURITY CLASSIFICATION OF ABSTRACT UNCLASSIFIED	20. LIMITATION OF ABSTRACT UL	

INTENTIONALLY LEFT BLANK.

TABLE OF CONTENTS

	<u>Page</u>
LIST OF FIGURES	v
1. BACKGROUND	1
2. TEST OBJECTIVES	3
3. SUMMARY OF RESULTS	4
4. CONCLUSION	7
APPENDIX A: ETC 120-cm ³ CLOSED CHAMBER FIRING MATRIX	9
APPENDIX B: FIRING INFORMATION DATA SHEETS	13
APPENDIX C: EXPERIMENTAL PRESSURE AND PULSER ENERGY OUTPUT	17
APPENDIX D: BURN RATES	25
DISTRIBUTION LIST	39

INTENTIONALLY LEFT BLANK.

LIST OF FIGURES

<u>Figure</u>	<u>Page</u>
1. 300-kJ pulser	1
2. 400-kJ pulser	2
3a. 1.2-ms pulser simulation	3
3b. 2.4-ms pulser simulation	3
4a. Load current vs. time	5
4b. Energy vs. time	5
4c. Power vs. time	5
5a. Table 1 burn rates	6
5b. Table 2 burn rates	6
A-1. Pulser schematic and ETC closed chamber setup	11
C-1. Ident 03154S1 (ETC firing), pressure vs. time	19
C-2. Ident 03154S1 (ETC firing), energy vs. time	19
C-3. Ident 03154S2 (ETC firing), pressure vs. time	20
C-4. Ident 03154S2 (ETC firing), energy vs. time	20
C-5. Ident 03154S3 (ETC firing), pressure vs. time	21
C-6. Ident 03154S3 (ETC firing), energy vs. time	21
C-7. Ident 01315S3 (ETC firing), pressure vs. time	22
C-8. Ident 01315S3 (ETC firing), energy vs. time	23
C-9. Ident 02095S5 (ETC firing), energy vs. time	22
C-10. Ident 02095S5 (ETC firing), pressure vs. time	23
C-11. Ident 02105S7 (ETC firing), pressure vs. time	24

<u>Figure</u>	<u>Page</u>
C-12. Ident 02105S7 (ETC firing), energy vs. time	24
D-1. Burn rate ident 03154S1	27
D-2. Burn rate ident 03154S2	29
D-3. Burn rate ident 03184S3	31
D-4. Burn rate ident 01315S3	33
D-5. Burn rate ident 02095S5	35
D-6. Burn rate ident 02105S7	37

1. BACKGROUND

Electrothermal-chemical (ETC) closed chamber firings were conducted in March 1994 with the purpose of characterizing JA2 propellant (disc configuration) by plasma augmentation. These were short-pulse (1.2 ms) and low-energy (15 kJ) firings utilizing a pulse-forming network (PFN) with a total energy capability of 300 kJ. Specifically, this pulser consisted of a total of six 830- μ F capacitors and six 10- μ H inductors with a fixed pulse length of 1.2 ms (Figure 1). The PFN schematic and the 120-cm³ closed chamber vessel setup are in Appendix A. Appendix B contains firing information data sheets for these firings.

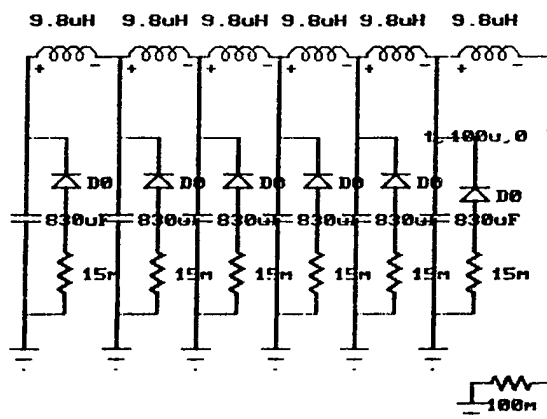

Figure 1. 300- kJ pulser.

To better investigate the impact of an electrically generated plasma on propellant combustion, it was decided to increase the pulse duration. Thus the PFN was upgraded to a total energy capability of 400 kJ by increasing the number of capacitors and inductors to eight each, increasing its pulse length to 2.4 ms. The two capacitors added were of the same values as the existing capacitors. The inductors, however, were replaced by eight new ones of 30 μ H each (Figure 2). It was also desirable for the new pulser to have the flexibility to produce a comparable 1.2-ms pulse length.

New test firings were conducted in January and February 1995 with the upgraded pulser. The objectives of these tests were to determine: a) the right number of capacitors and larger inductors to leave connected to the circuit to obtain a comparable 1.2-ms pulse profile to the previous PFN and b) the charging voltage on the modified PFN to match the energy of the previous firings.

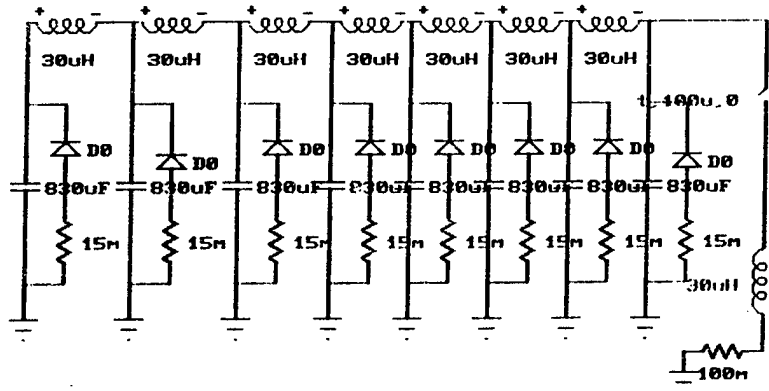

Figure 2. 400-kJ pulser.

Microcap III¹ simulations were used to determine that a combination of four capacitors and four new inductors with a charging voltage of 4 kV (Table 1) gave the best 1.2-ms pulse approximation (1.3 ms). The charging voltage was then increased from the 3 kV used with the old configuration of six capacitors and six inductors, to 4 kV on the modified PFN. This left four capacitors and four of the new 30- μ H inductors connected to the bus. The current, voltage, and energy of both previous and new firings are shown in Figures 3a and 3b, respectively.

Table 1. Modified Pulser

Shot ID	Propellant Type	Propellant Weight (g)	Charging Voltage (kV)	Energy Output (kJ)
01245S1	JA2 Disks	27.15	3.7	8.10
01305S2	JA2 Disks	27.23	3.8	7.00
01315S3	JA2 Disks	27.11	5.0	33.0
02015S4	JA2 Disks	27.26	4.4	8.00
02095S5	JA2 Disks	27.23	4.0	18.0
02105S7	JA2 Disks	27.13	4.0	23.0

¹Microcap III A Circuit Analysis Software, Spectrum Software, Sunnyvale, CA.

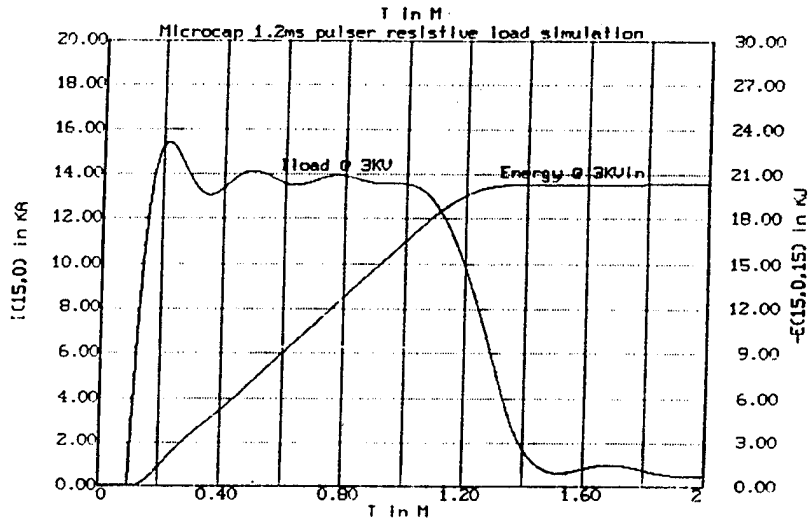

Figure 3a. 1.2-ms pulser simulation.

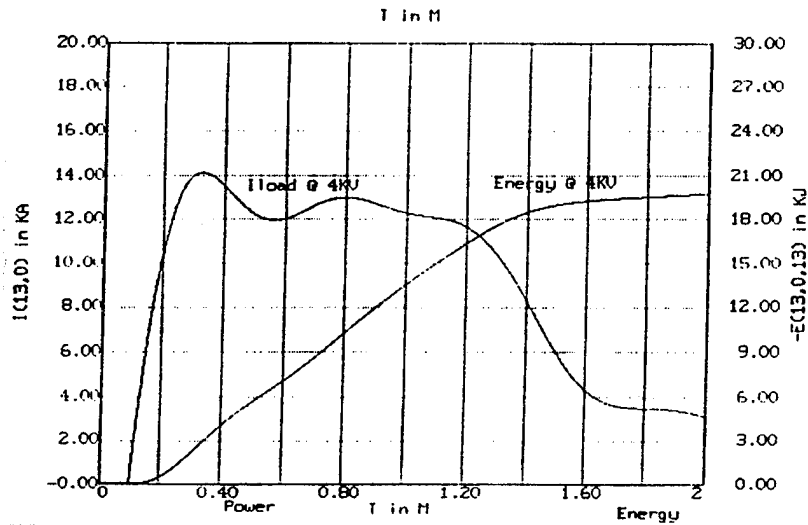

Figure 3b. 2.4-ms pulser simulation.

2. TEST OBJECTIVES

The purpose of the firings was to reproduce the results of the previous tests with the lower energy pulser (Figure 1). Six firings were conducted with variation in the PFN charging voltage from 3 kV to 5 kV (Table 1). Firings with the modified pulser (Table 1) shows that the PFN charging voltage was increased to match the output energy of the previous firings of Table 2. Discrepancies in the data resulted

Table 2. 1.2-ms Pulser

Shot ID	Propellant Type	Propellant Weight (g)	Charging Voltage (kV)	Energy Output (kJ)
03154S1	JA2 Disks	27.50	3	16.0
03154S2	JA2 Disks	27.69	3	16.0
03184S3	JA2 Disks	34.50	3	16.0

from unexpected shorts or large decreases in efficiency. The test (ident 02095S5) that matched the previous results of March 1994 (ident 03154S2) had a charging voltage of 4 kV and an energy of approximately 18 kJ. Load current profile and energy and power outputs of ident 03154S2 are shown in comparison to load current and energy and power outputs of ident 02095S5 in Figures 4a-c.

3. SUMMARY OF RESULTS

Calculated burn rates (BRLCB² code) for Tables 1 and 2 firings are shown in Appendix D. Pressure output and electrical energy for each firing are shown in Appendix C. Figure 5a shows a comparison of the burn rates of Table 2 firings with the 1.2-ms pulser. Above 100 MPa, these burn rates are in good agreement; however, firings 03154S2, 03184S3, and 03154S1 show no enhancement on the burn rate during or after the input of electrical energy.

Figure 5b shows a comparison of the burn rates of Table 1 firings done with the upgraded pulser. Table 1 ident 01315S3, 02105S7, and 02095S5 (Figure 5b) show an increase on their burn rates. The electrical energy input ends at about 1.5 ms, which is the decay point of the input current curve to the ETC fixture, and according to the BRLCB output data file, that point corresponds to 70 MPa.

From 40 MPa to 220 MPa, ident 01315S3, 02105S7, and 02095S5 show a burn rate percent difference respect to the 12103S2 ident base line of 80%, 44%, and 30%, respectively. From 70 MPa to 220 MPa, the percent differences in the same order are 56%, 20%, and 35%.

²Oberle, W., and D. E. Kooker. "BRLCB: A Closed-Chamber Data Analysis Program." ARL-TR-36, U.S. Army Research Laboratory, Aberdeen Proving Ground, MD, January 1993.

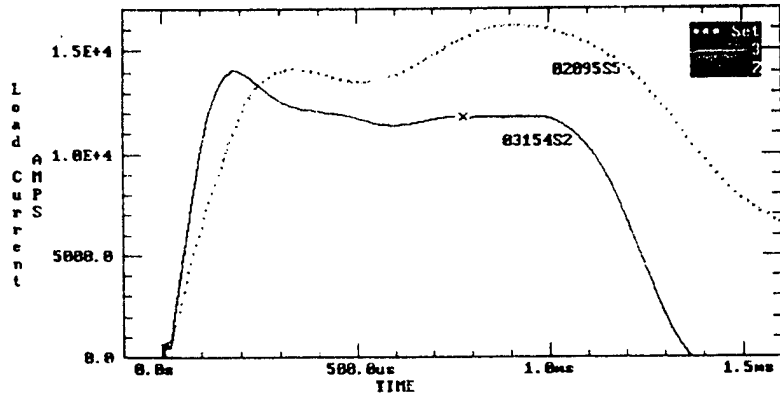

Figure 4a. Load current vs. time.

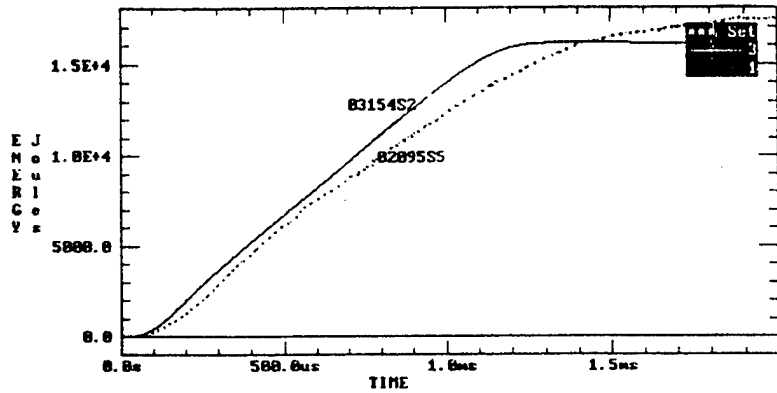

Figure 4b. Energy vs. time.

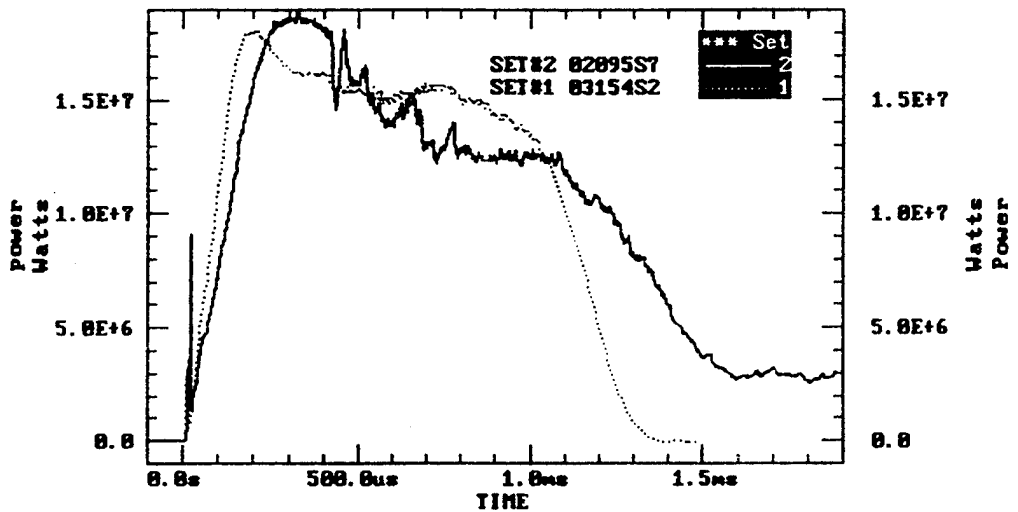

Figure 4c. Power vs. time.

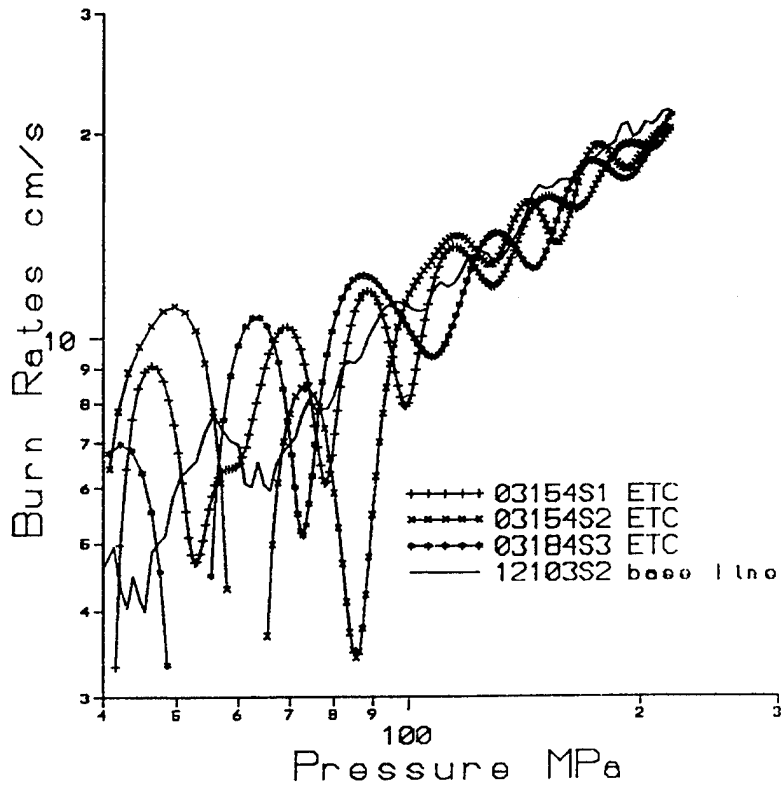

Figure 5a. Table 2 burn rates.

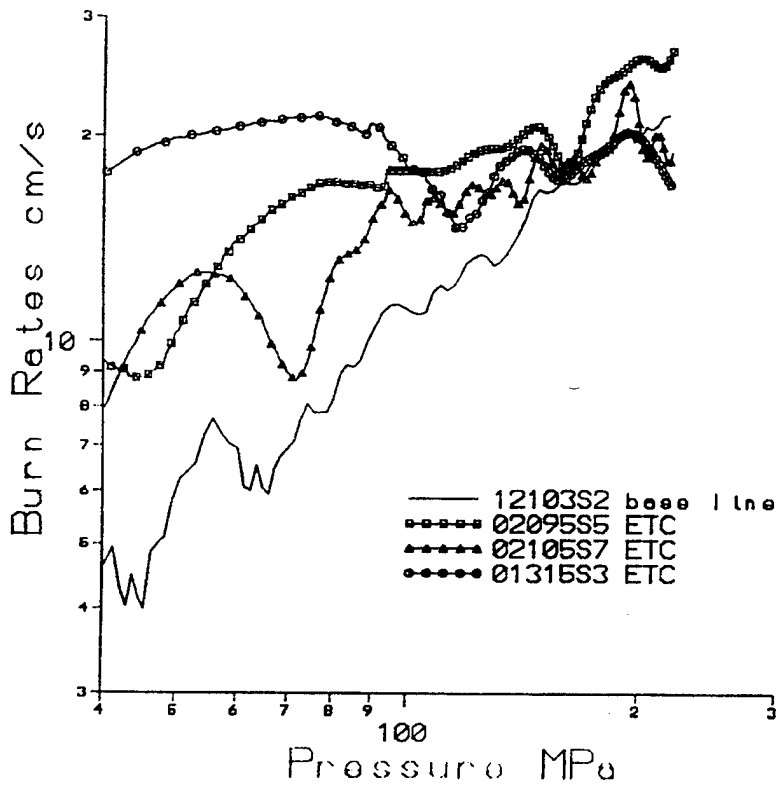

Figure 5b. Table 1 burn rates.

4. CONCLUSION

The increase in energy on the output pulse of the modified PFN due to the larger inductors contributed to the increase in energy (Appendix C, Figures C-7, C-10, and C-12) for idents 02095S5, 01315S3, and 02105S7 from 18 kJ to 33 kJ and 23 kJ, respectively, compared to the 16 kJ firings of Table 2. This increase in energy is significantly reflected on their burn rates (Figure 5b).

INTENTIONALLY LEFT BLANK.

APPENDIX A:
ETC 120-cm³ CLOSED CHAMBER FIRING MATRIX

INTENTIONALLY LEFT BLANK.

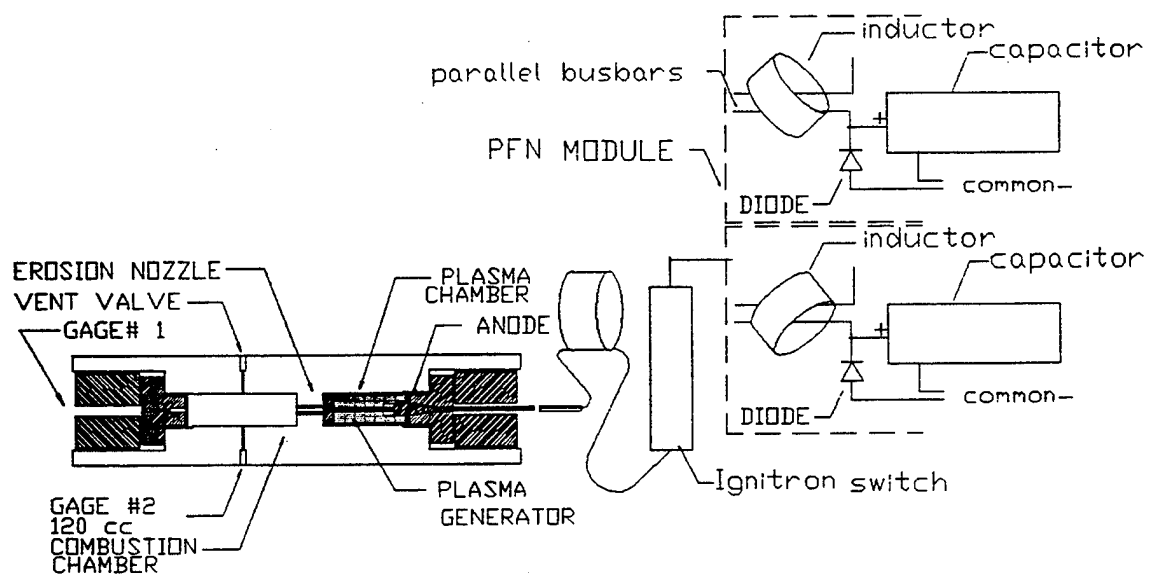

Figure A-1. Pulser schematic and ETC closed chamber setup.

Table A-1. ETC Closed Chamber Firing Matrix

ID No	Loading Density (g/cm ³)	Electrical Energy (kJ)	EE Density (kJ/g)	Charging Voltage (kV)
03154S1	0.21	16	0.58	3
03154S2	0.23	16	0.58	3
03184S3	0.29	16	0.46	3
01245S1	0.23	8	0.29	3.7
01305S2	0.23	7	0.26	3.8
01315S3	0.23	33	1.22	5
02015S4	0.23	8	0.29	4.4
02095S5	0.23	18	0.66	4
02105S7	0.23	23	0.85	4

APPENDIX B:
FIRING INFORMATION DATA SHEETS

INTENTIONALLY LEFT BLANK.

ETCTEML1 INFORMATION SHEET FOR ETC CLOSED CHAMBER FIRING
DATE:03/15/94 SERIES RUN#:1 PROJECT: 129.0 CLOSED CHAMBER
PROPELLANT TYPE:JA2;7perf;LOT #:RAD-PE-792-71 SAMPLE TREATMENT:70F
SAMPLE WEIGHT:27.52g GRAIN DIMENSION:0.6"L, 0.3"D; 0.03 WEB
CHAMBERVOL:129.4cc CALCMAX PRESSURE: 300MPa WINDOW: 2ms

PFNPULSE LENGTH:1.2ms PFN SCHEMATIC#:6caps@830uF ea.&6ind@ 10uHea
PFN Vin DC:3.0kV; EXPECTED ENERGY:16kJ@ 70%efficy;WINDOW :2ms
PEARSON'S CAL K:2630;
vessel's ROGOVSKI#1CAL K:NA ;pfn's ROGOVSKI#2CAL K:82.45E+06

MUZZLE GAGE#1 SN(P1): C47189 SIDE GAGE#2 SN(P2): C42442
gage#1:1rstdegfit coeff:5.76E-02;gage#2:1rstdegfit coeff:6.0E-02

CALIBRATION

*****SCOPE A*****
CAL (DC)VOLTAGE IN :NA
DISK ID: ETC#1
TRACKID: NA
*****SCOPE B*****
CAL (DC)VOLTAGE IN:8.0 V
DISK D: 120cc#2
TRACK ID:5

CAL#1(gage#1)/CHAN 1A: NA
VCAL VOLTAGE OUT:
CAL#2(gage#2)/CHAN 1B:NA
CAL VOLTAGE OUT:
CAL#1(gage#1)/CHAN 1A:8.0 V
CAL VOLTAGE OUT:
CAL#2(gage#2)/CHAN 2A:8.0 V
CAL VOLTAGE OUT:

FIRING

***** SCOPE A*****
DISK ID:ETC#1
TRACK ID:10
SENSITIVITY: MIN
*****SCOPE B*****
DISK ID:120cc#2
TRACK ID:6
SENSITIVITY:MIN

CHANNEL	WINDOW	S.RATE	CHANNEL	WINDOW	S.RATE
1A: P1	50ms	20usxpnt	1A: P1	NA	
1B: P2	50ms	20usxpnt	2A: P2	NA	
2A:di/dt	4ms	.5usxpnt	2A:	NA	
2B: V	4ms	.5usxpnt	1B: ROGOVVKY#2		
ROGOVSKY#1 (m.A/V.s)			ROGOVSKY#2 (m.A/V.s)		

PRESSURE MAX(MPa)
SCOPE ID:B
GAGE ID:#1
PRESSURE MAX(MPa):273
SCOPE ID:B
GAGE ID:#2

ETCTEML1 INFORMATION SHEET FOR ETC CLOSED CHAMBER FIRING
DATE:03/15/94 SERIES RUN#:2 PROJECT: 129.0 CLOSED CHAMBER
PROPELLANT TYPE:JA2;7perf;LOT #:RAD-PE-792-71 SAMPLE TREATMENT:70F
SAMPLE WEIGHT:27.692g GRAIN DIMENSION:0.6"L, 0.3"D; 0.03 WEB
CHAMBERVOL:129.4cc CALCMAX PRESSURE: 300MPa WINDOW: 20ms

PFNPULSE LENGTH:1.2ms PFN SCHEMATIC#:4caps@830uF ea.&4ind@ 30uHea
PFN Vin DC:3.0kV; EXPECTED ENERGY:16kJ@ 70%efficy;WINDOW :2ms
PEARSON'S CAL K:2630;
vessel's ROGOVSKI#1CAL K:NA ;pfn's ROGOVSKI#2CAL K:82.45E+06

MUZZLE GAGE#1 SN(P1): C47189 SIDE GAGE#2 SN(P2): C42442
gage#1:1rstdegfit coeff:5.76E-02;gage#2:1rstdegfit coeff:6.0E-02

CALIBRATION

*****SCOPE A*****
CAL (DC)VOLTAGE IN :NA
DISK ID: ETC#1
TRACKID: NA
*****SCOPE B*****
CAL (DC)VOLTAGE IN:8.0 V
DISK D: 120cc#2
TRACK ID:7

CAL#1(gage#1)/CHAN 1A: NA
VCAL VOLTAGE OUT:
CAL#2(gage#2)/CHAN 1B:NA
CAL VOLTAGE OUT:
CAL#1(gage#1)/CHAN 1A:8.0 V
CAL VOLTAGE OUT:
CAL#2(gage#2)/CHAN 2A:8.0 V
CAL VOLTAGE OUT:

FIRING

***** SCOPE A*****
DISK ID:ETC#1
TRACK ID:11
SENSITIVITY: MIN
*****SCOPE B*****
DISK ID:120cc#2
TRACK ID:8
SENSITIVITY:MIN

CHANNEL	WINDOW	S.RATE	CHANNEL	WINDOW	S.RATE
1A: P1	50ms	20usxpnt	1A: P1	NA	
1B: P2	50ms	20usxpnt	2A: P2	NA	
2A:di/dt	4ms	.5usxpnt	2A:	NA	
2B: V	4ms	.5usxpnt	1B: ROGOVVKY#2		
ROGOVSKY#1 (m.A/V.s)			ROGOVSKY#2 (m.A/V.s)		

PRESSURE MAX(MPa)
SCOPE ID:B
GAGE ID:#1
PRESSURE MAX(MPa):273
SCOPE ID:B
GAGE ID:#2

ETCTEML1 INFORMATION SHEET FOR ETC CLOSED CHAMBER FIRING
 DATE:03/18/94 SERIES RUN#:3 PROJECT: 129.0 CLOSED CHAMBER
 PROPELLANT TYPE:JA2;7perf;LOT #:RAD-PE-792-71 SAMPLE TREATMENT:70F
 SAMPLE WEIGHT:34.5g GRAIN DIMENSION:0.6"L, 0.3"D; 0.03 WEB
 CHAMBERVOL:129.4cc CALCMAX PRESSURE: 300MPa WINDOW: 2ms
 HIGH DEN. LOADING
 PFNPULSE LENGTH:1.2ms PFN SCHEMATIC#:6caps@830uF ea.&6ind@ 10uHea
 PFN Vin DC:3.0kV; EXPECTED ENERGY:16kJ@ 70%efficy;WINDOW :2ms
 PEARSON'S CAL K:2630;
 vessel's ROGOVSKI#1CAL K:NA ;pfn's ROGOVSKI#2CAL K:82.45E+06

MUZZLE GAGE#1 SN(P1): C47189 SIDE GAGE#2 SN(P2): C42442
 gage#1:1rstdegfit coeff:5.76E-02;gage#2:1rstdegfit coeff:6.0E-02

CALIBRATION

*****SCOPE A*****
 CAL (DC)VOLTAGE IN :NA
 DISK ID: ETC#1
 TRACKID: NA
 CAL#1(gage#1)/CHAN 1A: NA
 VCAL VOLTAGE OUT:
 CAL#2(gage#2)/CHAN 1B:NA
 CAL VOLTAGE OUT:

*****SCOPE B*****
 CAL (DC)VOLTAGE IN:8.0 V
 DISK D: 120cc#2
 TRACK ID:9
 CAL#1(gage#1)/CHAN 1A:8.0 V
 CAL VOLTAGE OUT:
 CAL#2(gage#2)/CHAN 2A:8.0 V
 CAL VOLTAGE OUT:

FIRING

***** SCOPE A*****
 DISK ID:ETC#1
 TRACK ID:12
 SENSITIVITY: MIN

*****SCOPE B*****
 DISK ID:120cc#2
 TRACK ID:10
 SENSITIVITY:MIN

CHANNEL	WINDOW	S.RATE	CHANNEL	WINDOW	S.RATE
1A: P1	50ms	20usxpnt	1A: P1	NA	
1B: P2	50ms	20usxpnt	2A: P2	NA	
2A:di/dt	4ms	.5usxpnt	2A:	NA	
2B: V	4ms	.5usxpnt	1B: ROGOVSKY#2		
ROGOVSKY#1 (m.A/V.s)			ROGOVSKY#2 (m.A/V.s)		

PRESSURE MAX(MPa)
 SCOPE ID:B
 GAGE ID:#1

PRESSURE MAX(MPa):400
 SCOPE ID:B
 GAGE ID:#2

ETCTEML1 INFORMATION SHEET FOR ETC CLOSED CHAMBER FIRING
 DATE:02/09/95 SERIES RUN#:5 PROJECT: 129.0 CLOSED CHAMBER
 PROPELLANT TYPE:JA2;7perf;LOT #:RAD-PE-792-71 SAMPLE TREATMENT:70F
 SAMPLE WEIGHT:27.23g GRAIN DIMENSION:0.6"L, 0.3"D; 0.03 WEB
 CHAMBERVOL:129.4cc CALCMAX PRESSURE: 300MPa WINDOW: 4ms
 HIGH DEN. LOADING
 PFNPULSE LENGTH:1.2ms PFN SCHEMATIC#:6caps@830uF ea.&6ind@ 10uHea
 PFN Vin DC:4.0kV; EXPECTED ENERGY:16kJ@ 70%efficy;WINDOW :2ms
 PEARSON'S CAL K:2630;
 vessel's ROGOVSKI#1CAL K:82.45e+06;pfn's ROGOVSKI#2CAL K:80.49E+06

MUZZLE GAGE#1 SN(P1): C47189 SIDE GAGE#2 SN(P2): C19928
 gage#1:1rstdegfit coeff:5.76E-02;gage#2:1rstdegfit coeff:6.0E-02

CALIBRATION

*****SCOPE A*****
 CAL (DC)VOLTAGE IN :NA
 DISK ID: ETC#3
 TRACKID: NA
 CAL#1(gage#1)/CHAN 1A: NA
 VCAL VOLTAGE OUT:
 CAL#2(gage#2)/CHAN 1B:NA
 CAL VOLTAGE OUT:

*****SCOPE B*****
 CAL (DC)VOLTAGE IN:8.0 V
 DISK D: 120cc#4
 TRACK ID:16
 CAL#1(gage#1)/CHAN 1A:8.0 V
 CAL VOLTAGE OUT: 9.25
 CAL#2(gage#2)/CHAN 2A:8.0 V
 CAL VOLTAGE OUT: 9.161

FIRING

***** SCOPE A*****
 DISK ID:ETC#1
 TRACK ID:5
 SENSITIVITY: MIN

*****SCOPE B*****
 DISK ID:120cc#4
 TRACK ID:17
 SENSITIVITY:MIN

CHANNEL	WINDOW	S.RATE	CHANNEL	WINDOW	S.RATE
1A: P1	50ms	20usxpnt	1A: P1	20ms	5usxpnt
1B: P2	50ms	20usxpnt	2A: P2	20ms	5usxpnt
2A:di/dt	4ms	.5usxpnt	2A: NA		
2B: V	4ms	.5usxpnt	1B: ROGOVSKY#2		
ROGOVSKY#1 (m.A/V.s)			ROGOVSKY#2 (m.A/V.s)		

PRESSURE MAX(MPa)
 SCOPE ID:B
 GAGE ID:#1

PRESSURE MAX(MPa):300
 SCOPE ID:B
 GAGE ID:#2

APPENDIX C:
EXPERIMENTAL PRESSURE AND PULSER ENERGY OUTPUT

INTENTIONALLY LEFT BLANK.

Pressure and PFN energy output for ident 03154S1, 03154S2, 03154S3, and 02095S5 are shown in Figures C-1 thru C-8, as ident 02095S5 was the closest match for these three previous firings.

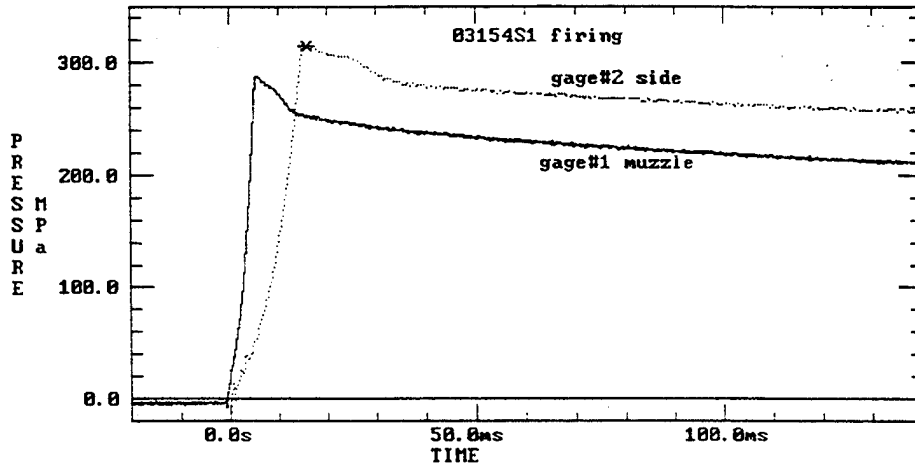

Figure C-1. Ident 03154S1 (ETC firing), pressure vs. time.

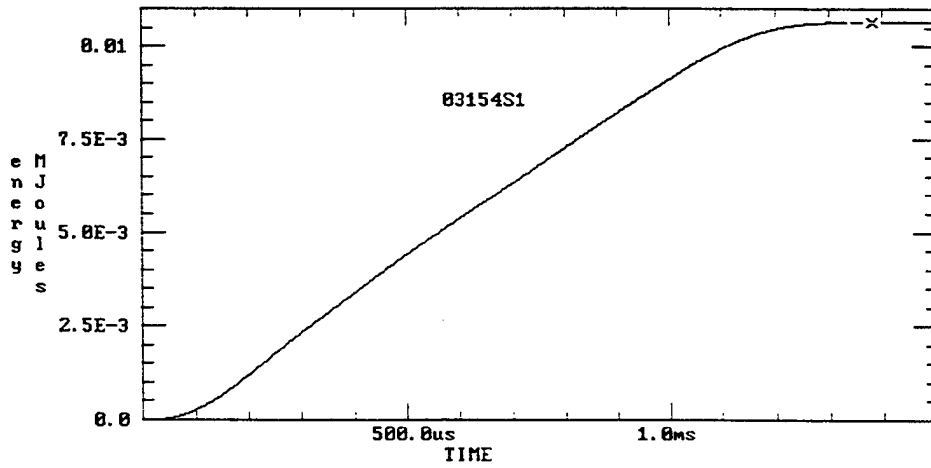

Figure C-2. Ident 03154S1 (ETC firing), energy vs. time.

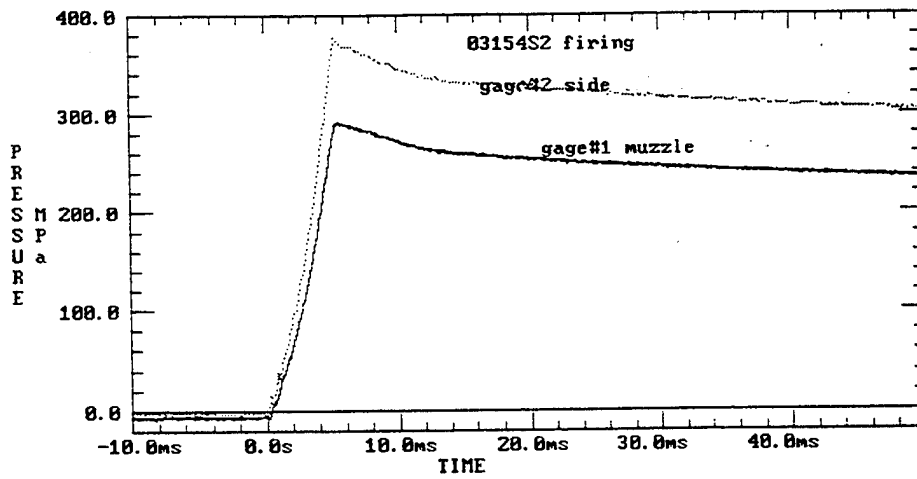

Figure C-3. Ident 03154S2 (ETC firing), pressure vs. time.

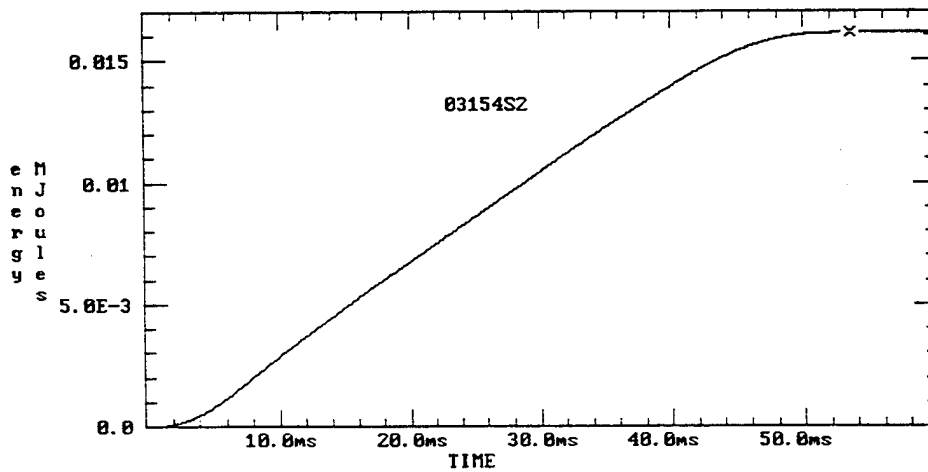

Figure C-4. Ident 03154S2 (ETC firing), energy vs. time.

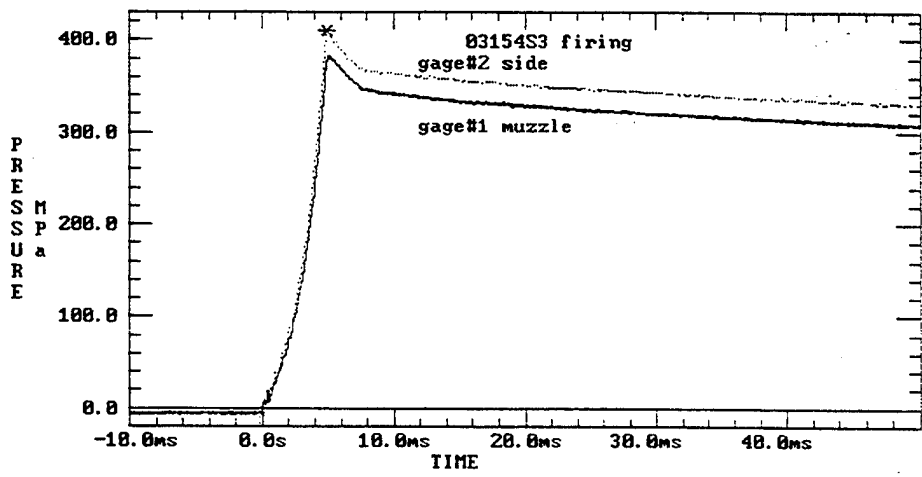

Figure C-5. Ident 03154S3 (ETC firing), pressure vs. time.

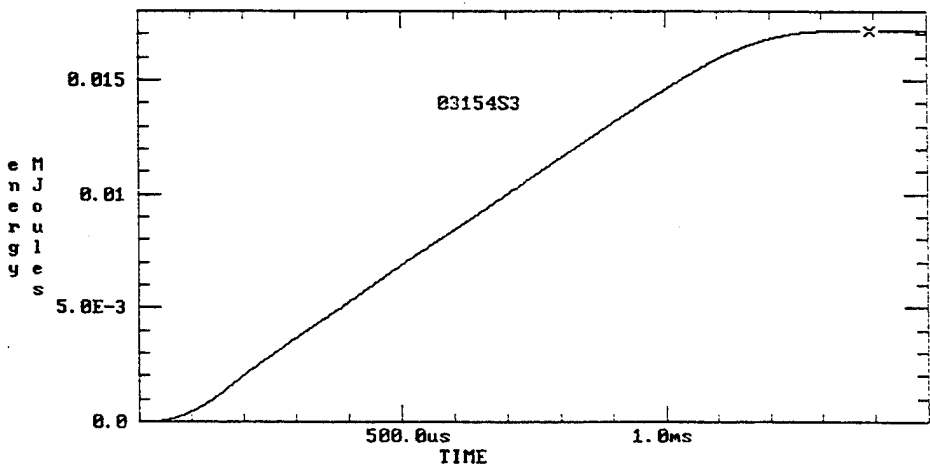

Figure C-6. Ident 03154S3 (ETC firing), energy vs. time.

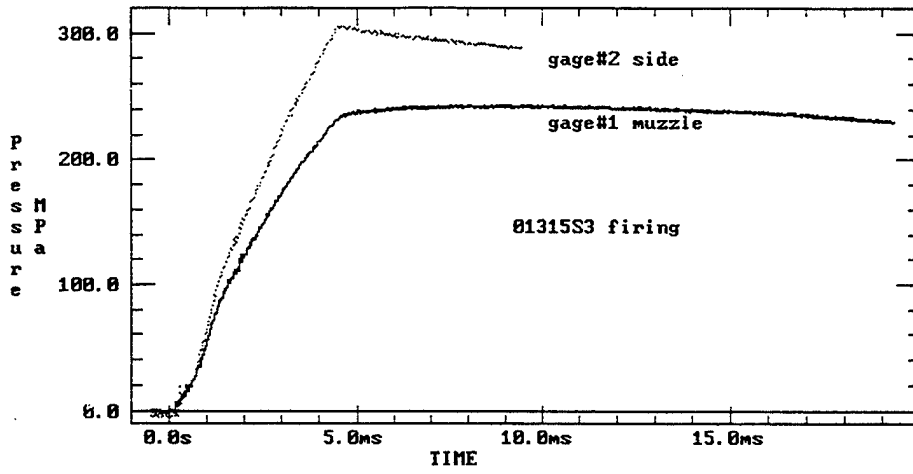

Figure C-7. Ident 01315S3 (ETC firing), pressure vs. time.

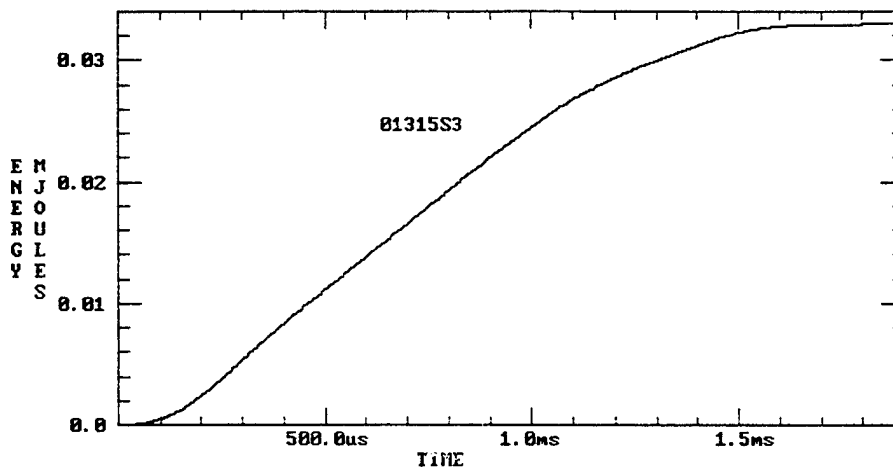

Figure C-8. Ident 01315S3 (ETC firing), energy vs. time.

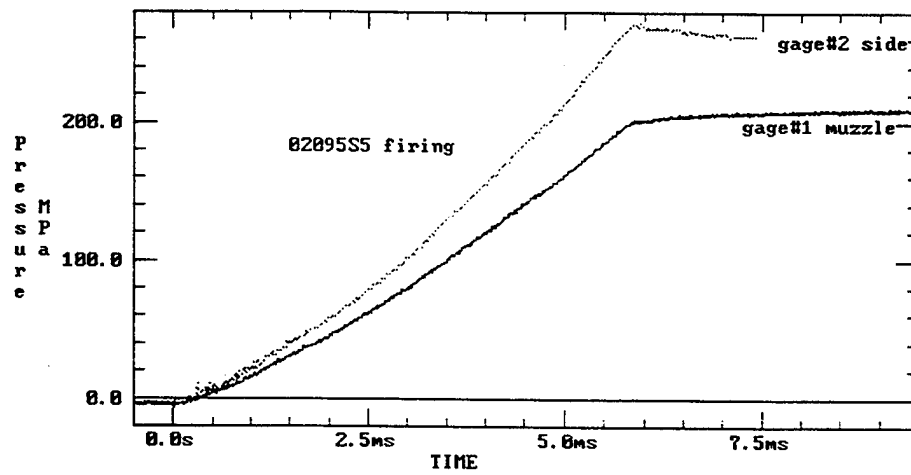

Figure C-9. Ident 02095S5 (ETC firing), pressure vs. time.

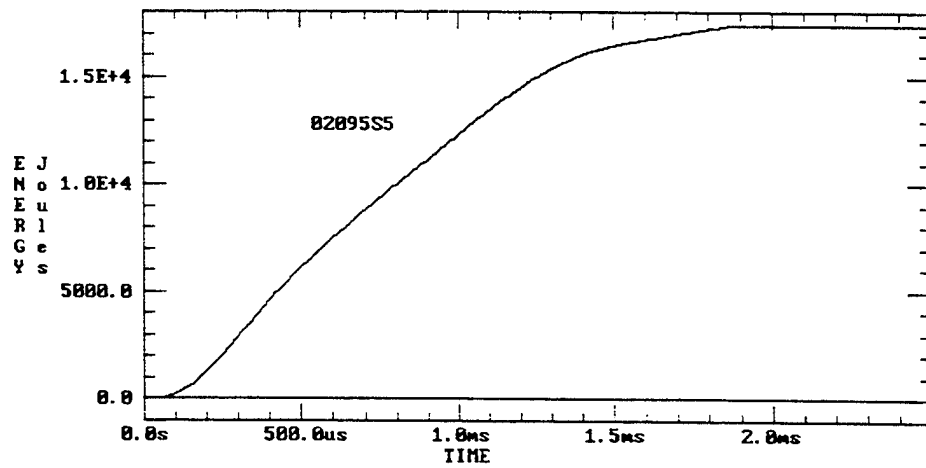

Figure C-10. Ident 02095S5 (ETC firing), energy vs. time.

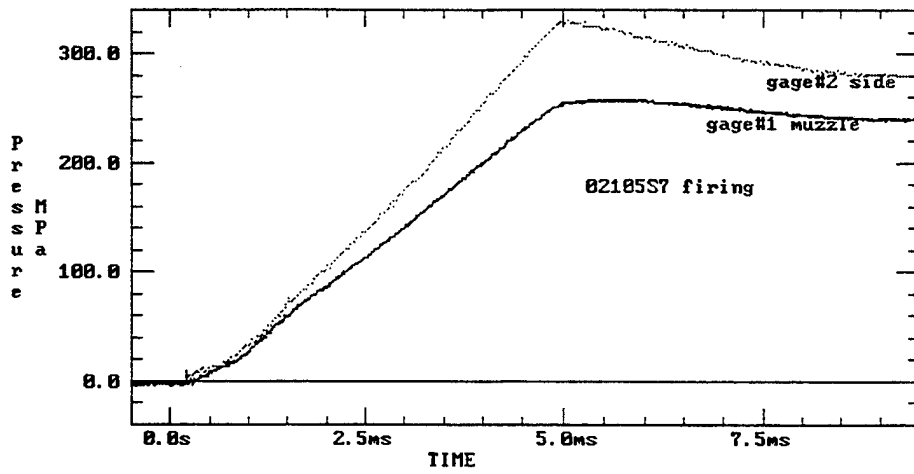

Figure C-11. Ident 02105S7 (ETC firing), pressure vs. time.

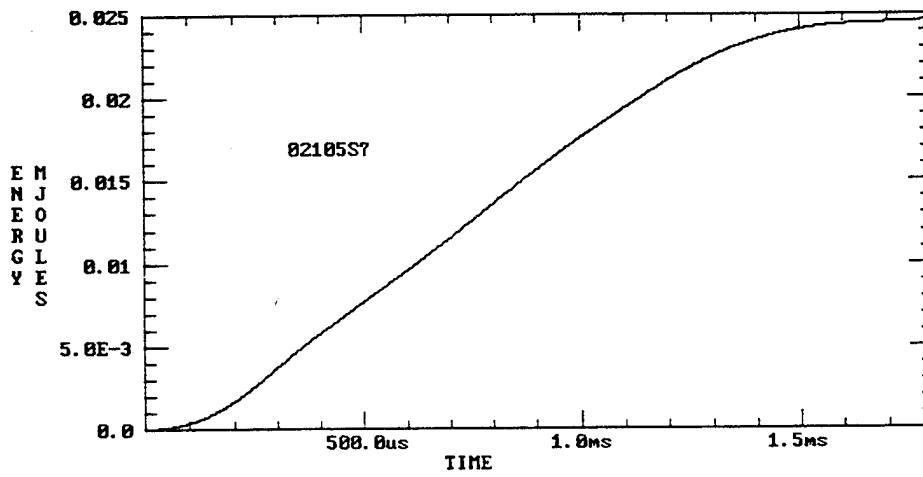

Figure C-12. Ident 02105S7 (ETC firing), energy vs. time.

**APPENDIX D:
BURN RATES**

INTENTIONALLY LEFT BLANK.

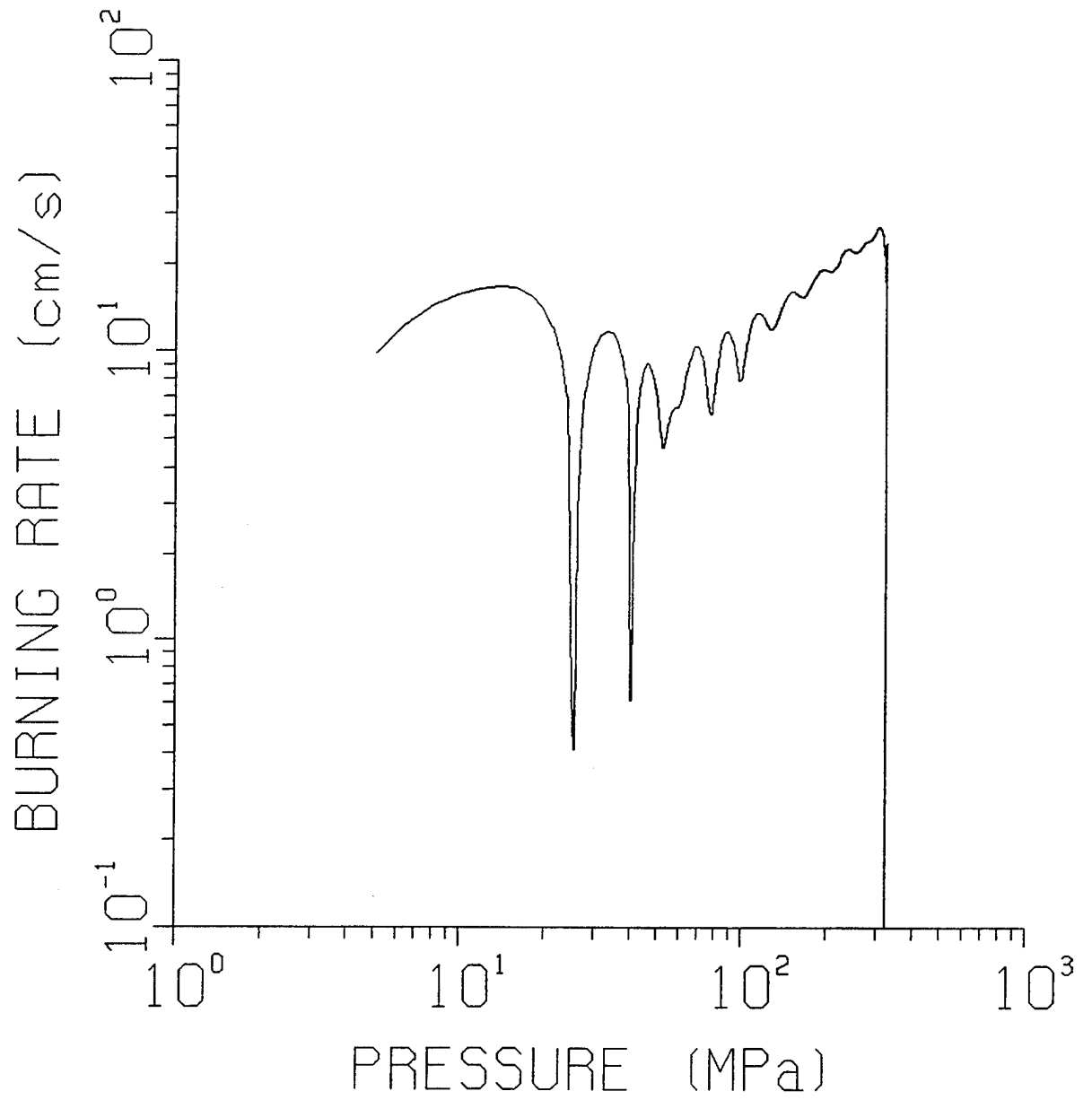

Figure D-1. Burn rate ident 03154S1.

ETC BURN RATE ANALYSIS
BRLCB V3.0
ADVANCED BALLISTIC CONCEPTS BRANCH - BRL

Project : ja2 Requested by : guercio
Inf File: 03154S1.inf Created From .MAS File : ja2.mas
P/T File: 03154S1.pvt Calculation Output File: 03154S1.out
Smoothed: 03154S1.pdt Graphics File : 03154S1.dat
EE File: A:03154S1E.AD

Fired on: 03/15/94
FIRING REMARKS:
JA2 DISKS, ETC 3KV, 6CAPS & 6 IND, 1.2ms pulse
REDUCTION REMARKS:
03/15/94

IGNITER INFORMATION

The Igniter Used Is : Black Powder Lot: FFFG
The Source For The Igniter Is: Pellets, Milan Ord.

IGNITER THERMOCHEMICAL PROPERTIES:

Impetus (J/g) : 290.0 Molecular Weight : 66.37000
Flame Temperature (K): 2188.0 Covolume (cc/g) : .78500
Density (g/cc) : 1.75000 Gamma : 1.21840

PROPELLANT INFORMATION

The Propellant Used Is : Lot:
The Source For The Propellant Is:

Propellant Thermochemical Properties: Following
Sheets of Output

PROPELLANT GRAIN GEOMETRY

Grain Type: 1-Perf. Cyl.
Length --- (cm.): .139700
Outer Diam.(cm.): 2.882900
Perf Diam. (cm.): 1.270000
Inner Web (cm.): .806450

Bomb Information

Bomb Type : Closed Chamber
Bomb Vol (cc): 129.4

Gage Information

Gage I.D. : C42442
Input Voltage: 8.0000
Constants For Fit: A+Bx+C^2
A: .75318E-01
B: .63631E-01
C: -.42344E-06

Temperature and Charge Mass Information

Propellant Mass (g) : 27.5000 Igniter Mass (g): .0000
Initial Temp. Prop.(K): 294. Igniter Temp.(K): 294.
Initial Bomb Temp. (K): 294.
Number of Propellant Grains: 23.39

Number of Wildpoint Passes: 1 Wildpoint Tolerance: 5.000
Number of Smoothing Passes: 1 Smoothing Option: 1
Bridge Length: 15

1 OUTPUT FILE: 03154s1.op7

Total # Layers = 1

Chamber Volume (cm3) = 129.400

Heat-Loss-Fraction (n-d) = .000

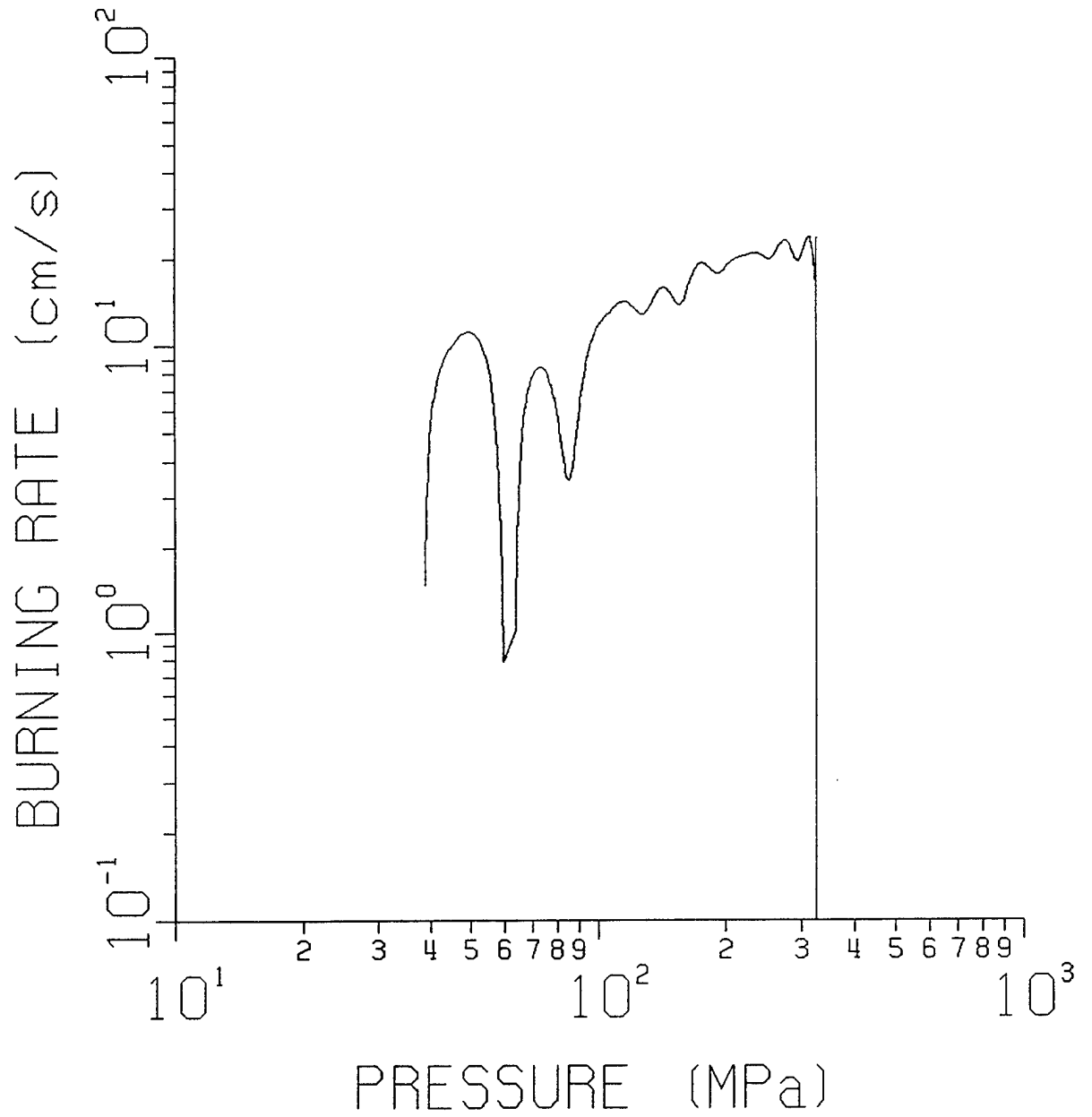

Figure D-2. Burn rate ident 03154S2.

ETC BURN RATE ANALYSIS
BRLCB V3.0
ADVANCED BALLISTIC CONCEPTS BRANCH - BRL

Project : ja2 Requested by : guercio
Inf File: 03154S2.inf Created From .MAS File : ja2.mas
P/T File: 03154S2.pvt Calculation Output File: 03154S2.out
Smoothed: 03154S2.pdt Graphics File : 03154S2.dat
EE File: A:03154S2E.AD
Fired on: 03/15/94 SERIES II
FIRING REMARKS:
JA2 DISKS, ETC, 3KV, 1.2ms pulse, 6cps& 6 ind

IGNITER INFORMATION

The Igniter Used Is : Black Powder Lot: FFFG
The Source For The Igniter Is: Pellets, Milan Ord.

IGNITER THERMOCHEMICAL PROPERTIES:

Impetus (J/g) : 290.0 Molecular Weight : 66.37000
Flame Temperature (K): 2188.0 Covolume (cc/g) : .78500
Density (g/cc) : 1.75000 Gamma : 1.21840

PROPELLANT INFORMATION

The Propellant Used Is : Lot:
The Source For The Propellant Is:

Propellant Thermochemical Properties: Following
Sheets of Output

PROPELLANT GRAIN GEOMETRY

Grain Type:1-Perf. Cyl.
Length --- (cm.): .139700
Outer Diam.(cm.): 2.882900
Perf Diam. (cm.): 1.270000
Inner Web (cm.): .806450

Bomb Information

Gage Information

Bomb Type :Closed Chamber Gage I.D. : C42442
Bomb Vol (cc): 129.4 Input Voltage: 8.0000
Constants For Fit: A+Bx+C^2
A: .75318E-01
B: .63631E-01
C: -.42344E-06

Temperature and Charge Mass Information

Propellant Mass (g) : 27.6920 Igniter Mass (g): .0000
Initial Temp. Prop.(K): 294. Igniter Temp.(K): 294.
Initial Bomb Temp. (K): 294.
Number of Propellant Grains: 23.56

Number of Wildpoint Passes: 1 Wildpoint Tolerance: 5.000
Number of Smoothing Passes: 1 Smoothing Option: 1
Bridge Length: 15

1 OUTPUT FILE: 03154s2.op7

Total # Layers = 1

Chamber Volume (cm³) = 129.400

Heat-Loss-Fraction (n-d) = .000

Time Step (mil-sec) = .20000000E-01 Max Time Steps = 1200

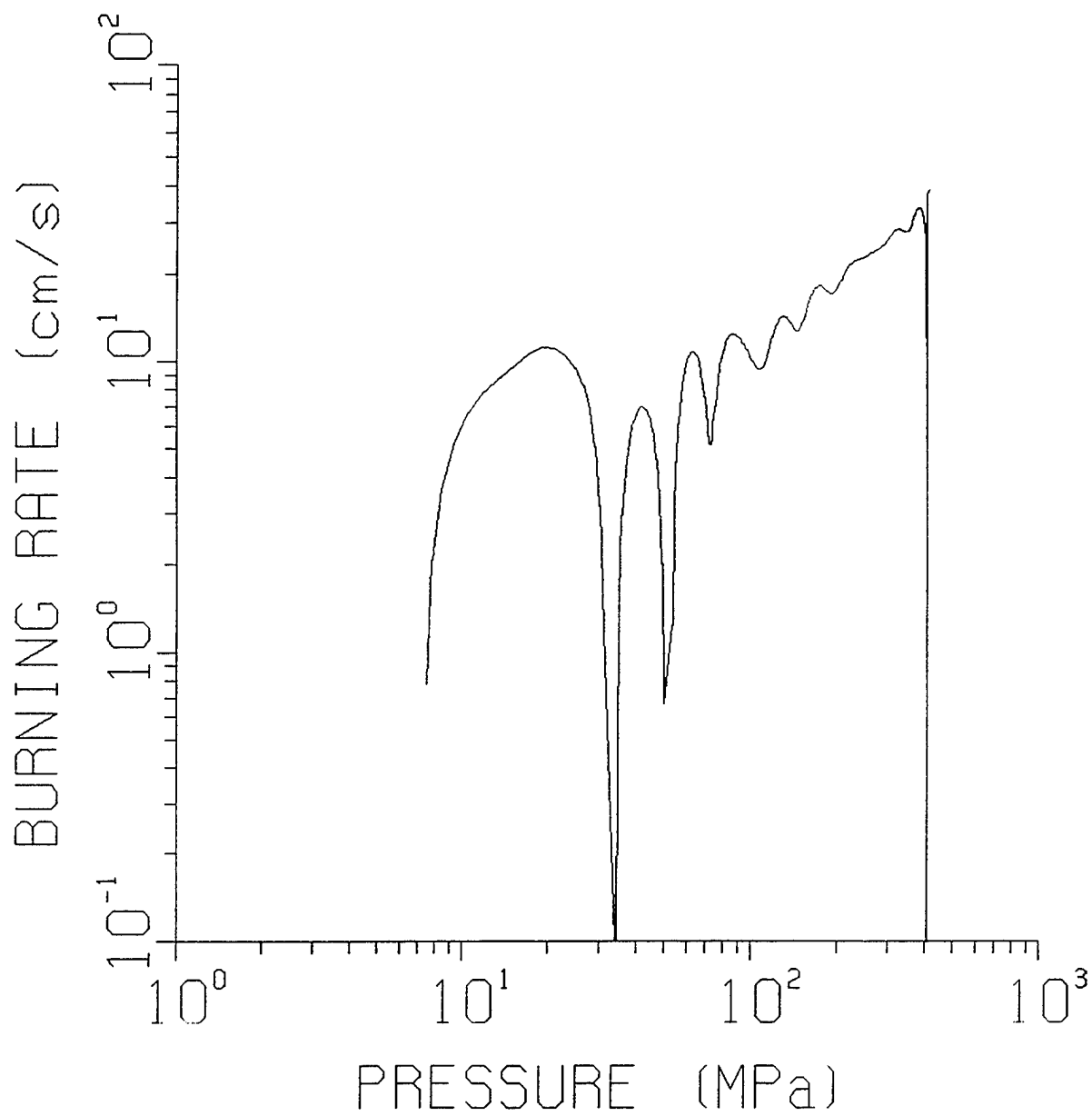

Figure D-3. Burn rate ident 03184S3.

ETC BURN RATE ANALYSIS
BRLCB V3.0
ADVANCED BALLISTIC CONCEPTS BRANCH - BRL

Project : ja2 Requested by : guercio
Inf File: 03184S3.inf Created From .MAS File : ja2.mas
P/T File: 03184S3.pvt Calculation Output File: 03184S3.out
Smoothed: 03184S3.pdt Graphics File : 03184S3.dat
EE File: A:03184S3E.AD
Fired on: 03/18/94 SEREIES III
FIRING REMARKS:
JA2 DISKS, ETC, 1.2ms, 3kv, 6ind & 6 caps
high density loading

IGNITER INFORMATION

The Igniter Used Is : Black Powder Lot: FFFG
The Source For The Igniter Is: Pellets, Milan Ord.

IGNITER THERMOCHEMICAL PROPERTIES:

Impetus (J/g) : 290.0 Molecular Weight : 66.37000
Flame Temperature (K): 2188.0 Covolume (cc/g) : .78500
Density (g/cc) : 1.75000 Gamma : 1.21840

PROPELLANT INFORMATION

The Propellant Used Is : Lot:
The Source For The Propellant Is:

Propellant Thermochemical Properties: Following
Sheets of Output

PROPELLANT GRAIN GEOMETRY

Grain Type:1-Perf. Cyl.
Length --- (cm.): .139700
Outer Diam.(cm.): 2.882900
Perf Diam. (cm.): 1.270000
Inner Web (cm.): .806450

Bomb Information

Bomb Type :Closed Chamber
Bomb Vol (cc): 129.4

Gage Information

Gage I.D. : C42442
Input Voltage: 8.0000
Constants For Fit: A+Bx+C^2
A: .75318E-01
B: .63631E-01
C: -.42344E-06

Temperature and Charge Mass Information

Propellant Mass (g) : 34.5000 Igniter Mass (g): .0000
Initial Temp. Prop.(K): 294. Igniter Temp.(K): 294.
Initial Bomb Temp. (K): 294.
Number of Propellant Grains: 29.35

Number of Wildpoint Passes: 1 Wildpoint Tolerance: 5.000
Number of Smoothing Passes: 1 Smoothing Option: 1
Bridge Length: 15

1 OUTPUT FILE: 03184s3.op7

Total # Layers = 1

Chamber Volume (cm³) = 129.400

Heat-Loss-Fraction (n-d) = .000

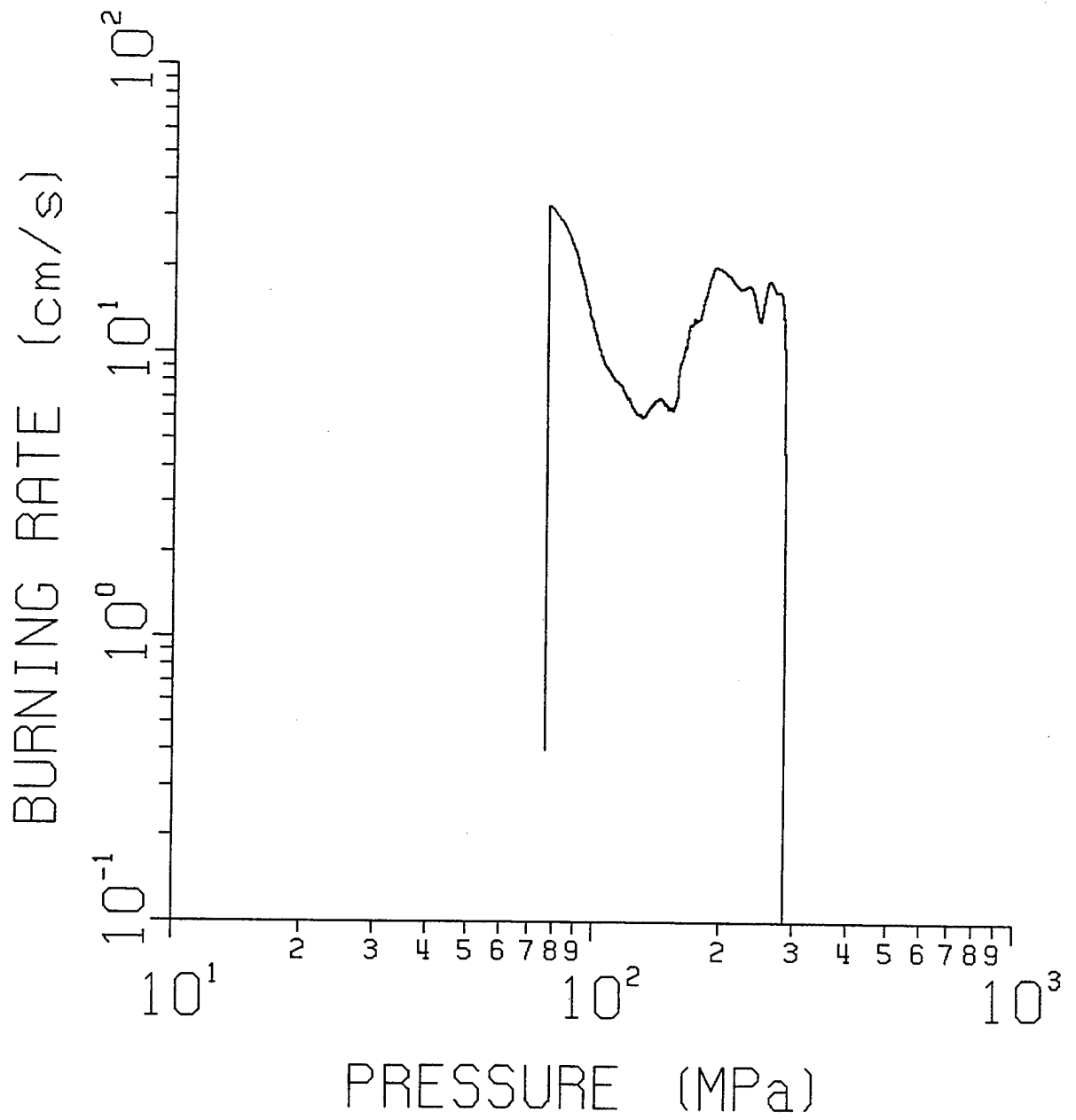

Figure D-4. Burn rate ident 01315S3.

ETC BURN RATE ANALYSIS
BRLCB V3.0
ADVANCED BALLISTIC CONCEPTS BRANCH - BRL

Project : ja2 Requested by : guercio
Inf File: 01315S3.inf Created From .MAS File : ja2.mas
P/T File: 01315S3.pvt Calculation Output File: 01315S3.out
Smoothed: 01315S3.pdt Graphics File : 01315S3.dat
EE File: A:01315S3E.AD
Fired on: 01/31/95
FIRING REMARKS:
ETC, 5kV, 1.2 ms pulse length, 4 caps & 4 inductors
27.11g JA2 disks

IGNITER INFORMATION

The Igniter Used Is : Black Powder Lot: FFFG
The Source For The Igniter Is: Pellets, Milan Ord.

IGNITER THERMOCHEMICAL PROPERTIES:

Impetus (J/g) : 290.0 Molecular Weight : 66.37000
Flame Temperature (K): 2188.0 Covolume (cc/g) : .78500
Density (g/cc) : 1.75000 Gamma : 1.21840

PROPELLANT INFORMATION

The Propellant Used Is : Lot:
The Source For The Propellant Is:

Propellant Thermochemical Properties: Following
Sheets of Output

PROPELLANT GRAIN GEOMETRY

Grain Type: 1-Perf. Cyl.
Length --- (cm.): .139700
Outer Diam.(cm.): 2.882900
Perf Diam. (cm.): 1.270000
Inner Web (cm.): .806450

Bomb Information

Bomb Type : Closed Chamber
Bomb Vol (cc): 129.4

Gage Information

Gage I.D. : C19928
Input Voltage: 8.0000
Constants For Fit: A+Bx+C^2
A: .21637E+00
B: .54171E-01
C: -.31853E-06

Temperature and Charge Mass Information

Propellant Mass (g) : 27.1100 Igniter Mass (g): .0000
Initial Temp. Prop.(K): 294. Igniter Temp.(K): 294.
Initial Bomb Temp. (K): 294.
Number of Propellant Grains: 23.06

Number of Wildpoint Passes: 1 Wildpoint Tolerance: 5.000
Number of Smoothing Passes: 1 Smoothing Option: 1
Bridge Length: 15
1 OUTPUT FILE: 01315s3.op7

Total # Layers = 1

Chamber Volume (cm3) = 129.400

Heat-Loss-Fraction (n-d) = .000

Time Step (mil-sec) = .50000000E-02 Max Time Steps = 1200

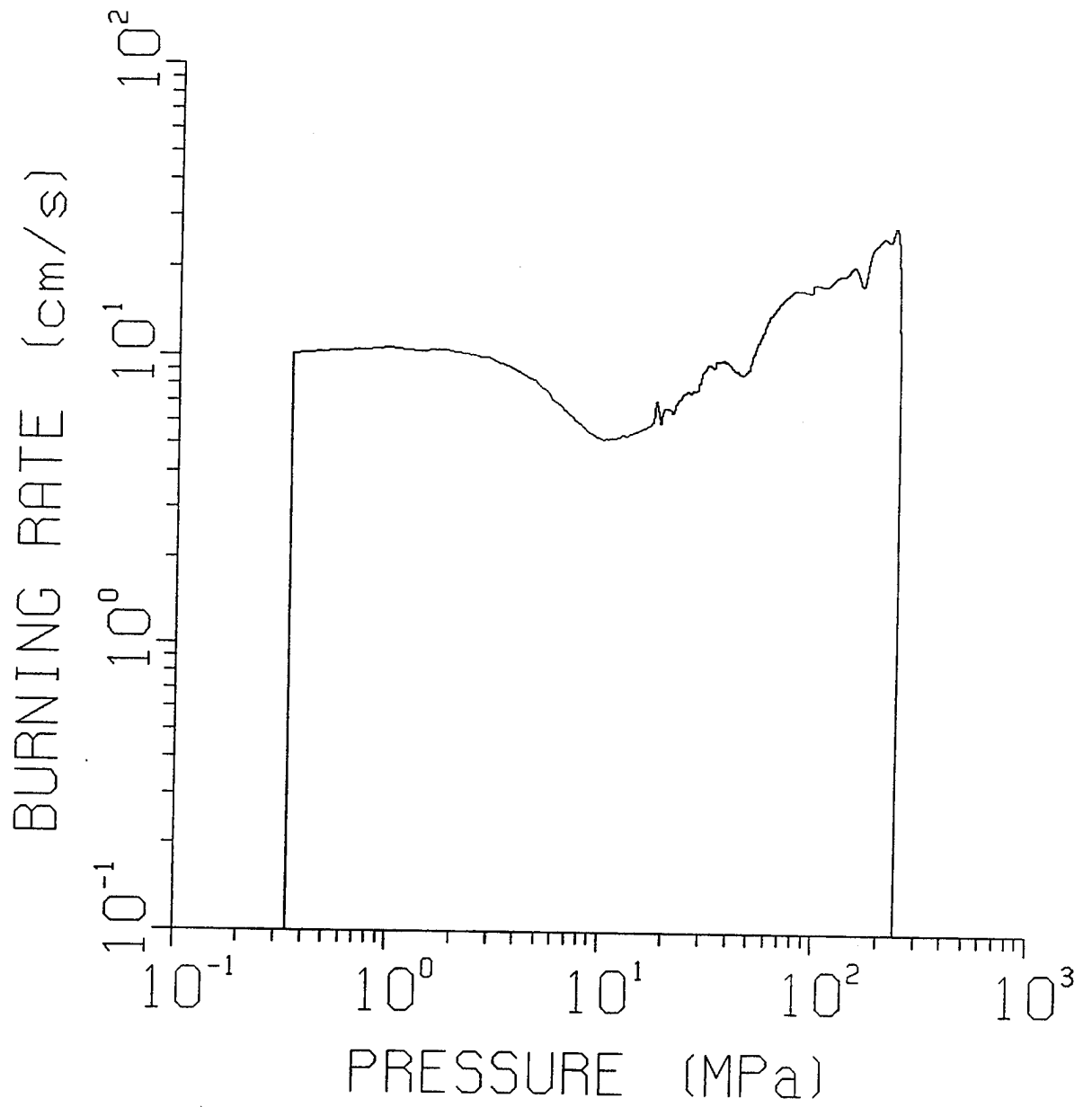

Figure D-5. Burn rate ident 02095S5.

ETC BURN RATE ANALYSIS
BRLCB V3.0
ADVANCED BALLISTIC CONCEPTS BRANCH - BRL

Project : ja2 Requested by : guercio
Inf File: 02095S5.inf Created From .MAS File : ja2.mas
P/T File: 02095S5.pvt Calculation Output File: 02095S5.out
Smoothed: 02095S5.pdt Graphics File : 02095S5.dat
EE File: 02095S5E.AD
Fired on: 02/09/95
FIRING REMARKS:
JA2, ETC 4CAPS AND 4 IND, REPRODUCE 1.2ms pulse of 300kJ PFN
ENERGY MATCHED: 18KJ

IGNITER INFORMATION

The Igniter Used Is : Black Powder Lot: FFFG
The Source For The Igniter Is: Pellets, Milan Ord.

IGNITER THERMOCHEMICAL PROPERTIES:

Impetus (J/g) : 290.0 Molecular Weight : 66.37000
Flame Temperature (K): 2188.0 Covolume (cc/g) : .78500
Density (g/cc) : 1.75000 Gamma : 1.21840

PROPELLANT INFORMATION

The Propellant Used Is : Lot:
The Source For The Propellant Is:

Propellant Thermochemical Properties: Following
Sheets of Output

PROPELLANT GRAIN GEOMETRY

Grain Type:1-Perf. Cyl.
Length --- (cm.): .139700
Outer Diam.(cm.): 2.882900
Perf Diam.(cm.): 1.270000
Inner Web (cm.): .806450

Bomb Information

Bomb Type :Closed Chamber
Bomb Vol (cc): 129.4

Gage Information

Gage I.D. : C19928
Input Voltage: 8.0000
Constants For Fit: A+Bx+C^2
A: .21637E+00
B: .54171E-01
C: -.31853E-06

Temperature and Charge Mass Information

Propellant Mass (g) : 27.2300 Igniter Mass (g): .0000
Initial Temp. Prop.(K): 294. Igniter Temp.(K): 294.
Initial Bomb Temp. (K): 294.
Number of Propellant Grains: 23.16

Number of Wildpoint Passes: 1 Wildpoint Tolerance: 5.000
Number of Smoothing Passes: 1 Smoothing Option: 1
Bridge Length: 15

1 OUTPUT FILE: 02095S5.OP7

Total # Layers = 1

Chamber Volume (cm³) = 129.400

Heat-Loss-Fraction (n-d) = .000

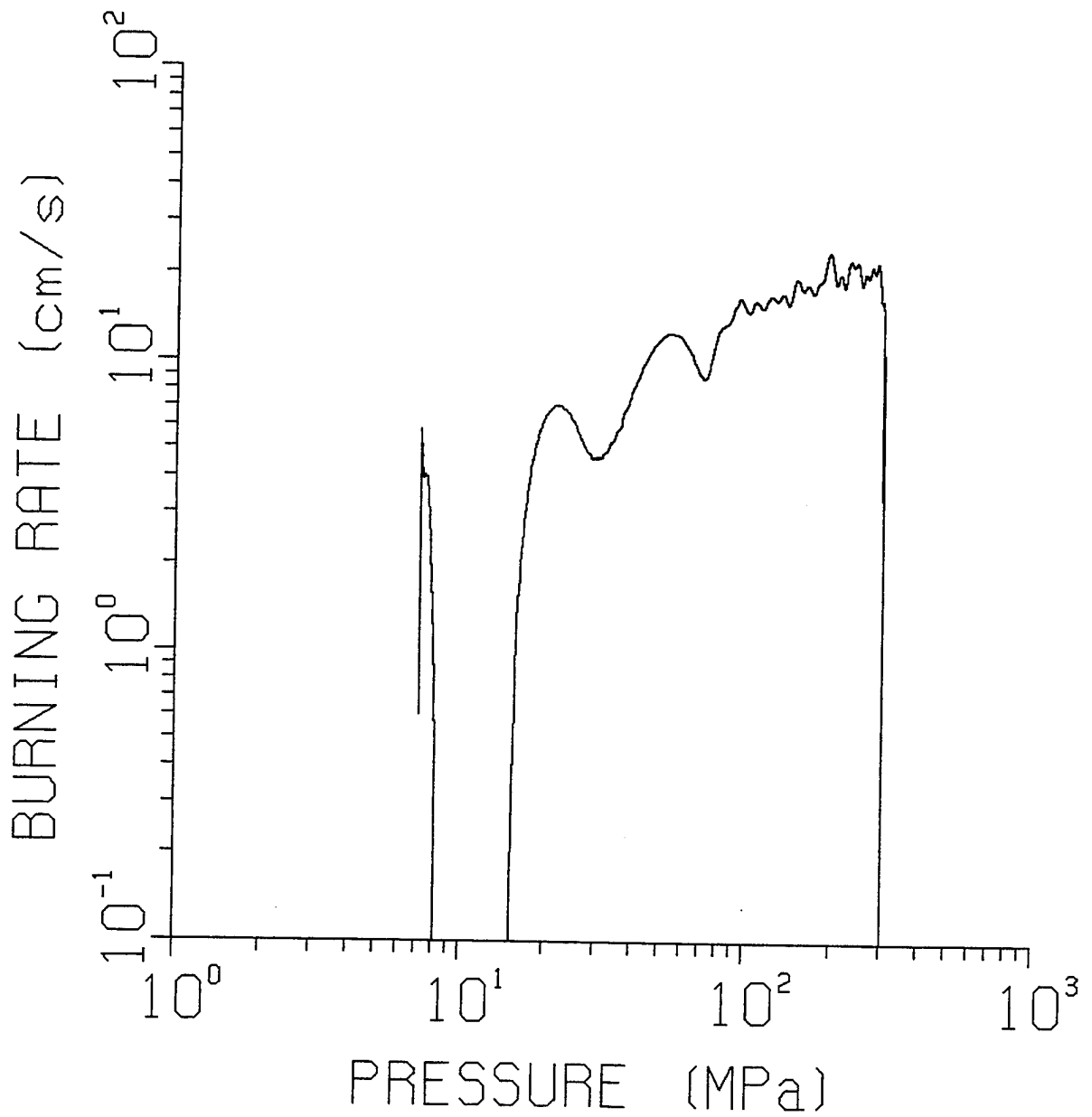

Figure D-6. Burn rate ident 02105S7.

ETC BURN RATE ANALYSIS
BRLCB V3.0
ADVANCED BALLISTIC CONCEPTS BRANCH - BRL

Project : ja2 Requested by : guercio
Inf File: 02105S7.inf Created From .MAS File : ja2.mas
P/T File: 02105S7.pvt Calculation Output File: 02105S7.out
Smoothed: 02105S7.pdt Graphics File : 02105S7.dat
EE File: 02105S7E.AD
Fired on: 02/10/95 ETC JA2

FIRING REMARKS:
02105S7V.AD WAS LOW PASS FILTERED 5000/500HZ
NEW E-LINER/THREADED NOZZLE
E-LINER DID NOT FRAGMENT AFTER FIRING @4kJ

IGNITER INFORMATION

The Igniter Used Is : Black Powder Lot: FFFG
The Source For The Igniter Is: Pellets, Milan Ord.

IGNITER THERMOCHEMICAL PROPERTIES:

Impetus (J/g) : 290.0 Molecular Weight : 66.37000
Flame Temperature (K): 2188.0 Covolume (cc/g) : .78500
Density (g/cc) : 1.75000 Gamma : 1.21840

PROPELLANT INFORMATION

The Propellant Used Is : Lot:
The Source For The Propellant Is:

Propellant Thermochemical Properties: Following
Sheets of Output

PROPELLANT GRAIN GEOMETRY

Grain Type:1-Perf. Cyl.
Length --- (cm.): .139700
Outer Diam.(cm.): 2.882900
Perf Diam. (cm.): 1.270000
Inner Web (cm.): .806450

Bomb Information

Gage Information

Bomb Type :Closed Chamber Gage I.D. : C19928
Bomb Vol (cc): 129.4 Input Voltage: 8.0000
Constants For Fit: A+Bx+C^2
A: .21637E+00
B: .54171E-01
C: -.31853E-06

Temperature and Charge Mass Information

Propellant Mass (g) : 27.1300 Igniter Mass (g): .0000
Initial Temp. Prop.(K): 294. Igniter Temp.(K): 294.
Initial Bomb Temp. (K): 294.
Number of Propellant Grains: 23.08

Number of Wildpoint Passes: 1 Wildpoint Tolerance: 5.000
Number of Smoothing Passes: 1 Smoothing Option: 1
Bridge Length: 15

1 OUTPUT FILE: 02105S7.OP7

Total # Layers = 1

Chamber Volume (cm³) = 129.400

Heat-Loss-Fraction (n-d) = .000

NO. OF
COPIES ORGANIZATION

2 DEFENSE TECHNICAL INFO CTR
ATTN DTIC DDA
8725 JOHN J KINGMAN RD
STE 0944
FT BELVOIR VA 22060-6218

1 DIRECTOR
US ARMY RESEARCH LAB
ATTN AMSRL OP SD TA
2800 POWDER MILL RD
ADELPHI MD 20783-1145

3 DIRECTOR
US ARMY RESEARCH LAB
ATTN AMSRL OP SD TL
2800 POWDER MILL RD
ADELPHI MD 20783-1145

1 DIRECTOR
US ARMY RESEARCH LAB
ATTN AMSRL OP SD TP
2800 POWDER MILL RD
ADELPHI MD 20783-1145

ABERDEEN PROVING GROUND

5 DIR USARL
ATTN AMSRL OP AP L (305)

NO. OF
COPIES ORGANIZATION

NO. OF
COPIES ORGANIZATION

1 HQDA
ATTN SARD TR
K KOMINOS
PENTAGON
WASHINGTON DC 20310-0103

1 HQDA
ATTN SARD TR
R CHAIT
PENTAGON
WASHINGTON DC 20310-0103

1 DIRECTOR
ARMY RESEARCH OFFICE
ATTN AMXRO MCS K CLARK
PO BOX 12211
RESEARCH TRIANGLE PARK NC
27709-2211

1 DIRECTOR
ARMY RESEARCH OFFICE
ATTN AMXRO RT IP LIB SERV
PO BOX 12211
RESEARCH TRIANGLE PARK
27709-2211

ABERDEEN PROVING GROUND

126 DIR, USARL
ATTN: AMSRL-SC,
W. MERMAGEN
W. STUREK
AMSRL-SC-C, H. BREAUX
AMSRL-SC-CC,
J. GROSH
A. CELMINS
AMSRL-SC-S, A. MARK
AMSRL-SL-B, P. DEITZ (328)
AMSRL-SL-BA, J. MORRISSEY (433)
AMSRL-SL-BG, A. YOUNG (238)
AMSRL-SL-BL, M. RITONDO (328)
AMSRL-SL,BS, D. BELY (328)
AMSRL-SL-BV, R. SANDMEYER (247)
AMSRL-SL-I, M. STARKS (433)
AMSRL-WT,
D. ECCLESHALL
I. MAY
J. ROCCHIO
AMSRL-WT-P, A. HORST

AMSRL-WT-PA,
R. ANDERSON
A. BIRK
C. BULLOCK
A. BRANT
L-M. CHANG
T. COFFEE
J. COLBURN
P. CONROY
M. DEL GUERCIO (5 CP)
J. DESPIRITO
S. FORTIER
J. HEWITT
S. HOWARD
A. JOHNSON
A. JUHASZ
G. KATULKA
G. KELLER
M. KIWAN
J. KNAPTON
D. KOOKER
D. KRUCZYNSKI
C. LEVERITT
M. MCQUAID
T. MINOR
M. NUSCA
K. NEKULA
W. OBERLE
P. REEVES
M. RIDGLEY
T. ROSENBERGER
C. RUTH
I. STOBIE
P. TRAN
J. TUERK
K. WHITE
A. WILLIAMS
G. WREN
AMSRL-WT-PB,
M. BUNDY
P. PLOSTINS
AMSRL-WT-PC,
G. ADAMS
W. ANDERSON
R. BEYER
S. BUNTE
A. COHEN
R. FIFER

NO. OF
COPIES ORGANIZATION

NO. OF
COPIES ORGANIZATION

ABERDEEN PROVING GROUND (CONT)

AMSRL-WT-PC (CONT)

B. FORCH
J. HEIMERL
A. KOTLAR
M. MILLER
L. SEGER
A. MIZIOLEK
M. SCHROEDER
J. VANDERHOFF
S. MEDLIN
K. MCNESBY
N. FELL
J. WIDDER
J. MORRIS
S. NEWTON
R. PESCE-RODRIGUEZ

AMSRL-WT-PD,

A. ABRAHAMIAN
J. BENDER
B. BURNS
M. LEADORE
G. GAZONAS
R. LIEB
C. HOPPEL
L. BURTON
W. DRYSDALE
T. ERLINE
A. FRYDMAN
D. HOPKINS
R. KASTE
S. WILKERSON

AMSRL-WT-T, W. MORRISON

AMSRL-WT-TA,

M. BURKINS
W. GILLICH

AMSRL-WT-TB,

K. BENJAMIN
R. FREY

AMSRL-WT-TC,

W. DE ROSSET
B. SORENSEN
G. SILSBY

AMSRL-WT-TD, A. DIETRICH

AMSRL-WT-W, C. MURPHY

AMSRL-WT-WA,

A. BARAN
B. MOORE
H. ROGERS

AMSRL-WT-WB,

F. BRANDON

W. D'AMICO

AMSRL-WT-WC,

T. BROSSAU

B. HAUG

AMSRL-WT-WD,

A. NILER

F. PIERCE

AMSRL-WT-WE, J. THOMAS

AMSRL-MA, L. JOHNSON

AMSRL-MA-A,

J. PLUMER

K. BAMBERG

AMSRL-MA-P,

D. VIECHNICKI

R. SHULFORD

M. ROYLANCE

P. TOUCHET

AMSRL-MA-C,

T. HAYNES

W. ROY

R. ADLER

S. CHOU

INTENTIONALLY LEFT BLANK.

USER EVALUATION SHEET/CHANGE OF ADDRESS

This Laboratory undertakes a continuing effort to improve the quality of the reports it publishes. Your comments/answers to the items/questions below will aid us in our efforts.

1. ARL Report Number/Author ARL-TN-66 (Del Guercio) Date of Report May 1996

2. Date Report Received _____

3. Does this report satisfy a need? (Comment on purpose, related project, or other area of interest for which the report will be used.) _____

4. Specifically, how is the report being used? (Information source, design data, procedure, source of ideas, etc.) _____

5. Has the information in this report led to any quantitative savings as far as man-hours or dollars saved, operating costs avoided, or efficiencies achieved, etc? If so, please elaborate. _____

6. General Comments. What do you think should be changed to improve future reports? (Indicate changes to organization, technical content, format, etc.) _____

CURRENT
ADDRESS

Organization

Name

Street or P.O. Box No.

City, State, Zip Code

7. If indicating a Change of Address or Address Correction, please provide the Current or Correct address above and the Old or Incorrect address below.

OLD
ADDRESS

Organization

Name

Street or P.O. Box No.

City, State, Zip Code

(Remove this sheet, fold as indicated, tape closed, and mail.)
(DO NOT STAPLE)

DEPARTMENT OF THE ARMY

OFFICIAL BUSINESS

BUSINESS REPLY MAIL
FIRST CLASS PERMIT NO 0001,APG,MD

POSTAGE WILL BE PAID BY ADDRESSEE

DIRECTOR
U.S. ARMY RESEARCH LABORATORY
ATTN: AMSRL-WT-PA
ABERDEEN PROVING GROUND, MD 21005-5066

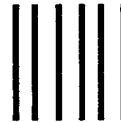

NO POSTAGE
NECESSARY
IF MAILED
IN THE
UNITED STATES

