



AFIT-LA-TR-96-1

AIR FORCE INSTITUTE OF TECHNOLOGY

**AIR FORCE INSTITUTE OF TECHNOLOGY:
ANALYSIS OF INFORMATION NEEDS
AND CAPABILITIES**

Associate Professor Alan Heminger
(and list of students on page 1)

MARCH 1996

DEPARTMENT OF THE AIR FORCE
AIR UNIVERSITY

AIR FORCE INSTITUTE OF TECHNOLOGY

Wright-Patterson Air Force Base, Ohio

DTIC QUALITY INSPECTED 1

AFIT-LA-TR-96-1

AIR FORCE INSTITUTE OF TECHNOLOGY

**AIR FORCE INSTITUTE OF TECHNOLOGY:
ANALYSIS OF INFORMATION NEEDS
AND CAPABILITIES**

Associate Professor Alan Heminger
(and list of students on page 1)

MARCH 1996

19960710 035

Air Force Institute of Technology: Analysis of Information Needs and Capabilities



*Prepared for AFIT/CC by the students of
IMGT651 (Information Systems Analysis and Design)*

13 March 1996

*The views expressed in this article are those of the authors and do not reflect
the official policy or position of the United States Air Force, Department of
Defense, or the US Government*

Alan Heminger, Ph.D.
Associate Professor, IRM

Capt Shari Miles
Team Leader

Executive Summary

The Information Systems Analysis and Design class (IMGT651) was invited to undertake, as a class project, an investigation of problems encountered by people within AFIT that occur when responding to a wide variety of information requests. The investigation of these problems identified a number of shortcomings in AFIT's management of information that underlie and cause these problems. These shortcomings include:

1. Lack of knowledge about where information is stored.
2. Lack of knowledge about using the information systems that are available.
3. Difficulty using some of the information systems that are available.
4. Lack of a comprehensive plan for information management within AFIT.
5. Lack of a clear authority for information management policy.
6. Lack of an Executive Information System to support information requests.

Based on these shortcomings, a number of recommendations were developed to address and improve the management and use of information within AFIT. The recommendations are grouped according to the anticipated horizon for implementation: near-term, intermediate-term, and long-term. Although it might seem that attacking the last recommendation (creating an executive information system) first would solve the bulk of the problems, it can not be adequately addressed until the preceding problems are rectified. The specific recommendations are as follows:

Near-Term

1. Identify and assign responsibility for data administration and database administration.
2. Document and provide information on where information is stored.
3. Provide training and documentation on use of existing systems.
4. Complete and Implement policies on database management and configuration control.
5. Design and implement a user-friendly "front-end" application for some existing databases.

Intermediate-Term

1. Integrate and coordinate existing databases.

Long-Term

1. Migrate "stand-alone" information files into the overall framework of an AFIT strategic information management plan.
2. Develop an Executive Information System (EIS) and long-term view of AFIT's information needs.

Table of Contents

Executive Summary	i
List of Figures.....	iii
List of Tables.....	iii
Introduction	1
Project Introduction	1
Objective and Scope	1
Approach.....	3
Investigation.....	4
Findings.....	5
View of Current Architecture (AS-IS).....	5
Internally Supported Data Systems	6
Externally Mandated Data Systems.....	9
Manual Systems	10
Sources of Information Requirements	10
Difficulty Using Existing Systems	11
Procedural Issues.....	12
Discussion.....	14
Finding Information.....	14
Consistency of Information	14
Accountability for Information	15
Integration of Information Systems.....	15
Information Management.....	16
Training to Use AFIT's Information Systems	17
Improved User Interfaces	18
Integration of Current Databases	18
Longer Term Improvements	18
Conclusion	20
Recommendations	21
Near-Term Recommendations	21
Intermediate-Term Recommendations	23
Long-Term Recommendations	23
Other Recommendations.....	24

Appendix 1: AS-IS Architecture

Appendix 2: List of Database Tables

Appendix 3: Glossary of Terms and Acronyms

Appendix 4: Draft Regulations

List of Figures

Figure 1 AFIT Information System Context Diagram for Responding to Information Requests2
Figure 2 AFIT Supported Information Systems7
Figure 3 View of AFITSIS.....8
Figure 4 Information Systems Mandated by Supporting Agencies10
Figure 5 The “TO-BE” Model for AFIT’s Information Systems.....22

List of Tables

Table 1 Application to Office Cross Reference Matrix.....6

Introduction

This systems analysis project was undertaken in response to a request from AFIT/XO to examine AFIT's information systems. The members of the project team are members of the AFIT/LA course IMGT 651, and are under the direction of the class instructor, Dr. Alan Heminger, Associate Professor of Information Resources Management. The team was led by Capt Shari Miles. All of the team members are students in the AFIT/LA GIR (Information Resource Management) program:

1st Lt Heather Adams
Capt David Gaines
Capt Gordon Geison
1st Lt Jeffrey (J.T.) Hennes
Capt Fredrick (Bill) Knaak
Capt Shari Miles

Flt Lt Trevor Plant
Capt Pamela Quintero
Capt Steve Robertson
Capt Lori Rogers
Capt Greg Schechtman
1st Lt David Snoddy

Project Introduction

In December 1995, Lt Col Wayne Stone (AFIT/XO) approached Dr. Alan Heminger (AFIT/LAR) with a project proposal for his IMGT 651 class. The proposed project entailed performing an investigation of problems encountered when responding to various information requests on behalf of the Commandant. Often the information is difficult to locate, particularly in the desired format, and much time is spent looking for it. Further, similar requests often result in inconsistent responses, leading to confusion and additional time spent trying to reconcile the different responses. Frequently, the difference in responses cannot be adequately reconciled.

Objective and Scope

The objective of this project was to provide recommendations to the AFIT Commandant regarding AFIT's information systems and information management practices to help the Commandant respond quickly and accurately to internal management and external advocacy information requests. The scope of this project was constrained in three ways: (1) Limit analysis to processes that satisfy the Commandant's information requests (ad hoc or periodic), (2) Consider only AFIT directorates and schools as information sources, and (3) Exclude day-to-day operations of AFIT directorates and schools unless they have a direct bearing on the Commandant's information needs. The systems analysis and design team also noted that any recommendations would need to

be compatible with Air University (AU) and Air Education and Training Command (AETC) information and system architectures.

In determining the scope of the project, the team realized it must first gain an understanding of AFIT's current information requirements. Doing so required answering questions such as the following: "What kind of information is currently requested, either by internal or external sources? What information is currently stored and maintained? Where is this information stored and maintained? How is it stored and maintained? By whom?" After receiving preliminary answers to these questions, the team scoped its project to address those systems and practices found within AFIT.

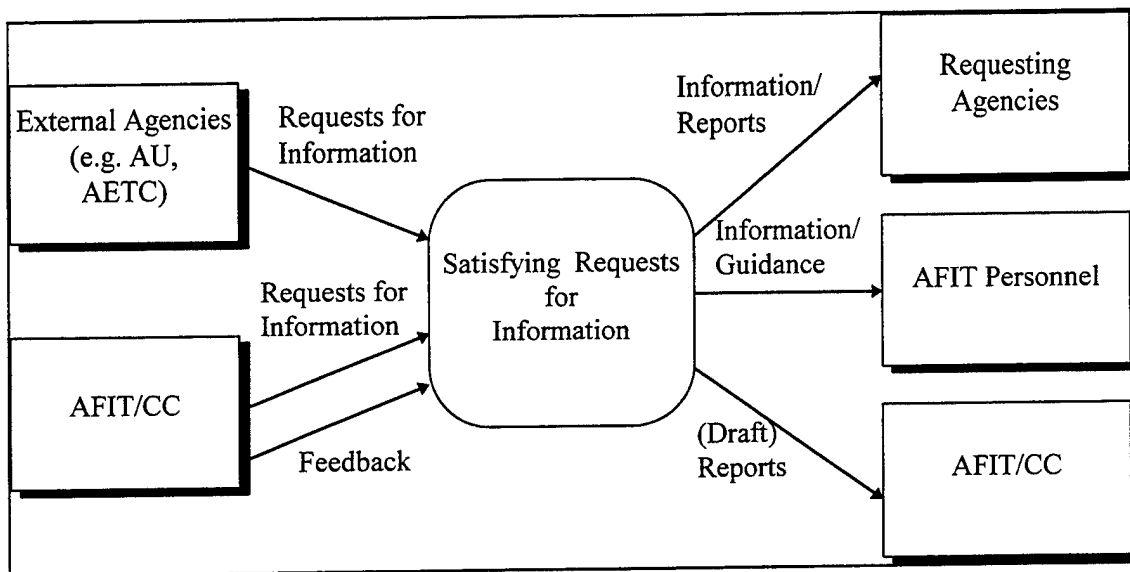

Figure 1 AFIT Information System Context Diagram for Responding to Information Requests

Figure 1 depicts the relationship between AFIT's information systems and various internal and external entities as they relate to satisfying information inquiries on behalf of the Commandant. At different times, the Commandant may request information, provide feedback on reports generated, or be the recipient of reports generated by the staff. The analysis team focused its efforts on those systems and practices falling within the "Satisfying Requests for Information" box shown in Figure 1. Therefore, systems existing at AU or at AETC are defined as being outside the bounds of this analysis project.

Without a good understanding of the systems and resources already available within AFIT, the team could not make an informed recommendation to the Commandant -- it was imperative that the team first understand the information architecture within AFIT. The team, thus, began by exploring the underlying information architecture within AFIT.

Approach

This project broadly encompassed all of AFIT, therefore, the team recognized that it must contact members of AFIT who were involved with the information needs of the Commandant. Theoretically, this could include every member of the faculty and staff at AFIT. The team recognized the importance of gaining the required information, but given the time constraints involved, the most practical approach was to rely on knowledgeable points of contact (POCs) provided by Lt Col Stone. These POCs represented each school and directorate within AFIT. Others would later be contacted as the project progressed and the need arose.

The team considered several possible techniques for gathering information from the POCs and decided that the most appropriate was likely to be personal interviews. Other techniques considered included surveys and questionnaires, group brainstorming sessions and use of a Group Decision Support System (electronic group tool). This last technique was employed for one interview session, and for several of the project team working sessions, and proved to be an effective tool. Surveys and questionnaires were considered to be inappropriate during this initial stage of the project.

Having decided on interviews as the primary means of data collection, the team prepared a series of questions designed to draw the appropriate information from each interviewee, and developed a standard procedure for conducting the interviews and debriefs. The project team was then divided into teams of two and each team was assigned a list of interviewees from the list of POCs provided by Lt Col Stone.

Investigation

The first formal interview was conducted with Lt Col Stone with the dual aims of testing the interview instrument and procedure and obtaining an overview of the organizational environment from the point of view of XO. This initial interview was successful in achieving both aims and signaled the go ahead for the other interviews.

In brief, the interviews were designed to encourage the interviewees to discuss their involvement with the information process in general terms. This open-ended question was used to initiate the interview and to encourage the interviewee to speak freely. The interview then progressed to more specific questions to focus on information of interest to the team. Examples of follow-up questions included targeting types of information provided to the command section, learning where the information was stored, how it was gathered, and how it was finally presented. By gathering this information in face-to-face interviews, the team was able to gain an understanding of AFIT's information processes and obtain copies of information products being prepared on a regular and ad hoc basis. The team was also able to identify some of the manual information stores and databases contained within AFIT.

Upon completion of each interview, an interview report was prepared and returned to the interviewee for coordination and approval. The finalized interview report was forwarded to the rest of the project team members and copies of any information products were provided to the analysis team members.

Findings

Upon completion of the interviews, the analysis team compiled and reconciled the assorted information, data flows, and process diagrams. The team was specifically interested in identifying existing information processes and data stores used in satisfying those processes. The team used this information to construct a view of AFIT's current information systems and then compiled lists of internally supported and externally mandated data systems. These systems represented both manual and automated information systems. We then performed a detailed analysis of this information to draw conclusions regarding the diverse information challenges presented by AFIT's current information systems and information management practices.

It should be noted that the concerns raised while examining AFIT's information systems and information management practices are fairly typical of those found in many large, contemporary organizations. The tremendous strides in information technology have resulted in an information explosion, which affect almost all organizations of any size and complexity.

View of Current Architecture (AS-IS)

The investigative process identified many information systems within AFIT: some manual, some automated, and many semi-automated. The size and complexity of AFIT's operations has led to the development of many unrelated and independent views of data vital to AFIT's operations. During the team's exploration it has focused on those systems that are used as information sources for the Commandant.

In reviewing these systems and determining how best to present the data, we found the most appropriate way to represent the organization of these interrelated systems was to provide a graphical representation in two parts: systems internal to AFIT and systems mandated by external organizations. This representation has been arranged in a topological map in Figures 2 and 4, with the intent of giving an overview of the computing environment at AFIT. Further explanation is provided in Table 1 which contains a matrix view of the systems identified and the offices that use those systems. It provides a baseline for identifying those systems that are under-utilized or that have been generated by and for individual offices. The individual systems are described in more detail in Appendix 1, The AS-IS Architecture.

Office Application	C	X	L	E	P	C	M	R	L	L	R	R	C	S	Q	C	R	
	C	O	A	N	A	I	S	P	S	D	D	A	E	C	I	F	R	
AFITSIS												X						X
STARS			X	X														
QUEST																		
MSQ/							X											
MSI																		
ISA		X																X
APS	X		X	X		X			X	X				X				X
ASAS									X				X					
EES																		X
ENDB				X														
ACES																		
FEDS						X		X										
MIFFS						X												
PSM							X											X
IPMS														X				
PROTRAC														X				
ACQMAN										X								
OCQMAN										X								
FORM9DB														X				
CSRddb														X				
PC-III							X					X						
ATLAS												X						
TMS									X									
UMD								X										
DFAS								X										
LS-STUD- INFO									X									

Table 1 Application to Office Cross Reference Matrix

Internally Supported Data Systems

Figure 2 contains a map of those systems created and maintained in-house by AFIT (or AFIT-sponsored contractors). The primary goal of this map is to identify systems and their users, not necessarily provide detailed information on what is stored in them. The picture that the team's investigation formed highlights the need for a review of the information systems that are internal to AFIT.

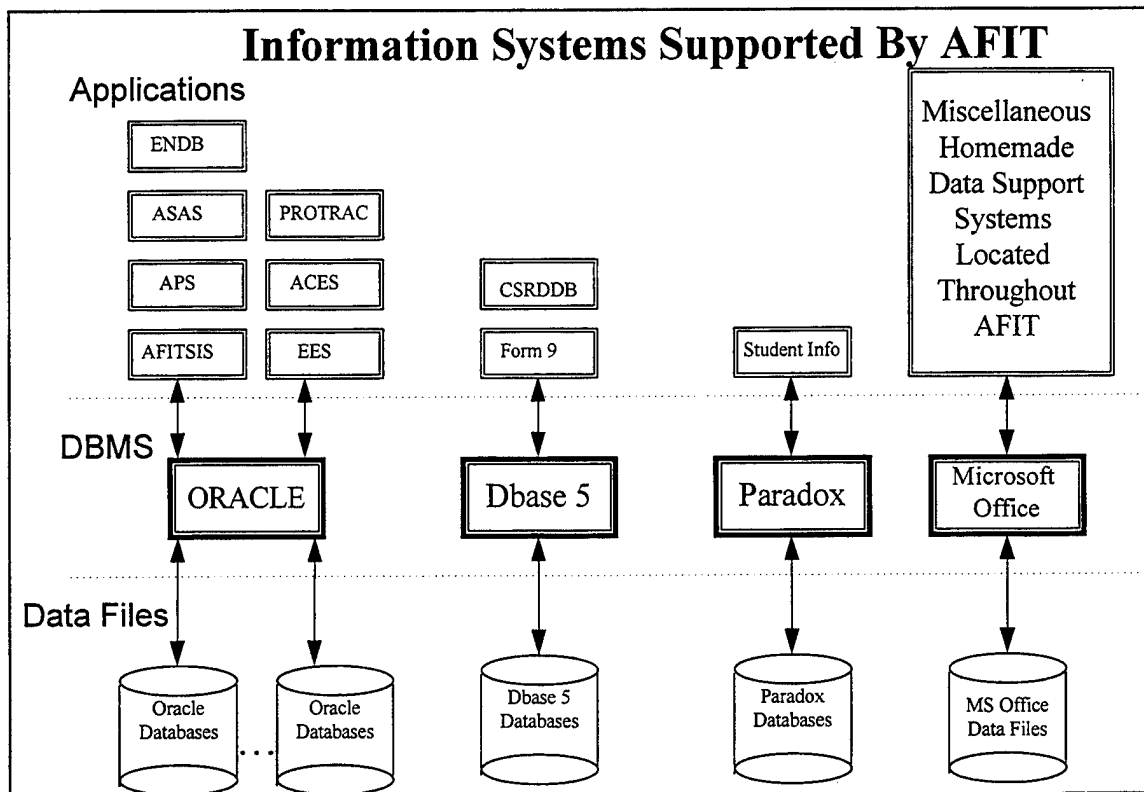

Figure 2 AFIT Supported Information Systems

In general terms, the four largest of the internal information systems are stored in an Oracle relational database system (Figure 3). Other systems store their information through other relational database management systems, such as dBase 5 or Paradox. Still others store their information in non-database environments, such as in Word or Excel files. This is significant because information that is stored in a relational database management system can be stored physically once, then accessed and shared by many applications, each with its own view. The result of this is intended to be a common pool of carefully managed data, with little duplication, and easily created and maintained applications to access it. With the four largest systems accessing a single relational database management system, it should provide the setting for a common pool of carefully managed data. Unfortunately, that did not turn out to be entirely the case. Further digging into the structure of the data in the Oracle database uncovered that there is not a single pool of non-redundant data. Apparently, in many cases, as new applications were added each created its own files of data. This resulted in the same data being stored in more than one place, perhaps called by different data names, and with different data attributes.

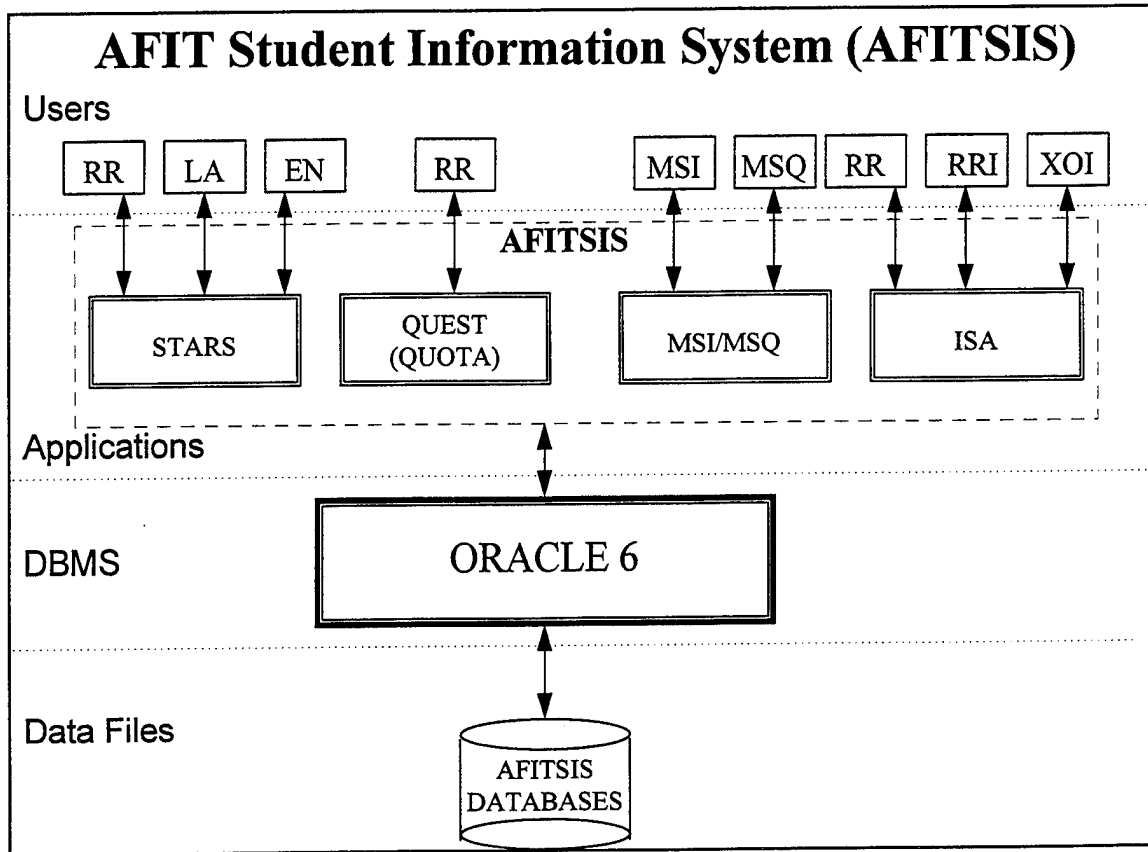

Figure 3 View of AFITSIS

Multiple pools of redundant data are likely to lead to updates and data entries not being made to all of the relevant data. As a simple example, consider a person's address stored in two different data tables. If there is a change of address, and it is only changed in one table, then one can get two different addresses for this person, depending on which table one consults. Even worse, it may not be possible to tell which one is correct, requiring more work to reconcile the discrepancy.

There are several small local-use systems, with little or no database administration support. These systems are often populated with data from information stored in applications such as AFITSIS and AFIT's Civilian Education System (ACES). However, since they may not have reconciliation procedures to ensure consistency with the larger databases, it is likely that they will become inconsistent over time. This may help to explain the difficulty in reconciling disparities between data collected through multiple sources. A prime example of the potential for redundancy is the existence of a registrar style database within LS used for tracking student information. This competes directly with the systems used by RR.

AFITSIS is a conglomeration of four primary applications and utilizes upwards of 250 Oracle relational tables (Figure 3). The team discovered that the component tables of most of the applications contain redundant fields which can result in inconsistent data stores. Because the same item may be called different things in the different applications, it is not possible to be sure that all redundancies are found through casual observation. A detailed analysis of the various tables (beyond the scope of this study) will be necessary to be sure that all redundancies are identified.

STARS is the largest component application of AFITSIS. It contains almost 200 tables by itself, and could potentially satisfy most of the Commandant's information needs, if combined with the Civilian Institution Directorate's ACES.

AFITSIS, however, suffers from a malady that afflicts many of the earlier generation of RDBMS implementations: poor documentation and little training, along with what the users perceive to be a user-surly interface. These perceptions may explain to some extent why alternative systems (such as the registrar replacement in LS) have blossomed in the shadow of the official system. More than one office indicated they could not rely on information being supplied by AFITSIS (STARS), because they themselves were not entering updated information, again because of the interface.

It is the systems analysis and design team's understanding that the user interface issue is being addressed in some form with the migration to Oracle v7 RDBMS which utilizes a graphical user interface (GUI) and easier to use query language. This migration will provide an opportunity to perform a reengineering of the AFIT information environment.

Externally Mandated Data Systems

In addition to internally developed and managed information, AFIT also interacts with outside agencies, such as AU and AETC. These agencies have their own data needs that often require compliance from AFIT. Thus, in addition to developing internal standards, AFIT must support the information system needs of those outside agencies to which it reports. Prime examples of these systems are PC-III and DFAS. These are mainframe based systems and use network connections to allow updates of the information to the host DBMS. There are some PC-based systems that are mandated for standardization of data and management techniques within the Air Force, not just AFIT. Examples of these systems are the ACQMAN and OCQMAN, which are Enable applications used for library financial management.

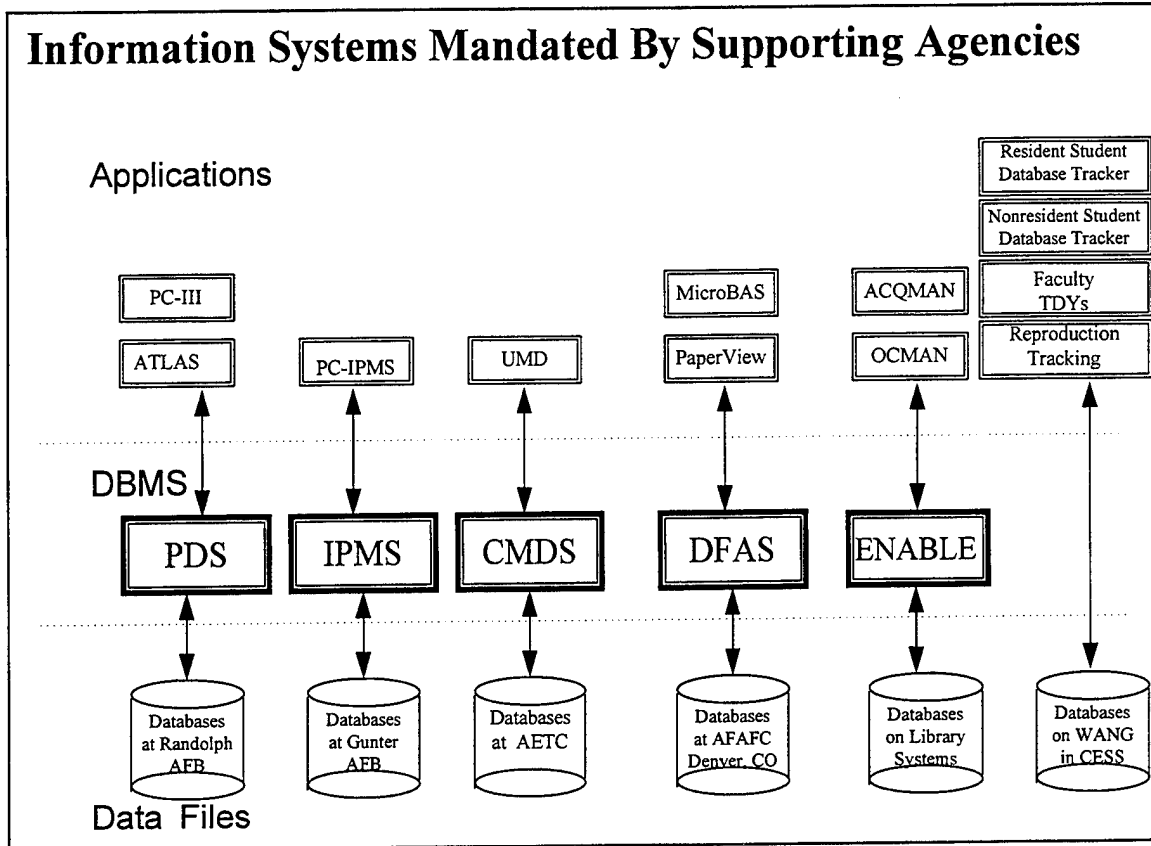

Figure 4 Information Systems Mandated by Supporting Agencies

Manual Systems

In addition to the computerized systems used in AFIT there are many manual or semi-automated processes in each of the offices interviewed. We found in some instances that the reason for several manual systems is a lack of trust in, and reliability of, information maintained in the primary electronic information sources. It was also learned that many people do not know what information is available in the various electronic information systems. These manual systems consist of paper records and electronic files on PCs in (generally) one of the MS Office formats: Word, Excel or Access. These systems are typically the systems used to prepare information for presentation to the Commandant or in response to queries.

Sources of Information Requirements

During an interview, the Commandant expressed a need to access AFIT's aggregate cost and throughput data. The form of this information falls within three broad categories. First, information is needed on student *scholastic characteristics*. This includes such things as GRE scores, attendance and

graduation rates, and the number of student waivers. The Commandant also wants *non-scholastic information*, e.g. student numbers or demographics, research sponsorship, and the details of follow-on assignments. Finally, anything that impacts the *budget process* needs to be readily accessible.

The Commandant's questions are often routed to the schools and directorates to answer due in part to the executive officer's lack of an accessible database. This has led to directorates experiencing difficulty separating information needed to support the Command Section from that used in day-to-day operations. Many of the directorates feel they contribute very little on a continuing basis to the Commandant's information needs. However, there was a feeling that many ad hoc reports indirectly benefit the Commandant. For instance, CI stated, "We do quite a few ad hoc reports for CC through XO ... Many of the ad hoc questions are very short notice requests for information that simply is not available."

Ad hoc queries have had a significant impact on AFIT's information needs. The directorates are forced to respond to inquiries from Air Staff, AU, and various MAJCOMs. Many of these have short suspenses and are negatively affected by the lack of a coordinated database. CE provides an example of this. They have no automated rosters or transcripts. All queries are done by manually checking papers in a file cabinet. SC (in providing information for the financial plan) and XO (for information not in STARS) relayed similar examples. The Commandant acknowledges this is a problem: some questions are not asked simply because it would require too much manpower to provide answers. This is symptomatic of problems with the existing systems.

Difficulty Using Existing Systems

AFIT personnel have difficulty using the existing information systems to maintain, manipulate, and retrieve essential data. The lack of a unified, coordinated data model and the lack of education and training to use the systems are two major impediments.

Our research has indicated that many AFIT personnel have difficulty in finding needed information in the existing information systems. This difficulty in locating needed information has led people to create individual data stores in order to meet day-to-day information needs. Some of these data stores include manual filing systems, others include extracting information out of an existing system (such as STARS) and entering the data into a spreadsheet (such as EXCEL) in order to manipulate the data and generate the necessary reports. These individual practices have caused data duplication, data inconsistencies, and a lack of confidence in the reliability of the information. Furthermore, many

offices routinely spend an inordinate amount of time searching for information because they do not know it is readily available in an existing AFIT system.

Lack of education and training is another reason AFIT personnel have difficulties using existing information systems. Many individuals have not been trained on how to use the current systems to meet their information needs. Further, most people do not know what types of data the databases contain or how to access that data. Moreover, instruction manuals seem to be in short supply. Of the few individuals who could access the data, virtually all claim that the user-interface is difficult to use. In general, most individuals have not had training on the systems and do not know who to consult for support. This is especially troublesome since AFIT personnel must respond quickly to numerous requests for information on a daily basis.

Procedural Issues

In addition to problems using the existing systems, many problems arise from the existing procedures for getting information. Many ad hoc requests are received and because they are ad hoc, there is no particular tracking system for this type of information as there would be for periodic reports. In addition, some of these ad hoc requests are repeated so it would be helpful to keep a file or database of some sort that could be searched if similar information is requested again. One office did keep a notebook of previous answers to ad hoc requests. A potential problem with adopting this approach, however, is that it may be hard to keep the log updated.

There are also problems with poor wording of requests or conflicting definitions of words within the requests. Many offices are not sure what information is being asked for because there could be many ways of interpreting the request. A simple example is a request for the number of students at AFIT. To some offices this would include international students whereas to others it would not. Some say the number of students is the quota eventually reached but some say it is the number of students in the actual seats at AFIT. Also, if requests are filtered down to many different offices, the details of the request may eventually be filtered out and the person who is filling the request ends up providing insufficient or unnecessary information. Filtering requests down to other offices can also result in diminishing priority. A person that is asked to get information regarding the request may not see it as top priority while the person waiting to answer the request may feel it is of very high priority, depending on where the request is coming from and how soon it is to be answered.

Another area of concern is the keeping of records regarding student research and transitions. Records need to be kept on student throughput and on-time graduates for the civilian and military schools. For example, no records

are kept in reference to who the receiving commands of the students are and what theses or dissertations were completed by which students. The questions are: What kind of information needs to be tracked and who should track that information? Value added needs to be considered when tracking certain information. For example, the following questions should be asked when deciding whether or not to maintain a particular piece of information; "Does tracking this information add value to my job or tasks? Is it worthwhile to have this information and to have this information updated?"

Discussion

Finding Information

During the team's examination of AFIT's information management, the individuals we spoke with from across AFIT regularly emphasized three crucial problems with the structure of data at AFIT. First, virtually every work center recognized that there was no single definitive source of information that covers the whole range of processes supported by AFIT. Information is maintained in fragmented and isolated packets that often serve the particular narrow needs of an individual work center, but cannot be made easily available to those outside that center. The problem arising from this situation is that information crucial to senior leadership is often hidden behind a confusing array of disparate storage methods.

A lot of the information identified as needed was discovered to exist in some database or other form but the requester does not know whom to ask or what office is responsible for maintaining the data. Many times individuals do not believe the information needed or requested is currently being captured, when in fact the information is available but in a form or location unknown to those with a genuine need to know. An example of the need for this education can be recognized by the following scenario. Once a year, surveys are received from the Council of Graduate Schools, National Science Foundation, and Integrated Post Secondary Data System. In an effort to gather the data for these surveys, a request was sent to RR to supply data on the number of students by gender and ethnic background. RR does not track gender and ethnic background so a manual search through all student records was performed to gather the data. This information could have been gathered through PC-III. The personnel systems manager (PSM), could have easily written a query to pull this information from the Personnel Data System (PDS). An overall systems model detailing data sources and responsibility would be beneficial.

Consistency of Information

Multiple sources of information (often covering overlapping categories) mean that there will inevitably be inconsistencies in the data that is retrieved from these non-integrated and non-coordinated databases. Information is updated at different times, in different ways, and for different purposes. When a record is updated in one database, similar information contained in a separate database is immediately rendered inconsistent. Unless there is automatic, seamless communication between the various data sources, inconsistencies are unavoidable. Each data source also has elements of information defined in unique ways that may not correspond to the data definition contained in other information sources. For example, a question that seems as clear as "How

many students are assigned to AFIT?" might get a range of answers from 400 to 4,000 depending on exactly what one means by assigned to AFIT. The problem is compounded by asking for more specific information which requires further interpretation, such as specifying a year. For example, does the requester mean fiscal year, calendar year, or academic year? Asking three different offices the "same" question can lead to three different answers because the question may not, in fact, mean precisely the same thing to each of those offices. Subtle distinctions in meaning (often not appreciated by those requesting the information) can lead to significant discrepancies between what the requester intended and what the action office understood. Standard definitions of crucial data elements would help alleviate miscommunication and clarify information requests.

Accountability for Information

The splintering of information into widely scattered databases leads to a diffusion of accountability. Work centers too often focus on their individual concerns without a holistic appreciation for how their information fits into the overall data structure. This leads to the perception that AFIT's corporate information resources do not belong to anyone in particular. Therefore, no one is identified as the responsible party for ensuring the uniformity, currency, and accuracy of the vast array of information that is captured daily throughout the Institute. This dilution of accountability undermines the critical sense of ownership that inspires vigilant attention to detail and accurate, timely updates of information. In conjunction with consolidating and integrating databases, clear lines of responsibility also need to be established that define who owns the information.

Integration of Information Systems

The AFIT managerial staff recognized the need to improve the management of information within AFIT. The current systems are diverse and poorly integrated. Efforts to better integrate the systems have been incomplete and therefore, often unsuccessful. The result is that AFIT has a variety of disparate information systems, some of which do not "talk" to each other, and others of which are hard to use. Furthermore, the information contained in AFIT's information systems is often redundant, inconsistent, or simply hard to find.

For example, when the Commandant receives a request for information, members of his staff respond to produce a report, briefing, or other suitable response to the request. Ideally, the information would be pulled from one or a few of the automated databases, along with some information from manual systems. Unfortunately, that is not what usually happens. All too often, the

information can not be found in an automated system, and much time is spent searching through manual sources. Further, it is often not clear where to look for information, so much time can be lost simply trying to identify an appropriate source. To further compound the problem, the information may be stored in multiple locations. When this happens, updates often are done on only one source, leading to "update anomalies". The information is inconsistent, which can lead to inconsistent results, depending on which source is used. There is currently no simple way to produce needed information quickly and accurately. Additionally, because there is no standardized procedure to collect and disseminate information, follow-on reports may also produce inconsistent results.

Information Management

Information management entails two key responsibilities, both of which must be addressed to ensure proper use of AFIT's information resources. The first of these is data administration. Data administration involves the responsibility for development and implementation of the overall plan for collecting, storing, and using AFIT's information. It is predicated on the understanding that information is a crucial organizational resource, and as such, plans for its use must be developed in a context of overall organizational needs. For instance, data administration involves decisions about what information to collect and store, as well as who should be able to read, write, and modify it. In a modern information system, in which information is stored physically once, and used by many sub-units of the organization, these decisions become very important. They should be made with managerial needs in mind, and should be based on the AFIT information management plan. Only through this top-down view of information management can problems such as data duplication and data inconsistency be controlled, and access to needed information in a timely manner be ensured.

The second key responsibility is database administration. Although this sounds at first like data administration, database administration is a more technical responsibility involving the proper management of AFIT's various computerized database management systems. Physical design of the actual data files is managed at this level, as well as *implementation* of information management policy, such as the actual assignment of rights to read, write, and modify data to the appropriate people. While there are people assigned responsibilities for database administration within AFIT, there appears to be room for improvement in the focus and comprehensiveness of the assigned responsibilities.

The team learned that policy directives were being drafted in 1994 by Barb Cerny to manage AFIT's information systems. Ms Cerny, however, no longer works at AFIT and no one has taken over the completion of these responsibilities since she departed. These directives should be finished and implemented as

operating instructions or directives to guide AFIT's information resources and existing systems in the correct direction. As a start, there should be at least two directives written for AFIT. The first should be a policy on maintaining AFIT's databases and the other should direct the establishment of a configuration control board. The implementation of these policies would ensure AFIT's information systems have a specific office of responsibility and would also eliminate problems associated with the maintenance and redundancy of data. Currently, there is no specific person or office to make clear policy regarding AFIT's information needs. The responsibility for this would logically belong to the assigned data administrator.

The data administration and database administration responsibilities, along with the database management and configuration control policies, are typically components of an Information Management Strategic Plan. This plan is linked to an organization's strategic plan and provides a scheme for managing information used in business operations, and identifies the roles and responsibilities of staff within the organization. The presence of this plan would allow AFIT to identify opportunities for integration of existing data stores and information systems.

Training to Use AFIT's Information Systems

Training on use of existing systems and documentation for the use of applications would be beneficial for most individuals using AFITSIS. Analysis of the interviews has led the team to the conclusion that (1) the majority of people within AFIT do not know how to use the existing systems, and (2) without a process to train these individuals, AFIT will find itself in this same position into the foreseeable future. It was mentioned in several interviews that the systems within AFIT are difficult to access and the team has since discovered that individuals have created their own systems to store and maintain the data they need. This is due in part to the individuals not knowing how to use the systems they have, indicating a definite lack of training. The training program should include: (1) catch-up training and (2) ongoing training. Initially, training should be provided to bring the individuals who have an immediate requirement to access data up to speed on the systems that currently exist within AFIT. This training should provide instruction for using query languages and should also provide written documentation for various applications. Ongoing training is needed to ensure that AFIT staff stay proficient in using the systems as upgrades and modifications to the software and systems occur and as new employees come aboard.

Improved User Interfaces

Historically, creating applications would be a mid- to long-term recommendation. In this case, however, the team believes it may be possible to quickly create new user interfaces to allow simple access to the existing information. The team recommends identifying key areas such as STARS, ACES, and ASAS to begin with, since these applications are the most widely used. There are several software applications that exist internally to AFIT which could be used for this purpose. They include: Database Reporting with Impromptu, Oracle Reports, and Microsoft Access. AFIT SC personnel recommend using Microsoft Access because of its capabilities to generate reports and perform queries. Moreover, Microsoft Access works in a windows environment and has on-line help procedures to assist users. For those individuals who will be working with Microsoft Access to generate reports and perform queries, there is a 3-day training course offered through the Wright-Patterson Campus, which is free.

Integration of Current Databases

The storage of data within AFIT is fragmented and disjointed, resulting in rampant data redundancy and inconsistencies. This problem can be addressed by integrating and coordinating the databases. The first step toward this integration involves thoroughly mapping the tables and contents of all the current databases. The team has created an "AS-IS" architectural model to be used as a baseline for improvements (Appendix 1). A well-defined architecture would greatly reduce data redundancy and its resultant accuracy problems. The Commandant would have renewed confidence in the information offered in response to his requests. Some of the keys for implementing the single database architecture include: correctly mapping the current tables, the changeover process used, well-defined data definitions for the integrated database, and a well-maintained map of the structure. It is also important to have a person specifically assigned to the integration and be responsible for it as an on-going activity. The responsibilities for this would belong to both the data administrator and the database administrator.

Longer Term Improvements

Migrate "stand-alone" information files into the overall framework of AFIT's information management strategic plan. The result of migrating stand alone information files is intended to create a common pool of managed data, with little duplication, and easier access. The use of query language interfaces to this pool of information will enable the staff to quickly generate reports or temporary tables on which to base documents created previously by a word processing or

spreadsheet application (for example, Word or Excel). Word processing applications are typically used for structuring and presenting data that is retrieved from databases, not to act as a store for data that will be shared and reused. For AFIT to migrate these "stand-alone" files, someone will need to perform a detailed analysis and reconciliation of data contained in existing RDBMSs and data stored in stand-alone files. An additional consideration is that of data which is not currently being maintained electronically but is needed to reply to requests from the Commandant or other agencies. Once the stand-alone files are integrated there will be improved access to data and elimination of redundant sources for information.

Develop an Executive Information System (see "TO-BE" Model in Figure 5). Since an EIS presupposes that the information to be accessed currently exists in a carefully managed system or systems, it is important that AFIT's information systems be up-to-date and accurate. This does not mean AFIT would have to do away with existing information systems. Currently, AFIT has several applications which access several databases with no common interface. In addition, there are several "maverick" systems used within certain work centers that only assist a few individuals. This has caused multiple sources for information, data inconsistency, and splintering of information across several databases. The team recommends adoption of the "TO-BE" model with multiple applications using common interfaces to relational databases with normalized tables.

Conclusion

The analysis of the material gathered in this study leads to a number of conclusions about the use of information and information systems within AFIT.

1. There is frequently a lack of knowledge about where information is stored within AFIT's information systems.
2. Many people do not understand how to use the information systems that are available. There appears to be very little documentation on the existing systems, and they are not very amenable to figuring them out without the documentation. As a result, people find work arounds, which often results in creating a new, off-line information system.
3. There does not appear to be a Information Management Strategic Plan for AFIT. This plan is linked to an organization's strategic plan and provides a scheme for managing information used in business operations, and identifies the roles and responsibilities of staff within the organization. The presence of this plan would allow AFIT to identify opportunities for integration of existing data stores and information systems.
4. All of the problems listed above explain why there is not an executive information system (EIS) at AFIT to assist managers in responding to information requests. An EIS is an information system that draws its information from the organization's other information systems. In their current state, they cannot dependably support an EIS. To create a useful EIS, it will first be necessary to address the problems with the overall management of AFIT's information.

Recommendations

The AFIT Commandant recognizes a need to improve information management within his organization. The problems AFIT is experiencing occur in many organizations, within both the military and private industry. These problems are exacerbated by the growing complexity of modern organization and the increasing information needed to manage them. At the same time, rapidly evolving information technology increases our capability to manage that information.

AFIT also has a responsibility to develop an architecture that facilitates open access to information all the way up through DoD. Furthermore, in accordance with DoD's Technical Architecture Framework for Information Management (TAFIM), all information systems and architectures will be developed in a framework that allows for this open access to information that is compatible throughout DoD. AFIT should not only look down within its organization but also up to those organizations to which they report, AU and AETC, to develop systems consonant with theirs.

With the foregoing in mind, and based on our analysis, we have developed a set of recommendations. They will be addressed as near-, intermediate-, and long-term recommendations. We feel that these recommendations will result in improved productivity and quicker data retrieval, along with greater information accuracy and much more efficient and effective information systems in general. As each of the following recommendations is implemented, AFIT will move one step closer to a more integrated and coordinated management of its information. It will facilitate a better way to respond to AFIT's information needs. The following are our recommendations:

Near-Term Recommendations

1. Develop an Information Management Strategic Plan.

a. Identify and assign responsibilities for data administration and database administration.

Progress towards a more coherent management of AFIT's information is dependent on the appointment of a data administrator and database administrator to fulfill the responsibilities identified in the "TO-BE" information architecture model in Figure 5.

The first of these is data administration. Data administration involves the responsibility for development and implementation of the overall plan for collecting, storing, and using AFIT's information.

The second key responsibility is database administration. Although this

sounds at first like data administration, database administration is a more technical responsibility involving the proper management of AFIT's various computerized database management systems. Physical design of the actual data files is managed at this level, as well as *implementation* of information management policy.

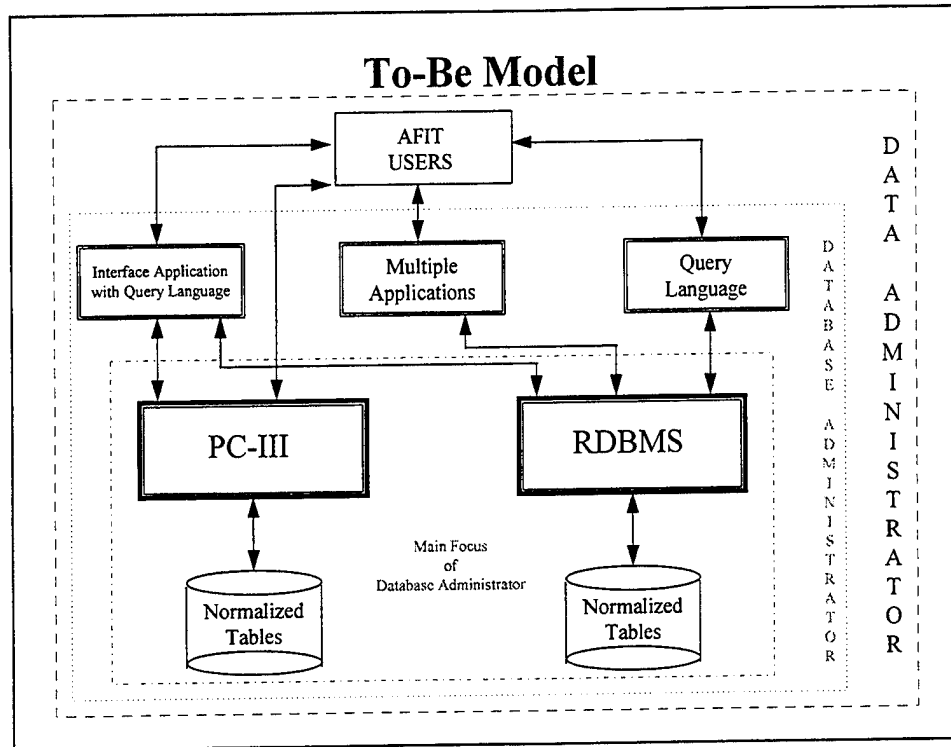

Figure 5 The "TO-BE" Model for AFIT's Information Systems

b. Document and provide information on where information is stored.

A lot of the information identified as needed was discovered to exist in some database or other form but the requester does not know whom to ask or what office is responsible for maintaining the data. As part of this report, the team has provided "AS-IS" models of AFIT's data flows in Appendix 1 and an explanation of the database tables in Appendix 2.

c. Complete and implement database management and configuration control policies.

Two directives in particular need to be written for AFIT. The first should be a policy on maintaining AFIT's databases and the other should direct the establishment of a configuration control board. The implementation of these policies would ensure AFIT's information systems have a specific office of responsibility and would also eliminate problems associated with the maintenance and redundancy of data.

2. Provide training on use of existing information systems.

Training on use of existing systems and documentation for the use of applications would be beneficial for most individuals using existing AFIT systems. The training program should include: (1) catch-up training and (2) ongoing training.

3. Design and implement a user-friendly “front-end” application to get information from existing databases.

Historically, creating applications such as these would be a mid- to long-term recommendation. In this case, however, the team believes the customization and use of particular applications within AFIT would be productive in the near-term.

Intermediate-Term Recommendations**4. Integrate and Coordinate Existing Databases.**

The storage of data within AFIT is fragmented and disjointed, resulting in rampant data redundancy and inconsistencies. This problem can be addressed by integrating and coordinating the databases. The first step toward this integration involves thoroughly mapping the tables and contents of all the current databases. The team has created an “AS-IS” architectural model to be used as a baseline for improvements (Appendix 1).

Long-Term Recommendations**5. Migrate “stand-alone” information files into the overall framework of AFIT’s information management strategic plan.**

The result of the migration is intended to be a common pool of managed data, with little duplication, and easier access. The use of query language interfaces to this pool of information will enable the staff to quickly generate reports or temporary tables on which to base documents created previously by a word processing or spreadsheet application (for example, Word or Excel).

6. Develop an Executive Information System.

Since an EIS presupposes that the information to be accessed currently exists in a carefully managed system or systems, it is important that AFIT’s information systems be up-to-date and accurate. The team recommends adoption of the “TO-BE” model with multiple applications using common interfaces to relational databases with normalized tables.

Other Recommendations

The systems analysis and design team has been asked what it can contribute to helping AFIT achieve the recommendations addressed in this report. In the area of training and education, the team can provide background information gathered and facilitate the AFIT personnel assigned to the training and education task.

The team can assist in establishing guidelines for the draft operating instructions or directives. Regarding the phased approach for front-end applications, the team can assist with systems analysis and design and perhaps in prototyping new front ends for some applications.

The team could also assist with the design and integration of any data models required as AFIT models its architecture. Moreover, the team could provide some direction and guidance from the focal point of individuals who have gathered the data for the "AS-IS" model. The team could also assist in developing guidelines for the responsibilities of data administrator and database administrator. Lastly, the team could also assist in developing requirements or other information necessary for the EIS project.

We urge the Commandant to implement the near-term recommendations as quickly as possible to improve the productivity and efficiency of AFIT's management of information. The intermediate and long-term recommendations should be included in AFIT's future plans to provide maximum opportunity for completion of the tasks.

We would like to thank the AFIT faculty and staff for their time and for providing the necessary inputs to complete our report.

APPENDIX 1

(See accompanying Microsoft PowerPoint 4 file
AP-MODEL.PPT
for Appendix 1 to the report)

Information Systems Supported By AFIT

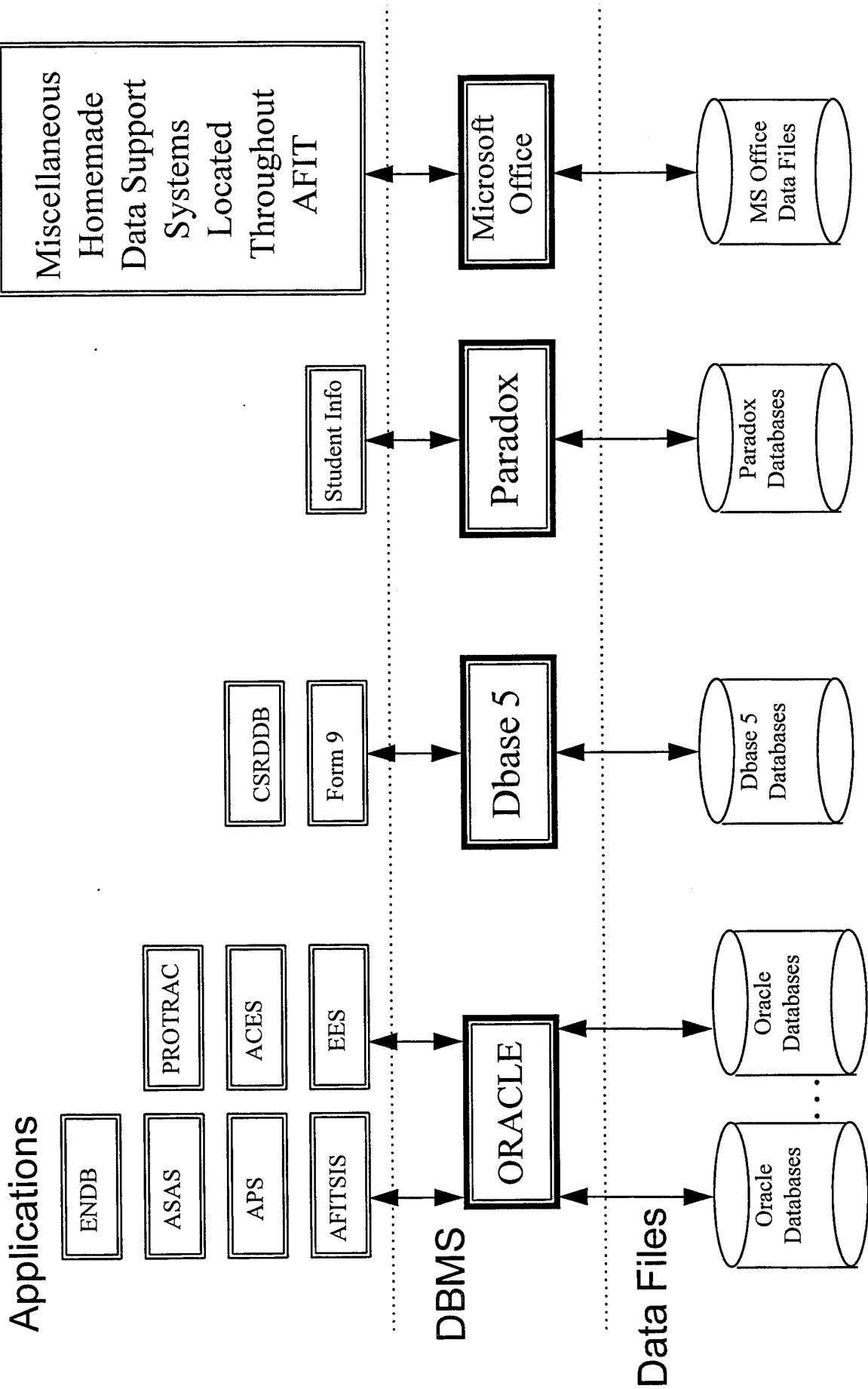

Information Systems Mandated By Supporting Agencies

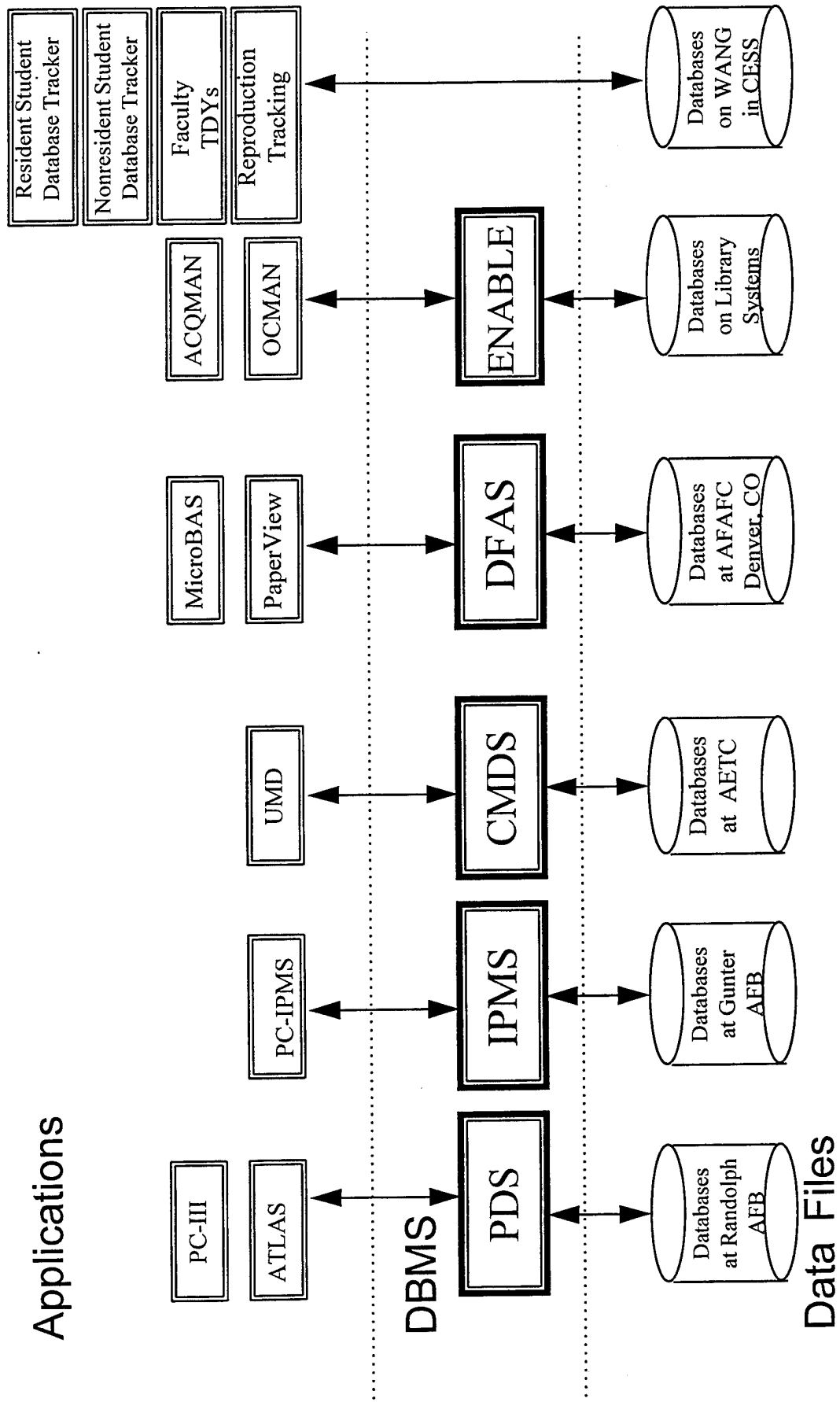

AFIT Student Information System (AFITSIS)

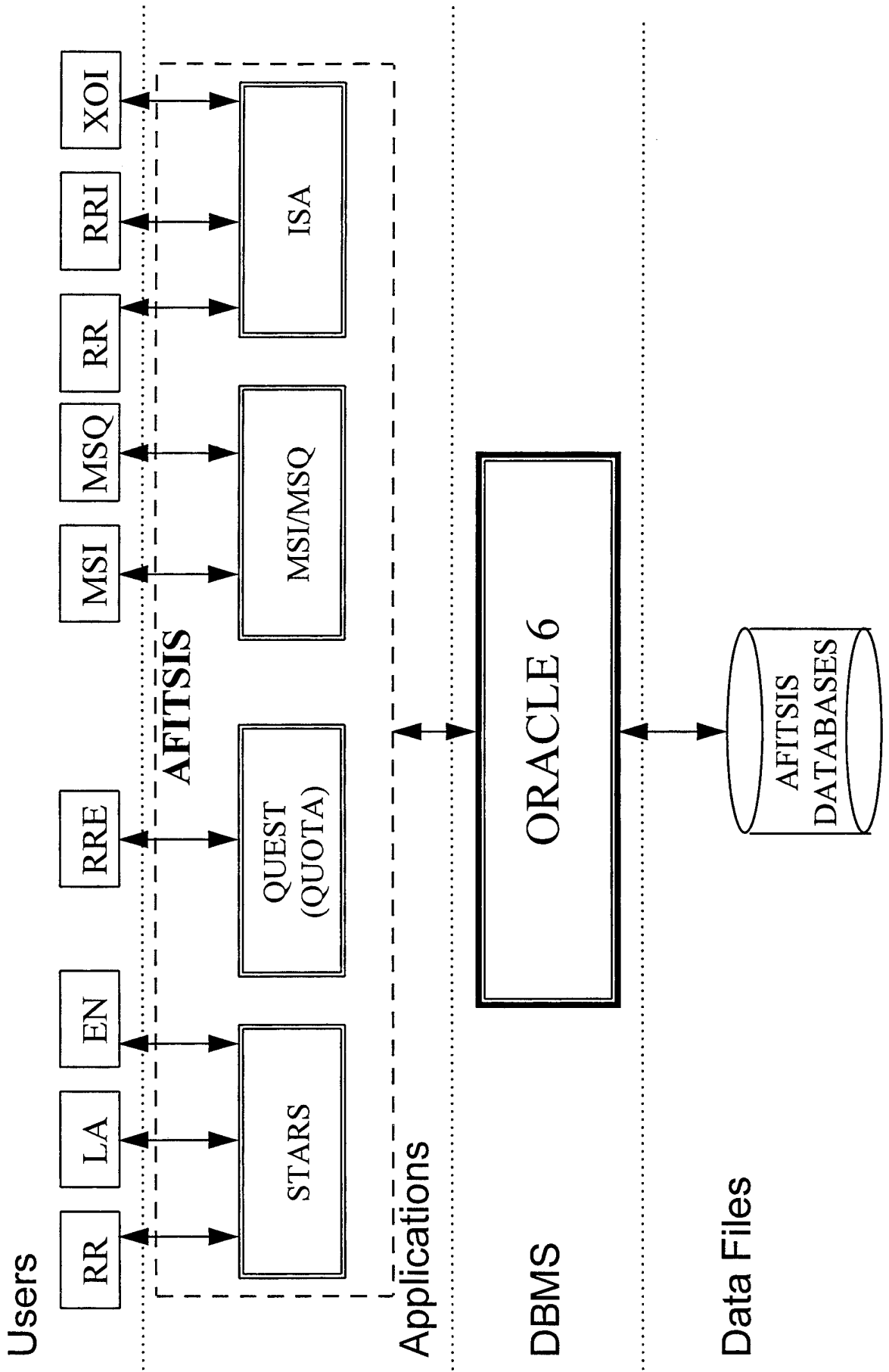

AFIT Personnel Management System (APS)

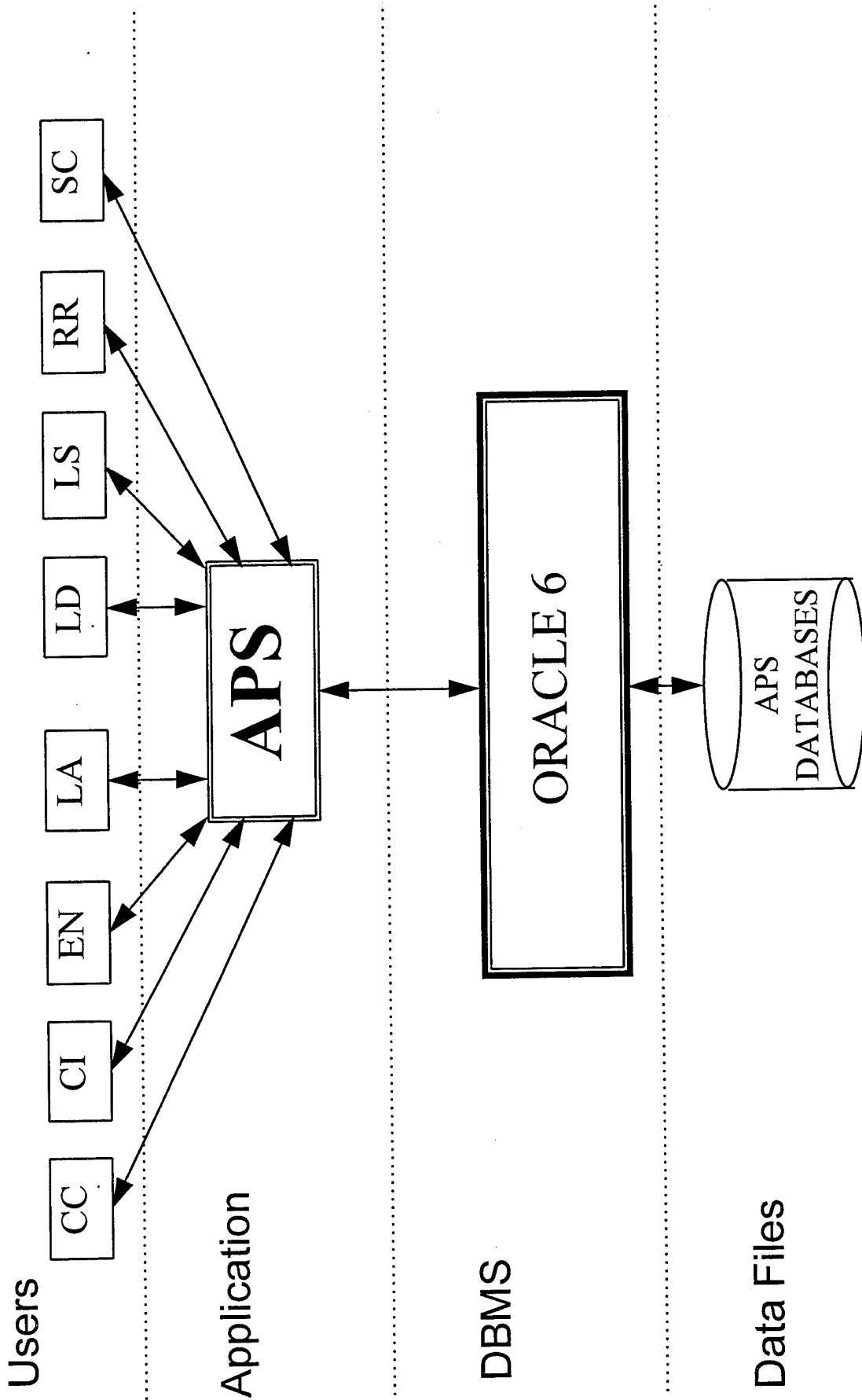

Automated Space Allocation System (ASAS)

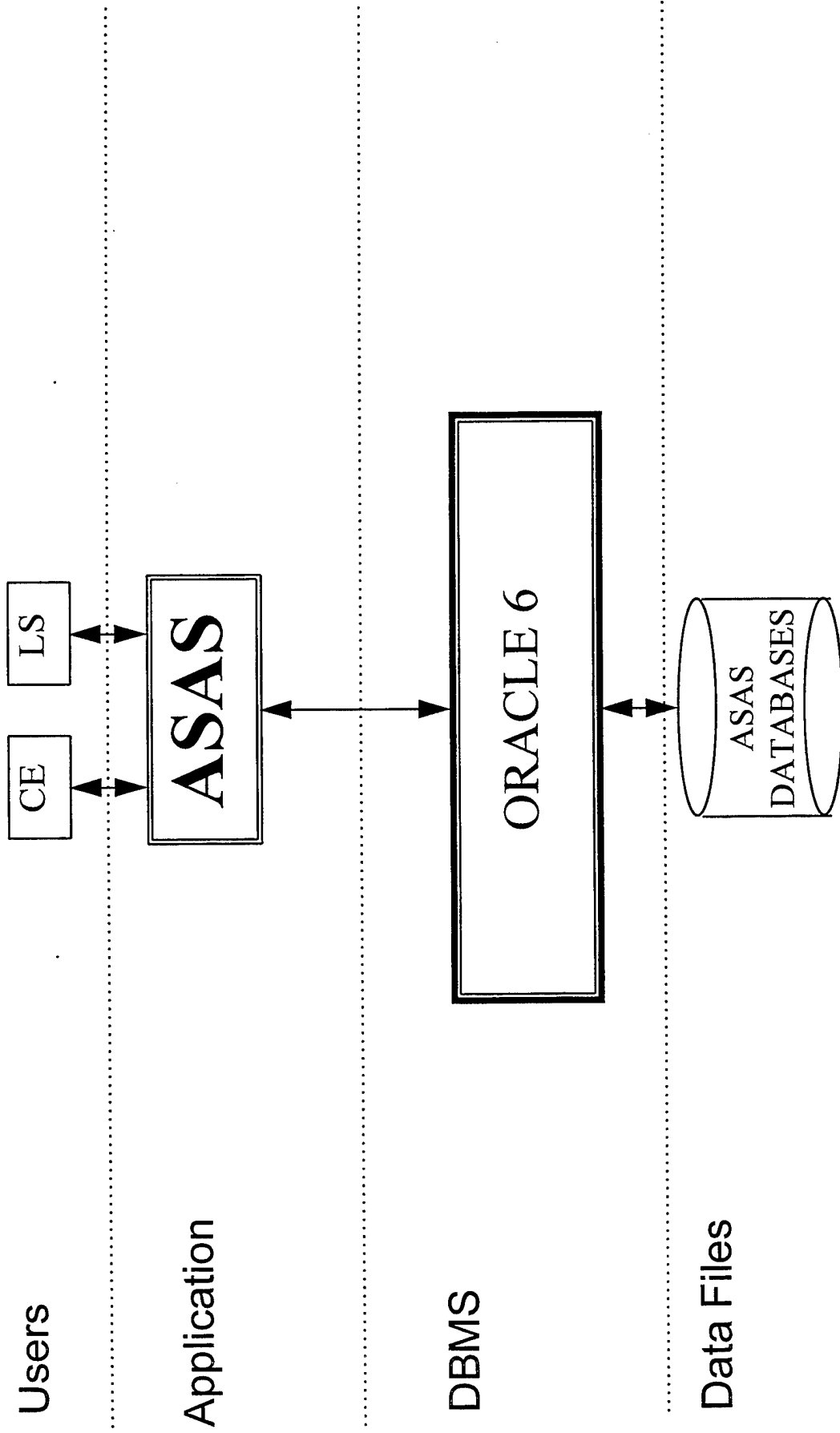

Equivalency Exam System (EES)

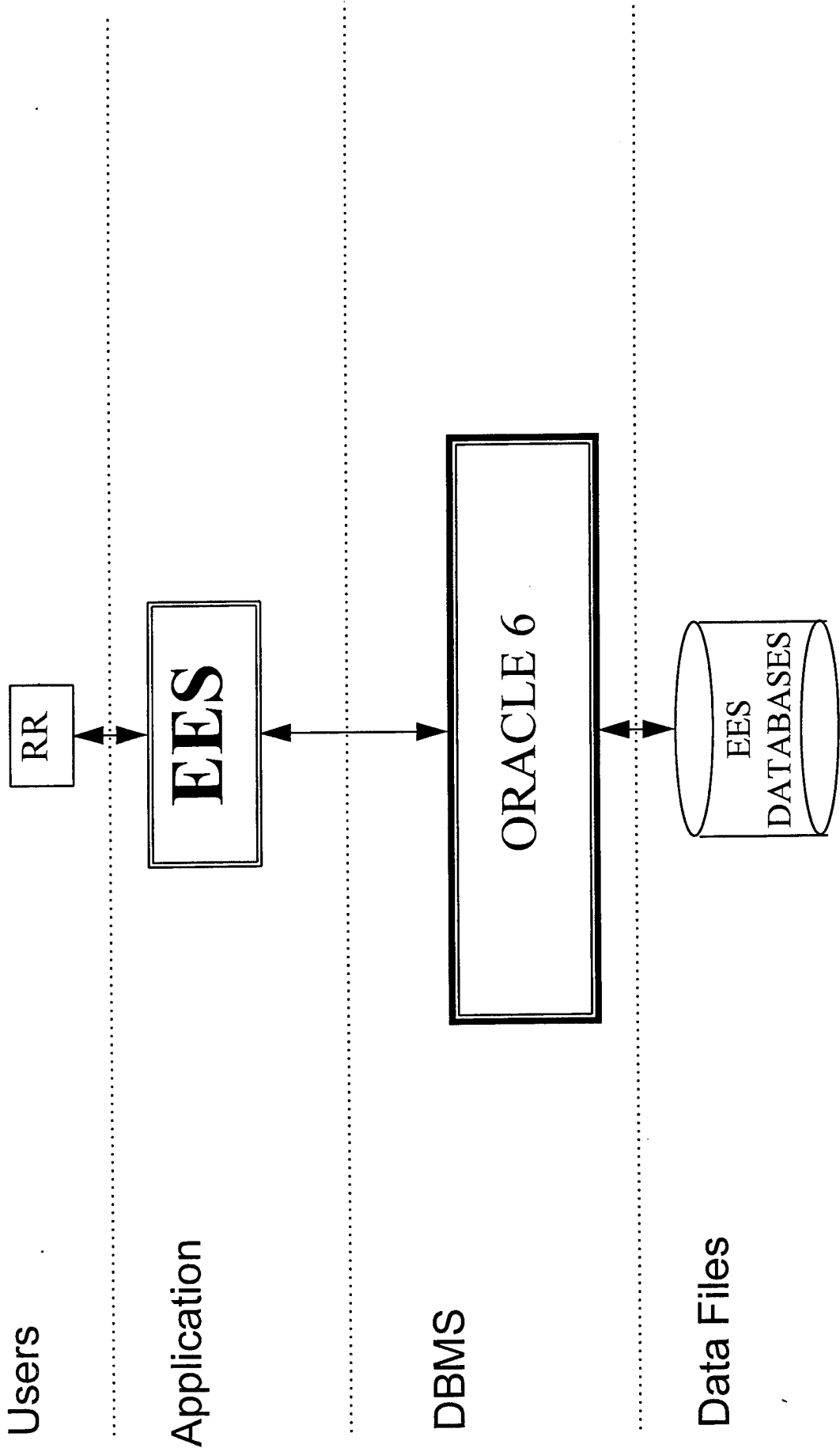

AFIT/EN Database Applications (ENDB)

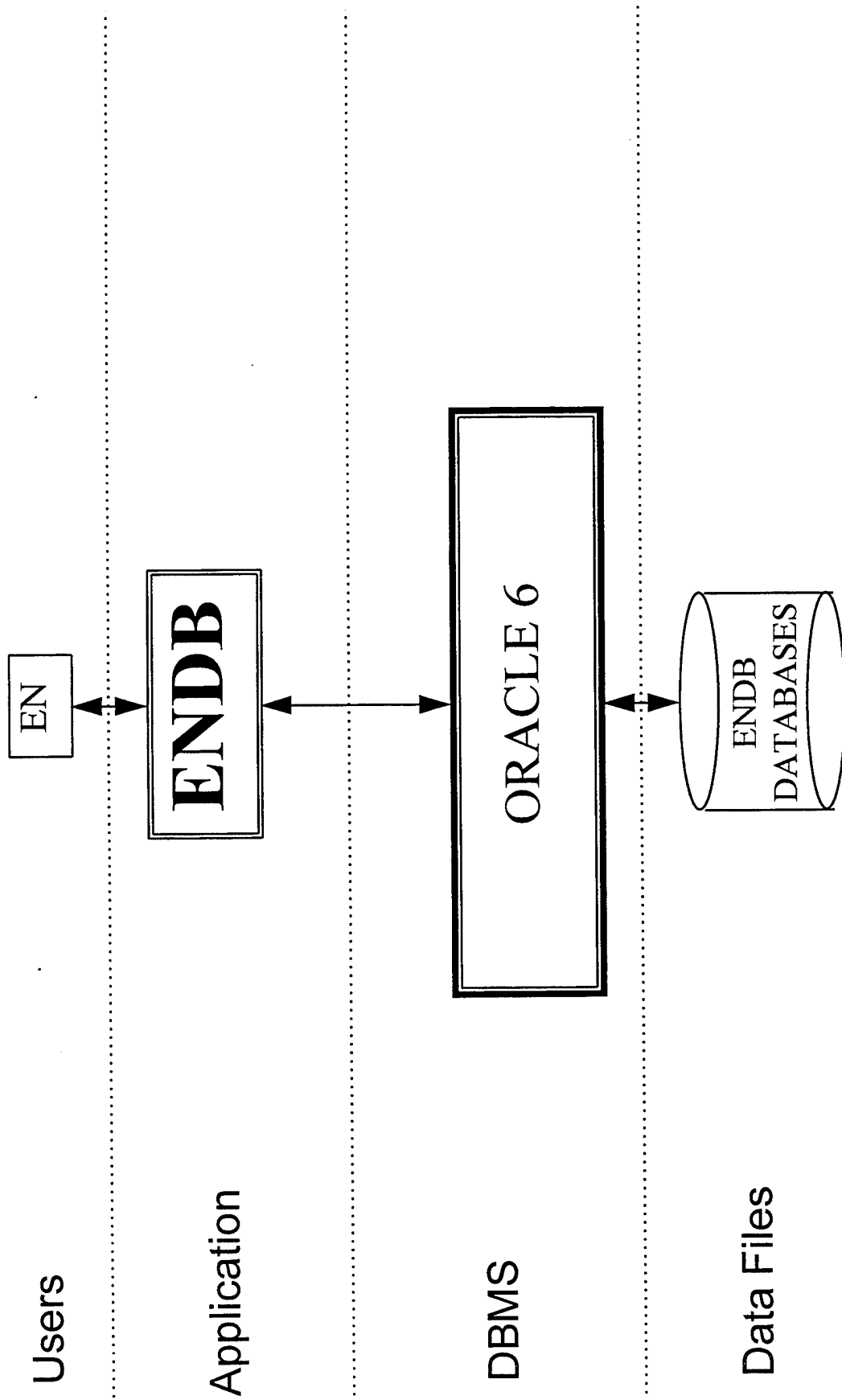

AFIT's Civilian Education System (ACES)

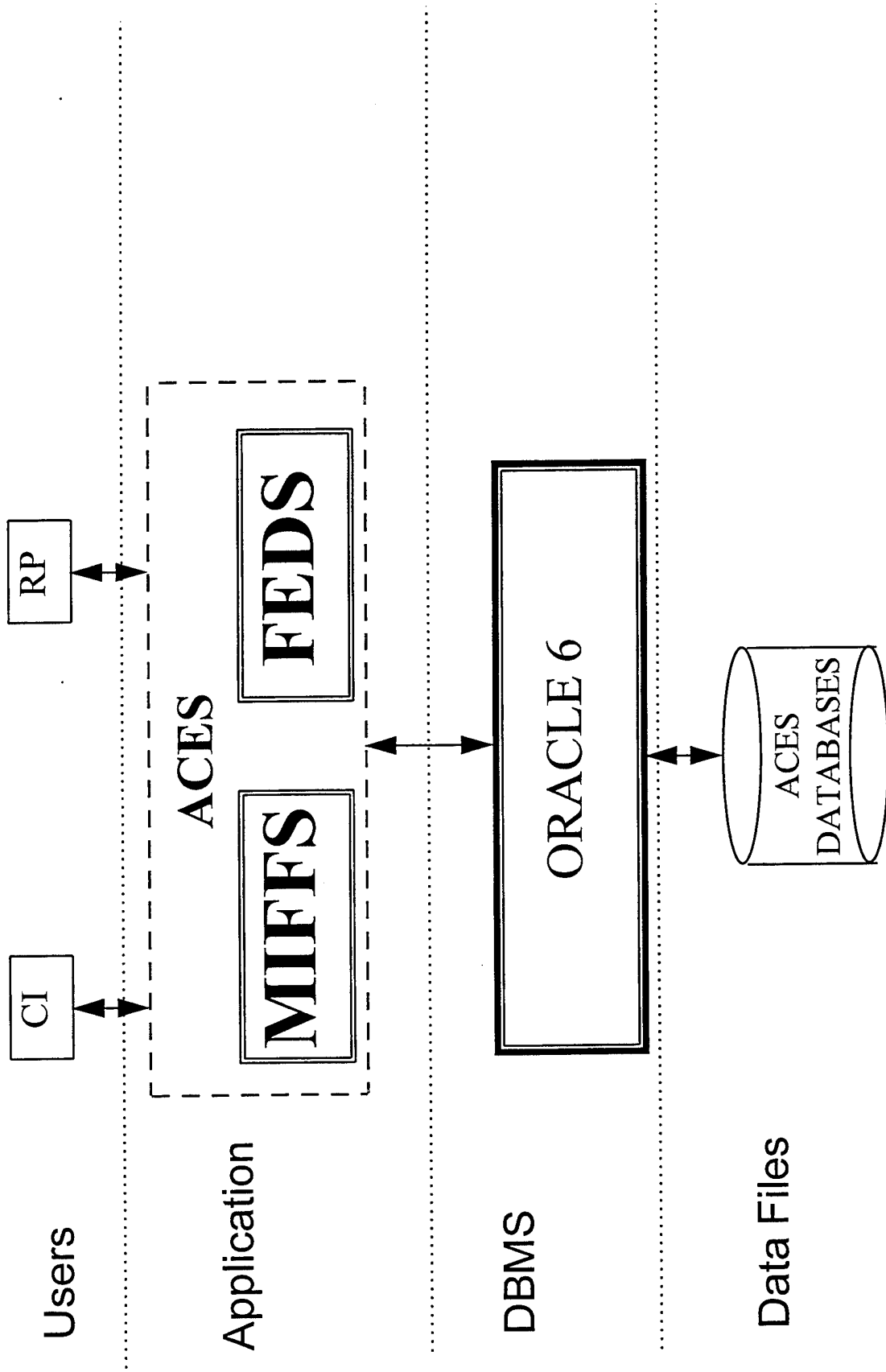

Personnel Systems Management (PSM)

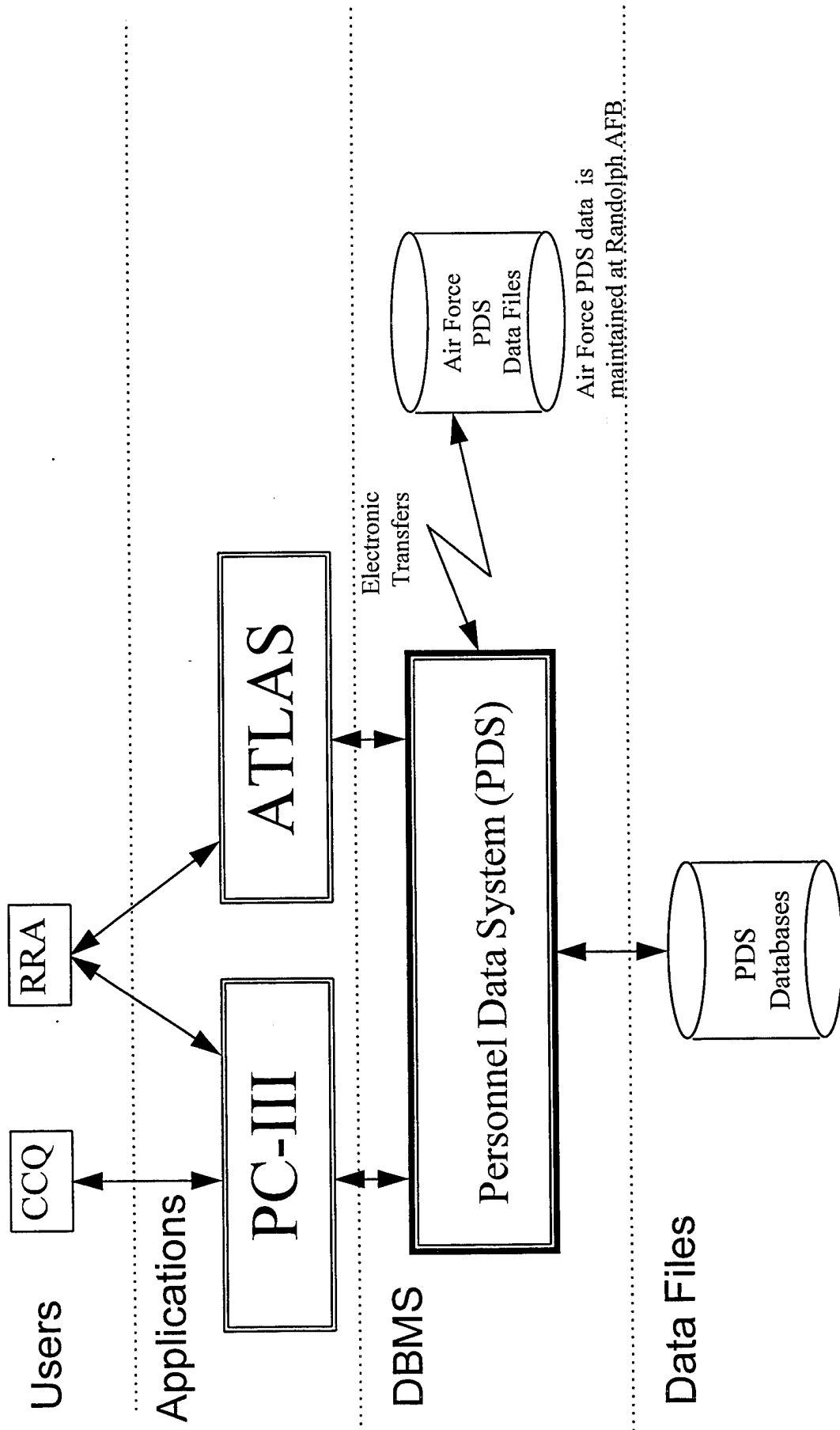

Civil Engineering and Services School (CESS)

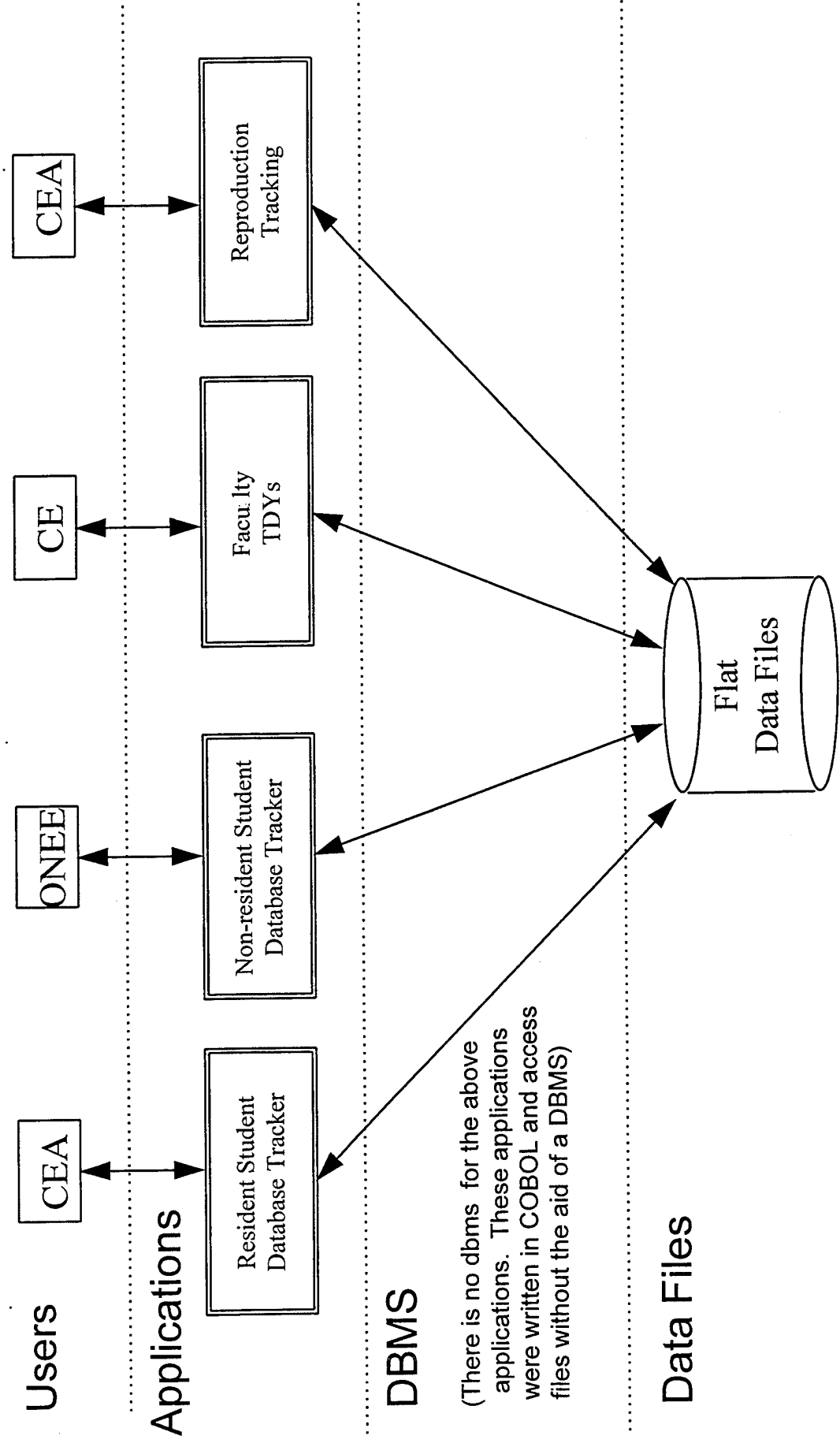

Defense Financial Accounting System (DFAS)

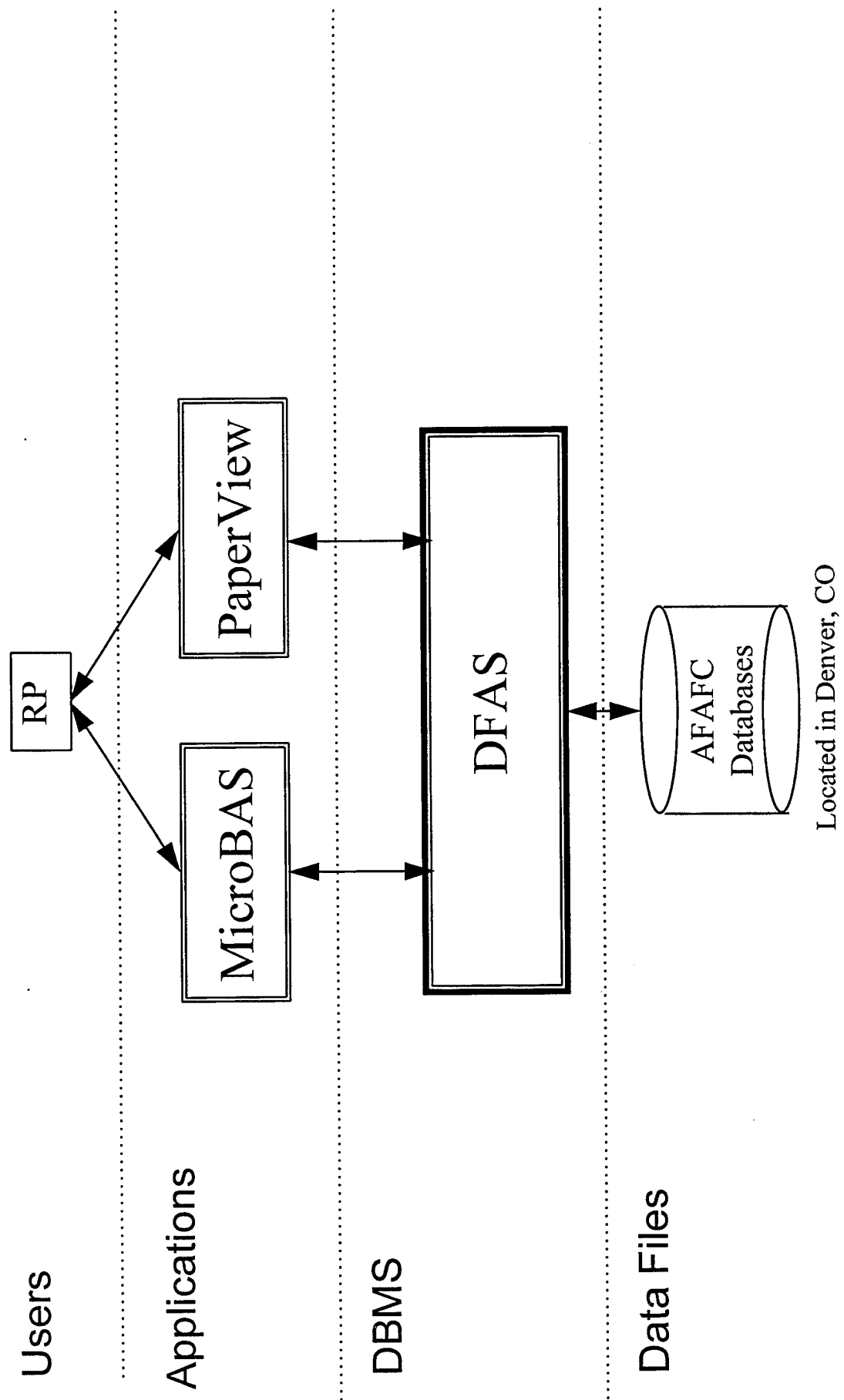

Information Processing Management System (IPMS)

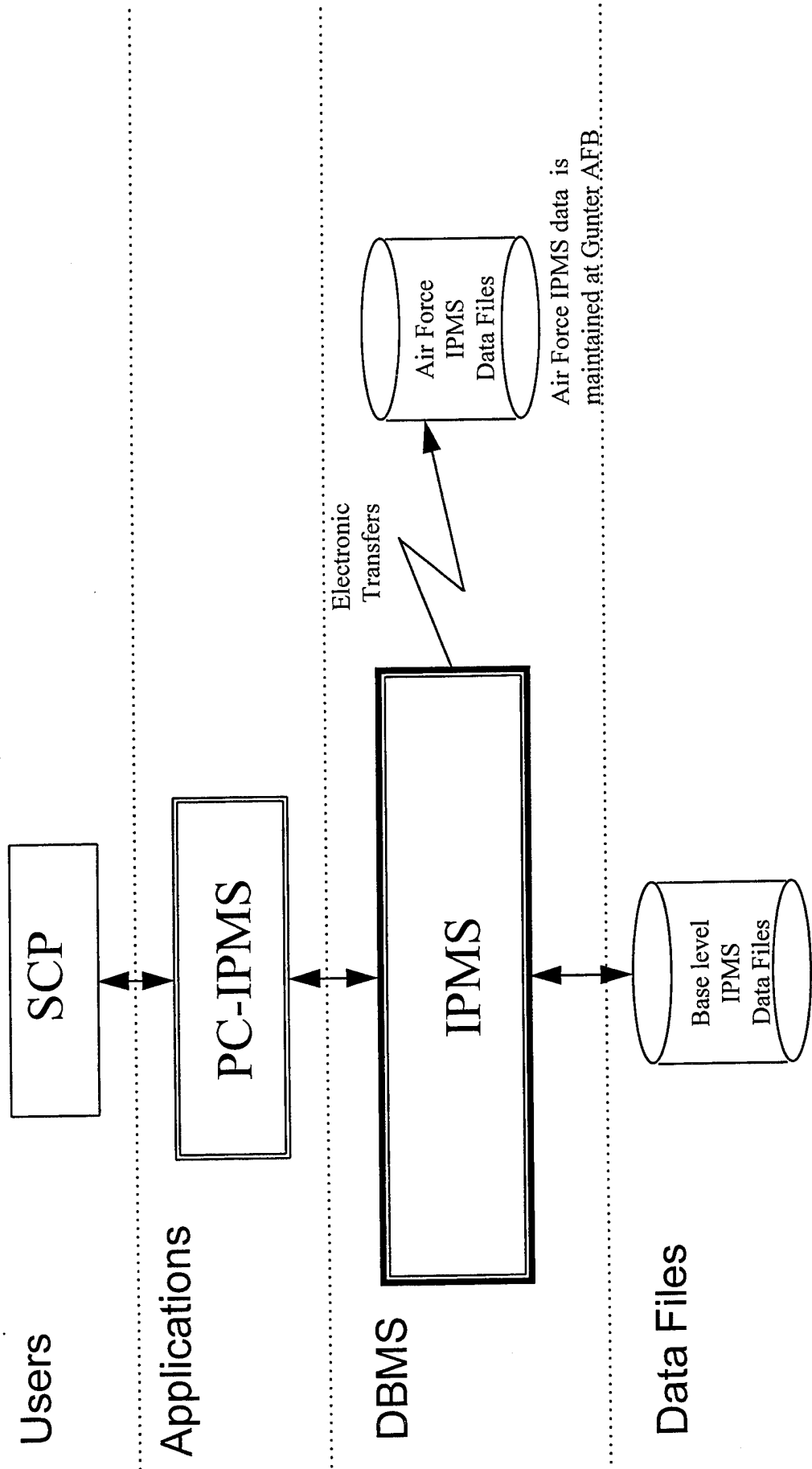

SC AF Forms 9 and 3215 Tracking

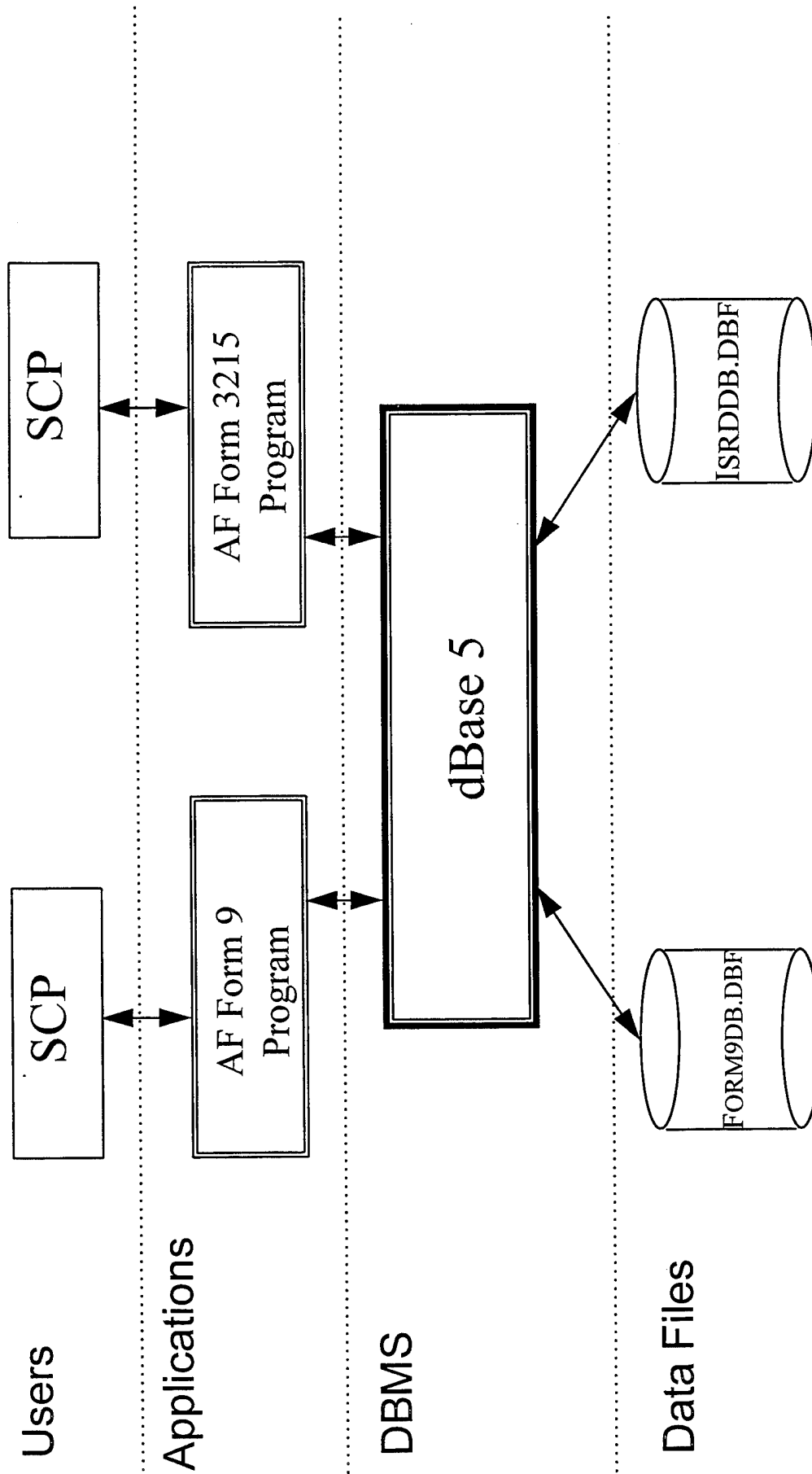

Project Tracking (PROTRAC)

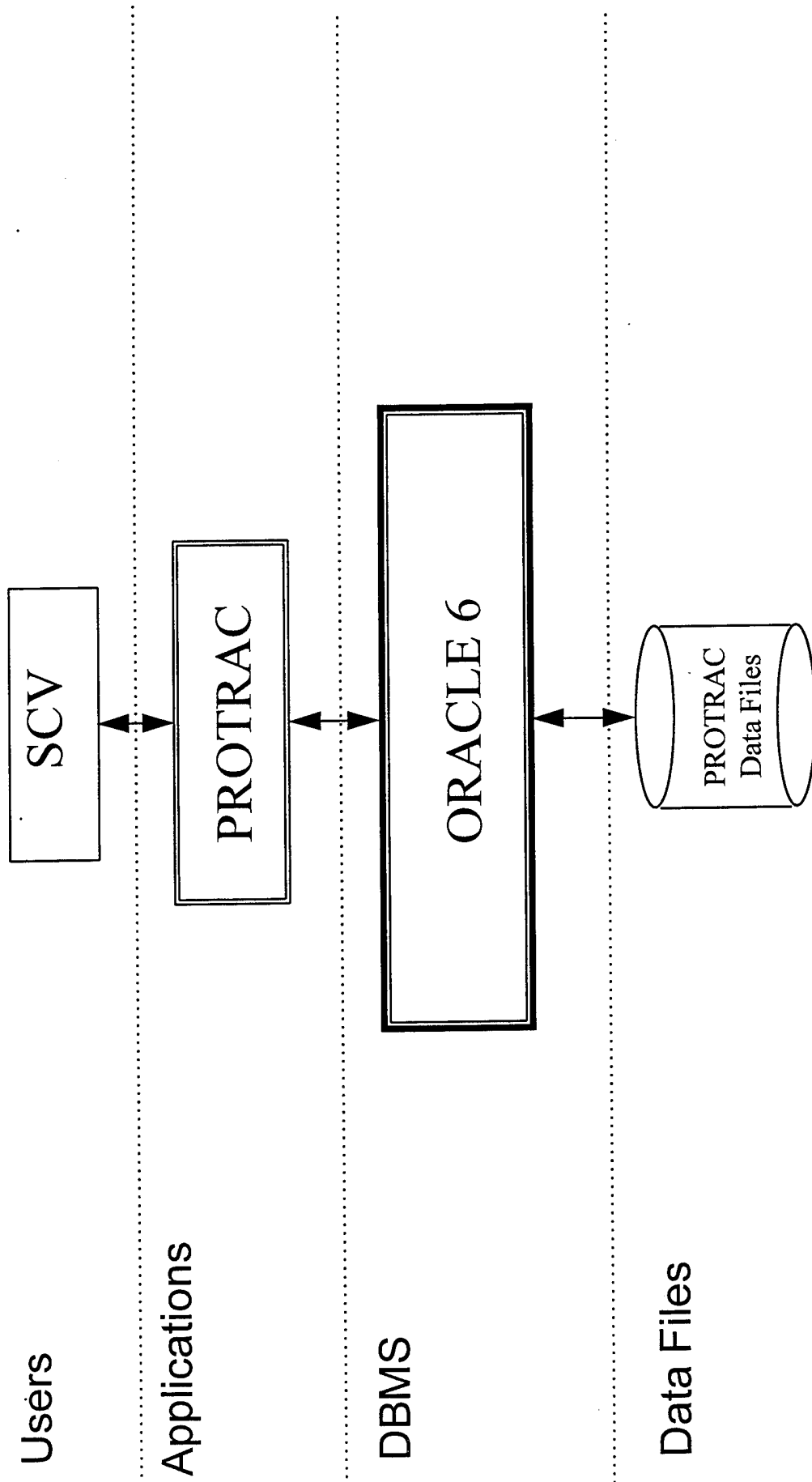

Library Financial and Publications Data

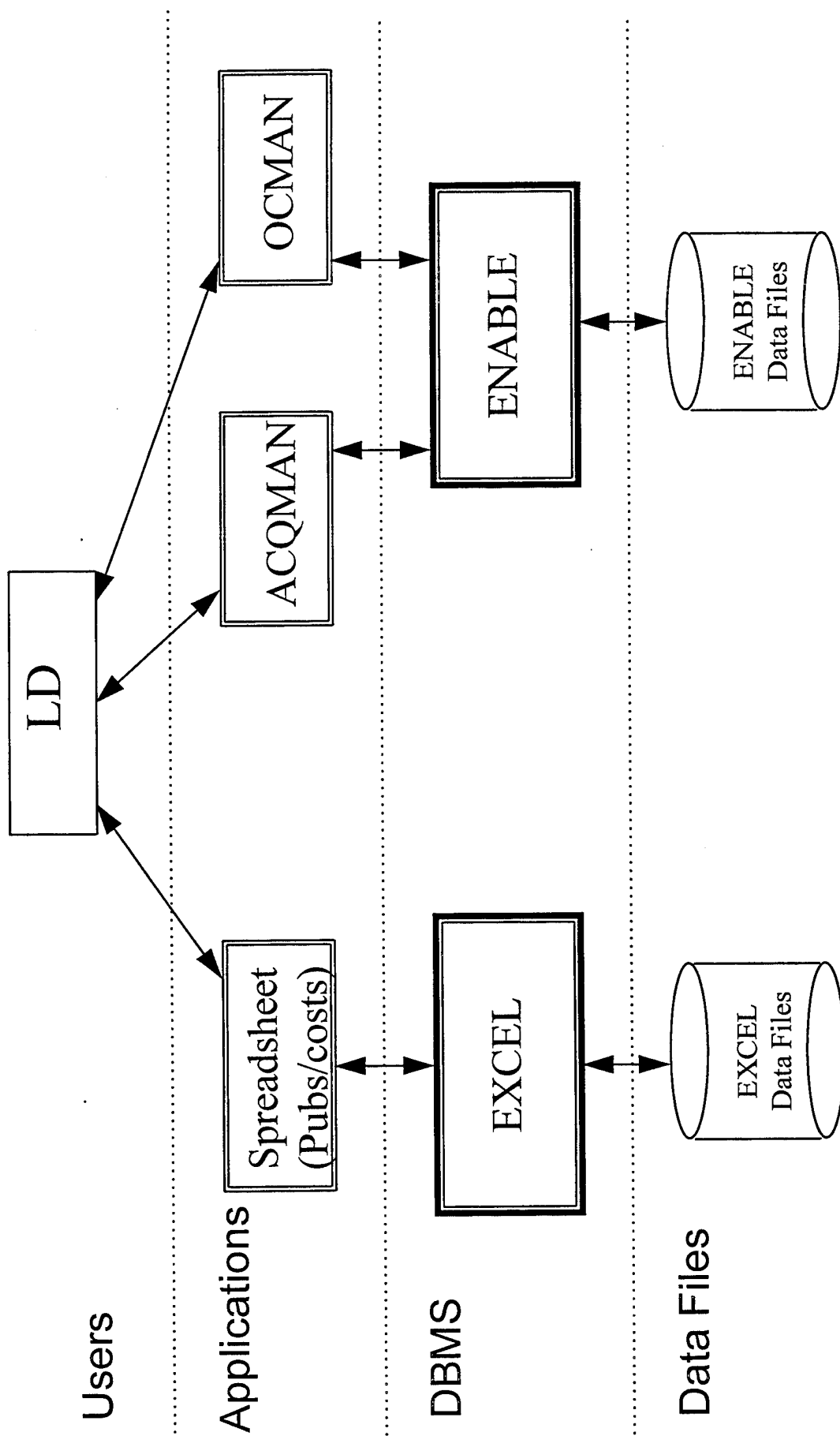

Student Information

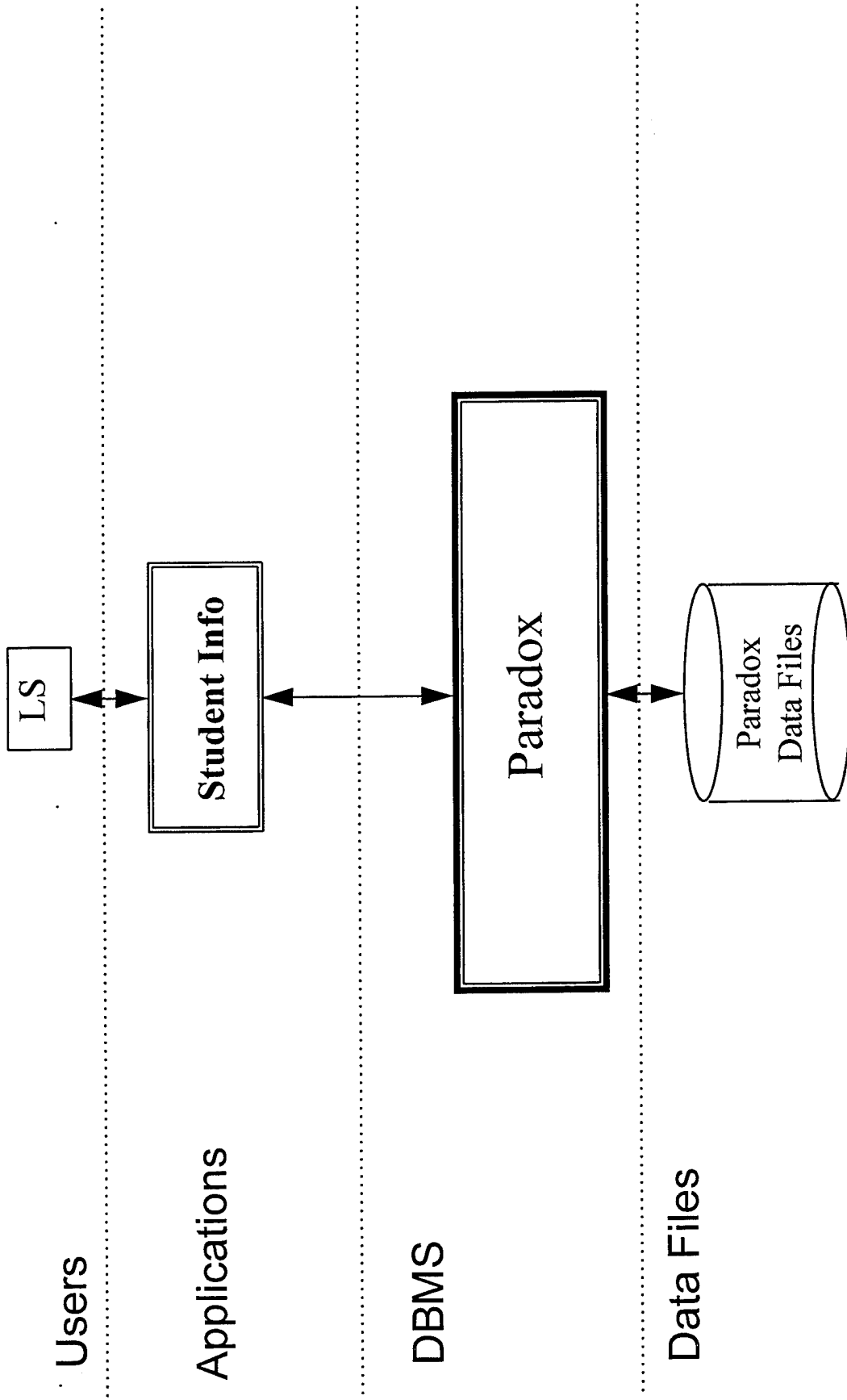

Typical Report Generation Procedure

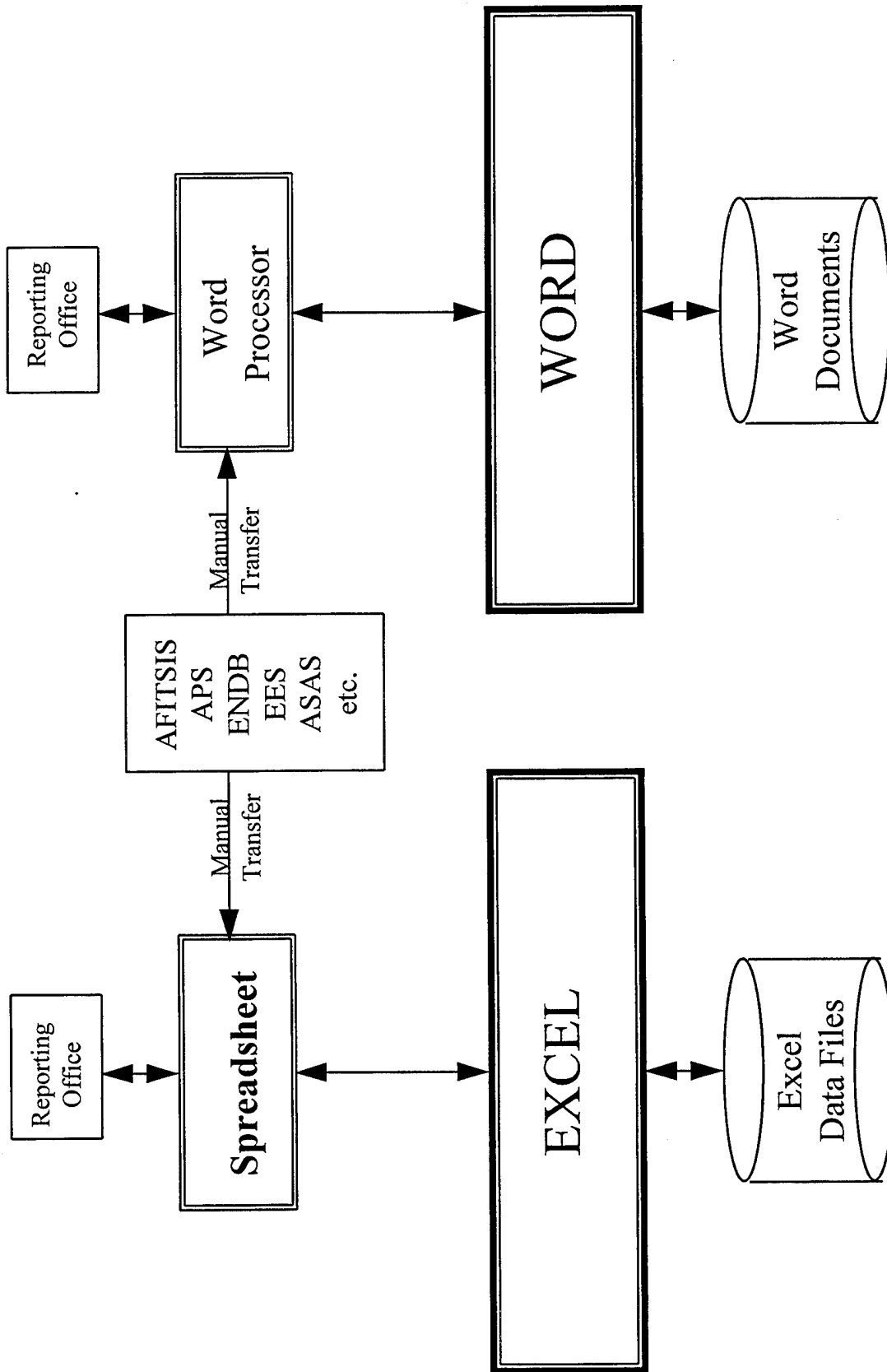

Example of a Report Generation Procedure

Air University Operating Plan (AUOP)

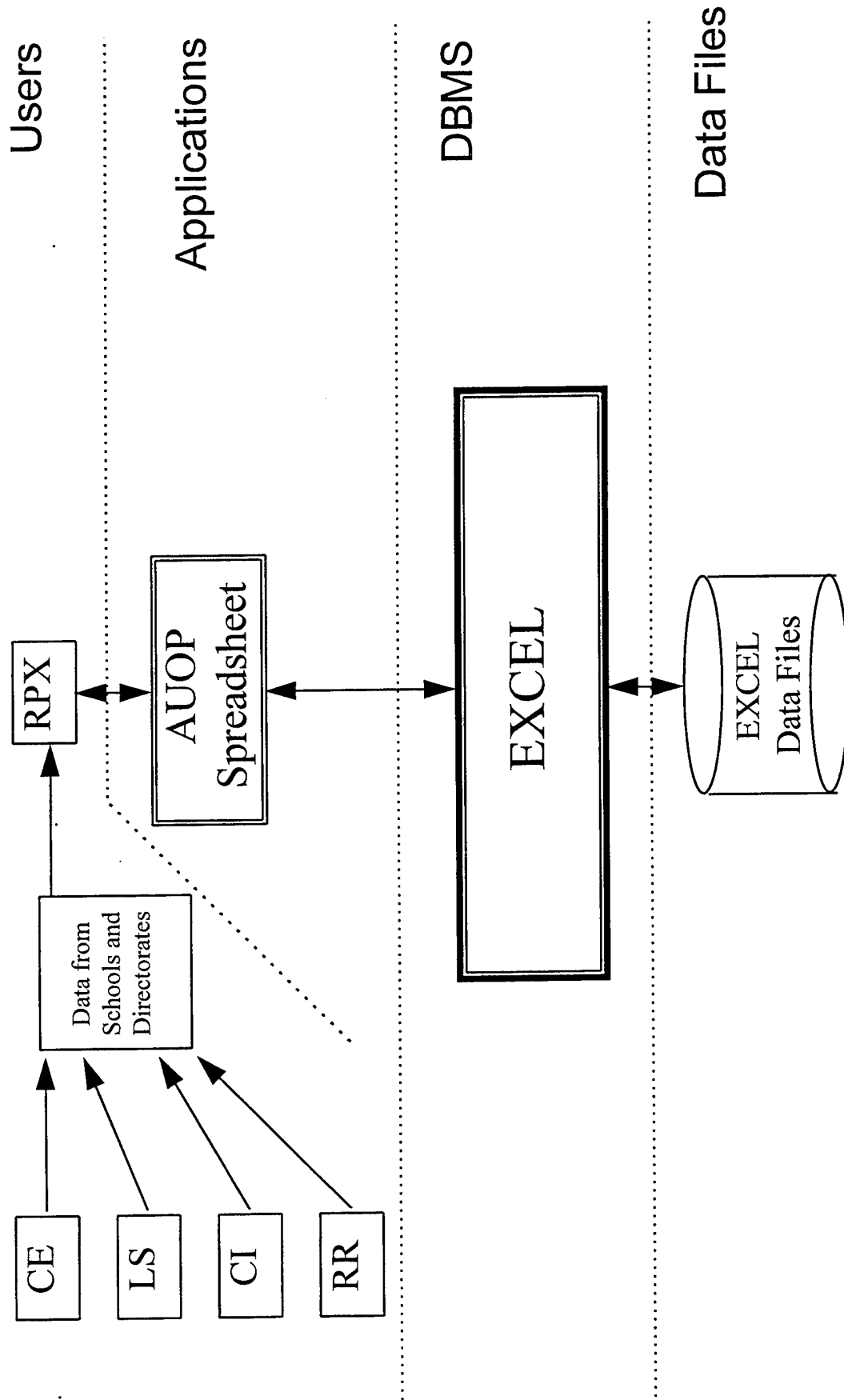

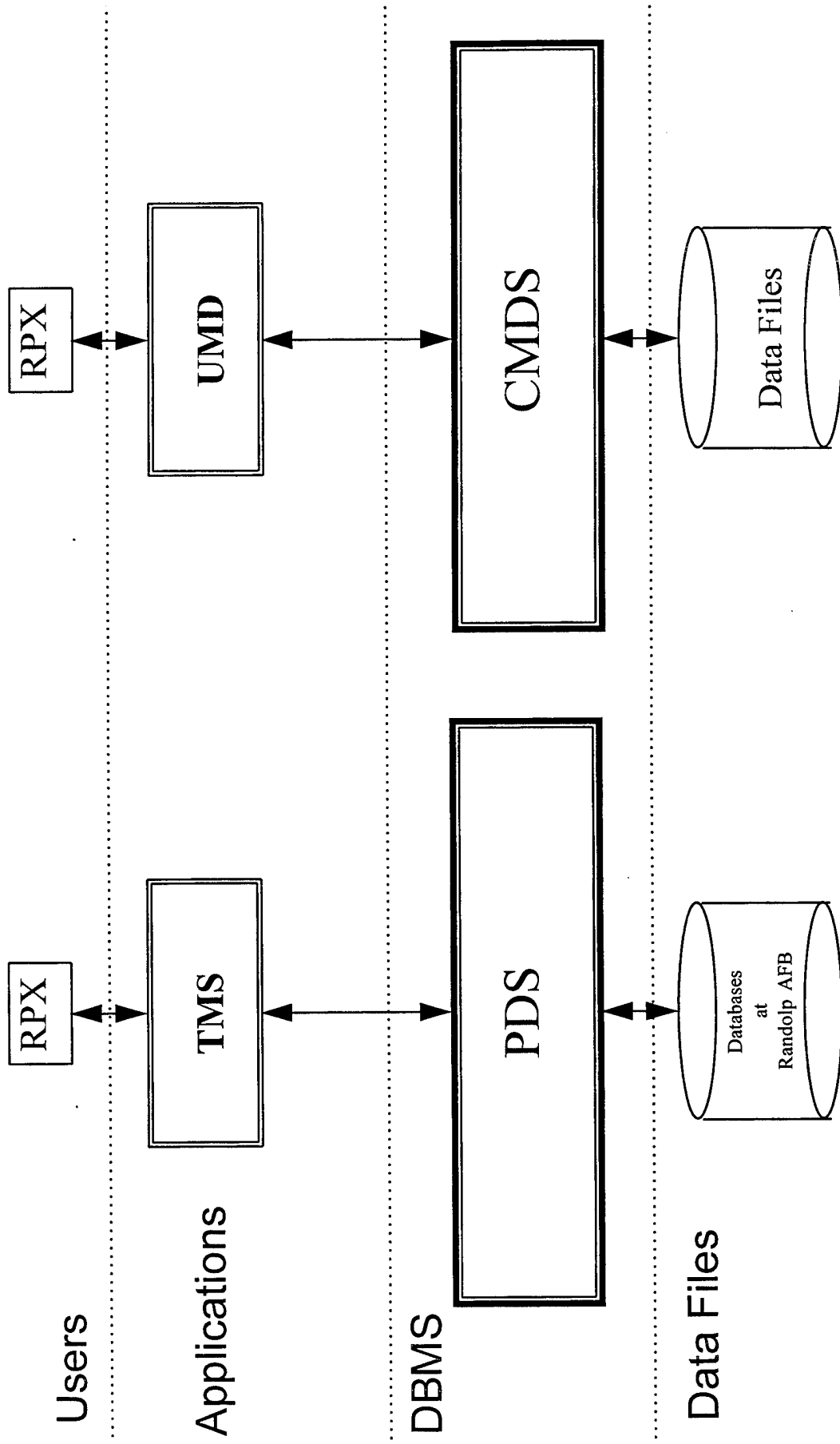

Examples of Manual Information Retrieval

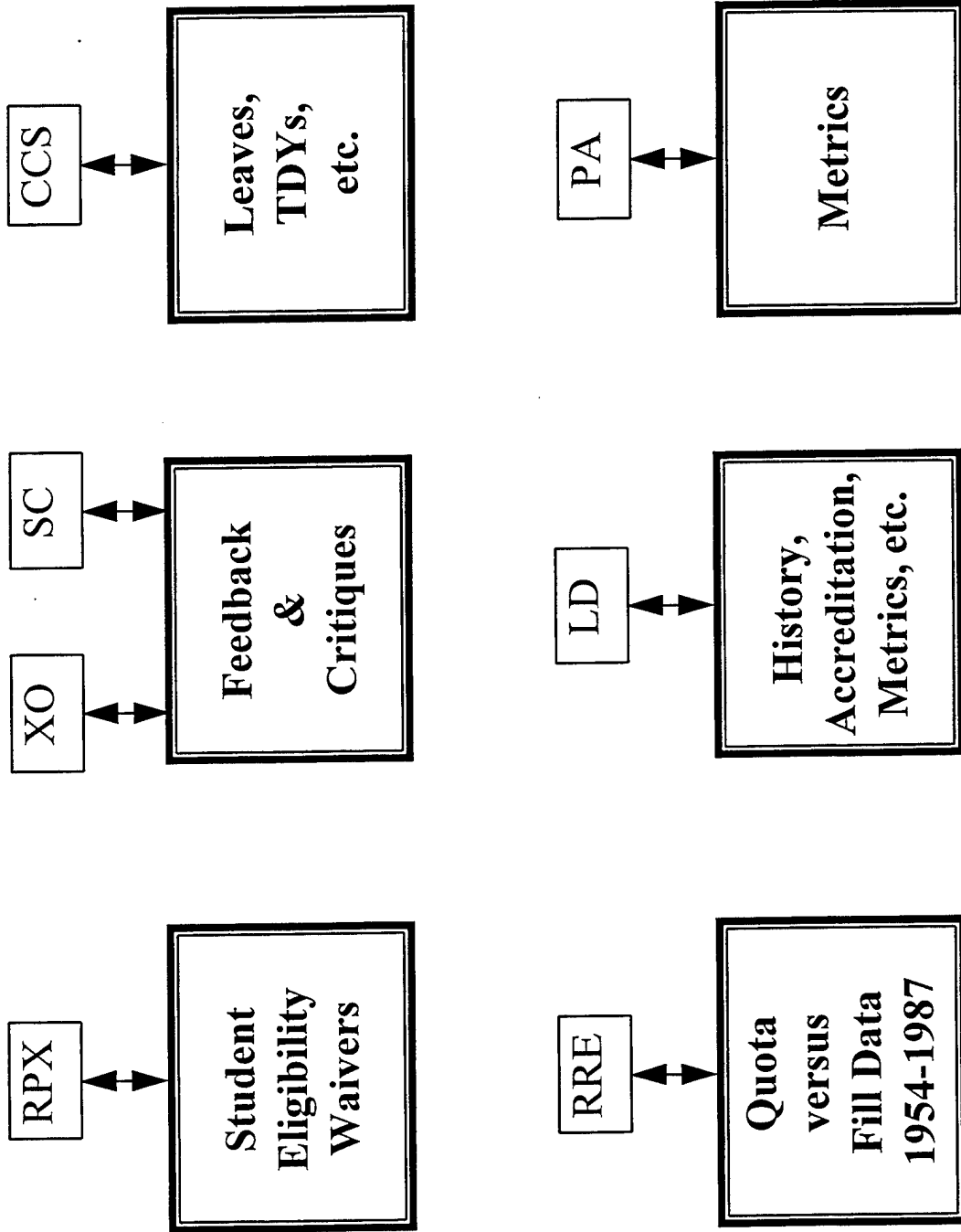

APPENDIX 2

(This section is available upon request from
Dr. Alan Heminger
AFIT/LAR, aheminge@afit.af.mil)

Glossary

	Page
Acronyms and Definitions	2
APPLICATIONS	5
DATABASE MANAGEMENT SYSTEMS	7

Acronyms and Definitions

ACES - AFIT's Civilian Education System. Includes MIFFS and FEDS.

Access - Relational database management system (RDBMS) by Microsoft ®. Software with the ability to create and manipulate databases.

ACQMAN - Financial software used by the library (LD). Its use is mandated by Central AF Services. Operates through the integrated software package known as Enable ®.

ADAMS - Academic Data And Mass Storage.

ADPE - Automated Data Processing Equipment.

AFITSIS - AFIT Student Information System. Includes STARS, QUEST (QUOTA), ISA, MSI, and MSQ.

AFPC - Air Force Personnel Center.

AFTMS - Air Force Training Management System

APS - AFIT Personnel Management System (formerly PMS)

ASAS - Automated Space Allocation System.

ATRRS - Army Training Resource and Requirements System.

ATLAS - The Headquarters Air Force (HAF) information retrieval system. A structured query language (SQL) used to access data in PC-III.

AUOP - Air University Operating Plan.

CMDS - CoMmand Database System.

COBOL - COmmon Business Oriented Language.

Configuration Control Board (CCB) - A formally constituted board where members are assigned specific program and project responsibility. The CCB will make decisions on major changes to established software, automated data processing equipment, and documentation baselines.

Context Diagram - Overview data flow diagram depicting an entire system as a single process with its major inputs and outputs.

Data Administrator - An organizational function responsible for database planning and for establishing policies for accessing and maintaining databases.

Database Administration - An organizational function responsible for the technical aspects of establishing and maintaining databases, in line with the policies laid down by the data administrator.

Data Flow Diagram (DFD) - A graphic representation of the flow of data throughout a system.

Data Flows - The movement of data between processes, external entities, and data stores in a data flow diagram.

Data Stores - Manual or automated inventories of data.

dBase 5 - A RDBMS by Borland ®. Software with the ability to create and manipulate databases.

DBMS - DataBase Management System.

DIN - Data Identification Number. Used in PC-III applications.

EES - Equivalency Exam System

EIS - Executive Information System. Information systems which provide higher-level managers with direct and easy access to aggregated information and detailed data.

ENDB - AFIT/EN Database Applications.

Excel - Spreadsheet application from Microsoft ®.

FEDS - Financial Expense Data System. Subsystem of ACES.

Fourth Generation Language - A very-high-level programming language that permits the programmer or user to specify what is wanted from the computer rather than how this should be obtained. Many of these languages are directly employed by end users.

GDSS - Group Decision Support System - Information systems designed to support group communications and decision processes.

GUI - Graphical User Interface. A user interface that relies on Windows, cursor-control devices (for example, a mouse), icons, and menus instead of verbal commands.

IPMS - Information Processing Management System. Stores ADPE data for the Air Force. The IPMS database is located at Gunter AFB.

ISA - International Student Affairs. Subsystem of AFITSIS.

MIFFS - Mgt Information Financial Forecasting System. Subsystem of ACES.

MSI - Mission Support Information. Subsystem of AFITSIS.

MSQ - MSQ Orderly Functions. Subsystem of AFITSIS.

OCMAN - Financial software used by the library (LD). Its use is mandated by Central AF Services. Operates through the integrated software package known as Enable ®.

Oracle - A commercial RDBMS incorporating the SQL data access language.

Paradox - A database application and development system available in DOS and Windows.

PC-III - Personnel Concept 3. The Air Force's Personnel data system (PDS) which has the capability to store, update, and retrieve data on all Air Force personnel. The system has a direct link to AFPC. The PSM is in charge of maintaining the system. AFIT's PSM is located in RRA.

PC-IPMS - Personal Computer Information Processing Management System. SC uses PC-IPMS to update local IPMS database which contains ADPE data. Periodically, PC-IPMS is used to electronically update the Air Force's host IPMS database which is located at Gunter AFB.

PDS - Personnel Data System.

PowerPoint - Presentation graphics program by Microsoft ®.

PROTRAC - Project Tracking system developed by SC.

PSM - Personnel Systems Manager. Individual in charge of maintaining PC-III. AFIT's PSM is located in RRA.

RDBMS - Relational DataBase Management System.

Query Language - A fourth-generation language for retrieving data from databases.

QUEST - QUota Education & Selection Transactions (a.k.a. QUOTA) . Subsystem of AFITSIS.

SQL - Structured Query Language.

STARS - STudent Records System. Subsystem of AFITSIS.

Synonyms - An alias for a table, view, sequence, or program.

Table - A basic unit of storage in an ORACLE database.

View - A custom-tailored presentation of the data in one or more tables.

Word - Word processing application by Microsoft ®.

APPLICATIONS

ACES - AFIT's Civilian Education System. Includes MIFFS and FEDS.

ACQMAN - Financial software used by the library (LD). Its use is mandated by Central AF Services. Operates through the integrated software package known as Enable ®.

ADAMS - Academic Data And Mass Storage.

AFITSIS - AFIT's Student Information System. Includes STARS, QUEST (QUOTA), ISA, MSI, and MSQ.

AFTMS - Air Force Training Management System

APS - AFIT Personnel Mgt System (formerly PMS)

ASAS - Automated Space Allocation System.

ATLAS - The Headquarters Air Force (HAF) information retrieval system. A structured query language (SQL) used to access data in PC-III.

ATRRS - Army Training Resource and Requirements System.

CMDS - CoMmand Database System.

EES - Equivalency Exam System

ENDB - AFIT/EN Database Applications.

Excel - Spreadsheet application from Microsoft ®.

FEDS - Financial Expense Data System. Subsystem of ACES.

IPMS - Information Processing Management System. Stores ADPE data for the Air Force. The IPMS database is located at Gunter AFB.

ISA - International Student Affairs. Subsystem of AFITSIS.

MIFFS - Mgt Information Financial Forecasting System. Subsystem of ACES.

MSI - Mission Support Information. Subsystem of AFITSIS.

MSQ - MSQ Orderly Functions. . Subsystem of AFITSIS.

OCMAN - Financial software used by the library (LD). Its use is mandated by Central AF Services. Operates through the integrated software package known as Enable ®.

PC-IPMS - Personal Computer Information Processing Management System. SC uses PC-IPMS to update local IPMS database which contains ADPE data. Periodically, PC-IPMS is used to electronically update the Air Force's host IPMS database which is located at Gunter AFB.

PowerPoint - Presentation graphics program by Microsoft ®.

PROTRAC - Project Tracking system developed by SC.

QUEST - QUota Education & Selection Transactions (a.k.a. QUOTA) . Subsystem of AFITSIS.

STARS - STudent Records System. Subsystem of AFITSIS.

DATABASE MANAGEMENT SYSTEMS

Access - Relational database management system (RDBMS) by Microsoft ®. Software with the ability to create and manipulate databases.

dBase 5 - A RDBMS by Borland ®. Software with the ability to create and manipulate databases.

Oracle - A commercial RDBMS incorporating the SQL data access language.

Paradox - A database application and development system available in DOS and Windows.

PC-III - Personnel Concept 3. The Air Force's Personnel Data System (PDS) which has the capability to store, update, and retrieve data on all Air Force personnel. The system has a direct link to AFPC. The PSM is in charge of maintaining the system. AFIT's PSM is located in RRA.

APPENDIX 4
DRAFT REGULATIONS

24 Feb 94

COMMUNICATIONS-COMPUTER SYSTEMS
ESTABLISHMENT OF AFITDB CONFIGURATION CONTROL BOARDS - (cc 3)

This regulation defines the policy, process, and responsibility for conducting the AFIT Configuration Control Board and Configuration Control Sub-Boards for all software associated with AFIT/SC managed corporate databases (AFITDB) and all AFIT/SC managed automated data processing equipment (ADPE). The provisions of this regulation relate to all personnel having software or ADPE that falls under the control and responsibility of AFIT/SC.

1. REFERENCES :

- a. AFITDB SOFTWARE CONFIGURATION MANAGEMENT PLAN
- b. AFR 14-1 CONFIGURATION MANAGEMENT
- c. AFR 700-4 COMMUNICATIONS-COMPUTER SYSTEMS PROGRAM MANAGEMENT

2. PURPOSE :

a. This regulation governs users of subsystems or databases that makeup the AFIT/SC managed AFITDB and all AFIT ADPE. Procedures outlined herein provide AFIT organizations a method to request a change or enhancement to a system, obtain needed feedback on the change, and obtain official approval so that the change may be incorporated into the subsystem.

b. The objectives behind the establishment of the configuration management control boards, to include the sub-boards, are:

- 1) to provide a simple, organized method for the approval/validation of all changes made to systems within AFITDB,
- 2) to ensure system integrity is maintained while incorporating new software or hardware to all subsystems,
- 3) to prioritize requirements based upon mission criticality, manpower, and urgency of need.

Number of printed pages: ??
OPR and Editor: AFIT/SCV (B. Cerny)
Approved by: ??
Distribution: ??

XX-CCB-04
24 Feb 94

Configuration Management Procedure
for
Air Force Institute of Technology (AFIT)
Configuration Control Board and Sub-Configuration Control Boards

Table of Contents

	Page
1. Explanation of Terms	1
2. Policy	4
3. CCB Procedure	5
4. Responsibilities	6
5. Software and Hardware Configuration Control Sub-Board Procedures.....	8

Attachments

	Page
1. Pre-Board Review Sheet	13
2. CCB Action Item	14
3. Summary of Changes	15

CONFIGURATION MANAGEMENT PROCEDURE

Title : Configuration Control Board

This procedure defines the policy, process, and responsibility for conducting the Configuration Control Board (CCB) and Configuration Control Sub-boards (SCCSB) for all AFIT Automated Data Processing Equipment (ADPE) and AFIT Database (AFITDB) software. The provisions of this procedure apply to all personnel using, developing, or testing software that falls under the control of AFITDB, and personnel planning to use and using ADPE within AFIT. This is an incremental, detailed procedure relating to the AFIT Software Configuration Management Plan (SCMP) and the five-year Communications-Computer Systems (CCS) Assessment (draft). Both of these documents are managed by AFIT/SC.

1. EXPLANATION OF TERMS:

a. Configuration Management (CM) : A discipline applying technical and administrative direction and surveillance to

(1) identify and document the functional and physical characteristics of a configuration item,

(2) control changes to those characteristics, and

(3) record and report change processing and implementation status.

In this procedure, the configuration management office (CMO) will be AFIT/SCV.

b. Configuration Control Board (CCB): A formally constituted board within AFIT. Members are assigned specific program and project responsibility. The CCB will make decisions on major changes to established software, ADPE, and documentation baselines. This board will meet to make decisions that cannot be made at the sub-board level.

c. Software Configuration Control Sub-boards (SCCSB): A formally constituted board within AFIT having members with specific program and project responsibility which will provide decisions in controlling changes to the established software baselines.

d. Hardware Configuration Control Sub-boards (HCCSB): A formally constituted board within AFIT having members with specific program and project responsibility which will provide decisions in

*Controls, changes and other things shall be defined in
EXPLANATION OF TERMS*

controlling changes to the established ADPE baselines.

e. Communications-Computer Systems Requirement Document (CCSRD) AF Form 3215: This form will be used to propose a class I (major) change to the existing software or ADPE baseline. It describes the proposed change and it's impact on cost, schedule, and performance of the subsystems involved. This form is also used for changes that result in a new capability.

f. Software System Enhancement Request (SSER): The SSER describes a class II (minor) software change or a discrepancy or deficiency in a given software application. It is an automated form accessed from electronic mail. An SSER is not used ~~to~~ for changes that result in a new capability.

g. ADPE System Enhancement Request (ASER): The ASER describes a class II (minor) hardware change or a discrepancy or deficiency in any given ADPE. It is an automated form accessed from electronic mail. An ASER is not used ~~to~~ for changes that result in a new capability.

h. Configuration Item: The smallest unit tracked for configuration management (e.g. software functions or applications, printers, network servers)

i. Change Class: A Class I change effects the form, fit, and/or function of a configuration item (i.e. software upgrade, new mother board). A Class II change is minor in nature and does not impact the form, fit and/or function of a configuration item. (i.e. a typographical error in software, a cable change)

j. Change Notice: Generic name for a CCSR, ASER, or SSER. Used when a specific type of form doesn't need to be addressed.

k. Summary of Change: This section is located at the end of the document and reflects all past changes made to this document.

l. Configuration Control Board Directive (CCBD): formal written effect/recommendation/concurrence of a CCB meeting signed by the CCB Chairperson.

m. Management Information Financial Forecasting System (MIFFS). MIFFS provides education tracking and financial information for students attending civilian institutions. MIFFS contains the following subsystems:

(1) AFIT Civilian Education System (ACES). ACES is a management information system that is used to maintain information concerning students assigned to Civilian Institution Programs (CI), the civilian institutions students attend, and the programs and program offices within the Directorate of CI to which the students are assigned. ACES was developed so that CI staff can quickly

generate management reports, can track forms and other paperwork, can schedule training reports, and can generate statistical information concerning CI students and programs.

(2) Resources Commercial Services Directorate (RPBD) Financial Expense Data Systems (FEDS). FEDS is a financial data management system developed to enhance the interface between CI and RPBD. FEDS tracks cost data, vouchers, surveys, agreements between civilian institutions and AFIT, budget estimations, and other financial information. FEDS is closely tied to the ACES data tables.

n. AFIT Student Information System (AFITSIS). AFITSIS is a series of database application packages designed to integrate school related functions into a centralized database. AFITSIS concentrates on functions associated with the resident graduate education students. It currently provides information and functions for in-processing, registration, educational planning, scheduling course offerings, grading, international student affairs, and publishing graduation transcripts. AFITSIS contains the following subsystems:

(1) Student Tracking and Registration System (STARS) is designed to maintain AFIT student information from admittance to graduation. Student records are accessible to the registrar's office, the School of Systems and Logistics, and the School of Engineering. The registrar's office uses the system to maintain educational history necessary to produce a transcript. The schools have the capability to view the information entered by the registrar pertaining to their school only and also to create and modify ed-plans and thesis data for a student.

(2) AFIT Orderly Room System (CCQ) is designed to maintain information applicable to the functions of the orderly room. This includes box numbers, locker numbers, section leaders, security access badges, building access codes, [weigh-in and physical training data, weight management program statistics, emergency locator information,] and other student information. CCQ produces student information sheets, alpha rosters, section leader rosters, book allowance listings, and mailing labels.

(3) International Student Affairs (ISA) is designed to maintain information of the international military students attending AFIT. This includes family, funding, sponsor, and informational program data.

(4) QUota Education and Selection Transactions (QUEST) is designed to track and maintain information related to a student selection for an AFIT or Civilian Institution (CI) program. It associates a student with a quota set by the Air Education Training Command (AETC). Records for student selected for an AFIT program are accessible through STARS and CCQ. Records for students

Handwritten note:
The list of...
AFITSIS M

selected for a CI program are accessible through ACES.

(5) Equivalency Exam System (EES) is designed to track students who take various exams offered by AFIT.

o. (ASAS) → *Who ...?*

p. AFIT Personnel System (APS). — *Who ...?*

2. POLICY:

a. Scope: *... published by AFIT/CC*
The CCB is an official advising Air Force group established by AFIT/SC. It is the official agent responsible to act on all Class I (major) changes and the baselining of AFITDB software subsystems and ADPE.

b. CCB Authority: Each member of the CCB is responsible for representing their functional area's position on each Class I change to the system. The CCB Chairperson, or alternate, has the authority to approve or disapprove all software or ADPE changes presented to the board. Members in attendance will certify their official position relative to the decision of the Chairperson by indicating either a concurrence or non-concurrence on the configuration control board directive (CCBD). Should a non-concurrence occur and a compromise cannot be reached in the CCB meeting, the dissenting member(s) may submit a written non-concurrence report to the Chairperson, along with an information copy to the CMO, within three working days subsequent to the meeting. [The Chairperson will review the report and make a decision before implementation of the CCBD.] → *The approval authority should be ...*

c. CCB Official Membership: The following members constitute the AFIT CCB:

(1) Software

(a) Chairperson: AFIT/CF (HORNER)

(b) ACES/MIFFS Member: AFIT/CI

(c) ACES/FEDS Member: AFIT/FM

(d) AFITSIS Member: AFIT/CV

(e) EES Member: AFIT/LS

(f) ASAS Member: AFIT/LS

(2) ADPE

(a) → *Who ... These members be*

(b)

(3) Secretary: CMO (AFIT/SC) or assigned CM representative for AFIT/SC.

(4) Other members and their alternates placed on this board will be appointed in writing. *b, when?*

d. Limitations/Constraints: The CCB will meet on an "as-needed" basis. The board will convene only when Class I changes are proposed and cannot be decided upon by the Sub-board(s) involved or a proposed change involves strategic goals of AFIT.

e. Criteria for Change Approval: Only changes which meet the following criteria will be considered for approval:

(1) Changes necessary to correct a deficiency in a given subsystem.

(2) Changes which will significantly increase the effectiveness or the operational performance of the system.

(3) Changes to make the system and/or configuration items compatible with other approved changes.

3. CCB PROCEDURE.

a. All CCSRDs, ASERs, and SSERs (change notices) will be routed to the AFIT/SC help desk for logging and tracking by the CMO.

b. The CMO will determine which CCSRDs are Class I and require CCB action and which SSERs/ASERs are Class II and require SCCSB or HCCSB action.

c. A CCB formal agenda listing all proposed change notices will be prepared and distributed by the CMO not later than three days prior to the scheduled board meeting.

d. Routine change notices will normally be scheduled to allow CCB members 25 days for review. Urgent change notices will be scheduled to allow CCB members 15 working days for review. Emergency change notices will receive immediate action.

e. CCB Action: All scheduled change notices will be reviewed by the CCB with the Chairperson's decision documented in the CCBD. CCB proceedings will not be considered final until the CCBD has been signed by the CCB Chairperson. The following options regarding disposition of change notices are available to the CCB Chairperson:

- 1) Approved as written.
- 2) Disapproved. (Reason for disapproval to be provided in the comments of the CCBD)
- 3) Approved with comments. (All comments will be documented in the CCBD)
- 4) Deferred for further investigation. The deferred change will be acted upon at the next CCB. The CMO and drafter of the proposed change notice will perform the investigation.

f. Optional Processing Procedures: The CCB Chairperson may authorize a walk through procedure to process a change notice which has an emergency program impact. The CMO will hand carry the signed CCBD to obtain a coordinated position from the CCB members. Items may be processed by the CCB Chairperson with coordination of only CCB members whose organizations are affected by the change.

g. CCB Meetings:

- 1) Meetings will normally be scheduled as needed by the CMO. However, the CCB Chairperson may call a special meeting at any time, date, and place where deemed necessary to meet system requirements. When a primary representative or designated alternate is not present at the CCB to sign the CCBD(s), and the CCB member has not communicated his/her position, the Chairperson will assume a negative reply to the change and the form will be left blank. When attendance is not possible, the member is responsible for communicating his/her position on the change to the Chairperson.
- 2) Action items may be assigned by the Chairperson to resolve unanswered questions concerning the change before the board makes a recommendation for final disposition. All CCB actions will become part of the official CCB meeting minutes.

4. Responsibilities:

a. CCB Chairperson:

- 1) Will approve/disapprove the agenda provided by the CMO.
- 2) Presides over all CCB meetings or designate an alternate in writing.
- 3) Determine the disposition of all change notices reviewed by the CCB.

b. CCB Members (or designated alternates):

- 1) Provide a recommendation or a negative reply on the pre-board Review Sheets (Attachment 1) to the OPR on the attached change notice not later than 2 days prior to the board date. Provide a copy of the Pre-Board Review Sheet to the CMO.
- 2) Reviews agenda and returns to the CMO no later than two days before the CCB meeting.
- 3) Will attend CCB meetings.

c. Office of Primary Responsibility (OPR):

- 1) Is assigned by the CMO based on the subject and nature of the change notice. This OPR will be identified on the CCB agenda and the Pre-board review sheet (see Attachment 1).
- 2) Must become completely familiar with all aspects of the change notice assigned to him/her.
- 3) Coordinates with the CMO and Chairperson to determine a meeting date.
- 4) Will review all pre-board review sheet comments from board members prior to the CCB.
- 5) Will present the change notice at the CCB. The presentation will cover all relevant aspects of the change notice.

d. Configuration Management Office (CMO):

- 1) Assigns an OPR based on the nature and subject of the change notice.
- 2) Contacts the OPR and Chairperson and establish^s a board date based upon the urgency of the change (see paragraph 3.d above).
- 3) Completes the Pre-board Review Sheet down to the suspense date on the form and attach^s the associated change notice. The Pre-board Review sheet and the change notice make a complete change package for copying and distribution. A copy of each change package will be given to each CCB member unless otherwise specified by the Chairperson. Each OPR, if not already a member of the CCB, will receive a copy of his/her change slated for board action. The distribution time frame will be in accordance with the urgency of change. A routine change

will be distributed no later than 25 days prior to the board meeting. An urgent change will be distributed no later than 15 days prior to the board meeting. And, an emergency change will be distributed no later than 8 hours prior to the board meeting unless an Optional Processing Procedure is used (paragraph 3f).

4) Prepares the CCB agenda and provides the agenda to the Chairperson for approval when required. Issues the agenda to all CCB members and OPRs at least five days prior to the CCB.

5) Reviews the agenda with the OPR(s) two days before the board and advises the CCB chairperson of pre-board actions to add, drop, or defer change notices to/from the agenda.

6) Distributes the presentation materials provided by the OPR to CCB attendees the day before the board is to convene.

7) Maintains a permanent record and backup file of all change notice activity.

8) Acts as Secretary by preparing CCBs prior to the board meeting for each change disposition and will take minutes in accordance with the direction given by the CCB Chairperson.

9) Tracks all Action Items from initial CCB action to closure (see Attachment 3).

5. Configuration Control Sub-Boards (SCCSB, HCCSB) Procedure

a. Policy:

(1) Scope: The SCCSB and HCCSB are official advising Air Force groups established by AFIT/SC. They are the official agents responsible to act on both class I (major) and class II (minor) changes that do not affect other AFITDB subsystems, existing ADPE, or the baselining of AFITDB software subsystems.

(2) SCCSB/HCCSB Authority: Each member of the SCCSB/HCCSB is responsible for representing their functional area's position on all proposed changes to the system. The SCCSB/HCCSB Chairperson, or alternate, has the authority to approve or disapprove all software changes presented to the board. Members in attendance will certify their official position relative to the decision of the Chairperson by indicating either a concurrence or non-concurrence on the configuration

control board directive (CCBD). Should a non-concurrence occur and a compromise cannot be reached in the CCB meeting, the dissenting member(s) may submit a written non-concurrence report to the Chairperson, along with an information copy to the CMO, within three working days subsequent to the meeting. [The Chairperson will review the report and make a decision before implementation of the CCBD.] *Approved by [unclear] [unclear] etc.*

(3) SCCSB Official Membership:

- AFITSIS Sub-Board:
- 1) Chairperson: AFIT/CV or alternate
 - 2) Subsystem Representatives: STARS (AFIT/RR), QUEST (AFIT/RRE), ISA (AFIT/RRI), CCQ (AFIT/MS), EES (AFIT/LA).
 - 3) CM Representative

- MIFFS Sub-Board:
- 1) Chairperson: AFIT/CI or alternate
 - 2) Subsystem Representatives: ACES (AFIT/CI), FEDS (AFIT/FM).
 - 3) CM Representative

(4) HCCSB Official Membership:

XXXX.....

b. Limitations/Constraints: Changes will not be incorporated into the production copy of the subsystem prior to SCCSB/HCCSB approval of a change notice.

(1) Criteria for Change Approval:

(a) Only changes which meet the following criteria will be considered for approval:

(1) Changes necessary to correct a deficiency in a given subsystem.

(2) Changes which will significantly increase the effectiveness of the operational performance of the subsystem.

(3) Changes to make the subsystem and/or configuration items compatible with other approved changes.

c. SCCSB/HCCSB Procedure

- 1) All change notices which require SCCSB/HCCSB action will be routed to the Configuration Management Office (CMO) for logging and tracking.

2) Change notices will be processed according to urgency.

3) SCCSB/HCCSB Action: All scheduled change notices will be reviewed by the SCCSB/HCCSB with the Chairperson's decision documented in the CCBD. SCCSB/HCCSB proceedings will not be considered final until the CCBD has been signed by the SCCSB/HCCSB Chairperson. The following options regarding disposition of change notices are available to the SCCSB/HCCSB chairperson:

a) Approved as written.

b) Disapproved. (Reason for disapproval to be provided in the comments of the CCBD)

c) Approved with comments. (All comments will be documented in the CCBD)

d) Deferred for further investigation. The deferred change will be acted upon at the next SCCSB/HCCSB or CCB.

e) Passed up to the CCB for action if concurrence cannot be reached or the change affects systems outside the scope of the subsystem.

4) Optional Processing Procedures: The SCCSB/HCCSB Chairperson may authorize a walk through procedure to process a change notice which has an emergency program impact. The CMO will hand carry the signed CCBD to obtain a coordinated position from the SCCSB/HCCSB members. Items may be processed by the SCCSB/HCCSB Chairperson with coordination of only SCCSB/HCCSB members whose organizations are affected by the change.

5) SCCSB/HCCSB Meetings:

a) Meetings will normally be scheduled as needed by the CMO. However, the SCCSB/HCCSB Chairperson may call a special meeting whenever deemed necessary to meet system requirements. When a permanent representative or designated alternate is not present at the SCCSB/HCCSB to sign the CCBD(s), and the SCCSB/HCCSB member has not communicated his/her position, the Chairperson will assume a negative reply to the change and the form will be left blank. When attendance is not possible, the member is responsible for communicating his/her position on the change to the

Chairperson.

b) Action items may be assigned by the Chairperson to resolve unanswered questions concerning the change before the board recommends a final disposition. All SCCSB/HCCSB actions will become part of the official SCCSB/HCCSB meeting minutes.

d. Responsibilities:

1) Office of Primary Responsibility (OPR):

a) Is assigned by the CMO based on the subject and nature of the change notice. This OPR will be identified on the SCCSB/HCCSB agenda and the Pre-board review sheet (see Attachment 1).

b) Must become completely familiar with all aspects of the change notice assigned to him/her.

c) Coordinates with the CMO and Chairperson to determine a SCCSB/HCCSB meeting date.

d) Reviews all pre-board review sheet comments from board members prior to the SCCSB/HCCSB.

e) Presents the change notice at the SCCSB/HCCSB. The presentation will cover all relevant aspects of the change notice.

2) SCCSB/HCCSB Chairperson:

a) Approves/disapproves the agenda provided by the CMO.

b) Presides over SCCSB/HCCSB meetings or designate an alternate in writing.

c) Determines the disposition of all change notices reviewed by the SCCSB/HCCSB.

3) SCCSB/HCCSB Members (or designated alternate):

a) Provide a recommendation or a negative reply on the pre-board Review Sheets (Attachment 1) to the OPR on the attached change notice not later than 2 days prior to the board date. Also, a copy of the disposition form must be returned to the CMO.

b) Attend SCCSB/HCCSB meetings.

4) Configuration Management Office (CMO):

- a) Assigns an OPR based on the nature and subject of the change notice.
- b) Contacts the OPR and establish a board date based upon the urgency of the change.
- c) Completes the Pre-Board Review Sheet down to the suspense date on the form and attach the associated change notice. The Pre-Board Review sheet and the change notice make a complete package for copying and distribution. A copy of each change package will be given to each SCCSB/HCCSB member unless otherwise specified by the Chairperson. Each OPR, if not already a member of the SCCSB/HCCSB, will receive a copy of his/her change slated for board action. The distribution time frame will be in accordance with the urgency of change. A routine change will be distributed no later than 14 days prior to the board meeting. An urgent change will be distributed no later than 7 days prior to the board meeting. And, an emergency change will be distributed no later than 8 hours prior to the board meeting unless Optional Processing Procedure, or walk through, is used.
- d) Prepares the SCCSB/HCCSB agenda and provides the agenda to the Chairperson for approval when required. Issues the agenda to all SCCSB/HCCSB members and OPRs at least five working days prior to the SCCSB/HCCSB.
- e) Reviews the agenda with the OPR(s) the day before the board and advises the SCCSB/HCCSB chairperson of pre-board actions to add, drop, or defer change notices to/from the agenda.
- f) Distributes the presentation materials provided by the OPR to SCCSB/HCCSB attendees two days before the board is to convene.
- g) Maintains a permanent record and backup file of all change notice activity.
- h) Acts as Secretary by preparing CCBDS prior to the board meeting for each change disposition and will take minutes in accordance with the direction given by the SCCSB/HCCSB Chairperson.
- i) Tracks all Action Items from initial SCCSB/HCCSB action to closure (see Attachment 2).

Attachment 1: Pre-Board Review Sheet

Configuration Control Board Pre-Board Review Sheet (Item/Title) for review by _____, CCB Member, or his/her alternate _____.

1. The attached item is forwarded for your review and comments prior to CCB action. Please send this form with your recommendation and applicable comments on this item to the OPR noted below:

2. This item is tentatively scheduled for presentation to the CCB on _____. A firm date and agenda will be distributed one week prior to the meeting of the CCB.

(Chief, Division Name or CMO)
AFIT

1 Atch

1st Ind

Date _____

To: OPR

Copy: AFIT/SCV (CMO)

Suspense date _____

Recommend: Approval _____ Disapproval _____

Comments:

Signature of CCB member

Attachment 2: CCB Action Item

CCB Action Item

Date Issued: _____ Action Item #: _____
Suspense: _____ Status: _____
Initiator: _____ Date Closed: _____

To: _____

Subject: _____

Request Action: _____

Action Taken: _____

DRAFT

VI

DEPARTMENT OF THE AIR FORCE
Air Force Institute of Technology (AU)
Wright-Patterson AFB OH 45433-6583

AFIT REGULATION 700-xx

4 Sep 91

Maintaining the AFIT Database

This regulation establishes policy and responsibility for maintaining the information in the Air Force Institute of Technology (AFIT) Management Information System (MIS) database and applies to all schools, directorates, and staff agencies of AFIT located at Wright-Patterson AFB.

1. General: The AFIT MIS is a collection of interrelated software applications which uses a centralized database, designed to meet the varied information needs of the Institute. It is incumbent on each office that uses the database to keep the information complete and accurate at all times.

2. Policy: The AFIT MIS will be used to maintain data, perform functions, and generate reports related to management of AFIT's resident graduate education and Civilian Institution Programs. The MIS will be the primary focus for student information from selection to graduation. The database will maintain information concerning student, faculty and staff personnel.

3. Responsibilities: All offices that use the database shall share the responsibility of keeping the information complete and accurate. This regulation will define in general terms where the responsibility lies for most student related information. Attachments 1 and 2 establish data requirements and the Offices of Primary Responsibility (OPRs) for information updates.

a. The Communications-Computer Systems Directorate, SC.

(1) SC will have ultimate responsibility for the database and applications used to manipulate the data. A project manager will oversee the development of applications that are able to change data in the database.

(2) At the discretion of the project manager, other applications may have access to the database in a read only environment.

b. Directorates. The following directorates will establish internal procedures to insure that data used by their functions are maintained accurately and completely. Attachments 1 and 2 will be

No. of Printed Pages: 25

OPR: SCV (Capt Auzenne)

Approved by: Maj Gordon D. Wishon

Distribution: F, X (AU/SCX - 1, AU/SCV - 1)

DRAFT

2 AFITR 700-xx, 4 Sep 91

the guide to establishing the OPRs for all data in the AFIT database. SC will review all accesses to insure conflicts do not arise.

(1) Evaluation and Admissions Division (RRE) is responsible for initially inputting data on all students selected for an AFIT educational program.

(2) Scheduling And Registration (RRDS) will be responsible for updating any information related to student enrollment and AFIT's academic environment using AFIT Student Information System (AFITSIS) applications.

(3) The Squadron Section Commander (CCQ) will be responsible for maintaining information concerning faculty and staff members, personal information on students enrolled in an AFIT resident program (AFITSIS), and other information related to Air Force programs.

(4) The resident schools (ENA, LSA, and DEV) will be responsible for school related validation and student career information (AFITSIS).

(5) Departments of each resident school will be responsible for establishing course offering and graduation standards, and student education planning (AFITSIS).

(6) Civilian Institutions (CI) personnel are responsible for all information concerning students enrolled in Civilian Institution Regular, Health, and Special programs using Management Information Financial Forecasting System (MIFFS) applications.

(7) Directorate of Resource Management Finance Branch (ACF) is responsible for information concerning management of funds for tuition, fees, etc. for students enrolled in Civilian Institutions Programs (MIFFS). These functions are yet to be implemented in MIFFS.

4. Revisions/updates: Revisions and updates to this regulation will be made as new capabilities are developed or whenever functional responsibilities change, on an as required basis.

OFFICIAL

FREDERICK C. BAUER, Colonel, USAF
Commandant

2 Atch

1. AFITSIS Field OPRs
2. MIFFS Field OPRs

AFITSIS Field OPRs

User Classes

AFITSIS User Categories

Registrar	(RRDS)	SRSRRDS
School Administration	(ADMIN)	SRSENA, SRSLSG, SRSDEV
	(ADMINLD)	SRSLSG, SRSDEV
	(ADMINEN)	SRSENA
	(ADMINLS)	SRSLSG
	(ADMINC)	School owning the course
	(ADMINS)	School owning the student
	(ADMINP)	School owning the program
	(ADMINE)	School owning the specialty edplan
Orderly Room	(CCQ)	SRSCCQ
Quota Book	(RRE)	SRSRRE
International Students	(RRI)	SRSRRI
School Departments	(DEPT)	SRSENC, SRSENG, SRSENP, SRSENS, SRSENR, SRSENY, SRSLSA, SRSLSC, SRSLSG, SRSLSL, SRSLSM, SRSLSQ, SRLSLR, SRLSLY
	(DEPTC)	Department owning the course
	(DEPTS)	Department owning the student
	(DEPTP)	Department owning the program
	(DEPTE)	Dept owning the specialty edplan
	(DEPTEN)	Any EN Department
AFIT Personnel System	(APS)	AFITAC, AFITCC, AFITCCQ, AFITCI, AFITDP, AFITEN, AFITENA, AFITENC, AFITENG, AFITENP, AFITENS, AFITENY, AFITIM, AFITLD, AFITLS, AFITLSA, AFITLSG, AFITLSL, AFITLSM, AFITLSP, AFITLSQ, AFITLSR, AFITLSY, AFITPA, AFITRM, AFITRR, AFITRRR, AFITSC, AFITXP, SC
MIFFS	(MIFFS)	ACES, ACF, CI, CIA, CIB, CIM, CIME, CIMJ, CIR, CIRD, CIRG, CIRK, CISC, CISH, CISP, CISS, MIFFS

4 AFITR 700-xx, Attachment 1, 4 Sep 91

Function : Insert a new person into AFIT Database

- 1) Insert a full-time student
Form : Selected Student Data (SELECTION)
OPR : RRE
- 2) Insert a part-time student
Form : Personal Information (ADMISSION)
OPR : RRDS
- 3) Insert an international student
Form : Applications and Evaluations (INTL_EVALUATION)
OPR : RRI
- 4) Insert an international sponsor
Form : Sponsor Information (INTL_SPONSOR_DATA)
OPR : RRI
- 5) Insert staff/faculty
Form : Find/Update Personnel Information (PMS_INFO)
OPR : APS

Function : Update personal information

- 1) Form : Selected Student Data (SELECTION)
OPR : RRE
- 2) Form : Personal Information (ADMISSION)
OPR : RRDS
- 3) Form : Applications and Evaluations (INTL_EVALUATION)
OPR : RRI
- 4) Form : Sponsor Information (INTL_SPONSOR_DATA)
OPR : RRI
- 5) Form : International Student Information (INTL_STUDENT_DATA)
OPR : RRI
- 6) Form : Family Information (FAMILY_INFORMATION)
OPR : RRI
- 7) Form : Find/Update Personnel Information (PMS_INFO)
OPR : APS
- 8) Form : CCQ Data Entry Screen (CCQ_DATA_ENTRY)
OPR : CCQ
- 9) Form : Student Demographics (STUDENT_DEMOGRAPHICS)
OPR : ADMINIS

- 10) Form : Dependent Information (DEPENDENT_INFORMATION)
OPR : ADMINS

Function : Change a person's name

- 1) Form : Change a Person's Name (NAME_HIST)
OPR : RRDS, RRE

Function : Change a SSAN

- 1) Form : Change a Person's SSAN (SSAN_UPDATE)
OPR : RRDS, RRE

Function : Delete a person from AFIT Database

- 1) Form : None
OPR : None
Fields : None

Function : Insert into validation tables

- 1) Form : All validation forms
Note : Refer to the validation tables addendum

Function : Address information

- 1) Form : Address Information (ADDRESS_DATA)
OPR : ADMINS, CCQ, RRDS, RRI
2) Form : Find/Update Address and Locator Information (PMS_ADD)
OPR : APS

Function : AFITNET Username

- 1) Form : CCQ Data Entry (CCQ_DATA_ENTRY)
OPR : CCQ
2) Form : Resident Student Information (VIEW_RESIDENT_SCHOOL_INPUT)
OPR : ADMINS

Function : AFIT course catalog

- 1) Form : Course Catalog (COURSE_CATALOG)
OPR : RRDS
2) Form : Course Prerequisites (PREREQ_MAINTENANCE)
OPR : RRDS
3) Form : Course Corequisites (COREQ_MAINTENANCE)
OPR : RRDS

6 AFITR 700-xx, Attachment 1, 4 Sep 91

Function : Submit Form 51 to change the AFIT course catalog

- 1) Form : New Course Entry (NEW_COURSES)
OPR : DEPTC

Function : Create and update the course schedule

- 1) Form : Rollover Courses from Offerings (ROLLOVER_FROM_OFFERINGS)
OPR : RRDS
- 2) Form : Rollover Single Course from Catalog (ROLLOVER_SINGLE_COURSE)
OPR : RRDS
- 3) Form : Create Course Sections (CREATE_COURSE_SECTIONS)
OPR : RRDS
- 4) Form : Schedule Course Times (SCHEDULE_COURSE_TIMES)
OPR : RRDS
- 5) Form : Modify Schedule Notes (SCHEDULE_NOTES)
OPR : RRDS
- 6) Form : Modify Schedule Room Requirements (SCHEDULE_ROOM_REQUIREMENTS)
OPR : RRDS
- 7) Form : School Schedule Course Times (SCHOOL_SCHEDULE_TIMES)
OPR : ADMINC
- 8) Form : Delete Vacant Courses (DELETE_UNREG_COURSES)
OPR : RRDS

Function : Submit course offerings

- 1) Form : Course Offerings (COURSE_OFFERINGS)
OPR : DEPTC, ADMINC, RRDS
- 2) Form : Rollover Course Offerings (ROLLOVER_OFFERINGS)
OPR : DEPTC, ADMINC, RRDS
- 3) Form : Course Offerings Remarks (COURSE_OFFERINGS_REMARKS)
OPR : DEPTC, ADMINC, RRDS
- 4) Form : Change Course Offering Status (COURSE_CANCELLATION)
OPR : DEPTC, ADMINC, RRDS

- 5) Form : Request Department to Offer Course
(DEPARTMENT_REQUEST_COURSE)
OPR : DEPTC, ADMIN

Function : Graduation

- 1) Form : Graduation Candidates by Term (GRADUATION)
OPR : RRDS
- 2) Form : Award Double Degrees (DOUBLE_DEGREE)
OPR : RRDS
- 3) Form : CST Certification (CST_CERTIFICATION)
OPR : RRDS
- 4) Form : PSE Certification (PSE_CERTIFICATION)
OPR : RRDS
- 5) Form : Reactivate Graduated Student (UNGRADUATE)
OPR : RRDS

Function : Dependents information

- 1) Form : CCQ Data Entry (CCQ_DATA_ENTRY)
OPR : CCQ
- 2) Form : Dependent Information (DEPENDENT_INFORMATION)
OPR : ADMINS
- 3) Form : Student Demographics (STUDENT_DEMOGRAPHICS)
OPR : ADMINS

Function : Duty history

- 1) Form : Duty History Information (DUTY_HISTORY)
OPR : ADMINS
- 2) Form : Student Demographics (STUDENT_DEMOGRAPHICS)
OPR : ADMINS
- 3) Form : CCQ Data Entry (CCQ_DATA_ENTRY)
OPR : CCQ
- 4) Form : Gaining and Losing Duty Information (BASE_MAJCOM_INFORMATION)
OPR : ADMINS
- 5) Form : Gaining and Losing Duty Information for Graduated Students (GRAD_BASE_MAJCOM_INFORMATION)
OPR : ADMINS

Function : Student edplan related information

- 1) Form : Enter a Student's Edplan Comments (EDPLAN_DESC)
OPR : ADMINS, DEPTS
- 2) Form : Thesis Information (THESIS_INFORMATION)
OPR : RRDS, ADMINS, DEPTS
- 3) Form : Create Specialty Edplans (CREATE_SPECIALTY_EDPLAN)
OPR : ADMINLD, DEPTE
- 4) Form : Assign Specialty Edplan to Students (REGISTRATION_BY_SPEC_EDPLAN)
OPR : DEPTS
- 5) Form : Create program Edplan (PROGRAM_PLAN)
OPR : DEPTP
- 6) Form : Rollover Program Edplan (ROLLOVER_EDPLAN)
OPR : ADMIN, DEPT
- 7) Form : Rollover Program Edplan by Quarter (ROLLOVER_EDPLAN_BY_QUARTER)
OPR : DEPT
- 8) Form : Assign Program Edplan to Students (ASSIGN_EDPLANS)
OPR : DEPTP
- 9) Form : Register a Student for Courses (SCHOOL_REGISTRATION)
OPR : DEPTS
- 10) Form : Record of Non-AFIT Courses (TRANSFER_CREDITS)
OPR : RRDS
- 11) Form : Drop or Add to Student Schedule (RRDS_SCHEDULING)
OPR : RRDS
- 12) Form : Change Students Credit Hours for a Course (CHANGE_CREDIT_ROSTER)
OPR : RRDS
- 13) Form : Register Students (REGISTRATION_ROSTER)
OPR : RRDS
- 14) Form : Student Maintenance (CHANGE_GRADE)
OPR : RRDS

- 15) Form : Enter a Student's Major(s) and Option(s)
(MAJORS_OPTIONS)
OPR : DEPTS, ADMINS

Function : Education history

- 1) Form : Educational Background (ED_HIST)
OPR : RRDS
- 2) Form : Student's educational Background
(SCHOOL_EDUCATION_HISTORY)
OPR : ADMINS, DEPTS
- 3) Form : Applications and Evaluations (INTL_EVALUATION)
OPR : RRI
- 4) Form : Graduation Candidates by Term (GRADUATION)
OPR : RRDS
- 5) Form : Reactivate Graduated Student (UNGRADUATE)
OPR : RRDS

Function : Exam scheduling

- 1) Form : Schedule Exam Times (SCHEDULE_EXAM_TIMES)
OPR : RRDS

Function : Fitness test results

- 1) Form : Weigh-in/Aerobics (WEIGH_IN_AEROBICS)
OPR : CCQ

Function : Entering graduating students' grades

- 1) Form : Graduating Students' Grades (GRAD_GRADES_ROSTER)
OPR : ADMINLS, DEPTS, RRDS

Function : Entering non-graduating students' grades

- 1) Form : student Grades by Course (GRADE_ROSTER)
OPR : RRDS
- 2) Form : Student Maintenance (CHANGE_GRADE)
OPR : RRDS
- 3) Form : Course Grade Maintenance (CHANGE_GRADE_ROSTER)
OPR : RRDS

10 AFITR 700-xx, Attachment 1, 4 Sep 91

Function : Drop and add

- 1) Form : Drop or Add to Student Schedule (RRDS_SCHEDULING)
OPR : RRDS

**Function : Student's AFIT transcript and degree related information
(excluding registration, graduation and grades)**

- 1) Form : Enter a Student's Major(s) and Options(s) (MAJORS_OPTIONS)
OPR : DEPTS, ADMINS
- 2) Form : Admission (ADMISSION)
OPR : RRDS
- 3) Form : Educational Background (ED_HIST)
OPR : RRDS
- 4) Form : Student's Educational Background (SCHOOL_EDUCATION_HISTORY)
OPR : ADMINS, DEPTS
- 5) Form : Applications and Evaluations (INTL_EVALUATION)
OPR : RRI
- 6) Form : Thesis Information (THESIS DISSERTATION)
OPR : RRDS, DEPTS, ADMINS

Function : Student's AFIT related information

- 1) Form : Resident Student Information (VIEW_RESIDENT_SCHOOL_INPUT)
OPR : ADMINS, DEPTS
- 2) Form : Admission (ADMISSION)
OPR : RRDS
- 3) Form : Assign Program Sections and Leader positions (PROGRAM_SECTION_ASSIGNMENTS)
OPR : ADMINS
- 4) Form : Change a Student's Registration Department (CHANGE_STUDENT_REGS_DEPT)
OPR : DEPTS
- 5) Form : Box Number Assignments (BOX_NUMBER_ASSIGNMENTS)
OPR : CCQ
- 6) Form : CCQ Data Entry (CCQ_DATA_ENTRY)
OPR : CCQ

AFITR 700-xx, Attachment 1, 4 Sep 91 11

- 7) Form : Student Demographics (STUDENT_DEMOGRAPHICS)
OPR : ADMINS
- 8) Form : Section Leader Assignments (SECTION_LEADER_ASSIGNMENTS)
OPR : CCQ
- 9) Form : Program Advisor Assignments (ASSIGN_PROGRAM_ADVISOR)
OPR : CCQ, DEPTP
- 10) Form : Locker Number Assignments (LOCKER_ASSIGNMENTS)
OPR : CCQ
- 11) Form : Building Access Card Assignments (BUILDING_ACCESS_CARDS)
OPR : CCQ
- 12) Form : Change a Person's Rank (RANK_HIST)
OPR : CCQ, RRDS, RRE
- 13) Form : Weigh In/Aerobics (WEIGH_IN_AEROBICS)
OPR : CCQ
- 14) Form : Weight Management Program (WEIGHT_MANAGEMENT_PROGRAM)
OPR : CCQ
- 15) Form : Assign Duty (ASSIGN_DUTY)
OPR : CCQ
- 16) Form : Security Access Badge Assignments (BADGE_NUMBERS)
OPR : CCQ
- 17) Form : Delete Badges for Graduating Students (DELETE_BADGES)
OPR : CCQ

Function : Additional duties

- 1) Form : Assign Duty (ASSIGN_DUTY)
OPR : CCQ

Function : Academic advisor assignments

- 1) Form : Assign Academic Advisors by Program/ASC (ASSIGN_ACADEMIC_ADVISOR)
OPR : ADMINS, DEPTS

12 AFITR 700-xx, Attachment 1, 4 Sep 91

- 2) Form : Assign Student an Academic Advisor
(FACULTY_ADVISOR)
OPR : ADMINS, DEPTS
- 3) Form : Resident Student Information
(VIEW_RESIDENT_SCHOOL_INPUT)
OPR : ADMINS, DEPTS

Function : Security Badges

- 1) Form : Security Access Badge Assignments
(BADGE_NUMBERS)
OPR : CCQ
- 2) Form : Delete Badges for Graduating Students
(DELETE_BADGES)
OPR : CCQ

Function : IMT information

- 1) Form : Applications and Evaluations (INTL_EVALUATION)
OPR : RRI
- 2) Form : International Student Information
(INTL_STUDENT_DATA)
OPR : RRI
- 3) Form : Assign Student an Academic Advisor
(FACULTY_ADVISOR)
OPR : ADMINS, DEPTS, RRI
- 4) Form : Sponsor Information (INTL_SPONSOR_DATA)
OPR : RRI
- 5) Form : Family Information (FAMILY_INFORMATION)
OPR : RRI
- 6) Form : Address Information (ADDRESS_DATA)
OPR : ADMINS, CCQ, RRDS, RRI
- 7) Form : Informational Program resources (RESOURCES)
OPR : RRI
- 8) Form : Informational Program Attendance (IP_ATTENDANCE)
OPR : RRI
- 9) Form : Informational Program Assessment (IP_ASSESSMENTS)
OPR : RRI

Function : Program edplans

- 1) Form : Create Program Edplan (PROGRAM_PLAN)
OPR : DEPTP
- 2) Form : Rollover Program Edplan (ROLLOVER_EDPLAN)
OPR : ADMIN, DEPT
- 3) Form : Rollover Program Edplan by Quarter (ROLLOVER_EDPLAN_BY_QUARTER)
OPR : ADMIN, DEPT

Function : Registration by program edplan

- 1) Form : Assign Program Edplan to Students (ASSIGN_EDPLANS)
OPR : DEPTP

Function : Program Sections

- 1) Form : Assign Program Edplan to Students (PROGRAM_SECTION_ASSIGNMENTS)
OPR : ADMINS
- 2) Form : Section Leader Assignments (SECTION_LEADER_ASSIGNMENTS)
OPR : CCQ

Function : Program sequence edplans

- 1) Form : Create Specialty Edplans (CREATE_SPECIALTY_EDPLAN)
OPR : DEPTE, ADMINLD

Function : Registration by program sequence edplan

- 1) Form : Assign Specialty Edplan to Students (ASSIGN_BY_SPEC_EDPLAN)
OPR : DEPTE

Function : Section Leaders

- 1) Form : Assign Program Sections and Leader Positions (PROGRAM_SECTION_ASSIGNMENTS)
OPR : ADMINS
- 2) Form : Section Leader Assignments (SECTION_LEADER_ASSIGNMENTS)
OPR : CCQ

Function : Spouse Information

- 1) Form : Sponsor Information (INTL_SPONSOR_DATA)
OPR : RRI
- 2) Form : Find/Update Personnel Information (PMS_INFO)
OPR : APS
- 3) Form : Family Information (FAMILY_INFORMATION)
OPR : RRI
- 4) Form : CCQ Data Entry (CCQ_DATA_ENTRY)
OPR : CCQ
- 5) Form : Student Demographics (STUDENT_DEMOGRAPHICS)
OPR : ADMINS
- 6) Form : Dependent Information (DEPENDENT_INFORMATION)
OPR : ADMINS

Function : National entrance test scores

- 1) Form : Test Scores (TEST_SCORES)
OPR : RRDS
- 2) Form : Statistical Data (STATS)
OPR : RRE
- 3) Form : Applications and Evaluations (INTL_EVALUATION)
OPR : RRI

Function : Transfer and SOCHE course

- 1) Form : Record of Non-AFIT Course(s) (TRANSFER_CREDITS)
OPR : RRDS

Function : Department Head

- 1) Form : Update Department Data (DEPARTMENT_UPDATE)
OPR : ADMINS

Function : Weight management program

- 1) Form : Weigh In/Aerobics (WEIGH_IN_AEROBICS)
OPR : CCQ
- 2) Form : Weight Management Program (WEIGHT_MANAGEMENT_PROGRAM)
OPR : CCQ

Function : Department of registration

- 1) Form : Student Demographics (STUDENT_DEMOGRAPHICS)
OPR : ADMINS
- 2) Form : Admission (ADMISSION)
OPR : RRDS
- 3) Form : Change a Student's Program (PROGRAM_HIST)
OPR : RRDS
- 4) Form : Change a Student's Registration Department
(CHANGE_STUDENT_REGS_DEPT)
OPR : DEPTS

Function : Emergency contact

- 1) Form : Emergency Contact Information
(EMERGENCY_CONTACT)
OPR : RRDS, ADMINS
- 2) Form : CCQ Data Entry (CCQ_DATA_ENTRY)
OPR : CCQ
- 3) Form : Student Demographics (STUDENT_DEMOGRAPHICS)
OPR : ADMINS

Function : Change a person's rank

- 1) Form : Admission (ADMISSION)
OPR : RRDS
- 2) Form : Change a Person's Rank (RANK_HIST)
OPR : RRDS, CCQ, RRE

Function : Change a student's program

- 1) Form : Admission (ADMISSION)
OPR : RRDS
- 2) Form : Change a Student's Program (PROGRAM_HIST)
OPR : RRDS

Function : Change a grade

- 1) Form : Record of Non-AFIT Courses (TRANSFER_CREDITS)
OPR : RRDS
- 2) Form : Student Maintenance (CHANGE_GRADE)
OPR : RRDS

16 AFITR 700-xx, Attachment 1, 4 Sep 91

- 3) Form : Student Grades by Course (GRADE_ROSTER)
OPR : RRDS
- 4) Form : Course Grade Maintenance (CHANGE_GRADE_ROSTER)
OPR : RRDS
- 5) Form : Graduating Students' Grades (GRAD_GRADES_ROSTER)
OPR : DEPTS

Function : Change credit hours for a course

- 1) Form : Register a Student for Courses (SCHOOL_REGISTRATION)
OPR : DEPTS
- 2) Form : Record of Non-AFIT Courses (TRANSFER_CREDITS)
OPR : RRDS
- 3) Form : Drop or Add to Student Schedule (RRDS_SCHEDULING)
OPR : RRDS
- 4) Form : Change Students' Credit Hours for a Course (CHANGE_CREDIT_ROSTER)
OPR : RRDS

Function : Single course registration

- 1) Form : Drop or Add to Student Schedule (RRDS_SCHEDULING)
OPR : RRDS

Function : Reactivate a graduated student

- 1) Form : Reactivate Graduated Student (UNGRADUATE)
PR : RRDS

Function : PSE and CST Certification

- 1) Form : PSE Certification (PSE_CERTIFICATION)
OPR : RRDS
- 2) Form : CST Certification (CST_CERTIFICATION)
OPR : RRDS

Function : Delete a resident student

- 1) Form : Delete Resident Student (DELETE_RESIDENT)
OPR : RRDS

Function : Insert a new course into the course catalog

- 1) Form : Insert New Course into Course Catalog (INSERT_NEW_COURSE)
OPR : RRDS

Function : Assign instructors to courses

- 1) Form : Assign Instructor's Courses (INSTRUCTORS_COURSES)
OPR : RRDS

Function : Change a student's graduation date

- 1) Form : Change a Student's Graduation Date (GRAD_HIST)
OPR : RRDS

Function : Delete a selected student

- 1) Form : Delete Selected Student (DELETE_SELECTED)
OPR : RRE

Function : Archive Quota Book information

- 1) Form : Archive Quota Book Information (ARCHIVE_QUOTA)
OPR : RRE

MIFFS Field OPRs

User Classes

MIFFS User Categories

CI System Administrator	(SYS_ADMIN)	
Quota Book	(RRE)	RRE
MIFFS	(ACES)	ACES
	(ACF)	ACF
	(CI)	CI
	(CIA)	CIA
	(CIB)	CIB
	(CIM)	CIM
	(CIME)	CIME
	(CIMJ)	CIMJ
	(CIMI)	CIMI
	(CIR)	CIR
	(CIRD)	CIRD
	(CIRG)	CIRG
	(CIRK)	CIRK
	(CISC)	CISC
	(CISH)	CISH
	(CISP)	CISP
	(CISS)	CISS
	(MIFFS)	MIFFS
	(CI_MED)	CIM, CIMI, CIMJ
	(CI_PM)	CIM, CIMI, CIMJ, CIR, CIRD, CIRG, CIRK, CISC, CISH, CISS, CISP

- Function : Insert a new person into ACES
Form : PERSON
OPR : RRE, CI_PM
- Function : Update an existing person in ACES
Form : PERSON
OPR : CI_PM (PM may only update own students)
- Function : Insert a Book Allowance Entry for a Student
Form : BOOK_ALLOWANCE_QUARTERS
OPR : SYS_ADMIN
- Function : Update a Book Allowance Entry for a Student
Form : BOOK_ALLOWANCE_QUARTERS
OPR : SYS_ADMIN
- Function : Print the Annual Book Allowance Roster
Form : PRINT_ANNUAL_BOOK_ROSTER
OPR : SYS_ADMIN
- Function : Print the Quarterly Book Allowance Roster
Form : PRINT_QUARTERLY_BOOK_ROSTER
OPR : SYS_ADMIN
- Function : Print the Annual Book Roster for the Finance Office
Form : PRINT_FIN_BOOK_ROSTER_ANNUAL
OPR : ACF
- Function : Print the Quarterly Book Roster for the Finance Office
Form : PRINT_FIN_BOOK_ROSTER_QUARTER
OPR : ACF
- Function : Insert Thesis/Dissertation Information for a Student
Form : THESIS DISSERTATION
OPR : CIM, CIMI, CIR, CIRD, CIRK, CISP, CISS
- Function : Update Thesis/Dissertation Information for a Student
Form : THESIS DISSERTATION
OPR : CIM, CIMI, CIR, CIRD, CIRK, CISP, CISS
- Function : Delete Thesis/Dissertation Information for a Student
Form : THESIS DISSERTATION
OPR : CIM, CIMI, CIR, CIRD, CIRK, CISP, CISS
- Function : Insert HPSP ADT Information for a Student
Form : HPSP_STUDENT_ACTIVE_DUTY_TOUR
OPR : CIMJ
- Function : Update HPSP ADT Information for a Student
Form : HPSP_STUDENT_ACTIVE_DUTY_TOUR
OPR : CIMJ

20 AFITR 700-xx, Attachment 2, 4 Sep 91

Function : Delete HPSP ADT Information for a Student
Form : HPSP_STUDENT_ACTIVE_DUTY_TOUR
OPR : CIMJ

Function : Insert an HPSP ADT Deferral for a Student
Form : HPSP_ADT_DEFERRAL
OPR : CIMJ

Function : Update an HPSP ADT Deferral for a Student
Form : HPSP_ADT_DEFERRAL
OPR : CIMJ

Function : Insert a new HPSP ADT Course
Form : ENTER_HPSP_ADT_COURSE_INFO
OPR : CIMJ

Function : Update an HPSP ADT Course
Form : ENTER_HPSP_ADT_COURSE_INFO
OPR : CIMJ

Function : Insert Medical Education Director Information
Form : MEDICAL_EDUCATION_DIRECTOR
OPR : CIMJ

Function : Update Medical Education Director Information
Form : MEDICAL_EDUCATION_DIRECTOR
OPR : CIMJ

Function : Delete Medical Education Director Information
Form : MEDICAL_EDUCATION_DIRECTOR
OPR : CIMJ

Function : Insert an Address for a Student
Form : ADDRESS_DATA
OPR : CI_PM
Fields :

Function : Update an Address for a Student
Form : ADDRESS_DATA
OPR : CI_PM

Function : Delete an Address for a Student
Form : ADDRESS_DATA
OPR : CI_PM

Function : Insert Spouse Information for a Student
Form : SPOUSE
OPR : CI_PM, CIA

Function : Update Spouse Information for a Student
Form : SPOUSE
OPR : CI_PM, CIA

- Function : Delete Spouse Information for a Student
Form : SPOUSE
OPR : CI_PM, CIA
- Function : Insert Dependent Information for a Student
Form : DEPENDENT
OPR : CI_PM, CIA
- Function : Update Dependent Information for a Student
Form : DEPENDENT
OPR : CI_PM, CIA
- Function : Delete Dependent Information for a Student
Form : DEPENDENT
OPR : CI_PM, CIA
- Function : Insert Prior Military Service Information for a Student
Form : PRIOR_MILITARY_SERVICE
OPR : CI_PM (except CISC)
- Function : Update Prior Military Service Information for a Student
Form : PRIOR_MILITARY_SERVICE
OPR : CI_PM (except CISC)
- Function : Delete Prior Military Service Information for a Student
Form : PRIOR_MILITARY_SERVICE
OPR : CI_PM (except CISC)
- Function : Insert Clearance Information for a Student
Form : CLEARANCE
OPR : CIA
- Function : Update Clearance Information for a Student
Form : CLEARANCE
OPR : CIA
- Function : Delete Clearance Information for a Student
Form : CLEARANCE
OPR : CIA
- Function : Insert Submittal Information for a Student
Form : STUDENT_SUBMITTAL
OPR : CI_PM, CIA
- Function : Update Submittal Information for a Student
Form : STUDENT_SUBMITTAL
OPR : CI_PM, CIA
- Function : Delete Submittal Information for a Student
Form : STUDENT_SUBMITTAL
OPR : CI_PM, CIA

22 AFITR 700-xx, Attachment 2, 4 Sep 91

Function : Change a Student's Rank

Form : RANK_HIST
OPR : CI_PM

Function : Change a Student's Name

Form : NAME_HIST
OPR : CI_PM

Function : Insert National Test Scores for a Student

Form : TEST_SCORES
OPR : CI_PM, RRE

Function : Update National Test Scores for a Student

Form : TEST_SCORES
OPR : CI_PM, RRE

Function : Delete National Test Scores for a Student

Form : TEST_SCORES
OPR : CI_PM, RRE

Function : Place a Student in the Weight Management Program

Form : WEIGHT_MGMT_PROGRAM
OPR : CIA

Function : Update Information on Student in the Weight Management Program

Form : WEIGHT_MGMT_PROGRAM
OPR : CIA

Function : Delete Information on Student in the Weight Management Program

Form : WEIGHT_MGMT_PROGRAM
OPR : CIA

Function : Insert a Student into the Nomogram Program

Form : NOMOGRAM_PROGRAM
OPR : CIA

Function : Update a Student in the Nomogram Program

Form : NOMOGRAM_PROGRAM
OPR : CIA

Function : Delete a Student from the Nomogram Program

Form : NOMOGRAM_PROGRAM
OPR : CIA

Function : Insert a Student as a Liaison Officer

Form : LIAISON_OFFICER
OPR : CIA

Function : Delete Liaison Officer Information
Form : LIAISON_OFFICER
OPR : ACES

Institution Related Functions

Function : Insert a Civilian Institution
Form : CIVILIAN_INSTITUTION
OPR : CIA

Function : Update a Civilian Institution
Form : CIVILIAN_INSTITUTION
OPR : CIA

Function : Insert a Civilian Institution Point-of-Contact
Form : CIV_INS_POINT_OF_CONTACT
OPR : CI_PM, ACF, CIA, CI

Function : Update a Civilian Institution Point-of-Contact
Form : CIV_INS_POINT_OF_CONTACT
OPR : CI_PM, ACF, CIA, CI

Function : Delete a Civilian Institution Point-of-Contact
Form : CIV_INS_POINT_OF_CONTACT
OPR : CI_PM, ACF, CIA, CI

Function : Insert Residency Information for a Civilian Institution
Form : CIV_INS_RESIDENCY_GRANTED
OPR : CI_PM

Function : Update Residency Information for a Civilian Institution
Form : CIV_INS_RESIDENCY_GRANTED
OPR : CI_PM

Function : Delete Residency Information for a Civilian Institution
Form : CIV_INS_RESIDENCY_GRANTED
OPR : CI_PM

Function : Insert University Visit/Drug Test Information for a
Civilian Institution
Form : UNIV_VISITS_DRUG_TESTS
OPR : CI, CIA

Function : Update University Visit/Drug Test Information for a
Civilian Institution
Form : UNIV_VISITS_DRUG_TESTS
OPR : CI, CIA

Function : Insert EWI Company Coordinator Information for an EWI
Site (Civilian Institution)
Form : EWI_COMPANY_COORDINATOR
OPR : CISH

Function : Update EWI Company Coordinator Information for an EWI
Site (Civilian Institution)
Form : EWI_COMPANY_COORDINATOR
OPR : CISH

Function : Insert Medical Program Director Information for a
Hospital (Civilian Institution)
Form : MEDICAL_PROGRAM_DIRECTOR
OPR : CIM

Function : Update Medical Program Director Information for a
Hospital (Civilian Institution)
Form : MEDICAL_PROGRAM_DIRECTOR
OPR : CIM

Function : Delete Medical Program Director Information for a
Hospital (Civilian Institution)
Form : MEDICAL_PROGRAM_DIRECTOR
OPR : CIM

Function : Insert CBPO Information
Form : CBPO
OPR : CIA

Function : Update CBPO Information
Form : CBPO
OPR : CIA

Function : Delete CBPO Information
Form : CBPO
OPR : CIA

Function : Insert ROTC Detachment Information
Form : ROTC_DETACHMENT
OPR : CIA

Function : Update ROTC Detachment Information
Form : ROTC_DETACHMENT
OPR : CIA

Function : Delete ROTC Detachment Information
Form : ROTC_DETACHMENT
OPR : CIA

Function : Insert Medical Support Unit Information
Form : MEDICAL_SUPPORT_UNIT
OPR : CIA

Function : Update Medical Support Unit Information
Form : MEDICAL_SUPPORT_UNIT
OPR : CIA

Function : Delete Medical Support Unit Information
Form : MEDICAL_SUPPORT_UNIT
OPR : CIA

Function : Change a Student's SSAN
Form : SSAN_UPDATE
OPR : CIA

Function : Insert a Default Printer for an AFIT Office
Form : DEFAULT_PRINTER
OPR : All ACES Users

Function : Update a Default Printer for an AFIT Office
Form : DEFAULT_PRINTER
OPR : All ACES Users

Function : Delete a Default Printer for an AFIT Office
Form : DEFAULT_PRINTER
OPR : All ACES Users

REPORT DOCUMENTATION PAGE

Form Approved
OMB No. 0704-0188

Public reporting burden for this collection of information is estimated to average 1 hour per response, including the time for reviewing instructions, searching existing data sources, gathering and maintaining the data needed, and completing and reviewing the collection of information. Send comments regarding this burden estimate or any other aspect of this collection of information, including suggestions for reducing this burden, to Washington Headquarters Services, Directorate for Information Operations and Reports, 1215 Jefferson Davis Highway, Suite 1204, Arlington, VA 22202-4302, and to the Office of Management and Budget, Paperwork Reduction Project (0704-0188), Washington, DC 20503.

1. AGENCY USE ONLY (Leave blank)	2. REPORT DATE March 1996	3. REPORT TYPE AND DATES COVERED Final
---	-------------------------------------	--

4. TITLE AND SUBTITLE AIR FORCE INSTITUTE OF TECHNOLOGY: ANALYSIS OF INFORMATION NEEDS AND CAPABILITIES	5. FUNDING NUMBERS
---	---------------------------

6. AUTHOR(S) Associate Professor Alan Heminger (and list of students on page 1)	
---	--

7. PERFORMING ORGANIZATION NAME(S) AND ADDRESS(ES) Air Force Institute of Technology Graduate School of Acquisition & Logistics Management Wright-Patterson AFB, OH 45433-7765	8. PERFORMING ORGANIZATION REPORT NUMBER AFIT-LA-TR-96-1
--	--

9. SPONSORING / MONITORING AGENCY NAME(S) AND ADDRESS(ES) Same as #7.	10. SPONSORING / MONITORING AGENCY REPORT NUMBER
---	---

11. SUPPLEMENTARY NOTES

12a. DISTRIBUTION / AVAILABILITY STATEMENT Unlimited Distribution	12b. DISTRIBUTION CODE
---	-------------------------------

13. ABSTRACT (Maximum 200 words)

An analysis of the information needs and capabilities of the Air Force Institute of Technology identified a number of problems with its information systems and the associated data stores.

14. SUBJECT TERMS Information Architecture, Information Management, Information Resource Management	15. NUMBER OF PAGES 102
	16. PRICE CODE

17. SECURITY CLASSIFICATION OF REPORT UNCLASSIFIED	18. SECURITY CLASSIFICATION OF THIS PAGE UNCLASSIFIED	19. SECURITY CLASSIFICATION OF ABSTRACT UNCLASSIFIED	20. LIMITATION OF ABSTRACT UL
--	---	--	---