

Commercial Standard **CS272-65**

Polyvinyl Chloride (PVC) Plastic Drain, Waste, and Vent Pipe and Fittings

A recorded
voluntary standard of the
trade published by
the U.S. Department
of Commerce



19960628 098

NON STATEMENT A
a for public release
Unlimited

DTIC QUALITY INSPECTED 1

For sale by the Superintendent of Documents
U.S. Government Printing Office, Washington, D.C., 20402 - Price 15 cents

PLASTICS TECHNICAL EVALUATION CENTER
PICATINNY ARSENAL, DOVER, N. J.

PLASTIC 10620

DISCLAIMER NOTICE

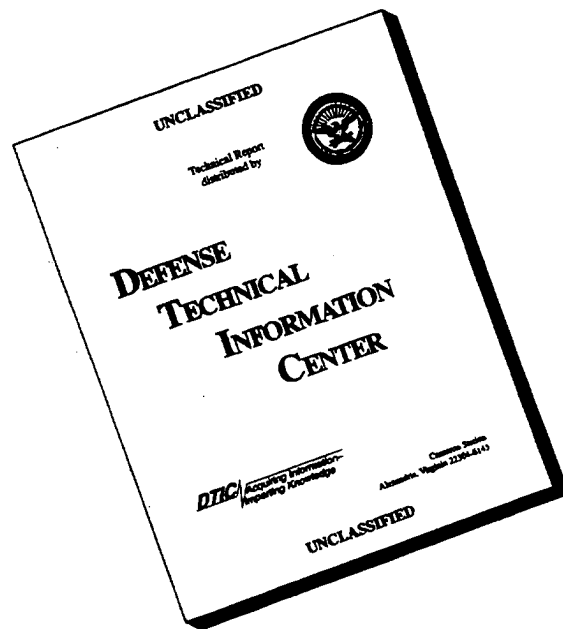

THIS DOCUMENT IS BEST QUALITY AVAILABLE. THE COPY FURNISHED TO DTIC CONTAINED A SIGNIFICANT NUMBER OF PAGES WHICH DO NOT REPRODUCE LEGIBLY.

U.S. DEPARTMENT OF COMMERCE
NATIONAL BUREAU OF STANDARDS
Office of Commodity Standards

EFFECTIVE DATE

Having been passed through the regular procedures of the Office of Commodity Standards (formerly the Commodity Standards Division, Office of Technical Services; transferred to the National Bureau of Standards July 1, 1963) and approved by the acceptors hereinafter listed, this Commercial Standard is issued by the U.S. Department of Commerce, effective April 1, 1965.

JOHN T. CONNOR, *Secretary.*

COMMERCIAL STANDARDS

Commercial Standards are developed by manufacturers, distributors, and users in cooperation with the Office of Commodity Standards of the National Bureau of Standards. Their purpose is to establish quality criteria, standard methods of test, rating, certification, and labeling of manufactured commodities, and to provide uniform bases for fair competition.

The adoption and use of a Commercial Standard is voluntary. However, when reference to a Commercial Standard is made in contracts, labels, invoices, or advertising literature, the provisions of the standard are enforceable through usual legal channels as a part of the sales contract.

Commercial Standards originate with the proponent industry. The sponsors may be manufacturers, distributors, or users of the specific product. One of these three elements of industry submits to the Office of Commodity Standards the necessary data to be used as the basis for developing a standard of practice. The Office by means of assembled conferences or letter referenda, or both, assists the sponsor group in arriving at a tentative standard of practice and thereafter refers it to the other elements of the same industry for approval or for constructive criticism that will be helpful in making any necessary adjustments. The regular procedure of the Office assures continuous servicing of each Commercial Standard through review and revision whenever, in the opinion of the industry, changing conditions warrant such action.

SIMPLIFIED PRACTICE RECOMMENDATIONS

Under a similar procedure the Office of Commodity Standards cooperates with industries in the establishment of Simplified Practice Recommendations. Their purpose is to eliminate avoidable waste through the establishment of standards of practice for sizes, dimensions, varieties, or other characteristics of specific products; to simplify packaging practices; and to establish simplified methods of performing specific tasks.

The initial printing of CS272-65 was made possible through the Plastics Pipe Institute, a Division of The Society of The Plastics Industry, Inc.

1765

Polyvinyl Chloride (PVC) Plastic Drain, Waste, and Vent Pipe and Fittings

(Effective April 1, 1965)

1. PURPOSE

1.1 The purpose of this Commercial Standard is to establish, on a national basis, standard dimensions and significant quality requirements for polyvinyl chloride (PVC) plastic drain, waste, and vent (DWV) pipe and fittings. It is also intended to inform producers, distributors, engineers, code officials, and users of the significant qualities of this product, to assist buyers and vendors in obtaining and vending quality merchandise for the benefit of the user, and to promote understanding among all these groups concerning commercially available PVC plastic DWV pipe and fittings.

2. SCOPE

2.1 This Commercial Standard covers requirements and methods of test for materials, dimensions, and tolerances, deflection load, crush resistance, hydrostatic burst resistance, chemical resistance, water resistance, flattening resistance, impact resistance, joint tightness, and solvent cement. A form of marking to indicate compliance with this standard is also included. Installation procedures are given in Appendix I and the recommended safety precautions for using the cement are given in Appendix II.

3. TERMINOLOGY

3.1 The plastics terminology used in this Commercial Standard is in accordance with definitions given in Tentative Definitions of Terms Relating to Plastics (ASTM Designation: D883-62T), unless otherwise indicated.¹

3.2 The plumbing terminology used in this Commercial Standard is in accordance with the definitions given in National Plumbing Code, Minimum Requirements for Plumbing (ASA A40.8-1955), unless otherwise indicated.²

4. USES

4.1 The requirements of this standard are intended to provide pipe and fittings suitable for drainage, waste, and vent piping systems in the drainage of sewage and other liquid wastes where toughness, resistance to deterioration from water and chemicals, flattening and aging resistance, and strong tight joints are required.

¹ Copies of ASTM publications are obtainable from The American Society For Testing and Materials, 1916 Race St., Philadelphia, Pa., 19103.

² Copies of ASA publications are obtainable from the American Standards Association, 10 East 40th St., New York, N.Y., 10016.

5. MATERIAL REQUIREMENTS

5.1 **Basic materials.**—Pipe and fittings shall be made from virgin Type I Grade 1, Type I Grade 2 or Type I Grade 3, or Type II Grade I polyvinyl chloride compounds, as defined and described in Tentative Specification for Rigid Polyvinyl Chloride Compounds (PVC) (ASTM Designation: D1784-60T). This plastic may contain stabilizers, lubricants, and pigments. Test specimens shall be molded under conditions specified by the manufacturer from the extrusion compound, or be cut from sections of finished pipe. In all cases of disagreement, test specimens molded under conditions specified by the manufacturer shall be used.

5.2 **Rework material.**—Clean, rework material, generated from the manufacturer's own pipe or fitting production, may be used by the same manufacturer, provided that the pipe or fittings produced meet all the requirements of this standard.

6. PHYSICAL AND CHEMICAL REQUIREMENTS

6.1 **General.**—The pipe and fittings shall be homogeneous throughout and free from visible cracks, holes, foreign inclusions, or other injurious defects. The pipe shall be as uniform as commercially practicable in color, opacity, density, and other physical properties.

6.2 Dimensions and Tolerances.

6.2.1 Pipe.

6.2.1.1 **Pipe diameters.**—The outside diameter of the pipe shall meet the requirements given in table 1 when measured in accordance with paragraph 8.4.

6.2.1.2 **Pipe wall thickness.**—The wall thicknesses of the pipe shall meet the requirements given in table 1 when measured in accordance with paragraph 8.4.

TABLE 1.—Dimensions and tolerances for PVC plastic drain, waste, and vent pipe

Nominal pipe size	Outside diameter			Minimum wall thickness
	Average	Tolerance on average	Permissible deviations of diameter from measured average (out-of-roundness)	
<i>Inch</i> 1¼	<i>Inch</i> 1.680	<i>Inch</i> ±0.005	<i>Inch</i> ±.012	<i>Inch</i> 0.140
1½	1.900	±0.006	±.012	0.145
2	2.375	±0.006	±.012	0.154
3	3.500	±0.008	±.015	0.216
4	4.500	±0.009	±.015	0.237

6.2.1.3 **Pipe length.**—The pipe shall be in either 10-foot or 20-foot lengths, unless otherwise specified, when measured in accordance with paragraph 8.4, with allowable tolerances of +½ inch, minus 0 inch.

6.2.2 Fittings.

6.2.2.1 **Fitting socket dimensions.**—The socket dimensions of fittings shall meet the requirements given in table 2 when measured in accordance with paragraph 8.4.

TABLE 2.—Dimensions and tolerances for fitting sockets for PVC plastic drain, waste, and vent pipe fittings (inches)

Size	Socket entrance diam.		Socket bottom diam.		Socket depth	Wall thickness	Internal thread length
	Average ¹	T _m ²	Average ³	T _m ²	Min.	Min. ⁴	Min.
1¼	1.675	±.012	1.655	±0.012	1¼	⅝	1¼
1½	1.915	±.012	1.895	±.012	1¼	⅝	1¼
2	2.390	±.012	2.370	±.012	¾	⅝	¾
3	3.520	±.015	3.495	±.015	1½	⅞	1¾
4	4.520	±.015	4.495	±.015	1¾	⅞	1¾

¹ Average is the maximum plus the minimum diameters divided by 2. The tolerance on this average is +0.010 to -0.005 inch.

² T_m = Permissible deviation of diameter from measured average, often called out-of-roundness.

³ Tolerance on average ±0.005 inch for 1¼ through 2 inch sizes; +0.005 -0.010 inch for 3 and 4 inch sizes.

⁴ This minimum wall thickness requirement applies throughout the fitting.

6.2.2.2 **Fitting laying length dimensions.**—The laying length dimensions of fittings shall conform to the requirements given in tables 3 and 4.³

6.2.2.3 **Transition adapters.**—The dimensions of adapters for connecting plastic pipe to cast iron and clay pipe hubs and spigots shall conform to the dimensions given in table 5.

6.3 **Deflection load and crush resistance.**

6.3.1 **Pipe.**—The pipe shall support a minimum load of 1500 pounds per linear foot at 15 percent deflection of the original diameter (deflection load) and shall deflect 60 percent of the original diameter (crush resistance) without cracking, rupture, or other visible evidence of failure when tested in accordance with section 8.5. (This test is intended only for use as a quality control test, not for use as a simulated service test.)

6.3.2 **Fittings.**—Individual fittings unassembled shall withstand a minimum load of 750 pounds per foot of length without cracking or other visible evidence of failure when tested in accordance with section 8.5. (This test is intended only for use as a quality control test, not for use as a simulated service test.)

6.4 **Minimum hydrostatic burst pressure.**—When tested at 23 °C (73.4 °F) in accordance with paragraph 8.6, the minimum burst pressure of pipe shall be in accordance with table 6 and the minimum burst pressure of fittings shall be 200 psi.⁴

6.5 **Chemical resistance.**—The pipe and fittings shall not increase in weight more than 0.50 percent and shall not change in deflection load and crush resistance more than ±15 percent when tested in accordance with paragraph 8.7.

³ Fittings other than standard fittings shown in tables 3 and 4 are available. Laying lengths for these fittings are determined by the individual manufacturers.

⁴ The minimum burst pressures for fittings are lower than that for pipe because the geometry is such, particularly area and radii, that the stresses produced in the walls of the fittings are higher than those produced in pipe tested at the same internal pressures. (This requirement is intended only for the purpose of quality control to insure that the pipe and fittings have no weak areas, particularly at flow and weld lines. It is not intended for use as a simulated service test.)

TABLE 3. LAYING LENGTH DIMENSIONS FOR PVC PLASTIC DRAINAGE PIPE FITTINGS¹

Size	G	J	GN Min.	JJ	JN	Laying Length, Tolerance, Center Line to Socket Bottom
1-1/4	1-9/16	1-1/16	11/16	2-9/16	1-1/16	±5/32
1-1/2	1-25/32	1-5/32	15/16	2-29/32	1-5/32	±3/16
2	2-5/16	1-1/2	1-5/16	3-5/8	1-3/8	±3/16
3	3-1/16	1-3/4	1-11/16	5-5/32	1-9/16	±1/4
4	3-7/8	2-7/32	2-3/16	6-13/32	1-29/32	±1/4

¹ All dimensions are in inches. The pitch of the socket for parts with 90° angles shall be 1/4 inch per foot or 1 degree 12 minutes.

TABLE 4. LAYING LENGTH DIMENSIONS FOR PLASTIC VENT FITTINGS¹

Size	G Min.	GN Min.	GJ Min.
1-1/4	7/8	---	---
1-1/2	1	---	---
2	1-1/4	---	---
3	1-13/16	---	---
3 X 3 X 1-1/2	---	1	1-13/16
3 X 3 X 2	---	1-1/4	1-13/16

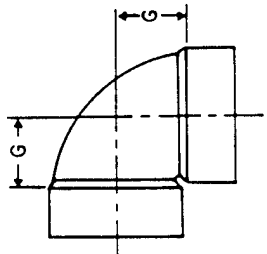

1/4 BEND VENT

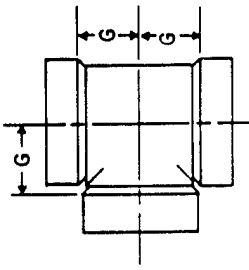

TEE VENT

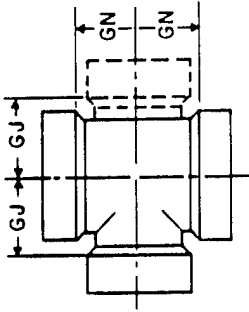

TEE VENT
REDUCING
SINGLE & DOUBLE

¹All dimensions are in inches.

TABLE 5. TRANSITION ADAPTERS

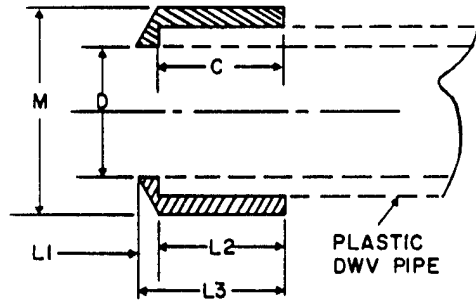

PLASTIC ADAPTER
Cemented over end of plastic pipe to adapt it for connection to cast iron hub.

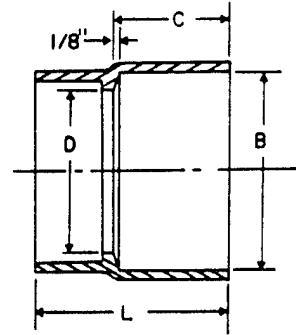

PLASTIC HUB
Adapts cast iron spigot to plastic pipe.

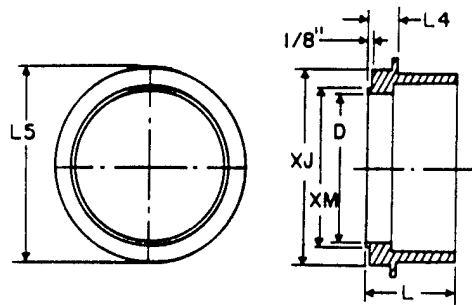

PLASTIC ADAPTER
Cements over end of plastic pipe to adapt it for connection to clay pipe hub.

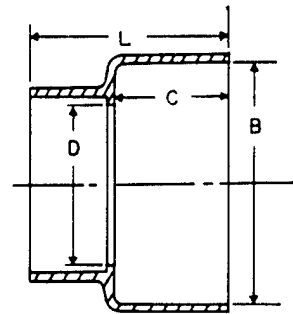

PLASTIC HUB
Adapts clay pipe spigot to plastic pipe.

TABLE 5. Transition Adapters (Cont.)¹

PLASTIC ADAPTER FOR CAST IRON										PLASTIC HUB FOR CAST IRON				
Size	C Min.	D Min.	M Min.	L1 Min.	L2 Min.	L3 Min.	Size	L Min.	B Min.	C Min.	D Min.			
2	13/16	2-1/16	2-5/8	1/8	7/8	1	2	3-1/2	2-15/16	2-1/2	2-1/16			
3	13/16	3-1/16	3-3/4	1/8	7/8	1	3	4-3/8	3-15/16	2-3/4	3-1/16			
4	13/16	4-1/32	4-3/4	1/8	7/8	1	4	4-7/8	4-15/16	3	4-1/32			
PLASTIC ADAPTER FOR CLAY PIPE										PLASTIC HUB FOR CLAY PIPE				
Size	L Min.	D Min.	XM Min.	HJ Min.	L4 Min.	L5 Min.	Size	L Min.	B Min.	C Min.	D Min.			
4	2-7/16	4	4-1/4	5-1/4	13/16	5-7/8	4	5	6-1/8	3	4-1/32			

¹All dimensions are in inches.

TABLE 6.—Minimum hydrostatic burst pressure at
23 °C (73.4 °F)

Size inch	Burst pressure, minimum *	
	Type I psi	Type II psi
1¼	1180	920
1½	1060	830
2	890	690
3	840	660
4	710	560

* These burst pressures are calculated in accordance with Tentative Recommended Practice for Calculating Stress in Plastic Pipe under Internal Pressure (ASTM Designation: D2153-63T) using a hoop stress of 6400 psi for Type I and 5000 psi for Type II. This practice is based on the "ISO equation."

6.6 Water resistance.

6.6.1 **Water absorption.**—The pipe and fittings shall not increase in weight more than 0.50 percent when tested in accordance with paragraph 8.8.1.

6.6.2 **Wet deflection load and crush resistance.**—The minimum deflection load and crush resistance of wet specimens of pipe and fittings shall be within ± 5 percent of the actual average deflection load and average crush resistance of dry specimens when tested in accordance with paragraph 8.8.2.

6.7. **Flattening resistance.**—The average decrease in inside diameter of pipe and fittings shall not exceed 10 percent when tested in accordance with paragraph 8.9.

6.8 **Impact resistance.**—The minimum impact resistance of pipe and fittings shall be in accordance with table 7 when tested in accordance with section 8.10. (This test is intended only for use as a quality control test, not for use as a simulated service test.)

6.9 **Joint tightness.**—Joints made with pipe and fittings shall not leak when tested with an internal pressure of 25 psi in accordance with paragraph 8.11. (This test is intended only for use in determining the ability of the cement to produce tight joints between the pipe and the fittings, not for use as a simulated service test.)

7. SOLVENT CEMENT REQUIREMENTS

7.1 **General.**—Solvent cements for use with this pipe and these fittings shall be those recommended by manufacturers for use on PVC plastic pipe and fittings and shall meet the following requirements.⁵

CAUTION: If longer opening time is required for some particular types of installation, special instructions and specifications should be requested from the cement manufacturer. Any solvent cement of this "longer-open-time" type should be evaluated for possible deleterious effects on the pipe and fittings. The use of slower drying solvent cement should be avoided if at all possible.

7.1.1 **Composition.**—The solvent cement shall be manufactured by dissolving solute in solvent. Fillers to increase viscosity and/or reduce shrinkage may be added. The solvent cement shall contain 5 to 20 percent by weight of solute as determined in accordance with paragraph 8.12.1. The controlling factor of the exact amount of

⁵ The solvent cement will provide sufficient open time for making good joints and connections but joints shall be completed immediately upon applying solvent cement. Should any delay develop in assembly, an additional coat of solvent cement should be applied immediately prior to joining.

solute added shall be the viscosity of the solvent cement. The viscosity (Brookfield) of the cement shall be a minimum of 800 centipoises at 25° C (77° F) when determined in accordance with paragraph 8.12.2. The solvent cement shall be free-flowing and shall not contain lumps, gel particles, undissolved resin, or foreign material, and shall have the ability to dissolve an additional minimum of 5 percent by weight of the pipe or fitting material at room temperature, 20 to 30 °C (68 to 85 °F), in 8 hours.

7.1.1.1 **Solute.**—The solute shall be Type I Grade 1 or Type 1 Grade 2 PVC plastic materials.

7.1.1.2 **Solvent.**—The solvent used shall be a mixture of tetrahydrofuran and cyclohexanone or dimethylformamide, with the tetrahydrofuran the major component by volume. Only the solvent specified in this paragraph shall be used for adjusting the viscosity of the cement, when necessary.

7.1.2 **Packaging and labeling.**—The solvent cement shall be packaged in one-quart containers or smaller for field use. The label on the containers for solvent cement shall bear the name of the manufacturer, the type of cement, recommended procedure for use, and safety procedures, normally required for solutions containing solvent of this type.

7.1.3 **Safety requirements.**—(See Appendix II.)

8. METHODS OF TEST

8.1 **Sampling.**—A sample of the pipe and fittings sufficient to determine conformance with this standard shall be taken at random from each lot or shipment. About 40 feet of pipe are required to make the tests prescribed. The number of fittings required varies depending on the size and type of fitting.

8.2 **Conditioning test specimens.**—Unless otherwise specified, the specimens shall be conditioned prior to test at 23 ± 2 °C (73.4 ± 3.6 °F) and 50 ± 5 percent relative humidity for not less than 48 hours in accordance with Procedure A in Standard Method of Conditioning Plastics and Electrical Insulating Materials for Testing (ASTM Designation: D618-61) for those tests where conditioning is required and in all cases of disagreement.

8.3 **Test conditions.**—Tests shall be conducted in a laboratory atmosphere of 23 ± 2 °C (73.4 ± 3.6 °F) and 50 ± 5 percent relative humidity, unless otherwise specified.

8.4 **Dimensions and tolerances.**—Dimensions shall be measured on five cleanly cut specimens of pipe and on five fittings with micrometers accurate to 0.001 inch. Measurements shall be made in accordance with method of Determining Dimensions of Thermoplastic Pipe (ASTM Designation: D2122-62T). Measured values shall be examined for conformance to the requirements of paragraphs 6.2.1 and 6.2.2.

8.4.1 **Outside diameter.**—Sufficient measurements shall be made in accordance with Section 7 of D2122-62T, minimum of four, around the pipe or fitting to ascertain that the maximum and minimum outside diameters have been determined. The average outside diameter is the arithmetic average of the maximum and minimum diameters at any cross section. All individually measured outside diameter values shall be examined for conformance with the tolerances specified in tables 1 and 2.

8.4.2 **Wall thickness.**—Sufficient wall thickness measurements shall be made in accordance with Section 4 of D2122-62T, a minimum of four, around the pipe or fitting to ascertain that the minimum wall thickness has been determined. The wall thicknesses shall be measured at both ends of the specimens.

8.4.3 **Length.**—Pipe length and other linear dimensions shall be measured with a steel tape accurate to $\pm 1/32$ inch in 10 feet.

8.5 **Deflection load and crush resistance.**—The deflection load and crush resistance of pipe and fittings shall be measured by the following method:

8.5.1 **Principle.**—A short length of pipe or a fitting is loaded between two rigid parallel flat plates at a controlled rate of approach to one another. In the test for pipe the load when the initial diameter is reduced 15 percent shall be noted (deflection load). The test shall be continued until the diameter is deflected to 60 percent of its original value (crush resistance).

8.5.2 **Apparatus.**—The apparatus shall consist of the following:

(a) **Testing machine.**—A properly calibrated compression testing machine of the constant-rate-of-crosshead-movement type meeting the requirements of Section 4(a) in ASTM D695-63T shall be used to make the tests. The rate of head approach shall be 0.20 to 0.25 inch per minute.

(b) **Loading plates.**—The load shall be applied to the specimen through two parallel steel bearing plates. The plates shall be flat, smooth (free from machining marks) and clean. The thickness of each plate shall be not less than 0.25 inch and the length not less than 6.5 inches. The width of each plate shall be not less than 1.5 times the outside diameter of the pipe specimen.

(c) **Deformation (deflection) indicator.**—The change in inside diameter or deformation (deflection) parallel to the direction of loading shall be measured with a suitable instrument meeting the requirements of Section 4(d) in ASTM D695-63T except that the instrument shall be accurate to the nearest 0.001 inch. The instrument shall not support the pipe test specimen or affect in any way the load-deflection measurements. Alternatively, changes in outside diameter may be measured during loading by continuously recording plate travel in place of inside diameter measurements.

8.5.3 **Pipe test specimens.**—Three specimens, each $6 \pm 1/8$ inches long, shall be tested for conformance with the requirements of paragraph 6.3.1. The ends shall be cut square and free of burrs and jagged edges.

8.5.4 **Fitting test specimens.**—Three complete fittings shall be tested for conformance with the requirements of paragraph 6.3.2. Fittings having non-uniform diameters such as reducers, shall be considered acceptable when the wall thickness at any point is equal to or greater than the wall thickness of pipe of the same material and diameter that meets the crush resistance requirements.

8.5.5 **Procedure.**—

(a) Starting at the thinnest wall location, measure the wall thickness to the nearest 0.001 inch at 45° intervals. At these same locations, measure the inside diameters to the nearest 0.01 inch. The pipe length shall be measured to the nearest 0.01 inch. These measurements shall be made on each test specimen after conditioning.

(b) Locate pipe specimen with its axis parallel to the bearing plates and center it laterally in the testing machine. The line marking the thinnest wall of the specimen shall be either at the top or bottom bearing plate.

(c) Measure the vertical inside or outside diameter near the center with specimen in test position but not in contact with the upper plate.

(d) With the deflection indicator in place, bring upper plate down to contact specimen with no more load than necessary to hold it in place. Record any deflection.

(e) Specimen shall be compressed at a constant (vertical) deflection rate of 0.20 to 0.25 inch per minute.

(f) Terminate the test when the diameter of pipe test specimens is reduced to 40 percent of its original value or the pipe cracks or shows other evidence of visible failure. Terminate the test on fittings when the load reaches 750 pounds per foot of length.

(g) Observe the load and deflection at the first evidence of cracking, if any. Record location and type of failure.

8.5.6 Calculations.—For pipe divide the load in pounds at 15 percent deflection (deflection load) and also at failure (crush resistance), if such occurred, by the length of the pipe test specimen in feet, to obtain the deflection load and crush resistance respectively in pounds per linear foot. Calculate the values for each specimen separately. The test results for each specimen of pipe and fittings shall be examined for conformance to the requirements in paragraphs 6.3.1 and 6.3.2.

8.6 Minimum hydrostatic burst pressure.—The test equipment and procedure shall be as specified in Tentative Method of Test for Short Time Rupture Strength of Thermoplastic Pipe Tubing and Fittings (ASTM Designation: D1599-62T). The test specimens shall be selected at random. Three specimens of pipe, each ten times the nominal diameter or a maximum of three feet in length, shall be tested. Three complete fittings shall be tested. The specimens shall be tested individually with water under pressure that is increased at an even rate to burst the specimen within a period of 60 to 90 seconds. One end of the pipe or fitting shall be rigidly fitted to the pressurizing apparatus and the other end shall be free but supported at the free end if necessary. Care shall be taken to remove all air from the pipe before capping and testing. Any suitable closure that is free of leaks at maximum pressure may be used. The specimens shall be conditioned at 23 °C (73.4 °F), for at least 2 hours before testing. The water temperature shall be within plus or minus 1.7 °C (3.0 °F) of the conditioning temperature and the test results for each specimen shall be examined for conformance to the requirements of paragraph 6.4.

8.7 Chemical resistance.—The resistance to the following chemicals shall be determined in accordance with Tentative Method of Test for Resistance of Plastics to Chemical Reagents (ASTM Designation: D543-60T):

<i>Chemicals</i>	<i>Concentration in water solution</i>	<i>Chemicals</i>	<i>Concentration in water solution</i>
Sodium carbonate.....	0.1 N	Acetic acid.....	5 percent
Sodium acid sulfate.....	0.1 N	Sodium hydroxide.....	0.2 N
Sodium sulfate.....	0.1 N	Ivory soap.....	5 percent
Sulfur chloride.....	5 percent	Household detergent.....	5 percent
Sulfuric acid.....	0.1 N	Raw sewage.....	---
Hydrochloric acid.....	0.2 N		

The test specimens for pipe shall be six inches long and cleanly cut. The fittings specimens shall consist of complete fittings. Three specimens shall be tested with each reagent. The specimen shall be weighed to the nearest 0.1 gram and completely immersed in the chemicals for 72 hours. On removal from the chemicals, the specimens shall be washed with running water, wiped with a clean dry cloth, conditioned for a period between 120 and 135 minutes, and reweighed. The increase in weight shall be calculated to the nearest 0.01 percent on the basis of the initial weight. The specimen shall then be tested to determine the deflection load and crush resistance in accordance with section 8.5, within 30 minutes after weighing. Weight and deflection-crush test for each specimen shall be examined for conformance to the requirement of paragraph 6.5.

8.8 Water resistance.

8.8.1 **Water absorption.**—Three cleanly cut test specimens of pipe at least 6 inches long or three complete fittings shall be weighed to the nearest 0.1 gram and immersed in water at 23 ± 2 °C (73.4 ± 3.6 °F) for 48 hours. The specimens shall be removed, wiped dry with a clean dry cloth, and reweighed immediately. The average percent gain in weight shall be calculated to the nearest 0.01 percent on the basis of the initial weight, and shall be used to determine compliance with paragraph 6.6.1.

8.8.2 **Wet deflection load and crush resistance.**—The specimens used to make the water absorption tests shall be tested for deflection load and crush resistance in accordance with section 8.5 within 30 minutes after removal from the water. Test results for deflection load and crush resistance of each specimen shall be examined for conformance with the requirements of paragraph 6.6.2. For the calculation of percent change in deflection load and crush resistance, the average values for dry specimens shall be obtained by averaging the results obtained to determine compliance with section 6.3.

8.9 **Flattening resistance.**—Four test specimens each 6 inches in length shall be cleanly cut from the pipe. The fitting specimens shall consist of four complete fittings. A diameter shall be marked and measured on the inside to the nearest 0.001 inch. The specimens shall be placed on a flat rigid base with the measured diameter in a vertical position and the assembly placed in a circulating-air oven. Pairs of test specimens shall be loaded symmetrically by means of a rigid plate with a total load of 55 pounds. The heat shall then be turned on in the oven and the temperature raised to 50 ± 3 °C (122 ± 5.4 °F) and held there for 40 ± 1 hours. The specimens shall be unloaded and removed from the oven. After cooling for 1 hour, the marked and measured inside diameters shall be remeasured and the average change in percent of the initial diameter shall be calculated. The results shall be examined for conformance to the requirements of paragraph 6.7.

8.10 **Impact resistance.**—The impact resistance of pipe and fittings shall be measured by the following method:

8.10.1 **Principle.**—The pipe or fitting test specimen is struck by a 12-pound tup with a 1/2-inch radius nose, dropped from the proper height to produce the required impact energy.

8.10.2 **Apparatus.**—The apparatus shall consist of the following:

8.10.2.1 **Tup.**—A steel cylinder 2.500 ± 0.002 inches in diameter

weighing 12 pounds with a taper on one end, and flat or with a rod extending on the other end, as shown in figures 1 and 2.

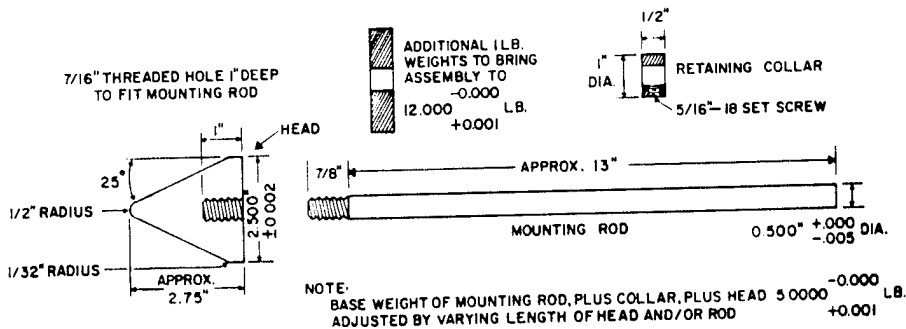

TO BE MADE OF COLD ROLLED STEEL, FINISH ALL OVER TO BE 32 MICROINCH

ALTERNATELY, THE TUP CAN BE MADE IN ONE PIECE, AS SHOWN BELOW

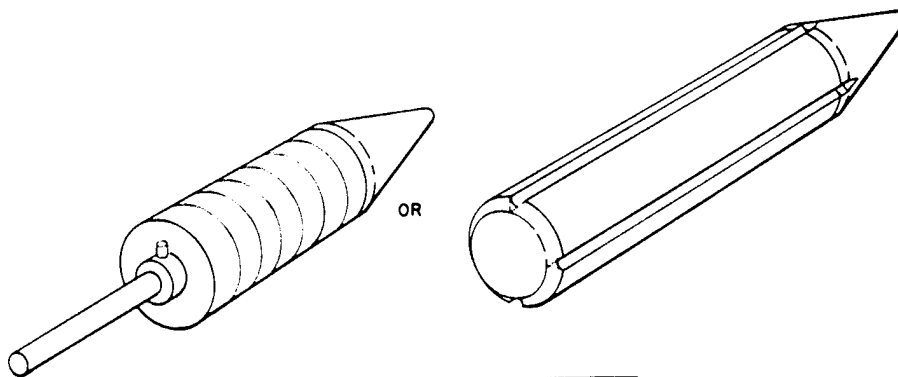
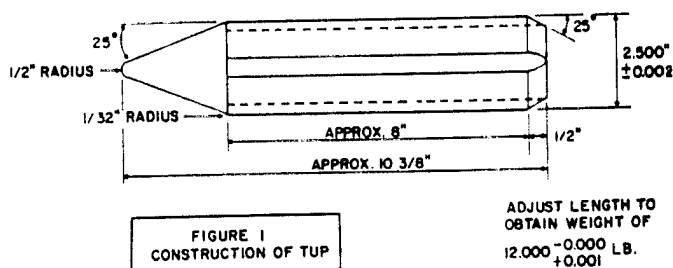
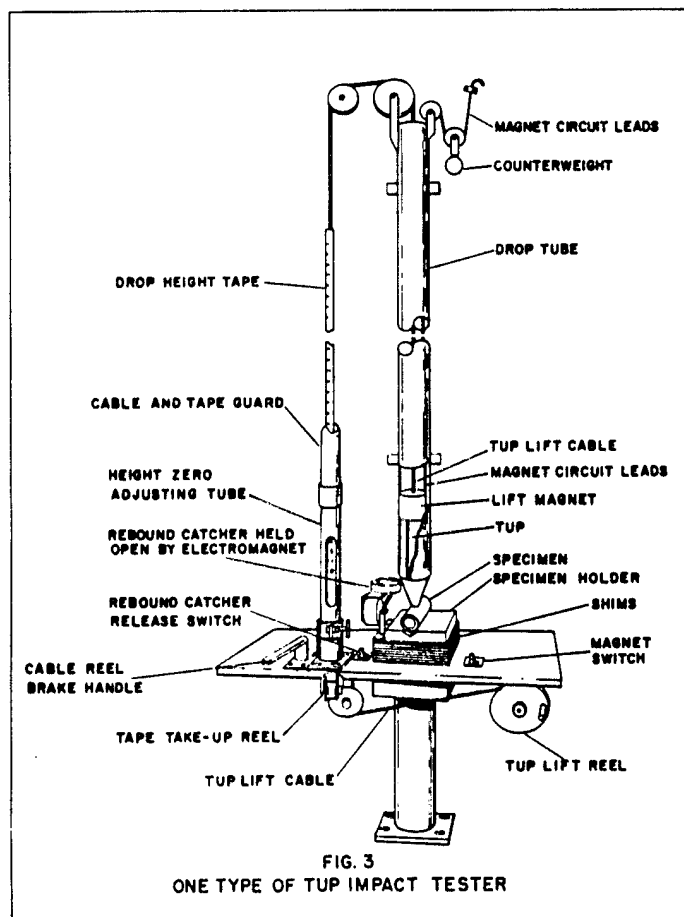

FIGURE 2 PERSPECTIVE VIEW OF TUP

8.10.2.2 Drop tube.—The drop tube shall be made of cold-drawn seamless steel tubing with an inside diameter of 2.563 ± 0.003 inches, or of acrylonitrile-butadiene-styrene (ABS) or polyvinyl chloride (PVC) plastic pipe, 2½-inch nominal pipe size with a standard dimension ratio (SDR) of 21. Alternately, the tup may be dropped without a protective tube provided other means are provided to protect the operator from the random rebound of the tup. The drop tube shall be sufficiently long (at least 10 feet) to provide for a height of fall of at least 9 feet and shall be mounted so that the lengthwise dimension is vertical as determined by a plumb bob.

8.10.2.3 Tup hold and release.—Means shall be provided to hold the tup at steps of 1-inch up to 5-feet above the pipe or fitting test specimen, as measured from the bottom of the tup to the top of the specimen as mounted; to release the tup in a reproducible manner; to allow the

tup to fall freely through the tube to strike the specimen; and to catch the tup on the first rebound. One suitable device is shown in figure 3.



8.10.2.4 **Specimen holder.**—The pipe specimen holder shall consist of a steel plate, 8 by 12 by 1 inch in which a V-groove to position the pipe specimen shall be cut. This V-groove shall be $\frac{1}{8}$ -inch deep with an included angle of 120 degrees. The edges of the V-groove shall be rounded to $\frac{1}{16}$ inch. Fittings shall be laid on their side on a 1-inch thick steel plate. Fittings that do not contact the steel plate directly under the point of impact shall be supported in this area by a steel shim or small steel plate. The specimen holders shall be mounted on a firm rigid base fastened to a heavy concrete slab. Means shall be provided to adjust the specimen holders so that the specimens can be centered under the end of the drop tube. A bar or rod placed inside the pipe specimen and held there by a light spring may be used to fix the specimen if difficulty is encountered in holding the specimen in place.

8.10.3 Test specimens.

8.10.3.1—At least six pipe specimens shall be tested. Specimen length shall be $6 \pm \frac{1}{8}$ inches, after burrs on ends have been removed.

8.10.3.2—Six fittings shall be tested unassembled, except for couplings. Pieces of pipe shall be cemented into couplings so that each piece of pipe extends 6 ± 0.5 inches and the assembly allowed to stand in open air for 24 hours, after which period the cemented assembly shall be tested.

8.10.4 Procedure.

8.10.4.1—The dimensions of the pipe test specimens shall be measured in accordance with Tentative Method of Determining Dimensions of Thermoplastic Pipe (ASTM Designation: D2122-62T). The position of the thinnest wall of each pipe specimen shall be noted.

8.10.4.2—The thinnest wall of each fitting shall be determined.

8.10.4.3—The first pipe test specimen shall be mounted with the thinnest wall section on top so that the tup strikes this area. The second specimen shall be mounted so that the point of impact is 18 degrees from the thinnest wall, the third 36 degrees, etc.

8.10.4.4—(1) Symmetrical fittings shall be struck on the weld mark and 90 degrees from the weld mark; three specimens shall be impacted on the weld and three specimens 90 degrees from the weld. If the weld mark cannot be located, then the thinnest wall shall be used in place of the weld.

(2) Unsymmetrical fittings shall be tested by laying the specimen on its side and impacting the other side at the geometrical center. Three specimens shall be struck on one side and three on the other.

8.10.4.5—The test specimen shall be placed under the end of the drop tube so that the side of the pipe or fitting shall be struck by the tup on the geometrical center of the side. The 12-pound tup shall be dropped from the height necessary to provide the impact energy requirement given in table 7. Each test specimen shall be subjected to only one impact blow.

8.10.4.6—The impacted specimens shall be carefully examined visually inside and outside to observe cracking or any other evidence of failure.

8.10.4.7—Failure in the test specimens shall be any crack or split on the inside or outside that was created by the impact and that can be seen by the naked eye. Lighting devices shall be used to assist in examining for cracks and splits in the walls of the pipe or fittings specimens. Cracks not in the wall of the fitting, that is in places that would not be expected to affect the strength of the fitting such as cracks in the stop of a coupling parallel to the wall of the coupling shall not be considered as failure.

8.10.4.8—Failure of two or more of the specimens shall be deemed as failure of the product to meet the specified impact resistance requirement as given in paragraph 6.8 and table 7. When only one specimen fails, a retest utilizing six additional specimens shall be made. To meet the specified impact resistance requirement, none of the six additional specimens shall fail in the retest.

TABLE 7.—Impact resistance of PVC plastic DWV pipe and fittings

Nominal pipe size	Impact resistance minimum, at 73 °F
<i>Inch</i>	<i>ft-lb</i>
1¼.....	52
1½.....	56
2.....	59
3.....	75
4.....	102
Fittings	
Type I all sizes.....	10
Type II all sizes.....	20

8.11 **Joint tightness.**—Two pieces of pipes shall be joined together with a fitting by solvent cement and allowed to stand for 24 hours at room temperature. The specimen shall then be subjected to an internal pressure of 25 psi, with water as the medium, for 24 hours. The pipe, fitting, and joints shall be examined for leakage to determine conformance to the requirement of paragraph 6.9.⁶

8.12 **Solvent Cement.**

8.12.1 **Solute.**—One hundred grams (± 10 grams) of the cement shall be weighed to the nearest 0.1 gram, diluted with solvent, and filtered into a previously weighed aluminum dish. The sample shall be evaporated to dryness in a steam bath and then dried in an oven at 104 ± 2 °C (219 ± 3.6 °F) to constant weight. The calculated value shall be used for determining compliance with the requirement of paragraph 7.1.1. Total solids shall be calculated as follows:

$$\text{Solute (\%)} = \frac{\text{Weight of dried residue}}{\text{Original wt. of sample}} \times 100$$

8.12.2 **Viscosity.**—The viscosity shall be determined at 25 ± 2 °C (77 ± 3.6 °F) with a Brookfield Viscosimeter in accordance with Method B of Consistency of Adhesives (ASTM Designation: D1084-60) using spindle No. 4 and a speed of 10 rpm. The value of the viscosity thus obtained shall be used for determining compliance with the requirement of paragraph 7.1.1.

9. MARKING AND LABELING

9.1 Marking.

9.1.1 **Pipe.**—The pipe shall be marked on two sides 180 degrees apart or spirally in letters not less than $\frac{1}{16}$ -inch high in a contrasting color and shall at least consist of the manufacturer's name or trademark, the nominal pipe size, the symbol PVC, the type designation (I or II), Schedule 40, CS272-65, and the symbol "DWV", spaced at intervals of not more than 2 feet.

9.1.2 **Fittings.**—All fittings shall be marked on the body or hub on both sides. The marking shall consist, at least, of the manufacturer's name and/or trademark, and the symbol PVC, and the type designation (I or II).

9.2 **Labeling.**—In order that purchasers may be assured that the PVC plastic drain, waste, and vent pipe and fittings actually comply with all requirements of this standard, it is recommended that the manufacturers include a statement in conjunction with their name and address on labels, invoices, sales literature, etc., to the effect that the specific pipe and/or fittings covered by the statement meet the requirements of this standard, referenced by number and title.

HISTORY OF PROJECT

On June 2, 1962, the Thermoplastics Pipe Division, now the Plastic Pipe Institute, a Division of The Society of the Plastics Industry, Inc. requested the cooperation of the Office of Commodity Standards in establishing a Commercial Standard for Polyvinyl Chloride (PVC) Plastic Drain, Waste and Vent Pipe and Fittings. After discussions between members of the Division and the PPI it was agreed that

⁶ For test conditions involving higher pressures in the field, joints should be allowed to stand for more extended periods.

certain editorial changes were necessary. The revised draft was submitted in October 1962.

The Office of Commodity Standards circulated copies of the proposed Commercial Standard to representative producers, distributors, users, laboratories, builders, architects, and Government agencies for comment on January 15, 1964. All comments and suggestions received were carefully considered and adjustments were made to the proposal to satisfy the comment wherever practicable. The Recommended Commercial Standard, TS-5608A, was widely circulated to industry on April 21, 1964, for consideration and acceptance. Sufficient acceptances were received from producers, distributors, and users to indicate success of the project. Over 90 percent of the domestic production capacity of the industry returned signed acceptance forms indicating approval of this Commercial Standard. Accordingly, on March 11, 1965, the new edition, Commercial Standard CS272-65, was announced to become effective for new production on April 1, 1965.

Project Manager: C. G. Hemmer, Office of Commodity Standards, National Bureau of Standards, U.S. Department of Commerce.

STANDING COMMITTEE

The following individuals comprise the membership of the Standing Committee, which is to review, prior to circulation for acceptance, revisions proposed to keep the standard abreast of progress. Comment concerning the standard and suggestions for revision may be addressed to any member of the committee or to the Office of Commodity Standards, National Bureau of Standards, which acts as Secretary for the committee.

Representing Producers:

Jerome C. Jehl, Carlon Products Corp., P.O. Box 133, Aurora, Ohio, 44202 (Chairman).

David W. Baird, Cabot Piping Systems, Plastics Division, Cabot Corp., P.O. Box 1032, Louisville, Ky., 40201.

M. B. Crawford, Can-Tex Industries, Inc., P.O. Box 340, Mineral Wells, Tex., 78067.

J. W. Hawley, Stauffer Chemical Co., Plastics Division, 3102 East 28th St., Los Angeles, Calif., 90023.

Robert W. Rosel, Celanese Plastics Co., Division of Celanese Corp. of America, Newark, N.J., 07102.

Representing Distributors:

Thomas A. Camp, Sears, Roebuck and Co., 925 S. Homan Ave., Chicago, Ill., 60607.

Lloyd L. Johnston, Jr., Marion Supply Co., P.O. Box 408, Marion, Ohio, 43304.

Edward F. Schofield, Aetna Engineering Co., Laurel St., Ashaway, R.I. 02804.

Representing Users:

Martin Roettger, UOP Chemical Co., Division of Universal Oil Products Co., East Rutherford, N.J., 07073.

Boyd A. Wright, Cannon & Mullen, Architects, 49 West South Temple, Salt Lake City, Utah, 84101.

Representing the Plastics Pipe Institute:

Frank W. Reinhart, Director, Technical Division, PPI, 9918 Sutherland Road, Silver Spring, Md., 20901.

APPENDIX I
**INSTALLATION PROCEDURES FOR PVC PLASTIC DRAIN, WASTE,
AND VENT PIPE**

1. **Visibility of marking.**—Always position pipe and fittings so that identifying markings are readily visible to inspection when installed.

2. **Jointing techniques.**

2.1 **Cutting of pipe.**—Cut pipe square without ragged or burred edges so that pipe ends seat squarely in the fitting socket. Insert pipe to the full depth of the socket.

2.2 **Preparation of socket joints.**—Clean all joining surfaces by wiping with a cloth dampened with methyl ethyl ketone so that they are free of dirt, grease and any foreign matter. Apply solvent cement with a natural bristle brush (see Appendix II for Safety Precautions). Apply a light thin coat of solvent cement first to the fitting socket. Next apply a heavy coating of solvent cement to the pipe for a length equal to the socket depth. Immediately force the pipe and fittings together with a slight twisting motion, if possible, to insure full engagement of pipe into the fitting socket. Remove excess solvent cement from the exterior of the joint with a clean dry cloth. Reasonable handling of the assembly is permissible within two minutes after joining. Do not attempt to disturb the pipe-fitting joint after the cement has set; damage to the joint and loss of fit may result. Should any delay develop in assembly, apply an additional coat of cement immediately prior to joining.

3. **Alinement.**—In assembling plastic pipe and fittings, exercise care to establish proper grade and alinement before joining with solvent cement. Installation may not be satisfactory if pipe and fittings are subject to strain by forced positioning to obtain grade or alinement. Do not bend the pipe.

4. **Threaded connections.**—Do not thread the plastic pipe. Use adaptor fittings when transition from pipe to threaded construction is necessary. All fittings having threads shall be threaded with American Standard Taper Pipe Thread (ASA B2.1). The plastic pipe-fitting joint in these fittings must be of the solvent cement type.

5. **Transition fittings.**

5.1 **Connections to traps.**—Use only approved type of traps and connect them by means of approved threaded trap adaptors. Solvent-cement the trap adaptors to the plastic pipe.

5.2 **Connection to closet flanges.**—Install screw type closet flanges in the drainage system by means of a threaded connection. Install calk type closet flanges in accordance with the procedures outlined in paragraph 8 of this Appendix.

5.3 **Connection to nonplastic pipe.**—When connecting plastic pipe to other types of piping use only approved types of fittings and adaptors designed for the specific transition intended.

5.4 **Thread tightness.**—Where a threaded joint is made, obtain tightness by maximum hand tightening plus additional tightening with a wrench not to exceed one full turn.

5.5 **Thread lubrication.**—Use only thread tape, petroleum jelly, or thread lubricant recommended by the manufacturer of the PVC plastic pipe and/or fittings.

6. **Supports.**

6.1 **Spacing.**—Support horizontal piping at intervals of not more than five (5) feet, at ends of branches, and at all points of change in direction. Support vertical piping in accordance with recommendations of the manufacturer. Support trap arms in excess of three (3) feet as close as possible to the trap.

6.2 **Approved hangers.**—Use metal or other approved hangers. Exercise care not to compress and distort the pipe.

6.3 **Building drains under floor slab.**—Make trench bottoms smooth and of uniform grade with either undisturbed soil or a layer of selected and compacted backfill so that no settlement will be encountered. Pipe must bear on this material throughout the entire length of its barrel.

7. **Exposure to elements.**—Normal construction site handling procedures can be followed. It is good practice to store pipe and fittings under suitable cover prior to installation.

8. **Transition to bell-and-spigot pipe.**—Make connections or transitions to bell-and-spigot cast-iron soil pipe and fittings and to bell-and-spigot pipe and fittings of other materials, with approved mechanical compression joints or calked joints made in an approved manner. In calking, pack the joint with oakum or hemp and fill with molten lead to a depth of not less than 1 inch. Allow a period of 4 minutes for cooling, following which calk the lead at the inside and outside edges of the joint.

APPENDIX II

SOLVENTS FOR USE WITH POLYVINYL CHLORIDE (PVC) PLASTIC DRAIN, WASTE, AND VENT PIPE AND FITTINGS

Safety precautions.—The following safety precautions are recommended when tetrahydrofuran, cyclohexanone, dimethylformamide, or methyl ethyl ketone are used.

1. **Ventilation.**

1.1 When pipe and fittings are being joined with solvent cement, or a solvent cleaner in partially enclosed working areas, a ventilation device should be used to clear these areas of all vapors.

2. **Flammability.**

2.1 In no case should any source of ignition be permitted in any part of the areas where the solvent or the solvent cement is being used.

3. **Containers.**

3.1 The solvent and methyl ethyl ketone cleaner should be dispensed only from approved safety containers.

3.2 The container for solvent cement should be tightly closed at all times except when the cement is being used.

3.3 All rags or other similar materials impregnated with the solvent or methyl ethyl ketone cleaner should be kept in a safety waste container. This container should be emptied of its contents on a daily basis.

4. Protection.

4.1 Proper eye protection in the form of chemical workers goggles or face shields is advisable when handling the liquid solvent.

4.2 Proper gloves that are impervious to and unaffected by the solvents or cleaner should be worn when contact with methyl ethyl ketone cleaner, solvent or solvent cement is likely. Particular care should be taken to avoid skin contact with these substances at all times.

5. Peroxide formation.

5.1 Only tetrahydrofuran which has been treated to prevent peroxide formation should be used as a solvent.

6. Technical background material.

6.1 Health hazards.

6.1.1 **Cyclohexanone.**—In certain instances, concentrations as low as 50 ppm can cause eye, nose, and throat irritation in humans. The consensus of various sources indicate that a degree of toxicity for cyclohexanone exists which warrants consideration whenever this substance is used.

6.1.2 **Dimethylformamide.**—Dimethylformamide may defat the skin or may be absorbed through the skin. There is experimental evidence of liver and kidney damage due to this substance. It is recommended that persons with any renal or liver disease or a history of any chronic skin disease should not be exposed.

6.1.3 **Methyl ethyl ketone.**—The vapor of methyl ethyl ketone is irritating to the eyes, nose, and throat. Fortunately, the odor and irritant properties of this substance limit the probability of voluntary exposure to high concentrations. However, it may cause irritation and drying of the skin.

6.1.4 **Tetrahydrofuran.**—Tetrahydrofuran is moderately hazardous for both acute and chronic exposures. It may cause irritation to mucous membranes at concentrations higher than the assigned Threshold Limit Values (200 ppm). High exposure causes narcosis and repeated excessive exposure may produce liver and kidney damage. On short-term exposure, 25,000 ppm will cause anesthesia.

6.2 Fire hazards.

6.2.1 **Cyclohexanone.**—Cyclohexanone is a moderate fire hazard when exposed to heat or flame and has a lower flammable limit of 1.1 percent of volume at 212 °F. The flash point is 147 °F.

6.2.2 **Dimethylformamide.**—The fire hazard is slight, although dimethylformamide is considered a flammable liquid. The flammable range at 212 °F is from approximately 2.2 to 15.2 percent by volume, and the flash point is 153 °F.

6.2.3 **Methyl ethyl ketone.**—Is a very flammable substance, having a flash point (open cup) of 22 °F. The flammable limits are from 1.8 to 11.5 percent by volume. The substance is also quite volatile.

6.2.4 **Tetrahydrofuran.**—Tetrahydrofuran is a highly flammable liquid having a flash point of 6 °F and a flammable range of from 2.0 to 11.8 percent by volume. The National Fire Protection Association considers all flammable liquids having a flash point of 20 °F or below as extremely flammable and dangerous. Further, in stored untreated tetrahydrofuran, peroxides are likely to form and be deposited on the sides of the container. These peroxides are explosive and may be detonated by jarring the container.

ACCEPTORS

The manufactures, distributors, users, and others listed below have individually indicated in writing their acceptance of this Commercial Standard prior to its publication. The acceptances indicate an intention to utilize the standard as far as practicable, but reserve the right to depart from it as may be deemed desirable. The list is published to show the extent of recorded public support for the standard, and should not be construed as indicating that all products made by the acceptors actually comply with its requirements.

ASSOCIATIONS (General Support)

American Institute of Supply Associations, Washington, D.C.	National Building Material Distributors Association, Chicago, Ill.
Carolina Lumber & Building Material Dealers Association, Charlotte, N.C.	Plastics Pipe Institute, A Div. of The Society of The Plastics Industry, Inc., New York, N.Y.
Central Supply Association, Chicago, Ill.	
Mobile Homes Manufacturers Association, Chicago, Ill.	

FIRMS AND OTHER INTERESTS

A.B.&I. Plastics Div. of The American Brass & Iron Foundry, Newark, Calif.	Colonial Plastics Manufacturing Co., The, Cleveland, Ohio
Aetna Engineering Co., Ashaway, R.I.	Columbia Gas System Service Corp., Columbus, Ohio
African Explosives and Chemical Industries Limited, Johannesburg, South Africa (General Support).	Consolidated Pipe Co. of America, Stow, Ohio
Allied Chemical Corp., Barrett Div., New York, N.Y.	Consolidated Supply Co., Portland, Oreg.
Allied Chemical Corp., Plastics Div., Morristown, N.J.	Cracker Asphalt Corp., Douglasville, Ga.
American Car & Foundry Div., ACF Industries, Inc., St. Charles, Mo.	Crane Supply Co., Chicago, Ill.
Anaconda American Brass Co., Waterbury, Conn.	Crescent Plastics, Inc., Evansville, Ind.
Anderson, Ted. D., Construction Co., Kokomo, Ind.	Cretex Companies, Inc., Minneapolis, Minn.
Arizona Plastic Extrusion Co., Phoenix, Ariz.	Crown-Line Plastics, Inc., Hamburg, Iowa
Ashton, Evans, Brazier & Associates, Architects, Salt Lake City, Utah	Day & Zimmermann, Inc., Engineers, Philadelphia, Pa.
Associated Builders, Inc., Anderson, Ind.	DeBell & Richardson, Inc., Hazardville, Conn.
Baldwin Extruded Products, Inc., Downey, Calif.	Diamond Alkali Co., Cleveland, Ohio
Barclay, Ayers & Bertsch, Grand Rapids, Mich.	Diversified Plastics, Inc., Memphis, Tenn.
Baystone Construction, Inc., Muncie, Ind.	Dolplex, Inc., Lake Park, Fla.
Bellows, W. S., Construction Corp., Houston, Tex.	Dow Chemical Co., The Midland, Mich.
Bergemann & Associates, Architects, Alliance, Ohio	Drilling Specialties Co., Bartlesville, Okla.
Bismarck, City of, Building Department, Bismarck, N. Dak.	Elk River Concrete Products, Minneapolis, Minn.
Borden Chemical Co., Resinite Div., No. Andover, Mass. (General Support).	Elk River Concrete Products Co. of Montana, Helena, Mont.
Brunswick Corp., Marlon, Va.	Ellerbe Architects, St. Paul, Minn.
Brust & Brust, Architects, Milwaukee, Wis.	Ellingford Bros., Inc., Evanston, Wyo.
Busada Manufacturing Corp., Flushing, N.Y.	Engineered Plastic Products Co., Spokane, Wash.
Busser Supply Co., Lewisburg, Pa.	Esco Corp., Los Angeles, Calif.
Cabot Piping Systems, Plastics Div., Cabot Corp., Louisville, Ky.	Ethyl Corp., Ethyl Plastics Div., Baton Rouge, La.
California Chemical Co., Union, N.J.	Evanite Plastic Co., Div. of Evans Pipe Co., Carrollton, Ohio
Can-Tex Industries, Inc., Cannelton, Ind.	Farm & Wholesale Supply Co., Schneckeville, Lehigh County, Pa.
Can-Tex Industries, Inc., Southwestern Plastic Pipe Div., Mineral Wells, Tex.	Federal Corp., Oklahoma City, Okla.
Can-Tex Industries, Inc., Southwestern Plastic Pipe Div., Phoenix, Ariz.	Ferguson, H. K. Co., The, Plastic Application Div., Cleveland, Ohio
Cannon & Mullen, Architects, Salt Lake City, Utah	Findlay Supply Co., The, Findlay, Ohio
Carlson Products Corp., Aurora, Ohio	Flannagan, Eric G., & Sons, Architects-Engineers, Henderson, N.C.
Cary Chemicals Inc., East Brunswick, N.J.	Florida State Board of Health, Bureau of Sanitary Engineering, Jacksonville, Fla.
Celanese Plastic Co., A Div. of Celanese Corp. of America, Newark, N.J.	Garden State Wholesale Building Materials Co., Camden, N.J.
Cla de Productos de Arcilla, S. A., Panama, R. de P.	Gaspro Ltd., Honolulu, Hawaii
	Gering Plastics Co., A Dept. of Monsanto Co., Kenilworth, N.J.
	Glamorgan Pipe & Foundry Co., Plastics Div., Lynchburg, Va.
	Goodall Rubber Co., Trenton, N.J.

Goodrich, B. F., Chemical Co., Cleveland, Ohio
 Goodyear Tire & Rubber Co., The, Plastics Dept., Akron, Ohio
 Grellinger-Rose Associates, Inc., Milwaukee, Wis. (General Support)
 Grinnell Co., Inc., Providence, R.I.
 Grover Electric & Plumbing Supply Co., Vancouver, Wash.
 Gulf Research & Development Co., Materials & Equipment Div., Pittsburgh, Pa.

Halby Chemical Co., Inc., Wilmington, Del.
 Hardware & Supply Co., The, Akron, Ohio
 Harvel Plastics, Inc., Easton, Pa.
 Hilton & Carr Construction Co., Ogden, Utah
 Hogner, P. R. L., Architect, Fort Lauderdale, Fla.
 Holmes & Hudson Co., Sioux City, Iowa
 Hope, Frank L., & Associates, Architects & Engineers, San Diego, Calif.
 Hudson Extrusions, Inc., Hudson, Ohio

Induplas, Inc., Ponce, Puerto Rico
 International Pipe & Ceramics Corp., E. Orange, N.J.
 Iowa Concrete Products Co., Ames, Iowa

Japan Cotton Co., Dallas, Tex.

Kansas Plastics, Inc., Garden City, Kans.
 Kathan & Son, General Contractors, Inc., Onalaska, Wis.
 Kemp, Bunch & Jackson, Architects, Jacksonville, Fla.
 Kendall, J. B., Co., Washington, D.C.
 Kerona Plastic Extrusion Co., Stockton, Calif.
 Kerr-McGee Oil Industries, Inc., Oklahoma City, Okla.
 Kraloy/Chemtrol, Santa Ana, Calif.

La Favorite Rubber Manufacturing Co., Hawthorne, N.J.
 Landmark Engineering Co., Tucson, Ariz.
 Lusco Industries, Montebello, Calif.
 Littleton, Inc., Paducah, Ky.

Marion Supply Co., Marion, Ohio
 Marken Plastic Corp., Los Angeles, Calif.
 McDonald, A. Y., Manufacturing Co., Dubuque, Iowa
 Meyer, F. & J., New York, N.Y.
 Miller, Miller & Associates, Architects, Terre Haute, Ind. (General Support)
 Milnes, Kenneth W., A.I.A., Architect, Staten Island, N.Y.
 Mitron Research & Development Corp., Waltham, Mass.
 Monroe, Higgins & Lantow, Architects & Engineers, El Paso, Tex.
 Monsanto Co., Plastics Div., Springfield, Mass.
 Moore, George A., & Associates, Inc., Portland, Ore.

Nalgene Piping Systems, Div. of the Nalge Co., Inc., Rochester, N.Y.
 National Building Research Institute (C.S.I.R.), Pretoria, South Africa
 Naylor, A. D. & Co., Inc., Oakland, Md.
 North Dakota Concrete Products Co., Bismarck, N. Dak.

Ollinger-Jones Engineers, Merced, Calif.
 Orangeburg Manufacturing Co., Div. of The Flintkote Co., Orangeburg, N.Y.
 Osmose Wood Preserving Co. of America, Inc., Buffalo, N.Y.

Pacific Western Extruded Products, Inc., Downey, Calif.
 Panhandle Eastern Pipe Line Co., Kansas City, Mo.
 Pantasote Co., The, Passaic, N.J.
 Patzig Testing Laboratories, Inc., Des Moines, Iowa
 Pelletier, L. E., & Associates, Inc., Newtown, Conn.
 Perma Vinyl Corp., Miami, Fla.

Petro Plastics Co., Garwood, N.J.
 Plains Plastics, Inc., McPherson, Kans.
 Plastex Co., The, Columbus, Ohio
 Plastiline, Inc., Pompano Beach, Fla.
 Portco Corp., Paper & Plastic Div., Vancouver, Wash.
 Post, George B., & Sons, Architects, New York, N.Y.
 Pyramid Industries, Inc., Erie, Pa.

Raindrain Corp., Seattle, Wash.
 Republic Steel Corp., Cleveland, Ohio
 Richfield Oil Corp., Wilmington, Calif.
 Riverside Chemical Co., Inc., North Tonawanda, N.Y.
 Riverton Concrete Products, Riverton, Wyo.
 Robertson Heating Supply Co., Alliance, Ohio

Ryerson, Joseph T. & Son, Inc., Chicago, Ill., and Service Centers at Boston, Mass.; Buffalo, N.Y.; Charlotte, N.C.; Cincinnati, Cleveland, Ohio; Dallas, Tex.; Detroit, Mich.; Emeryville, Calif.; Houston, Tex.; Indianapolis, Ind.; Jersey City, N.J.; Los Angeles, Calif.; Milwaukee, Wis.; Philadelphia, Pittsburgh, Pa.; St. Louis, Mo.; Seattle, Spokane, Wash.; and Wallingford, Conn.

Schulman, A., Inc., Akron, Ohio
 Sears, Roebuck & Co., Chicago, Ill.
 Sechrist Chemicals, Inc., Bayonne, N.J.
 Sedco Manufacturing Co., Inc., Miami, Fla.
 Sekisui Chemical Co., Ltd., Osaka, Japan
 Sekisui New York Corp., New York, N.Y.
 Skyline Industries, Inc., Titusville, Pa.
 Soult Wholesale Co., Clearfield, Pa.
 South Dakota Concrete Products Co., Watertown, S. Dak.
 Southeast Distributing Co., Inc., Miami, Fla.
 Southern California Gas Co., Los Angeles, Calif.
 Stauffer Chemical Co., Molded Products Div., Los Angeles, Calif.
 Sterling Faucet Co., Morgantown, W. Va.
 Stokes Molded Products, Trenton, N.J.
 Swanson Co., The, Fresno, Calif.

Tampa Wholesale Plumbing Supply Corp., Tampa, Fla.
 Telsco Industries, Dallas, Tex.
 Texas State Board of Plumbing Examiners, Austin, Tex.
 Thermoplastics Corp., Charlotte, N.C.
 Thokol Chemical Corp., Trenton, N.J.

UPO Chemical Co., A Div. of Universal Oil Products, Co., East Rutherford, N.J.
 Union Carbide Corp., Plastics Div., New York, N.Y.
 Union Malleable Manufacturing Co., Plastics Div., Ashland, Ohio
 United Pipe & Supply Co., Inc., Eugene, Ore.
 United States Industrial Chemical Co., Polymer Service Laboratory, Tuscola, Ill.
 United States Pipe & Foundry Co., Plastic Div., Miami, Fla.
 United States Testing Co., Inc., Hoboken, N.J.
 United Supply Co., Vancouver, Wash.
 Uyesaka Brothers, Inc., Clovis, Calif.

Vogel, Willis A., Architect & Consultant, Toledo, Ohio
 Vulcan-Cincinnati, Inc., Cincinnati, Ohio

Welch, Carroll E., Architect, Huntington, N.Y.
 Western Industries, Inc., of Oklahoma, Tulsa, Okla.
 Western Plastic Corp., Hastings, Nebr.
 Western Plastics Corp., Tacoma, Wash.
 Wigton-Abbott Corp., Plainfield, N.J.
 Williams & Associates-Irrigation Consultants, Oakland, Calif. (General Support)

GOVERNMENT

U.S. Army, Picatinny Arsenal, Ammunition Engineering Directorate, Dover, N.J.

General Services Administration, Standard- | Interior, Department of the Office of the
ization Division, Hardware & Construc- | Secretary, Division of Property & Rec-
tion Branch, Washington, D.C. (General | ords, Washington, D.C.
Support)

OTHER COMMERCIAL STANDARDS

A list of Commercial Standards and Simplified Practice Recommendations may be obtained from the Office of Commodity Standards, National Bureau of Standards, U.S. Department of Commerce, Washington, D.C., 20234. This list includes the purchase price of each publication and gives directions for ordering copies.

ACCEPTANCE OF COMMERCIAL STANDARD

**CS 272-65 POLYVINYL CHLORIDE (PVC) PLASTIC DRAIN, WASTE,
AND VENT PIPE AND FITTINGS**

If acceptance has not previously been filed, this sheet properly filled in, signed, and returned will provide for the recording of your organization as an acceptor of this Commercial Standard.

Date _____

Office of Commodity Standards
National Bureau of Standards
U.S. Department of Commerce
Washington, D.C., 20234

Gentlemen:

We believe that this Commercial Standard constitutes a useful standard of practice, and we individually plan to utilize it as far as practicable in the

production¹ distribution¹ purchase¹ testing¹
of this commodity.

We reserve the right to depart from the standard as we deem advisable.

We understand, of course, that only those articles which actually comply with the standard in all respects can be identified or labeled as conforming thereto.

Signature of authorized officer _____
(In Ink)

(Kindly typewrite or print the following lines)

Name and title of above officer _____

Organization _____
(Fill in exactly as it should be listed)

Street Address _____

City, State, and Zip Code _____

¹ Underscore the applicable words. Please see that separate acceptances are filed for all subsidiary companies and affiliates which should be listed separately as acceptors. In the case of related interests, trade association, trade papers, etc., desiring to record their general support, the words "General Support" should be added after the signature.

(Cut on this line)

TO THE ACCEPTOR

The following statements answer the usual questions arising in connection with the acceptance and its significance:

1. *Enforcement.*—Commercial Standards are commodity specifications voluntarily established by mutual consent of those concerned. They present a common basis of understanding between the producer, distributor, and consumer and should not be confused with any plan of governmental regulation or control. The United States Department of Commerce has no regulatory power in the enforcement of their provisions, but since they represent the will of the interested groups as a whole, their provisions through usage soon become established as trade customs, and are made effective through incorporation into sales contracts by means of labels, invoices, and the like.

2. *The acceptor's responsibility.*—The purpose of Commercial Standards is to establish, for specific commodities, nationally recognized grades or consumer criteria, and the benefits therefrom will be measurable in direct proportion to their general recognition and actual use. Instances will occur when it may be necessary to deviate from the standard and the signing of an acceptance does not preclude such departures; however, such signature indicates an intention to follow the standard, where practicable, in the production, distribution, or consumption of the article in question.

3. *The Department's responsibility.*—The major function, performed by the Department of Commerce in the voluntary establishment of Commercial Standards on a nationwide basis is fourfold: First, to act as an unbiased coordinator to bring all interested parties together for the mutually satisfactory adjustment of trade standards; second, to supply such assistance and advice as past experience with similar programs may suggest; third, to canvas and record to the extent of acceptance and adherence to the standard on the part of producers, distributors, and users; and fourth, after acceptance, to publish the standard for the information and guidance of buyers and sellers of the commodity.

4. *Announcement and promulgation.*—When the standard has been endorsed by a satisfactory majority of production or consumption in the absence of active, valid opposition, the success of the project is announced. If, however, in the opinion of the standing committee or of the Department of Commerce, the support of any standard is inadequate, the right is reserved to withhold promulgation and publication.