

~~CONFIDENTIAL~~  
**UNCLASSIFIED**

WT-1358

Copy No. 17 B

960.2

019692

*Operation*

# **REDWING**

**PACIFIC PROVING GROUNDS**

May - July 1956

Project 31.2

**RELEASE TONE SYSTEM**

Issuance Date: September 20, 1957

**RETURN TO L-D**

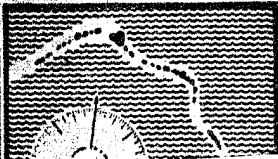

**DISTRIBUTION STATEMENT B**  
Approved for public release  
Distribution Unlimited

This material contains information affecting the national defense of the United States within the meaning of the espionage laws Title 18, U. S. C., Secs. 793 and 794, the transmission or revelation of which in any manner to an unauthorized person is prohibited by law.

19960702 080

Classification (Cancelled) (Changed to UNCL)  
By Authority of TID 1400 52  
By Angela Karamis Date 7-23-76

**JOINT TASK FORCE SEVEN**

**UNCLASSIFIED**

DISTRIBUTION STATEMENT A APPLIES  
PER NTPR REVIEW.

*[Signature]* DATE *8/2/57*

15

~~CONFIDENTIAL~~  
**UNCLASSIFIED**

# DISCLAIMER NOTICE



**THIS DOCUMENT IS BEST QUALITY AVAILABLE. THE COPY FURNISHED TO DTIC CONTAINED A SIGNIFICANT NUMBER OF PAGES WHICH DO NOT REPRODUCE LEGIBLY.**

This report supersedes WT-1358(Prelim.), Series A. Holders of WT-1358(Prelim.) should destroy copies in accordance with existing security regulations. Destruction certificates should be forwarded to the Sandia Corporation, Albuquerque, N. Mex.

If WT-1358, Series B, is no longer needed, return it to  
AEC Technical Information Service Extension  
P. O. Box 401  
Oak Ridge, Tennessee



Defense Nuclear Agency  
6801 Telegraph Road  
Alexandria, Virginia 22310-3398

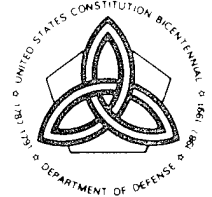

ISST

29 January 1996

MEMORANDUM FOR DEFENSE TECHNICAL INFORMATION CENTER  
ATTENTION: OCD/Mr. Bill Bush

SUBJECT: Declassification of WT-1358

The following report can be released under distribution statement "A" per the evaluation of the Defense Nuclear Agency Security Office (OPSSI):

WT-1358  
Operation REDWING, Pacific Proving Grounds  
May-July 1956  
Project 31.2, Release Tone System.

A copy is included for your use. Please notify this office of your assigned accession number.

Enclosure:  
A/S

*for Anita Garrett*

JOSEPHINE B. WOOD  
Chief, Technical Support Branch

8-1109

*Handwritten signature*

[REDACTED]

WT-1358

This document consists of 35 pages  
No. 17 of 85 copies, Series B

UNCLASSIFIED

Report to the Scientific Director

# RELEASE TONE SYSTEM

By  
Billy M. Ray  
and  
Robert J. Scussel

Sandia Corporation  
Albuquerque, New Mexico  
February 1957

DISTRIBUTION STATEMENT A  
Approved for public release  
Distribution Unlimited

This material contains information affecting  
the national defense of the United States  
within the meaning of the espionage laws  
Title 18, U. S. C., Secs. 793 and 794, the  
transmission or revelation of which in any  
manner to an unauthorized person is pro-  
hibited by law.



[REDACTED]

UNCLASSIFIED

[REDACTED]

UNCLASSIFIED

**ABSTRACT**

This report describes in detail the operation and components of a frequency shift/frequency modulation system which provides telemetering of bomb release time from an aircraft to a ground station.

UNCLASSIFIED

[REDACTED]

[REDACTED]

UNCLASSIFIED

CONTENTS

	Page
ABSTRACT	3
1 OBJECTIVE	7
2 BACKGROUND	7
3 DESCRIPTION	7
3.1 General	7
3.2 Operation of Airborne Equipment	16
3.3 System Delay Time	17
3.4 Advantage of FS/FM	18
4 OPERATIONS	18
4.1 Checkout	18
4.2 Live Runs	25
5 INSTRUMENTATION	25
5.1 Airborne Equipment	25
5.2 Ground-station Equipment	25
6 RESULTS	28
6.1 Conclusions and Recommendations	28
APPENDIX I	29
APPENDIX II	34
ILLUSTRATIONS	
1 Airborne Transmitter	8
2 Ground-station Equipment, Front View—Nan	9
3 Ground-station Equipment, Rear View	10
4 Release Tone System, Basic Block Diagram	11
5 Release Tone System, Block Diagram	13
6 Oscillograph Record of Noise Only	15
7 Oscillograph Record of Preflyaround Test	16
8 Oscillograph Record of Flyaround Test	17

UNCLASSIFIED

[REDACTED]

UNCLASSIFIED

~~CONFIDENTIAL~~

UNCLASSIFIED

ILLUSTRATIONS (Continued)

	Page
9 Pole-mounted Antennas	19
10 Wiring Diagram, Rack No. 1	21
11 Wiring Diagram, Rack No. 2	22-23
12 Antennas and Mounts	27

~~CONFIDENTIAL~~

UNCLASSIFIED

~~CONFIDENTIAL~~

UNCLASSIFIED

## RELEASE TONE SYSTEM

### 1 OBJECTIVE

Accurate telemetry of bomb release time is necessary on airdrops to start an Edgerton, Germeshausen, and Grier (EG&G) sequence timer referenced to burst time. Therefore, a dependable system of ensuring such telemetry is required. The release tone system is a frequency shift/frequency modulation (FS/FM) system devised to provide a relay contact closure for starting the sequence timer at the instant of bomb release in an airdrop. In addition, this system measures the time of fall by recording both release and detonation sequentially on an oscillograph record.

### 2 BACKGROUND

Formerly, in telemetering bomb release, an amplitude modulation/frequency modulation (AM/FM) system was employed in which the VCO was muted at release. Thus, the timer-start relay operated on a go/no-go basis, the presence of tone signifying "ready" and the absence of tone signifying "release." But this system had the following disadvantages:

1. Limited signal-to-noise operating ability. Noise tended to obscure the signal.
2. In the absence of radio-frequency (r-f) signal, noise tended to cause false operation; integrated bursts of noise caused the relay to operate.

To overcome the difficulties encountered in the AM/FM system, the present FS/FM system was devised.

### 3 DESCRIPTION

#### 3.1 General

The release tone system, consisting of standard telemetering units described in detail in Appendix A, operates on a frequency shift and employs two separate and independent channels in parallel. For each channel, bomb release shifts the frequency of a subcarrier oscillator whose output modulates an airborne transmitter (Fig. 1). At the ground station (Figs. 2 and 3) an FM receiver delivers this shifted signal to a subcarrier discriminator. The discriminator, in turn, feeds a biased polarized relay which responds only to a positive discriminator output (Fig. 4). These r-f channels operate on 217.5 and 220.5 mc, and each channel has full standby spares. The operation of either channel is sufficient to ensure the functioning of the system (Fig. 5) under any of the three possible conditions: (1) ready, (2) channel failure, and (3) release. Only in the last condition does the timer-start relay operate.

UNCLASSIFIED

~~CONFIDENTIAL~~

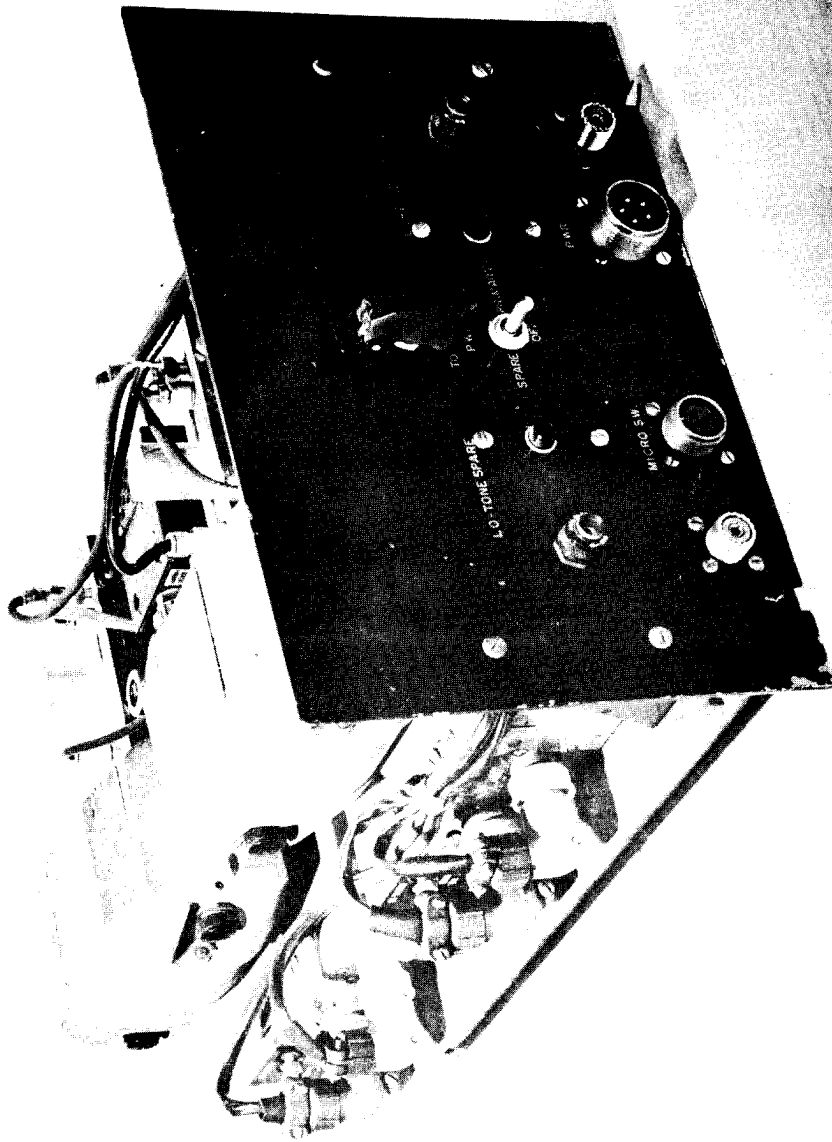

Fig. 1 -- Airborne Transmitter

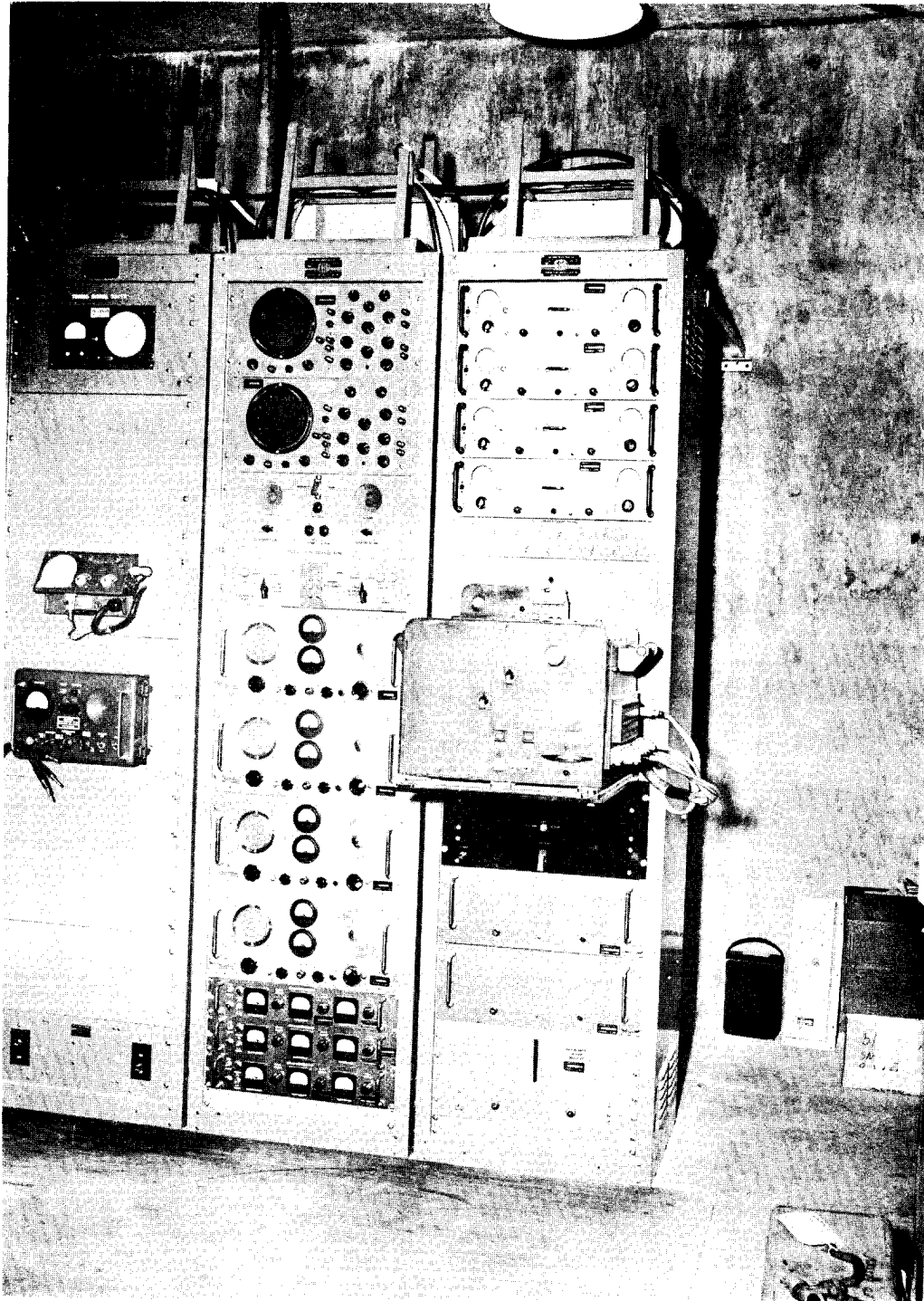

Fig. 2 -- Ground-station Equipment, Front View--Nan

~~CONFIDENTIAL~~

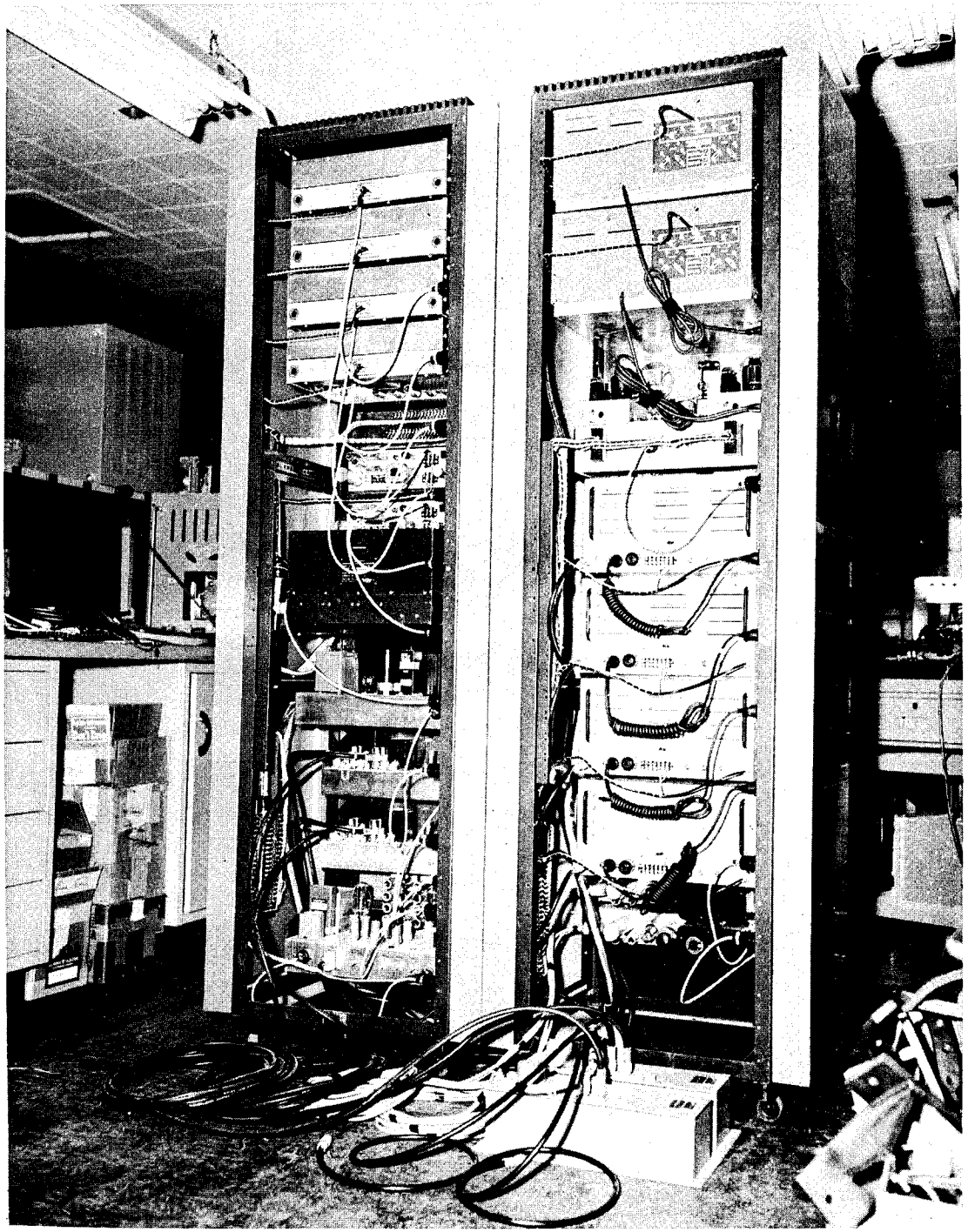

Fig. 3 -- Ground-station Equipment, Rear View

UNCLASSIFIED

~~CONFIDENTIAL~~

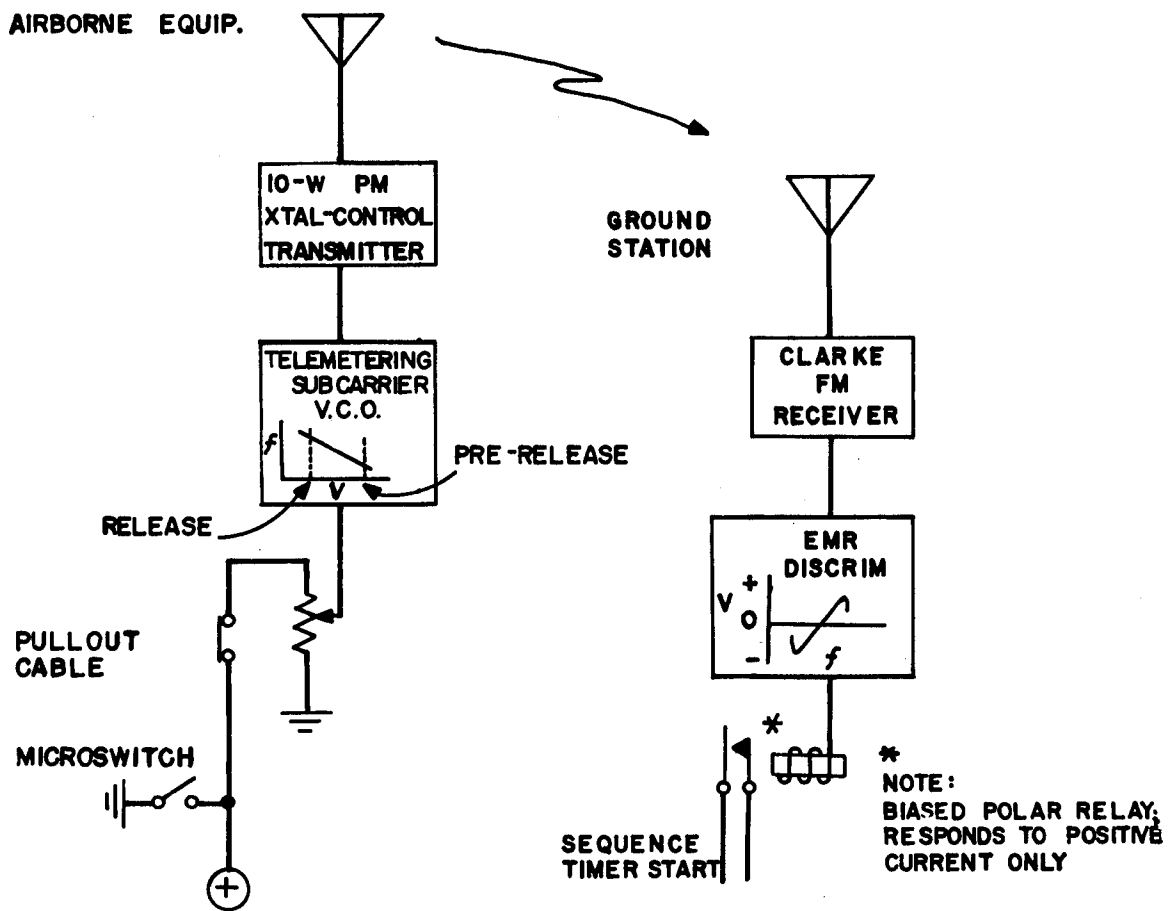
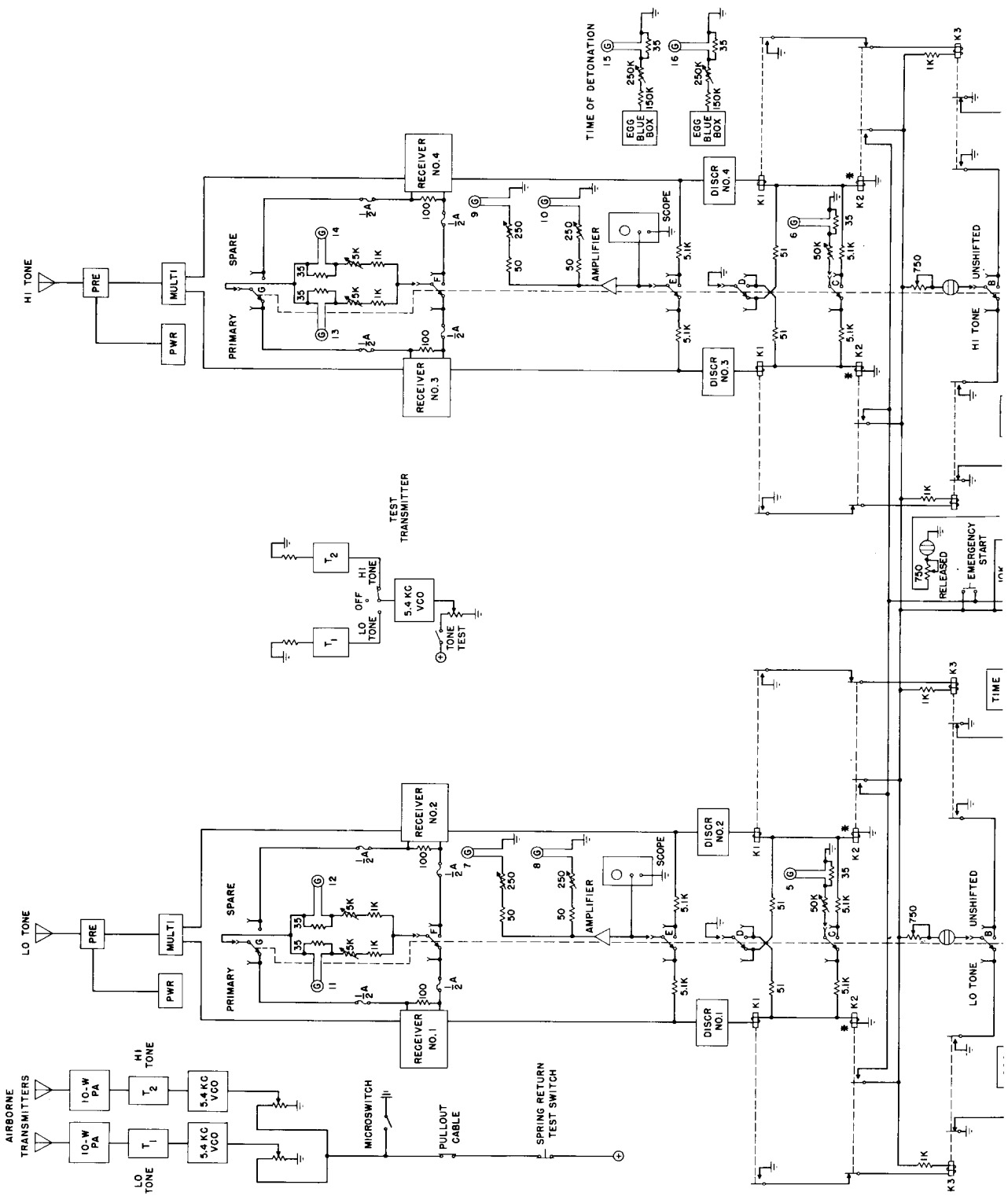

Fig. 4 -- Release Tone System, Basic Block Diagram



UNCLASSIFIED

CONFIDENTIAL



[REDACTED]

UNCLASSIFIED

### 3.1.1 Ready Condition

Before bomb release, approximately 3 volts is continuously applied to the voltage-controlled oscillator (VCO) in the airborne unit, causing the transmission of an FM signal modulated by approximately 5000 cycles. Reception of this signal by the ground station FM receivers causes negative output current from the subcarrier discriminators. Negative discriminator current merely reinforces the holding force on the normally open biased polar relay used to start the sequence timer. Thus, the timer-start relay contact remains in its normal open condition. However, a plain relay in series with the polar relay coil is also energized by the discriminator current and gives ready indication via lamps and speaker output. Concurrently, the oscilloscopes show 3 cycles of the FM receiver output.

If desired, the 5000 cycles from the receiver may be monitored on the receiver internal speaker by simply turning up the receiver audio gain.

### 3.1.2 Channel Failure

In case the r-f signal is lost, the discriminator output drops to zero (average). The polarized timer-start relay then remains in its normal open condition, since it responds only to positive current. Thus, noise alone does not start the timer (Fig. 6). However, in the absence of signal, the plain indicating relay will drop out and chatter, causing definite and observable flickering of the ready lamps and speaker signal. Also, the scope pattern will change to noise and, if the internal speaker on the receiver is being monitored, noise will be heard there. Thus, channel failure is clearly indicated, but without danger of false operation.

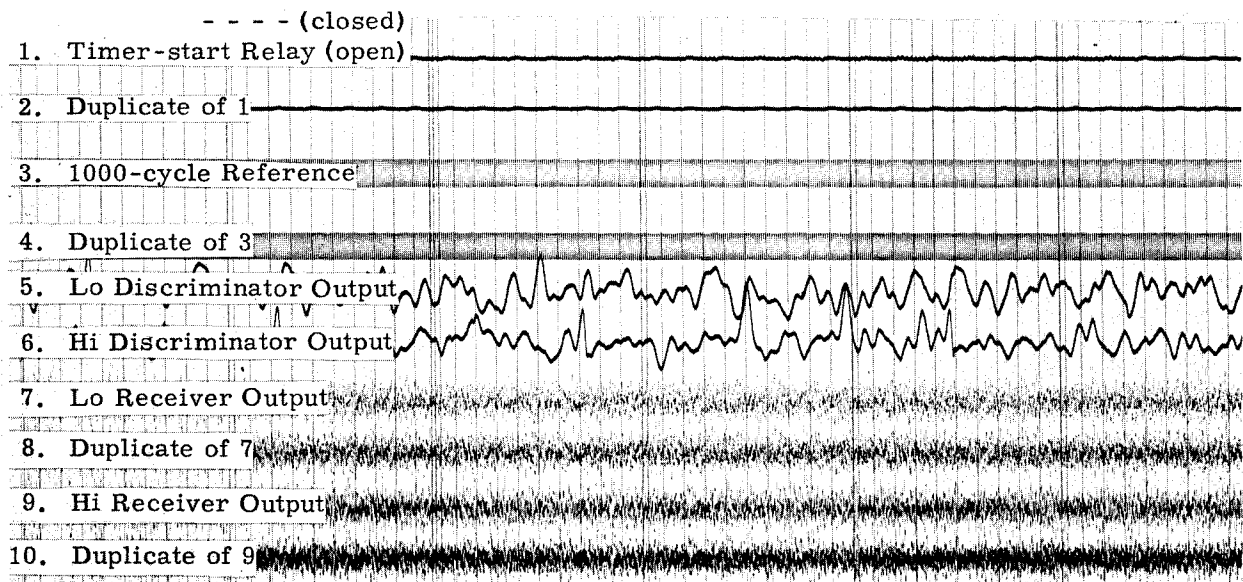

Fig. 6 -- Oscillograph Record of Noise Only

[REDACTED]

UNCLASSIFIED

CONFIDENTIAL

### 3.1.3 Release Condition

At release, the 3 volts to the VCO is grounded by the two microswitches which had been held open by the drop unit. (In case of microswitch failure, the unit pullout plug will open the 3 volts.) Interruption of the 3 volts causes the VCO to shift to approximately 5800 cycles. At the ground station the application of 5800 cycles to the discriminator causes positive current to be applied to the polar relay. The polar relay then operates, closing the timer-start circuit and lighting the released lamp. Operation of the polar relay also interrupts the circuit of the plain relay, thereby extinguishing the ready lamps and muting the 1000-cycle speakers on the control panel. Concurrently, the oscilloscope patterns shift to show 4 cycles of the FM receiver outputs. Also, the shift can be heard on the internal speaker of the receiver if desired.

### 3.2 Operation of Airborne Equipment

In the Sandia Base and Kirtland Air Force Base (KAFB) area in New Mexico, a ground station was set up and was complete except that a corner reflector was used in place of helical antennas which were unavailable. The one antenna fed one preamplifier and multicoupler which, in turn, fed all four receivers. A Carco airplane was employed to carry the airborne equipment which, instead of the usual 10-watt transmitter, consisted of a 2-watt transmitter keyed by a motor-driven keyer. Figure 7 shows consistent proper operation of the system, with the airplane still on the KAFB runway and with the improvised corner reflector at Sandia Base aimed 90 degrees from the aircraft. The airplane deployed generally about 10 to 20 miles south of the Sandia Base Tech Area, but made one flight to approximately 50 miles away from this area. Receiver signal strength was generally 1000 to 10,000  $\mu\text{v}$ , momentarily dropping to 100 to 200  $\mu\text{v}$  at the extreme end of the 50-mile flight.

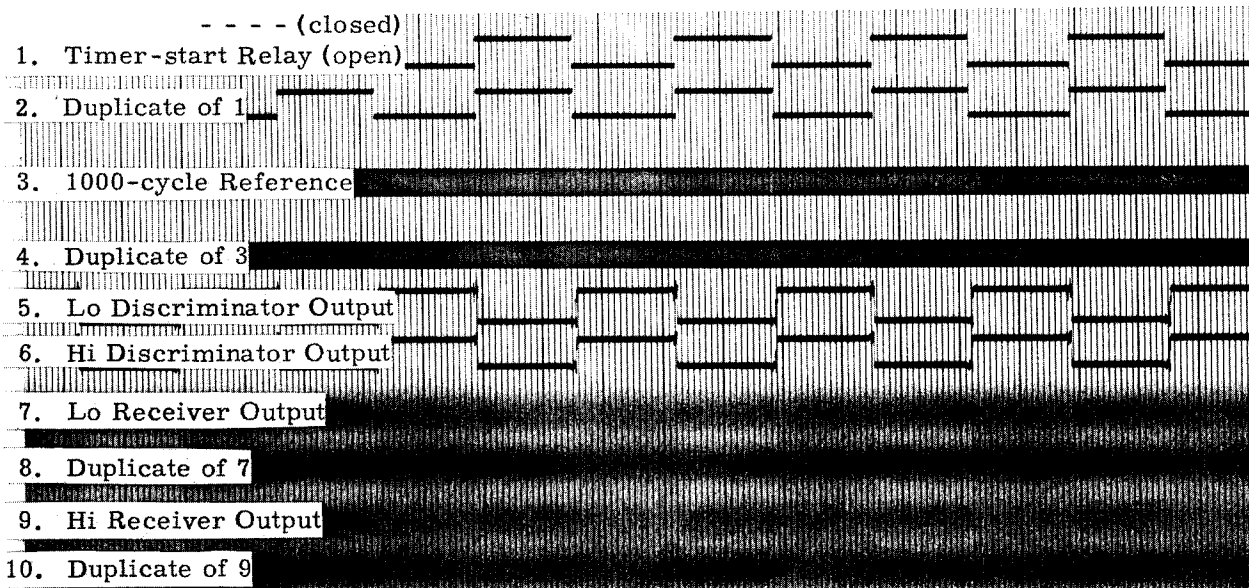

Fig. 7 -- Oscillograph Record of Preflyaround Test

CONFIDENTIAL

UNCLASSIFIED

A paper recording (Fig. 8) was made of the entire flight, and more than 1300 consecutive operations were completed satisfactorily without malfunction. This flyaround was considered to be entirely satisfactory.

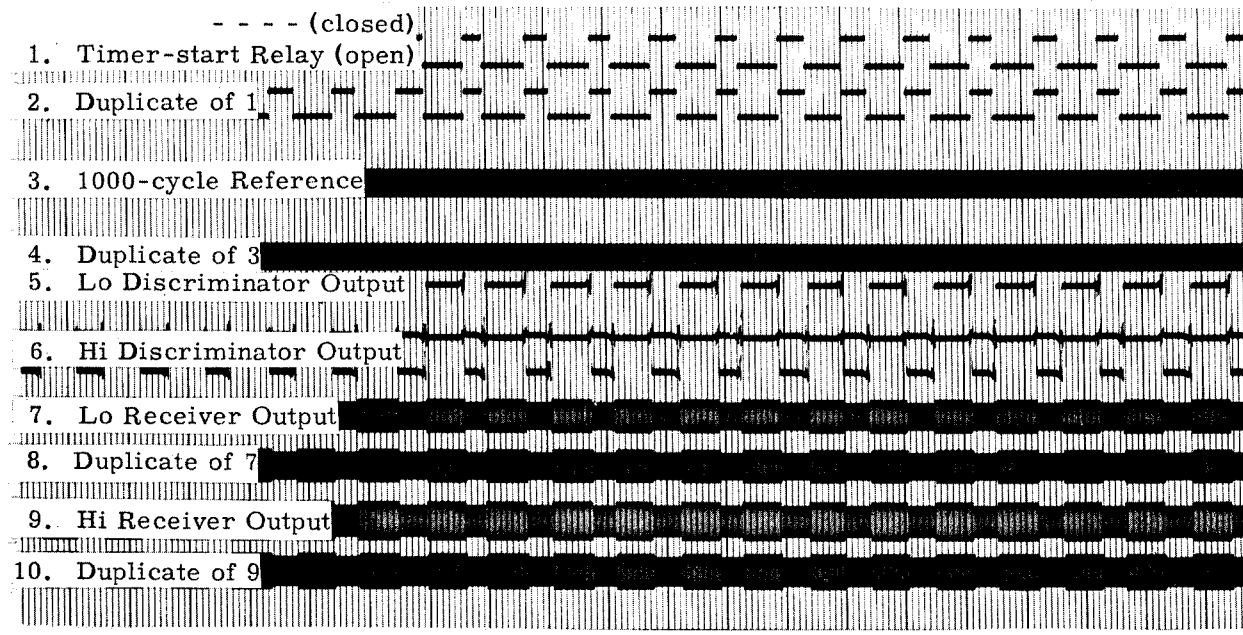

Fig. 8 -- Oscillograph Record of Flyaround Test

Two identical prototypes of airborne equipment were fabricated about July 1955 and were operated several months in a Navy plane. Reports indicate that there has been no failure of the equipment and that the Navy is satisfied with the continued operation. Signal strength tests were conducted at Salton Sea Test Base (SSTB) in September 1955. At maximum range (40,000 ft altitude, 80 miles from the SSTB control point) signal strength was 1000  $\mu$ v. The signal dropped to 100  $\mu$ v when the plane was in a turn and the antenna was shielded by the aircraft itself. At no time was the discriminator signal lost.

### 3.3 System Delay Time

A time delay exists between the time that the VCO voltage is removed and the time that the polar relay closes the sequence timer start circuit. For 90 per cent of the operations, the delay time will be  $50 \pm 1$  msec. To permit 100 per-cent coverage, a delay of  $50 \pm 3$  msec will be allowed. When the EG&G relay, type DN-11, is used on the output of the polar relay, an additional delay of approximately 0.05 sec occurs, making a total delay of approximately 0.1 sec.

There is a negligible time delay (less than 1 msec) between the time that the VCO voltage is removed and the time that the FM receiver output signal shifts frequency.

UNCLASSIFIED

### 3.4 Advantages of FS/FM

#### 3.4.1 Signal-to-noise Ratio

Frequency shift has a theoretical advantage of 10 to 14 db over an AM system,<sup>1/</sup> and comparative field tests have borne out this theory.<sup>2/</sup>

#### 3.4.2 Relative Insensitivity to Noise

The relative insensitivity to noise in the absence of signal is due to the averaging effect of the discriminator. Within the pass band of the discriminator, random noise tends to produce as many components below the center frequency of the discriminator as above center. Therefore, the integrated results tend toward zero.

In this particular equipment setup, a biased polar relay is used in the discriminator output. Since this relay is biased to the "off" condition, it enhances the inherent noise-averaging characteristic of the subcarrier discriminator. Thus, the relay does not operate at all in the presence of full receiver noise. Appendix B lists the items of the FS/FM system which could fail without affecting proper operation of the timer-start relay and the items which are essential to proper operation.

#### 3.4.3 Nonambiguous Operational Conditions

The conditions of ready, release, and channel failure are separate and distinct because the VCO output is at 5000 cycles, at 5800 cycles, or the signal is absent.

## 4 OPERATIONS

### 4.1 Checkout

In late March 1956, Sandia Corporation personnel began to set up the ground stations on Elmer and Nan at Eniwetok Proving Grounds for the release tone system operations during the Redwing series. Power (a-c) was brought in to both ground stations, and the antennas were installed and oriented.

For the Cherokee drop, the Nan ground station antennas were mounted at 30- and 45-ft levels on the north leg of the steel tower close to Station 70 concrete bunker. The J-3 flight plans indicated that antenna azimuth of 355 degrees and elevation of 20 degrees would cover the entire approach path of the aircraft, including a 20 per-cent additional area beyond release point. A similar arrangement was established outside Station 311 on Site Elmer for the Osage drop. Antennas were pole mounted at approximately 20- and 35-ft elevations on a wood pole outside the control point (Fig. 9). Meanwhile, EG&G-provided equipment, including two racks, two "blue-boxes," a DN-11 relay, and a 125-volt d-c source, had arrived at each station. Rack cables (Figs. 10 and 11), prefabricated at Sandia Corporation, were connected, and the entire transmitting and receiving equipment was given a thorough test run. The test transmitter was then moved to a location one-half mile distant, and the tests were repeated. The entire ground system checked out satisfactorily.

The airborne transmitters were installed in the aircraft and, when the aircraft happened to be in the vicinity of the operation, impromptu flyaround checks were made. The signal faded rapidly when the aircraft was in a turn preceding approach. However, the signal was satisfactory for more than the last 2 min of approach and 1 min or more after release.

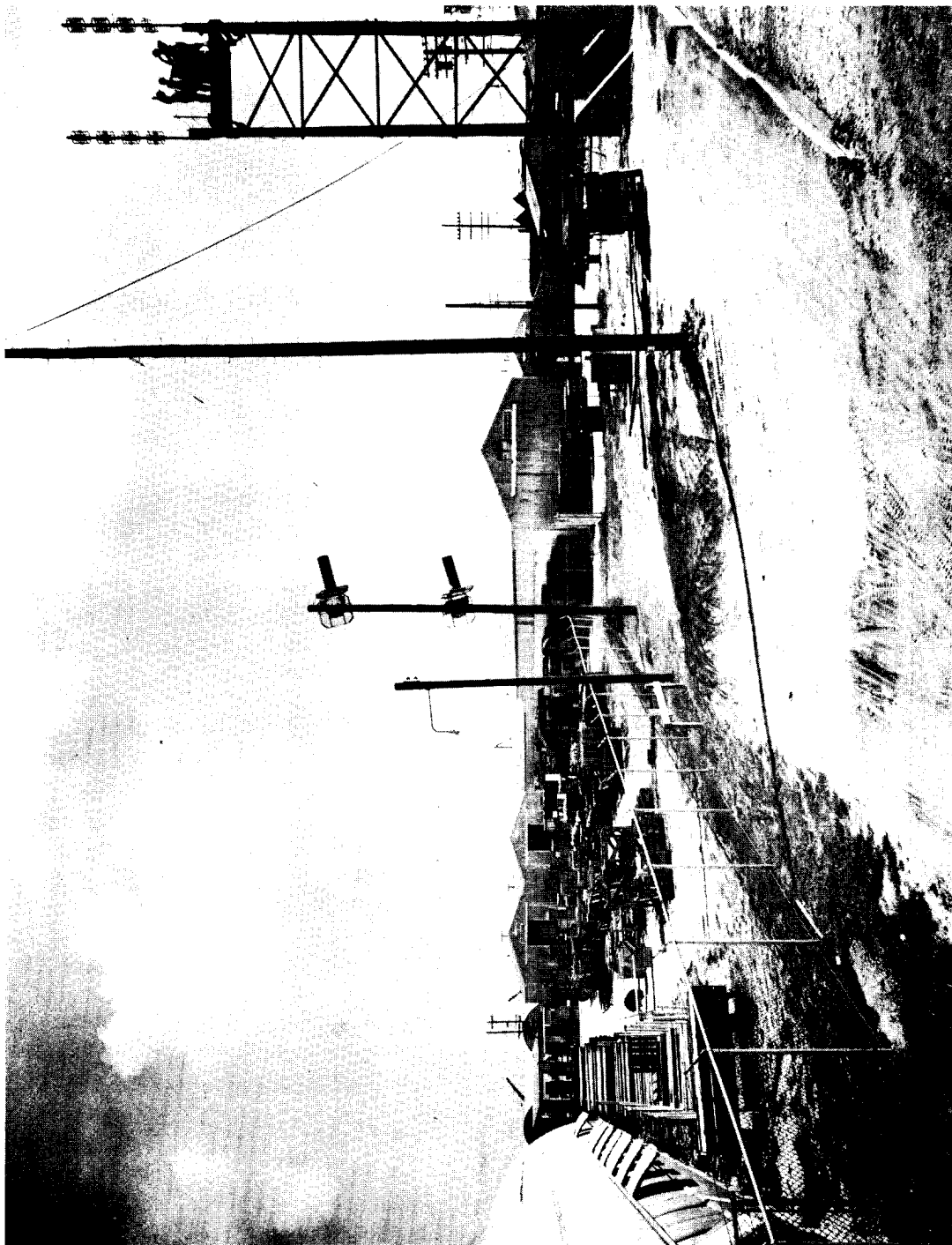
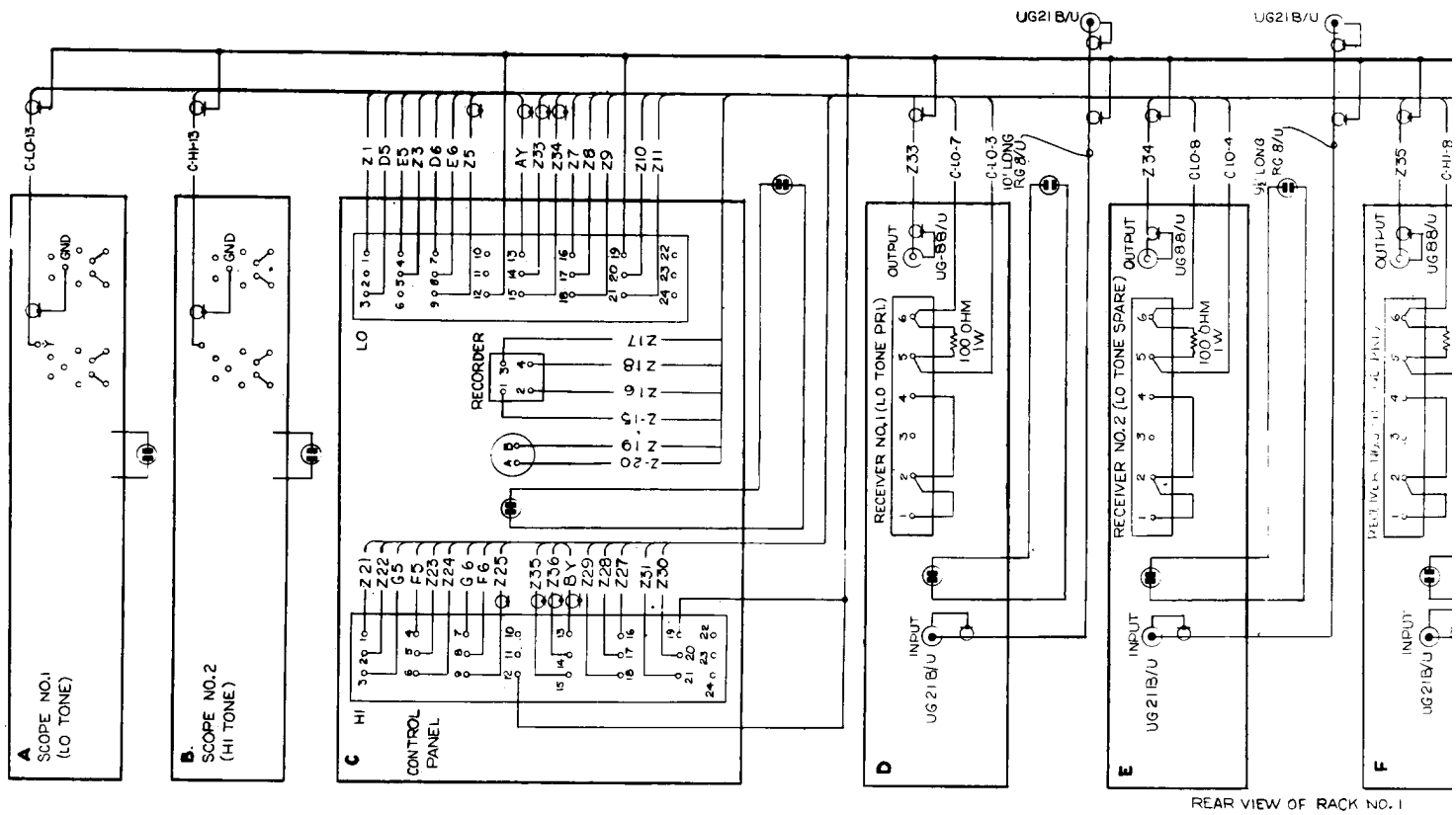

Fig. 9 -- Pole-mounted Antennas

UNCLASSIFIED



REAR VIEW OF RACK NO. 1

Fig. 10 -- Wiring

UNCLASSIFIED

NOTES:

1. COAXIAL CABLE, UNLESS OTHERWISE NOTED USE EITHER RG 58/U (UG21B/U) OR RG 62/U (UG260 B/U).
2. POWER CORD LONG ENOUGH TO REACH OUTLET STRIP VERTICALLY MOUNTED ALONG INSIDE RIGHT (FROM REAR) REAR OF RACK.
3. Z RACK TERMINALS, TEMPORARILY INSTALL TWO 20 POINT JONES BARRIER STRIPS NO.141,GS\*625669.
4. ALL UNMARKED WIRE TO BE NO.18 STRANDED COPPER WIRE WHITE VINYLITE COVERED.
5. C-LO-13 - WIRE DESTINATION INFORMATION.

TO Z TERMINALS IN RACK NO 2

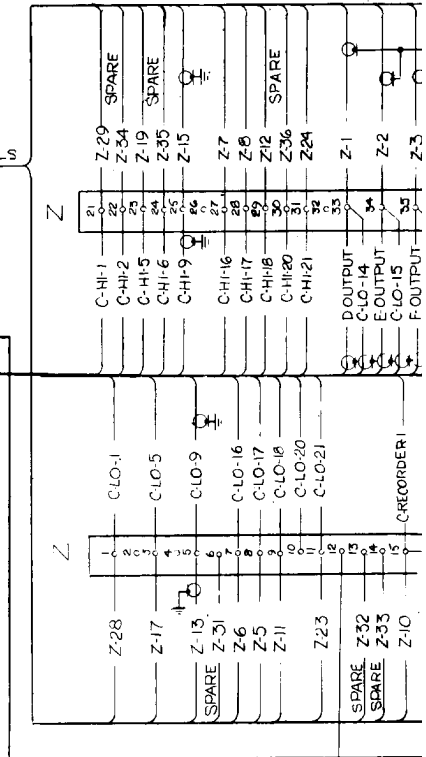
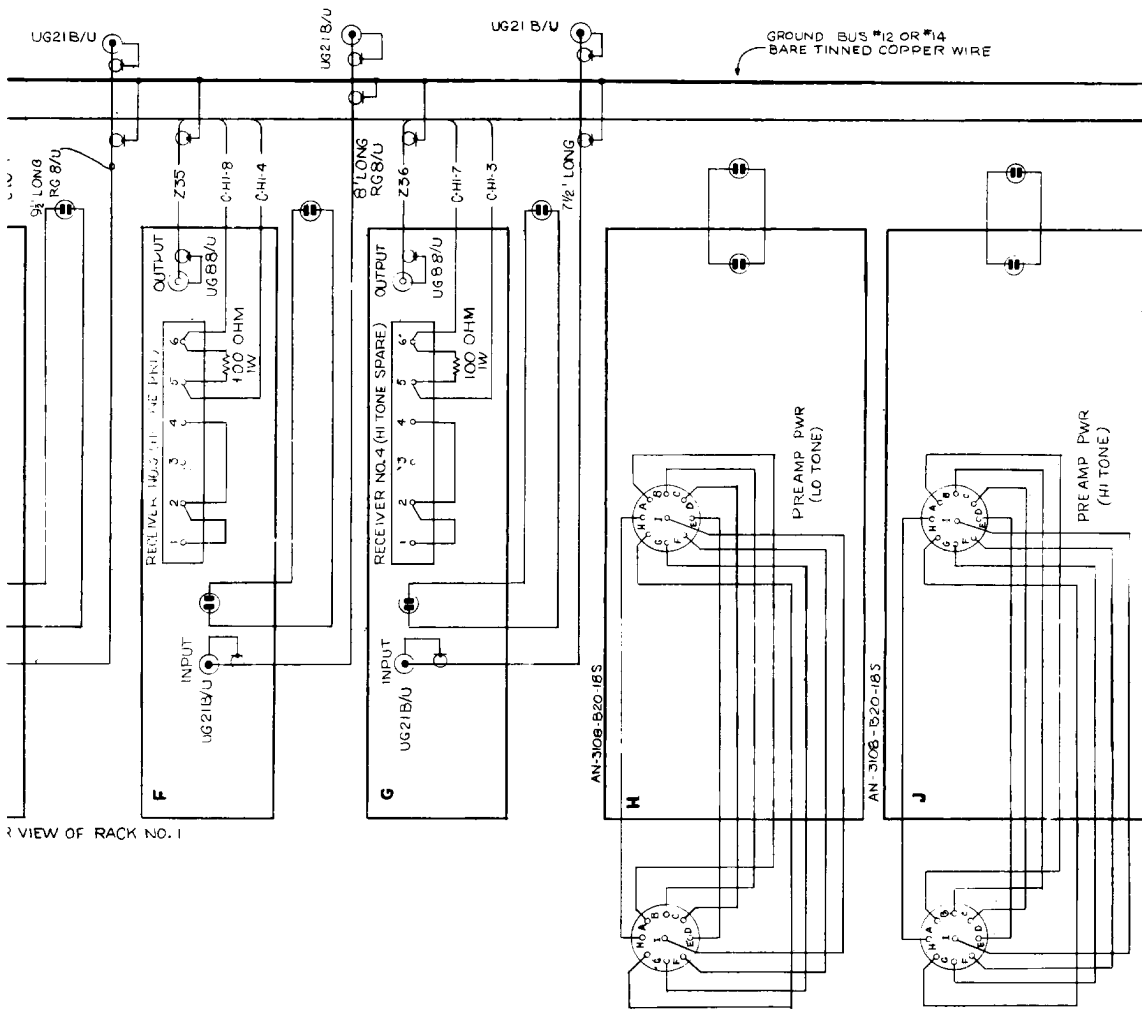

VIEW OF RACK NO. 1

Fig. 10 -- Wiring Diagram, Rack No. 1



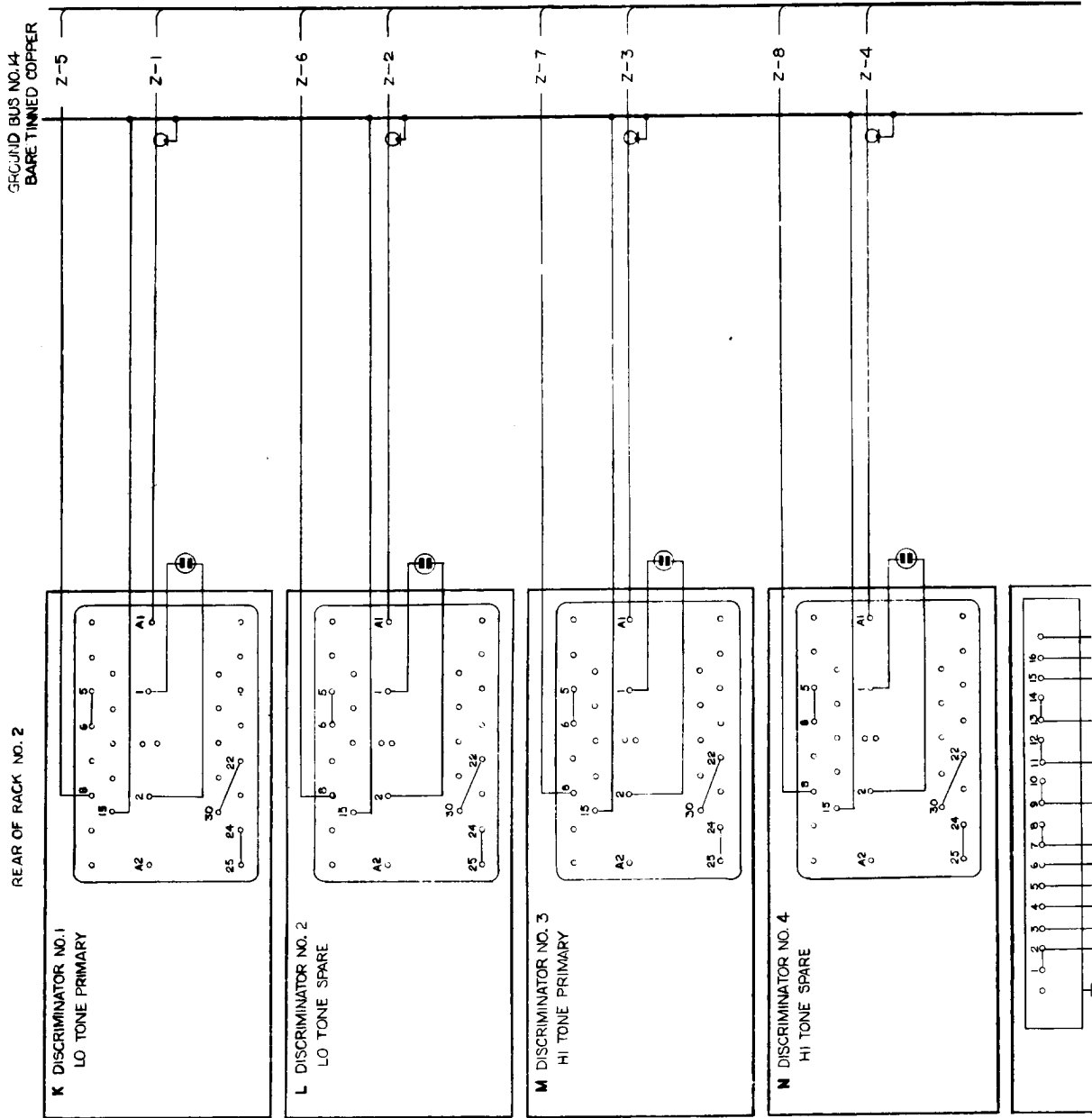

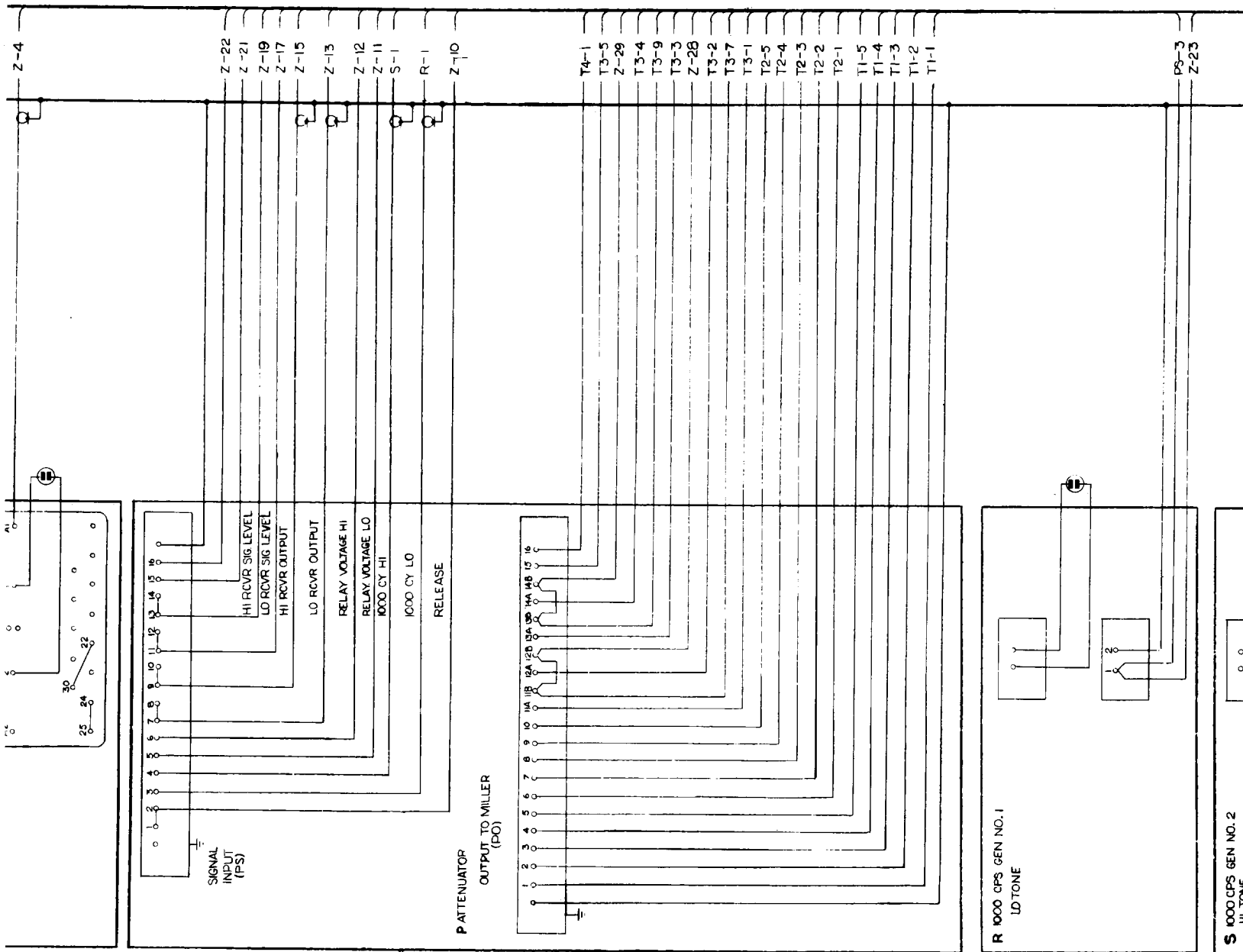

**R** 1000 CPS GEN NO.1  
LD TONE

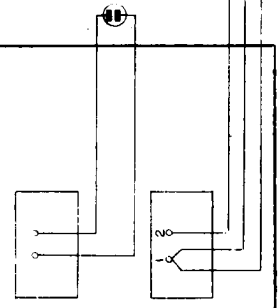

PS-3  
Z-23

**S** 1000 CPS GEN NO.2  
HI TONE

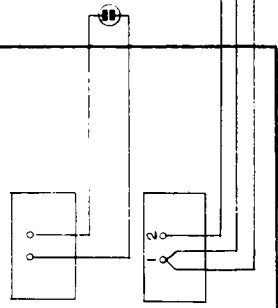

PS-4  
Z-24

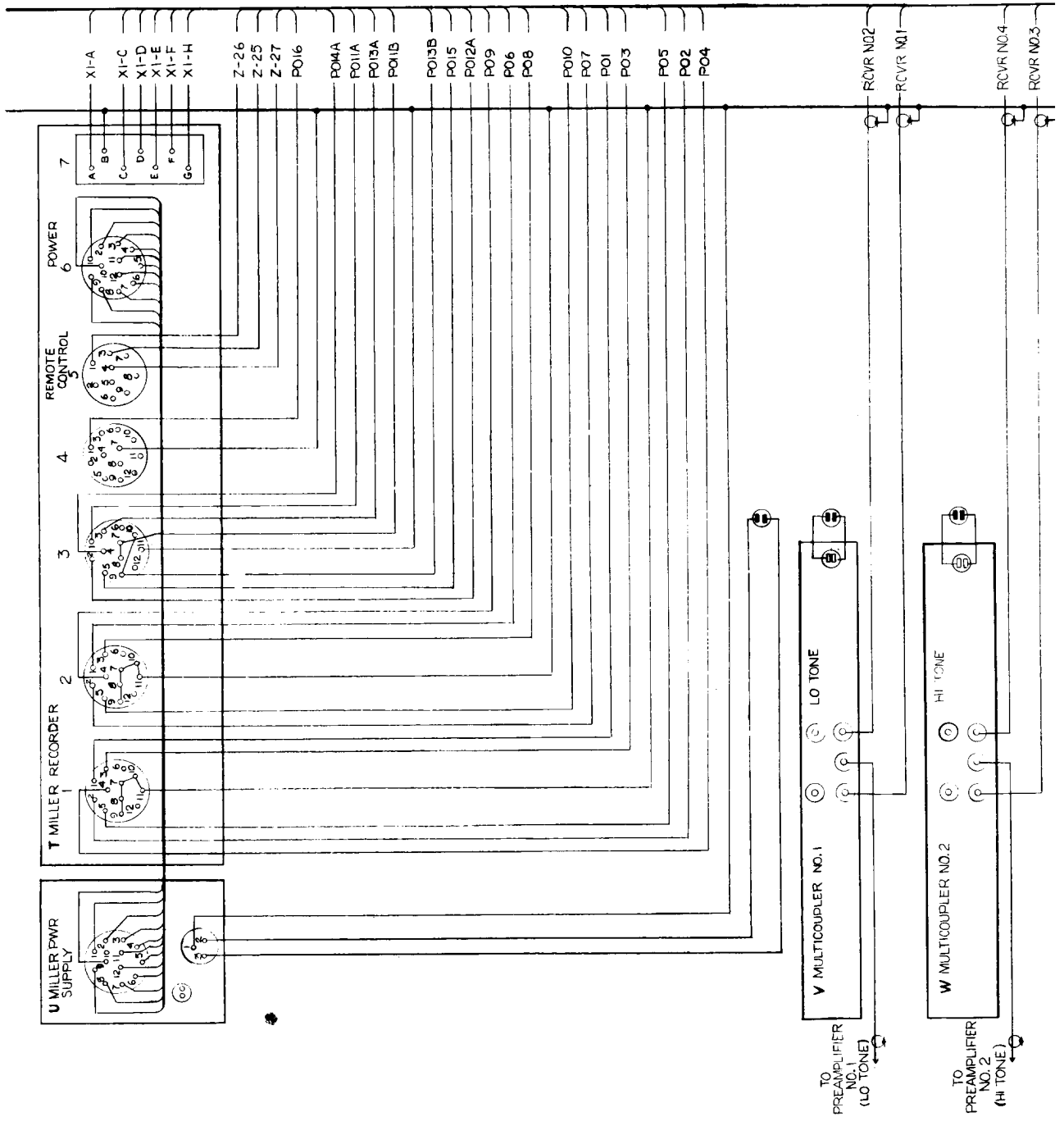
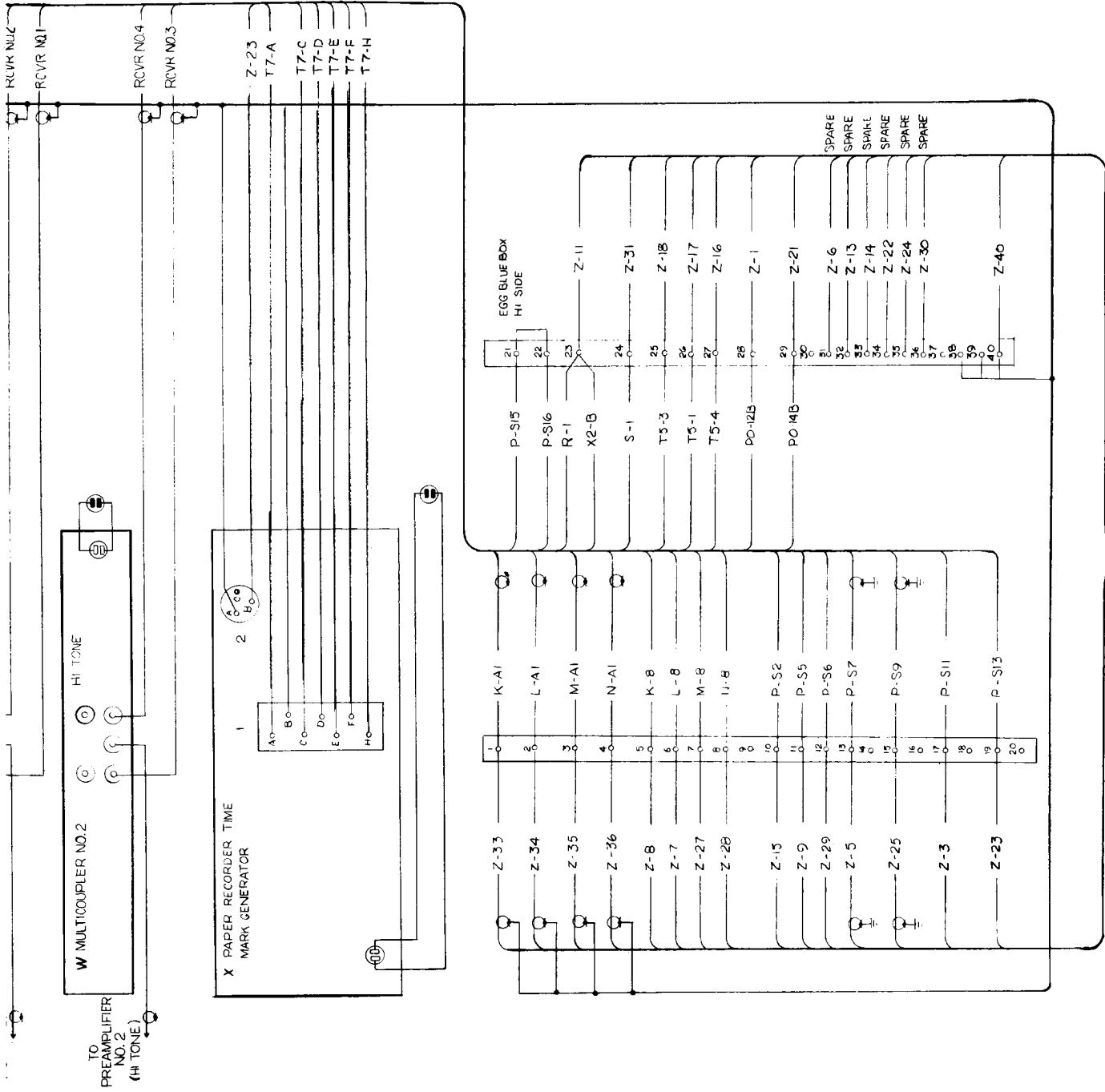

Fig. 11 -- Wiring Di



NOTES:

1. COAXIAL CABLE; UNLESS OTHERWISE NOTED, USE EITHER RG 58/U (UG21B/U) OR RG42/U (UG260B/U).
2. POWER CORD LONG ENOUGH TO REACH OUTLET STRIP VERTICALLY MOUNTED ALONG INSIDE RIGHT (FROM REAR OF RACK) REAR OF RACK.
3. Z RACK TERMINALS 20-POINT JONES BARRIER STRIPS NO. 20-141 GS NO. 625669.

TO Z TERMINALS  
IN RACK NO. 1

. 11 -- Wiring Diagram, Rack No. 2

[REDACTED] UNCLASSIFIED

Next, a formal rehearsal was completed, with the aircraft flying according to regular flight plan. The received signal level was generally 1000 to 10,000  $\mu\text{v}$  from -60 sec to release, and generally lower and fluctuating from -180 sec to -60 sec. The fluctuations were apparently caused by ground reflections, for at no time did both signals fade simultaneously. In effect, space diversity reception existed, since the antennas were separated vertically, thus providing different path lengths for the interfering ground-reflected waves.

The ground arm-safe switch was closed to arm at approximately H-30 sec, both on the rehearsal flights and on the D-day live run.

## 4.2 Live Runs

### 4.2.1 Cherokee Drop

On Cherokee D-day, a Clarke receiver and EMR discriminator were set up on the ground at Site Fred. A sufficient signal—several microvolts but less than receiver saturation level—was received to drive the discriminator so that a frequency shift at release was observable. It was also noted that this shift in the tone frequency was audible on the receiver speaker. It is interesting to note that a "haywire" setup on Eniwetok Island received a marginal, but still workable, signal level from the airborne transmitter over Bikini. This effect proved that with suitable antennas and preamplifiers it would be possible to receive satisfactory signals at one atoll of Eniwetok Proving Grounds when the transmitter was airborne above the other atoll.

### 4.2.2 Osage Drop

On Osage D-day the ground station was energized at approximately H-1 hr, and the aircraft transmitter was energized at H-45 min. The ground station tuning was trimmed up and, at approximately H-10 min, was given a final trimming. At H-30 sec the arm-safe switch was closed manually and, at release, the circuits operated normally.

## 5 INSTRUMENTATION

### 5.1 Airborne Equipment

Transmitters were installed in the B-36 aircraft in accordance with drawing C-1185 and in the B-52 aircraft per drawing C-1143, both entitled "Redwing Tone - W/D." Change-over to spare transmitters in the aircraft was possible at any time (either on the ground or during flight) by merely changing antenna coaxial feed line from the primary transmitter to the spare and by throwing the power switch to the proper position. Voltage-controlled oscillators were adjusted for equal swings of approximately 400 cycles below and above center frequency when the tone was keyed.

### 5.2 Ground-station Equipment

#### 5.2.1 Receiving Instruments

Two EG&G "blue boxes" were mounted externally on top of the station. These are remote-triggering instruments designed to operate electrical equipment at the instant of high-intensity flash (as used here, they provided a pulse at detonation). The thyatron outputs of these "blue boxes" were brought into two receiving-station oscillograph galvanometers in order to record detonation on the paper record. Two stub antennas were wired into oscillograph galvanometers for the same purpose. Each of these antennas consisted of a 4-ft

[REDACTED] UNCLASSIFIED

UNCLASSIFIED

[REDACTED]

length of-wire tacked to a wooden pole located about 5 ft above the top of the station. In series with each 70-ft coaxial lead-in cable was a diode. Galvanometers with a response of 35 cycles and a sensitivity of 0.005 ma/in. were used, producing a deflection of three-eighths of an inch at burst.

### 5.2.2 Antennas and Mounts

Antennas were assembled and mounted (Fig. 12) with a vertical separation of approximately 15 to 20 ft to provide space diversity reception to override quick fades (vertical separation prevents simultaneous fades). Otherwise, ground reflections and reflections from objects such as roofs (Fig. 9), might have caused quick fades below the receiver threshold. By using RG 8/U cable, the two tubes were joined on each antenna assembly with a tee, and a single RG 8/U cable was run into the control station from each assembly. Moistureproof silicone grease was put into the cable connectors.

### 5.2.3 Preamplifier

Since the antenna lead-ins were sufficiently short (approximately 100 ft), the preamplifiers were mounted indoors in such a position that they could easily be bypassed, or spares substituted, in case of failure. Unshielded multiconductor cables were connected to the rack-mounted preamplifier power supplies. All preamplifier power controls were turned full counterclockwise before applying power.

### 5.2.4 Rack Assembly

Units were installed in accordance with drawing SK(5222)40047, "Rack Equipment Layout, Release Tone." The preformed rack cables and the inter-rack cable were installed, and the external connections were made.

### 5.2.5 Oscillograph

The galvanometers were installed in accordance with SK(5222)40042, "Release Tone System, Block Diagram." Note: Galvanometer No. 1 was located at the rear of the recorder, farthest from the front door of the recorder. The recorder paper speed was set for 6 in./sec, and the galvanometers were aligned.

Before the oscillograph was operated, a new leader was threaded into the take-up magazine (if an old piece of paper had been left in place, it would have taken a permanent set, and the paper probably would not have started). A test record was run to check satisfactory operation.

### 5.2.6 Discriminators

The OUTPUT VOLTAGE control was set to 15 volts, with the vernier control full counterclockwise. ZERO SIG. BAL. was adjusted after a warmup of at least 5 min and with the INPUT control at 0. The BALANCE control was set for equal positive and negative swings of the OUTPUT meter while receiving a keyed release-tone signal. The PUSH FOR AMP. BAL. was adjusted for 0 on the OUTPUT meter.

### 5.2.7 Receivers

A 100-ohm, 1-watt resistor was connected across rear terminals 5 and 6.

UNCLASSIFIED

[REDACTED]

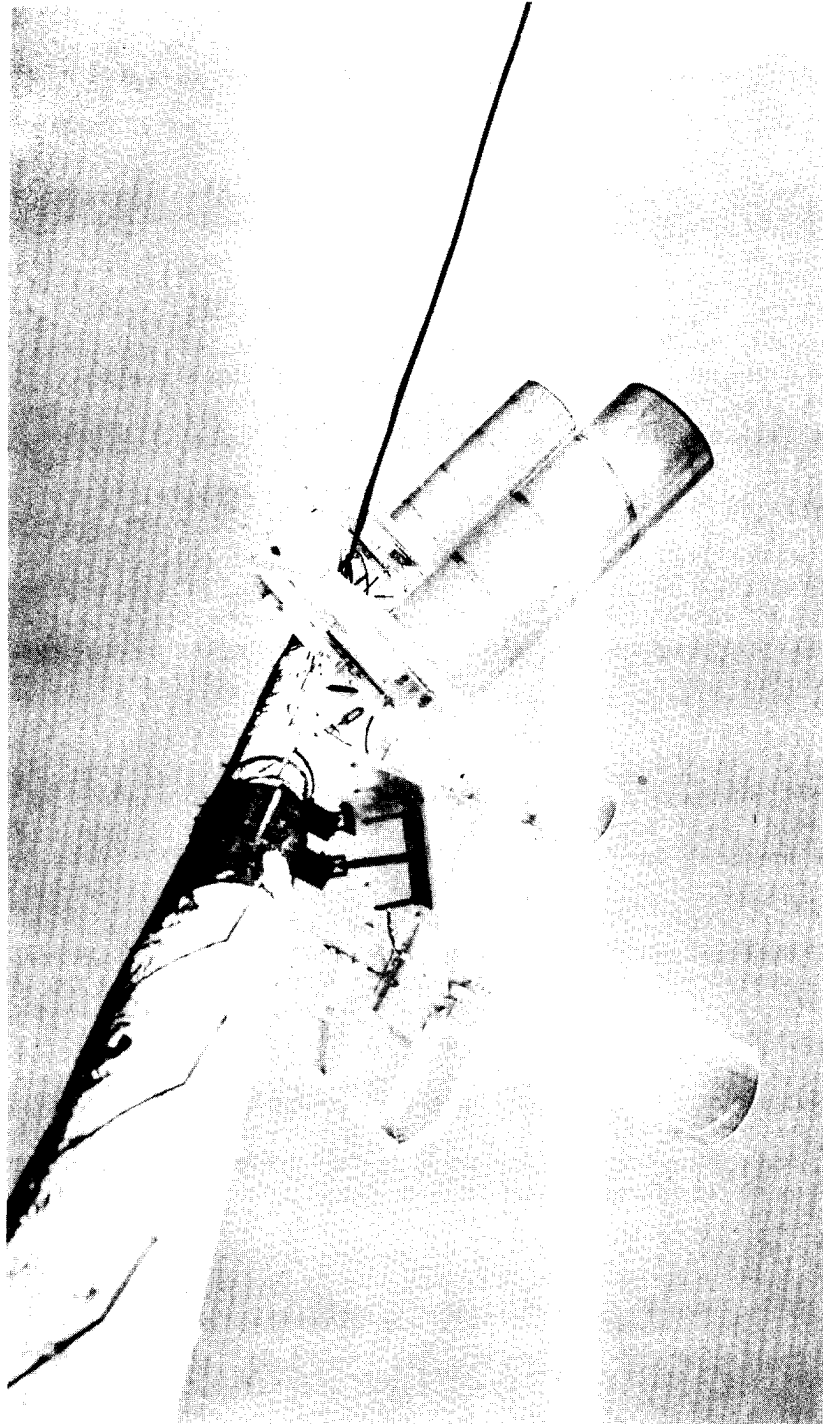

Fig. 12 -- Antennas and M...s

**5.2.8 Oscillograph Attenuator**

Front-panel potentiometers were set for 1/4- to 3/8-in. deflections of the galvanometers.

**5.2.9 Oscilloscopes**

Oscilloscopes were adjusted to show 3 cycles of receiver output on the prerelease signal and 4 cycles after release.

**5.2.10 Control Panel**

The arm-safe switch was closed, and the 1000-cycle tone level was adjusted as desired on the speakers while receiving prerelease signal (if recorder operation is not desired, recorder power should be turned off temporarily). The arm-safe switch was opened, and the recorder power was switched on.

**6 RESULTS**

**6.1 Conclusions and Recommendations**

The equipment described in this report performed satisfactorily in all requirements. The following recommendations and modifications of procedure have resulted from this operation:

One man employed full time and one man employed part time (for a total of approximately 2 or 3 wks) is sufficient manpower to set up and operate the stations. Except for the installation of the antennas, the entire ground station can be set up by one man. For the tests reported here, local contractors were used to install the antennas, which, for one drop, were pole mounted; for the other drop, tower mounted, with the mounts welded to the tower legs.

In future operations it would be desirable to have all installation and checkout of airborne equipment performed at KAFB in Albuquerque instead of at the test site. In the tests reported here, the airplane cabling was done at Albuquerque (KAFB), and the airborne units were installed and checked out at the test site.

To allow for test runs, the entire release tone system should be operable by at least D-10 days. Representatives of EG&G had a timing run each morning for several days before the drop events, with the release tone system operated to start the EG&G sequence timer. The same practice is recommended for future operations.

**REFERENCES**

1. R. Ruddlesden, E. Forster, and Z. Jelonek, Carrier-Frequency-Shift Telegraphy, Journal AIEE, Vol. 94, Part IIIA, No. 12, pp. 379-389 (1947).
2. H. O. Peterson et al, Observation and Comparison on Radio Telegraph Signaling by Frequency Shift and On-Off Keying, RCA Review, Vol. 7, pp. 11-13 (March 1946).

UNCLASSIFIED

APPENDIX A

A.1 AIRBORNE EQUIPMENT (Fig. 4)

A.1.1 Transmitter Power Amplifier: Rheem RF Amplifier REL-09

Frequency range: 215-235 mc  
Power output: 12 watts minimum  
Impedance: 52 ohms input and output  
Input drive: 1.4 watts for rated output  
Power input: 90 milliamperes at 250 volts direct current plus 0.41 amp at 12.6 volts alternating current or direct current or 0.82 amp at 6.3 volts alternating current or direct current

A.1.2 Transmitter: Bendix-Pacific TXV-13 Crystal-controlled, PM

Frequency range: 215-235 mc  
Power output: 2 watts  
Load impedance: 50 ohms  
Modulation input impedance: 270,000 ohms, shunted by 200,000 ohms in series with 200  $\mu\text{mf}$   
Deviation sensitivity: 12 kc/kc/volt  $\pm 15\%$  (for 0.4 - 4.0 kc)  
50 kc/volt  $\pm 15\%$  (for 4.0 - 85.0 kc)  
Frequency stability: Within 0.01%,  $-40^{\circ}$  to  $185^{\circ}\text{F}$   
Within 0.02% for  $\pm 10\%$  Ep and  $\pm 13\%$  - 6% filament change, taken simultaneously  
Vibration: Less than 1% peak carrier deviation for 10g up to 1000 cycles, in any plane  
Power input: 85 milliamperes at 180 volts direct current  
1.2 amp at 6.0 volts alternating current or direct current

A.1.3 Voltage-controlled Oscillator: Audio Products Corporation

Frequency: 5400 cycles  
Deviation: 15% ( $\pm 7.5$ )  
Input for full deviation: 0 to +5 volts direct current; or 5 volts p-p (alternating current) superimposed on +2.5 volts direct current  
Output: At least 2.0 volts rms  
Output impedance: Approximately 300 ohms  
Linearity: Not more than 3% deviation from straight line  
Frequency stability: Within 2% for filament change of  $\pm 10\%$  or a plate voltage change of  $\pm 3\%$   
Power input: 7 milliamperes at 150 volts direct current; 28-volt filaments

A.1.4 Power Supply: Gothard Dynamotor GY-25

Output: 0.5 amp at 250 volts direct current  
Input: 28 volts direct current

UNCLASSIFIED



A.1.5 Shift Circuit:

This consists of 4 normally closed switching components in series. These are (1) a spring-loaded, momentary-contact test switch mounted under a red safety cover; (2, 3) two microswitches which operate on release; and (4) a cable pullout connector in the unit to act as backup in the event of microswitch failure.

A.2 GROUND-STATION EQUIPMENT (Figs. 10 and 11)

A.2.1 Antenna: Two 4-turn helices mounted on folded ground plane

Beam width: Approximately 45 degrees vertical and approximately 100 degrees horizontal

Mounts: Vertically adjustable from approximately 20 to 40 degrees above horizon; horizontal, approximately ±30 degrees

Gain: Approximately 7 db

Bandwidth: Approximately 160 to 260 mc

A.2.2 Preamplifier: Ascop (Applied Science Corp. of Princeton, N. J.)  
APA-2 Radio Frequency Preamplifier

Bandwidth: 215-235 mc

Gain: 15 db minimum

Noise figure: 2.5 db

Impedance: 52 ohms input and output

Power input: 115 volts 60 cycles

Enclosure: Weather resistant (NOTE: Control panel is indoor-mounted on 19 x 3-1/2-in. panel)

A.2.3 Multicoupler: Ascop (Applied Science Corp. of Princeton, N. J.)  
AMC-2 Multicoupler

Bandwidth: 215-235 mc

Gain: 9 db

Noise figure: 9.5 db

Impedance: 52 ohms input and output

Number of outputs: 4

Isolation between outputs: 34 db minimum

Power input: 115 volts 50 cycles

Panel size: 19 x 7 in.

A.2.4 Receiver: Nems-Clarke Type 167-J-1 FM/AM Receiver

Tuning range: 55-260 mc

Noise figure: 11 db below 245 mc

Sensitivity: 8 μv for 22-1/2 db signal-to-noise ratio

IF bandwidth: 300 kc

Discriminator linearity: ±150 kc

Output: 0.08 volt/kc (FM)

Limiting: Output constant within 2 db for inputs above 4 μv (FM)

Signal level indication: 0-10 ma direct current, inversely related to signal strength

Power input: 117 volts 60 cycles, 65 watts

Panel size: 19 x 8-3/4 in.

UNCLASSIFIED



~~SECRET~~

UNCLASSIFIED

A.2.5 Discriminator: EMR (Electro-Mechanical Research, Inc.)  
Model 67 D Subcarrier Discriminator

Frequency: 5400 cycles (available from 400 cycles to 70 kc)  
Deviation:  $\pm 7.5\%$  and  $\pm 15\%$ ; approximately  $\pm 10\%$  used on this system  
Input impedance: 0.5 megohm shunted by approximately 20  $\mu\text{mf}$   
Sensitivity: 10 mv minimum potentiometer input  
Dynamic range: 30 db for any input level setting  
Output: Single ended, referred to ground; variable from  $\pm 6.6$  volts to  $\pm 90$  volts  
with maximum of  $\pm 25$  ma  
Output impedance: Less than 10 ohms  
Output stability:  $\pm 0.5\%$  of full bandwidth in a 15-hr period after 15-min warmup  
Panel size: 19 x 5-1/4 in.  
Power input: 105-125 volts 60 cycles, 200 watts; no external regulation required

A.2.6 Control Panel: Sandia Corporation manufacture in accordance with drawing  
SK(5222)55731

This unit contains the biased polar relays. These are energized by the discriminator outputs which, in turn, close the sequence-timer start circuit. A seal-in relay is included to ensure a continuous closure to the timer start, even though other components might fail or operate intermittently.

Other relays are included for indication only. These relays mute the 1000-cycle speaker signal on release and also change lamp indication from green to red.

Two transfer switches are provided, one for each tone. These allow for switching to the standby equipments.

An arm-safe switch is on the front panel to provide single point deactivation of the entire system until the desired moment. A spring-loaded, momentary contact emergency start button, under a protective cover, is also on the front panel. Panel size: 19 x 12-1/4 in.

A.2.7 Oscilloscope: DuMont Type 304-AR Cathode Ray Oscilloscope (Rack-mounted)

Vertical sensitivity: 0.025 peak-peak volt/in. (amplifier)  
32-39 peak-peak volt/in. (direct)  
Frequency response: Down not more than 50% at 300 kc  
Rise time: 2  $\mu\text{sec}$  or less  
Input impedance: 2 meg, 50  $\mu\text{mf}$  (amplifier)  
1.5 meg, 20  $\mu\text{mf}$  (direct)  
Internal sweep: 2-30,000 cycles  
Rack size: 19 x 8-3/4 in.  
Power input: 115 or 230 volts 50-400 cycles, 110 watts

A.2.8 Paper Recorder: William Miller Model J Multi-Channel Oscillograph (Plus  
Model JP2 Power Supply)

Number of channels: 30 (16 used in this system)  
Paper speeds, in./sec: 3/8, 3/4, 1-1/2, 3 (low speed)  
6, 12, 24, 48 (high speed)

UNCLASSIFIED



Timing-line intervals (after modification for use with paper recorder time mark generator): 1/10 sec, 1 sec (low speed)  
1/100, 1/10, 1 sec (high speed)

Paper capacity: 12 in. x 200 ft

Recommended paper: Eastman Linagraph 809 (low speed)  
Eastman Linagraph 1057 (high speed)

<u>High-sensitivity galvanometers:</u>	<u>Nat freq</u>	<u>Ma/in.</u>	<u>Ext damping resistance</u>	<u>Galvanometer resistance</u>
	35	0.005	1000	45
	75	0.02	500	45
	100	0.035	350	45
	120	0.05	250	45
	140	0.065	200	45
	180	0.17	None	45
	230	0.17	100	45
	340	0.6	130	45
	460	1.0	35	45
	1000	6.0	None	45
	1900	18.0	None	45
	3200	50.0	None	45

Recorder size: 16-1/2 in. wide x 12-1/2 in. high x 15-3/4 in. long

Power pack size: Approximately 8 x 10 x 14 in.

Power input: 110 volts 60 cycles

Timing input: Paper recorder time mark generator (Tech Memo 134-53-52), driven by 1000-cycle source

A.2.9 Paper Recorder Time Mark Generator: Sandia Corporation manufacture per drawing SK(5226)24614

Input: 1000 cycles, 0.5 to 2 volts

Output pulses rate: 1000, 100, 10, 1 per sec

Output pulse shape: Differentiated square waves, i.e., alternately positive and negative pulses

Output pulse amplitude: Approximately 2 volts

Rack size: 19 x 8-3/4 in.

Power input: 115 volts 60 cycles

A.2.10 Generator, 1000-cycle: Sandia Corporation manufacture

Frequency standard: American Time Products Type 2001-2 Frequency Calibrator, 1000 cycles

Output: Approximately 1 watt

Output impedance: 500 ohms

Rack size: 19 x 5-1/4 in.

A.2.11 Oscillograph Attenuator: Sandia Corporation manufacture; contains galvanometer damping resistors and attenuator potentiometers

Rack size: 19 x 3-1/2 in.

UNCLASSIFIED



[REDACTED]

A.2.12 Test Transmitter: Sandia Corporation assembly consisting of the following:

Transmitters (2): Bendix-Pacific TXV-13 Crystal-controlled, PM  
Transmitter frequencies: 117.5 and 220.5 mc  
Power amplifier: None  
Voltage-controlled oscillator: Audio Products, 5400 cycles  
Rack size: 19 x 8-3/4 in.  
Power input: 115 volts 60 cycles  
Keying means: Test switch and motor-drive cam switch

A.2.13 Cables: Prefabricated cables are employed so that field installation consists of setting up the units and plugging in the cables.

UNCLASSIFIED

~~CONFIDENTIAL~~

APPENDIX B

B.1 ITEMS WHICH COULD FAIL WITHOUT AFFECTING PROPER OPERATION OF THE  
TIMER-START RELAY:

- Oscilloscopes (2)
- Oscillograph (1)
- Oscillograph attenuator panel (1)
- 1000-cycle generators (2)
- Test transmitter (1)
- Time mark generator (1)

Also, since two independent channels operate in parallel, either channel plus all spares could fail without affecting operation. Included are:

- Airborne PA (3)
- Airborne Xmtr (3)
- Airborne VCO (3)
- Preamplifier (1)
- Multicoupler (1)
- Receivers (3)
- Discriminators (3)
- Approximately 90% of 1 control panel

B.2 ITEMS ESSENTIAL TO PROPER OPERATION:

- Airborne PA (1)
- Airborne Xmtr (1)
- Airborne VCO (1)
- Preamplifier (1) (Could be bypassed, time permitting)
- Multicoupler (1) (Could be bypassed, time permitting)
- Receiver (1)
- Discriminator (1)
- Polar relay (1) (One component on the control panel)

34 UNCLASSIFIED

~~CONFIDENTIAL~~

~~CONFIDENTIAL~~

CONFIDENTIAL

CONFIDENTIAL

## DISTRIBUTION

### *Military Distribution Category 4*

#### ARMY ACTIVITIES

Asst. Dep. Chief of Staff for Military Operations, D/A, Washington 25, D. C. ATTN: Asst. Executive (R&SW)	1-2
Chief of Research and Development, D/A, Washington 25, D. C. ATTN: Atomic Division	3
Chief Signal Officer, D/A, P&O Div., Washington 25, D. C. ATTN: SIGRD-8	4
Commanding General, Headquarter, United States Continental Army Command, Fort Monroe, Va.	5
Director, Special Weapons Development Office, Headquarters, CONARC, Ft. Bliss, Tex. ATTN: Capt. T. E. Skinner	6

#### NAVY ACTIVITIES

Chief of Naval Operations, D/N, Washington 25, D. C. ATTN: OP-36	7
Chief of Naval Research, D/N, Washington 25, D. C. ATTN: Code 811	8
Director, U. S. Naval Research Laboratory, Washington 25, D. C. ATTN: Mrs. Katherine H. Cass	9

#### AIR FORCE ACTIVITIES

Asst. for Atomic Energy, Headquarters, USAF, Washington 25, D. C. ATTN: DCS/O	10
Director of Research and Development Div., DCS/O, Headquarters, USAF, Washington 25, D. C. ATTN: Combat Components Div.	11
Commandant, Air Force School of Aviation Medicine, Randolph AFB, Tex.	12-13
Commander, Air Force Special Weapons Center, Kirtland, AFB, N. Mex. ATTN: Library	14
Commander, Western Development Div. (ARDC), PO Box 262, Inglewood, Calif. ATTN: WDSIT, Mr. R. G. Weitz	15

#### OTHER DEPARTMENT OF DEFENSE ACTIVITIES

Commander, Field Command, Armed Forces Special Weapons Project, PO Box 5100, Albuquerque, N. Mex.	16
Commander, Field Command, Armed Forces Special Weapons Project, PO Box 5100, Albuquerque, N. Mex. ATTN: Tech. Training Group	17
Commander, Field Command, Armed Forces Special Weapons Project, PO Box 5100, Albuquerque, N. Mex. ATTN: Deputy Chief of Staff, Weapons Effects Test	18-19
Chief, Armed Forces Special Weapons Project, Washington 25, D. C. ATTN: Document Library Branch	20-30

#### ATOMIC ENERGY COMMISSION ACTIVITIES

U. S. Atomic Energy Commission, Classified Technical Library, 1901 Constitution Ave., Washington 25, D. C. ATTN: Mrs. J. M. O'Leary (for DMA)	31-33
Los Alamos Scientific Laboratory, Report Library, PO Box 1663, Los Alamos, N. Mex. ATTN: Helen Redman	34-38
Sandia Corporation, Classified Document Division, Sandia Base, Albuquerque, N. Mex. ATTN: Martin Lucero	39-53
University of California Radiation Laboratory, PO Box 808, Livermore, Calif. ATTN: Margaret Edlund	54-56
Weapon Data Section, Technical Information Service Extension, Oak Ridge, Tenn.	57
Technical Information Service Extension, Oak Ridge, Tenn. (surplus)	58-85

~~CONFIDENTIAL~~

CONFIDENTIAL