

REPORT DOCUMENTATION PAGE

Form Approved
OMB No. 0704-0188

Public reporting burden for this collection of information is estimated to average 1 hour per response, including the time for reviewing instructions, searching existing data sources, gathering and maintaining the data needed, and completing and reviewing the collection of information. Send comments regarding this burden estimate or any other aspect of this collection of information, including suggestions for reducing this burden, to Washington Headquarters Services, Directorate for Information Operations and Reports, 1215 Jefferson Davis Highway, Suite 1204, Arlington, VA 22202-4302, and to the Office of Management and Budget, Paperwork Reduction Project (0704-0188), Washington, DC 20503.

1. AGENCY USE ONLY (Leave blank)	2. REPORT DATE 15 June 1996	3. REPORT TYPE AND DATES COVERED Summary 01 Jun 95 - 31 May 96
----------------------------------	--------------------------------	---

4. TITLE AND SUBTITLE GEOMETRICAL ASPECTS OF SCATTERING AND PHYSICAL EFFECTS OF SOUND	5. FUNDING NUMBERS PE 61153N G N0001492J1600
---	--

6. AUTHOR(S) Philip L. Marston	
---------------------------------------	--

7. PERFORMING ORGANIZATION NAME(S) AND ADDRESS(ES) DEPARTMENT OF PHYSICS WASHINGTON STATE UNIVERSITY PULLMAN WA 99164-2814	8. PERFORMING ORGANIZATION REPORT NUMBER N00014-92-J-1600-AR3
---	--

9. SPONSORING / MONITORING AGENCY NAME(S) AND ADDRESS(ES) OFFICE OF NAVAL RESEARCH ONR 331 800 NORTH QUINCY STREET ARLINGTON VA 22217-5660	10. SPONSORING / MONITORING AGENCY REPORT NUMBER
--	--

11. SUPPLEMENTARY NOTES
Research proposed in "Geometrical Aspects of Scattering and Physical Effects of Sound," and in AASERT proposal, P. L. Marston, principal investigator. Telephone (509-335-5343).

12a. DISTRIBUTION / AVAILABILITY STATEMENT Approved for public release: Distribution unlimited	12b. DISTRIBUTION CODE 19960708 028
--	---

13. ABSTRACT (Maximum 200 words)
Research is reported in the following areas: [1] Transient and high-frequency enhancements of the scattering of sound by elastic objects in water are measured and analyzed. (The impulse response of a thick cylindrical shell in water was measured as a function of aspect angle. The measurements show the frequency locus of a backscattering enhancement extending to near end-on incidence in agreement with predictions for an antisymmetric leaky Lamb wave. Other enhancements and supporting theoretical developments are noted.) [2] New measurements and theoretical work on the interaction of sound with sound mediated by an aqueous suspension display coherent scattering effects for a range of conditions. [3] The coupling of an oscillating magnetic field to the quadrupole quasi-flexural mode of a shell in air is investigated. (An acoustic signature produced by shell vibrations in response to an oscillating Maxwell stress is easily detected even without the static bias magnetic field normally used in an EMAT.) [4] An oscillating electric field is used to excite the monopole mode of bubbles in an insulating liquid. (As with item (3), the method may be useful for measuring mode frequency and damping where exact solutions are not known.)

14. SUBJECT TERMS Acoustical Scattering, Ray Methods, Elastic Shells, Bubbles, Plates, Particle Suspensions, Nonlinear Acoustics, Rayleigh Waves	15. NUMBER OF PAGES 16
	16. PRICE CODE

17. SECURITY CLASSIFICATION OF REPORT UNCLASSIFIED	18. SECURITY CLASSIFICATION OF THIS PAGE UNCLASSIFIED	19. SECURITY CLASSIFICATION OF ABSTRACT UNCLASSIFIED	20. LIMITATION OF ABSTRACT
---	--	---	----------------------------

GEOMETRICAL ASPECTS OF SCATTERING AND PHYSICAL EFFECTS OF SOUND

Philip L. Marston
Department of Physics
Washington State University
Pullman, Washington 99164-2814

June 1996

Annual Summary Report for Grant N00014-92-J-1600

1 June 1995 - 31 May 1996

Approved for public release: Distribution Unlimited.

Prepared for: **Office of Naval Research**
ONR 331
800 North Quincy Street
Arlington, VA 22217-5660

TABLE OF CONTENTS

I.	Transient and High-Frequency Enhancements in Scattering from Elastic Objects: Project Description, Approaches, and Accomplishments	3
II.	Interaction of Sound with Sound Mediated by a Suspension of Particles: Project Description, Approaches, and Accomplishments	4
III.	Electromagnetic Excitation of Elastic Modes of a Shell: Project Description, Approaches, and Accomplishments	5
IV.	Monopole Mode of a Bubble Excited by Oscillating Electric Fields: Project Description, Approaches, and Accomplishments	6
V.	Publications, Patents, Presentations, and Honors Report	8
VI.	Appendix A: Supplement to Section I	10
VII.	Appendix B: Research Results from Other Grants or Sponsors	13

The project description, approaches, and summary of accomplishments are grouped according to Projects I, II, III, and IV.

I. A. Project Description: Transient and High-Frequency Enhancements in Scattering from Elastic Objects -- The objective is to identify physical processes that are likely to be important for the classification of scatterers in water based on high frequency scattering signatures. When possible, quantitative ray approximations are formulated to predict scattering amplitudes and experiments are used to test the approximations. The research will also give insight into scattering processes for scatterers at interfaces.

B. Approaches Taken: Leaky waves guided along the surface of the scatterer are investigated and modeled by extensions of Marston's formulation [JASA 97, 34-41 (1995)]. One specific process being studied involves the excitation of guided waves that reflect off of the end of tilted cylinders to produce large backscattering signatures for certain ranges of aspect angles. Impulse responses are measured as a function of aspect angle using an improved version of the PVDF sheet source originally described in Kaduchak, Kwiatkowski, and Marston [JASA 97, 2699-2708 (1995) and 1995 Annual Report pp. 4-15]. These are compared with recent approximate partial wave series (PWS) calculations for finite cylinders by G. Kaduchak (at ARL-UT Austin). Tone burst measurements are also taken, especially in the case of Karen Gipson's study of retroreflective backscattering due to Rayleigh waves on elastic solids with square corners.

Related investigations include scattering processes for elastic and fluid objects of variable thickness, including a novel exact PWS formulation [JASA (abstract) 98, 2928 (1995)] and ray approximations which account for focusing of internal reverberations.

C. Accomplishments:

- Measurements were taken by Scot Morse of the impulse response of an empty thick cylindrical shell in water as a function of aspect angle [JASA (abstract) 99, 2544 (1996)]. The measurements clearly show the frequency locus of a backscattering enhancement as a function of aspect angle extending to near end-on incidence. Appendix A of this report gives a summary which identifies a generalization of the lowest antisymmetric leaky Lamb wave as the corresponding contributor. The measurements are significant since related enhancements previously reported for aspect angles much closer to broadside have been shown to significantly enhance target visibility in a high-frequency imaging sonar [Kaduchak et al., JASA (accepted for publication)]. Morse has also experimentally

detected other high frequency backscattering enhancements associated with leaky wave propagation along the tilted cylinder which give end reflections.

- A more general spatial convolution formulation of the quantitative ray theory of such leaky wave scattering processes was developed by embedding Marston's previous two-dimensional formulation into three dimensions. The formulation is based on a Laurent expansion of leaky wave contributions to the reflection coefficient. (The formulation does not make use of thin shell assumptions for the local leaky wave mechanics.) The new formulation uses a two-dimensional surface convolution and was first tested by recovering several previously known special cases for leaky waves. For circular cylinders, these include scattering amplitudes, elliptical Fresnel coupling patches [Marston, JASA 96, 1893-1898 (1994)], and the ray coupling conditions as a function of tilt. The new formulation explains how tilted cylinders with abrupt ends can have leaky wave backscattering enhancements similar in magnitude to signals associated with broadside reflections. The relevant ray paths do not involve repeated circumnavigations, and the enhancements are not associated with phenomena usually described as resonances.
- In related work, Karen Gipson has identified ways of improving the analysis of the retroreflective mechanism for enhanced backscattering due to leaky waves on a solid rectangular block with corners (1995 Annual Report, p. 16). Scot Morse analyzed the stability of rays reverberating between nonconcentric surfaces within a thick shell and predicted that a far-field focusing in the surrounding water can be produced which is periodic in the number of internal reflections. An approximate description of such periodic focal enhancements was developed using the Pearcey integral, and the existence of periodic foci was confirmed by measuring the backscattering of ultrasonic tone bursts by large glass lenses in water [JASA (abstract) 99, 2544 (1996)].

II. A. Project Description: Interaction of Sound with Sound Mediated by a Suspension of Particles -- The objective of this project is to understand the large effects that suspended particles can have on the interaction of sound with sound in water. Since large acoustic signatures are observed even with very small volume fractions ϕ of suspended particles, the interaction may have practical applications for the measurement of ϕ or the particle compressibility. More generally, the interaction process is of a class that has previously been ignored in nonlinear acoustics.

B. Approaches Taken: Two acoustic signatures of the suspension are investigated: (i) the Bragg scattering from particle layers induced by the radiation pressure of a standing wave resonator due to the migration of the particle positions; (ii) the shift in the resonance

frequency of an ultrasonic standing wave as a result of the particle migration. The acoustic signatures in (i) are predicted to be much larger than for incoherent scattering from suspended particles since when particles migrate to pressure nodes (or antinodes) of the standing pump wave and the Bragg condition for the probe wave is met, all of the particles scatter with the same phase modulo (2π) [Simpson and Marston, JASA 98, 1731-1741 (1995) and submitted to *Physical Acoustics*]. Our current method of measuring the Bragg scattering uses a probe wave that is collinear with the pump wave.

C. Accomplishments:

- Chris Kwiatkowski has measured and modeled the amplitude of the collinear Bragg signal as a function of parameters in the probe signal including frequency, duration, and bounce number of the reverberating probe signal. An extended range of suspension compositions and volume fractions have been tested including: polystyrene particles, glass particles, and bubbles [JASA (abstract) 99, 2560 (1996)]. For small volume fractions ϕ , the measured reflectivity at the Bragg condition increases linearly with ϕ and probe duration and approximately linearly with bounce number, in general agreement with theory based on a Born approximation. A more general theory has been formulated based on transfer matrices. A skewed frequency response has been measured at large volume fractions of particles ($\phi \approx 0.01$).
- Kwiatkowski has also measured the downward shift in the pump wave resonance frequency resulting from banding of particles in water in an ultrasonic standing wave resonator. The resonance frequency is originally measured with a spatially uniform particle distribution at low standing wave amplitudes. The frequency shift was modeled using the Boltzmann-Ehrenfest principle of adiabatic invariance. The effect of the position of a single particle on the resonant frequency is described by Putterman et al. [JASA 85, 68-71 (1989)] for a simpler problem. The analysis was modified to the present situation of a suspension of compressible particles. The typical frequency shift for a dilute suspension with $\phi = 0.001$ is 130 Hz for a 800 kHz resonance. The shift is typically within 20% of predictions.

III. A. Project Description: Electromagnetic Excitation of Elastic Modes of a Shell -- The objective is to determine whether oscillating magnetic fields can be used to excite specific modes of electrically conducting shells so as to produce easily detectable acoustic radiation in the surrounding fluid. This type of transduction has potential application to mode spectroscopy of fluid loaded shells where exact mode solutions are not known and to hybrid electromagnetic - acoustic object detection.

B. Approach: The excitation of modes with the Lorentz force on eddy currents in the presence of a large static bias magnetic field is first used to measure the frequency of specific modes of interest of a shell in air. The acoustic radiation is detected by a microphone. (This linear coupling is analogous to the one used by Matula and Marston to excite flexural waves on a plate [JASA 97, 1389-1398 (1995)]). Evaluation of the Maxwell electromagnetic stress tensor shows that even in the absence of a static bias field, an oscillating magnetic field B produces oscillating stresses. Since the stress is proportional to B^2 , the stress oscillates at twice the frequency of the oscillating field.

C. Accomplishments:

- B. T. Hefner confirmed both the direct (Lorentz-force) coupling at the frequency f of the oscillating field and also the second-order (Maxwell) coupling at frequency $2f$ [JASA (abstract) 99, 2594 (1996)]. The lowest frequency mode of a spherical shell was excited, which was a quadrupole quasiflexural mode near 64 kHz. In the absence of a static bias field, an f near 32 kHz was needed to observe the desired Maxwell coupling.

IV. A. Project Description: Monopole Mode of a Bubble Excited by Oscillating Electric Fields -- While the monopole response of bubbles to incident acoustic fields is relevant to a number of naval technologies, it can be difficult to directly measure the resonance response and damping of single bubbles. The objective of this project is to determine whether the monopole mode of bubbles in insulating liquids may be directly excited with oscillating electric fields. This would provide a new method of exploring bubble response and acoustic radiation for situations where the mode damping and frequency can not be directly calculated.

B. Approach: A dielectrophoretic levitator is used to trap bubbles in a low viscosity electrically insulating oil. An oscillating tone burst voltage is superposed on the static levitation voltage and any resulting acoustic radiation is detected with a hydrophone in the oil bath. Analysis of the general form of Maxwell stresses on the bubble indicates that the bubble should primarily oscillate at the same frequency as the applied tone burst.

C. Accomplishments:

- Experiments carried out with Dr. D. B. Thiessen confirmed the existence of the desired coupling [JASA (abstract) 99, 2560 (1996)]. The measurements were taken for bubbles having radii between 0.5 and 2 mm giving monopole frequencies between 7 kHz and 2 kHz, which are near the predicted values. The response was maximized when the tone

burst frequency was at resonance. The observed ring-down of the signature after the excitation suggests that the method could be used to measure damping in a sufficiently larger tank of liquid where reverberations could be neglected.

- The proper detailed form of stress tensor for determining the strength of the coupling at a dielectric interface due to an oscillating field is a controversial subject. This is because in some types of experiments the Helmholtz contribution appears to be canceled by the electrostrictive response of the liquid. The radial projection of the oscillating stress and the resulting bubble responses were calculated for certain cases. Assuming the aforementioned cancellation, the projection gives the same value as the electric field contribution to the pressure calculated by Marston and Apfel by another method [Physics Letters 60A, 225-226 (1977)]. While our measurements of the bubble response are presently not able to discriminate between different models of the coupling, that should not prevent the method from being used to measure bubble mode frequency and decay.

OFFICE OF NAVAL RESEARCH
PUBLICATIONS/PATENTS/PRESENTATIONS/HONORS REPORT
for
01 June 95 through 31 May 96

8

Contract/Grant Number: N00014-92-J-1600

Contract/Grant Title: Geometrical Aspects of Scattering and Physical Effects of Sound

Principal Investigator: Philip L. Marston

Mailing Address with ZIP+4 if applicable: Physics Department
Washington State University
Pullman, WA 99164-2814

Phone Number: 509-335-5343

Facsimile Number: 509-335-7816

E-mail Address: marston@wsu.edu

- | | |
|--|----------|
| a. Number of papers submitted to refereed journals but not yet published: | <u>1</u> |
| b. Number of papers published in refereed journals (ATTACH LIST): | <u>3</u> |
| c. Number of books or chapters submitted but not yet published: | <u>1</u> |
| d. Number of books or chapters published (ATTACH LIST): | <u>0</u> |
| e. Number of printed technical reports & non-refereed papers (ATTACH LIST): | <u>1</u> |
| f. Number of patents filed: | <u>0</u> |
| g. Number of patents granted (ATTACH LIST): | <u>0</u> |
| h. Number of invited presentations at workshops or professional society meetings: | <u>3</u> |
| i. Number of contributed presentations at workshops or professional society meetings: | <u>8</u> |
| j. Honors/awards/prizes for contract/grant employees, such as scientific society and faculty awards/offices (ATTACH LIST): | <u>2</u> |
| k. Number of graduate students supported at least 25% this year this contract/grant: | <u>4</u> |
| l. Number of post docs supported at least 25% this year this contract/grant: | <u>1</u> |

How many of each are females or minorities? These six numbers are for ONR's EEO/Minority Reports. Minorities include Blacks, Aleuts, Amindians, etc., and those of Hispanic or Asian extraction/nationality. The Asians are singled out to facilitate meeting reporting semantics re "underrepresented".

Graduate student FEMALE:	<u>1</u>	Post doc FEMALE:	_____
Graduate student MINORITY:	_____	Post doc MINORITY:	_____
Graduate student ASIAN E/N:	_____	Post doc ASIAN:	_____

1996 P³H Report Supplement for Grant N00014-92-J-1600

b. Papers Published in Refereed Journals:

1. H. J. Simpson and P. L. Marston, "Ultrasonic four-wave mixing mediated by an aqueous suspension of microspheres: theoretical steady-state properties," *J. Acoust. Soc. Am.* **98**, 1731-1741 (1995).
2. P. L. Marston, "Variable phase coupling coefficient for leaky waves on spheres and cylinders from resonance scattering theory," *Wave Motion* **22**, 65-74 (1995).
3. G. Kaduchak and P. L. Marston, "Traveling-wave decomposition of surface displacements associated with scattering by a cylindrical shell: Numerical evaluation displaying guided forward and backward wave properties," *J. Acoust. Soc. Am.* **98**, 3501-3507 (1995).

c. Printed Technical Reports & Non-refereed Papers:

1. P. L. Marston, "Scattering and radiation of high frequency sound in water by elastic objects, particle suspensions, and curved surfaces," Annual Summary Report for ONR Grant N00014-92-J-1600 (issued June, 1995).

j. Honors/awards/prizes for contract/grant employees:

1. S. F. Morse, Third-place award from the Acoustical Society of America in the 1995/96 Annual "Best Student papers in Structural Acoustics and Vibration," competition based on his paper and presentation: "Backscattering due to ray reverberations between nonconcentric surfaces of a thick shell: ray stability, transitions in wavefront shapes, and observed scattering enhancements due to focusing."
2. P. L. Marston, President of the Inland Northwest Acoustical Society of America Chapter (1995 - Spring 1996).

k and l. Total Number of Graduate Students and Post Docs Supported at Least 25% This Year on This Grant.

Graduate Students: 4

Karen Gipson
Chris Kwiatkowski
Scot Morse
Brian T. Hefner

Post Docs: 1

David Thiessen

Appendix A: Elastic Contribution to the High-Frequency Backscattering by a Thick Cylindrical Shell Extending to Near End-On Incidence

Figure 1 shows the scattering geometry under consideration where from symmetry a single aspect angle γ characterizes the target orientation; $\gamma = 0^\circ$ corresponds to broadside illumination. A plausible leaky wave ray contribution is also shown where for strong excitation of the leaky wave $\sin \gamma \approx c/c_l$, where c_l is the leaky wave phase velocity at a specified frequency and c is the speed of sound in water. The existence of such enhancements for large γ (near 90°) may be important to enhancing the target visibility of cylinders when viewed from a significant distance in shallow water. The ray mechanism shown should be present at frequencies slightly above the coincidence frequency from the generalization of the supersonic branch of the lowest antisymmetric a_0^+ leaky Lamb wave.

The experimental set up to test for such contributions is shown in Fig. 2 where the PVDF sheet produces a pressure impulse [Kaduchak, Kwiatkowski, and Marston, JASA 97, 2699-2708 (1995) and 1995 Annual Report]. The aspect angle is computer controlled by a stepper motor. Figure 3(a) shows the spectral magnitude of the measured impulse response as a function of frequency and aspect angle. The initial specular reflection from the end of the cylinder closest to the source is time gated out of each record prior to evaluation of the spectrum. The wave-number radius product ka has a value of 10 at a frequency of 112 kHz in this experiment. Figure 3(a) shows a clear ridge of enhanced backscattering extending from the right near γ of 40° to γ near 90° . Figure 3(b) shows that this ridge is the result of the a_0^+ leaky Lamb wave contribution with the ray diagram shown in Fig. 1. The curve shown in Fig. 3(a) is $\gamma = \sin^{-1}(c/c_l)$ where c_l is the calculated for the a_0^+ wave on a water-loaded plate having the same thickness as the shell.

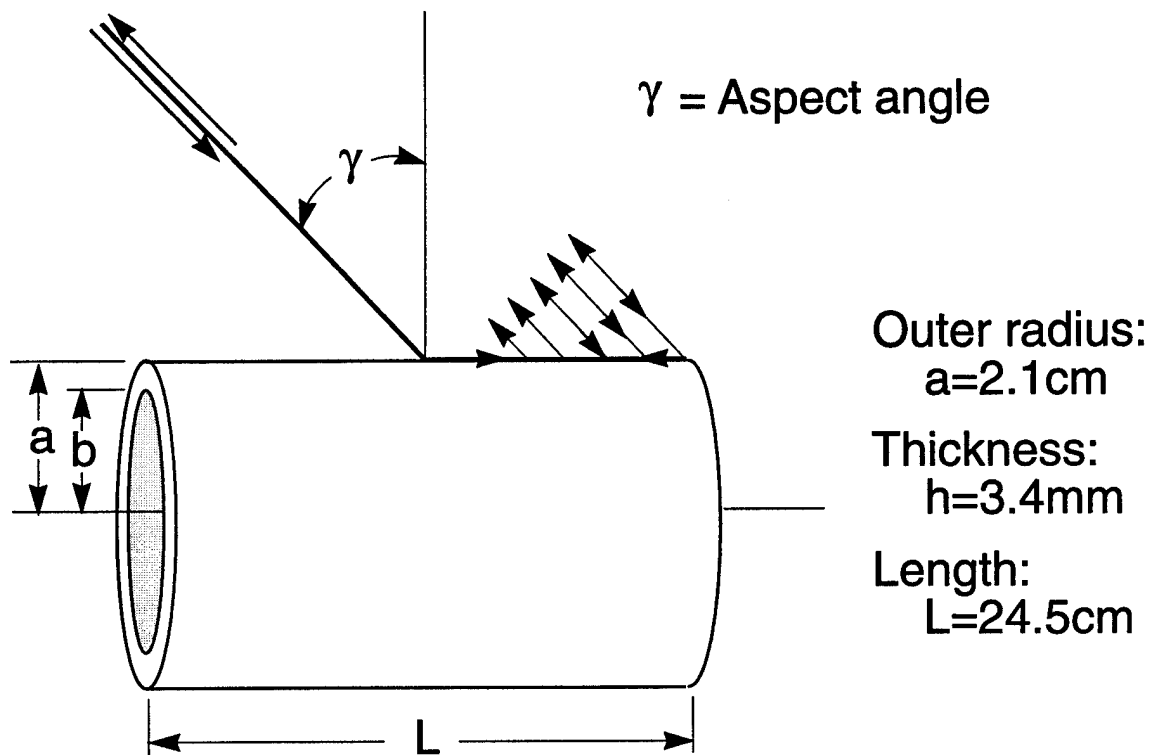

Figure 1

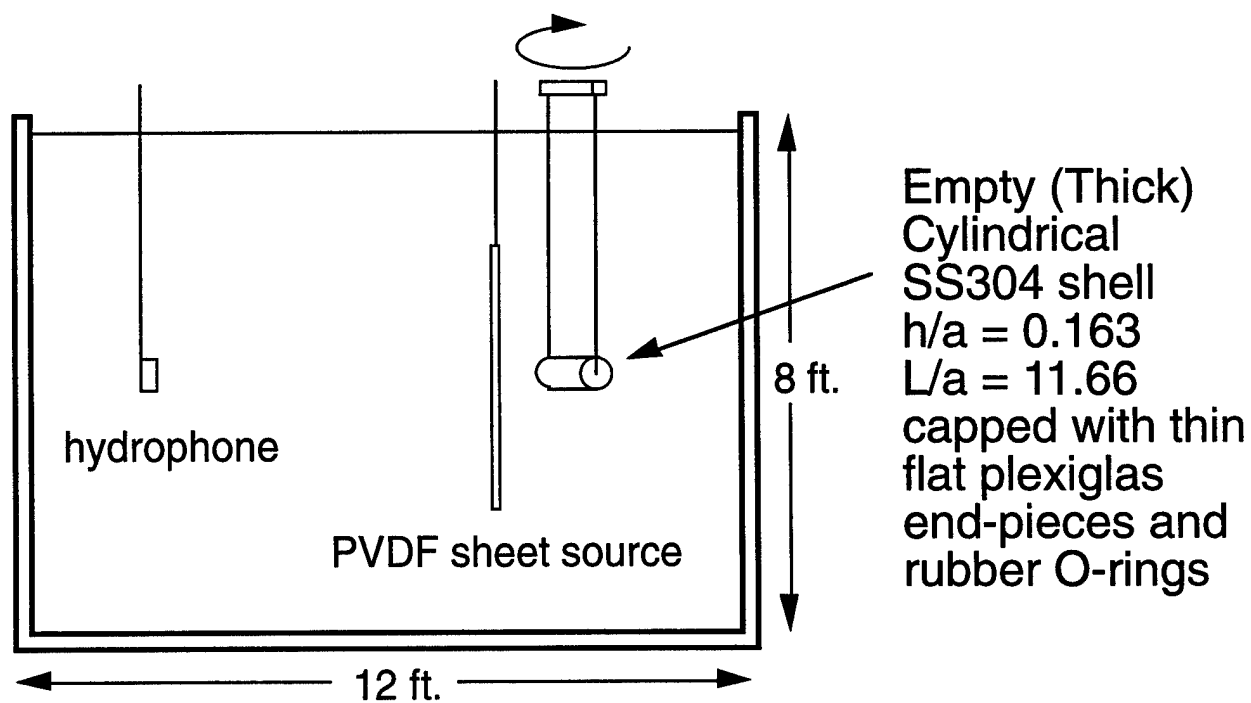

Figure 2

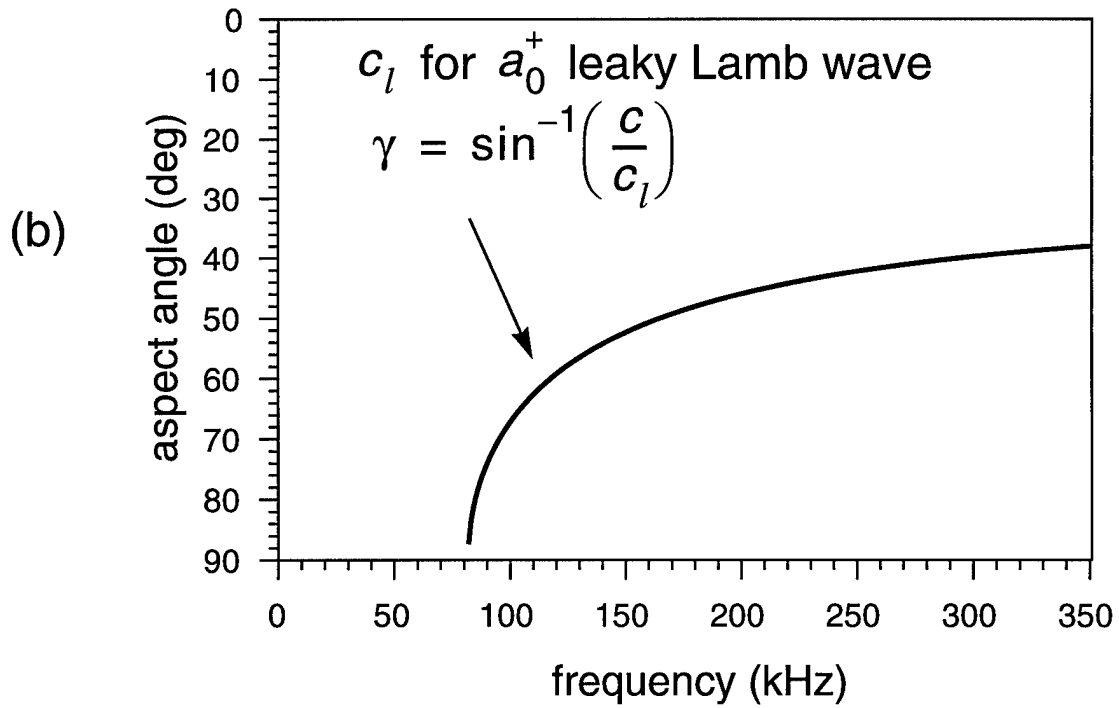
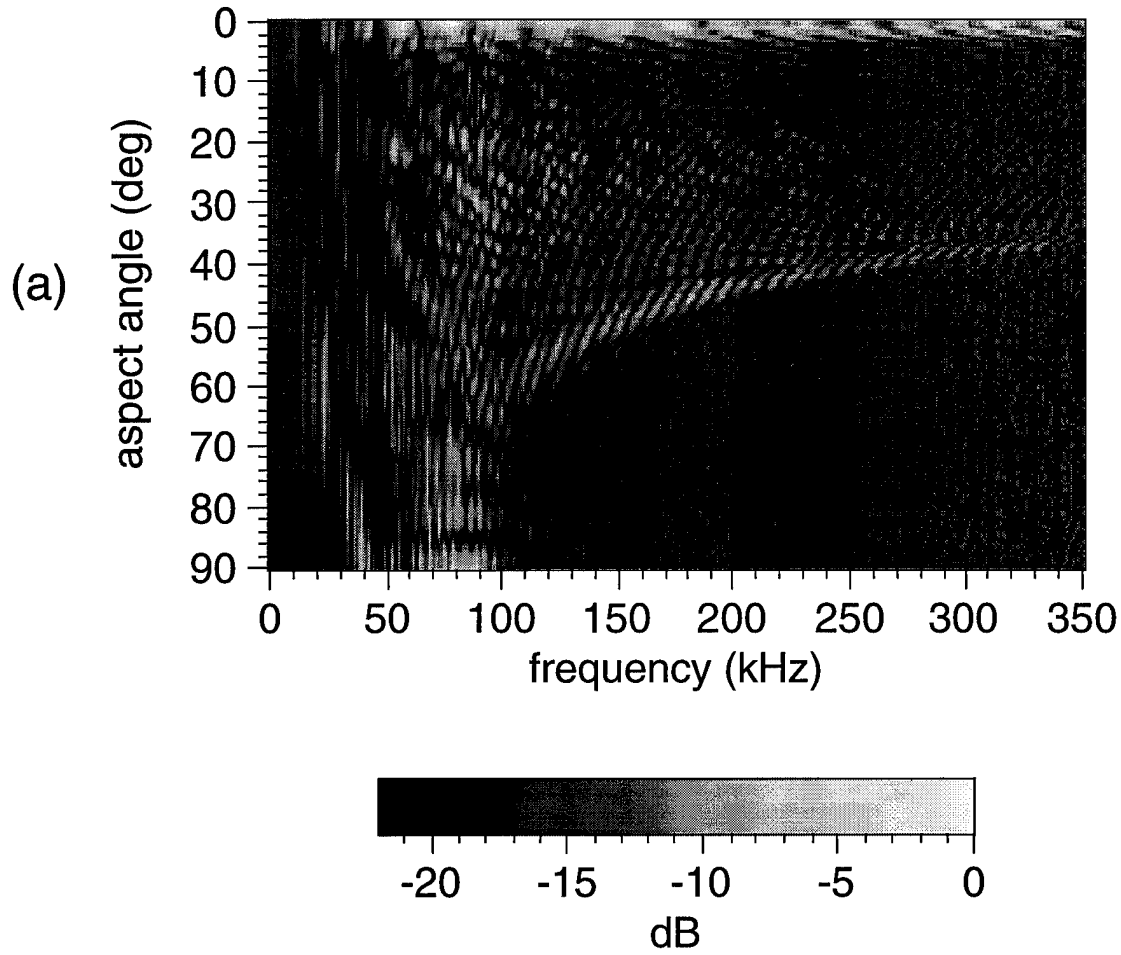

Figure 3

Appendix B: Research Results from Other Grants or Sponsors

For convenience, some recent publications from Marston's program sponsored by other grants are listed below:

1. T. J. Asaki, D. B. Thiessen, and P. L. Marston, "Effect of an insoluble surfactant on capillary oscillations of bubbles in water: Observation of a maximum in the damping," *Phys. Rev. Lett.* 75, 2686-2689 (1995); 75, 4336 (E) (1995).
2. T. J. Asaki and P. L. Marston, "Free decay of shape oscillations of bubbles acoustically trapped in water and sea water," *J. Fluid Mech.* 300, 149-167 (1995).
3. S. F. Morse, D. B. Thiessen, and P. L. Marston, "Capillary bridge modes driven with modulated ultrasonic radiation pressure," *Phys. Fluids* 8, 3-5 (1996).

In the following report, Mark J. Marr-Lyon presented the results of observations of single bubble sonoluminescence (SBSL) in magnetic fields up to 0.6 T:

Mark J. Marr-Lyon, "The effect of magnetic fields on a sonoluminescing bubble," M.S. Degree Project Report (December 1995).

The SBSL of a bubble in water could be easily observed by eye but there were no obvious effects of the B field detectable with available instrumentation.

DISTRIBUTION LIST
 UNDER GRANT N00014-92-J-1600
 ANNUAL SUMMARY REPORT

DR LOGAN E HARGROVE ONR 331
 OFFICE OF NAVAL RESEARCH
 800 NORTH QUINCY STREET
 ARLINGTON VA 22217-5660

2 COPIES

DEFENSE TECHNICAL INFORMATION CENTER
 8725 JOHN J KINGMAN ROAD
 STE 0944
 FT BELVOIR VA 22060-6218

2 COPIES

ADMINISTRATIVE GRANTS OFFICER
 OFFICE OF NAVAL RESEARCH
 RESIDENT REPRESENTATIVE N63374
 UNIV OF WASHINGTON UNIV DISTRICT
 RM 410 1107 NE 45TH ST
 SEATTLE WA 98105-4631

DIRECTOR NAVAL RESEARCH
 LABORATORY
 ATTN CODE 2667
 4555 OVERLOOK AVENUE SW
 WASHINGTON DC 20375-5326

NAVAL POSTGRADUATE SCHOOL
 TECHNICAL LIBRARY CODE 0212
 MONTEREY CA 93943

NAVAL SURFACE WARFARE CENTER
 COASTAL SYSTEMS DIVISION
 TECHNICAL LIBRARY
 PANAMA CITY FL 32407-5000

SUPPLEMENTAL DISTRIBUTION TO RESEARCH PARTICIPANTS AND TO
 OTHERS COUPLED WITH THE PROGRAM (1 COPY EACH)

G KADUCHAK
 APPLIED RESEARCH LABORATORY
 ADVANCED SONAR DIVISION
 UNIVERSITY OF TEXAS AT AUSTIN
 PO BOX 8029
 AUSTIN TX 78713-8029

J S STROUD
 UNIV OF CINCINNATI COLLEGE OF
 MEDICINE
 DEPT OF RADIOLOGY
 231 BETHESDA AVE E560 MSB
 PO BOX 670579
 CINCINNATI OH 45267-0579

D H HUGHES
 NAVAL RESEARCH LAB CODE 7132
 4555 OVERLOOK AVE SW
 WASHINGTON DC 20375-5350

H J SIMPSON
 NAVAL RESEARCH LAB CODE 7136
 4555 OVERLOOK AVE SW
 WASHINGTON DC 20375-5350

T J MATULA
 APPLIED PHYSICS LABORATORY
 UNIVERSITY OF WASHINGTON
 SEATTLE WA 98105-6698

K L WILLIAMS
 APPLIED PHYSICS LABORATORY
 UNIVERSITY OF WASHINGTON
 SEATTLE WA 98105-6698

K GIPSON
 B T HEFNER
 C KWIATKOWSKI
 S F MORSE
 D B THIESSEN
 DEPARTMENT OF PHYSICS
 WASHINGTON STATE UNIVERSITY
 PULLMAN WA 99164-2814

T J ASAKI
 MS 764
 LOS ALAMOS NATIONAL LABORATORY
 LOS ALAMOS NM 87545

W PATRICK ARNOTT
 ATMOSPHERIC SCIENCES CENTER
 DESERT RESEARCH INSTITUTE
 P O BOX 60220
 RENO NV 89506

C K FREDERICKSON
 PHYSICS DEPARTMENT
 UNIV OF CENTRAL ARKANSAS
 CONWAY AR 72035

S G KARGL
 APPLIED PHYSICS LABORATORY
 UNIVERSITY OF WASHINGTON
 SEATTLE WA 98105-6698

C E DEAN
 PHYSICS DEPT
 GEORGIA SOUTHERN UNIVERSITY
 LANDRUM BOX 8031
 STATESBORO GA 30460

OTHER SUPPLEMENTAL DISTRIBUTION (1 COPY EACH)

D G TODOROFF
 NAVAL SURFACE WARFARE
 CENTER
 COASTAL SYSTEMS DIVISION
 PANAMA CITY FL 32407-5000

ALLAN D PIERCE
 DEPT OF AEROSPACE & MECH ENGR
 BOSTON UNIVERSITY
 110 CUMMINGTOWN STREET
 BOSTON MA 02215

RAYMOND LIM
 NAVAL SURFACE WARFARE
 CENTER
 COASTAL SYSTEMS DIVISION
 PANAMA CITY FL 32407-5000

C M LOEFFLER
 APPLIED RESEARCH LABORATORIES
 UNIVERSITY OF TEXAS AT AUSTIN
 AUSTIN TX 78713-8029

F M PESTORIUS DIRECTOR
 APPLIED RESEARCH
 LABORATORIES
 UNIVERSITY OF TEXAS AT AUSTIN
 AUSTIN TX 78713-8029

J W DICKEY
 CARDEROCK DIVISION CODE 2704
 NAVAL SURFACE WARFARE CENTER
 ANNAPOLIS MD 21402

ROGER H HACKMAN
 LOCKHEED MISSILES & SPACE
 ORGN 91-10 B255
 PALO ALTO CA 94304-1191

HENRY E BASS
 DEPT OF PHYSICS AND ASTRONOMY
 UNIVERSITY OF MISSISSIPPI
 UNIVERSITY MS 38677

ANTHONY A ATCHLEY
 DEPARTMENT OF PHYSICS
 CODE PH/AY
 NAVAL POSTGRADUATE SCHOOL
 MONTEREY CA 94943-5000

LAWRENCE A CRUM
 APPLIED PHYSICS LABORATORY
 UNIVERSITY OF WASHINGTON
 1013 NE 40TH STREET
 SEATTLE WA 98105-6698

YVES H BERTHELOT
SCHOOL OF MECHANICAL
ENGINEERING
GEORGIA INSTITUTE OF TECHNOLOGY
ATLANTA GA 30332

MARK F HAMILTON
DEPT OF MECHANICAL ENGINEERING
UNIVERSITY OF TEXAS AT AUSTIN
AUSTIN TX 78712-1063

WOLFGANG H SACHSE
THEORETICAL AND APPLIED
MECHANICS
CORNELL UNIVERSITY
ITHACA NY 14853-1503

IRA DYER
DEPARTMENT OCEAN ENGINEERING
MASSACHUSETTS INST TECHNOLOGY
CAMBRIDGE MA 02139

STEVEN R BAKER
NAVAL POSTGRADUATE SCHOOL
DEPARTMENT OF PHYSICS CODE PH/BA
MONTEREY CA 93943-5004

TIMOTHY K STANTON
WOODS HOLE OCEANOGRAPHIC INST
WOODS HOLE MA 02543

CHARLES F. GAUMOND CODE 7132
NAVAL RESEARCH LABORATORY
4555 OVERLOOK AVE SW
WASHINGTON DC 20375-5350

MOISES LEVY
DEPARTMENT OF PHYSICS
UNIV OF WISCONSIN AT MILWAUKEE
MILWAUKEE WI 53201

ANDREA PROSPERETTI
DEPT OF MECHANICAL ENGINEERING
JOHNS HOPKINS UNIVERSITY
BALTIMORE MD 21218

ROBERT E APFEL
DEPT OF MECHANICAL ENGINEERING
YALE UNIVERSITY
NEW HAVEN CT 06520-2159

L B FELSEN
DEPT OF AEROSPACE & MECH ENGR
BOSTON UNIVERSITY
110 CUMMINGTON STREET
BOSTON MA 02215

LOUIS R DRAGONETTE CODE 7132
NAVAL RESEARCH LABORATORY
4555 OVERLOOK AVE SW
WASHINGTON DC 20375-5350

MICHAEL F WERBY
NRL CODE 7181
STENNIS SPACE CENTER
MS 39529

ANDREW N NORRIS
DEPT MECH AND AEROSP ENGR
RUTGERS UNIVERSITY
P O BOX 909
PISCATAWAY NJ 08855-0909