

# REPORT DOCUMENTATION PAGE

Form Approved  
OMB No. 0704-0188

Public reporting burden for this collection of information is estimated to average 1 hour per response, including the time for reviewing instructions, searching existing data sources, gathering and maintaining the data needed, and completing and reviewing the collection of information. Send comments regarding this burden estimate or any other aspect of this collection of information, including suggestions for reducing this burden, to Washington Headquarters Services, Directorate for Information Operations and Reports, 1215 Jefferson Davis Highway, Suite 1204, Arlington, VA 22202-4302, and to the Office of Management and Budget, Paperwork Reduction Project (0704-0188), Washington, DC 20503.

|                                  |                                 |   |
|----------------------------------|---------------------------------|---|
| 1. AGENCY USE ONLY (Leave blank) | 2. REPORT DATE<br>30 April 1996 | 3. REPORT TYPE AND DATES COVERED<br>Final Technical Report 6/1/93-2/29/96 |
|----------------------------------|---------------------------------|---|

|  |   |
|--|---|
| 4. TITLE AND SUBTITLE<br>(U) Molecular Mixing in Shear Layers Forced by 2-D and 3-D Disturbances | 5. FUNDING NUMBERS<br>PE-61102F<br>PR-2307<br>SA-BS<br>F49620-93-1-0282 |
|--|---|

6. AUTHOR(S)  
Manoochehr M. Koochesfahani

7. PERFORMING ORGANIZATION NAME(S) AND ADDRESS(ES)  
Michigan State University  
East Lansing, MI 48824

AFOSR-TR-96

0377

9. SPONSORING / MONITORING AGENCY NAME(S) AND ADDRESS(ES)  
AFDSR/NA  
110 Duncan Avenue, Suite B115  
Bolling AFB, DC 20332-0001

NA

10. SPONSORING / MONITORING AGENCY REPORT NUMBER  
93-1-0282

11. SUPPLEMENTARY NOTES  
19960726 049

12a. DISTRIBUTION / AVAILABILITY STATEMENT  
Approved for public release; distribution is unlimited

13. ABSTRACT (Maximum 200 words)  
The mixing characteristics of forced two-stream shear layers and wakes have been investigated using both chemically reacting and nonreacting LIF technique. The shear layer results reveal that major modifications of the mixing field occur at relatively high values of  $x^* > 2$ , and not in the enhanced growth region  $x^* < 1$ . The non-dimensional downstream distance is defined by  $x^* \equiv x \lambda f / U_c$ , where  $x$  is the downstream distance,  $\lambda \equiv (U_1 - U_2) / (U_1 + U_2)$ ,  $f$  is the forcing frequency, and  $U_c = (U_1 + U_2) / 2$  where  $U_1, U_2$  are the high and low speed freestream velocities, respectively. The chemically reacting data provide, for the first time, the actual amount of molecularly mixed fluid and the absolute level of mixing enhancement in these forced flows. The highest value of mixed-fluid fraction we have obtained to date in the forced shear layer is about 40% higher than that possible in a high Reynolds number unforced shear layer. The mixed-fluid fraction at the mid-span of our low Reynolds number wake with high-amplitude forcing is at least a factor of two higher than that possible in high Reynolds number liquid mixing layers, and about 60% higher than in gas phase shear layers. The important conclusion is that a low Reynolds number flow, when forced appropriately, can be a better "mixer" than a very high Reynolds number flow.

14. SUBJECT TERMS  
Turbulent Mixing, Forced Shear Layers, Forced Wakes

15. NUMBER OF PAGES  
14

16. PRICE CODE

17. SECURITY CLASSIFICATION OF REPORT  
Unclassified

18. SECURITY CLASSIFICATION OF THIS PAGE  
Unclassified

19. SECURITY CLASSIFICATION OF ABSTRACT  
Unclassified

20. LIMITATION OF ABSTRACT  
UL

**Molecular Mixing in Shear Layers Forced by  
2-D and 3-D Disturbances**

Manoochehr M. Koochesfahani\*

Department of Mechanical Engineering  
Michigan State University  
East Lansing, Michigan 48824

Air Force Office of Scientific Research  
Grant No. F49620-93-1-0282  
**Final Technical Report**

30-April-1996

---

\* Associate Professor; Principal Investigator.

## 1. Introduction

Experimental results and recent models of turbulent mixing in two-stream shear layers indicate that the mixed-fluid fraction in a "natural" layer decreases with increasing Reynolds number at high Reynolds numbers [1]. This important finding suggests that the natural state of a turbulent flow may not offer the best choice for high mixing efficiency. The purpose of this research program is to explore the possibility of using perturbations to alter the natural mixing behavior of shear layers and wakes. The investigation attempts to determine the influence of 2-D and 3-D disturbances on the flow structure and scalar mixing field in shear layers and wakes. The goal is to identify the range of forcing parameters for which there is a marked influence on the scalar mixing field, and the mechanisms by which perturbations affect the entrainment and mixing of species in these flows. This identification is needed for the purpose of mixing control. This final report provides a brief summary of the highlights of our findings. Most of the results have been described in greater detail previously [2-10].

## 2. Summary of Findings

Chemically reacting LIF measurements were performed over the past year in order to establish the absolute measures of molecular mixing in the forced shear layers and wakes under investigation. The conclusions below are based on extensive passive scalar LIF data and the recent chemically reacting data.

- Significant effects in all aspects of the mixing field for both 2-D and combined 2-D/3-D forcing occur at high values of non-dimensional variable  $x^*$  (see Section 2.1). These effects include a marked increase in mixing efficiency (i.e. mixed-fluid fraction  $\delta_m/\delta_i$ ) and a major change in the mixture composition. Data point to the region  $x^* > 2$  as the range where one should look for the major effects of forcing on scalar mixing and not so much the initial enhanced growth region corresponding to  $x^* < 1$ .
- Estimates of molecular mixing based on chemically reacting data indicate that the highest value of mixed fluid fraction obtained so far in the forced shear layer is about 40% higher than the natural layer (see Section 2.1). Since the mixed fluid fraction does not increase with increasing Reynolds number, we arrive at the important result that an appropriately forced turbulent shear layer at low Reynolds number ( $\approx 5,500$  in this case)

can be a much better mixer than an unforced layer at a Reynolds number many times larger.

- The amount of molecularly mixed fluid in our forced low Reynolds number wake was measured using the chemically reacting LIF technique (see Section 2.2). Data indicate that the mixed fluid fraction at center span is at least a factor of two higher than that in high Reynolds number liquid mixing layers, and about 60% higher than in gas phase shear layers. This mixing improvement is quite impressive when we consider the factor of 1,000 Schmidt number difference between gas and liquid. Again, the main message here is that a low Reynolds number flow, when forced appropriately, can easily outperform the mixing levels in very high Reynolds number flow.

In the sections which follow, the highlights of the data responsible for the above conclusions are presented,

## 2.1 Forced Shear Layer Results

In this section recent non-reacting and reacting data are presented suggesting that large changes in the scalar mixing field occur at high values of non-dimensional distance,  $x^*$ . To put these results into perspective, we first review the growth behavior of forced shear layers. The growth rate characteristics of a forced shear layer have been described in the past<sup>11-13</sup> in terms of a non-dimensional downstream distance  $x^* \equiv x \lambda f / U_c$ . In this expression,  $x$  is the downstream distance,  $\lambda \equiv (U_1 - U_2) / (U_1 + U_2)$ ,  $f$  is the forcing frequency, and  $U_c = (U_1 + U_2) / 2$  where  $U_1$ ,  $U_2$  refer to the high and low speed freestream velocities, respectively. The flow exhibits an enhanced growth rate in the range  $0 < x^* < 1$ . The region  $1 < x^* < 2$  refers to the "frequency-locked" region corresponding to the passage of a non-interacting, equally-spaced, array of vortices and a nearly constant shear layer thickness. The range  $x^* > 2$  corresponds to the gradual re-adjustment to the growth characteristics of the unforced layer.

In our studies of scalar mixing, we use the passive scalar LIF technique to map out the spatial and temporal evolution of the concentration field. Results are reported in terms of

the concentration pdf and various indicators of the behavior of the mixing field. Since the passive scalar approach typically provides only an upper bound to the amount of mixed fluid, chemically reacting experiments are also performed for some cases in order to determine the absolute value of the amount of molecularly mixed fluid, and confirm the trends based on the passive scalar data.

We will examine here the data from purely 2-D forcing of shear layers as well as simultaneous 2-D/3-D forcing. In the case of purely 2-D forcing, we have used sinusoidal perturbations by either oscillating the high-speed freestream speed<sup>2</sup> or oscillating an airfoil downstream of the splitter plate tip<sup>3</sup>. For 3-D forcing, we have concentrated on the effects generated by a single spanwise disturbance element on the splitter plate<sup>5,7,9</sup>. The disturbance source is a cylindrical peg placed at the mid-span location on the low-speed side of the splitter plate. We discuss below the case  $U_1 = 40$  cm/s,  $U_2 = 20$  cm/s and forcing frequencies  $f = 2, 4, 8, 16$  Hz; the data presented are mostly at a downstream location  $x = 17$  cm. The local (unforced) shear layer Reynolds number at this station was about 5,500 which was determined to be at the end of the mixing transition<sup>3</sup>. The natural shear layer roll-up frequency was  $f_o \approx 27$  Hz. Note that we go through a range of  $x^*$  values in this case by varying the forcing frequency instead of moving farther downstream. This was dictated by the test section size limitations of our smaller mixing layer apparatus.

### **Total Amount of Mixed Fluid**

The behavior of the mixing efficiency for all the cases studied is depicted in Figure 1 in terms of the span-averaged mixed-fluid fraction. The mixed-fluid fraction,  $\delta_m/\delta_1$ , is the fraction of the layer width  $\delta_1$  occupied by the total amount of mixed fluid as quantified in terms of the mixed-fluid thickness  $\delta_m$ . The data in this figure are from passive scalar measurements; while the absolute values of mixing are not reliable, the indicated trend is.

The main result in Figure 1 is that the data from purely 2-D forcing (regardless of the forcing method and forcing amplitude) and combined 2-D/3-D forcing all follow a similar trend. The mixed-fluid fraction initially decreases and is lower than the unforced case in the range  $x^* < 1.5$ . Mixing enhancement over the unforced case occurs for  $x^* > 1.5$ . It is not known if the increasing trend observed up to  $x^* = 3$  will continue beyond that point. We do note that with combined 2-D/3-D forcing, there is more mixed fluid compared to 2-D forcing alone (compare • with \* symbols).

The trend in Figure 1 is corroborated by chemically reacting data as shown in Figure

2. The actual amount of mixed fluid in the unforced case is measured to be  $\delta_m/\delta_1 = 0.31$  which, as expected, is lower than the passive scalar estimate. The amount of mixed fluid reported here for the unforced shear layer is in agreement with previous data of this quantity above the mixing transition. Note that the largest value of forced layer mixed-fluid thickness in Figure 2 is about 40% higher the unforced case. Since the amount of mixing in a natural shear layer does not increase beyond the mixing transition, it can be concluded that a lower Reynolds number shear layer forced appropriately is a much more efficient "mixer" than an unforced high Reynolds number layer.

The behavior of the total amount of mixing, shown in Figures 1 and 2, can be qualitatively understood if we examine the streamwise structure of the flow. The regions of the flow corresponding to the enhanced growth and the frequency-locked regions are indeed wider than the unforced layer. However, these regions consist of very large structures separated by a well-defined braid and much more pronounced and larger entrainment tongues. *The main message here is that, while the mixing layer has entrained a lot more fluid, most of it is still unmixed.* Therefore, it may not be surprising that these two cases are not better "mixers" than the unforced case. In contrast, the region of re-adjustment to the unforced behavior ( $x^* > 2$ ), the system of organized large scale structures and braids is broken down through a series of vortex interactions which has not been investigated much to date. Interestingly, this is the region where we found the highest value of mixed-fluid fraction (i.e.  $x^* = 3$  in Figure 1).

The behavior described above relies on the average 2-D structure of the flow and, therefore, applies also to the case of purely 2-D forcing. In this case, however, the initial decrease in mixed-fluid fraction is expected to be even more pronounced since the additional mixing mechanisms due to the imposed 3-D forcing are absent. This conjecture is supported by the data in Figure 1. It may be possible that under sufficiently strong 3-D forcing, the average 2-D behavior is suppressed leading to a much different picture from that in Figure 1. This scenario can be of major practical interest and needs to be investigated. At this stage, we do not know if the increasing trend in mixing will persist beyond  $x^* = 3$ , or similar phenomena occur at much higher Reynolds numbers.

### Composition of Mixed Fluid

The discussion above relates to the behavior of the total amount of mixing as  $x^*$  increases. When the control of the scalar mixing field is the concern, this information is incomplete without a knowledge of the mixed-fluid composition. Clearly it is undesirable if a flow control strategy results in enhanced mixing at an unwanted mixture composition. In this section we will show preliminary results which indicate that the composition of mixed fluid goes through dramatic changes with increasing  $x^*$ .

The majority of the results discussed below are based on LIF mapping of the *spanwise* (i.e.  $y$ - $z$  plane) flow structure and the passive scalar mixing field at  $x = 17$  cm with either purely 2-D forcing or combined 2-D/3-D forcing. As before, 2-D forcing frequencies  $f = 4, 8, 16$  Hz were used corresponding to  $x^* \approx 0.75, 1.5, 3.0$  at this particular  $x$  location. We normally describe the composition distribution of the scalar mixing field in terms of the probability density function (pdf) of the concentration field  $\xi$ . Such detailed information, though available, would be unwieldy for the purposes of discussion here. Instead, we have extracted from the pdf's the *average* concentration of mixed fluid  $\xi_M$  in order to highlight the observed effects. Note that this quantity represents the average mixed-fluid concentration across the entire width of the layer (i.e. it is integrated along  $y$  direction).

The variation of the average mixed-fluid concentration,  $\xi_M(z)$ , over the central 60% of the span is shown in Figure 3 for the various frequencies under purely 2-D forcing. We note that the unforced layer and  $f = 4, 8$  Hz cases exhibit little spanwise variation. More importantly, the mixed-fluid concentration remains nearly unaffected in the regions of enhanced growth ( $f = 4$  Hz,  $x^* = 0.75$ ) and zero growth ( $f = 8$  Hz,  $x^* = 1.5$ ). A large decrease in  $\xi_M(z)$  is observed, however, as we go to  $f = 16$  Hz,  $x^* = 3.0$ , corresponding to the region of re-adjustment to the unforced growth rate. These results have been also confirmed by our chemically reacting data.

When combined 2-D/3-D forcing is used, see Figure 4, the unforced layer and  $f = 4, 8$  Hz cases exhibit a well-defined spanwise variation in  $\xi_M(z)$  with a lower mixed-fluid concentration at mid-span and higher concentrations at off-center span locations. This trend reverses entirely at  $f = 16$  Hz. We note that, as for 2-D forcing alone, the average mixed-fluid concentration changes very little for  $x^* = 0.75$  and 1.5. Once again, by  $x^* = 3.0$  ( $f = 16$  Hz) a large qualitative change in mixture composition has occurred.

The results just presented on the mixed-fluid composition suggest that very interesting

phenomena begin to appear when we go to high values of  $x^*$ . This is the first time we have been able to show that composition modification of such magnitude (see Figures 3 and 4) is even possible. Note for example in Figure 3 that 2-D forcing has resulted in a mixture composition at  $x^* = 3$  ( $f = 16$  Hz case) with an average concentration  $\xi_M \approx 0.5$  (see also Figure 5 shown later). This means a mixture with a 1:1 high-speed/low-speed fluid. Such a mixture composition is not possible in a natural shear layer with the velocity ratio  $U_1/U_2 = 2$  of the current experiments. *We have thus generated a two-stream shear layer, with one speed twice the other, but whose mixture composition is more like that of a wake flow with equal speeds.*

The fundamental mechanisms responsible for these mixing modifications are not clearly understood. We do not know if even more changes (i.e. more control possibilities) can occur beyond  $x^* = 3$ . It is not known if such composition modifications will persist at much higher Reynolds numbers, which are of practical interest.

In considering the data in Figure 3, an explanation for the dramatic shift of the composition toward a concentration of 0.5 (i.e. 1:1 mixture ratio) may be attempted solely on the basis of quasi 2-D structures. The entrainment ratio  $E$  into a shear layer has been connected by Dimotakis<sup>14</sup> to the upstream/downstream asymmetry of the large scale structure spacing. The 2-D forced shear layer at  $x^* = 3$  has already passed through the frequency-locked region  $1 < x^* < 2$ . This region is characterized by equally-spaced large structures. The upstream/downstream symmetry of the structure spacing would imply a unity entrainment ratio,  $E = 1$ , in this region. Because there is a delay between fluid entrainment and ultimate mixing, at some value of  $x^*$  beyond 2, the mixture concentration is expected to decrease toward that corresponding to the unity entrainment ratio, namely  $\xi = 0.5$ . While this picture may seem consistent with our results, the intriguing question is why the frequency-locked region should affect the mixture composition at all; the nearly zero growth rate in this region implies zero entrainment of additional fluid!

With the addition of 3-D forcing (in our case a localized disturbance in span), a well-defined wavy pattern develops across the span which is connected with the signature of the streamwise structures in the flow, see Figure 4. Even though the underlying streamwise structure at the measurement location  $x = 17$  cm has not been identified, its net effect is to provide a new mechanism to entrain and mix preferentially across the span. Since the spanwise pattern in the average mixed-fluid concentration remains the same for  $f = 0, 4, 8$  Hz, we infer that the streamwise structure must have maintained a similar arrangement

even as it interacts with the spanwise structures resulting from the imposed 2-D forcing. It is clear that by  $x^* = 3$  the streamwise structure must have changed completely in order to have caused the reversal of the spanwise pattern in the average concentration of mixed fluid. The nature of the interplay between the imposed 2-D and 3-D structures responsible for this behavior needs further investigation.

There is yet another very interesting observation in the case of combined 2-D/3-D forcing. Even though there are large spanwise variations in Figure 4, the *span-averaged* mixed-fluid concentration shows a remarkable lack of sensitivity to the forcing frequency; see Figure 5. The case of purely 2-D forcing, however, initially shows only small variations, followed by a large decrease of mixed-fluid concentration toward a value of 0.5 at  $x^* = 3$  as discussed before. As can be seen, these results are beginning to identify the types of control we can exert on the mixing environment. By using only 2-D forcing, we can change (decrease, in this case) the mixed-fluid concentration across the span while keeping the mixture composition nearly uniform in span. In contrast, a combination of 2-D/3-D forcing can be used to maintain a fixed value of span-averaged concentration while causing local spanwise modulations of mixture composition.

## 2.2 Forced Wake Results

Shear layers and wakes at low Reynolds number tend to be poor mixers of reacting species since the mixing interface area to volume ratio is small. The resulting chemical reaction and combustion are, therefore, not extensive. One approach used for mixing enhancement is to impose a periodic spanwise disturbance upon the initially nominally 2-D vorticity field in these flows<sup>15-21</sup>. The main ingredient in this approach is the generation of streamwise vorticity through the vorticity reorientation and stretching mechanism leading to an increase of small scales and enhancement of mixing.

Our investigation addresses a different approach to mixing enhancement in a wake flow. Here, high amplitude 2-D perturbation of the wake is used to generate strong spanwise vortices whose interaction with the side walls of a confining flow facility results in a dramatic increase in streamwise vorticity, three-dimensionality, and chemical product. The plausibility of this type of forcing for mixing enhancement was first noted by Roberts<sup>22,23</sup> based on flow visualization of a wake forced at about twice the natural Karman shedding

frequency. These studies, however, provided only integrated plan and side views of the flow and passive scalar data across the wake width at the mid-span location. We recently carried out a complete mapping of the spanwise structure and distribution of the passive scalar field<sup>4,6</sup>. Since a passive scalar approach can only provide an upper bound to the actual extent of molecular mixing<sup>24,25</sup>, chemically reacting experiments were also executed to provide data on the actual amount of molecular mixing occurring in this flow and the absolute level of mixing enhancement achieved. This work is part of the M.S. thesis of Mr. Kirk Nelson and has been accepted for presentation at the International Mechanical Engineering Conference and Exposition, in Atlanta, Georgia in November 1996.

### **Experimental Facility and Instrumentation**

The experiments were performed in a gravity-driven liquid two-stream shear layer apparatus with a test section of dimension 4 (height)  $\times$  8 (span)  $\times$  32 cm (length). Two-dimensional perturbations were introduced into the flow by sinusoidally oscillating one of the free streams using an oscillating bellows mechanism in one of the supply lines. The bellows was driven by an electro-magnetic shaker whose command signal originated from a function generator. The details of the flow apparatus and the forcing mechanism are described elsewhere<sup>2,4</sup>. For the results described here, the two free stream speeds were set to  $U_1 = U_2 = 10$  cm/s to generate a nominally 2-D wake. The initial Reynolds number,  $Re_\theta$ , based on the free stream speed and the wake momentum thickness at the splitter plate tip was about 100. The natural Karman shedding frequency at these flow conditions is approximately 6 Hz. The wake was forced at near the Karman shedding frequency at different amplitudes. The three forcing amplitudes (i.e. velocity perturbation rms amplitude) investigated were estimated to correspond to 1%, 6%, and 10% of the mean free stream speed.

The molecular mixing field was measured using chemically reacting laser induced fluorescence (LIF) diagnostics<sup>25</sup>. An acid-base chemical reaction was used in conjunction with a fluorescent pH indicator (disodium fluorescein) to directly monitor the extent of molecular mixing. The equivalence ratio of the freestream concentrations was set to a low value ( $\phi = 0.06$ ) so that practically all of the molecularly mixed fluid would be accounted for. Recording the fluorescence intensity allowed a quantitative measurement of the normalized product concentration field  $C_p(x,y,z,t)$  through well-established data processing procedures<sup>25</sup>. The LIF measurements were carried out over planes defined by a laser sheet

(thickness about 0.5 mm) aligned along the flow direction at different spanwise ( $z$ ) locations (i.e.  $x$ - $y$  plane) and also perpendicular to the flow direction (i.e.  $y$ - $z$  plane) at different downstream  $x$  locations. See Figure 6.

The fluorescence intensity was recorded by an electronically shuttered (1 ms exposure) CCD camera (SONY XC-77RR) operating at 60 fields/s and acquired onto hard disk in real time by an image acquisition system (Recognition Concepts, Inc., TRAPIX-5500). For each run, 1024 consecutive LIF images were acquired corresponding to about 100 forcing cycles. Product concentration data were typically obtained at  $512 \times 240$  pixels in ( $x$ - $y$ ) plane and  $250 \times 500$  pixels in ( $y$ - $z$ ) plane. The spatial resolution in both ( $x$ - $y$ ) and ( $y$ - $z$ ) planes was about  $160 \times 160 \mu\text{m}$ .

### **Results and Discussion**

Results are discussed here mainly for the highest amplitude (10%) case. Typical digital LIF images illustrating the downstream evolution of the flow structure and product concentration field at the mid-span location are shown in Figures 7a-b. Each figure is a composite of three separate images acquired at different phases of the oscillation cycle. The entire 4 cm height of the test section is shown in these figures.

The unforced flow, Figure 7a, shows the unstable wake. Chemical reaction occurs only at the thin interface separating the two free stream fluids. There is very little molecular mixing in this case. Forcing at near the natural Karman shedding frequency leads to the roll up of an organized vortex array locked to the forcing frequency (Figure 7b). At the early  $x$  locations, chemical reaction occurs in tightly-wound interfaces separating the two free stream fluids. As the flow moves downstream, however, we note a dramatic increase in the small scales and the amount of molecularly mixed fluid in the wake. Note that beyond  $x = 19$  cm the whole height of the test section is filled with mixed fluid. It will be shown later that the amount of chemical product has increased by two orders of magnitude in this case.

The structure of the flow and the product concentration field just described only apply to the mid-span location. The forced flow is highly three-dimensional and the flow behavior is strongly dependent on the span location as illustrated in Figures 7c,d. At a span location slightly off-center, Figure 7c, the flow becomes three-dimensional, and has more chemical product, earlier in the downstream direction. The final extent of mixing appears similar to the mid-span location. Moving farther away along span towards the test

section side walls, Figure 7d, reveals a totally different downstream evolution of the chemical product. The three-dimensionality and molecular mixing increase significantly only initially. Farther downstream the amount of chemical product actually decreases. The LIF images of the spanwise structure of the product concentration field, shown later, will help clarify this seemingly counterintuitive behavior.

In order to quantify the extent of mixing enhancement, we compute the product thickness  $\delta_p$  representing the net amount of chemical product present across the wake width at each downstream location. The product thickness is computed based on the average product concentration profile  $\bar{C}_p$  according to

$$\delta_p(x, z) = \int_{-\infty}^{\infty} \bar{C}_p(x, y, z) dy$$

The downstream variation of the product thickness at mid-span is shown in Figure 8 for different forcing amplitudes. Note the small amount of chemical product in the unforced flow. The rapid increase of the amount of molecular mixing in the high amplitude (10%) case is consistent with the visual data in Figure 7b. The maximum amount of mixed fluid in the high amplitude case is two orders of magnitude higher than the unforced case.

An important aspect of Figure 8 is that the maximum value of product thickness  $\delta_p$  normalized by the local layer width  $\delta_1$  is about 0.4. Since the composition distribution of mixed fluid is expected to be symmetric in a wake resulting in an average mixed-fluid concentration of 0.5, we infer that the mixed-fluid thickness is related to the product thickness according to  $\delta_m = 2\delta_p$ <sup>25</sup>. Therefore, the mid-span of the highly mixed wake has a mixed-fluid fraction of  $\delta_m/\delta_1 = 0.8$ . This value is more than twice the corresponding value for a high Reynolds number liquid shear layer (i.e. 0.29). It is also 60% higher than the high Reynolds number gas phase shear layer (i.e. 0.50). *These results indicate that a low Reynolds number flow that is forced the right way can mix much better than an unforced high Reynolds number flow.*

Since the high amplitude forcing of the wake results in a highly three-dimensional flow, spanwise LIF imaging was carried out to reveal the flow structure and the distribution of the chemical product over the cross-stream ( $y$ - $z$ ) plane. Figure 9 illustrates the downstream evolution of the spanwise flow structure and molecular mixing field for the case of high amplitude (10%) forcing. Each figure illustrates a time sequence ( $\Delta t = 1/60$  s; time increasing from top to bottom) covering one forcing oscillation period. The upstream view of the entire 4 cm  $\times$  8 cm cross section of the flow facility is displayed.

The chemically reacting LIF images in Figure 9 reveal that the forced wake is initially ( $x = 8$  cm) essentially two-dimensional except near the side walls where the flow is

characterized by the presence of streamwise vortices. The streamwise vorticity in this flow is generated by the reorientation and stretching of the primary spanwise vorticity as a result of the shear region in the side-wall boundary layers. The chemical reaction initially occurs predominantly in those regions of streamwise vorticity near the side walls with very little chemical product found in the central 2-D region.

As the forced wake moves downstream, additional streamwise vortices appear and the region containing them moves away from the side walls toward the center span. Meanwhile an increasingly larger portion of the test section is occupied by molecularly mixed fluid. It is very interesting to note that the dramatic enhancement of chemical product at the farthest downstream location is contained within the central portion of the span; the regions near the side walls are practically devoid of any mixed fluid. This is exactly opposite of the behavior at the early  $x$  locations.

### 3. Conclusions

Our extensive passive scalar data on forced shear layers and wakes have been augmented by chemically reacting data. The chemically reacting data corroborate the various trends indicated by the passive scalar data. Both data sets indicate that major modifications of the mixing field in two stream shear layers occurs at relatively high values of  $x^* > 2$  and not in the enhanced growth region  $x^* < 1$ .

The chemically reacting results provide, for the first time, the actual amount of molecularly mixed fluid and the absolute level of mixing enhancement in our forced flows. The highest value of mixed-fluid fraction we have obtained to date in the forced shear layer is about 40% higher than that possible in a high Reynolds number unforced shear layer. The mixed-fluid fraction at the mid-span of our low Reynolds number wake with high-amplitude forcing is at least a factor of two higher than that possible in high Reynolds number liquid mixing layers, and about 60% higher than in gas phase shear layers. The important conclusion is that a low Reynolds number flow, when forced appropriately, can be a better "mixer" than a very high Reynolds number flow.

Three aspects of the current work need to be pursued further. The flow interactions and mechanisms responsible for reported changes in the passive scalar field are not presently clear. In addition, it is not known if the large modifications observed at  $x^* = 3$  will continue beyond this value of  $x^*$ . Finally, the effect of flow Reynolds number has not been addressed; it is currently unclear whether similar results would be found at much higher Reynolds numbers.

## 4. References

1. Dimotakis, P. E. [1989] "Turbulent shear layer mixing with fast chemical reactions," in *Turbulent Reactive Flows, Lecture Notes in Engineering 40*, eds. R. Borghi and S.N.B. Murthy, Springer-Verlag, pp. 417-485.
2. Koochesfahani, M. M. and MacKinnon, C. G. [1991] "Influence of forcing on the composition of mixed fluid in a two-stream shear layer," *Phys. Fluids A*, **3(5)**, pp. 1135-1142.
3. Katch, G. J. and Koochesfahani, M. M. [1993] "Mixing of species in a two-stream shear layer forced by an oscillating airfoil," AIAA Paper 93-0444; also Katch, G. J. [1994] M.S. Thesis, Michigan State University.
4. MacKinnon, C. G. and Koochesfahani, M. M. [1993] "Three-dimensional structure and mixing of a forced wake inside a confined channel," AIAA-93-0658.
5. MacKinnon, C. G. and Koochesfahani, M. M. [1994] "Effects of 2-D and 3-D disturbances on mixing in a shear layer," *Bull. Am. Phys. Soc.*, **39(6)**, 1846.
6. Koochesfahani, M. M., Beresh, S. J. and MacKinnon, C. G. [1994] "Volumetric visualization of 3-D flow structure in a low Reynolds number forced wake," *Bull. Am. Phys. Soc.*, **39(9)**, 1947.
7. Koochesfahani, M. M. [1995] "Molecular mixing in shear layers forced by 2-D and 3-D disturbances," AFOSR Grant No. F49620-93-1-0282 Annual Technical Report, 25-August 1995.
8. Cohn, R. K., Gendrich, C. P., MacKinnon, C. G. and Koochesfahani, M. M. [1995] "Crossflow velocity measurements in a wake flow," *Bull. Am. Phys. Soc.*, **40(12)**, 1962.
9. MacKinnon, C. G. and Koochesfahani, M. M. [1995] "Scalar mixing in a shear layer forced by 2-D and 3-D disturbances," *Bull. Am. Phys. Soc.*, **40(12)**, 2032.
10. Koochesfahani, M. M. and Nelson, K. [1996] "Enhancement of molecular mixing in a low Reynolds number wake inside a confined channel," Accepted in *International Mechanical Engineering Conference and Exposition*, Atlanta, GA, November 17-22, 1996.
11. Oster, D. and Wygnanski, I. [1982] "The forced mixing layer between parallel streams," *J. Fluid Mech.*, **123**, pp. 91-130.
12. Ho, C-M. and Huang, L-S. [1982] "Subharmonics and vortex merging in mixing layers," *J. Fluid Mech.*, **119**, pp. 443-473.
13. Browand, F. K. and Ho, C-M. [1983] "The mixing layer: an example of quasi two-dimensional turbulence," *Journal de Mecanique*, **2**, pp. 99-120
14. Dimotakis, P. E. [1986] "Two-dimensional shear-layer entrainment," *AIAA J.*, **24(11)**,

- 1791-1796.
15. Breidenthal, R. E. [1980] "Response of plane shear layers and wakes to strong three-dimensional disturbances." *Phys. Fluids*, **23**(10), pp. 1929-1934.
  16. Ashurst, W. T. and Meiburg, E. [1988] "Three-dimensional shear layers via vortex dynamics." *J. Fluid Mech.*, **189**, pp. 87-116.
  17. Lasheras, J. C. and Choi, H. [1988] "Three-dimensional instability of a plane free shear layer: an experimental study of the formation and evolution of streamwise vortices." *J. Fluid Mech.*, **189**, pp. 53-86.
  18. Meiburg, E. and Lasheras, J. C. [1988] "Experimental and numerical investigation of the three-dimensional transition in plane wakes." *J. Fluid Mech.*, **190**, pp. 1-37.
  19. Mehta, R. D. and Bell, J. H. [1989] "An experimental study of forced streamwise vortical structures in a plane mixing layer." Presented at the *Australasian Fluid Mechanics Conference*, Melbourne, Australia, Dec. 11-15, 1989.
  20. Rogers, M. M. and Moser, R. D. [1991] "The three-dimensional evolution of a plane mixing layer: The Kelvin-Helmholtz rollup." NASA TM-103856.
  21. Nygaard, K. J. and Glezer, A. [1991] "Evolution of streamwise vortices and generation of small scale motion in a plane mixing layer." *J. Fluid Mech.*, **231**, pp. 257-301.
  22. Roberts, F. A. [1985] "Effects of a periodic disturbance on mixing in turbulent shear layers and wakes." Ph.D. Thesis, Caltech.
  23. Roberts, F. A. and Roshko, A. [1985] "Effects of periodic forcing on mixing in turbulent shear layers and wakes." AIAA-85-0570.
  24. Koochesfahani, M. M. and Dimotakis, P. E. [1985] "Laser induced fluorescence measurements of mixed fluid concentration in a liquid plane shear layer." *AIAA J.*, **23**, pp. 1700-1707.
  25. Koochesfahani, M. M. and Dimotakis, P. E. [1986] "Mixing and chemical reactions in a turbulent liquid mixing layer." *J. Fluid Mech.*, **170**, pp. 83-112.

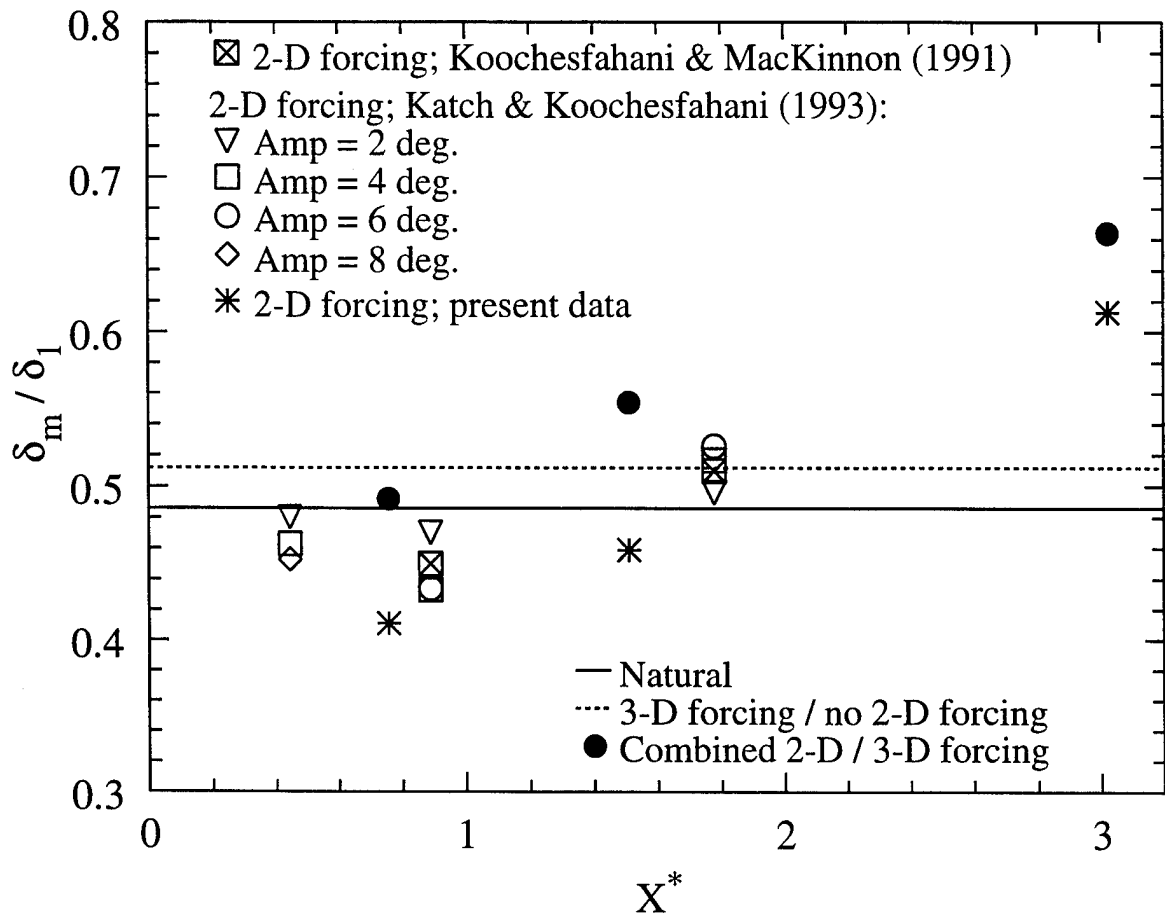

Figure 1. Variation of mixed-fluid fraction versus  $x^*$ .

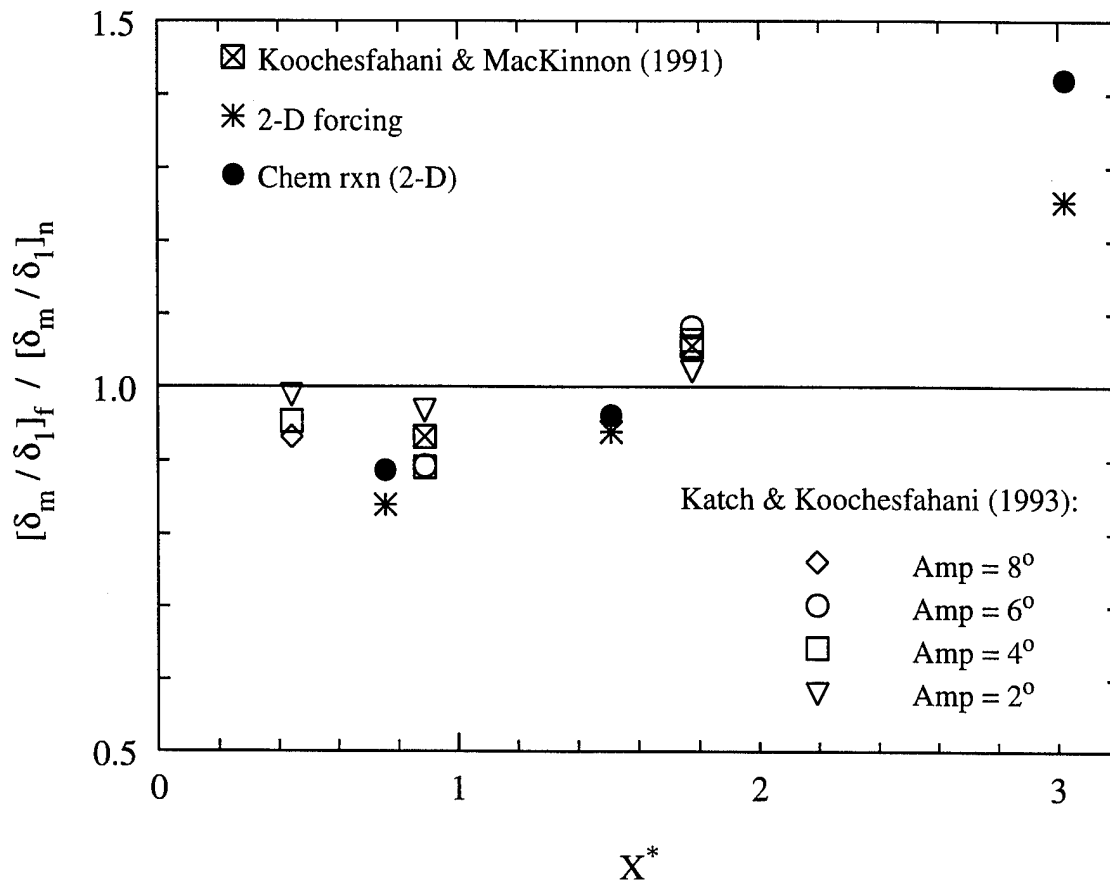

Figure 2. Variation of normalized mixed-fluid fraction versus  $x^*$ . Mixed-fluid fraction in a forced layer  $(\delta_m/\delta_1)_f$  is normalized by the mixed-fluid fraction in the natural layer  $(\delta_m/\delta_1)_n$ .

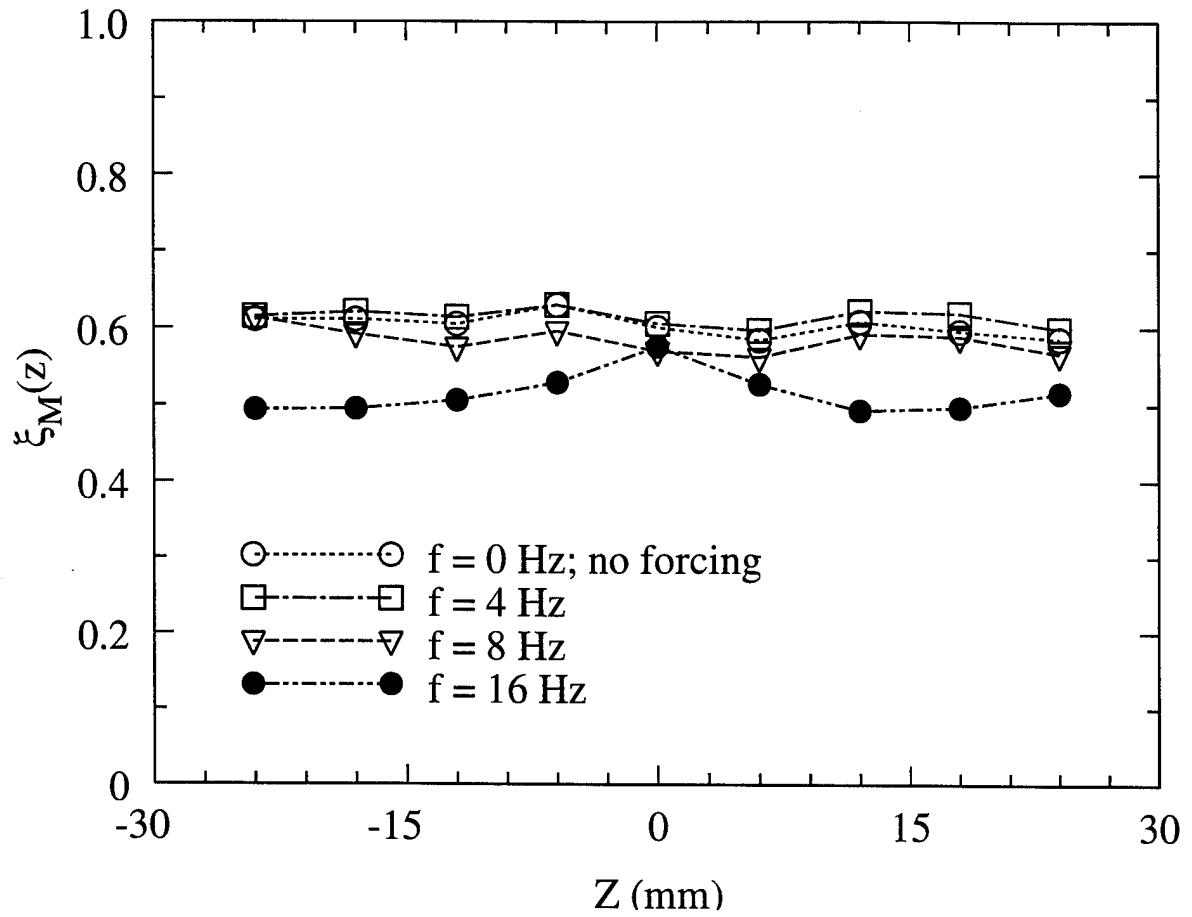

Figure 3. Spanwise variation of average mixed-fluid concentration; 2-D forcing.

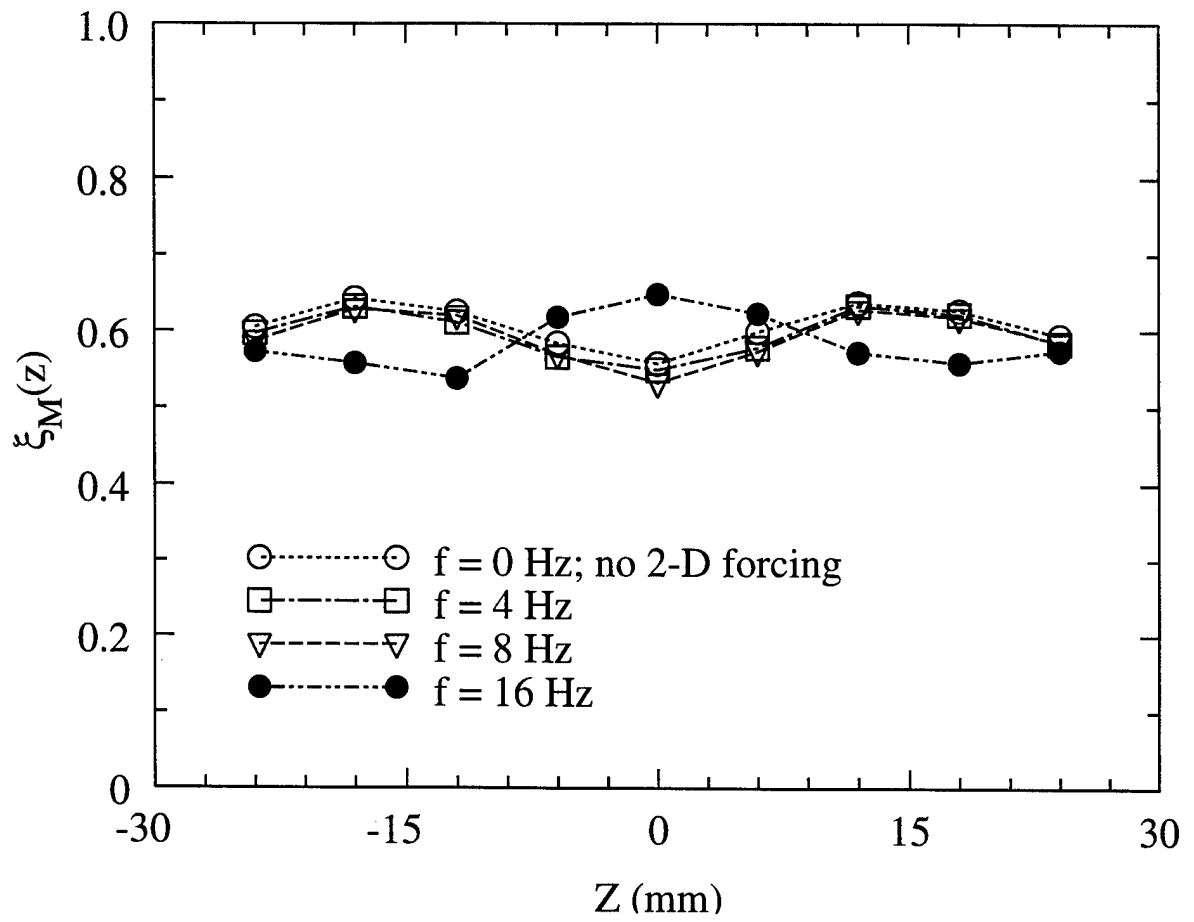

Figure 4. Spanwise variation of mixed-fluid concentration; combined 2-D/3-D forcing.

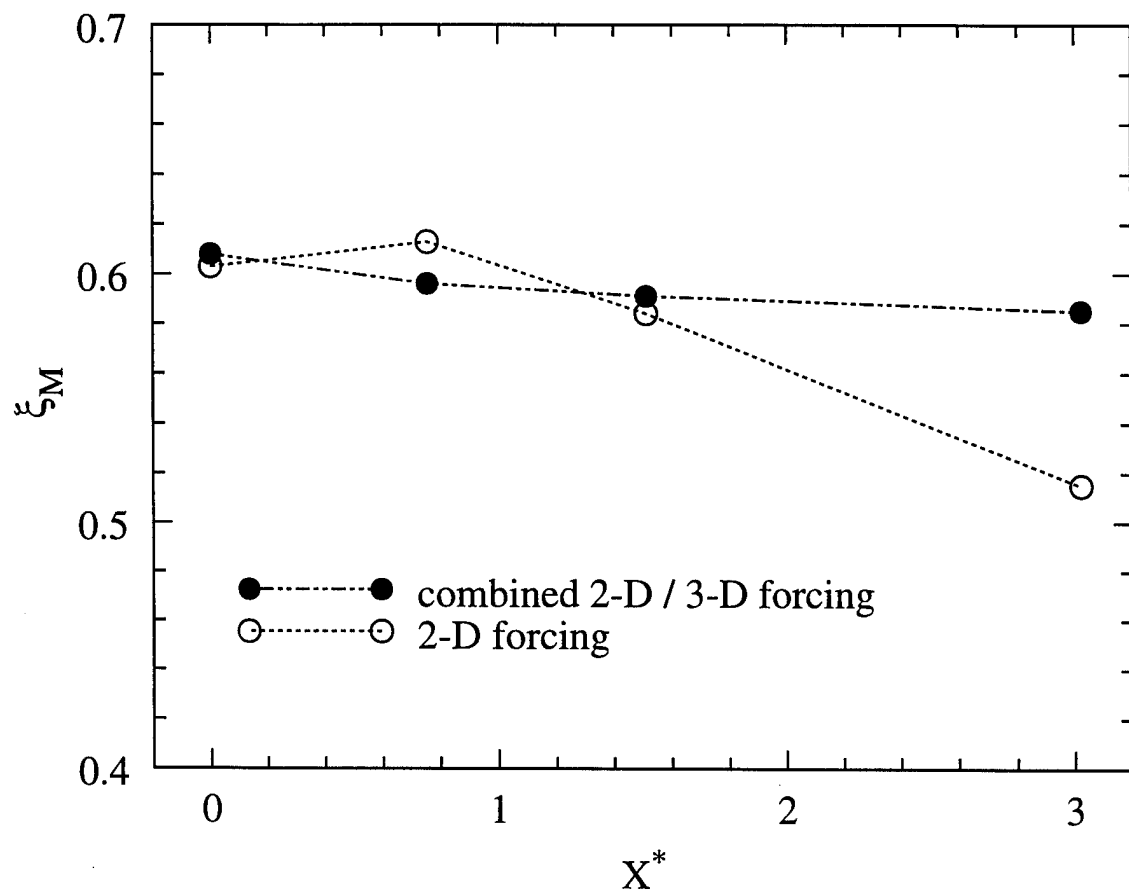
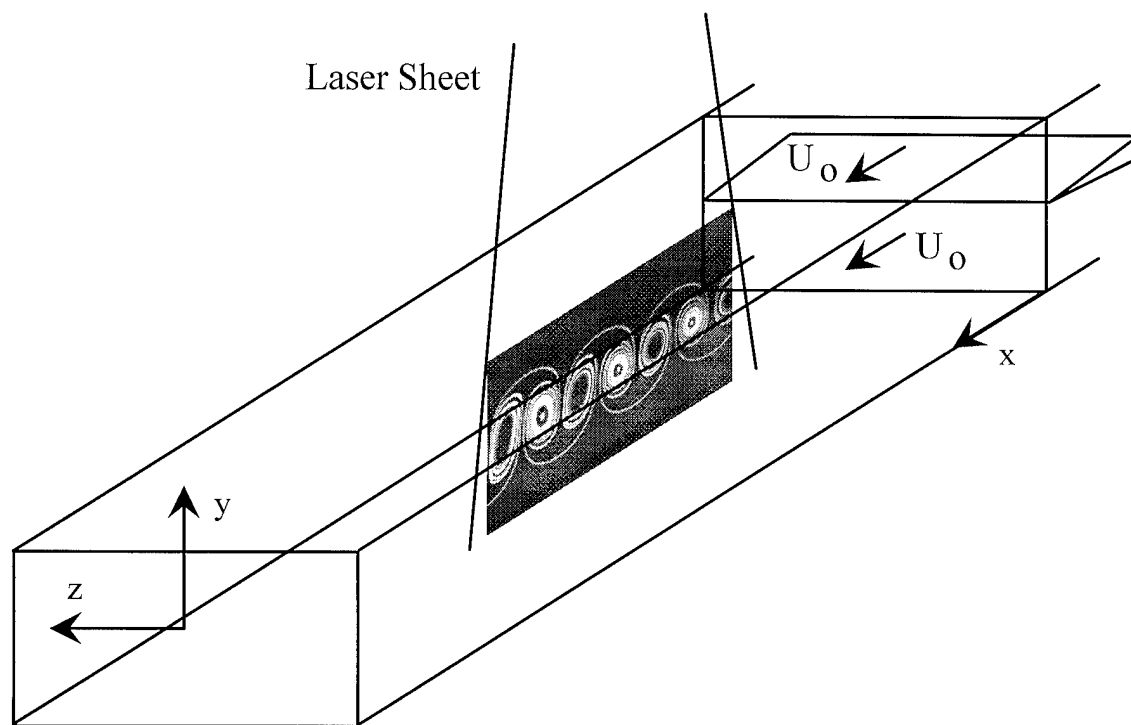
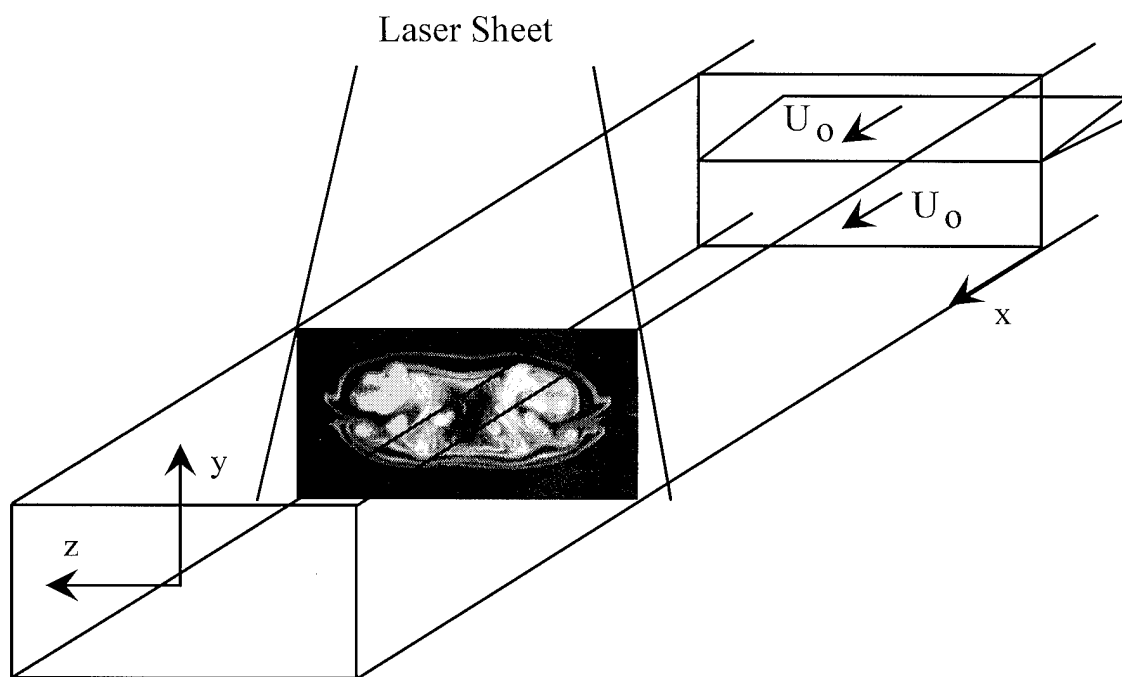

Figure 5. Span-averaged mixed-fluid concentration versus  $x^*$ .



(a) arrangement for streamwise imaging.



(b) arrangement for spanwise imaging.

Figure 6. Laser sheet arrangements for LIF imaging.

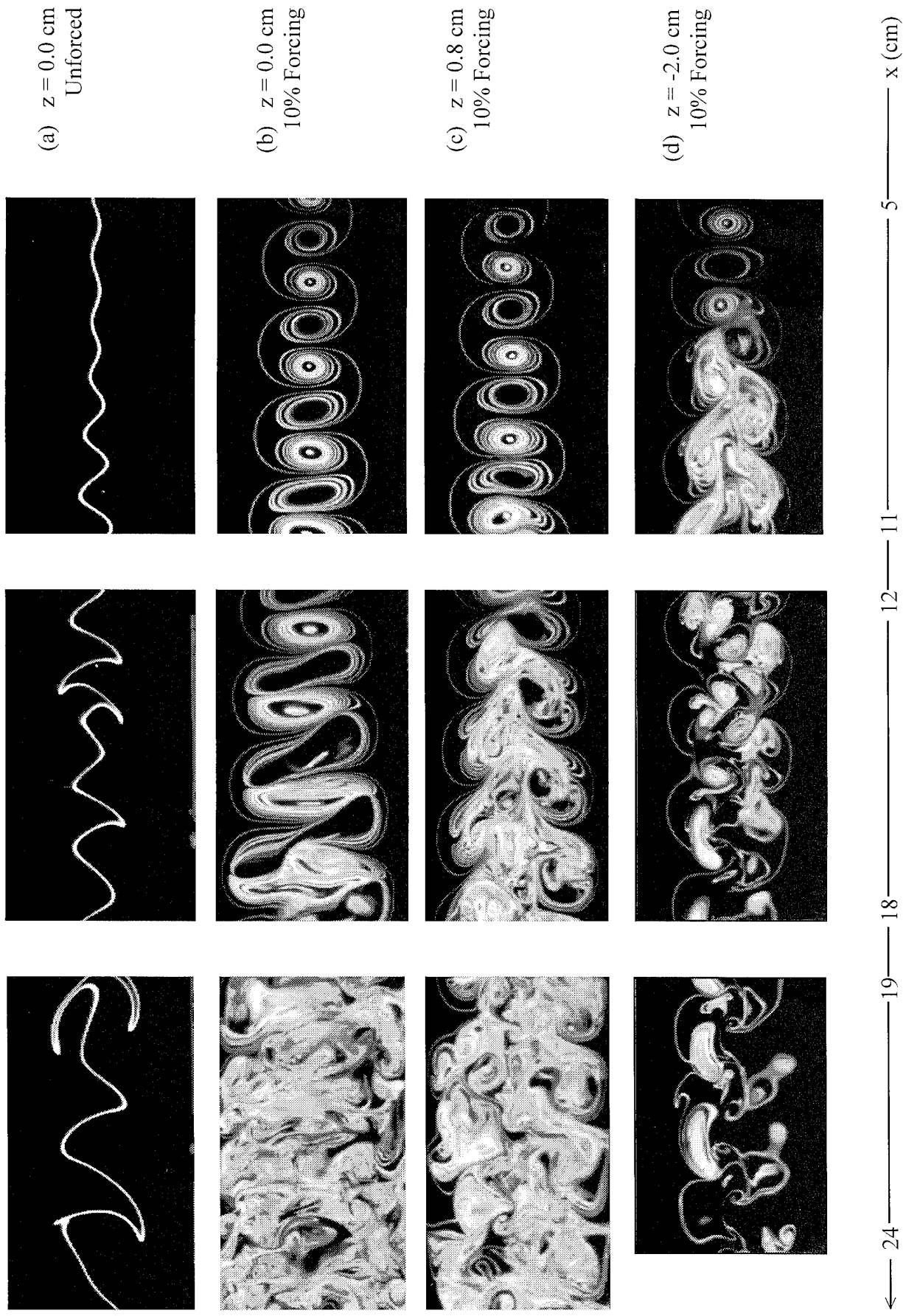

Figure 7. LIF images of the product concentration field in a chemically reacting forced wake. Flow direction is from right to left.

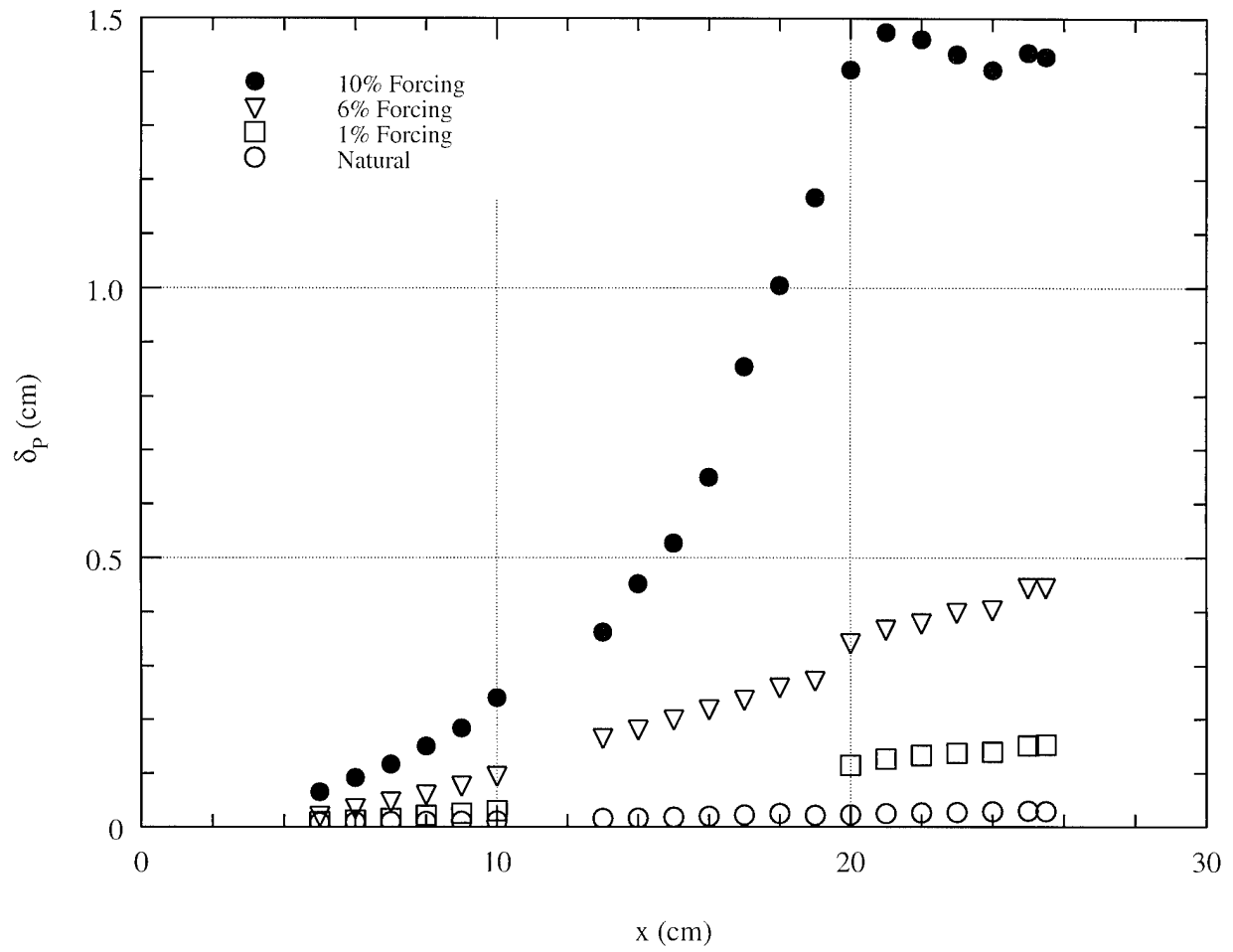

Figure 8. Streamwise variation of the product thickness of a wake forced at different amplitudes;  $z = 0.0$  cm.

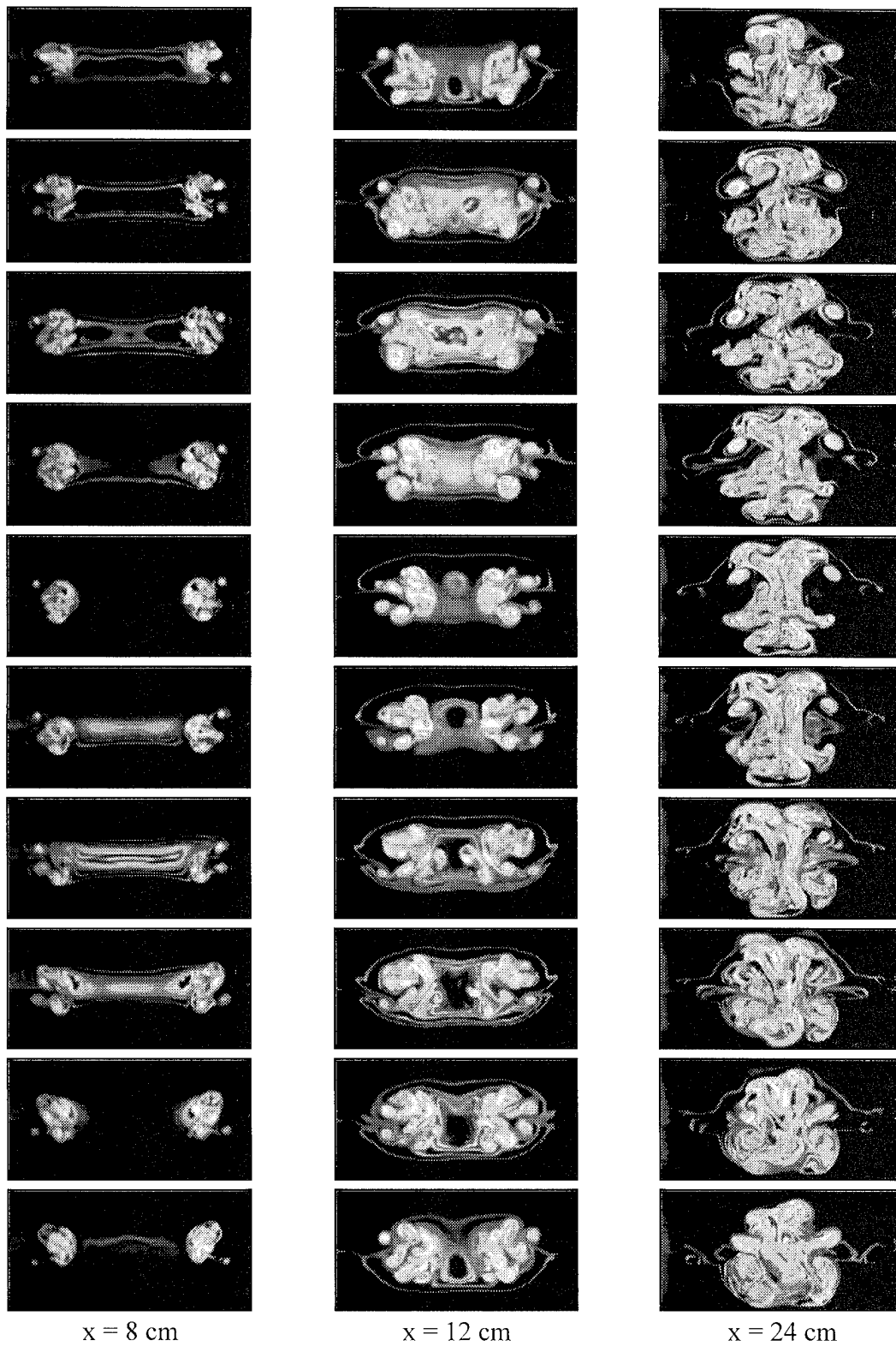

Figure 9. Downstream evolution of the spanwise flow structure and product concentration field in a chemically reacting forced wake. For each case, the image time sequence ( $\Delta t = 1/60 \text{ s}$ ) represents one complete forcing cycle.