

UNCLASSIFIED
SECRET INFORMATION

COPY NO. 4

ASW-21

UNCLASSIFIED

NRL MEMORANDUM REPORT
No. 85

DETECTION OF IONIZED EXHAUST TRAILS
BY AIRBORNE EQUIPMENT

Ralph A. Richardson

OPTICS DIVISION

2 September 1952



NAVAL RESEARCH LABORATORY, WASHINGTON, D. C.

19960729 124

DTIC QUALITY INSPECTED 3

APPROVED FOR PUBLIC RELEASE
DISTRIBUTION UNLIMITED

"A"

UNCLASSIFIED
SECRET

UNCLASSIFIED
SECRET

SECURITY

This document contains information affecting the national defense of the United States within the meaning of the Espionage Laws, Title 18, U.S.C., Sections 793 and 794. The transmission or the revelation of its contents in any manner to an unauthorized person is prohibited by law.

Reproduction of this document in any form by other than activities of the Department of Defense and the Atomic Energy Commission is not authorized unless specifically approved by the Secretary of the Navy or the Chief of Naval Operations as appropriate.

UNCLASSIFIED

SECRET

DISCLAIMER NOTICE

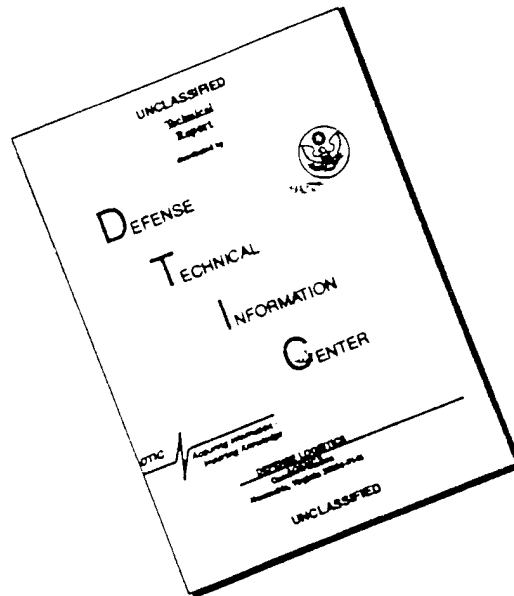

THIS DOCUMENT IS BEST QUALITY AVAILABLE. THE COPY FURNISHED TO DTIC CONTAINED A SIGNIFICANT NUMBER OF PAGES WHICH DO NOT REPRODUCE LEGIBLY.

memorandum

DATE: February 1, 1996

REPLY TO: 5630-014-RAP
ATTN OF:

SUBJECT: Classification of Reports

TO: Code 1221

1. I have reviewed reports FR-5376, FR-5395, FR-5375, FR-5362, FR-5438, FR-4805, MR-85, and MR-463 for reclassification.
2. The most recent of the reports are dated 1959. Three separate phenomenologies are reported in the eight reports. While the physical processes underlying the observed effects are certainly still valid, the details of the observations have changed because of evolution of the objects involved. For example, the conclusions in report 5362 on "The Detection Of Scattered Light From Missiles Below The Horizon" are outdated because of advances in detectors, electronics, and processing capabilities. In my judgment, very little harm can be done to the US from use of this report, and I recommend it be downgraded to Unclassified with unlimited distribution (Distribution Statement A).
3. The observations in report MR-85 on "Detection Of Ionized Exhaust Trails By Airborne Equipment" are similarly out of date because of technology advances, but are also not relevant because of advances in engines and in control of their exhaust. In my judgment, very little harm can be done to the US from use of this report, and I recommend it be downgraded to Unclassified with unlimited distribution (Distribution Statement A).
4. The reports on Project Clinker (FR-5376, FR-5395, FR-5375, FR-5438, FR-4805, and MR-463) deal with a phenomenology which is still under investigation. In my judgment, the reports provide a guide to a phenomenon which could be exploited to the detriment of the US. Consequently, I believe these reports should be maintained at their current level of classification.

Raymond A. Patten, Head
Applied Optics Branch

UNCLASSIFIED
SECURITY INFORMATION

2 September 1952

UNCLASSIFIED

DETECTION OF IONIZED EXHAUST TRAILS
BY AIRBORNE EQUIPMENT

- Ref: (a) NRL Problem NO3-21
(b) Detection of Submarine Exhaust Trails, Dr. George R. Wait,
Dr. Louis F. Drummeter, and Lt.(jg) Robert L. Vader (Secret)
(c) Studies of Atmospheric Ionization (Secret) Admiralty Materials
Laboratory

- I - Studies of Atmospheric Ionization A/24 (E)
- II - Studies of Atmospheric Ionization A/25 (E)
- III - Studies of Atmospheric Ionization A/26 (E)
- IV - Observations in Gamma Fields SA/21 (E)
- V - Snorkel Detection, Exhaust Detection Trails October
1949 SA/22 (E)
- VI - Mobilities of Ions Produced by Flames SA/23 (E)
- VII - The Role of Sulphur Dioxide in the Production of Intermediate
and Large Ions in the Atmosphere SA/24 (E)

- (d) Physics of the Earth VII, Terrestrial Magnetism and Electricity,
edited by J. A. Fleming

1. This work was done under reference (a).

2. One method of finding snorkeling submarines is by detecting the trail of large ions left behind with the exhaust gases. This is done by scooping up the air and collecting the charged particles in an ion chamber. The resulting current is a measure of the ion concentration. References (b) and (c) describe measurements made from surface ships of ion trails left by submarines and other surface ships. Since the speed differential between surface ships and a snorkeling submarine is so low, greater search areas can be covered by making the equipment airborne.

During the winter of 1951-1952 an ion chamber was installed and flown in a K-type airship at Lakehurst, N. J. The purpose of these flights was to investigate the magnitude of ion concentration in exhaust trails from snorkeling submarines. Only one working day with a submarine was available and that under very poor weather conditions. However, exhaust trails were measurable and enough data was taken to show that the signals were large enough to warrant further efforts. Many flights were also made with trails from freighters as targets.

UNCLASSIFIED
SECURITY INFORMATION

UNCLASSIFIED
SECURITY INFORMATION

UNCLASSIFIED

The system installed in the K-85 was designed and built at NRL. Figure 1 is a block diagram of the complete system. Two major objectives guided the design. The system must be free of the drift which accompanies d-c systems and the chamber load resistance must not exceed one megohm in order to minimize the effects of humid meteorological conditions. The first of these objectives was met by interrupting the air flow at a rate of one cycle per second. The amplifier was tuned to one cycle and did not respond to the d-c potential on the signal plate of the ion chamber. The second objective, that of maintaining the chamber load-resistance at not more than one megohm, could be achieved only by extracting ions from a sufficiently large amount of air. The ion chamber has a square cross section of 16 square feet.

The complete system was made up of an air scoop, and air duct, a shutter, a small-ion remover, a large-ion chamber, a one-cycle amplifier, a Brush a-c amplifier, a Brush recorder, a filter for the ion chamber potential, a chamber potential supply, and a 24 volt dc to 110-volt 60-cycle motor generator. The total weight was about 2500 pounds. The ion chamber, small-ion remover and shutter were installed just aft of the mechanic's panel with the air duct connected to the scoop in the forward bomb bay. Figures 2 through 6 show the installation on the K-85. Figure 2 is the air scoop under the blimp car. In Figure 3 the duct can be seen extending aft toward the shutter, small-ion remover, and chamber. Figure 4 shows a close up of the chamber, shutter and small-ion remover with the one cycle per second amplifier on top of the chamber. Figures 5 and 6 are views of the after part of the installation taken from the port and starboard sides of the ship respectively. In the metal box on the deck in Figure 6 is the filter for the ion chamber polarizing voltage. The ion chamber was constructed of aluminum plates separated alternately into two groups. One set of plates was polarized and the other set connected to a one-megohm load resistor. Each group of plates was separately supported on porcelain insulators attached to the grounded frame. A schematic diagram in Figure 7 shows the construction of the chamber and the electrical connections. The small-ion remover is of the same type of construction as the chamber, differing only in length and plate spacing. In operation, the air, forced into the scoop and duct by the forward motion of the ship, was interrupted by the shutter, was stripped of small ions by the small-ion remover and passed through the chamber and out the after end of the car. The charges collected in the chamber caused a current to flow in the one-megohm load resistor across which the signal voltage was developed. After amplification in the one-cycle amplifier the signal was recorded on paper.

The shakedown flights at Lakehurst showed a steady one cycle per second background out of phase with the exhaust frail signals. Consequently when air containing increased ion concentration passed through the chamber the signal at the recorder decreased. The background was due to a combination of unidentified causes. Figure 8 shows typical recordings taken in flight in a re-

UNCLASSIFIED
SECURITY INFORMATION

UNCLASSIFIED
SECURITY INFORMATION

UNCLASSIFIED

gion free of exhaust and in an exhaust trail 1 mile astern of a merchant ship. The small-ion remover was not used in flight since the one-cycle-per-second background obscured the action of the small-ion remover.

Figures 9 and 10 are plots of signal strength as a function of time in exhaust trails behind a merchant ship and a snorkeling submarine. These plots have been made by subtracting the one-cycle-per-second background from the exhaust trail records and considering the difference as that part of the signal which was due to the exhaust ions. Each of the plotted points is a ten-second average of the signal strength. Zero time was when the control car of the blimp was directly over the source of exhaust ions. In Figure 10 no points were plotted between zero time and 140 seconds. Between these points the signal due to exhaust ions was so strong as to be nearly equal to the one-cycle component of the background signal. The remainder consisted of higher harmonics which obscured the one cycle signal. It is safe, however, to say that the signal was at least 600 microvolts at all times between 0 and 140 seconds. The electronic background noise was slightly under 1 microvolt. During the exercises with the submarine, snow fell about 50 per cent of the time; the sea state was estimated at 3; and vertical stability of flight was difficult to maintain. Although detectable trails were found at all altitudes between 50 and 200 feet, no conclusions about the vertical distribution of ions were possible because of the strong air turbulence. No attempts were made to get trails at ranges greater than 4000 yards.

There were indications also that the wake caused by the ship's propeller was a source of ions. On occasions when ships were traveling broadside to a strong breeze which separated the exhaust trail and water wake, an increased ion concentration was noted at low altitudes close to the stern of the ship. Figure 11 is a recording showing how the ion concentration varied immediately astern of a merchant ship moving in the afore mentioned wind conditions.

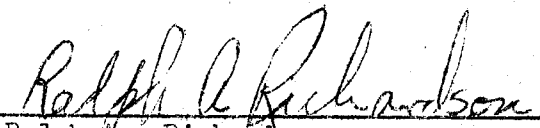
Ralph A. Richardson
Physicist

UNCLASSIFIED
SECURITY INFORMATION

UNCLASSIFIED

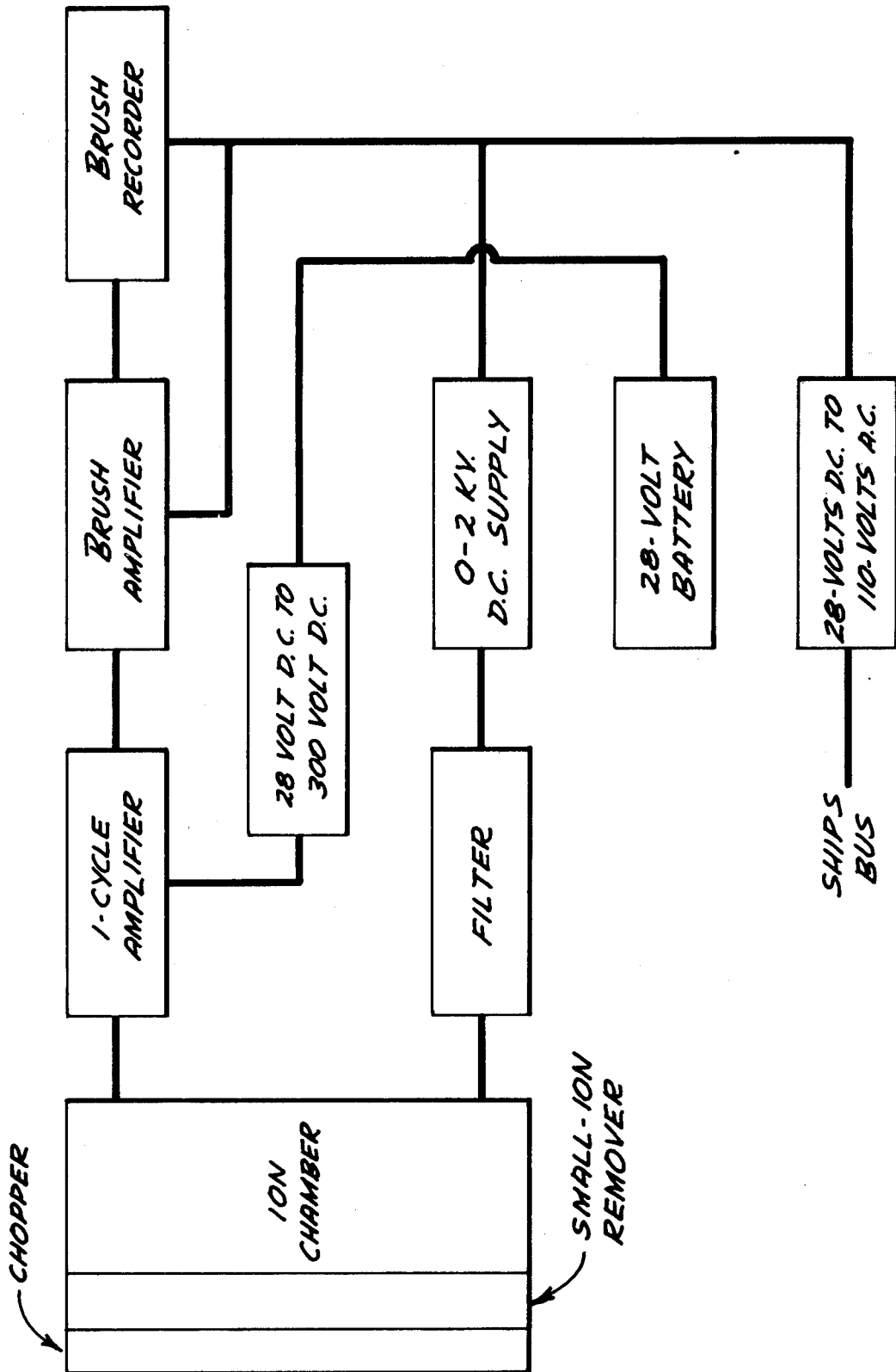

BLOCK DIAGRAM OF COMPLETE SYSTEM.

Fig. 1

UNCLASSIFIED

UNCLASSIFIED SECRET

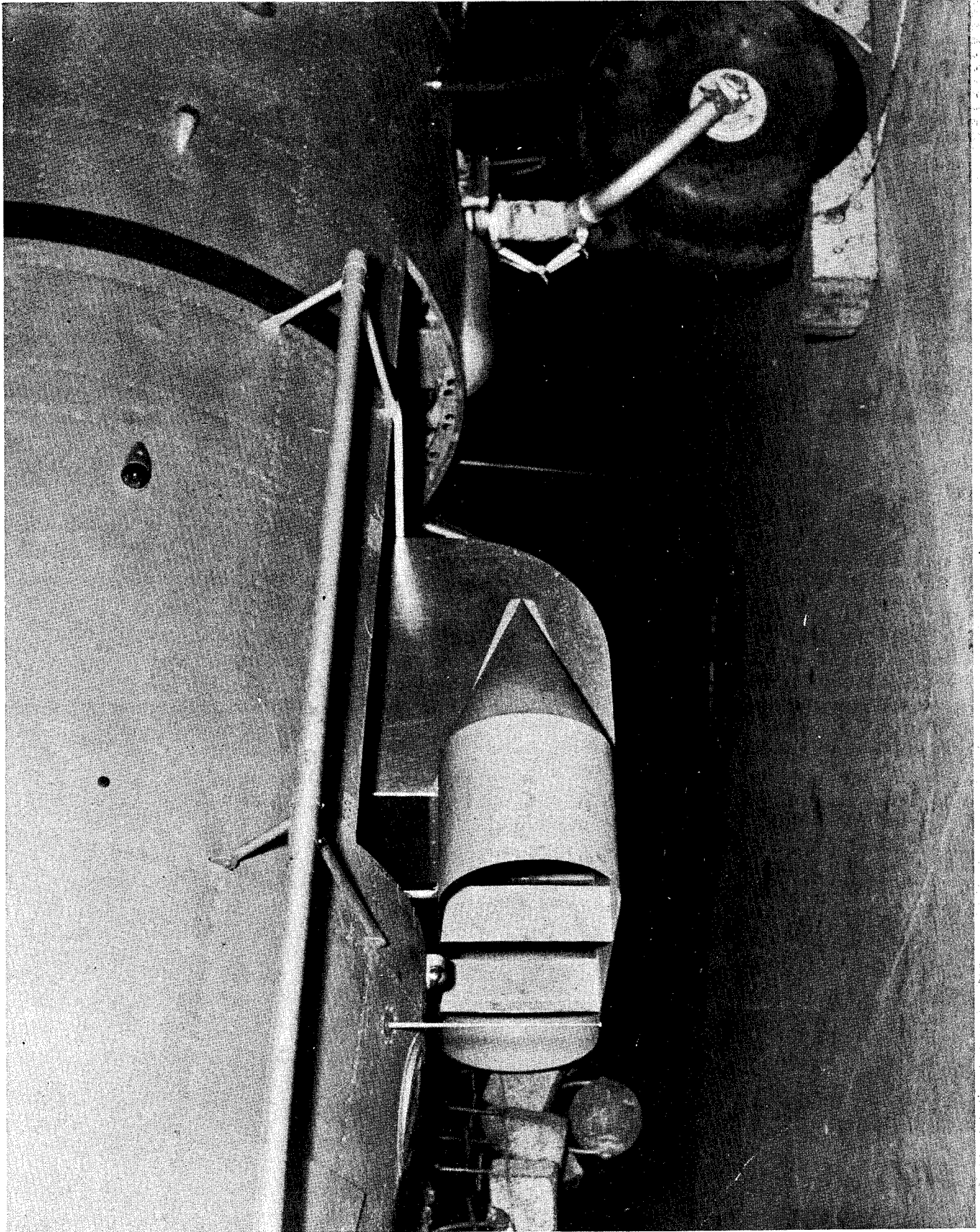

UNCLASSIFIED SECRET
ULTIMATE INFORMATION

Figure 2 - Air Scoop

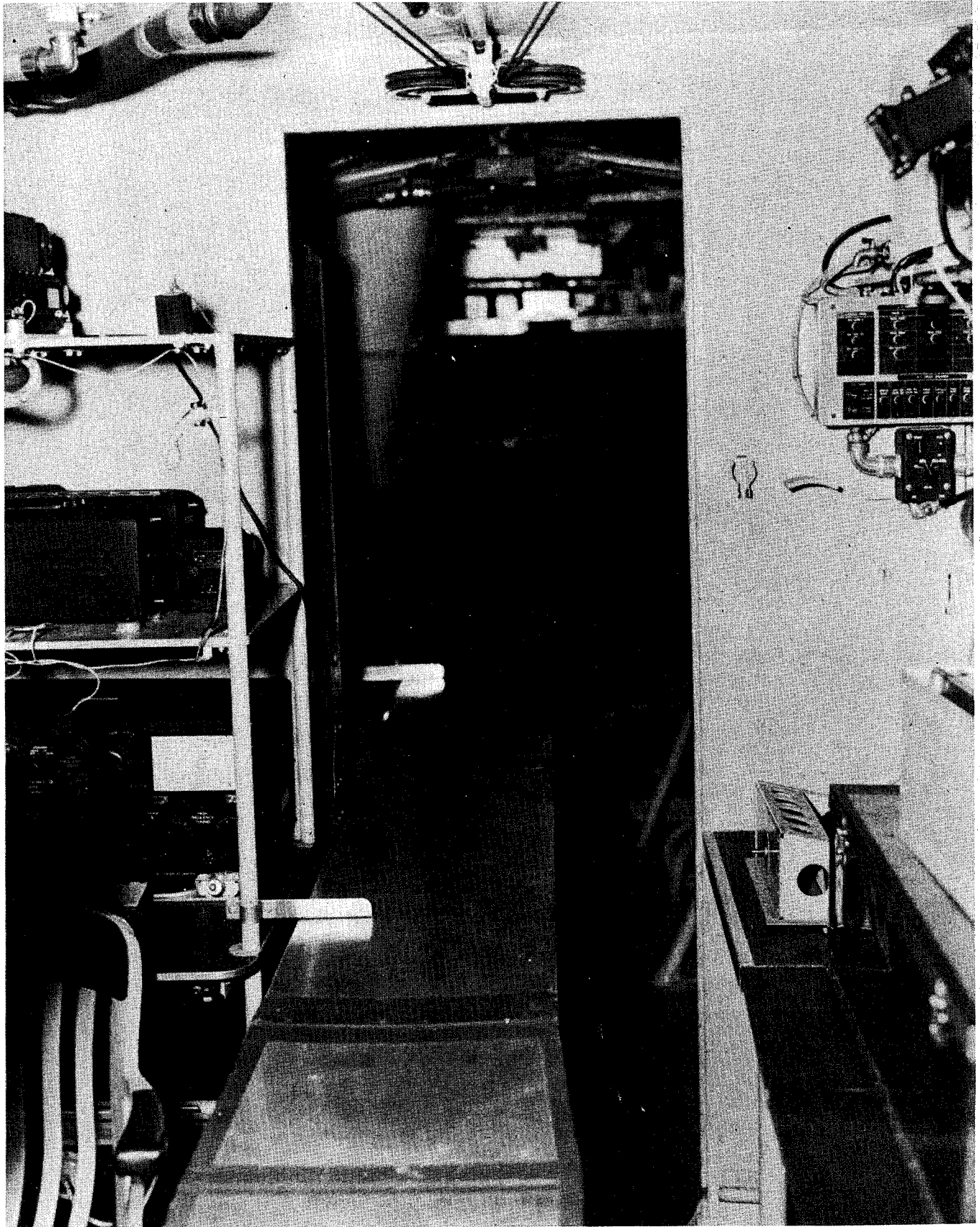

Figure 3 - Air Duct Looking Aft

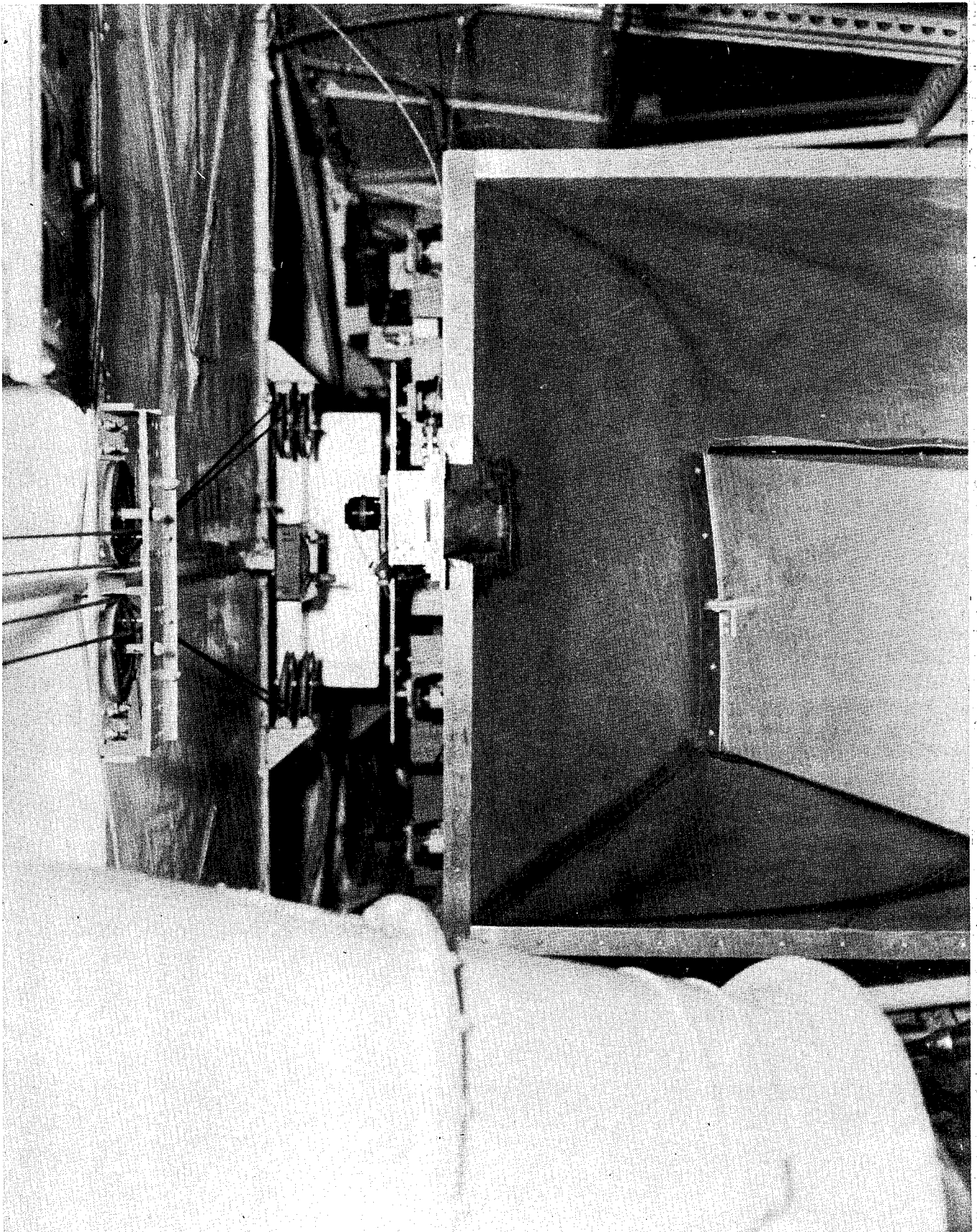
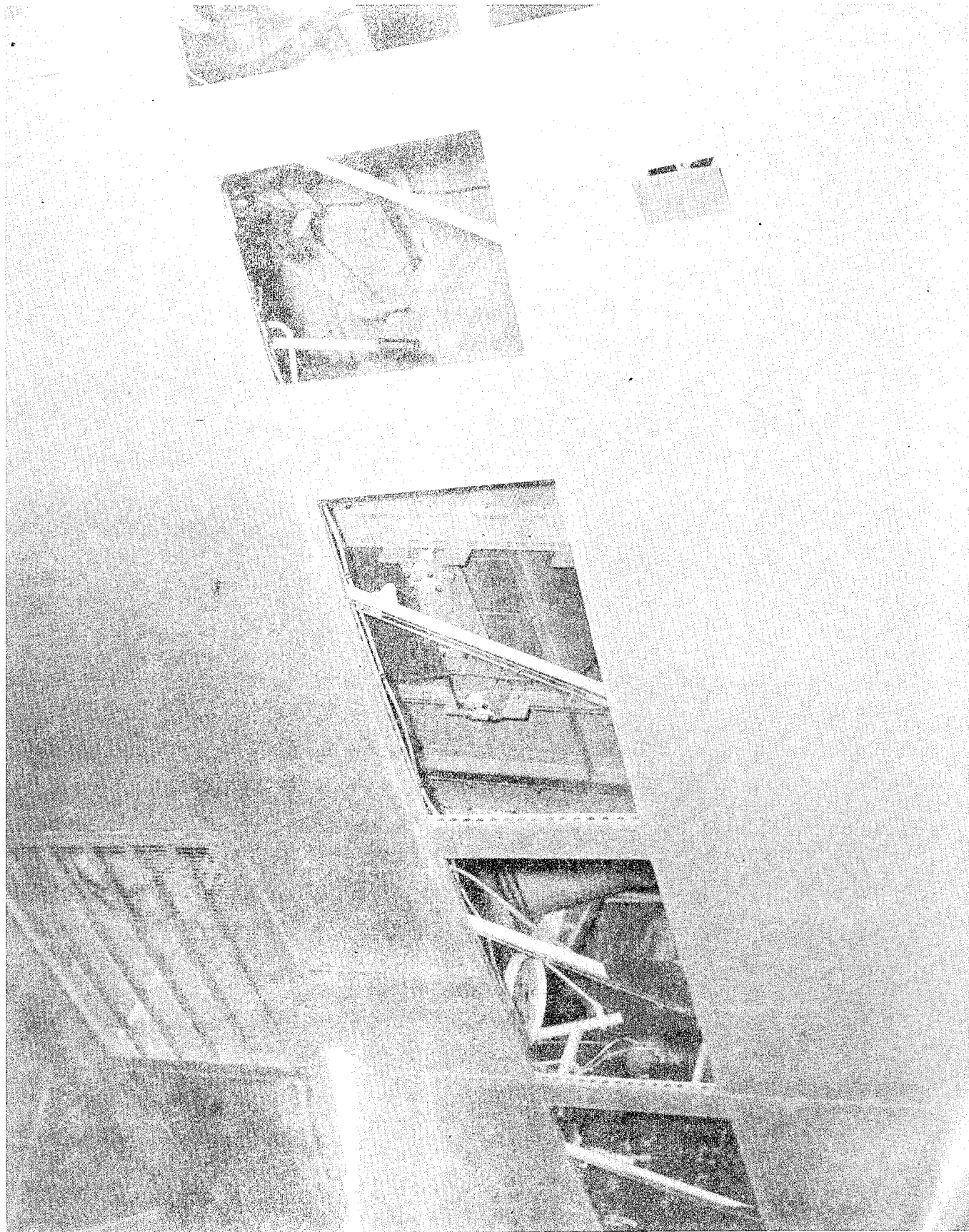

Figure 4 - Forward End of Ion Chamber



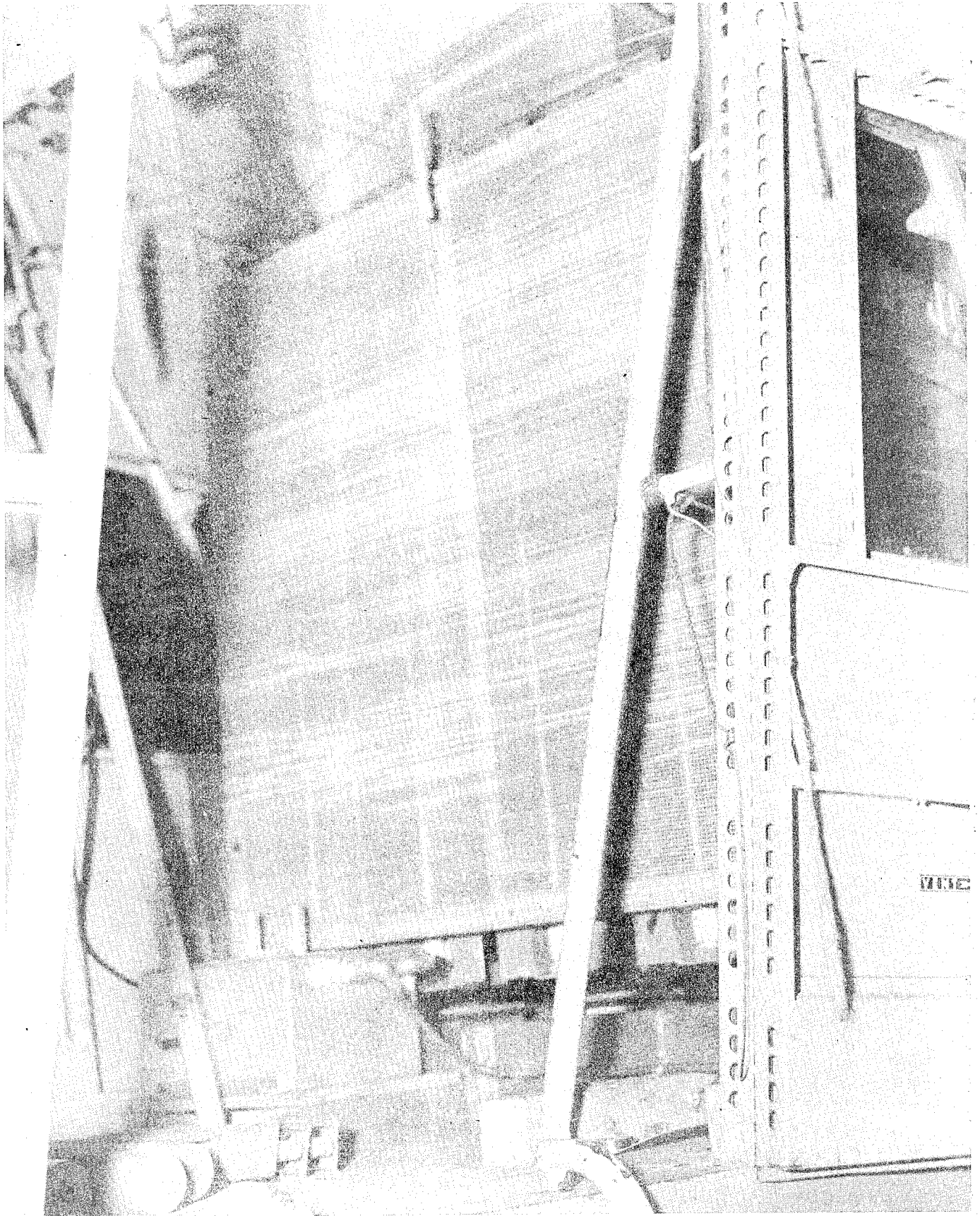
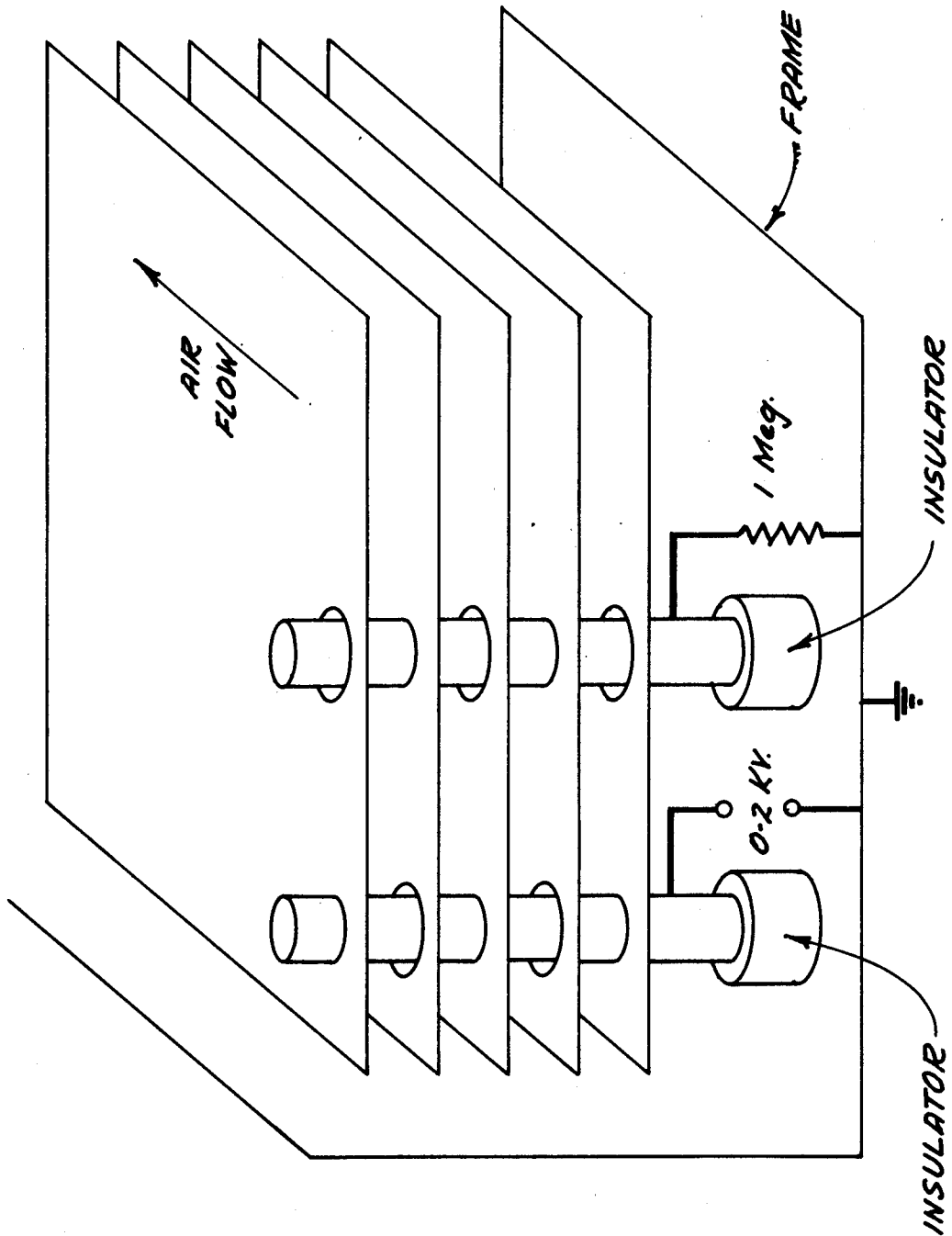

Figure 6 - Rear View Starboard Side

UNCLASSIFIED
SECRET



SCHEMATIC DIAGRAM OF ION CHAMBER.

UNCLASSIFIED
SECRET
SECURITY INFORMATION

Fig. 7

UNCLASSIFIED
SECRET

UNCLASSIFIED

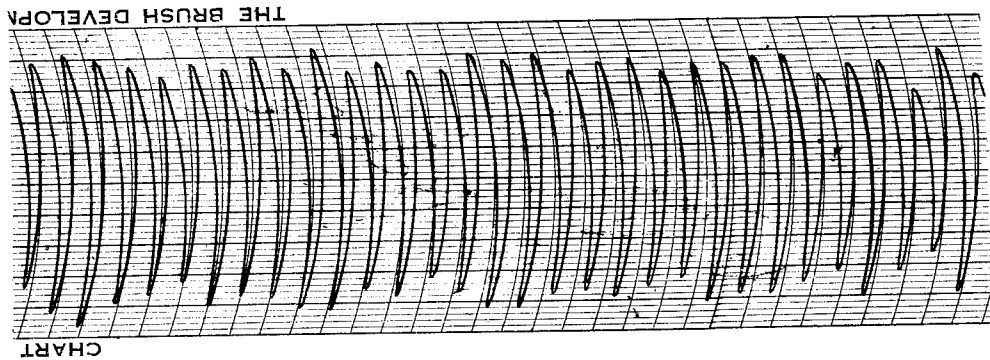

*BACKGROUND FREE OF EXHAUST CONTAMINANTS.
AVERAGE RMS SIGNAL 1100 μ VOLTS.*

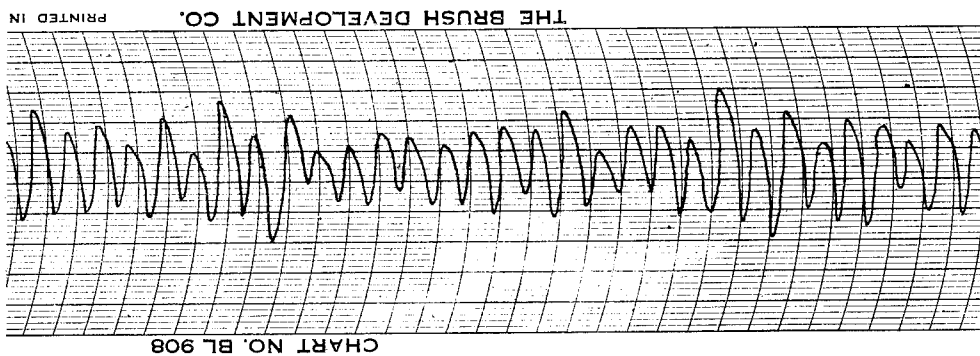

*SIGNAL OBSERVED 1-MILE FROM A MERCHANT SHIP.
AVERAGE RMS SIGNAL LEVEL 300 μ VOLTS.*

UNCLASSIFIED
SECRET
SECURITY INFORMATION

Fig. 8

~~SECRET~~
UNCLASSIFIED

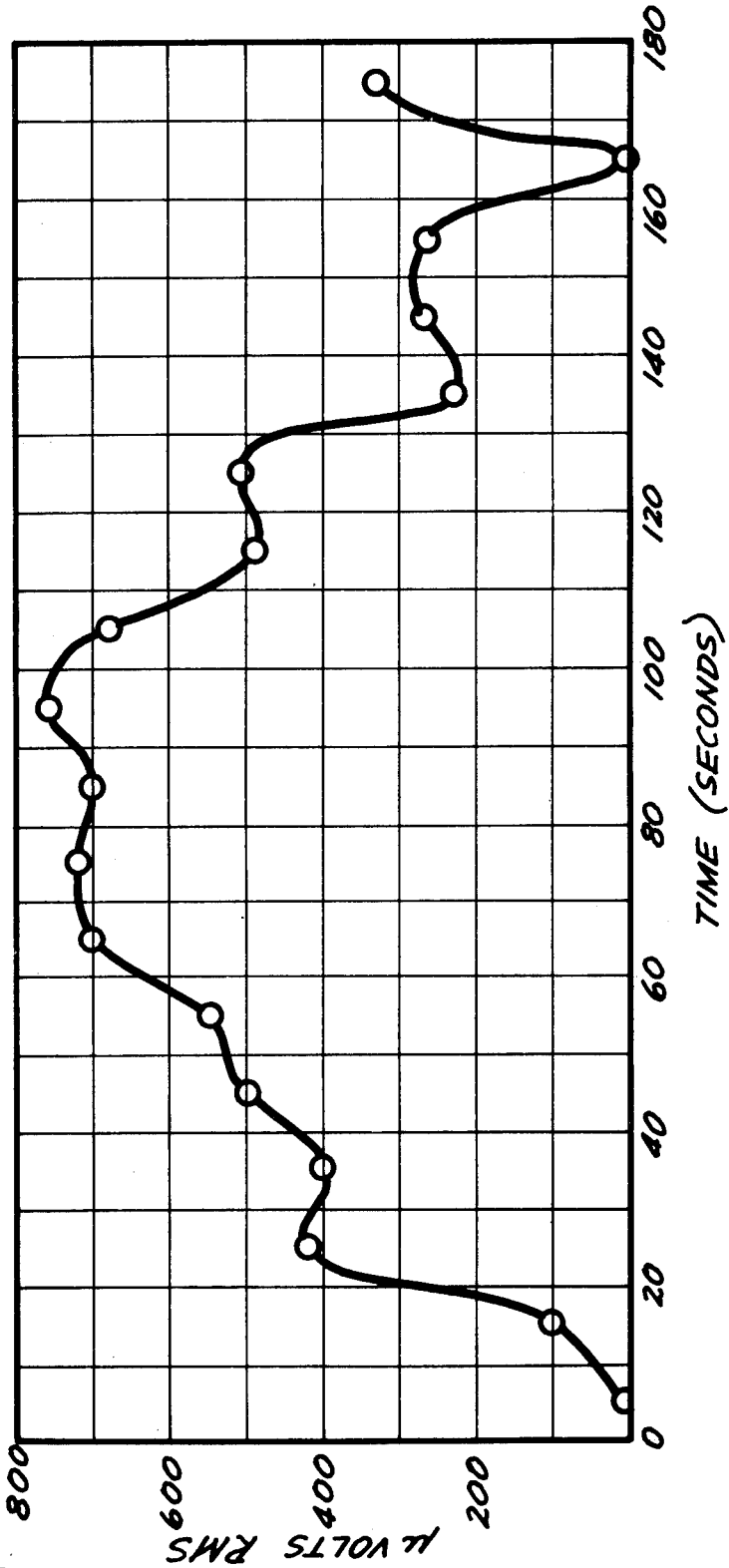

3-MINUTE TRAIL TAKEN AT 400-FT. ALTITUDE
5000-TON FREIGHTER 12-KNOTS

~~SECRET~~
UNCLASSIFIED
SECURITY INFORMATION

Fig. 9

~~SECRET~~
UNCLASSIFIED

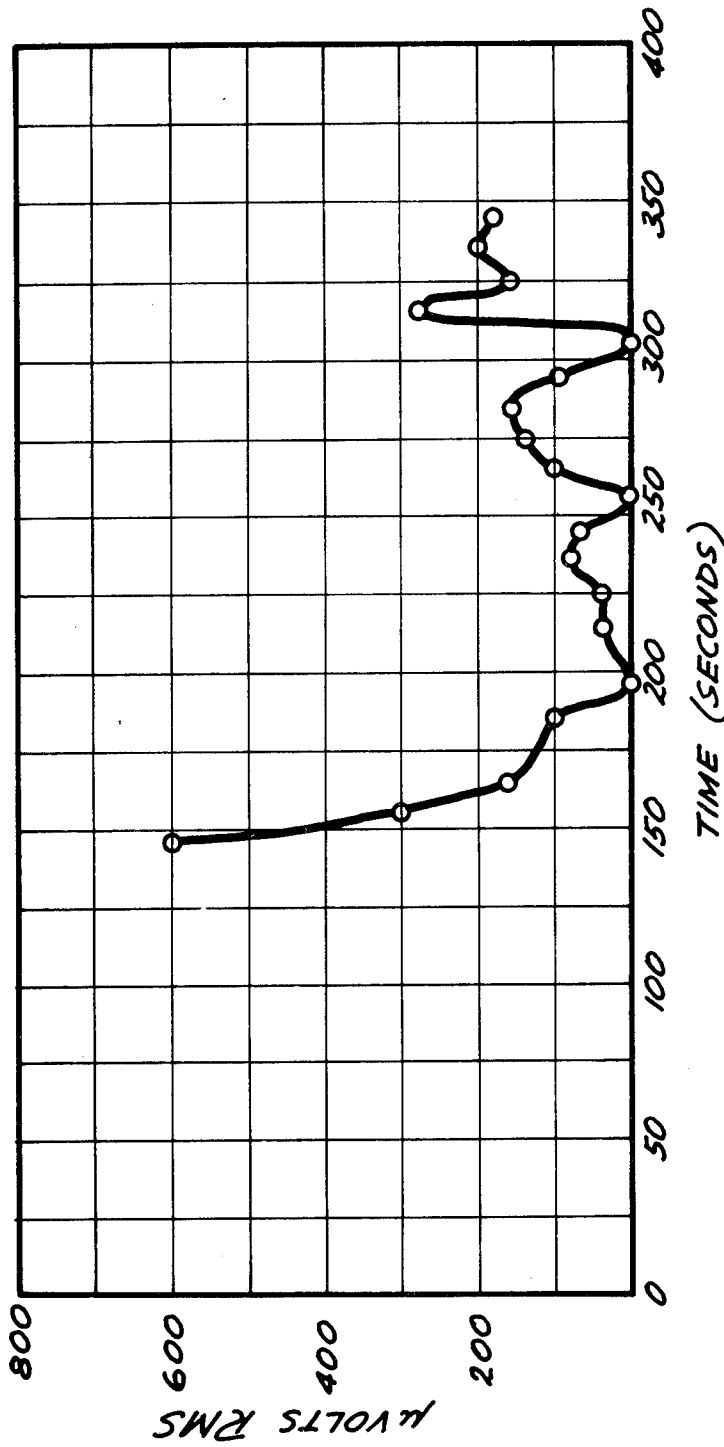

SUBMARINE SNORKELING AT 5 KNOTS.

~~SECRET~~
UNCLASSIFIED
SECURITY INFORMATION

Fig. 10

UNCLASSIFIED
~~SECRET~~

UNCLASSIFIED

CHART NO. BL 908

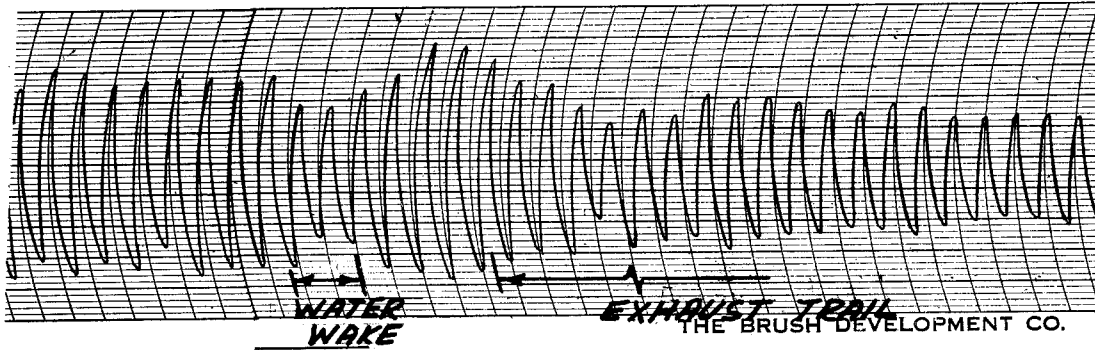

*VARIATION IN ION CONCENTRATION ASTERN
OF A SHIP IN A BROADSIDE BREEZE.*

UNCLASSIFIED
~~SECRET~~
SECURITY INFORMATION

Fig. 11