

**OFFICE OF NAVAL RESEARCH**

***END-OF-THE-YEAR REPORT***

***PUBLICATIONS/PATENTS/PRESENTATIONS/HONORS/STUDENTS REPORT***

for

**GRANT: N00014-90-J-1148**

R & T Code 4132016

***Design, Synthesis and Characterization  
of Novel Nonlinear Optical Polymers***

Dr. Sukant Tripathy  
University of Massachusetts Lowell  
Department of Chemistry  
1 University Avenue  
Lowell, Massachusetts 01854

May 31, 1996

**DTIC QUALITY INSPECTED 3**

Reproduction in whole, or in part, is permitted for any purpose of the United States Government. This document has been approved for public release and sale: its distribution is unlimited.

19960729 127

**OFFICE OF NAVAL RESEARCH**  
**PUBLICATIONS/PATENTS/PRESENTATIONS/HONORS REPORT**

R & T : 4132016

GRANT Number: **N00014-90-J-1148**

GRANT Title: **Design, Synthesis and Characterization of Novel Nonlinear Optical Polymers**

Principal Investigator: Dr. Sukant Tripathy

Mailing Address: University of Massachusetts Lowell  
Department of Chemistry  
1 University Avenue  
Lowell, Massachusetts 01854

Phone Number: (508) 934-3687 Fax Number: (508) 458-9571

E-mail Address: tripathys@woods.uml.edu

***PART I***

- a. Papers submitted to refereed journals, but not published: **4**
- b. Papers published in refereed Journals (list attached): **11**
- c. Book chapters submitted, but not yet published: **1**
- d. Book chapters published: (list attached):**2**
- e. Printed technical reports & non-refereed papers (list attached): **2**
- f. Patents filed: **3**
- g. Patents granted (list attached):**1**
- h. Invited presentations (list attached): **6**
- i. Submitted presentations (list attached): **8**
- j. Honors/Awards/Prizes for contract/grant employees (list attached): **1**

k. Total number of full-time equivalent graduate students and post-doctoral associates supported during this period, under this R&T project number:

Graduate Students: 1

Post Doctoral Associates: 2

including the number of,

Female Graduate Students: 0

Female Post Doctoral Associates: 1

the number of,

Minority Graduate Students: 0

Minority Post Doctoral Associates: 0

and the number of,

Asian Graduate Students: 1

Asian Post-Doctoral Associates: 2

Other funding (List agency, grant title, amount received this year, total amount, and the period of performance, and briefly state the relationship of that research to your ONR grant):

The research listed below is not related to the reported ONR grant.

Spire Corporation, "*Polymeric Materials for Second Harmonic Generations*" Research Grant, August 11, 1993 - April 15, 1995 - \$60,000.00.

Army Research Office, "Novel Bio-process for Polymer Synthesis Assembly of New Materials", Research Grant, September 26, 1994 to September 25, 1996, \$192,480.00

National Science Foundation, "*Interpenetrating Network Second Order Nonlinear Optical Polymers*" Research Grant, March 1, 1994 to February 28, 1997, \$240,000.00.

## *PART II*

- a. Principal Investigator: Dr. Sukant Tripathy
- b. Current telephone number: 508-458-7116
- c. Cognizant ONR Scientific Officer: Dr. Kenneth J. Wynne
- d. Program objective

The principal focus of the project is to research and develop new polymeric materials based on molecular level design and solid state chemistry. The goals have been to develop electroactive polymers with novel electronic, optical and nonlinear optical properties.

- e. Significant results during last year:
  - 1. A new process of direct formation of surface relief gratings has been invented and further investigated. Large amplitude surface gratings ( $>3000\text{\AA}$ ) have been optically obtained on polymer films containing azobenzene chromophores. We confirmed that this is not a thermal effect. This convenient optical fabrication of surface gratings on polymer films opens new ways for various optical elements and devices.
  - 2. A novel soluble mainchain azobenzene conjugated polymer was prepared. This is the first report of a high molecular weight (MW = 10,500 a.u), soluble, conjugated main-chain azo polymer. The polymer is soluble in water over a wide range of pH. It is also soluble in polar organic solvents such as methanol, DMF, DMSO etc. The polymer exhibits strong fluorescence in solution. Self-assembled multilayers of this azo polymer have been fabricated.
- f. Brief summary of plans for next years work:

### *Molecular System Design and Synthesis :*

*New Polymers for Surface Relief Gratings:* Photoinduced orientation and surface grating formation of azobenzene containing polymers have been studied in the side chain polymers so far. Photo-induced effects of azo groups in the backbone will affect the mobility of the polymer chains dramatically. Polymers with azo groups in the backbone will be synthesized. Surface grating formation and other optically induced

processes will be investigated. Synthetic scheme of the main chain azobenzene polymers is shown in Scheme 1.

*Design of Novel Water Soluble Azo Polymers:* Extended backbone conjugation in a polymer is not necessarily a critical requirement for many electronic and photonic applications. Incorporation of both conjugated azo oligomer units and flexible spacer in the backbone will provide desired properties and processability. Bifunctional oligomers containing azo group in the main-chain and sulfonic acid groups along the main-chain will be designed and synthesized. Synthetic schemes for the various oligo- and high polymers are described in Scheme 2 and 3.

*Processing and fabrication:* In most cases, polymer films will be prepared by spin-coating or casting from the solution onto various substrates such as glass, silicon, and ITO glass. For surface grating study, an interferometric apparatus will be employed. The intensity, polarization, and wavelength of the writing laser beams will be varied. Multiple gratings with different geometry can be superimposed on the same spot. Gratings will be formed at various temperatures from below room temperature to near T<sub>g</sub>.

As a new approach to an alignment layer for LC molecules we will utilize tailore optically written surface undulations. LC cells with alignment layer containing azo groups will be prepared. Photo-fabricated surface grating on the alignment layer will be employed to align LC molecules.

For ultrathin film multilayer fabrication, aqueous polymer solutions over a wide range of pH will be prepared. The water soluble azo polymers will be assembled in to multilayers through ionic interactions. Alternate dipping of hydrophilized glass slide in a polycation solution at acidic pH, followed by dipping in the azo polymer solution leads to multilayer formation. The multilayer fabrication will be achieved on ITO slides as well. A number of polycations are available for the appropriate design.

*Characterization:* A number of solid state characterization techniques are being employed in our laboratories. NMR, FT-IR, Raman, and UV-Vis-NIR spectroscopies will be utilized to identify and investigate the chemical structures of the synthesized molecules. Thermal analysis techniques such as DSC, and TGA will be employed to study thermal properties of the polymers. Various polarized spectroscopies will be used for study of inherent or optically induced orientation of the polymer molecules in the solid state. Linear and nonlinear optical properties will be investigated

using various lasers, optical elements, and detectors. Photoluminescence and electroluminescence behaviour will be investigated. Dark and photoconductivity will be measured. Atomic force microscopy and electron microscopy will be employed for the surface characterization.

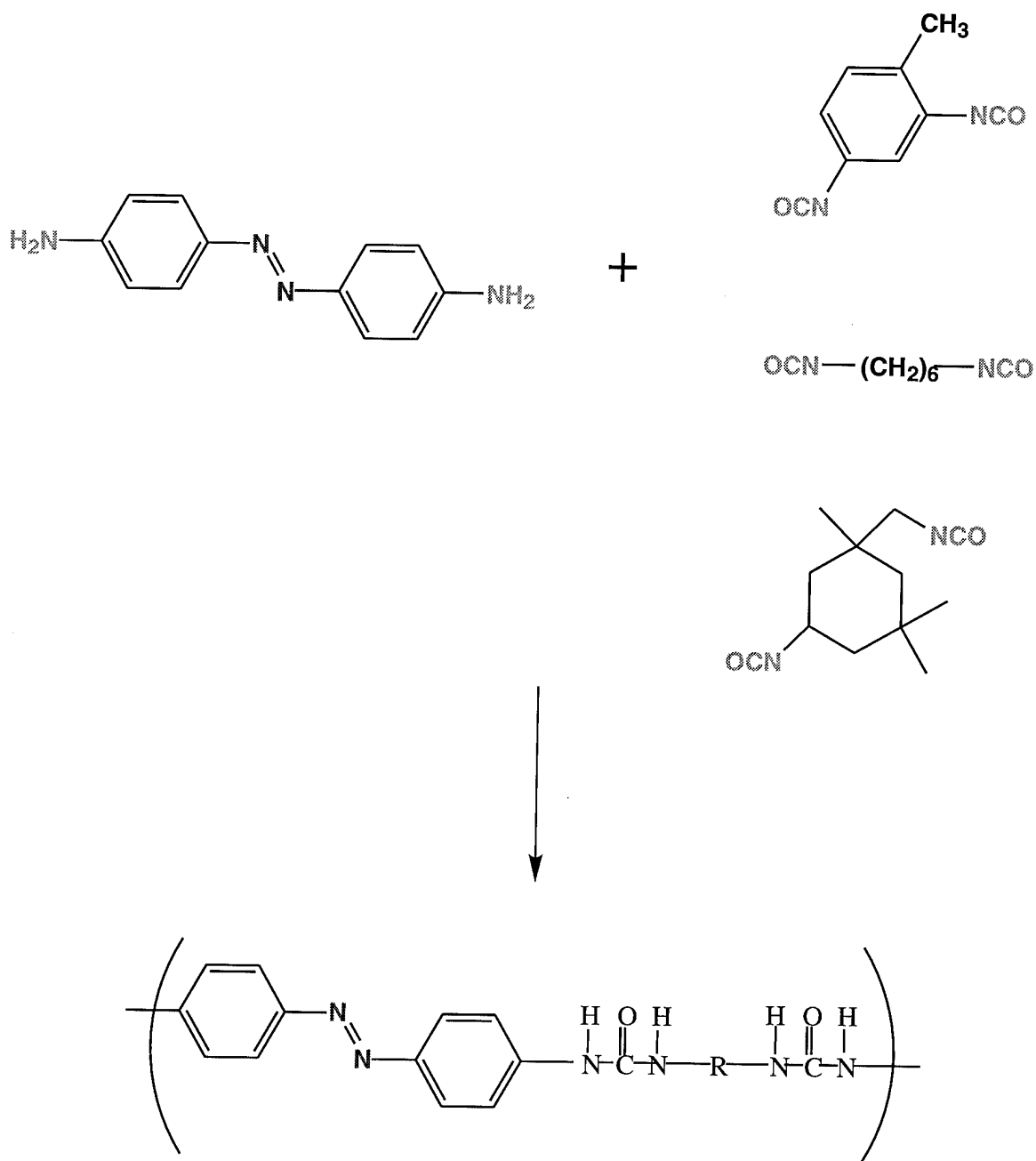

Scheme 1. Proposed synthesis of azobenzene polyureas with various linking units.

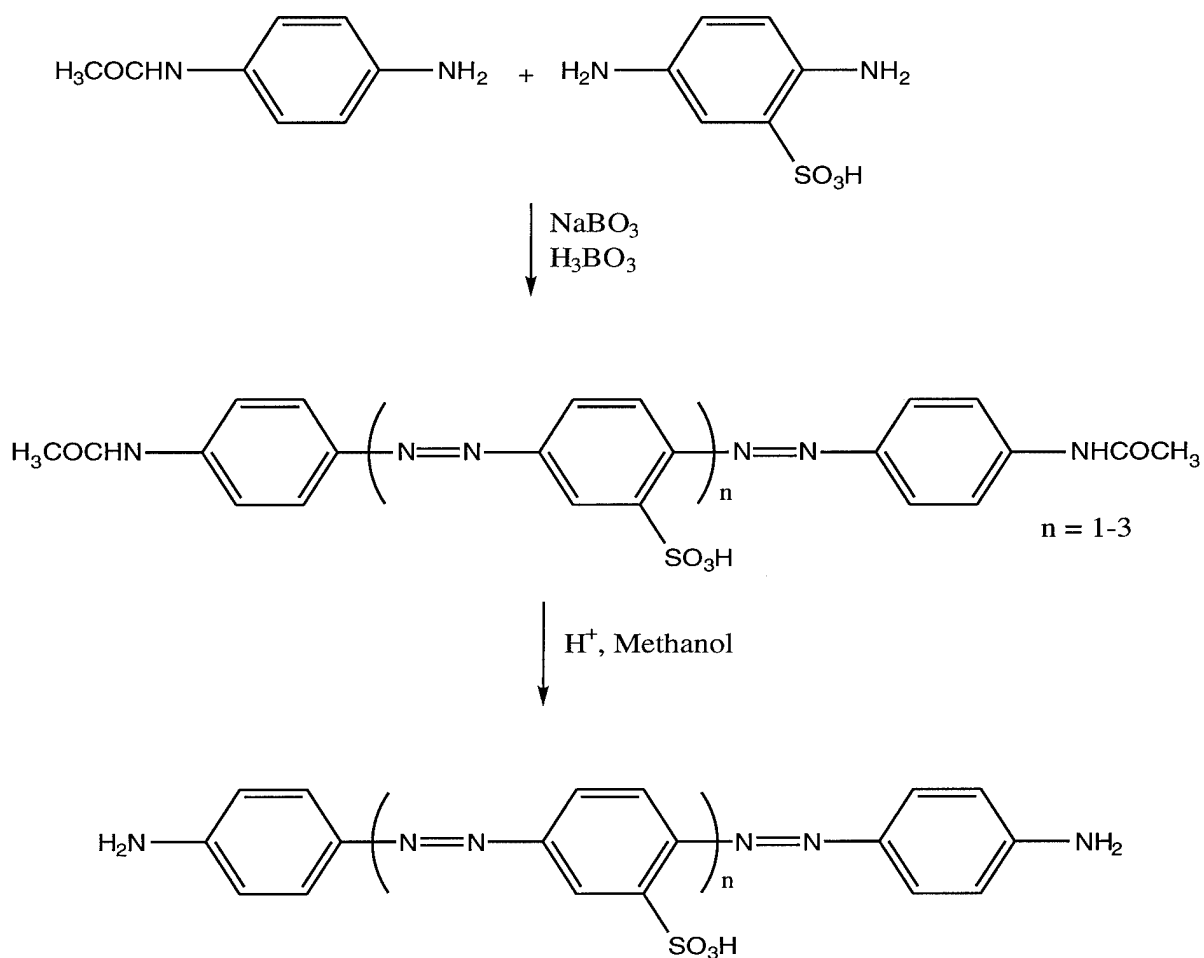

Scheme 2. Proposed synthesis of difunctional oligo-azobenzenes.

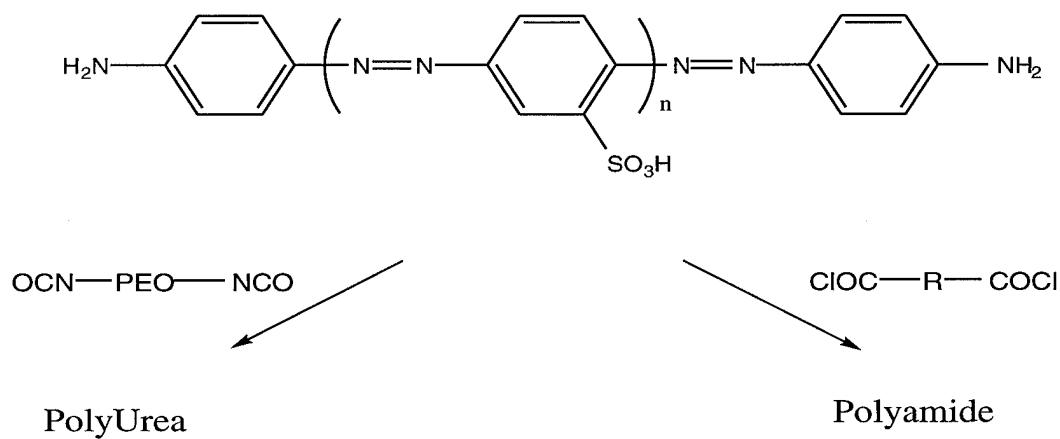

Scheme 3. Proposed polymerization of azo-oligomers and spacer groups.

- g. Name of graduate students and post-doctorals currently working on the project.

Post-doctoral Fellows

Dr. Woohong Kim  
Dr. Lian Li  
Dr. Sutiyaoy Marturunkakul  
Dr. Jeng-I Chen  
Dr. Xiaogong Wang  
Dr. Taekseung Lee  
Dr. Dong-Kyu Park

Graduate Students (Ph.D Candidates)

Mr. Govindasamy Chittibabu  
Mr. Dong-Yu Kim  
Mr. Xinli Jiang  
Mr. Dong-Wook Cheong  
Mr. H. C. Wang  
Mr. Srinivasan Balasubramanian  
Mr. Jae-Yung Kim

Department

Chemistry  
Chemistry  
Physics  
Chemistry  
Chemistry  
Chemistry  
Chemistry

Undergraduate Students

Mr. John Patronick

Department

Chemistry

***PART III***

***Research Highlights***

**ACCOMPLISHMENT: Photodriven large scale motion of polymers**

- Objective: To investigate reversible photoinduced surface relief grating formation on azobenzene-based polymer films
- Challenge: Fundamental understanding and diverse application of this newly invented process
- Approach: Investigation of the surface relief grating writing process with variation in the molecular architecture and other design parameters
- Progress:
  - \* Polymers containing azobenzenes are prepared
  - \* Large amplitude surface gratings are fabricated
  - \* This new process was clearly established as not a thermal process
  - \* Photo-isomerization of Azobenzenes is critical
- Impact: Validation of a new optically induced phenomenon in solid polymer

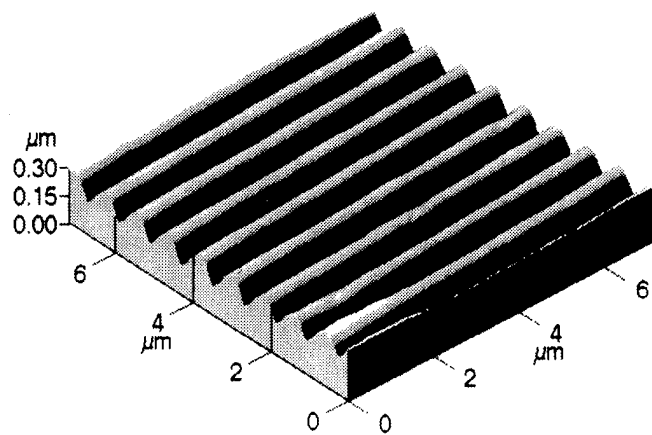

**AFM 3-D view of the surface relief gratings**

## Chemical structures of polymers with various side chains

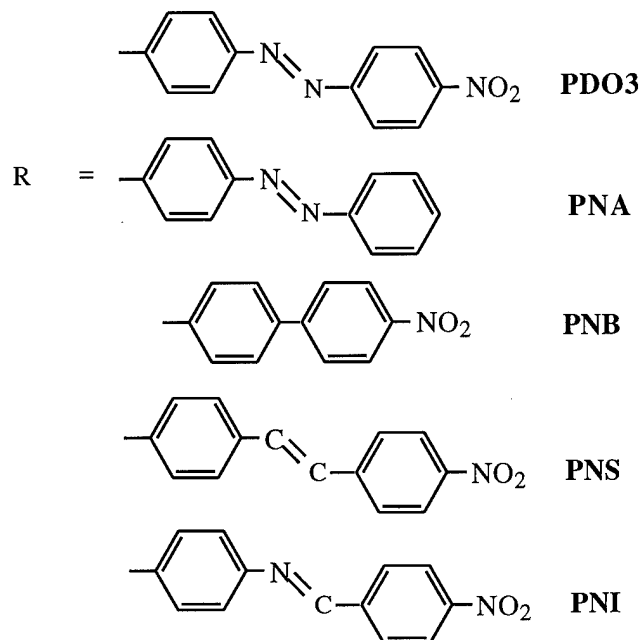
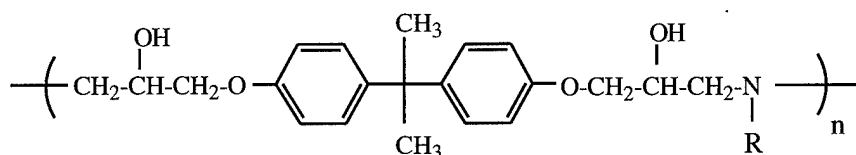

- Only azobenzene based polymers PDO3 and PNA showed large amplitude surface relief gratings ( $> 3000 \text{ \AA}$ ).

## Experimental Setup for Grating Formation

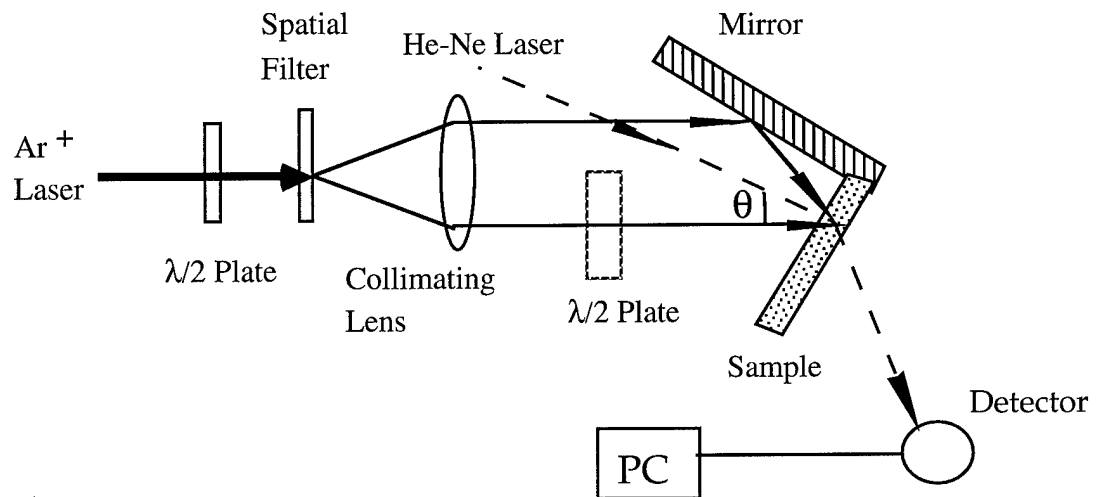

AFM 3-D view of two gratings written orthogonally to each other

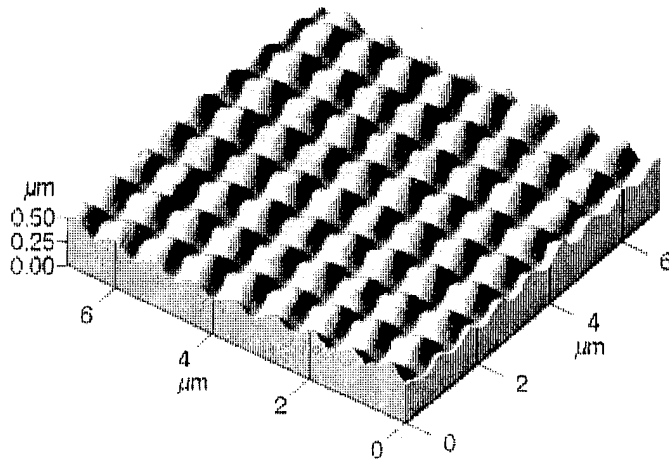

AFM 3-D view of the dual gratings sequentially written with 488 and 514 nm beams from Ar<sup>+</sup> laser

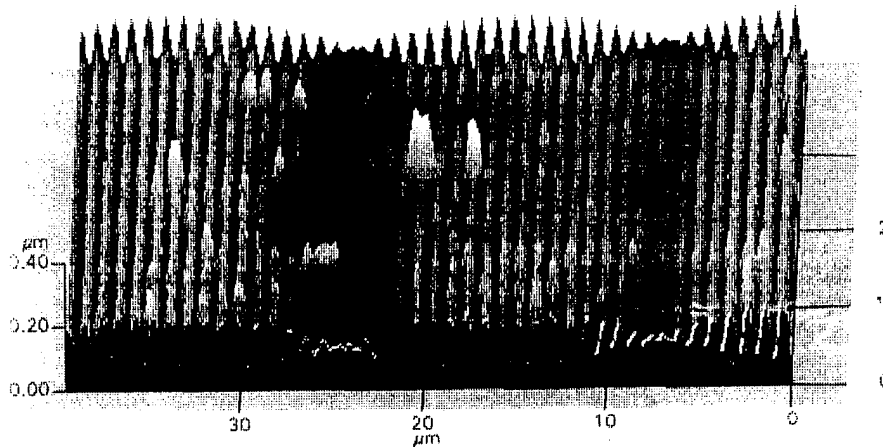

## AFM surface profile of the pattern on a PDO3 film produced by edge diffraction

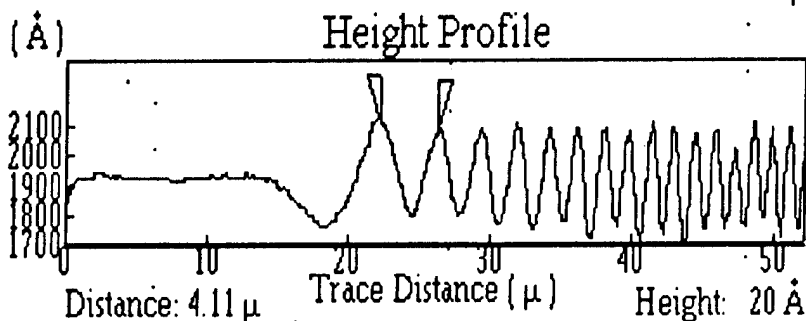

Theoretical intensity pattern (----) and negative first derivative (—) of the intensity of the laser beam diffracted from a straight sharp edge

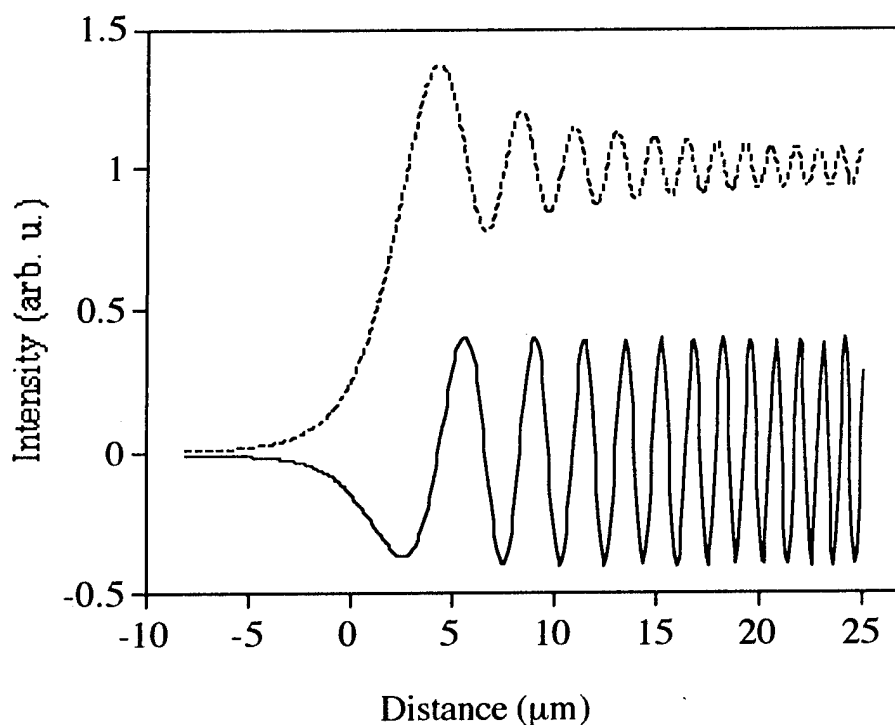

- The surface pattern from straight edge diffraction mimics the negative first derivative of the intensity distribution.

## Summary

- Erasable surface relief gratings with large amplitude could be directly produced on polymer films upon exposure to an interference pattern of visible laser beams.
- The gratings were stable below  $T_g$  of the polymer and could be erased by heating above  $T_g$  or by optical exposure.
- Multiple gratings can be superimposed on the same spot.
- Chromophores which can undergo trans-cis-trans photoisomerization such as an azo dye give rise to large surface change.
- The amplitude of the surface relief grating is very strongly dependent on the polarization of the recording beams.
- Thermal effects due to light absorption do not play an appreciable role in recording at the intensities used.
- The surface pattern from straight edge diffraction mimics the negative first derivative of the intensity distribution.

## ACCOMPLISHMENT: Novel soluble conjugated azo polymers

- Objective: To develop novel soluble conjugated main-chain azo polymers for photonics applications
- Challenge: Pervious attempts to synthesize main-chain conjugated azo polymers have resulted in mostly insoluble and intractable oligomers
- Approach: The presence of sulfonic acid groups makes the monomer and the polymer water soluble
- Progress :
  - \* High molecular weight (MW = 10,500 a.u), soluble, conjugated main-chain azo polymers are prepared.
  - \* The polymer is soluble in water over a wide range of pH, and, in polar organic solvents.
  - \* The polymer exhibits strong fluorescence in solution.
  - \* Self-assembled multilayers were fabricated.
- Impact: Potential for polymer thin films in optical recording, memory, and switching applications

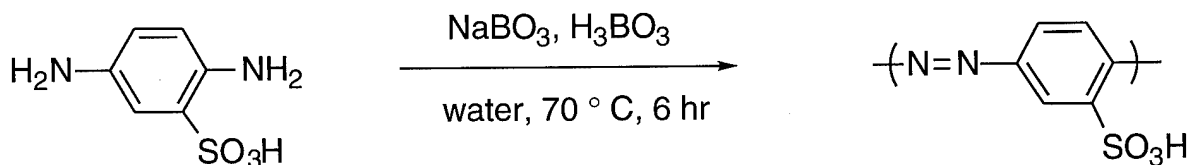

## UV-Vis spectrum of DABSA monomer and polymer in aqueous solution

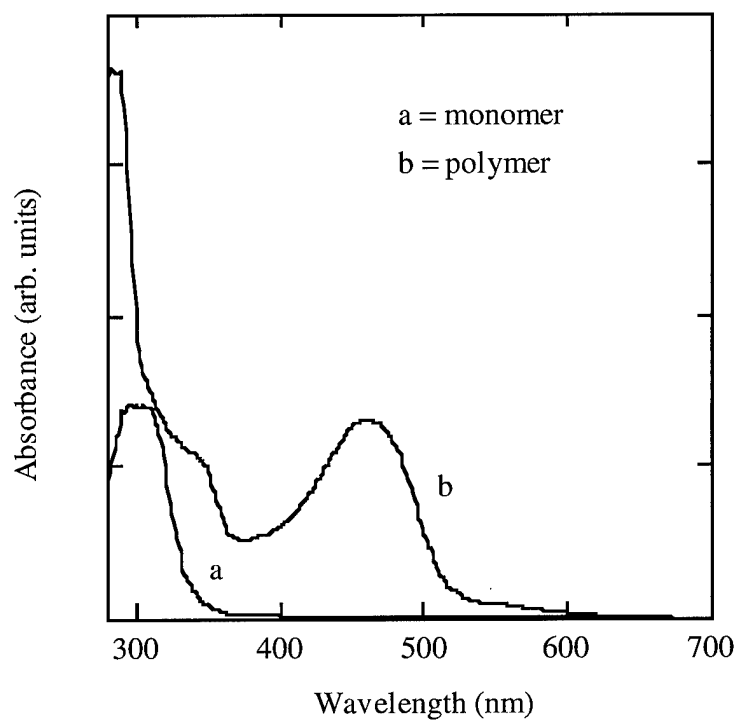

- The polymer solution exhibits strong fluorescence.

## Fabrication of self-assembled multilayers

- Alternate dipping of a hydrophilized glass or ITO slide in the polycation solution at pH = 2.5, followed by dipping in the azo polymer solution at the same pH leads to multilayer formation.
- The polycation in this study was poly(allylamine) hydrochloride.
- UV-vis spectrum of multilayer formation on ITO slide.

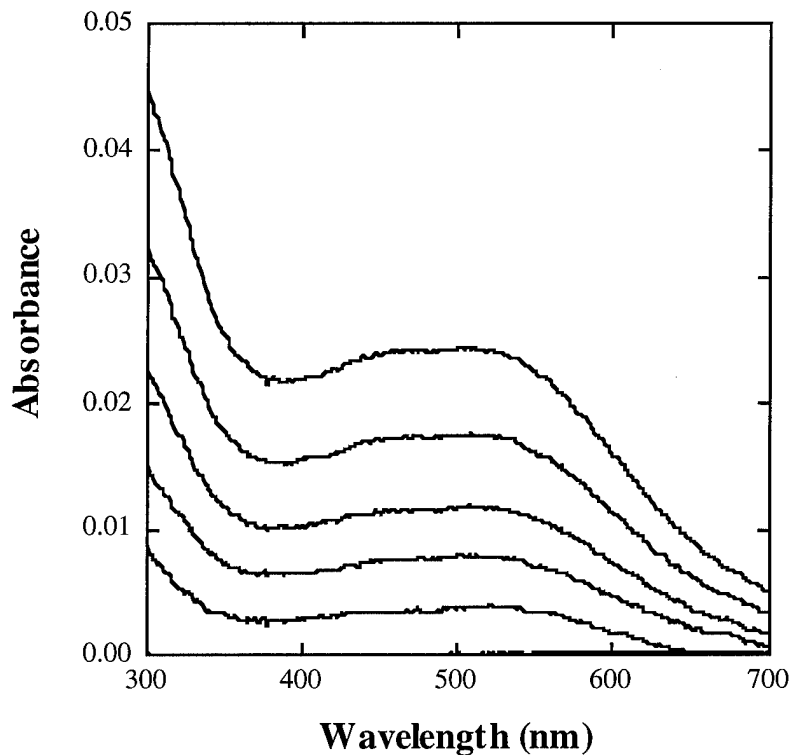

- The UV-vis spectrum shows the progressive linear increase in the absorption with increase in the bilayers on an ITO slide.
- The process can be extended to deposit several layers and the films thus formed can be studied for luminescence.

## Summary:

- This is the first report of a high molecular weight (MW = 10,500 a.u), soluble, conjugated main-chain azo polymer.
- The polymer is soluble in water over a wide range of pH. It is also soluble in polar organic solvents such as methanol, DMF, DMSO etc.
- The polymer exhibits strong fluorescence in solution. The presence of sulfonic acid group can be exploited in the fabrication of multilayer structures for potential electroluminescence studies.
- Self-assembled multilayers fabrication through ionic interactions has been performed.

## Attachment Page 1

### **b. Published Papers in Referred Journals 11**

1. "Photorefractive Effect in a Conjugated Polymer Based Material" (L. Li, K.G. Chittibabu, Z/ Chen, J.I. Chen, S. Marturunkakul, J. Kumar, S.K. Tripathy) *Optics Communications*, 125, pp. 257-261 (1996).
2. "Polarization Dependent Recordings of Surface Relief Gratings on Azobenzene Containing Polymer Films" (X.L. Jiang, L. Li, J. Kumar, D.Y. Kim, V. Shivshankar, S.K. Tripathy) *Applied Physics Letters*, Vol. 68 19 pp.2618-2620 (1996).
3. "Self Assembled Bulk Polydiacetylenes for Nonlinear Optics", (S. Tripathy, W.H. Kim, C. Masse, X.L. Jiang, J. Kumar), *Nonlinear Optics*, Vol. 15, pp. 111-118 (1996).
4. "Design and Synthesis of Interpenetrating Polymer Networks for Second-Order Nonlinear Optics", (S. Marturunkakul, J. I. Chen, L. Li, J. Kumar, S. K. Tripathy), *Polymers for Advanced Technologies*, Vol 7 pp 1-6 (1996).
5. "Oriented Z-Type Langmuir-Blodgett Films from a Soluble Asymmetrically Substituted Polydiacetylene" (D. W. Cheong, W. H. Kim, L. A. Samuelson, J. Kumar, S. K. Tripathy) *Macromolecules* 29 (5) 1416 - 1421 (1996).
6. "The Chromic Phase Transition in Hydrogen Bonded Polydiacetylenes" (V. Shivshankar, C. Sung, S.K.Tripathy, J. Kumar and D.J. Sandman) *Mol. Cryst. Liq. Crystals.*, 277, pp 323-330 (1996).
7. "Self-Assembled Spin-Coated and Bulk Films of a Novel Poly(diacetylene) as Second-Order Nonlinear Optical Polymers" (W.H. Kim, B. Bihari, R. Moody, N.B. Kodali, J. Kumar, S.K. Tripathy) *Macromolecules* 28 (2) 642-647 (1995).
8. "Polarized Laser Induced Holographic Surface Relief Gratings on Polymer Films" (D.Y. Kim, L. Li, X,L, Jiang, V. Shivshankar, J. Kumar, S.K. Tripathy) *Macromolecules* 28 8835-8839 (1995).
9. "Photoconduction in a polydiacetylene film" (T. Ravindran, W.H. Kim, A.K. Jain, J. Kumar, S.K. Tripathy) *J. Phys.: Condensed Matter*, 7, 1315-1325, (1995).
10. "Design of New Polydiacetylenes as Self Assembling Second Order Nonlinear Optical Polymers" (W.H. Kim, X.L. Jiang, J. Kumar, S.K. Tripathy), *Journal of Pure and Applied Chemistry*, Vol. 67 12 pp. 2023-2030 (1995).
11. "Novel Unsymmetrical Polydiacetylenes as Materials for Second and Third Order Nonlinear Optics", (C. E. Masse, K. Vander Wiede, W. H. Kim, X. L. Jiang, J. Kumar, S. K. Tripathy), *Chemistry of Materials*, 7 904-908 (1995).

Attachment page 2

**d. Book Chapters Published: 2**

1. "Investigation of Thermochromic Polydiacetylenes using Atomic Force Microscopy" (V. Shivshankar, D.J. Sandman, J. Kumar, S.K. Tripathy and C. Sung) Microscopy and Microanalysis 1995, ( G.W. Bailey, M.H. Ellisman, R.A. Hennigar and N. J. Zaluzec, Editors) Jones and Begell Publishing, NY p.490 (1995).
2. "Azobenzene Side Chain Polymer Films for Optically Induced Holographic Surface Relief Gratings"( D.Y. Kim, L. Li, J. Kumar, S. K. Tripathy) Optical Society of America, Technical Digest Series Vol. 21, *Organic Thin Films for Photonics Applications*, pp 361-364 (1995).

Attachment page 3

**e. Printed Technical Reports/Nonrefereed Papers 2**

1. "Characterization of Ultra thin Nonlinear Optical Films of an Asymmetric Polydiacetylene" (D.W. Cheong, V. Shivshankar, H.C. Wang, C. Sung, J. Kumar and S.K. Tripathy) Structure Properties of Multilayered Thin Films, ed. T.D. Nguyen, Bruce M. Lairsen, Bruce M. Clemens, Sung-Choi Shin, Katsuaki Sato (Mater. Res. Soc. Proc., vol. 382, Pittsburgh, PA) p.265 (1995).
2. "Second-Order Nonlinear Optical Interpenetrating Polymer Networks" (S. Marturunkakul, J.I. Chen L. Li, X.L. Jiang, R.J. Jeng, S. K. Sengupta, J. Kumar, S.K. Tripathy) *Polymers for Second-Order Nonlinear Optics* Edited by Geoffrey A. Lindsay and Kenneth D. Singer, ACS Symposium Series 601, Chapter 15, pp 198 - 204 (1995).

Attachment page 4

**g. Patents granted 1**

1. "Silicon-Containing Networked Non-Linear Optical Compositions" (with R.J. Jeng, Y.M. Chen, A.K. Jain and J. Kumar) Granted U. S. Patent 5,433,895.

Attachment page 5

**h. Invited Presentations 6**

1. "Bulk Self-Assembled Polymers for Nonlinear Optics", Kusatsu, Japan  
ICONO-II Conference July, 1995.
2. "Second Order NLO Properties from self Assembled Asymmetrically  
substituted Polydiacetylene Films", RIKEN, Wakoshi, Japan, July, 1995.
3. "Design of New Polymers for Photonics Application",. Asilomar  
Conference, Monterey, CA, July, 1995.
4. "Polymers for Electronics and Optics", Korean Institute of Science and  
Technology, Seoul, Korea. February, 1996.
5. "Polymers with Enhanced Second-Order Optical Nonlinearities",  
ANTEC'96, Indianapolis, IN, May, 1996.
6. "Optically Induced Holographic Surface Relief Gratings on Polymer  
Films", ACS , Division of Polymer Chemistry, meeting in New Orleans,  
LA, March, 1996.

Attachment page 6

**i. Submitted presentations 8**

1. "Bulk Self Assembled Films for Photonics" (S. K. Tripathy, D. Y. Kim, W. H. Kim, J. Kumar) Electrical, Optical and Magnetic properties of Organic Solid State Materials, ed. Alex K.-Y. Jen, Larry R. Dalton, Gary E. Wnek, Mike F. Rubner, Charles Y.-C. Lee, Long Y. Chiang (Mater. Res. Soc. Symp. Proc., vol. 413, Pittsburgh, PA) (1996).
2. "Processable Thiophene Copolymer with a Chiral Amino Acid side Chain" (s. Balasubramanian, K.G. Chittibabu, J. Kumar, S.K. Tripathy) Electrical, Optical and Magnetic properties of Organic Solid State Materials, ed. Alex K.-Y. Jen, Larry R. Dalton, Gary E. Wnek, Mike F. Rubner, Charles Y.-C. Lee, Long Y. Chiang (Mater. Res. Soc. Symp. Proc., vol. 413, Pittsburgh, PA) pp 695-700 (1996).
3. "Atomic Force Microscopy Studies of Diacetylene Monomers and Polymers" (V. Shivshankar, C. Sung, J. Kumar, S.K. Tripathy and D. J. Sandman) Proceedings, Division of Polymeric Materials: Science and Engineering, Vol. 74 , p. 410, ACS National Meeting, New Orleans, LA, March 1996.
4. "Experimental Studies on Surface Relief Gratings of Polymer Films" (X. L. Jiang, D.Y. Kim, L.Li, V. Shivshankar, J. Kumar and S.K. Tripathy) Electrical, Optical and Magnetic properties of Organic Solid State Materials, ed. Alex K.-Y. Jen, Larry R. Dalton, Gary E. Wnek, Mike F. Rubner, Charles Y.-C. Lee, Long Y. Chiang (Mater. Res. Soc. Symp. Proc., vol. 413, Pittsburgh, PA) (1996).
5. "Chromic Polydiacetylene Single Crystals : Atomic Force Microscopy Studies" (V. Shivshankar, C. Sung, J. Kumar, S.K. Tripathy and D. J. Sandman) Electrical, Optical and Magnetic properties of Organic Solid State Materials, ed. Alex K.-Y. Jen, Larry R. Dalton, Gary E. Wnek, Mike F. Rubner, Charles Y.-C. Lee, Long Y. Chiang (Mater. Res. Soc. Symp. Proc., vol. 413, Pittsburgh, PA) (1996).
6. "Thermally Stable Polyimides for Second-Order Nonlinear Optics", (J.I. Chen, L. Li, S. Marturunkakul, J. Kumar, S.K. Tripathy, G.A. Lindsay, R.D. Miller) Electrical, Optical and Magnetic properties of Organic Solid State Materials, ed. Alex K.-Y. Jen, Larry R. Dalton, Gary E. Wnek, Mike F. Rubner, Charles Y.-C. Lee, Long Y. Chiang (Mater. Res. Soc. Symp. Proc., vol. 413, Pittsburgh, PA) pp. 173-178 (1996).

7. "Epoxy Based Non-Linear Optical Polymers Functionalized with Chromophores Containing Tricyanovinyl Group", (x. Wang, J.I. Chen, S. Marturunkakul, L. Li, J. Kumar, S. K. Tripathy), Electrical, Optical and Magnetic properties of Organic Solid State Materials, ed. Alex K.-Y. Jen, Larry R. Dalton, Gary E. Wnek, Mike F. Rubner, Charles Y.-C. Lee, Long Y. Chiang (Mater. Res. Soc. Symp. Proc., vol. 413, Pittsburgh, PA) pp. 275-280 (1996).
8. "Polyamic Acid Langmuir-Blodgett (LB) Films Containing a Stable Second Order NLO Chromophore" (D.W. Cheong, J. I. Chen, J. Kumar, S.K. Tripathy) Electrical, Optical and Magnetic properties of Organic Solid State Materials, ed. Alex K.-Y. Jen, Larry R. Dalton, Gary E. Wnek, Mike F. Rubner, Charles Y.-C. Lee, Long Y. Chiang (Mater. Res. Soc. Symp. Proc., vol. 413, Pittsburgh, PA) pp.281-285 (1996).

Attachment page 7

**j. Honors/Awards/Prizes**

Mr. Shivshankar Venkataramani, finalist in Sherwin Williams Student Award Competition, Division of Polymeric Materials: Science and Engineering Division of Polymer Chemistry, 1996.