

NOVEMBER 1993

REPORT NO. 93-03

MODULAR AVIATION
RESUPPLY/REARM
SYSTEM (MARRS)

19960807 008

Prepared for:
Office of the Project Manager,
Ammunition Logistics
ATTN: AMCPM-AL
Picatinny Arsenal, NJ 07806-5000

Distribution Unlimited



VALIDATION ENGINEERING DIVISION

SAVANNA, ILLINOIS 61074-9639 DTIC QUALITY INSPECTED 1

DISCLAIMER NOTICE

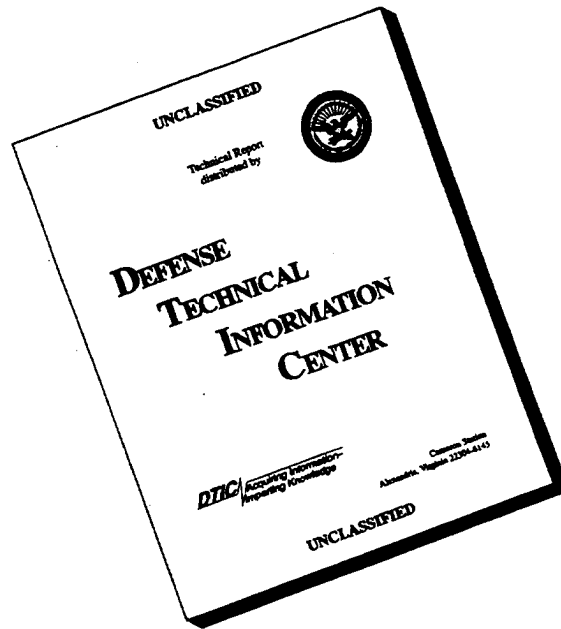

THIS DOCUMENT IS BEST QUALITY AVAILABLE. THE COPY FURNISHED TO DTIC CONTAINED A SIGNIFICANT NUMBER OF PAGES WHICH DO NOT REPRODUCE LEGIBLY.

AVAILABILITY NOTICE

A copy of this report will be furnished each attendee on automatic distribution. Additional copies or authority for reprinting may be obtained by written request from Director, U.S. Army Defense Ammunition Center and School, ATTN: SIOAC-DEV, Savanna, IL 61074-9639.

DISTRIBUTION INSTRUCTIONS

Destroy this report when no longer needed. Do not return.

Citation of trade names in this report does not constitute an official endorsement.

The information contained herein will not be used for advertising purposes.

REPORT DOCUMENTATION PAGE				Form Approved OMB No. 0704-0188	
1a. REPORT SECURITY CLASSIFICATION UNCLASSIFIED		1b. RESTRICTIVE MARKINGS			
2a. SECURITY CLASSIFICATION AUTHORITY		3. DISTRIBUTION / AVAILABILITY OF REPORT UNLIMITED			
2b. DECLASSIFICATION / DOWNGRADING SCHEDULE					
4. PERFORMING ORGANIZATION REPORT NUMBER(S) 93-03		5. MONITORING ORGANIZATION REPORT NUMBER(S)			
6a. NAME OF PERFORMING ORGANIZATION U.S. Army Defense Ammunition Center and School		6b. OFFICE SYMBOL (if applicable) SIOAC-DEV	7a. NAME OF MONITORING ORGANIZATION		
6c. ADDRESS (City, State, and ZIP Code) ATTN: SIOAC-DEV Savanna, IL 61074-9639		7b. ADDRESS (City, State, and ZIP Code)			
8a. NAME OF FUNDING / SPONSORING ORGANIZATION Office of the Project Manager, Ammunition Logistics		8b. OFFICE SYMBOL (if applicable) AMCPM-AL	9. PROCUREMENT INSTRUMENT IDENTIFICATION NUMBER		
8c. ADDRESS (City, State, and ZIP Code) ATTN: AMCPM-AL Picatinny Arsenal, NJ 07806-5000		10. SOURCE OF FUNDING NUMBERS			
		PROGRAM ELEMENT NO.	PROJECT NO.	TASK NO.	WORK UNIT ACCESSION NO.
11. TITLE (Include Security Classification) Modular Aviation Resupply/Rearm System (MARRS)					
12. PERSONAL AUTHOR(S) Quinn D. Hartman					
13a. TYPE OF REPORT Final		13b. TIME COVERED FROM TO _____		14. DATE OF REPORT (Year, Month, Day) 1993 November	
15. PAGE COUNT					
16. SUPPLEMENTARY NOTATION					
17. COSATI CODES			18. SUBJECT TERMS (Continue on reverse if necessary and identify by block number)		
FIELD	GROUP	SUB-GROUP			
19. ABSTRACT (Continue on reverse if necessary and identify by block number)					
<p>The U.S. Army Defense Ammunition Center and School (USADACS), Validation Engineering Division (SIOAC-DEV), was tasked by the Office of the Project Manager, Ammunition Logistics (PM-AMMOLOG) to develop and evaluate overcube ammunition loads for the Apache helicopter on the M977 Heavy Expanded Mobility Tactical Truck (HEMTT) and M1075 Palletized Loading System (PLS) truck as part of the Modular Aviation Resupply/Rearm System (MARRS). The load tested consisted of a mixture of HELLFIRE, 2.75-inch rockets, and 30mm ammunition pallets stacked two high. A road hazard transportability test was conducted on the test load on each vehicle in order to assess the tiedown procedures. Results from the testing indicated that the tiedown procedures were adequate for the shipment of this Apache helicopter resupply load.</p>					
20. DISTRIBUTION / AVAILABILITY OF ABSTRACT <input checked="" type="checkbox"/> UNCLASSIFIED/UNLIMITED <input type="checkbox"/> SAME AS RPT. <input type="checkbox"/> DTIC USERS			21. ABSTRACT SECURITY CLASSIFICATION UNCLASSIFIED		
22a. NAME OF RESPONSIBLE INDIVIDUAL JEROME H. KROHN		22b. TELEPHONE (Include Area Code) 815-273-8929		22c. OFFICE SYMBOL SIOAC-DEV	

U.S. ARMY DEFENSE AMMUNITION CENTER AND SCHOOL
VALIDATION ENGINEERING DIVISION
SAVANNA, IL 61074-9639

REPORT NO. 93-03

MODULAR AVIATION RESUPPLY/REARM SYSTEM (MARRS)

TABLE OF CONTENTS

PART	PAGE NO.
1. INTRODUCTION	1-1
A. BACKGROUND	1-1
B. AUTHORITY	1-1
C. OBJECTIVE	1-1
D. CONCLUSION	1-1
2. ATTENDEES	2-1
3. TEST PROCEDURES	3-1
4. TEST RESULTS	4-1
5. PHOTOGRAPHS	5-1
6. DRAWINGS	6-1

PART 1

INTRODUCTION

A. BACKGROUND. The U.S. Army Defense Ammunition Center and School (USADACS), Validation Engineering Division (SIOAC-DEV), was tasked by the Office of the Project Manager, Ammunition Logistics (PM-AMMOLOG) to develop and evaluate overcube ammunition loads for the Apache helicopter on the M977 Heavy Expanded Mobility Tactical Truck (HEMTT) and M1075 Palletized Loading System (PLS) truck as part of the Modular Aviation Resupply/Rearm System (MARRS).

B. AUTHORITY. The test was accomplished IAW mission responsibilities delegated by U.S. Army Armament, Munitions and Chemical Command (AMCCOM), Rock Island, IL. Reference is made to the following:

1. Change 4, 4 October 1974, to AR740-1, 23 April 1973, Storage and Supply Activity Operation.

2. AMCCOM-R 10-17, Mission and Major Functions of USADACS, 13 January 1986.

C. OBJECTIVE. The objective of this test was to determine if the Apache helicopter resupply load developed at USADACS was adequate for safe transportation of resupply commodities on- and off-road.

D. CONCLUSION. The Apache helicopter resupply load developed by USADACS successfully passed the road hazard course test on both the M977 HEMTT and M1075 PLS truck. As tested, the Apache helicopter resupply load developed by USADACS is approved for on/off-road transportation on both the M977 HEMTT and M1075 PLS truck.

PART 2

27-28 SEPTEMBER AND 11 OCTOBER 1993

ATTENDEES

Quinn D. Hartman
General Engineer
DSN 585-8992
815-273-8992

Director
U.S. Army Defense Ammunition Center
and School
ATTN: SIOAC-DEV
Savanna, IL 61074-9639

John D. Simons
Industrial Engineer
DSN 585-8074
815-273-8074

Director
U.S. Army Defense Ammunition Center
and School
ATTN: SIOAC-DET
Savanna, IL 61074-9639

Lenny Frelich
DSN 880-2539

Commander
Defense Ammunition Logistics Activity
ATTN: AMSTA-AR-ALS
Picatinny Arsenal, NJ 07806-5000

PART 3

TEST PROCEDURES

TRANSPORTABILITY TESTS. The test procedures outlined in this section were extracted from TP-91-01. This standard identifies six steps that a load must undergo if it is considered to be acceptable. The tests that were conducted on the test specimen are synopsized below.

A. ROAD HAZARD COURSE. The specimen tested was subjected to the road hazard course (see Figure 1). Using a suitable truck/tractor or tactical vehicle, the vehicle/specimen was towed/driven over a hazard course two times at a speed of approximately 5 mph. The speed was increased or decreased, as appropriate, to produce the most violent load response.

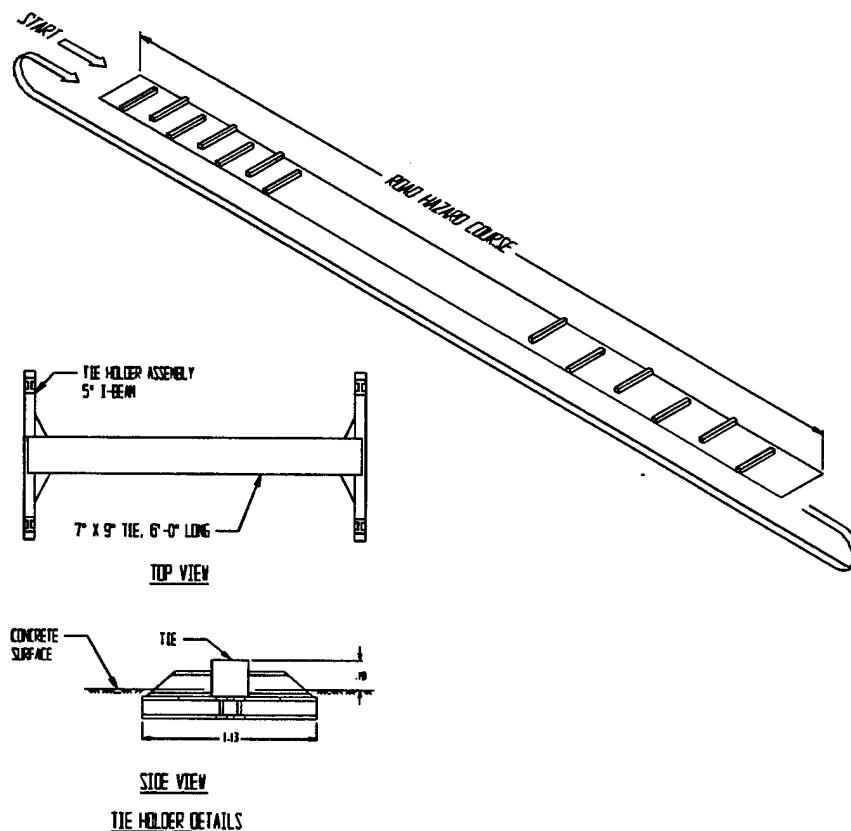

FIGURE 1

B. ROAD TRIP. Using a suitable truck/tractor and trailer, or tactical vehicle, the tactical vehicle/specimen load was driven/towed for a total distance of at least 30 miles over a combination of roads surfaced with gravel, concrete, and asphalt. The test route included curves, corners, railroad crossings, cattle guards, stops, and starts. The test vehicle traveled at the maximum speed suitable for the particular road being traversed, except as limited by legal restrictions.

C. WASHBOARD COURSE. Using a suitable truck/tractor, and/or tactical vehicle, the specimen was towed/driven over the washboard course at a speed which produced the most violent response in the particular test load (see Figure 2).

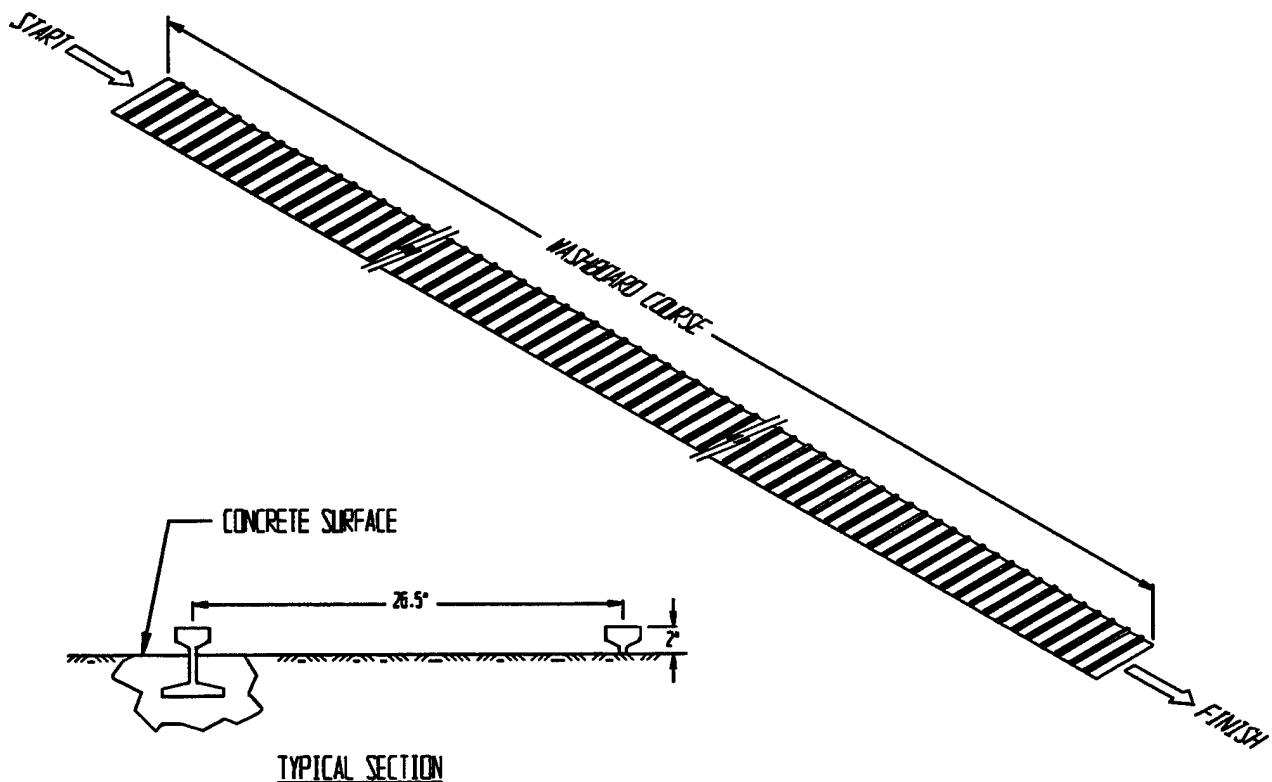

FIGURE 2

C. WASHBOARD COURSE. Using a suitable truck/tractor, and/or tactical vehicle, the specimen was towed/driven over the washboard course at a speed which produced the most violent response in the particular test load (see Figure 2).

PART 4

TEST RESULTS

A. SYNOPSIS OF TEST NO. 1. In test No. 1, the rearm load for three Apache helicopters was tested on an M977 HEMTT. The load consisted of 2 pallets of 30mm ammunition, 3 pallets of HELLFIRE missiles, and 3 pallets of 2.75-inch rockets. The rearm load was secured to the HEMTT with 27 web straps. While there were several inches of racking of the pallets that were stacked two-high during the test, the pallets remained secured to the truck throughout the test. Approval was granted to this configuration on an M977 HEMTT. (See photos on pages 5-2 and 5-3, and page 10 of drawing, Project DA 16-93 in Part 6.)

ROAD TEST DATA FROM TEST NO. 1

2 NOVEMBER 1993

Rearm load for three Apache Helicopters on an M977 HEMTT:

Load weight: 19,163 pounds.

ROAD HAZARD COURSE.

Pass 1, Course A: 5.06 SEC, 6.74 MPH

Pass 1, Course B: 5.43 SEC, 6.28 MPH

Remarks: At the end of the first pass, the HELLFIRE missile pallets were noted to have shifted backwards 1/4-inch and the 2.75-inch rocket pallets had shifted forward 1/4-inch.

Pass 2, Course A: 5.05 SEC, 6.75 MPH

Pass 2, Course B: 5.35 SEC, 6.37 MPH

Remarks: No additional movement of the pallets was noted following completion of the second pass over the road hazard course.

30-MILE ROAD TEST. The 30-mile road test resulted in the top pallet of HELLFIRE missiles shifting backwards 1-1/2 inches.

PANIC STOPS. During the panic stops, the upper HELLFIRE and 2.75-inch rocket pallets were noted to have racked several inches but returned to original position following each stop.

ROAD HAZARD COURSE.

Pass 3, Course A: 5.36 SEC, 6.36 MPH

Pass 3, Course B: 5.68 SEC, 6.00 MPH

Remarks: No additional movement of the pallets was noted following completion of the third pass over the road hazard course.

Pass 4, Course A: 5.19 SEC, 6.57 MPH

Pass 4, Course B: 5.45 SEC, 6.26 MPH

Remarks: No additional movement of the pallets was noted following completion of the fourth pass over the road hazard course.

WASHBOARD COURSE. 51.7 SEC, 3.96 MPH

Remarks: No additional movement of the pallets was noted following completion of the washboard course.

B. SYNOPSIS OF TEST NO. 2. In test No. 2, the rearm load for three Apache helicopters was tested on an M1075 PLS truck. The load was secured to the PLS truck in the same manner in which it was secured to the M977 HEMTT. Transportability testing produced similar results for the rearm load on the PLS truck. Several inches of racking of the upper pallets were noted during the test; however, the pallets remained secured to the PLS truck throughout the test. Approval was also granted for this configuration on an M1075 PLS truck. (See photos on pages 5-4 and 5-5, and page 10 of drawing, Project DA 16-93 in Part 6.)

ROAD TEST DATA FROM TEST NO. 2

2 NOVEMBER 1993

Rearm Load for three Apache helicopters on an M1075 PLS truck:

Load weight: 19,163 pounds.

ROAD HAZARD COURSE.

Pass 1, Course A: 7.86 SEC, 4.34 MPH

Pass 1, Course B: 8.16 SEC, 4.18 MPH

Remarks: At the end of the first pass, the 2.75-inch rocket pallets had shifted backwards 1/4-inch. No additional movement was noted in the other pallets.

Pass 2, Course A: 7.84 SEC, 4.35 MPH

Pass 2, Course B: 7.97 SEC, 4.28 MPH

Remarks: No additional movement of the pallets was noted following completion of the second pass over the road hazard course.

30-MILE ROAD TEST. No additional movement was noted following completion of the 30-mile road test.

PANIC STOPS. During the panic stops, several inches of racking were noted in the upper HELLFIRE and 2.75-inch rocket pallets. Following completion of the stops, the upper 2.75-inch rocket pallet was noted to have shifted forward 1/2-inch. No additional movement was noted in the other pallets.

ROAD HAZARD COURSE.

Pass 3, Course A: 7.75 SEC, 4.40 MPH

Pass 3, Course B: 7.96 SEC, 4.28 MPH

Remarks: No additional movement of the pallets was noted following completion of the third pass over the road hazard course.

Pass 4, Course A: 7.69 MPH, 4.43 MPH

Pass 4, Course B: 7.53 MPH, 4.53 MPH

Remarks: At the end of the fourth and final pass, the top 2.75-inch rocket pallet was noted to have shifted 2 inches left of the bottom pallet. No additional movement was noted in the other pallets.

WASHBOARD COURSE. 65.5 SEC, 3.12 MPH

Remarks: No additional movement of the pallets was noted following completion of the washboard course.

PLS FLATRACK LOADING/UNLOADING. Loading and unloading of the PLS flatrack was conducted in order to verify that the pallets would remain secured to the flatrack through the operations. No major shifting of the pallets on the flatrack was noted during loading or unloading operations.

PART 5

PHOTOGRAPHS

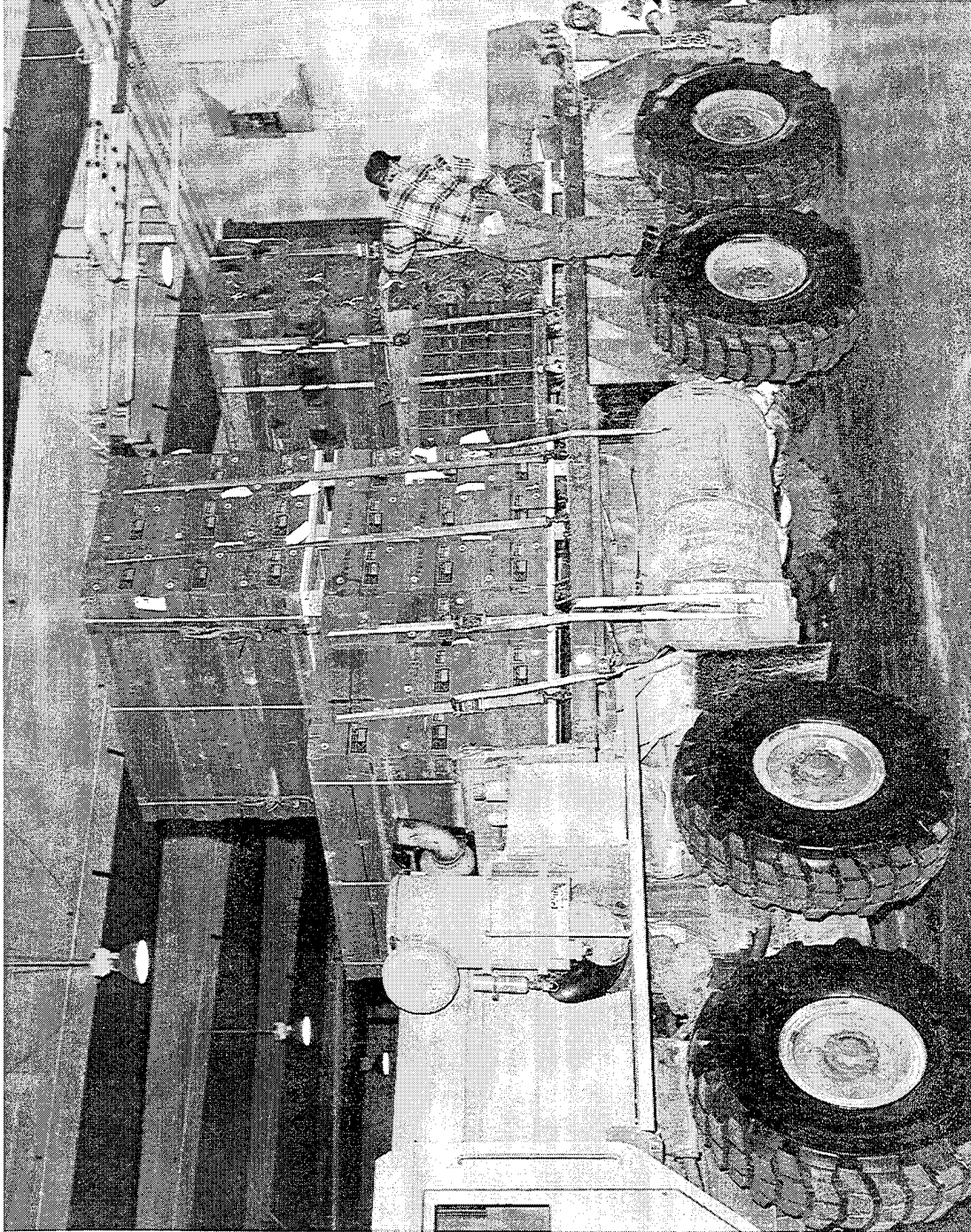

U.S. ARMY DEFENSE AMMUNITION CENTER AND SCHOOL -
SAVANNA, IL

Photo No. AO317-SPN-94-025-220. This photo shows the side view of the rear arm load for three Apache helicopters on an M977 HEMTT.

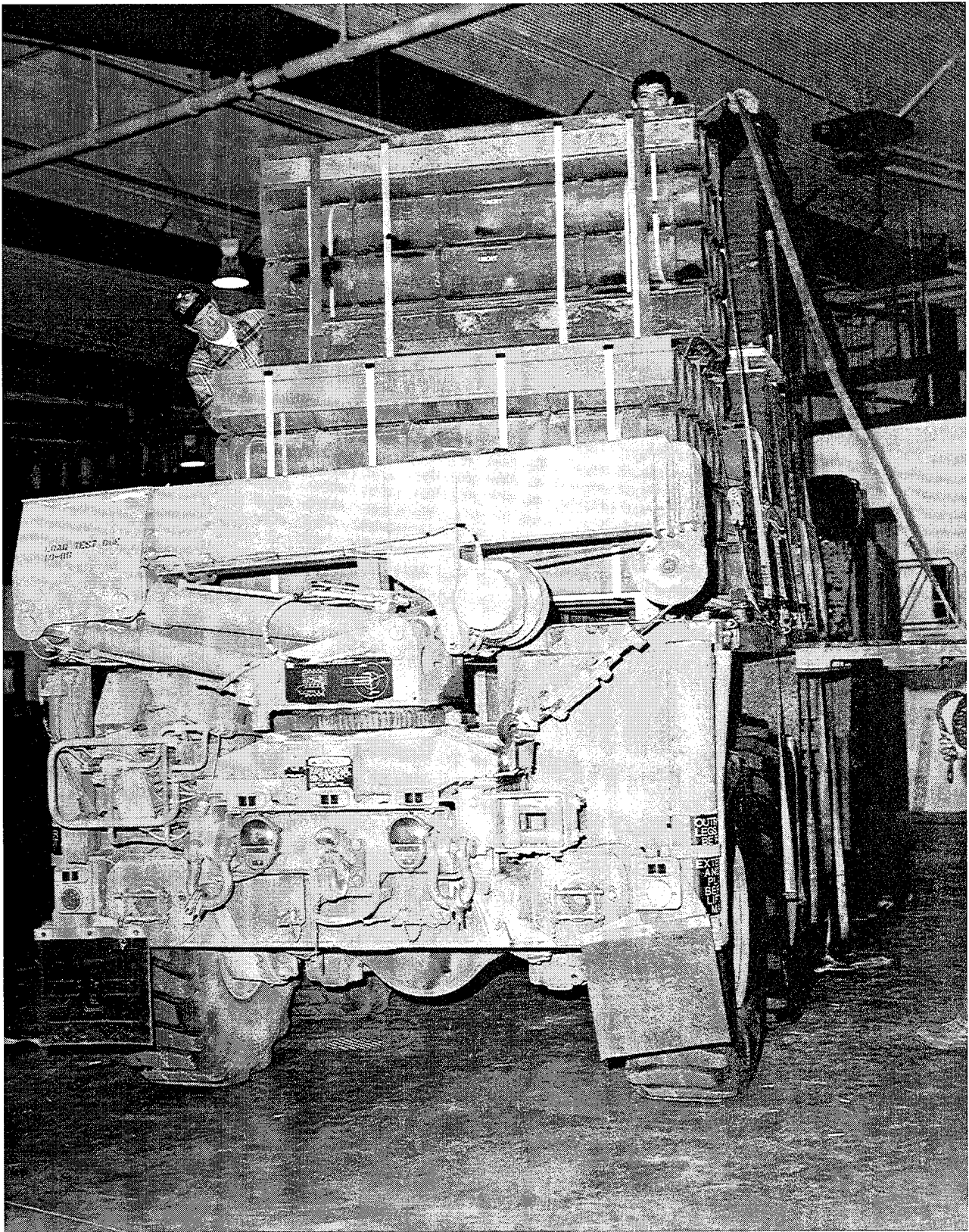

U.S. ARMY DEFENSE AMMUNITION CENTER AND
SCHOOL - SAVANNA, IL

Photo No. AO317-SPN-94-025-219. This photo shows the end view of the rearm load for three Apache helicopters on an M977 HEMTT.

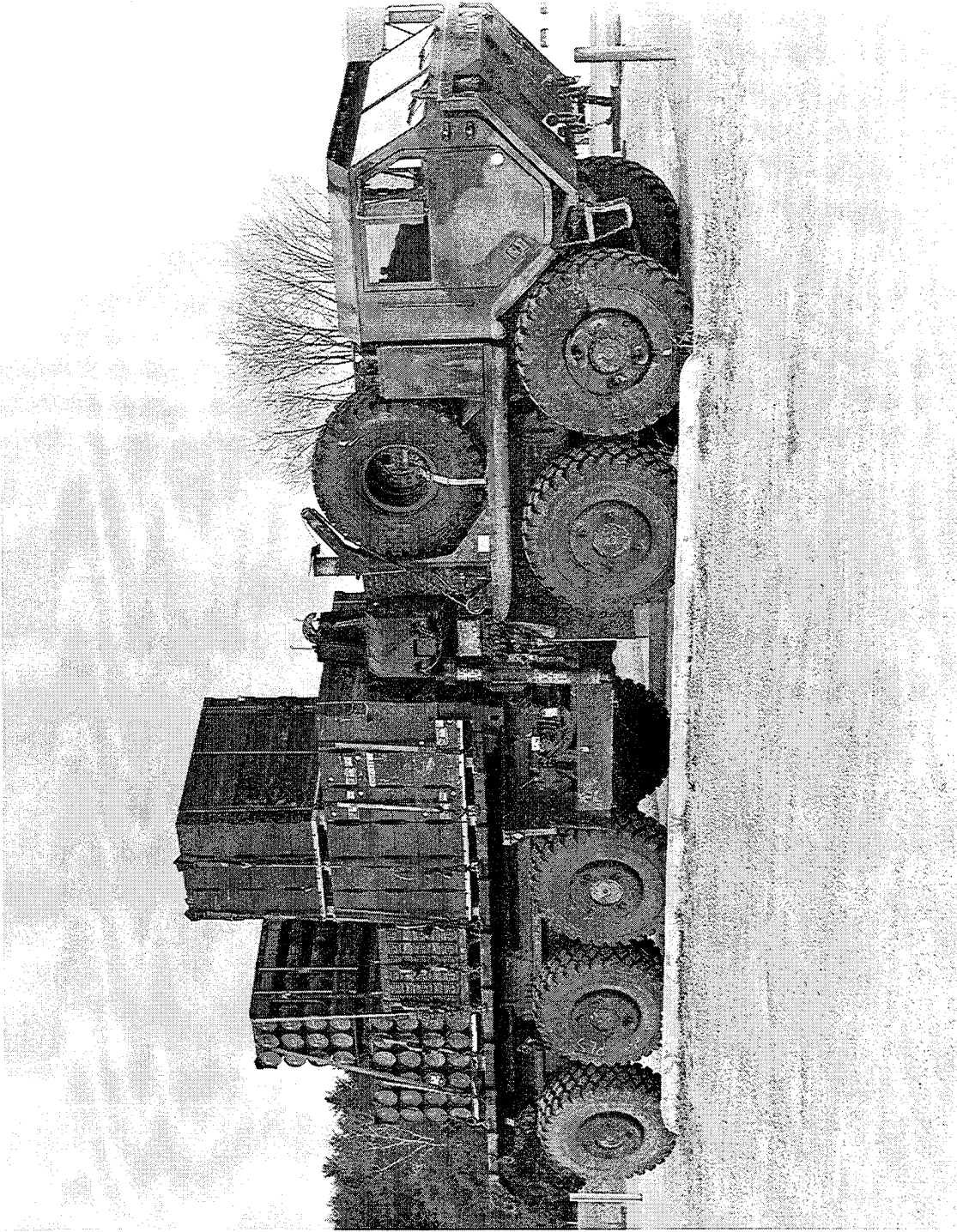

U.S. ARMY DEFENSE AMMUNITION CENTER AND SCHOOL -
SAVANNA, IL

Photo No. AO317-SPN-94-025-223. This photo shows the side view of the rearm load for three Apache helicopters on an M1075 PLS truck.



U.S. ARMY DEFENSE AMMUNITION CENTER AND SCHOOL - SAVANNA, IL	
---	--

Photo No. AO317-SPN-94-025-225. This photo shows the end view of the rearm load for three Apache helicopters on an M1075 PLS truck.
--

PART 6

DRAWINGS

LOADING AND TIEDOWN PROCEDURES FOR THE AH64 APACHE HELICOPTER AMMUNITION FOR THE MODULAR AVIATION RESUPPLY/REARM SYSTEM (MARRS) IN/ON TACTICAL VEHICLES

INDEX

<u>ITEM</u>	<u>PAGE(S)</u>
GENERAL NOTES AND MATERIAL SPECIFICATIONS - - - - -	2
ITEMIZED INDEX - - - - -	3
REARM FOR ONE APACHE HELICOPTER ON THE 5-TON M925A1 CARGO TRUCK - - - - -	4,5
REARM FOR ONE THROUGH THREE APACHE HELICOPTERS ON THE 10-TON M977 AND/OR M985 HEMTT - - - - -	6-11
REARM FOR ONE THROUGH THREE APACHE HELICOPTERS ON THE 11-TON M989A1 HEMAT - - - - -	12-17
REARM FOR ONE THROUGH FOUR APACHE HELICOPTERS ON THE 16-1/2-TON M1077 A-FRAME FLATRACK AND THE M1 FLATRACK - - - - -	18-25

DEPARTMENT OF ARMY DRAWING			
	DRAFTSMAN	TECHNICIAN	ENGINEER
	B. LEONARD		J. SIMONS
	VALIDATION ENGINEERING DIVISION	TRANSPORTATION ENGINEERING DIVISION	LOGISTICS ENGINEERING OFFICE
APRIL 1994	<i>ASST. W. F. Ernst</i>		
DRAWING NUMBER	APPROVED BY ORDER OF COMMANDING GENERAL, U.S. ARMY MATERIEL COMMAND		
DA-115	<i>William F. Ernst</i> U.S. ARMY DEFENSE AMMUNITION CENTER AND SCHOOL		

DO NOT SCALE

GENERAL NOTES

- A. THIS DOCUMENT HAS BEEN PREPARED AND ISSUED IN ACCORDANCE WITH AR-740-1.
- B. THIS DRAWING COVERS PROCEDURES APPLICABLE TO THE TRANSPORT OF AH64 APACHE HELICOPTER AMMUNITION LOADED ON TACTICAL VEHICLES AND SECURED WITH WEB STRAP TIEDOWN ASSEMBLIES, FOR ON AND/OR OFF HIGHWAY. SEE PAGE 29 FOR AUTHORIZED ARMAMENT CONFIGURATIONS FOR THE AH64 APACHE.
- C. DEPICTED PROCEDURES APPLY TO TACTICAL VEHICLES HAVING FACTORY INSTALLED TIEDOWN ANCHORS AND/OR TACTICAL VEHICLES WHICH HAVE BEEN MODIFIED TO INCLUDE THE UNIVERSALLY APPLICABLE "TIEDOWN KIT" WHICH CONSISTS OF THE TIEDOWN FITTINGS OR ANCHOR DEVICES FOR INSTALLATION IN/ON CARGO BEDS, SIDE WALLS, AND/OR END WALLS, FOR USE WITH WEB STRAP TIEDOWN ASSEMBLIES. SEE PAGE 30 FOR GUIDANCE.
- D. ALL LOADS SHOWN HEREIN ARE TYPICAL AND ARE BASED ON TESTED PROCEDURES FOR OFF HIGHWAY TRANSPORT. COMBINATIONS OF PROCEDURES MAY BE USED. HOWEVER, THE APPROVED METHODS SPECIFIED HEREIN MUST BE FOLLOWED AS CLOSELY AS POSSIBLE.
- E. BECAUSE OF THE FACT THAT ALL LOADS HEREIN ARE TYPICAL IT IS MOST LIKELY THAT THE ACTUAL ITEM OR QUANTITY TO BE TRANSPORTED WILL NOT BE DEPICTED. IN ORDER TO MAINTAIN SIMILARITY FROM ONE LOAD TO ANOTHER, INSTALLATIONS SHOULD MAKE AN ACTUAL PENCIL SKETCH OF THE LOAD, USING THE VARIOUS TYPICAL LOADS AND PROCEDURES SHOWN HEREIN FOR GUIDANCE. THE SKETCH WOULD BE ADVANTAGEOUS FOR MAXIMUM LOADS USING A MINIMUM QUANTITY OF WEB STRAP TIEDOWN ASSEMBLIES.
- F. WEB STRAP TIEDOWN ASSEMBLIES MUST BE SECURELY HOOKED INTO ANCHORING DEVICES ON THE TRANSPORTING VEHICLE AND FIRMLY TENSIONED. FIRMLY TENSIONED MEANS, WHEN THE OPERATOR PULLS ON THE RATCHET HANDLE BY HAND, THE RATCHET WILL NOT ADVANCE ANOTHER NOTCH. NO TYPE OF MECHANICAL EXTENSION OR LEVER WILL BE USED. EXERCISE CARE DURING STRAP APPLICATION. AVOID TWISTS IN THE STRAP TO THE EXTENT POSSIBLE (IF TIME PERMITS) BUT ENSURE THERE ARE NO KNOTS IN THE STRAP. ON THE TAKE-UP SPOOL OF THE RATCHET, ENSURE STRAIGHT LAY OF THE STRAP WHEN TENSIONING. AFTER INITIAL WEBBING-TO-WEBBING CONTACT HAS BEEN MADE, BY ROTATING THE TAKE-UP SPOOL UNTIL NO METAL ON THE SPOOL IS SHOWING AND THE STRAP HAS MADE CONTACT WITH ITSELF, THE TENSIONED STRAP MUST FORM AT LEAST 1/2 BUT NOT MORE THAN 1-1/2 WRAPS OF STRAP ON THE TAKE-UP SPOOL OF THE TENSIONING RATCHET. AFTER TENSIONING IS COMPLETED, ENSURE THAT THE SPOOL LOCKING LATCH IS FULLY SEATED AT BOTH ENDS OF THE SPOOL IN MATCHING LOCKING NOTCHES. TIE BACK THE LOOSE END OF THE STRAP AFTER TENSIONING IS COMPLETED (LOOSE ENDS MAY BE FOLDED AND TAPED OR TIED TO THE TENSIONING STRAP IF TIME PERMITS). FOR ADDITIONAL GUIDANCE, SEE "RATCHET/RATCHETING DETAILS" ON PAGES 26 AND 27.
- G. ADJUSTABLE SCUFF SLEEVES PROVIDED ON WEB STRAP ASSEMBLIES WILL BE LOCATED TO PROVIDE A PAD WHERE STRAPS PASS OVER SHARP EDGES, OR RATCHETS AND HOOKS ON PREVIOUSLY INSTALLED WEB STRAP TIEDOWN ASSEMBLIES.
- H. PROCEDURES DEPICTED HEREIN ARE TYPICAL IN NATURE RELATIVE TO ITEM LOCATION IN/ON THE FLATRACK AND THE QUANTITIES SHOWN. ITEM LOCATION AND QUANTITIES OF THE DESIGNATED ITEM MAY BE VARIED TO SATISFY OPERATIONAL REQUIREMENTS, PROVIDED LOADING AND TIEDOWN PRINCIPLES SPECIFIED HEREIN ARE RETAINED.
- J. WHEN ONE WEB STRAP TIEDOWN ASSEMBLY IS NOT LONG ENOUGH TO SPAN THE DISTANCE DEPICTED, TWO ASSEMBLIES MAY BE HOOKED TOGETHER TO GAIN THE NECESSARY LENGTH.

(CONTINUED AT RIGHT)

MATERIAL SPECIFICATIONS

STRAP - - - - - : WEBBING, UNIVERSAL TIEDOWN,
NSN 5340-01-204-3009, PN9392419, OR
NSN 5340-01-089-4997, PN11669588, OR
NSN 1670-00-725-1437, PN1376-013, OR
NSN 5340-00-980-9277, PN10900880.

ANTI-CHAFING
MATERIAL - - - - - : CANVAS, BURLAP, TAPE OR ANY OTHER
SUITABLE MATERIAL.

(GENERAL NOTES CONTINUED)

- K. AFTER ALL LOADING PROCEDURES ARE COMPLETE, CHECK ALL WEB STRAP TIEDOWN ASSEMBLIES FOR MAXIMUM TIGHTNESS AND RATCHET TIGHTER IF REQUIRED, PRIOR TO FOLDING UP AND SECURING THE LOOSE ENDS OF THE STRAP AS INSTRUCTED IN GENERAL NOTE "F".
- L. DURING LONG HAULS THE WEB STRAPS SHOULD BE CHECKED AT ALL VEHICLE STOPS AND TIGHTENED IF NECESSARY.
- M. DUE TO VARIOUS REASONS, SUCH AS ROUGH TERRAIN DURING OFF HIGHWAY TRANSPORT, PANIC STOPS, METAL FLOORS, AND NORMAL STRETCH OF WEB STRAPS, LOADED ITEMS MAY SLIDE SLIGHTLY Laterally AND/OR LONGITUDINALLY DURING TRANSPORT. THIS IS AN ACCEPTABLE CHARACTERISTIC AND IS NOT DETRIMENTAL TO LOAD SECUREMENT.
- N. THE TIEDOWN METHODS WITHIN THIS DRAWING SHOW TWO STRAP HOOKS CONNECTED TO THE SAME TIEDOWN ANCHOR. THIS IS AUTHORIZED AS SPECIFIED HEREIN.
- O. CONVERSION TO METRIC EQUIVALENTS: DIMENSIONS WITHIN THIS DOCUMENT ARE EXPRESSED IN INCHES, AND WEIGHTS ARE EXPRESSED IN POUNDS. WHEN NECESSARY, THE METRIC EQUIVALENTS MAY BE COMPUTED ON THE BASIS OF ONE INCH EQUALS 25.4MM AND ONE POUND EQUALS 0.454 KG.
- P. ONLY THE CARGO BODIES OR BEDS OF THE TACTICAL VEHICLES HAVE BEEN SHOWN HEREIN TO PREVENT DISTRACTION FROM THE DELINEATED LOADING AND TIEDOWN PROCEDURES, AND ARE SHOWN IN OUTLINE FORM WITH THE STRUCTURAL PORTIONS OMITTED AS NECESSARY TO IMPROVE THE CLARITY OF THE DEPICTED PROCEDURES.
- Q. THE PALLETIZED LOADING SYSTEM (PLS) M1077 A-FRAME FLATRACK HAS AN ALL METAL DECK. THE EMPTY WEIGHT IS 3,200 POUNDS AND THE LOAD CAPACITY IS 33,000 POUNDS. THE MI ISO COMPATIBLE PLS FLATRACK (IPF) HAS A WOOD AND METAL DECK. THE EMPTY WEIGHT IS 7,500 POUNDS AND THE LOAD CAPACITY IS 28,750 POUNDS.
- R. EACH FLATRACK IS PROVIDED WITH 22 WEB STRAP TIEDOWN ASSEMBLIES. SIDE BOARD KITS AND CARGO COVERS ARE NOT PROVIDED, BUT ARE CONTAINED ON THE ADDITIONAL AUTHORIZED LIST (AAL) AND MAY BE OBTAINED THROUGH THE ARMY SUPPLY SYSTEM.
- S. ONE MI FLATRACK CAN BE LOADED ON AN M871 SEMITRAILER, AND TWO CAN BE LOADED ON AN M872 SEMITRAILER, USING THE FOUR BOTTOM ISO CORNER FITTINGS.
- T. THE FLATRACKS ARE CAPABLE OF BEING TRANSPORTED ON C-130, C-141, C-5, AND C-17 AIRCRAFT.
- U. THE FLATRACKS ARE CAPABLE OF BEING SLING-LIFTED BY A CH-47 HELICOPTER WITH A REDUCED PAYLOAD. THE MAXIMUM WEIGHT FOR SLING-LIFT IS 22,900 POUNDS.
- V. FOR ADDITIONAL GUIDANCE SEE THE "LOADING PROCEDURES" ON PAGE 3 AND THE "SPECIAL NOTES" ON EACH LOAD PAGE.

LOADING AND TIEDOWN PROCEDURES:

1. BEFORE LOADING A PLS FLATRACK OR ANY OTHER TACTICAL VEHICLE WITH AMMUNITION OR EXPLOSIVES, CHECK THE OVERALL CONDITION TO ENSURE IT IS SERVICEABLE. CHECK FOR CRACKS, BREAKS, DISTORTIONS, OR EXCESSIVE CORROSION WHICH WOULD MAKE USE UNSAFE. CHECK THE CARGO TIEDOWN ANCHORS AND THE FLATRACK TIEDOWN DEVICES TO INSURE THEY ARE SERVICEABLE. MAKE SURE THEY ARE NOT CRACKED, BROKEN, BENT, DISTORTED OR EXCESSIVELY CORRODED TO PRECLUDE SAFE USE. GIVE SPECIAL ATTENTION WHILE CHECKING THE LIFTING DEVICE ON THE HOOKUP END OF THE PLS FLATRACK. MAKE SURE THE HOOKUP DEVICE IS NOT CRACKED, BROKEN, WORN, OR DISTORTED TO SUCH AN EXTENT SO AS TO MAKE THE DEVICE UNSERVICEABLE OR UNSAFE TO USE.
2. FOR THE PLS, CHECK THE END WALLS ON THE M1 FLATRACK TO ASSURE THAT THEY CAN BE RAISED AND/OR LOWERED WITHOUT DIFFICULTY. FOLLOW THE MANUFACTURERS STEP-BY-STEP PROCEDURES FOR RAISING AND/OR LOWERING THE END WALLS AS SERIOUS INJURY OR DEATH TO PERSONNEL COULD RESULT DUE TO THE 1,700 POUND WEIGHT OF THE FRONT WALL AND THE 1,100 POUND WEIGHT OF THE REAR WALL.
3. BOTH PLS FLATRACKS ARE EQUIPPED WITH ELEVEN TIEDOWN ANCHORS ALONG EACH SIDE. THE TIEDOWN ANCHORS AT EACH END AND IN THE CENTER HAVE A 25,000 POUND CAPACITY AND THE REMAINING EIGHT TIEDOWN ANCHORS HAVE A 10,000 POUND CAPACITY. ALL ELEVEN TIEDOWN ANCHORS WILL ACCEPT WEB STRAP TIEDOWN ASSEMBLIES OR STEEL STRAPPING.
4. TWO SETS OF FORKLIFT POCKETS ARE PROVIDED UNDERNEATH THE PLS M1077 A-FRAME AND M1 FLATRACKS. THE SET NEAR THE ENDS OF THE FLATRACK MUST BE USED WHEN LIFTING LOADED FLATRACKS. THE SET CLOSEST TO THE CENTER OF THE FLATRACK IS FOR LIFTING UNLOADED FLATRACKS ONLY. USE OF THE WRONG FORKLIFT POCKETS COULD CAUSE DAMAGE TO EQUIPMENT. THE FORKS ON THE FORKLIFT MUST BE 70.00" LONG OR LONGER.
5. FOR THE PLS, POSITION FULL AND/OR PARTIAL LOADS TIGHT AGAINST THE A-FRAME AT THE FORWARD END OF THE M1077 FLATRACK OR THE FRONT WALL ON THE M1 FLATRACK. IF DESIRED, PARTIAL LOADS MAY BE POSITIONED ANYWHERE ON THE LENGTH OF THE FLATRACK, HOWEVER, ONE MORE WEB STRAP TIEDOWN ASSEMBLY WILL BE REQUIRED. POSITION THIS STRAP FROM A TIEDOWN ANCHOR ON THE SIDE OF THE FLATRACK AROUND PALLET BASES ON FORWARD PALLETS, TO A TIEDOWN ANCHOR ON THE OPPOSITE SIDE OF THE FLATRACK.
6. WHEN ATTACHING THE WEB STRAP HOOK TO THE TIEDOWN ANCHOR ON A PLS FLATRACK ASSURE THAT THE TIEDOWN ANCHOR IS IN A RAISED OR VERTICAL POSITION PRIOR TO AND AFTER THE STRAP IS TIGHTENED. IF THE WEB STRAP IS POSITIONED AT A NEAR HORIZONTAL ANGLE, SUCH AS STRAP MARKED ② ON PAGE 18, ASSURE THAT THE TIEDOWN ANCHOR IS POSITIONED IN LINE WITH THE PULL OF THE STRAP WHEN POSSIBLE. HOWEVER, IF TWO STRAPS ARE ATTACHED TO THE SAME TIEDOWN ANCHOR THE VERTICAL STRAP HAS PRECEDENCE.
7. DO NOT POSITION PALLET UNITS AGAINST THE SIDE WALLS OF THE 10-TON M977 AND/OR M985 HEMTT. THESE WALLS CANNOT SUPPORT THE LOAD WEIGHT AND MAY BE DAMAGED.
8. PRIOR TO LOADING ITEMS ON THE VEHICLES AND/OR FLATRACKS, ASSURE THAT THE DECK IS FREE OF EXCESSIVE AMOUNTS OF DIRT, SAND AND GRAVEL.
9. WHEN LOADING PALLETS ON THE VEHICLES AND/OR FLATRACKS, DO NOT STACK PALLETS TWO HIGH UNLESS IT IS NECESSARY TO ACHIEVE THE DESIRED RELOAD QUANTITY.
10. **CAUTION:** WHEN TRANSPORTING LOADS HAVING PALLET UNITS STACKED TWO HIGH, REDUCE SPEED AND DRIVE WITH EXTREME CARE DUE TO THE HIGHER CENTER OF GRAVITY FOR THE TWO HIGH LOAD. ALSO, WHERE PALLETS ARE STACKED, THE OVERALL HEIGHT OF THE LOADED VEHICLE MAY EXCEED 4 METERS, WHICH COULD RESTRICT MOVEMENT OVER CERTAIN ROADS WORLDWIDE.
11. IF PALLET UNITS ARE POSITIONED TWO WIDE WITH THE LENGTH PARALLEL TO THE SIDES OF THE TRUCK AND/OR FLATRACK AS SHOWN IN THE LOAD ON PAGE 20, IN LIEU OF ONE WIDE WITH THE WIDTH PARALLEL TO THE SIDES AS SHOWN IN THE LOAD ON PAGE 18, LESS WEB STRAP TIEDOWN ASSEMBLIES ARE REQUIRED TO SECURE THE LOAD.
12. WHEN LOADING LATERALLY ADJACENT PALLET UNITS ON THE HEMTT AND HEMAT ASSURE THAT THE TIEDOWN ANCHORS LOCATED ON EACH SIDE OF THE CARGO DECK ARE NOT COVERED BY THE PALLET BASE, AND THERE IS SUFFICIENT ROOM TO ATTACH THE WEB STRAPS.

(CONTINUED AT RIGHT)

INDEX (SEE "NOTE ⊕" AND "NOTE *" BELOW)

ITEM	PAGE(S)
GENERAL NOTES AND MATERIAL SPECIFICATIONS - - - - -	2
LOADING AND TIEDOWN PROCEDURES - - - - -	3
REARM FOR ONE APACHE HELICOPTER ON THE 5-TON M925A1 CARGO TRUCK - - - - -	4,5
REARM FOR ONE APACHE HELICOPTER ON THE 10-TON M977 AND/OR M985 HEMTT - - - - -	6,7
REARM FOR TWO APACHE HELICOPTERS ON THE 10-TON M977 AND/OR M985 HEMTT - - - - -	8,9
REARM FOR THREE APACHE HELICOPTERS ON THE 10-TON M977 AND/OR M985 HEMTT - - - - -	10,11
REARM FOR ONE APACHE HELICOPTER ON THE 11-TON M989A1 HEMAT - - - - -	12,13
REARM FOR TWO APACHE HELICOPTERS ON THE 11-TON M989A1 HEMAT - - - - -	14,15
REARM FOR THREE APACHE HELICOPTERS ON THE 11-TON M989A1 HEMAT - - - - -	16,17
REARM FOR ONE APACHE HELICOPTER ON THE 16-1/2-TON M1077 FLATRACK - - - - -	18,19
REARM FOR TWO APACHE HELICOPTERS ON THE M1 ISO COMPATIBLE PLS FLATRACK (IPF) - - - - -	20,21
REARM FOR THREE APACHE HELICOPTERS ON THE 16-1/2-TON M1077 FLATRACK - - - - -	22,23
REARM FOR FOUR APACHE HELICOPTERS ON THE 16-1/2-TON M1077 FLATRACK - - - - -	24,25
RATCHET/RATCHETING DETAILS - - - - -	26,27
PALLET UNIT DETAILS - - - - -	28
AUTHORIZED ARMAMENT CONFIGURATIONS FOR THE AH64 APACHE-	29
UNIVERSAL TIEDOWN ANCHOR DETAIL - - - - -	30

NOTE ⊕ :

ALL LOADS LISTED ON PAGES 18 THROUGH 25 IN THE INDEX ABOVE ARE DEPICTED ON THE M1077 FLATRACK WITH THE EXCEPTION OF THE LOAD ON PAGE 20 WHICH IS DEPICTED ON THE M1 FLATRACK. DUE TO ITS SHORTER LENGTH AND REDUCED LOAD WEIGHT, THE M1 FLATRACK CANNOT ALWAYS BE LOADED WITH THE SAME QUANTITY OF AMMUNITION AS THE M1077 FLATRACK. SEE GENERAL NOTE "Q" ON PAGE 2.

NOTE *:

THE TACTICAL VEHICLES LISTED IN THE INDEX ABOVE AND SHOWN WITHIN THIS DRAWING WERE SELECTED AS TYPICAL ONLY. OTHER TYPES OF VEHICLES MAY BE USED IN LIEU OF THOSE SHOWN AS LONG AS THEY COMPLY WITH GENERAL NOTE "C" ON PAGE 2.

(LOADING PROCEDURES CONTINUED)

13. ASSURE THAT ALL PALLET UNITS AND/OR OTHER ITEMS ARE POSITIONED TIGHTLY AGAINST EACH OTHER LATERALLY AND LONGITUDINALLY AS LOADING PROGRESSES. THIS WILL REDUCE LOAD MOVEMENT AND THE QUANTITY OF WEB STRAPS REQUIRED TO SECURE THE LOAD. VOID SPACES BETWEEN PALLET UNITS WILL FILL IN DURING TRANSPORT CAUSING WEB STRAPPING TO BECOME LOOSE.
14. DURING LONG HAULS, WHEN POSSIBLE, STRAPS SHOULD BE CHECKED DURING VEHICLE STOPS AND TIGHTENED, IF NECESSARY.
15. AFTER ALL LOADING PROCEDURES ARE COMPLETED, CHECK ALL WEB STRAPS FOR MAXIMUM TIGHTNESS AND RATCHET TIGHTER IF REQUIRED, PRIOR TO FOLDING UP AND TAPING THE LOOSE ENDS OF STRAPS AS INSTRUCTED IN GENERAL NOTE "F" ON PAGE 2.

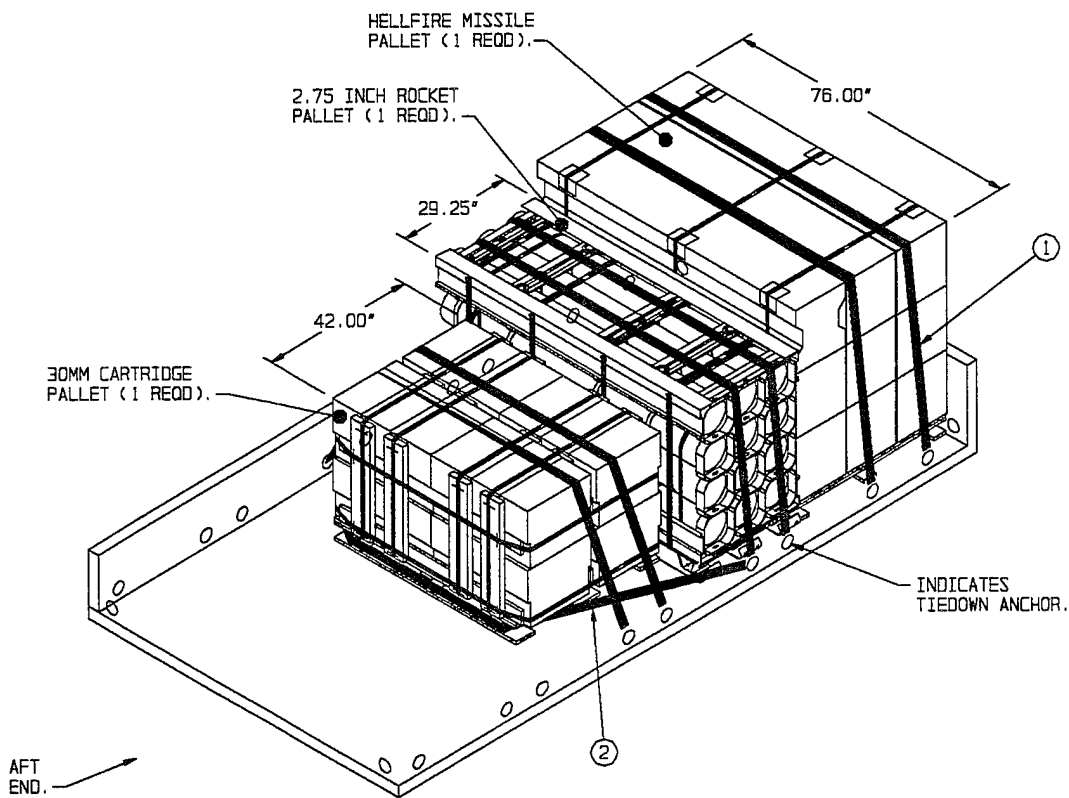

ISOMETRIC VIEW

KEY NUMBERS

- ① WEB STRAP TIEDOWN ASSEMBLY (6 REQD). INSTALL EACH STRAP TO EXTEND FROM A TIEDOWN ANCHOR ON SIDE OF TRUCK, OVER TOP OF PALLETS, TO A TIEDOWN ANCHOR ON OPPOSITE SIDE OF TRUCK. POSITION STRAP SCUFF SLEEVES AT SHARP EDGES. TAKE UP EXCESS SLACK IN STRAP AND THEN RATCHET TIGHT. SEE GENERAL NOTES "F" AND "G" ON PAGE 2 AND SPECIAL NOTE 6 ON PAGE 5.
- ② WEB STRAP TIEDOWN ASSEMBLY (1 REQD). INSTALL STRAP TO EXTEND FROM A TIEDOWN ANCHOR ON SIDE OF TRUCK, AROUND PALLET BASE AT AFT END OF LOAD, TO A TIEDOWN ANCHOR ON OPPOSITE SIDE OF TRUCK. POSITION STRAP SCUFF SLEEVES AT SHARP EDGES. TAKE UP EXCESS SLACK IN STRAP AND THEN RATCHET TIGHT. SEE GENERAL NOTES "F", "G", AND "N" ON PAGE 2.

REARM FOR ONE APACHE HELICOPTER

ITEM	ROUNDS REQD	ROUNDS PER PLT	PALLETS PER LOAD	ROUNDS PER LOAD	WEIGHT
30MM	1,200	2,904	1	2,904	3,208 LBS
HELLFIRE	8	9	1	9	1,749 LBS
2.75 INCH ROCKET	38	48	1	48	2,500 LBS
TOTAL			3		7,457 LBS

REARM FOR ONE APACHE HELICOPTER ON THE 5-TON M925A1 CARGO TRUCK

SPECIAL NOTES:

1. A REARM LOAD FOR ONE APACHE HELICOPTER IS SHOWN LOADED ON THE 5-TON M925A1 CARGO TRUCK HAVING CARGO AREA DIMENSIONS OF 168" LONG BY 88" WIDE AND A MAXIMUM LOAD WEIGHT OF 10,000 POUNDS.
2. IF LOADING PALLETIZED UNITS OF OTHER ITEMS, SIZES, OR QUANTITIES, FOLLOW THESE SAME PROCEDURES.
3. PRIOR TO LOADING THE PALLETIZED UNITS, ASSURE THAT ALL STEEL STRAPPING ON EACH PALLET IS IN POSITION AND IS TIGHT. MISSING AND/OR LOOSE STEEL STRAPPING SHOULD BE REPLACED.
4. POSITION THE LOAD TIGHT AGAINST THE FORWARD END WALL.
5. ALL PALLETS MUST BE POSITIONED TIGHTLY AGAINST EACH OTHER Laterally and Longitudinally. THIS WILL REDUCE LOAD MOVEMENT AND THE QUANTITY OF WEB STRAPS REQUIRED TO SECURE THE LOAD. VOID SPACES BETWEEN PALLET UNITS WILL FILL IN DURING TRANSPORT CAUSING WEB STRAPS TO BECOME LOOSE.
6. EACH LATERAL ROW OF ONE OR MORE PALLET UNITS MUST BE SECURED WITH TWO WEB STRAPS OVER THE TOP AS SHOWN. THESE TWO STRAPS MAY BE CROSSED AND/OR POSITIONED STRAIGHT ACROSS THE TOP OF A ROW.
7. FOR DETAILS OF THE PALLETIZED UNITS SHOWN IN THE LOAD ON PAGE 4, SEE PAGE 28 IN THIS DRAWING.
8. A TOTAL OF SEVEN WEB STRAP TIEDOWN ASSEMBLIES ARE REQUIRED FOR THE LOAD SHOWN.

LOAD AS SHOWN

<u>ITEM</u>	<u>QUANTITY</u>	<u>WEIGHT (APPROX)</u>
APACHE REARM - - - - -	1 - - - - -	7,457 LBS

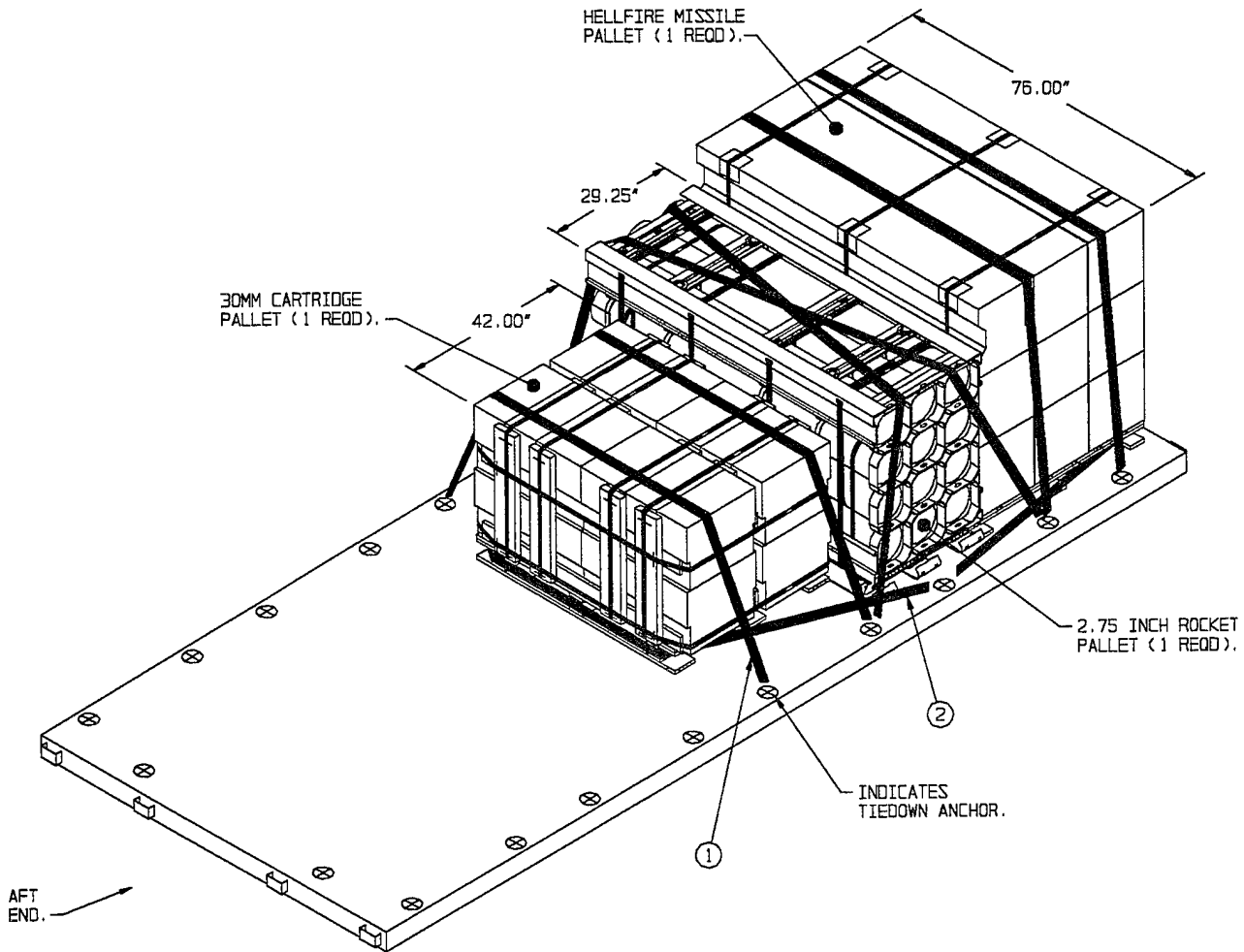

ISOMETRIC VIEW

KEY NUMBERS

- ① WEB STRAP TIEDOWN ASSEMBLY (6 REQD). INSTALL EACH STRAP TO EXTEND FROM A TIEDOWN ANCHOR ON SIDE OF TRUCK, OVER TOP OF PALLETS, TO A TIEDOWN ANCHOR ON OPPOSITE SIDE OF TRUCK. POSITION STRAP SCUFF SLEEVES AT SHARP EDGES. TAKE UP EXCESS SLACK IN STRAP AND THEN RATCHET TIGHT. SEE GENERAL NOTES "F" AND "G" ON PAGE 2 AND SPECIAL NOTE 6 ON PAGE 7.
- ② WEB STRAP TIEDOWN ASSEMBLY (2 REQD). INSTALL EACH STRAP TO EXTEND FROM A TIEDOWN ANCHOR ON SIDE OF TRUCK, AROUND PALLET BASE AT FORWARD AND AFT END OF LOAD, TO A TIEDOWN ANCHOR ON OPPOSITE SIDE OF TRUCK. POSITION STRAP SCUFF SLEEVES AT SHARP EDGES. TAKE UP EXCESS SLACK IN STRAP AND THEN RATCHET TIGHT. SEE GENERAL NOTES "F", "G", AND "N" ON PAGE 2.

REAM FOR ONE APACHE HELICOPTER					
ITEM	ROUNDS REQD	ROUNDS PER PLT	PALLETS PER LOAD	ROUNDS PER LOAD	WEIGHT
30MM	1,200	2,904	1	2,904	3,208 LBS
HELLFIRE	8	9	1	9	1,749 LBS
2.75 INCH ROCKET	38	48	1	48	2,500 LBS
TOTAL			3		7,457 LBS

SPECIAL NOTES:

1. A REARM LOAD FOR ONE APACHE HELICOPTER IS SHOWN LOADED ON THE 10-TON M977 AND/OR M985 HEAVY EXPANDED MOBILITY TACTICAL TRUCK (HEMTT) HAVING CARGO DECK DIMENSIONS OF 216-3/8" LONG BY 90-3/4" WIDE AND A MAXIMUM LOAD WEIGHT OF 22,000 POUNDS.
2. IF LOADING PALLETIZED UNITS OF OTHER ITEMS, SIZES, OR QUANTITIES, FOLLOW THESE SAME PROCEDURES.
3. PRIOR TO LOADING THE PALLETIZED UNITS, ASSURE THAT ALL STEEL STRAPPING ON EACH PALLET IS IN POSITION AND IS TIGHT. MISSING AND/OR LOOSE STEEL STRAPPING SHOULD BE REPLACED.
4. ALL PALLETS MUST BE POSITIONED TIGHTLY AGAINST EACH OTHER Laterally and Longitudinally. THIS WILL REDUCE LOAD MOVEMENT AND THE QUANTITY OF WEB STRAPS REQUIRED TO SECURE THE LOAD. VOID SPACES BETWEEN PALLET UNITS WILL FILL IN DURING TRANSPORT CAUSING WEB STRAPS TO BECOME LOOSE.
5. EACH LATERAL ROW OF ONE OR MORE PALLET UNITS MUST BE SECURED WITH TWO WEB STRAPS OVER THE TOP AS SHOWN. THESE TWO STRAPS MAY BE CROSSED AND/OR POSITIONED STRAIGHT ACROSS THE TOP OF A ROW.
6. FOR DETAILS OF THE PALLETIZED UNITS SHOWN IN THE LOAD ON PAGE 6, SEE PAGE 2B IN THIS DRAWING.
7. A TOTAL OF EIGHT WEB STRAP TIEDOWN ASSEMBLIES ARE REQUIRED FOR THE LOAD SHOWN.

LOAD AS SHOWN

<u>ITEM</u>	<u>QUANTITY</u>	<u>WEIGHT (APPROX)</u>
APACHE REARM - - - - -	1 - - - - -	7,457 LBS

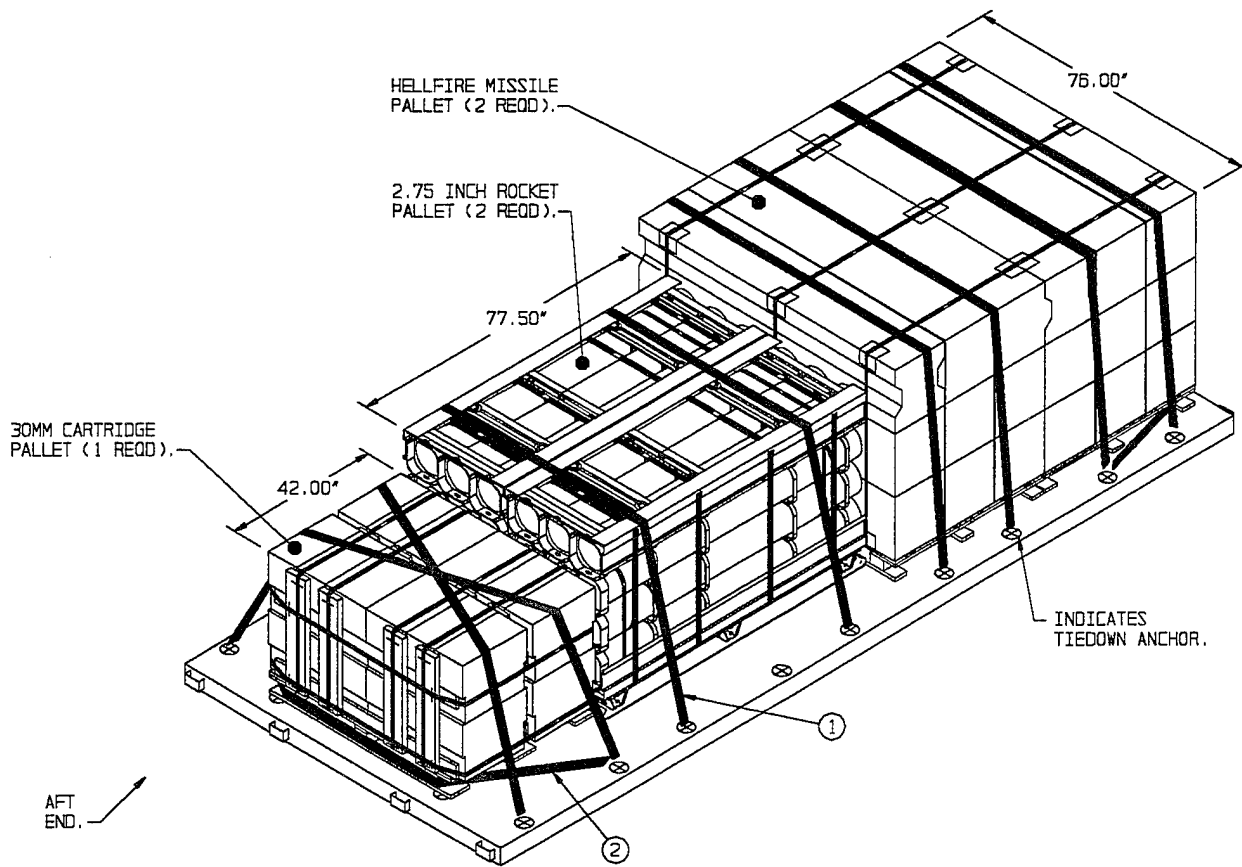

ISOMETRIC VIEW

KEY NUMBERS

- ① WEB STRAP TIEDOWN ASSEMBLY (8 REQD). INSTALL EACH STRAP TO EXTEND FROM A TIEDOWN ANCHOR ON SIDE OF TRUCK, OVER TOP OF PALLETS, TO A TIEDOWN ANCHOR ON OPPOSITE SIDE OF TRUCK. POSITION STRAP SCUFF SLEEVES AT SHARP EDGES. TAKE UP EXCESS SLACK IN STRAP AND THEN RATCHET TIGHT. SEE GENERAL NOTES "F" AND "G" ON PAGE 2 AND SPECIAL NOTE 6 ON PAGE 9.
- ② WEB STRAP TIEDOWN ASSEMBLY (2 REQD). INSTALL EACH STRAP TO EXTEND FROM A TIEDOWN ANCHOR ON SIDE OF TRUCK, AROUND PALLET BASE AT FORWARD AND AFT END OF LOAD, TO A TIEDOWN ANCHOR ON OPPOSITE SIDE OF TRUCK. POSITION STRAP SCUFF SLEEVES AT SHARP EDGES. TAKE UP EXCESS SLACK IN STRAP AND THEN RATCHET TIGHT. SEE GENERAL NOTES "F", "G", AND "N" ON PAGE 2.

REARM FOR TWO APACHE HELICOPTERS					
ITEM	ROUNDS REQD	ROUNDS PER PLT	PALLETS PER LOAD	ROUNDS PER LOAD	WEIGHT
30MM	2,400	2,904	1	2,904	3,208 LBS
HELLFIRE	16	9	2	18	3,498 LBS
2.75 INCH ROCKET	76	48	2	96	5,000 LBS
TOTAL			5		11,706 LBS

SPECIAL NOTES:

1. A REARM LOAD FOR TWO APACHE HELICOPTERS IS SHOWN LOADED ON THE 10-TON M977 AND/OR M985 HEAVY EXPANDED MOBILITY TACTICAL TRUCK (HEMTT) HAVING CARGO DECK DIMENSIONS OF 216-3/8" LONG BY 90-3/4" WIDE AND A MAXIMUM LOAD WEIGHT OF 22,000 POUNDS.
2. IF LOADING PALLETIZED UNITS OF OTHER ITEMS, SIZES, OR QUANTITIES, FOLLOW THESE SAME PROCEDURES.
3. PRIOR TO LOADING THE PALLETIZED UNITS, ASSURE THAT ALL STEEL STRAPPING ON EACH PALLET IS IN POSITION AND IS TIGHT. MISSING AND/OR LOOSE STEEL STRAPPING SHOULD BE REPLACED.
4. ALL PALLETS MUST BE POSITIONED TIGHTLY AGAINST EACH OTHER Laterally and Longitudinally. THIS WILL REDUCE LOAD MOVEMENT AND THE QUANTITY OF WEB STRAPS REQUIRED TO SECURE THE LOAD. VOID SPACES BETWEEN PALLET UNITS WILL FILL IN DURING TRANSPORT CAUSING WEB STRAPS TO BECOME LOOSE.
5. EACH LATERAL ROW OF ONE OR MORE PALLET UNITS MUST BE SECURED WITH TWO WEB STRAPS OVER THE TOP AS SHOWN. THESE TWO STRAPS MAY BE CROSSED AND/OR POSITIONED STRAIGHT ACROSS THE TOP OF A ROW.
6. FOR DETAILS OF THE PALLETIZED UNITS SHOWN IN THE LOAD ON PAGE 8, SEE PAGE 28 IN THIS DRAWING.
7. A TOTAL OF TEN WEB STRAP TIEDOWN ASSEMBLIES ARE REQUIRED FOR THE LOAD SHOWN.

LOAD AS SHOWN

<u>ITEM</u>	<u>QUANTITY</u>	<u>WEIGHT (APPROX)</u>
APACHE REARM - - - - -	2 - - - - -	11,706 LBS

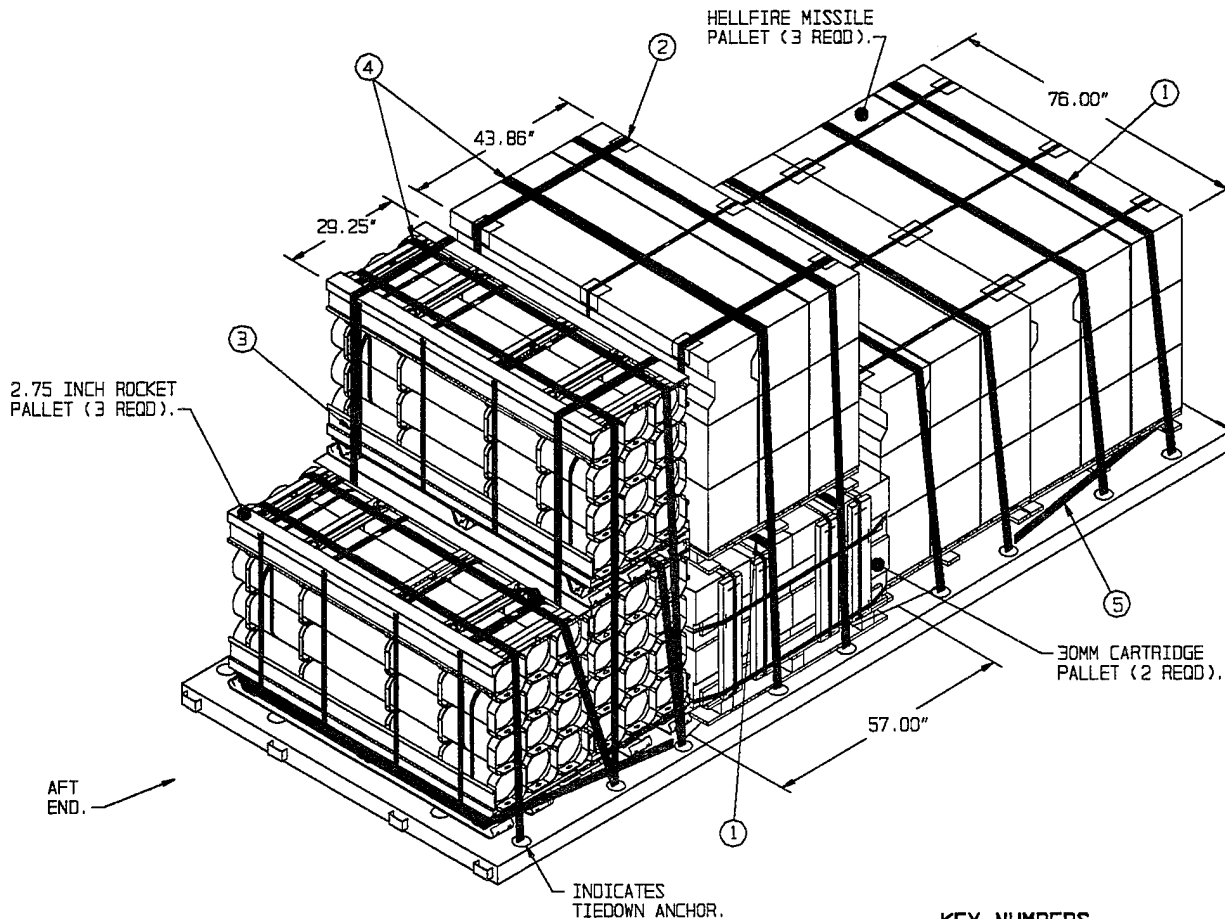

ISOMETRIC VIEW

CAUTION: LOAD HEIGHT IS 89.25" ABOVE CARGO DECK FLOOR. WHEN TRANSPORTING LOADS HAVING PALLET UNITS STACKED TWO HIGH REDUCE SPEED AND DRIVE CAUTIOUSLY DUE TO THE HIGHER CENTER OF GRAVITY AND POSSIBLE CLEARANCE LIMITATIONS.

KEY NUMBERS

- ① WEB STRAP TIEDOWN ASSEMBLY (9 REQD). INSTALL EACH STRAP TO EXTEND FROM A TIEDOWN ANCHOR ON SIDE OF TRUCK, OVER TOP OF ONE HIGH PALLET, TO A TIEDOWN ANCHOR ON OPPOSITE SIDE OF TRUCK. POSITION STRAP SCUFF SLEEVES AT SHARP EDGES. TAKE UP EXCESS SLACK IN STRAP AND THEN RATCHET TIGHT. SEE GENERAL NOTES "F" AND "G" ON PAGE 2.
- ② WEB STRAP TIEDOWN ASSEMBLY (2 REQD). HOOK TWO STRAPS TOGETHER AND ENCIRCLE THE 30MM CARTRIDGE PALLET AND THE HELLFIRE MISSILE PALLET AT TWO PLACES. POSITION STRAP SCUFF SLEEVES AT SHARP EDGES. TAKE UP EXCESS SLACK IN STRAP AND THEN RATCHET TIGHT. NOTE: THESE TWO STRAPS MUST BE PREPOSITIONED UNDER THE 30MM CARTRIDGE PALLETS AS LOADING PROGRESSES. SEE GENERAL NOTES "F", "G" AND "J" ON PAGE 2.
- ③ WEB STRAP TIEDOWN ASSEMBLY (2 REQD). HOOK TWO STRAPS TOGETHER AND ENCIRCLE THE TWO HIGH STACK OF 2.75 INCH ROCKET PALLETS AT TWO PLACES. POSITION STRAP SCUFF SLEEVES AT SHARP EDGES. TAKE UP EXCESS SLACK IN STRAP AND THEN RATCHET TIGHT. NOTE: THESE TWO STRAPS MUST BE PREPOSITIONED UNDER THE BOTTOM PALLET AS LOADING PROGRESSES. SEE GENERAL NOTES "F", "G" AND "J" ON PAGE 2.
- ④ WEB STRAP TIEDOWN ASSEMBLY (4 REQD). HOOK TWO STRAPS TOGETHER AND INSTALL EACH ASSEMBLY TO EXTEND FROM A TIEDOWN ANCHOR ON SIDE OF TRUCK, OVER TOP OF TWO HIGH PALLETS, TO A TIEDOWN ANCHOR ON THE OPPOSITE SIDE OF TRUCK. POSITION STRAP SCUFF SLEEVES AT SHARP EDGES. TAKE UP EXCESS SLACK IN STRAP AND THEN RATCHET TIGHT. SEE GENERAL NOTES "F", "G" AND "J" ON PAGE 2 AND SPECIAL NOTE 7 ON PAGE 11.
- ⑤ WEB STRAP TIEDOWN ASSEMBLY (2 REQD). INSTALL EACH STRAP TO EXTEND FROM A TIEDOWN ANCHOR ON SIDE OF TRUCK, AROUND PALLET BASES AT FORWARD AND AFT END OF LOAD, TO A TIEDOWN ANCHOR ON OPPOSITE SIDE OF TRUCK. POSITION STRAP SCUFF SLEEVES AT SHARP EDGES. TAKE UP EXCESS SLACK IN STRAP AND THEN RATCHET TIGHT. SEE GENERAL NOTES "F" AND "G" ON PAGE 2.

REARM FOR THREE APACHE HELICOPTERS

ITEM	ROUNDS REQD	ROUNDS PER PLT	PALLETS PER LOAD	ROUNDS PER LOAD	WEIGHT
30MM	3,600	2,904	2	5,808	6,416 LBS
HELLFIRE	24	9	3	27	5,247 LBS
2.75 INCH ROCKET	114	48	3	144	7,500 LBS
TOTAL			8		19,163 LBS

REARM FOR THREE APACHE HELICOPTERS ON THE 10-TON M977 AND/OR M985 HEMTT

SPECIAL NOTES:

1. A REARM LOAD FOR THREE APACHE HELICOPTERS IS SHOWN LOADED ON THE 10-TON M977 AND/OR M985 HEAVY EXPANDED MOBILITY TACTICAL TRUCK (HEMTT) HAVING CARGO DECK DIMENSIONS OF 216-3/8" LONG BY 90-3/4" WIDE AND A MAXIMUM LOAD WEIGHT OF 22,000 POUNDS.
2. IF LOADING PALLETIZED UNITS OF OTHER ITEMS, SIZES, OR QUANTITIES, FOLLOW THESE SAME PROCEDURES.
3. PRIOR TO LOADING THE PALLETIZED UNITS, ASSURE THAT ALL STEEL STRAPPING ON EACH PALLET IS IN POSITION AND IS TIGHT. MISSING AND/OR LOOSE STEEL STRAPPING SHOULD BE REPLACED.
4. ALL PALLETS MUST BE POSITIONED TIGHTLY AGAINST EACH OTHER Laterally and Longitudinally. THIS WILL REDUCE LOAD MOVEMENT AND THE QUANTITY OF WEB STRAPS REQUIRED TO SECURE THE LOAD. VOID SPACES BETWEEN PALLET UNITS WILL FILL IN DURING TRANSPORT CAUSING WEB STRAPS TO BECOME LOOSE.
5. WHEN POSITIONING THE HELLFIRE MISSILE PALLET ON TOP OF THE TWO 30MM CARTRIDGE PALLETS, ASSURE IT IS CENTERED Laterally and Longitudinally PRIOR TO POSITIONING AND TIGHTENING STRAPS MARKED ② AND ④.
6. EACH LATERAL ONE HIGH AND TWO HIGH ROW OF PALLET UNITS MUST BE SECURED WITH TWO WEB STRAPS OVER THE TOP AS SHOWN. THESE TWO STRAPS MAY BE CROSSED AND/OR POSITIONED STRAIGHT ACROSS THE TOP OF A ROW. THE BOTTOM PALLET IN A TWO HIGH STACK MUST HAVE A MINIMUM OF ONE STRAP OVER THE TOP.
7. FOR DETAILS OF THE PALLETIZED UNITS SHOWN IN THE LOAD ON PAGE 10, SEE PAGE 28 IN THIS DRAWING.
8. A TOTAL OF 27 WEB STRAP TIEDOWN ASSEMBLIES ARE REQUIRED FOR THE LOAD SHOWN.

LOAD AS SHOWN

<u>ITEM</u>	<u>QUANTITY</u>	<u>WEIGHT (APPROX)</u>
APACHE REARM - - - - -	3 - - - - -	19,163 LBS

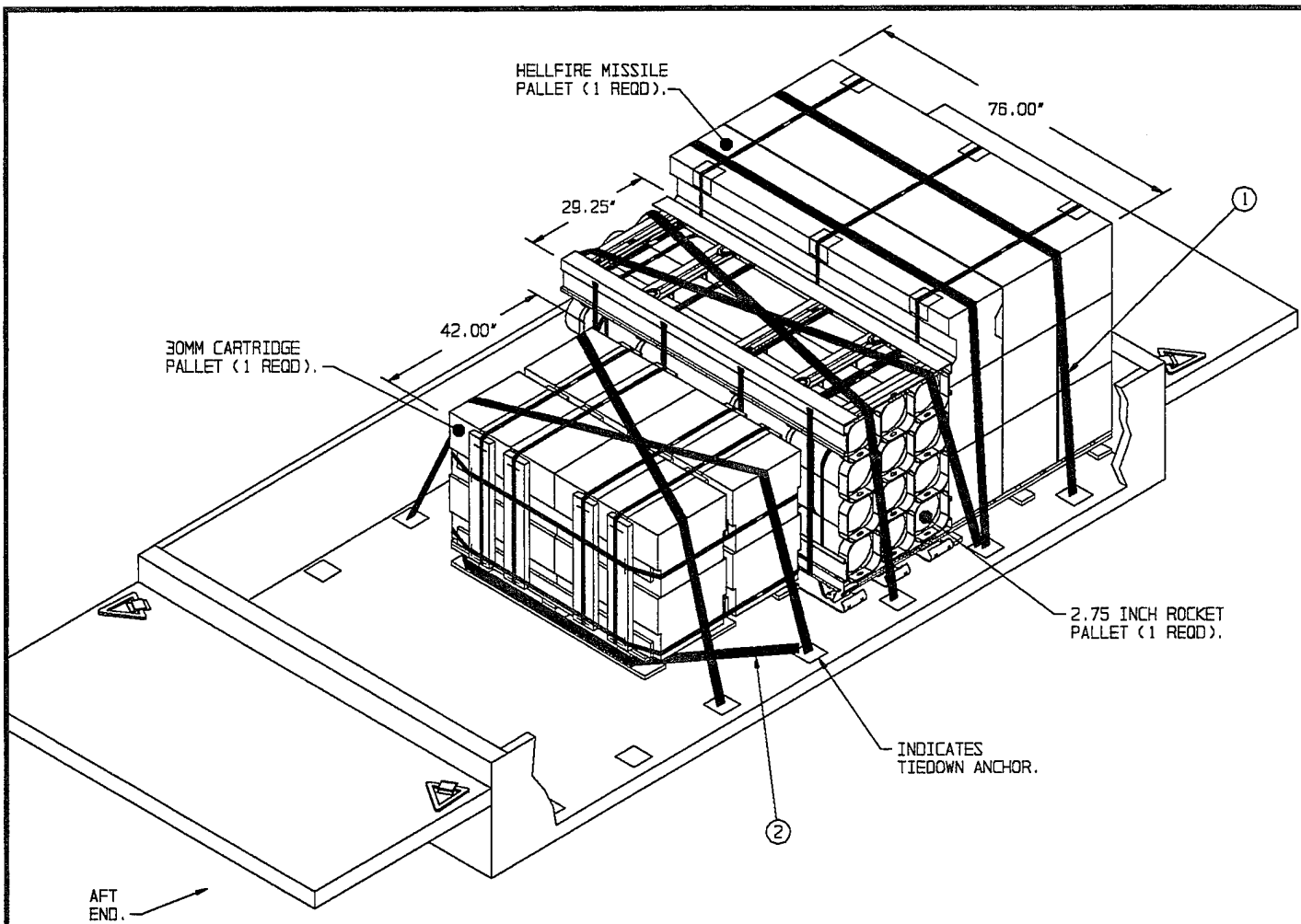

ISOMETRIC VIEW

KEY NUMBERS

- ① WEB STRAP TIEDOWN ASSEMBLY (6 REQD). INSTALL EACH STRAP TO EXTEND FROM A TIEDOWN ANCHOR ON SIDE OF TRAILER, OVER TOP OF PALLETS, TO A TIEDOWN ANCHOR ON OPPOSITE SIDE OF TRAILER. POSITION STRAP SCUFF SLEEVES AT SHARP EDGES. STAKE UP EXCESS SLACK IN STRAP AND THEN RATCHET TIGHT. SEE GENERAL NOTES "F" AND "G" ON PAGE 2 AND SPECIAL NOTE 6 ON PAGE 13.
- ② WEB STRAP TIEDOWN ASSEMBLY (1 REQD). INSTALL EACH STRAP TO EXTEND FROM A TIEDOWN ANCHOR ON SIDE OF TRAILER, AROUND PALLET BASE AT AFT END OF LOAD, TO A TIEDOWN ANCHOR ON OPPOSITE SIDE OF TRAILER. POSITION STRAP SCUFF SLEEVES AT SHARP EDGES. TAKE UP EXCESS SLACK IN STRAP AND THEN RATCHET TIGHT. SEE GENERAL NOTES "F", "G" AND "N" ON PAGE 2.

REARM FOR ONE APACHE HELICOPTER					
ITEM	ROUNDS REQD	ROUNDS PER PLT	PALLETS PER LOAD	ROUNDS PER LOAD	WEIGHT
30MM	1,200	2,904	1	2,904	3,208 LBS
HELLFIRE	8	9	1	9	1,749 LBS
2.75 INCH ROCKET	36	48	1	48	2,500 LBS
TOTAL			3		7,457 LBS

SPECIAL NOTES:

1. A REARM LOAD FOR ONE APACHE HELICOPTER IS SHOWN LOADED ON THE 11-TON M989A1 HEAVY EXPANDED MOBILITY AMMUNITION TRAILER (HEMAT) HAVING CARGO DECK DIMENSIONS OF 175" LONG BY 92" WIDE AND A MAXIMUM LOAD WEIGHT OF 22,000 POUNDS.
2. IF LOADING PALLETIZED UNITS OF OTHER ITEMS, SIZES, OR QUANTITIES, FOLLOW THESE SAME PROCEDURES.
3. PRIOR TO LOADING THE PALLETIZED UNITS, ASSURE THAT ALL STEEL STRAPPING ON EACH PALLET IS IN POSITION AND IS TIGHT. MISSING AND/OR LOOSE STEEL STRAPPING SHOULD BE REPLACED.
4. POSITION THE LOAD TIGHT AGAINST THE FORWARD END WALL.
5. ALL PALLETS MUST BE POSITIONED TIGHTLY AGAINST EACH OTHER Laterally and Longitudinally. THIS WILL REDUCE LOAD MOVEMENT AND THE QUANTITY OF WEB STRAPS REQUIRED TO SECURE THE LOAD. VOID SPACES BETWEEN PALLET UNITS WILL FILL IN DURING TRANSPORT CAUSING WEB STRAPS TO BECOME LOOSE.
6. EACH LATERAL ROW OF ONE OR MORE PALLET UNITS MUST BE SECURED WITH TWO WEB STRAPS OVER THE TOP AS SHOWN. THESE TWO STRAPS MAY BE CROSSED AND/OR POSITIONED STRAIGHT ACROSS THE TOP OF A ROW.
7. FOR DETAILS OF THE PALLETIZED UNITS SHOWN IN THE LOAD ON PAGE 12, SEE PAGE 28 IN THIS DRAWING.
8. A TOTAL OF SEVEN WEB STRAP TIEDOWN ASSEMBLIES ARE REQUIRED FOR THE LOAD SHOWN.

LOAD AS SHOWN

<u>ITEM</u>	<u>QUANTITY</u>	<u>WEIGHT (APPROX)</u>
APACHE REARM - - - - -	1 - - - - -	7,457 LBS

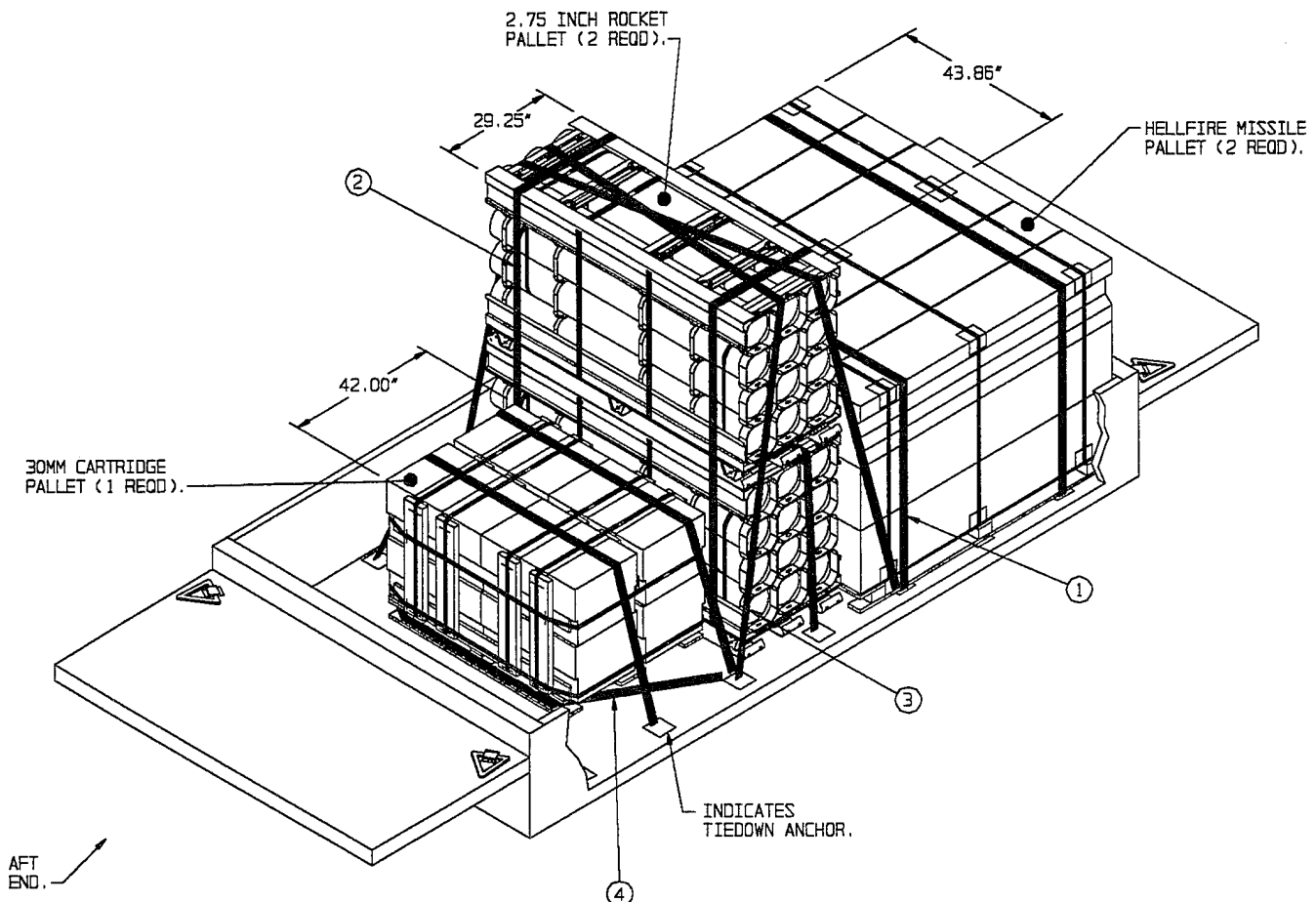

ISOMETRIC VIEW

CAUTION: LOAD HEIGHT IS 87" ABOVE CARGO DECK FLOOR. WHEN TRANSPORTING LOADS HAVING PALLET UNITS STACKED TWO HIGH REDUCE SPEED AND DRIVE CAUTIOUSLY DUE TO THE HIGHER CENTER OF GRAVITY AND POSSIBLE CLEARANCE LIMITATIONS.

KEY NUMBERS

- ① WEB STRAP TIEDOWN ASSEMBLY (5 REED). INSTALL EACH STRAP TO EXTEND FROM A TIEDOWN ANCHOR ON SIDE OF TRAILER, OVER TOP OF ONE HIGH PALLET, TO A TIEDOWN ANCHOR ON OPPOSITE SIDE OF TRAILER. POSITION STRAP SCUFF SLEEVES AT SHARP EDGES. TAKE UP EXCESS SLACK IN STRAP AND THEN RATCHET TIGHT. SEE GENERAL NOTES "F" AND "G" ON PAGE 2.
- ② WEB STRAP TIEDOWN ASSEMBLY (2 REED). HOOK TWO STRAPS TOGETHER AND ENIRCLE THE TWO HIGH STACK OF 2.75 INCH ROCKET PALLET AT TWO PLACES. POSITION STRAP SCUFF SLEEVES AT SHARP EDGES. TAKE UP EXCESS SLACK IN STRAP AND THEN RATCHET TIGHT. NOTE: THESE TWO STRAPS MUST BE PRE-POSITIONED UNDER THE BOTTOM PALLET AS LOADING PROGRESSES. SEE GENERAL NOTES "F", "G" AND "J" ON PAGE 2.
- ③ WEB STRAP TIEDOWN ASSEMBLY (2 REED). HOOK TWO STRAPS TOGETHER AND INSTALL EACH ASSEMBLY TO EXTEND FROM A TIEDOWN ANCHOR ON SIDE OF TRAILER OVER TOP OF TWO HIGH PALLET, TO A TIEDOWN ANCHOR ON THE OPPOSITE SIDE OF TRAILER. POSITION STRAP SCUFF SLEEVES AT SHARP EDGES. TAKE UP EXCESS SLACK IN STRAP AND THEN RATCHET TIGHT. SEE GENERAL NOTES "F", "G" AND "J" ON PAGE 2 AND SPECIAL NOTE 6 ON PAGE 15.
- ④ WEB STRAP TIEDOWN ASSEMBLY (1 REED). INSTALL STRAP TO EXTEND FROM A TIEDOWN ANCHOR ON SIDE OF TRAILER, AROUND PALLET BASE AT AFT END OF LOAD, TO A TIEDOWN ANCHOR ON OPPOSITE SIDE OF TRAILER. POSITION STRAP SCUFF SLEEVES AT SHARP EDGES. TAKE UP EXCESS SLACK IN STRAP AND THEN RATCHET TIGHT. SEE GENERAL NOTES "F" AND "G" ON PAGE 2.

REARM FOR TWO APACHE HELICOPTERS					
ITEM	ROUNDS REED	ROUNDS PER PLT	PALLETS PER LOAD	ROUNDS PER LOAD	WEIGHT
30MM	2,400	2,904	1	2,904	3,208 LBS
HELLFIRE	16	9	2	18	3,498 LBS
2.75 INCH ROCKET	76	48	2	96	5,000 LBS
TOTAL			5		11,706 LBS

SPECIAL NOTES:

1. A REARM LOAD FOR TWO APACHE HELICOPTERS IS SHOWN LOADED ON THE 11-TON M1989A1 HEAVY EXPANDED MOBILITY AMMUNITION TRAILER (HEMAT) HAVING CARGO DECK DIMENSIONS OF 175" LONG BY 92" WIDE AND A MAXIMUM LOAD WEIGHT OF 22,000 POUNDS.
2. IF LOADING PALLETIZED UNITS OF OTHER ITEMS, SIZES, OR QUANTITIES, FOLLOW THESE SAME PROCEDURES.
3. PRIOR TO LOADING THE PALLETIZED UNITS, ASSURE THAT ALL STEEL STRAPPING ON EACH PALLET IS IN POSITION AND IS TIGHT. MISSING AND/OR LOOSE STEEL STRAPPING SHOULD BE REPLACED.
4. POSITION THE LOAD TIGHT AGAINST THE FORWARD END WALL.
5. ALL PALLETES MUST BE POSITIONED TIGHTLY AGAINST EACH OTHER Laterally AND LONGITUDINALLY. THIS WILL REDUCE LOAD MOVEMENT AND THE QUANTITY OF WEB STRAPS REQUIRED TO SECURE THE LOAD. VOID SPACES BETWEEN PALLET UNITS WILL FILL IN DURING TRANSPORT CAUSING WEB STRAPS TO BECOME LOOSE.
6. EACH LATERAL ONE HIGH AND TWO HIGH ROW OF PALLET UNITS MUST BE SECURED WITH TWO WEB STRAPS OVER THE TOP AS SHOWN. THESE TWO STRAPS MAY BE CROSSED AND/OR POSITIONED STRAIGHT ACROSS THE TOP OF A ROW. THE BOTTOM PALLET IN A TWO HIGH STACK MUST HAVE A MINIMUM OF ONE STRAP OVER THE TOP.
7. FOR DETAILS OF THE PALLETIZED UNITS SHOWN IN THE LOAD ON PAGE 14, SEE PAGE 28 IN THIS DRAWING.
8. A TOTAL OF 14 WEB STRAP TIEDOWN ASSEMBLIES ARE REQUIRED FOR THE LOAD SHOWN.

LOAD AS SHOWN

<u>ITEM</u>	<u>QUANTITY</u>	<u>WEIGHT (APPROX)</u>
APACHE REARM	2	11,706 LBS

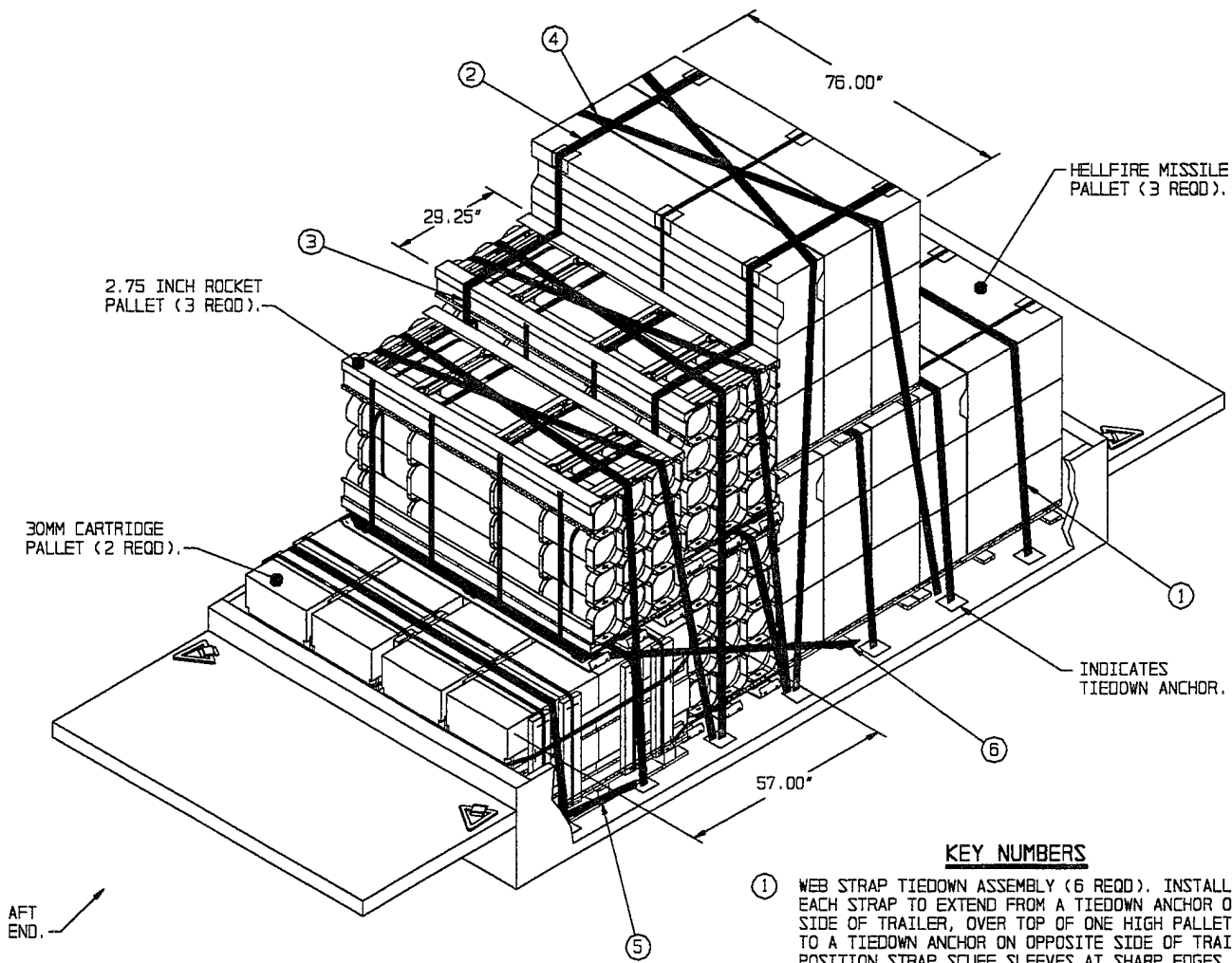

ISOMETRIC VIEW

CAUTION: LOAD HEIGHT IS 109" ABOVE CARGO DECK FLOOR. WHEN TRANSPORTING LOADS HAVING PALLET UNITS STACKED TWO HIGH REDUCE SPEED AND DRIVE CAUTIOUSLY DUE TO THE HIGHER CENTER OF GRAVITY AND POSSIBLE CLEARANCE LIMITATIONS.

KEY NUMBERS

- ① WEB STRAP TIEDOWN ASSEMBLY (6 REQD). INSTALL EACH STRAP TO EXTEND FROM A TIEDOWN ANCHOR ON SIDE OF TRAILER, OVER TOP OF ONE HIGH PALLET, TO A TIEDOWN ANCHOR ON OPPOSITE SIDE OF TRAILER. POSITION STRAP SCUFF SLEEVES AT SHARP EDGES. TAKE UP EXCESS SLACK IN STRAP AND THEN RATCHET TIGHT. SEE GENERAL NOTES "F" AND "G" ON PAGE 2.
- ② WEB STRAP TIEDOWN ASSEMBLY (2 REQD). HOOK TWO STRAPS TOGETHER AND ENCIRCLE THE TWO HIGH STACK OF HELLFIRE MISSILE PALLET AT TWO PLACES. POSITION STRAP SCUFF SLEEVES AT SHARP EDGES. TAKE UP EXCESS SLACK IN STRAP AND THEN RATCHET TIGHT. NOTE: THESE TWO STRAPS MUST BE PRE-POSITIONED UNDER THE BOTTOM PALLET AS LOADING PROGRESSES. SEE GENERAL NOTES "F", "G" AND "J" ON PAGE 2.
- ③ WEB STRAP TIEDOWN ASSEMBLY (2 REQD). HOOK TWO STRAPS TOGETHER AND ENCIRCLE THE TWO HIGH STACK OF 2.75 INCH ROCKET PALLET AT TWO PLACES. POSITION STRAP SCUFF SLEEVES AT SHARP EDGES. TAKE UP EXCESS SLACK IN STRAP AND THEN RATCHET TIGHT. NOTE: THESE TWO STRAPS MUST BE PRE-POSITIONED UNDER THE BOTTOM PALLET AS LOADING PROGRESSES. SEE GENERAL NOTES "F", "G" AND "J" ON PAGE 2.
- ④ WEB STRAP TIEDOWN ASSEMBLY (6 REQD). HOOK TWO STRAPS TOGETHER AND INSTALL EACH ASSEMBLY TO EXTEND FROM A TIEDOWN ANCHOR ON SIDE OF TRAILER, OVER TOP OF TWO HIGH PALLET, TO A TIEDOWN ANCHOR ON THE OPPOSITE SIDE OF TRAILER. POSITION STRAP SCUFF SLEEVES AT SHARP EDGES. TAKE UP EXCESS SLACK IN STRAP AND THEN RATCHET TIGHT. SEE GENERAL NOTES "F", "G" AND "J" ON PAGE 2 AND SPECIAL NOTE 7 ON PAGE 17.
- ⑤ WEB STRAP TIEDOWN ASSEMBLY (1 REQD). INSTALL STRAP TO EXTEND FROM A TIEDOWN ANCHOR ON SIDE OF TRAILER, AROUND PALLET BASES AT AFT END OF LOAD, TO A TIEDOWN ANCHOR ON OPPOSITE SIDE OF TRAILER. POSITION STRAP SCUFF SLEEVES AT SHARP EDGES. TAKE UP EXCESS SLACK IN STRAP AND THEN RATCHET TIGHT. SEE GENERAL NOTES "F" AND "G" ON PAGE 2.

REARM FOR THREE APACHE HELICOPTERS

ITEM	ROUNDS REQD	ROUNDS PER PLT	PALLETS PER LOAD	ROUNDS PER LOAD	WEIGHT
30MM	3,600	2,904	2	5,808	6,416 LBS
HELLFIRE	24	9	3	27	5,247 LBS
2.75 INCH ROCKET	114	48	3	144	7,500 LBS
TOTAL			8		19,163 LBS

(KEY NUMBERS CONTINUED)

- ⑥ WEB STRAP TIEDOWN ASSEMBLY (1 REQD). HOOK TWO STRAPS TOGETHER AND INSTALL TO EXTEND FROM A TIEDOWN ANCHOR ON SIDE OF TRAILER, AROUND PALLET BASE OF SECOND LAYER 2.75 INCH ROCKET PALLET, TO A TIEDOWN ANCHOR ON OPPOSITE SIDE OF TRAILER. POSITION STRAP SCUFF SLEEVES AT SHARP EDGES. TAKE UP EXCESS SLACK IN STRAP AND THEN RATCHET TIGHT. SEE GENERAL NOTES "F", "G", "J" AND "N" ON PAGE 2.

(CONTINUED AT LEFT)

SPECIAL NOTES:

1. A REARM LOAD FOR THREE APACHE HELICOPTERS IS SHOWN LOADED ON THE 11-TON M989A1 HEAVY EXPANDED MOBILITY AMMUNITION TRAILER (HEMAT) HAVING CARGO AREA DIMENSIONS OF 175' LONG BY 92' WIDE AND A MAXIMUM LOAD WEIGHT OF 22,000 POUNDS.
2. IF LOADING PALLETIZED UNITS OF OTHER ITEMS, SIZES, OR QUANTITIES, FOLLOW THESE SAME PROCEDURES.
3. PRIOR TO LOADING THE PALLETIZED UNITS, ASSURE THAT ALL STEEL STRAPPING ON EACH PALLET IS IN POSITION AND IS TIGHT. MISSING AND/OR LOOSE STEEL STRAPPING SHOULD BE REPLACED.
4. POSITION THE LOAD TIGHT AGAINST THE FORWARD END WALL.
5. ALL PALLETS MUST BE POSITIONED TIGHTLY AGAINST EACH OTHER Laterally and Longitudinally. THIS WILL REDUCE LOAD MOVEMENT AND THE QUANTITY OF WEB STRAPS REQUIRED TO SECURE THE LOAD. VOID SPACES BETWEEN PALLET UNITS WILL FILL IN DURING TRANSPORT CAUSING WEB STRAPS TO BECOME LOOSE.
6. WHEN POSITIONING THE 2.75 INCH ROCKET PALLET ON TOP OF THE TWO 30MM CARTRIDGE PALLETS, ASSURE IT IS CENTERED Laterally AND TIGHT AGAINST THE TWO HIGH STACK OF 2.75 INCH ROCKET PALLETS PRIOR TO POSITIONING AND TIGHTENING STRAPS MARKED ④ AND ⑤.
7. EACH LATERAL ONE HIGH AND TWO HIGH ROW OF PALLET UNITS MUST BE SECURED WITH TWO WEB STRAPS OVER THE TOP AS SHOWN. THESE TWO STRAPS MAY BE CROSSED AND/OR POSITIONED STRAIGHT ACROSS THE TOP OF A ROW. THE BOTTOM PALLET IN TWO HIGH STACK MUST HAVE A MINIMUM OF ONE STRAP OVER THE TOP.
8. FOR DETAILS OF THE PALLETIZED UNITS SHOWN IN THE LOAD ON PAGE 16, SEE PAGE 28 IN THIS DRAWING.
9. A TOTAL OF 29 WEB STRAP TIEDOWN ASSEMBLIES ARE REQUIRED FOR THE LOAD SHOWN.

LOAD AS SHOWN

<u>ITEM</u>	<u>QUANTITY</u>	<u>WEIGHT (APPROX)</u>
APACHE REARM - - - - -	3 - - - - -	19,163 LBS

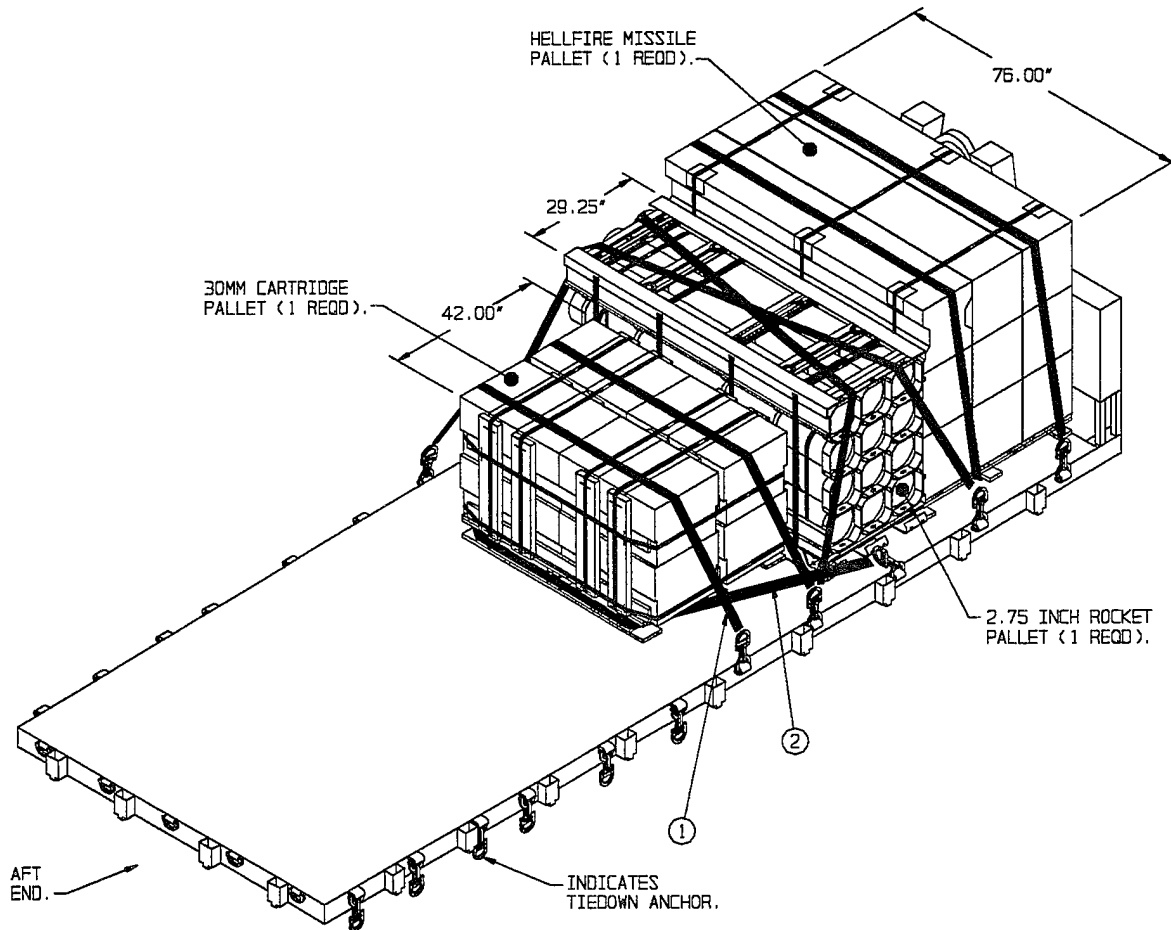

ISOMETRIC VIEW

KEY NUMBERS

- ① WEB STRAP TIEDOWN ASSEMBLY (6 REQD). INSTALL EACH STRAP TO EXTEND FROM A TIEDOWN ANCHOR ON SIDE OF FLATRACK, OVER TOP OF PALLETS, TO A TIEDOWN ANCHOR ON OPPOSITE SIDE OF FLATRACK. POSITION STRAP SCUFF SLEEVES AT SHARP EDGES. TAKE UP EXCESS SLACK IN STRAP AND THEN RATCHET TIGHT. SEE GENERAL NOTES "F", "G" AND "N" ON PAGE 2 AND SPECIAL NOTE 7 ON PAGE 19.
- ② WEB STRAP TIEDOWN ASSEMBLY (1 REQD). INSTALL STRAP TO EXTEND FROM A TIEDOWN ANCHOR ON SIDE OF FLATRACK, AROUND PALLET BASE AT AFT END OF LOAD, TO A TIEDOWN ANCHOR ON OPPOSITE SIDE OF FLATRACK. POSITION STRAP SCUFF SLEEVES AT SHARP EDGES. TAKE UP EXCESS SLACK IN STRAP AND THEN RATCHET TIGHT. SEE GENERAL NOTES "F" AND "G" ON PAGE 2.

REARM FOR ONE APACHE HELICOPTER					
ITEM	ROUNDS REQD	ROUNDS PER PLT	PALLETS PER LOAD	ROUNDS PER LOAD	WEIGHT
30MM	1,200	2,904	1	2,904	3,208 LBS
HELLFIRE	8	9	1	9	1,749 LBS
2.75 INCH ROCKET	38	48	1	48	2,500 LBS
TOTAL			3		7,457 LBS

SPECIAL NOTES:

1. A REARM LOAD FOR ONE APACHE HELICOPTER IS SHOWN LOADED ON THE 16-1/2-TON M1077 A-FRAME FLATRACK HAVING CARGO DECK DIMENSIONS OF 228" LONG BY 90-1/2" WIDE AND A MAXIMUM LOAD WEIGHT OF 33,000 POUNDS.
2. THE LOAD AS SHOWN ON PAGE 18 MAY ALSO BE LOADED ON THE M1 FLATRACK. SEE GENERAL NOTE "Q" ON PAGE 2.
3. IF LOADING PALLETIZED UNITS OF OTHER ITEMS, SIZES, OR QUANTITIES, FOLLOW THESE SAME PROCEDURES.
4. PRIOR TO LOADING THE PALLETIZED UNITS, ASSURE THAT ALL STEEL STRAPPING ON EACH PALLET IS IN POSITION AND IS TIGHT. MISSING AND/OR LOOSE STEEL STRAPPING SHOULD BE REPLACED.
5. POSITION THE LOAD TIGHT AGAINST THE A-FRAME AT THE FORWARD END OF THE FLATRACK.
6. ALL PALLETS MUST BE POSITIONED TIGHTLY AGAINST EACH OTHER Laterally and longitudinally. THIS WILL REDUCE LOAD MOVEMENT AND THE QUANTITY OF WEB STRAPS REQUIRED TO SECURE THE LOAD. VOID SPACES BETWEEN PALLET UNITS WILL FILL IN DURING TRANSPORT CAUSING WEB STRAPS TO BECOME LOOSE.
7. EACH LATERAL ROW OF ONE OR MORE PALLET UNITS MUST BE SECURED WITH TWO WEB STRAPS OVER THE TOP AS SHOWN. THESE TWO STRAPS MAY BE CROSSED AND/OR POSITIONED STRAIGHT ACROSS THE TOP OF A ROW.
8. FOR DETAILS OF THE PALLETIZED UNITS SHOWN IN THE LOAD ON PAGE 18, SEE PAGE 28 IN THIS DRAWING.
9. A TOTAL OF SEVEN WEB STRAP TIEDOWN ASSEMBLIES ARE REQUIRED FOR THE LOAD SHOWN.

LOAD AS SHOWN

<u>ITEM</u>	<u>QUANTITY</u>	<u>WEIGHT (APPROX)</u>
APACHE REARM	----- 1 -----	7,457 LBS

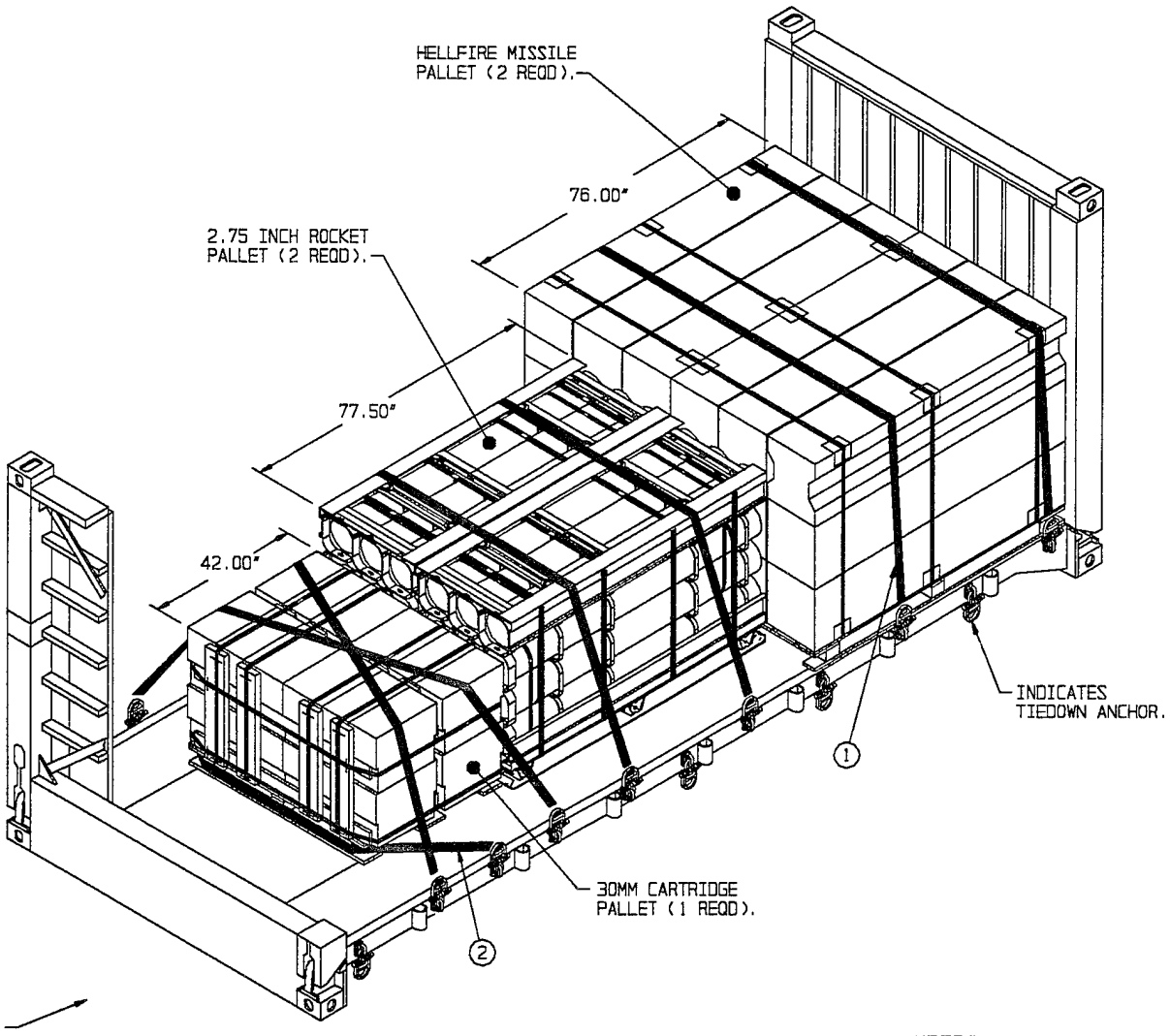

ISOMETRIC VIEW

KEY NUMBERS

- ① WEB STRAP TIEDOWN ASSEMBLY (6 REQD). INSTALL EACH STRAP TO EXTEND FROM A TIEDOWN ANCHOR ON SIDE OF FLATRACK, OVER TOP OF PALLETS, TO A TIEDOWN ANCHOR ON OPPOSITE SIDE OF FLATRACK. POSITION STRAP SCUFF SLEEVES AT SHARP EDGES. TAKE UP EXCESS SLACK IN STRAP AND THEN RATCHET TIGHT. SEE GENERAL NOTES "F" AND "G" ON PAGE 2 AND SPECIAL NOTE 7 ON PAGE 21.
- ② WEB STRAP TIEDOWN ASSEMBLY (1 REQD). INSTALL STRAP TO EXTEND FROM A TIEDOWN ANCHOR ON SIDE OF FLATRACK, AROUND PALLET BASE AT AFT END OF LOAD, TO A TIEDOWN ANCHOR ON OPPOSITE SIDE OF FLATRACK. POSITION STRAP SCUFF SLEEVES AT SHARP EDGES. TAKE UP EXCESS SLACK IN STRAP AND THEN RATCHET TIGHT. SEE GENERAL NOTES "F" AND "G" ON PAGE 2.

REARM FOR TWO APACHE HELICOPTERS					
ITEM	ROUNDS REQD	ROUNDS PER PLT	PALLETS PER LOAD	ROUNDS PER LOAD	WEIGHT
30MM	2,400	2,904	1	2,904	3,208 LBS
HELLFIRE	16	9	2	18	3,498 LBS
2.75 INCH ROCKET	76	48	2	96	5,000 LBS
TOTAL			5		11,706 LBS

SPECIAL NOTES:

1. A REARM LOAD FOR TWO APACHE HELICOPTERS IS SHOWN LOADED ON THE M1 FLATRACK HAVING CARGO DECK DIMENSIONS OF 222" LONG BY 90-1/2" WIDE AND A MAXIMUM LOAD WEIGHT OF 28,750 POUNDS.
2. THE LOAD AS SHOWN ON PAGE 20 MAY ALSO BE LOADED ON AN M1077 FLATRACK. SEE GENERAL NOTE "Q" ON PAGE 2.
3. IF LOADING PALLETIZED UNITS OF OTHER ITEMS, SIZES, OR QUANTITIES, FOLLOW THESE SAME PROCEDURES.
4. PRIOR TO LOADING THE PALLETIZED UNITS, ASSURE THAT ALL STEEL STRAPPING ON EACH PALLET IS IN POSITION AND IS TIGHT. MISSING AND/OR LOOSE STEEL STRAPPING SHOULD BE REPLACED.
5. POSITION THE LOAD TIGHT AGAINST THE FORWARD END WALL ON THE FLATRACK.
6. ALL PALLETS MUST BE POSITIONED TIGHTLY AGAINST EACH OTHER Laterally and Longitudinally. THIS WILL REDUCE LOAD MOVEMENT AND THE QUANTITY OF WEB STRAPS REQUIRED TO SECURE THE LOAD. VOID SPACES BETWEEN PALLET UNITS WILL FILL IN DURING TRANSPORT CAUSING WEB STRAPS TO BECOME LOOSE.
7. EACH LATERAL ROW OF ONE OR MORE PALLET UNITS MUST BE SECURED WITH TWO WEB STRAPS OVER THE TOP AS SHOWN. THESE TWO STRAPS MAY BE CROSSED AND/OR POSITIONED STRAIGHT ACROSS THE TOP OF A ROW.
8. FOR DETAILS OF THE PALLETIZED UNITS SHOWN IN THE LOAD ON PAGE 20, SEE PAGE 28 IN THIS DRAWING.
9. A TOTAL OF SEVEN WEB STRAP TIEDOWN ASSEMBLIES ARE REQUIRED FOR THE LOAD SHOWN.

LOAD AS SHOWN

<u>ITEM</u>	<u>QUANTITY</u>	<u>WEIGHT (APPROX)</u>
APACHE REARM	----- 2 -----	11,706 LBS

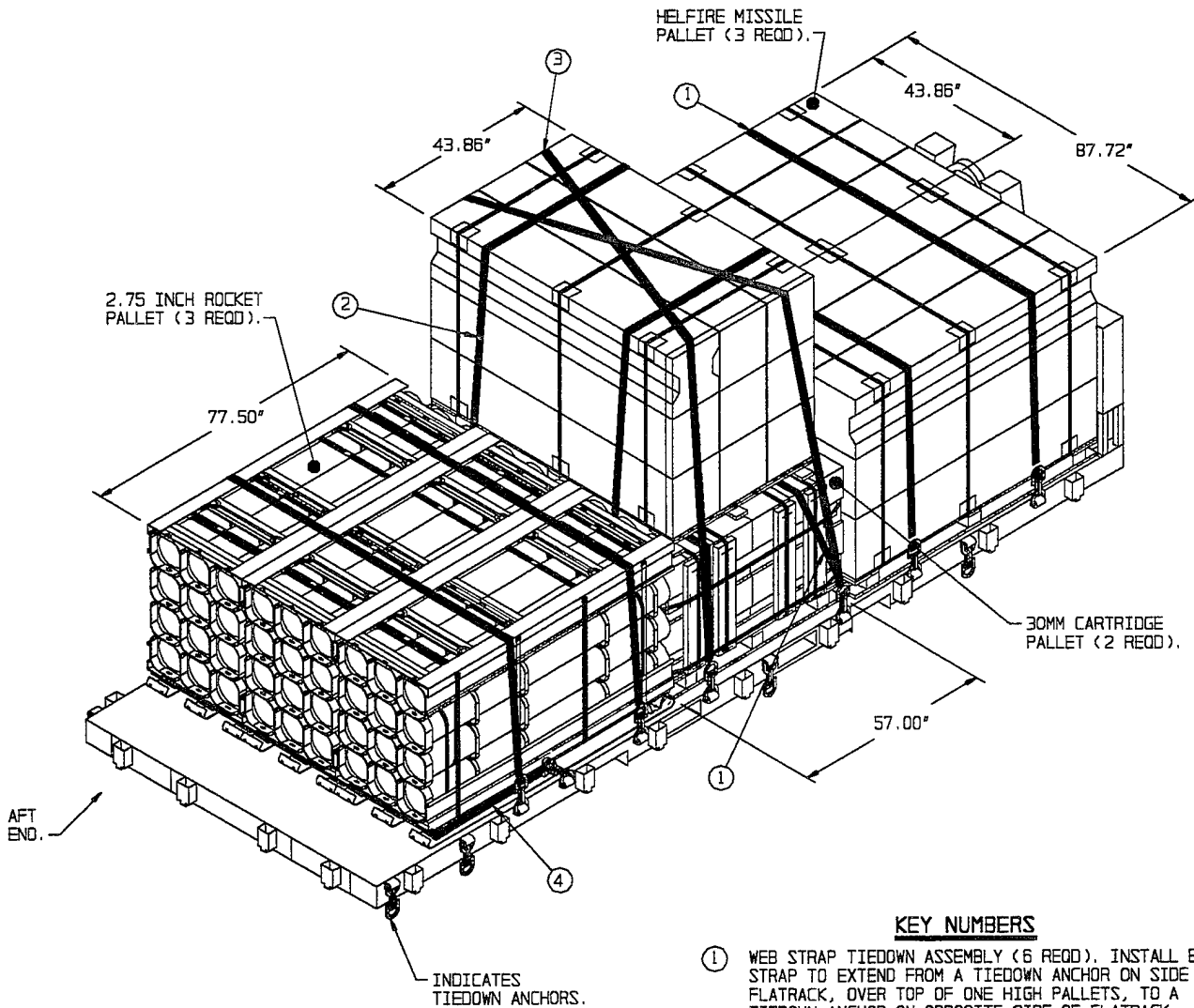

ISOMETRIC VIEW

CAUTION: LOAD HEIGHT IS 89.25" ABOVE CARGO DECK FLOOR. WHEN TRANSPORTING LOADS HAVING PALLET UNITS STACKED TWO HIGH REDUCE SPEED AND DRIVE CAUTIOUSLY DUE TO THE HIGHER CENTER OF GRAVITY AND POSSIBLE CLEARANCE LIMITATIONS.

KEY NUMBERS

- ① WEB STRAP TIEDOWN ASSEMBLY (6 REQD). INSTALL EACH STRAP TO EXTEND FROM A TIEDOWN ANCHOR ON SIDE OF FLATRACK, OVER TOP OF ONE HIGH PALLET, TO A TIEDOWN ANCHOR ON OPPOSITE SIDE OF FLATRACK. POSITION STRAP SCUFF SLEEVES AT SHARP EDGES. TAKE UP EXCESS SLACK IN STRAP AND THEN RATCHET TIGHT. SEE GENERAL NOTES "F" AND "G" ON PAGE 2 AND SPECIAL NOTE 8 ON PAGE 23.
- ② WEB STRAP TIEDOWN ASSEMBLY (2 REQD). HOOK TWO STRAPS TOGETHER AND ENCIRCLE THE 30MM CARTRIDGE PALLET AND THE HELLFIRE MISSILE PALLET AT TWO PLACES. POSITION STRAP SCUFF SLEEVES AT SHARP EDGES. TAKE UP EXCESS SLACK IN STRAP AND THEN RATCHET TIGHT. NOTE: THESE TWO STRAPS MUST BE PRE-POSITIONED UNDER THE 30MM CARTRIDGE PALLET AS LOADING PROGRESSES. SEE GENERAL NOTES "F", "G" AND "J" ON PAGE 2.
- ③ WEB STRAP TIEDOWN ASSEMBLY (2 REQD). HOOK TWO STRAPS TOGETHER AND INSTALL EACH ASSEMBLY TO EXTEND FROM A TIEDOWN ANCHOR ON SIDE OF FLATRACK, OVER TOP OF THE HELLFIRE MISSILE PALLET, TO A TIEDOWN ANCHOR ON OPPOSITE SIDE OF FLATRACK. POSITION STRAP SCUFF SLEEVES AT SHARP EDGES. TAKE UP EXCESS SLACK IN STRAP AND THEN RATCHET TIGHT. SEE GENERAL NOTES "F", "G", "J" AND "N" ON PAGE 2.
- ④ WEB STRAP TIEDOWN ASSEMBLY (1 REQD). INSTALL STRAP TO EXTEND FROM A TIEDOWN ANCHOR ON SIDE OF FLATRACK, AROUND PALLET BASES AT AFT END OF LOAD, TO A TIEDOWN ANCHOR ON OPPOSITE SIDE OF FLATRACK. POSITION STRAP SCUFF SLEEVES AT SHARP EDGES. TAKE UP EXCESS SLACK IN STRAP AND THEN RATCHET TIGHT. SEE GENERAL NOTES "F" AND "G" ON PAGE 2.

REARM FOR THREE APACHE HELICOPTERS

ITEM	ROUNDS REQD	ROUNDS PER PLT	PALLETS PER LOAD	ROUNDS PER LOAD	WEIGHT
30MM	3,600	2,904	2	5,808	6,416 LBS
HELLFIRE	24	9	3	27	5,247 LBS
2.75 INCH ROCKET	114	48	3	144	7,500 LBS
TOTAL			8		19,163 LBS

SPECIAL NOTES:

1. A REARM LOAD FOR THREE APACHE HELICOPTERS IS SHOWN LOADED ON THE M1077 A-FRAME FLATRACK HAVING CARGO DECK DIMENSIONS OF 228" LONG BY 90-1/2" WIDE AND A MAXIMUM LOAD WEIGHT OF 33,000 POUNDS.
2. THE LOAD AS SHOWN ON PAGE 22 MAY BE ALSO BE LOADED ON THE M1 FLATRACK. SEE GENERAL NOTE "Q" ON PAGE 2.
3. IF LOADING PALLETIZED UNITS OF OTHER ITEMS, SIZES, OR QUANTITIES, FOLLOW THESE SAME PROCEDURES.
4. PRIOR TO LOADING THE PALLETIZED UNITS, ASSURE THAT ALL STEEL STRAPPING ON EACH PALLET IS IN POSITION AND IS TIGHT. MISSING AND/OR LOOSE STEEL STRAPPING SHOULD BE REPLACED.
5. POSITION THE LOAD TIGHTLY AGAINST THE A-FRAME AT THE FORWARD END OF THE FLATRACK.
6. ALL PALLETES MUST BE POSITIONED TIGHTLY AGAINST EACH OTHER Laterally AND LONGITUDINALLY. THIS WILL REDUCE LOAD MOVEMENT AND THE QUANTITY OF WEB STRAPS REQUIRED TO SECURE THE LOAD. VOID SPACES BETWEEN PALLET UNITS WILL FILL IN DURING TRANSPORT CAUSING WEB STRAPS TO BECOME LOOSE.
7. WHEN POSITIONING THE HELLFIRE MISSILE PALLET ON TOP OF THE TWO 30MM CARTRIDGE PALLETES, ASSURE IT IS CENTERED Laterally AND LONGITUDINALLY PRIOR TO POSITIONING AND TIGHTENING STRAPS MARKED ② AND ③.
8. EACH LATERAL ONE HIGH AND TWO HIGH ROW OF PALLET UNITS MUST BE SECURED WITH TWO WEB STRAPS OVER THE TOP AS SHOWN. THESE TWO STRAPS MAY BE CROSSED AND/OR POSITIONED STRAIGHT ACROSS THE TOP OF A ROW. THE BOTTOM PALLET IN A TWO HIGH STACK HAVING A DIFFERENT PALLET ON TOP MUST HAVE TWO STRAPS OVER THE TOP AS SHOWN.
9. FOR DETAILS OF THE PALLETIZED UNITS SHOWN IN THE LOAD ON PAGE 22, SEE PAGE 28 IN THIS DRAWING.
10. A TOTAL OF 15 WEB STRAP TIEDOWN ASSEMBLIES ARE REQUIRED FOR THE LOAD SHOWN.

LOAD AS SHOWN

<u>ITEM</u>	<u>QUANTITY</u>	<u>WEIGHT (APPROX)</u>
APACHE REARM - - - - -	3 - - - - -	19,163 LBS

(KEY NUMBERS CONTINUED)

- ⑥ WEB STRAP TIEDOWN ASSEMBLY (1 REQD). HOOK TWO STRAPS TOGETHER AND INSTALL TO EXTEND FROM A TIEDOWN ANCHOR ON SIDE OF TRAILER, AROUND PALLET BASE OF SECOND LAYER 2.75 INCH ROCKET PALLET, TO A TIEDOWN ANCHOR ON OPPOSITE SIDE OF TRAILER. POSITION STRAP SCUFF SLEEVES AT SHARP EDGES. TAKE UP EXCESS SLACK IN STRAP AND THEN RATCHET TIGHT. SEE GENERAL NOTES "F", "G", "J" AND "N" ON PAGE 2.

(CONTINUED BELOW)

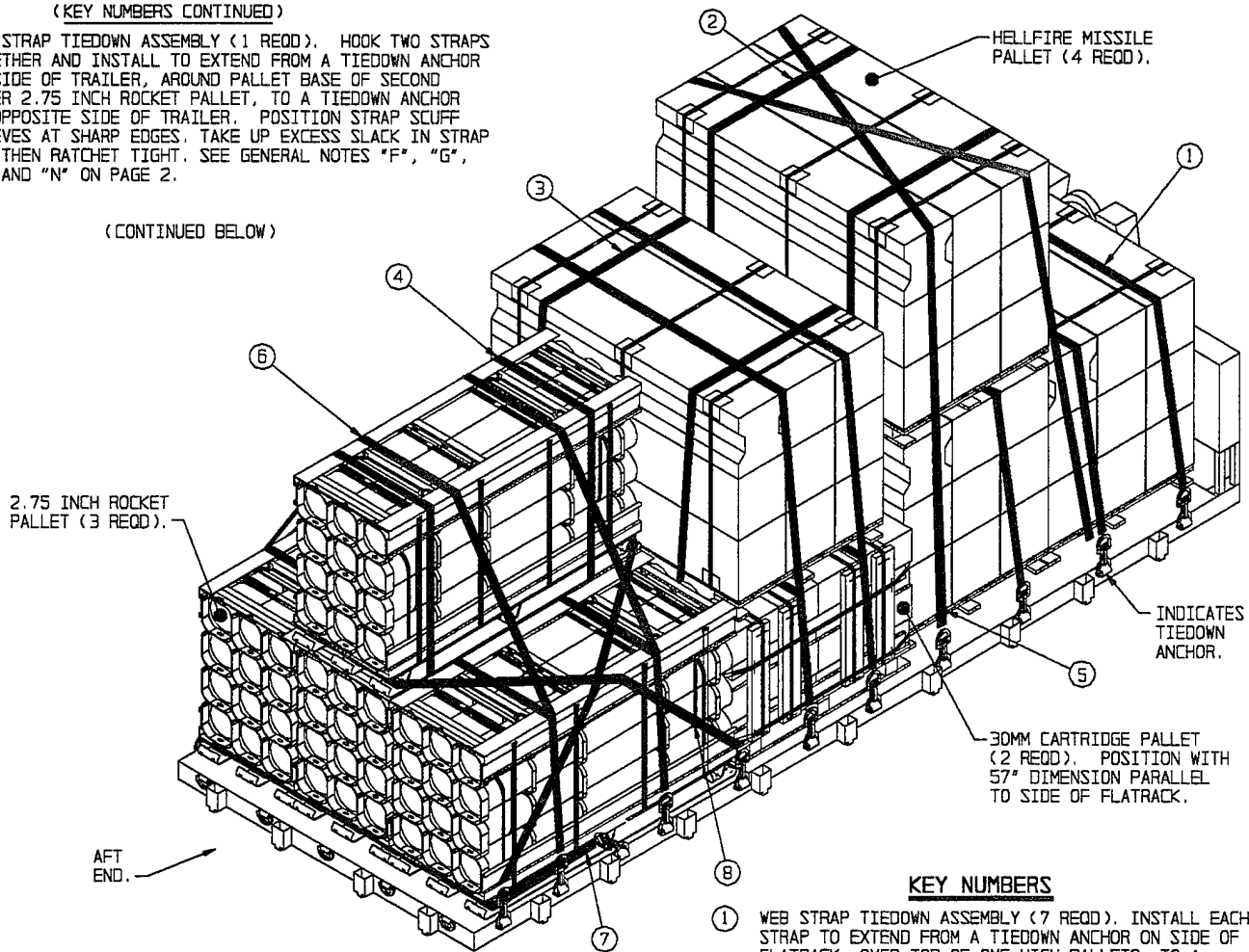

ISOMETRIC VIEW

CAUTION: LOAD HEIGHT IS 109" ABOVE CARGO DECK FLOOR. WHEN TRANSPORTING LOADS HAVING PALLET UNITS STACKED TWO HIGH REDUCE SPEED AND DRIVE CAUTIOUSLY DUE TO THE HIGHER CENTER OF GRAVITY AND POSSIBLE CLEARANCE LIMITATIONS.

(KEY NUMBERS CONTINUED)

- ⑦ WEB STRAP TIEDOWN ASSEMBLY (1 REQD). INSTALL STRAP TO EXTEND FROM A TIEDOWN ANCHOR ON SIDE OF FLATRACK, AROUND PALLET BASES AT AFT END OF LOAD, TO A TIEDOWN ANCHOR ON OPPOSITE SIDE OF FLATRACK. POSITION STRAP SCUFF SLEEVES AT SHARP EDGES. TAKE UP EXCESS SLACK IN STRAP AND THEN RATCHET TIGHT. SEE GENERAL NOTES "F" AND "G" ON ON PAGE 2.
- ⑧ WEB STRAP TIEDOWN ASSEMBLY (2 REQD). HOOK TWO STRAPS TOGETHER AND INSTALL EACH ASSEMBLY TO EXTEND FROM A TIEDOWN ANCHOR ON SIDE OF FLATRACK, OVER TOP OF BOTTOM PALLET, AROUND PALLET BASE OF TOP PALLET, OVER TOP OF BOTTOM PALLET, TO A TIEDOWN ANCHOR ON OPPOSITE SIDE OF FLATRACK. POSITION STRAP SCUFF SLEEVES AT SHARP EDGES. TAKE UP EXCESS SLACK IN STRAP AND THEN RATCHET TIGHT. SEE GENERAL NOTES "F", "G" AND "J" ON PAGE 2.

KEY NUMBERS

- ① WEB STRAP TIEDOWN ASSEMBLY (7 REQD). INSTALL EACH STRAP TO EXTEND FROM A TIEDOWN ANCHOR ON SIDE OF FLATRACK, OVER TOP OF ONE HIGH PALLET, TO A TIEDOWN ANCHOR ON OPPOSITE SIDE OF FLATRACK. POSITION STRAP SCUFF SLEEVES AT SHARP EDGES. TAKE UP EXCESS SLACK IN STRAP AND THEN RATCHET TIGHT. SEE GENERAL NOTES "F" AND "G" ON PAGE 2 AND SPECIAL NOTE 8 ON PAGE 25.
- ② WEB STRAP TIEDOWN ASSEMBLY (2 REQD). HOOK TWO STRAPS TOGETHER AND ENCIRCLE THE TWO HIGH STACK OF HELLFIRE MISSILE PALLET AT TWO PLACES. POSITION STRAP SCUFF SLEEVES AT SHARP EDGES. TAKE UP EXCESS SLACK IN STRAP AND THEN RATCHET TIGHT. NOTE: THESE TWO STRAPS MUST BE PRE-POSITIONED UNDER THE BOTTOM PALLET AS LOADING PROGRESSES. SEE GENERAL NOTES "F", "G" AND "J" ON PAGE 2.
- ③ WEB STRAP TIEDOWN ASSEMBLY (2 REQD). HOOK TWO STRAPS TOGETHER AND ENCIRCLE THE 30MM CARTRIDGE PALLET AND THE HELLFIRE MISSILE PALLET AT TWO PLACES. POSITION STRAP SCUFF SLEEVES AT SHARP EDGES. TAKE UP EXCESS SLACK IN STRAP AND THEN RATCHET TIGHT. NOTE: THESE TWO STRAPS MUST BE PRE-POSITIONED UNDER THE 30MM CARTRIDGE PALLET AS LOADING PROGRESSES. SEE GENERAL NOTES "F", "G" AND "J" ON PAGE 2.
- ④ WEB STRAP TIEDOWN ASSEMBLY (2 REQD). HOOK TWO STRAPS TOGETHER AND ENCIRCLE THE TWO HIGH STACK OF 2.75 INCH ROCKET PALLET AT TWO PLACES. POSITION STRAP SCUFF SLEEVES AT SHARP EDGES. TAKE UP EXCESS SLACK IN STRAP AND THEN RATCHET TIGHT. NOTE: THESE TWO STRAPS MUST BE PRE-POSITIONED UNDER THE BOTTOM PALLET AS LOADING PROGRESSES. SEE GENERAL NOTES "F", "G" AND "J" ON PAGE 2.
- ⑤ WEB STRAP TIEDOWN ASSEMBLY (4 REQD). HOOK TWO STRAPS TOGETHER AND INSTALL EACH STRAP TO EXTEND FROM A TIEDOWN ANCHOR ON SIDE OF FLATRACK, OVER TOP OF TWO HIGH HELLFIRE MISSILE PALLET, TO A TIEDOWN ANCHOR ON OPPOSITE SIDE OF FLATRACK. POSITION STRAP SCUFF SLEEVES AT SHARP EDGES. TAKE UP EXCESS SLACK IN STRAP AND THEN RATCHET TIGHT. SEE GENERAL NOTES "F" AND "G" ON PAGE 2.

REARM FOR FOUR APACHE HELICOPTERS

ITEM	ROUNDS REQD	ROUNDS PER PLT	PALLETS PER LOAD	ROUNDS PER LOAD	WEIGHT
30MM	4,800	2,904	2	5,808	6,416 LBS
HELLFIRE	32	9	4	36	6,996 LBS
2.75 INCH ROCKET	152	48	4	192	10,000 LBS
TOTAL			10		23,412 LBS

(CONTINUED AT LEFT)

SPECIAL NOTES:

1. A REARM LOAD FOR FOUR APACHE HELICOPTERS IS SHOWN LOADED ON THE M1077 A-FRAME FLATRACK HAVING CARGO DECK DIMENSIONS OF 228" LONG BY 90-1/2" WIDE AND A MAXIMUM LOAD WEIGHT OF 33,000 POUNDS.
2. THE LOAD SHOWN ON PAGE 24 IS TOO LONG TO BE LOADED ON THE M1 FLATRACK. SEE GENERAL NOTE "Q" ON PAGE 2.
3. IF LOADING PALLETIZED UNITS OF OTHER ITEMS, SIZES, OR QUANTITIES, FOLLOW THESE SAME PROCEDURES.
4. PRIOR TO LOADING THE PALLETIZED UNITS, ASSURE THAT ALL STEEL STRAPPING ON EACH PALLET IS IN POSITION AND IS TIGHT. MISSING AND/OR LOOSE STEEL STRAPPING SHOULD BE REPLACED.
5. POSITION THE LOAD TIGHTLY AGAINST THE A-FRAME AT THE FORWARD END OF THE FLATRACK.
6. ALL PALLETS MUST BE POSITIONED TIGHTLY AGAINST EACH OTHER Laterally AND LONGITUDINALLY. THIS WILL REDUCE LOAD MOVEMENT AND THE QUANTITY OF WEB STRAPS REQUIRED TO SECURE THE LOAD. VOID SPACES BETWEEN PALLET UNITS WILL FILL IN DURING TRANSPORT CAUSING WEB STRAPS TO BECOME LOOSE.
7. ASSURE THAT TOP PALLETS ON TWO HIGH STACKS ARE CENTERED Laterally AND LONGITUDINALLY ON TOP OF BOTTOM PALLETS PRIOR TO POSITIONING AND RATCHETING TIGHT STRAPS MARKED ②, ③, AND ④.
8. EACH LATERAL ONE HIGH AND TWO HIGH ROW OF PALLET UNITS MUST BE SECURED WITH TWO WEB STRAPS OVER THE TOP AS SHOWN. THESE TWO STRAPS MAY BE CROSSED AND/OR POSITIONED STRAIGHT ACROSS THE TOP OF A ROW. THE BOTTOM PALLET IN A TWO HIGH STACK MUST HAVE A MINIMUM OF ONE STRAP OVER THE TOP, HOWEVER, THE BOTTOM PALLET IN A TWO HIGH STACK HAVING A DIFFERENT PALLET ON TOP MUST HAVE TWO STRAPS OVER THE TOP.
9. FOR DETAILS OF THE PALLETIZED UNITS SHOWN IN THE LOAD ON PAGE 24, SEE PAGE 28 IN THIS DRAWING.
10. A TOTAL OF 36 WEB STRAP TIEDOWN ASSEMBLIES ARE REQUIRED FOR THE LOAD SHOWN.

LOAD AS SHOWN

<u>ITEM</u>	<u>QUANTITY</u>	<u>WEIGHT (APPROX)</u>
APACHE REARM	4	23,412 LBS

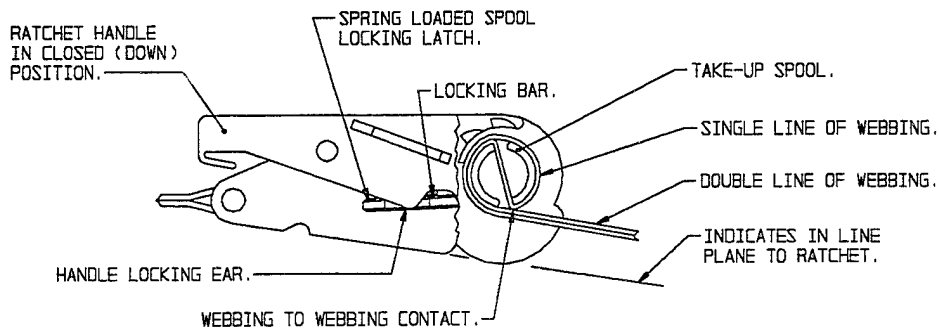

STEP 1

IN THIS VIEW PART OF THE RATCHET HOUSING IS SHOWN BROKEN AWAY TO DEPICT WEBBING-TO-WEBBING CONTACT ON THE TAKE-UP SPOOL OF THE RATCHET. WEBBING-TO-WEBBING CONTACT IS ACHIEVED WHEN THE OPERATOR HOLDS THE DOUBLE LINE OF WEBBING IN AN "IN LINE PLANE TO THE RATCHET" AND IT MAKES CONTACT WITH THE SINGLE LINE OF WEBBING.

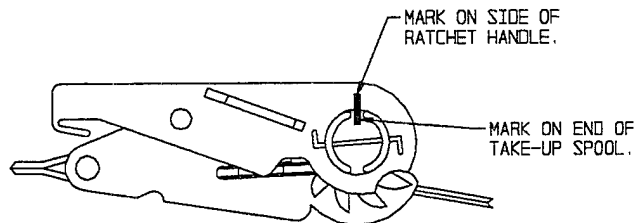

STEP 2

THIS VIEW DEPICTS THE LOCATION OF THE FIXED MARK ON THE RATCHETING HANDLE, WITH ANOTHER MATCHING MARK ON THE TAKE-UP SPOOL, AFTER WEBBING-TO-WEBBING CONTACT HAS BEEN MADE.

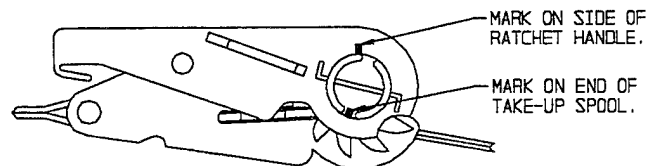

STEP 3

THIS VIEW DEPICTS THE LOCATION OF THE MARK ON THE END OF THE TAKE-UP SPOOL AFTER THE SPOOL HAS BEEN ROTATED ONE-HALF TURN, AFTER WEBBING-TO-WEBBING CONTACT HAS BEEN MADE.

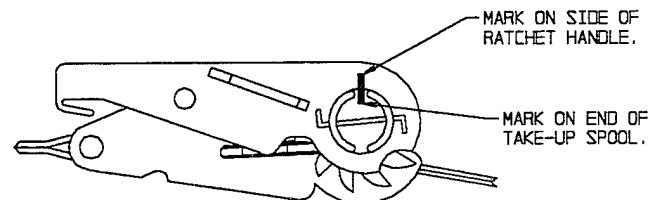

STEP 4

THIS VIEW DEPICTS THE LOCATION OF THE MARK ON THE END OF THE TAKE-UP SPOOL AFTER THE SPOOL HAS BEEN ROTATED ONE FULL TURN, AFTER WEBBING-TO-WEBBING CONTACT HAS BEEN MADE.

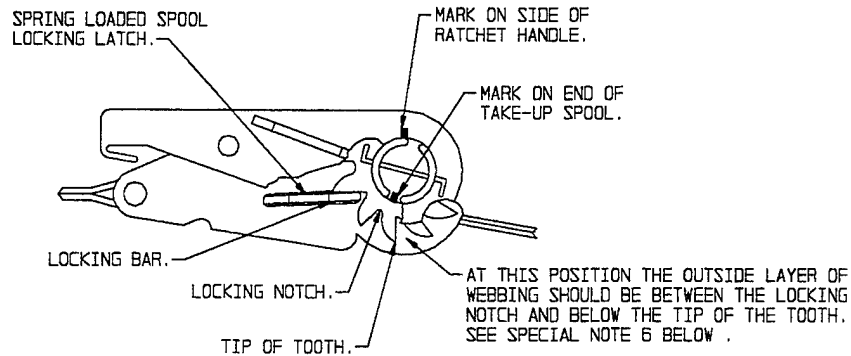

STEP 5

THIS VIEW DEPICTS THE LOCATION OF THE MARK ON THE END OF THE TAKE-UP SPOOL AFTER THE SPOOL HAS BEEN ROTATED ONE AND ONE-HALF TURNS, AFTER WEBBING-TO-WEBBING CONTACT HAS BEEN MADE. ALSO IN THIS VIEW, PART OF THE RATCHET HANDLE IS BROKEN AWAY TO SHOW THE LOCKING BAR FULLY SEATED IN THE MATCHING LOCKING NOTCH (SPROCKET GEAR TEETH).

SPECIAL NOTES:

1. THE PURPOSE OF THE RATCHET DETAILS ON PAGE 26 AND THE DETAIL AND NOTES ON THIS PAGE ARE TO AUGMENT THE GUIDANCE SET FORTH WITHIN GENERAL NOTE "F" ON PAGE 2.
2. THE REQUIREMENTS FOR 1/2 BUT NOT MORE THAN 1-1/2 WRAPS OF STRAP ON THE TAKE-UP SPOOL OF THE TENSIONING RATCHET, AS SPECIFIED WITHIN GENERAL NOTE "F" ON PAGE 2, ACTUALLY MEANS 1/2 TO 1-1/2 WRAPS OF DOUBLE WEBBING. ALSO, THE 1/2 TO 1-1/2 WRAPS (TURNS) ARE TO BE ACCOMPLISHED ONLY AFTER ENOUGH WEBBING HAS BEEN WOUND ONTO THE SPOOL TO ACHIEVE A WEBBING-TO-WEBBING CONTACT CONFIGURATION, AS SHOWN IN THE "STEP 1" DETAIL ON PAGE 26.
3. ONE METHOD THAT CAN BE USED TO ENSURE THAT THE 1/2 TO 1-1/2 WRAPS ARE WOUND ONTO THE TAKE-UP SPOOL, AFTER WEBBING-TO-WEBBING CONTACT HAS BEEN MADE, IS TO PLACE A FIXED MARK (PAINT OR SIMILAR MATERIAL) ON THE SIDE OF THE RATCHETING HANDLE, WITH THE HANDLE IN ITS CLOSED (DOWN) POSITION, AND ANOTHER SHORT MATCHING MARK ON THE END OF THE SPOOL, AS SHOWN IN THE "STEP 2" DETAIL ON PAGE 26. AS THE SPOOL IS ROTATED TO TENSION A TIEDOWN STRAP ASSEMBLY, THE NUMBER OF WRAPS (TURNS) CAN BE DETERMINED VISUALLY BY COMPARING THE "MARK" LOCATION ON THE SPOOL TO THE "MARK" LOCATION ON THE RATCHETING HANDLE WITH THE HANDLE IN CLOSED POSITION. SEE THE "STEP 3" AND "STEP 4" DETAILS ON PAGE 26, AND "STEP 5" ABOVE.
4. ANOTHER METHOD THAT CAN BE USED TO ENSURE THAT THE 1/2 TO 1-1/2 WRAPS ARE ACHIEVED, AFTER WEBBING-TO-WEBBING CONTACT HAS BEEN MADE, IS TO COUNT THE AUDIBLE CLICKS MADE BY THE RATCHET ASSEMBLY AS A WEB STRAP ASSEMBLY IS BEING TENSIONED. THE RATCHET ASSEMBLY ON MOST WEB STRAP ASSEMBLIES HAVE 11 TEETH ON THE GEARLIKE DEVICE ON EACH END OF THE TAKE-UP SPOOL; SOME OTHER STRAP ASSEMBLIES HAVE ONLY 9 TEETH. THEREFORE, AFTER INITIAL WEBBING-TO-WEBBING CONTACT HAS BEEN MADE, ROTATE (TURN) THE SPOOL THROUGH A MINIMUM OF 6 TO A MAXIMUM OF 16 CLICKS (1/2 TO 1-1/2 WRAPS) WHEN THE GEAR HAS 11 TEETH, AND ROTATE (TURN) THE SPOOL THROUGH A MINIMUM OF 5 TO A MAXIMUM OF 13 CLICKS (1/2 TO 1-1/2 WRAPS) IF THE GEAR HAS 9 TEETH.

(SPECIAL NOTES CONTINUED)

5. AFTER A STRAP ASSEMBLY HAS BEEN PROPERLY TENSIONED, CARE MUST BE EXERCISED TO ASSURE THAT THE TAKE-UP SPOOL LOCKING LATCH (SPRING LOADED DEVICE WITH A LOCKING BAR ON EACH SIDE OF THE RATCHET ASSEMBLY) IS FULLY SEATED ON BOTH SIDES IN MATCHING LOCKING NOTCHES, WHICH ARE SIMILAR TO SPROCKET GEAR TEETH, THAT ARE LOCATED ON EACH END OF THE TAKE-UP SPOOL. SEE "STEP 5" DETAIL ABOVE. THE LOCKING LATCH IS "FULLY SEATED" WHEN THE HANDLE WILL CLOSE AND THE LOCKING EAR, OR SIMILAR DEVICE ON THE HANDLE, PREVENTS THE ACCIDENTAL WITHDRAWAL OF THE LOCKING LATCH. SEE "STEP 1" DETAIL ON PAGE 26. IF THE FULLY SEATED CONDITION CANNOT BE ACHIEVED, THE STRAP MUST BE RELEASED AND HAND RETENSIONED AS TIGHT AS POSSIBLE TO ACHIEVE THE FULLY SEATED CONDITION.
6. ANOTHER VISUAL METHOD OF DETERMINING WHEN THERE IS 1/2 TO 1-1/2 WRAPS OF WEBBING ON THE TAKE-UP SPOOL, AFTER INITIAL WEBBING-TO-WEBBING CONTACT HAS BEEN MADE, IS TO LOOK AT THE SPOOL. WHEN A TIEDOWN IS COMPLETE, THE STRAP WEBBING ON THE SPOOL OF THE RATCHET SHOULD BE ABOVE THE LOWER CURVE OF THE LOCKING NOTCH, AND SHOULD BE BELOW THE TIPS OF THE TEETH OF THE RATCHET AS IDENTIFIED IN "STEP 5" ABOVE. IT SHOULD BE NOTED THAT ANY PROCEDURES THAT ENSURE PROPER TENSIONING ARE ACCEPTABLE AND THE METHODS ON THE DRAWING ONLY PROVIDE SOME OF THE APPROVED ACCEPTABLE ONES.

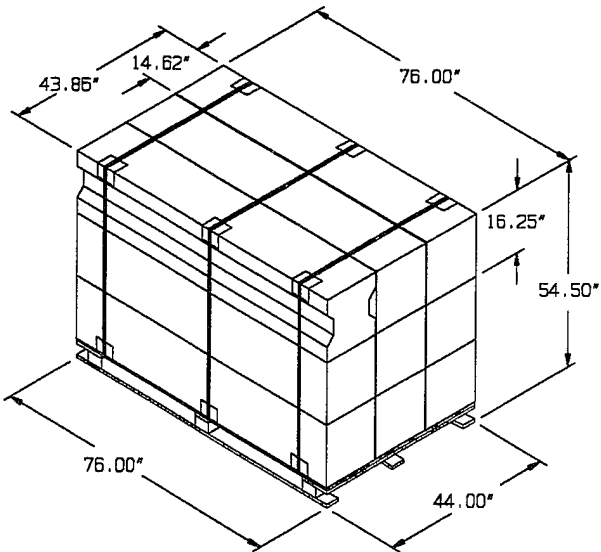

HELLFIRE MISSILE PALLET

9 CONTAINERS (9 MISSILES) - - - - 1,575 LBS (APPROX)
 PALLET AND DUNNAGE - - - - - 174 LBS

TOTAL WEIGHT - - - - - 1,749 LBS (APPROX)
 CUBE - - - - - 103.4 CUBIC FEET (APPROX)

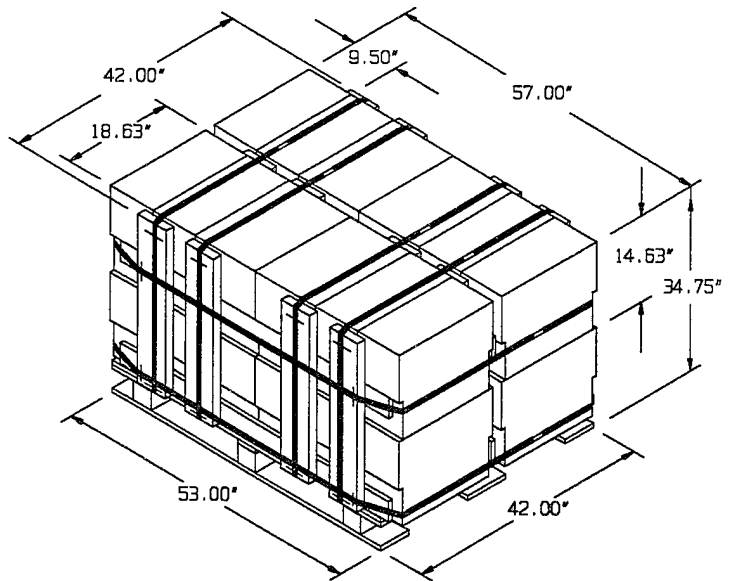

30MM CARTRIDGE PALLET

24 BOXES OF 30MM CARTRIDGES (2904 RDS) - - - 3,204 LBS (APPROX)
 PALLET AND DUNNAGE - - - - - 184 LBS

TOTAL WEIGHT - - - - - 3,208 LBS (APPROX)
 CUBE - - - - - 48.0 CUBIC FEET (APPROX)

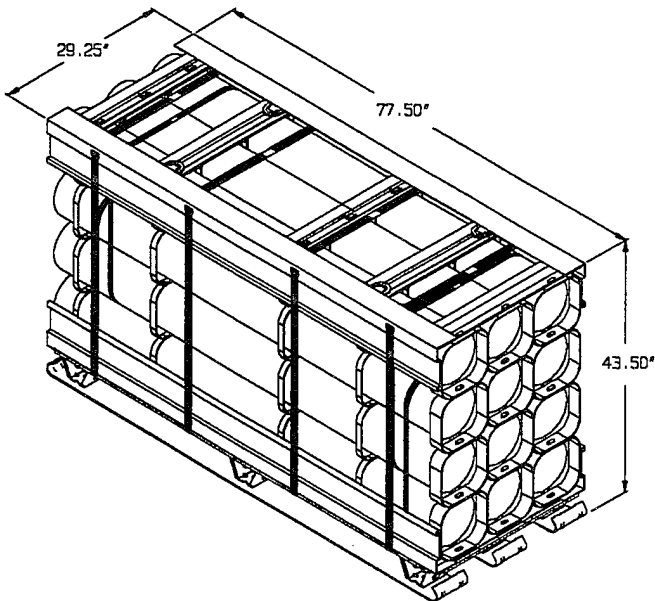

2.75 INCH ROCKET PALLET

12 CONTAINERS (48 ROCKETS) - - - - 2,500 LBS (APPROX)
 CUBE - - - - - 57.1 CUBIC FEET (APPROX)

AUTHORIZED ARMAMENT CONFIGURATIONS FOR THE AH64 APACHE HELICOPTER

NUMBER	RIGHT WING STORES		TURRET	LEFT WING STORES	
	OUTBOARD	INBOARD		INBOARD	OUTBOARD
1		4 HELLFIRE MISSILES	1,200 RDS 30MM CTG	4 HELLFIRE MISSILES	
2	EMPTY PYLON	4 HELLFIRE MISSILES	1,200 RDS 30MM CTG	4 HELLFIRE MISSILES	EMPTY PYLON
3	4 HELLFIRE MISSILES	4 HELLFIRE MISSILES	1,200 RDS 30MM CTG	4 HELLFIRE MISSILES	4 HELLFIRE MISSILES
⊕ 4	19 2.75 INCH ROCKETS	4 HELLFIRE MISSILES	1,200 RDS 30MM CTG	4 HELLFIRE MISSILE	4 HELLFIRE MISSILE
5	19 2.75 INCH ROCKETS	19 2.75 INCH ROCKETS	1,200 RDS 30MM CTG	19 2.75 INCH ROCKETS	19 2.75 INCH ROCKETS
6	EMPTY PYLON	19 2.75 INCH ROCKETS	1,200 RDS 30MM CTG	19 2.75 INCH ROCKETS	EMPTY PYLON
7		19 2.75 INCH ROCKETS	1,200 RDS 30MM CTG	19 2.75 INCH ROCKETS	
8	19 2.75 INCH ROCKETS	EMPTY PYLON PLUS EXT FUEL TANK	1,200 RDS 30MM CTG	EMPTY PYLON PLUS EXT FUEL TANK	19 2.75 INCH ROCKETS
9	EMPTY PYLON PLUS EXT FUEL TANK	EMPTY PYLON PLUS EXT FUEL TANK	1,200 RDS 30MM CTG	EMPTY PYLON PLUS EXT FUEL TANK	EMPTY PYLON PLUS EXT FUEL TANK
10	EMPTY PYLON	EMPTY PYLON PLUS EXT FUEL TANK	1,200 RDS 30MM CTG	EMPTY PYLON PLUS EXT FUEL TANK	EMPTY PYLON
11		EMPTY PYLON PLUS EXT FUEL TANK	1,200 RDS 30MM CTG	EMPTY PYLON PLUS EXT FUEL TANK	
12	EMPTY PYLON	EMPTY PYLON	1,200 RDS 30MM CTG	EMPTY PYLON	EMPTY PYLON

NOTE ⊕: ARMAMENT CONFIGURATION NUMBER 4 IS DEPICTED WITHIN THIS DRAWING AS ONE APACHE REARM, IF LOADING OTHER ARMAMENT CONFIGURATIONS FOLLOW THESE SAME PROCEDURES.

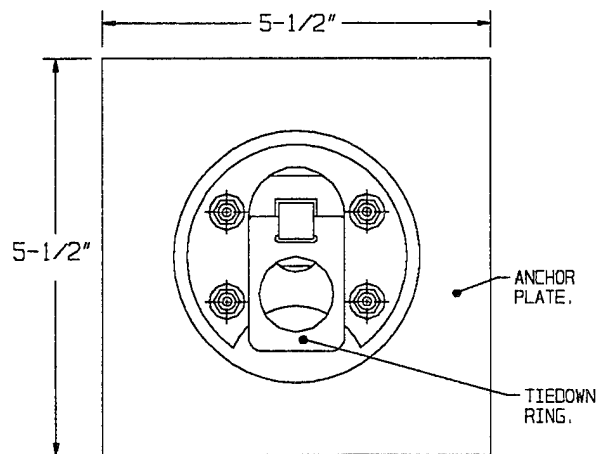

UNIVERSAL TIEDOWN ANCHOR (FRONT VIEW)

UNIVERSAL TIEDOWN ANCHOR: IF THE TACTICAL VEHICLES BEING USED ARE NOT EQUIPPED WITH TIEDOWN ANCHORS, THE UNIVERSAL TIEDOWN ANCHOR SHOWN ABOVE MAY BE INSTALLED. SEE TB 9-2300-280-30 FOR VEHICLE MODIFICATION PROCEDURES AND INSTALLATION OF THE TIEDOWN ANCHOR. THESE TIEDOWN ANCHORS ARE TO BE INSTALLED IN THE SIDE WALLS AND END WALLS OF CARGO TRUCKS AND CARGO TRAILERS HAVING A LOAD CAPACITY OF 5 TONS OR LESS.