

te technical note tech1

ARSR-4 OT&E Test Plan for the EARTS and MicroEARTS

Raymond K. McDonald

DISTRIBUTION STATEMENT A
Approved for public release;
Distribution Unlimited

June 1996

DOT/FAA/CT-TN96/17

Document is on file at the William J. Hughes Technical Center
Library, Atlantic City International Airport, NJ 08405

19960801 080



U.S. Department of Transportation
Federal Aviation Administration

William J. Hughes Technical Center
Atlantic City International Airport, NJ 08405

DTIC QUALITY INSPECTED 1

NOTICE

This document is disseminated under the sponsorship of the U.S. Department of Transportation in the interest of information exchange. The United States Government assumes no liability for the contents or use thereof.

The United States Government does not endorse products or manufacturers. Trade or manufacturers' names appear herein solely because they are considered essential to the objective of this report.

1. Report No. DOT/FAA/CT-TN96/17	2. Government Accession No.	3. Recipient's Catalog No.	
4. Title and Subtitle ARSR-4 OT&E TEST PLAN FOR THE EARTS AND MICROEARTS		5. Report Date June 1996	
		6. Performing Organization Code	
7. Author(s) Raymond K. McDonald		8. Performing Organization Report No. DOT/FAA/CT-TN96/17	
9. Performing Organization Name and Address U.S. Department of Transportation Federal Aviation Administration Technical Center Atlantic City International Airport, NJ 08405		10. Work Unit No. (TRAIS)	
		11. Contract or Grant No.	
12. Sponsoring Agency Name and Address U.S. Department of Transportation Federal Aviation Administration Technical Center Atlantic City International Airport, NJ 08405		13. Type of Report and Period Covered Technical Note	
		14. Sponsoring Agency Code	
15. Supplementary Notes			
<p>16. Abstract</p> <p>The Air Route Surveillance Radar Model 4 (ARSR-4) is a state-of-the-art, three-dimensional, long-range unattended radar. The system is being jointly procured by the Federal Aviation Administration (FAA) and the U.S. Military. This radar will replace aging height-finding and long-range two-dimensional air search radars which are currently in use. Forty-four ARSR-4 systems are scheduled for installation around the coastal United States and in Hawaii, Guam, and Guantanamo Bay, Cuba.</p> <p>This document defines the overall planning, test activities, and coordination associated with the Operational Test and Evaluation (OT&E) of the ARSR-4/En Route Automated Radar Tracking System (EARTS) and ARSR-4/Microprocessor En Route Automated Radar Tracking System (MicroEARTS) interfaces. The tests will be performed at the FAA Technical Center, the Mt. Santa Rosa and Mt. Kaala ARSR-4 facilities, and the Guam and Honolulu Center Enroute Radar Approaches (CERAPs).</p> <p>The tests are divided into two major categories: Integration tests and Operational tests. Integration tests include data format verification, capacity and delay tests, and a system performance evaluation. During Operational tests, Air Traffic Control (ATC) personnel will evaluate the effectiveness and suitability of the ARSR-4 when operated with an EARTS or MicroEARTS. Operational questionnaires will address critical performance areas including search, beacon, and weather processing.</p>			
17. Key Words ARSR-4 EARTS MicroEARTS Operational Integration		18. Distribution Statement Document is on file at the Technical Center Library, Atlantic City International Airport, NJ 08405	
19. Security Classif. (of this report) Unclassified	20. Security Classif. (of this page) Unclassified	21. No. of Pages 41	22. Price

TABLE OF CONTENTS

	Page
EXECUTIVE SUMMARY	v
1. INTRODUCTION	1
1.1 PURPOSE	1
1.2 SCOPE	1
1.3 BACKGROUND	1
2. REFERENCE DOCUMENTS	2
3. SYSTEM DESCRIPTION	2
4. TEST MANAGEMENT	3
4.1 ROLES AND RESPONSIBILITIES	3
4.2 TEST SCHEDULE	4
4.3 QUALITY CONTROL AND CONFIGURATION MANAGEMENT	4
4.4 TEST READINESS CRITERIA	5
4.5 TEST EXECUTION	5
4.6 TEST COMPLETION CRITERIA	5
5. DOCUMENTATION	6
5.1 ARSR-4/EARTS AND ARSR-4/MICROEARTS OT&E TEST PROCEDURES	6
5.2 TEST DISCREPANCY REPORTS	6
5.3 ATC QUESTIONNAIRES	6
5.4 FINAL TEST REPORT	6
6. OT&E INTEGRATION TESTS	7
6.1 DATA FORMAT VERIFICATION	9
6.2 CAPACITY AND DELAY	10
6.3 PERFORMANCE EVALUATION	12
7. OT&E OPERATIONAL TESTS	13
7.1 CONTROLLER EVALUATIONS	13
8. ACRONYMS AND ABBREVIATIONS	15
APPENDIXES	
A - OT&E TEST SCHEDULE	
B - TEST VERIFICATION REQUIREMENTS TRACEABILITY MATRIX (TVRTM)	
C - ATC OPERATIONAL TEST QUESTIONNAIRE	

LIST OF ILLUSTRATIONS

Figure		Page
1	FAA Technical Center Test Configuration	7
2	Guam Test Configuration	7
3	Hawaii Test Configuration	8

LIST OF TABLES

Table		Page
1	Test Locations	8

EXECUTIVE SUMMARY

This document defines the overall planning, test activities, and coordination associated with the Operational Test and Evaluation (OT&E) of the Air Route Surveillance Radar Model 4 (ARSR-4)/Enroute Automated Radar Tracking System (EARTS) and ARSR-4/Microprocessor Enroute Automated Radar Tracking System (MicroEARTS) interfaces. The tests will be performed at the Federal Aviation Administration (FAA) Technical Center, the Mt. Santa Rosa and Mt. Kaala ARSR-4 facilities, and the Guam and Honolulu Center Enroute Radar Approach (CERAP) facilities.

The tests are divided into two major categories: Integration tests and Operational tests. Integration tests include data format verification, capacity and delay tests, and a system performance evaluation. Data format verification will consist of an examination of all ARSR-4 message types transmitted to the EARTS and MicroEARTS. Capacity and delay tests will determine the ability of the ARSR-4/EARTS and ARSR-4/MicroEARTS interface to process and output targets when under capacity conditions. The performance evaluation will verify that the ARSR-4, when interfaced to an EARTS or MicroEARTS, provides adequate primary and secondary coverage with a low false alarm rate.

During Operational tests, Air Traffic Control (ATC) personnel will evaluate the effectiveness and suitability of the ARSR-4 when operated with an EARTS or MicroEARTS. Operational questionnaires will address critical performance areas including search, beacon, and weather processing.

1. INTRODUCTION.

1.1 PURPOSE.

The purpose of this document is to define the overall planning, test activities, and coordination associated with the Operational Test and Evaluation (OT&E) of the Air Route Surveillance Radar Model 4 (ARSR-4)/Enroute Automated Radar Tracking System (EARTS) and ARSR-4/Microprocessor Enroute Automated Radar Tracking System (MicroEARTS) interfaces. The tests will be performed at the Federal Aviation Administration (FAA) Technical Center, the Mt. Santa Rosa and Mt. Kaala ARSR-4 facilities, and the Guam and Honolulu Center Enroute Radar Approach (CERAP) facilities. These tests will be performed in accordance with the policies stated in FAA Order 1810.4b, FAA NAS Test and Evaluation Policy.

1.2 SCOPE.

This OT&E plan:

- a. Identifies the test objectives to be verified at the FAA Technical Center, Mt. Santa Rosa and Mt. Kaala ARSR-4 facilities, the Honolulu and Guam CERAPs, and the test configurations employed for verification.
- b. Defines resources required by OT&E, including the ARSR-4, EARTS, MicroEARTS, test hardware, and software. Also, those activities which require support from other organizations are identified.
- c. Establishes a basis for the development of detailed test procedures used to perform the ARSR-4/EARTS and ARSR-4/MicroEARTS OT&E Operational and OT&E Integration tests.

1.3 BACKGROUND.

The ARSR-4 is a state-of-the-art, three-dimensional, long-range unattended radar. The system is being jointly procured by the FAA and the U.S. Military. This radar will replace aging height-finding and long-range two-dimensional air search radars which are currently in use. Forty-four ARSR-4 systems are scheduled for installation around the coastal United States and in Hawaii, Guam, and Guantanamo Bay, Cuba.

OT&E tests were performed on the first fielded ARSR-4 at Mt. Laguna, CA. OT&E was completed August 14, 1995. The Deployment Readiness Review (DRR) was conducted November 2, 1995. At that time the decision was made to proceed with full deployment of all systems. ARSR-4 equipment is currently being deployed with the last system delivery scheduled for December 1996.

The majority of ARSR-4 systems will interface to the HOST and Direct Access Radar Channel (DARC) enroute computers at each Air Route Traffic Control Center (ARTCC). These interfaces were thoroughly tested at the Mt. Laguna site and Los Angeles ARTCC. The ARSR-4 is also required to interface to the EARTS and MicroEARTS enroute computers. These interfaces have not been tested because of the unavailability of that equipment at the Los Angeles ARTCC.

The Mt. Santa Rosa site in Guam will be the first ARSR-4 to interface to a MicroEARTS computer and display system located at the Guam CERAP. The Mt. Kaala, Hawaii ARSR-4 site will interface with the EARTS enroute computer located at the Honolulu CERAP.

2. REFERENCE DOCUMENTS.

- | | |
|-------------------|---|
| FAA-E-2763b | ARSR-4 Radar System Specification.
Dated: May 6, 1988. |
| FAA ORDER 1810.4b | FAA NAS Test and Evaluation Policy.
Dated: October 22, 1992 |
| FAA ORDER 1812.8 | System Requirements Statement for the ARSR-4.
Dated: August 29, 1986. |
| NAS-SS-1000 | Functional and Performance Requirements for the NAS
System Specification, Vols. I, II, V.
Dated: December 1986. |
| | Interface Control Document for the ARSR-4 to EARTS and
MicroEARTS. Dated: Draft Copy. |
| | ARSR-4 Technical Instruction Books.
Dated: January 16, 1994. |

3. SYSTEM DESCRIPTION.

The primary mission of the ARSR-4 is to provide high quality, digital primary radar data on aircraft positions to the ARTCC and to the Sector Operations Control Center (SOCC). When interfaced with an air traffic control beacon interrogator (ATCBI) or Mode Select beacon system (Mode S), the ARSR-4 will also provide secondary radar (beacon) data on transponder equipped aircraft. The secondary mission of the ARSR-4 is to report three levels of weather within the coverage area.

Detailed operational characteristics for the ARSR-4 are defined in the FAA operational requirements document (ORD). The key operational characteristics are:

a. Coverage. The coverage volume of the ARSR-4 extends from 5 to 250 nautical miles (nm) for 360° and from the radar line of site (RLS) to 100,000 feet above ground level (AGL) or 30° elevation. A look down beam detects targets above -7°. The ARSR-4 must detect a 2.2 square meter radar cross section (RCS) target within this volume at any range less than 200 nm with a probability of 80 percent or greater.

b. False Reports. The ARSR-4 is required to operate in all clutter environments with minimal degradation in detection and no more than 194 false primary target reports per scan.

c. Positional Accuracy. The ARSR-4 required primary radar positional accuracy is 1/16 nm root-mean-squared (rms) in range, two azimuth change pulses (ACPs) rms in azimuth and 3000 feet rms in height (within 175 nm). The required beacon positional accuracy is 1/32 nm rms in range for stationary targets, 1/16 nm rms in range for moving targets, 2 ACPs rms in azimuth, and within 125 feet in height with 95 percent probability.

d. Resolution. The ARSR-4 must resolve two closely spaced aircraft at least 90 percent of the time when separated by 1/8 nm in range and 2.0° in azimuth.

e. Weather Detection. The ARSR-4 will provide three-level weather detection within the coverage volume with minimal degradation from ground clutter and second time around weather.

f. Remote Monitoring. The ARSR-4 will provide remote monitoring, control, and diagnostic capability through RMMS.

g. Operational Availability. The ARSR-4 operational availability will be at least 0.99742. The ARSR-4 will be operable and maintainable with the currently available work force and skill levels and require minimal periodic maintenance visits.

h. Site Adaptation and Optimization. The ARSR-4 will be site adaptable using a well defined and efficient procedure. ARSR-4 will require minimal readjustment or parameter optimization to compensate for environmental and seasonal changes.

4. TEST MANAGEMENT.

This section describes the roles and responsibilities of the organizations participating in the ARSR-4/EARTS and ARSR-4/MicroEARTS OT&E Integration and OT&E Operational tests. The criteria which must be met before tests can begin will also be discussed. In addition, FAA Order 1810.4b shall be used as guidance where applicable.

4.1 ROLES AND RESPONSIBILITIES.

The principal organizations participating in the OT&E tests are shown below. Each organization is listed along with their specific roles and responsibilities.

<u>Organization</u>	<u>Primary Roles/Functions</u>
AND-440	Has overall responsibility for ARSR-4 acquisition. The Program Manager (PM) will direct, manage, and fund all FAA activities for the test program. The PM shall be the FAA spokesperson for the ARSR-4 program. Will approve the OT&E Test Plan.
ACT-310	Responsible for the OT&E effort. Will participate in Technical Reviews and meetings. Will coordinate and conduct OT&E Operational and OT&E Integration tests. Will establish a test schedule. Will provide a report assessing the operational effectiveness and suitability of the system.

AOS-230	Provides technical support during OT&E.
AOS-400	Will review ARSR-4/EARTS, MicroEARTS documentation and provide input to its correctness. Shall provide EARTS and MicroEARTS operational software and support.
ATR-110	Will coordinate participation of Air Traffic Control (ATC) personnel during OT&E from a national level.
ATR-454	Will coordinate participation of ATC personnel during OT&E at a regional level.
AWP-400	Will provide the facilities required during the testing period. Shall supply the necessary personnel for proper maintenance and upkeep of the tested ARSR-4 systems.
ASU-421	Shall perform configuration audit for each system ensuring all hardware modifications were performed. Will monitor acceptance testing.

Personnel from the following facilities will provide equipment maintenance support during OT&E:

- a. Guam CERAP,
- b. Honolulu CERAP,
- c. Mt. Santa Rosa, Guam, ARSR-4 site,
- d. Mount Kaala, Hawaii, ARSR-4 site.

4.2 TEST SCHEDULE.

OT&E will begin following the successful completion of site acceptance tests and radar optimization by Air Force Radar Evaluation Squadron and FAA regional personnel. Final acceptance of the Guam site is scheduled for June 3, 1996. Site optimization will start after acceptance and last for about 2 weeks. OT&E will follow optimization and continue for 3 weeks.

Final acceptance of the Mt. Kaala ARSR-4 is scheduled for January 14, 1997. Site optimization and OT&E will follow acceptance and will have the same duration as the Guam site. An integrated schedule for the ARSR-4/EARTS and ARSR-4/MicroEARTS OT&E is shown in appendix A.

4.3 QUALITY CONTROL AND CONFIGURATION MANAGEMENT.

ARSR-4, EARTS, and MicroEARTS configurations will not be modified during OT&E. A configuration audit will be performed by ASU-421, which will document the system configuration. This baseline configuration will be maintained throughout the test period. Any system modifications shall be documented in the site log book and reported to the test lead. Retest will be required when there is a test failure, modification to the ARSR-4 or EARTS/MicroEARTS, or modification to ATC procedures which could invalidate test results.

4.4 TEST READINESS CRITERIA.

The following prerequisites shall be met before OT&E can begin:

- a. The ARSR-4 shall be accepted by the government,
- b. ARSR-4 communication lines and latest hardware must be installed,
- c. The latest ARSR-4 software build must be installed and benchmark tested in the factory,
- d. The ARSR-4 must be optimized by government engineers according to established procedures,
- e. The ARSR-4 system baseline must be stable (i.e., no major modifications likely),
- f. Any needed EARTS or MicroEARTS software/hardware modifications must be completed and in place,
- g. Approval of the OT&E Test Plan,
- h. Approval of the Air Traffic Evaluation questionnaire.

4.5 TEST EXECUTION.

The test team will verify that the ARSR-4 is in an optimized and stable state. All ARSR-4 Site Adaptable Parameters (SAPs) and Field Adaptable Parameters (FAPs) will be recorded. Any significant modifications required in the ARSR-4, EARTS, or MicroEARTS to make the system usable would mandate a retest to validate corrections. Details of specific tests are contained in the OT&E Test Procedures. The tests will focus on verifying the requirements listed in the TVRTM (see appendix B).

4.6 TEST COMPLETION CRITERIA.

The test effort will be declared complete when data is collected to verify the ARSR-4 reliably transmits all expected message types and the EARTS and MicroEARTS correctly process all ARSR-4 messages. Sufficient data must be collected to determine the ARSR-4/EARTS and ARSR-4/MicroEARTS interfaces process a capacity target load in a timely manner, and provide suitable radar data within the required coverage area. Ample time (2 weeks) shall be allowed for air traffic controllers to determine the suitability and effectiveness of the ARSR-4 when operating with the EARTS and MicroEARTS.

5. DOCUMENTATION.

This section identifies the test documentation and reports that will be generated from these OT&E efforts. A description of each generated document is also included.

5.1 ARSR-4/EARTS AND ARSR-4/MICROEARTS OT&E TEST PROCEDURES.

Test procedures will provide the detailed instructions for each test specified in the test plan. This document will indicate the particulars for each test. The procedures will contain the following:

- a. The test objectives,
- b. The verification requirements and criteria of success for each objective,
- c. A description of each test and the test location,
- d. The test resources required including: support hardware, support software, and personnel needed to conduct the tests,
- e. The detailed test instructions which will include the required steps or actions along with the test configurations required to perform the OT&E.

5.2 TEST DISCREPANCY REPORTS.

Test Discrepancy Reports (TDR) will be generated if system anomalies or deficiencies are found. These TDRs will identify the OT&E test being performed when the discrepancy was discovered. The report will also contain a detailed description of the particular problem and how it was discovered along with a recommendation for resolution. These reports will be forwarded to the Program Office, AND-440.

5.3 ATC QUESTIONNAIRES.

Questionnaires will be given to air traffic controllers before operational tests begin. The questionnaires will be a source of input from the controllers concerning the suitability and effectiveness of the ARSR-4 operating in the National Airspace System (NAS). The controllers will also record events and observations occurring during the tests. The questionnaire is attached in appendix C.

5.4 FINAL TEST REPORT.

A Final Test Report will summarize the results of each OT&E effort. A draft report will be delivered 30 days after the completion of tests at each site. The reports will contain the specific test objectives, descriptions, requirements, and success criteria used for evaluation. It will contain data collection and analysis methods used, along with results and conclusions for each test. Any system discrepancies found during tests will also be discussed.

6. OT&E INTEGRATION TESTS.

The ARSR-4/EARTS and ARSR-4/MicroEARTS integration tests will be performed at: the FAA Technical Center, the ARSR-4 facility in Mt. Santa Rosa, the ARSR-4 facility in Mt. Kaala, the Guam CERAP, and Honolulu CERAP. The tests at the Technical Center will allow for initial verification of the interface. The tests in Guam and Hawaii will provide for complete verification of the ARSR-4/MicroEARTS and ARSR-4/EARTS interfaces. The test configurations for the test locations are shown in figures 1 through 3. Figure 1 shows the playback configuration that will be used at the Technical Center. Figure 2 shows the MicroEARTS configuration at the Guam site. Figure 3 shows the EARTS configuration at the Hawaii site.

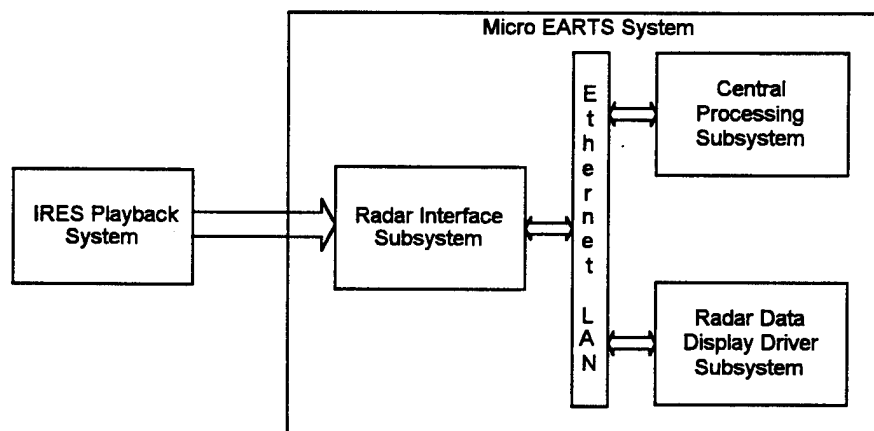

FIGURE 1. FAA TECHNICAL CENTER TEST CONFIGURATION

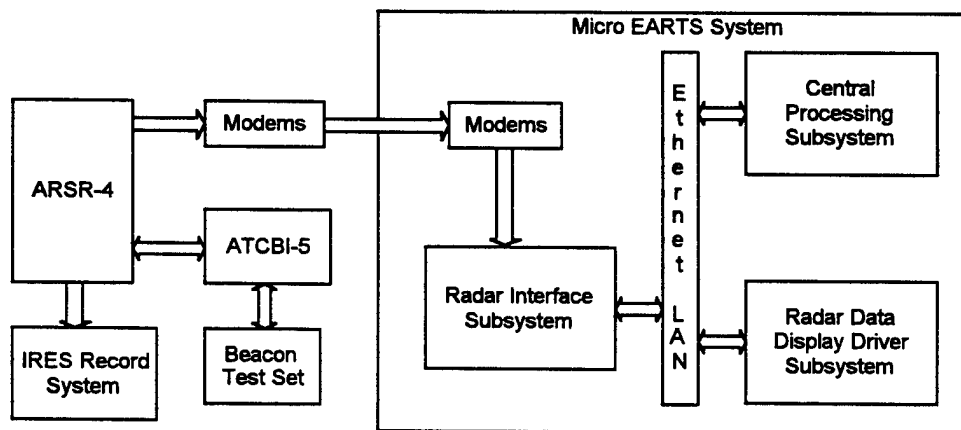

FIGURE 2. GUAM TEST CONFIGURATION

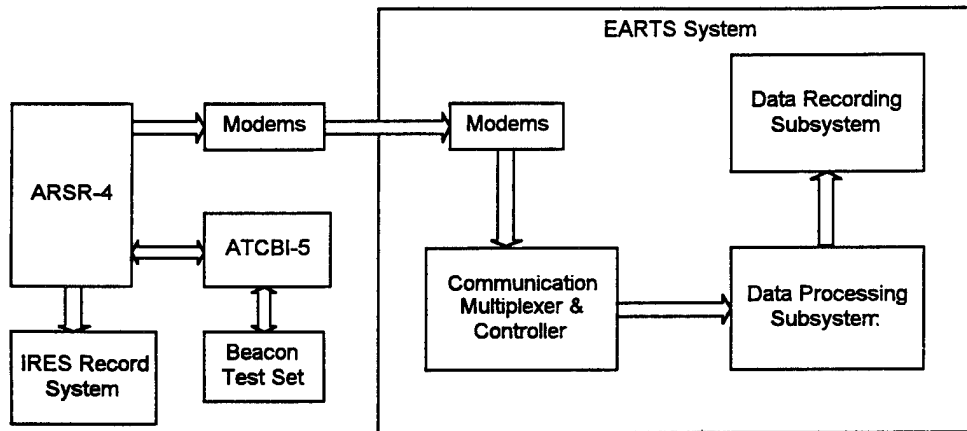

FIGURE 3. HAWAII TEST CONFIGURATION

The following tests will be performed to verify the operational aspects of the ARSR-4/EARTS and ARSR-4/MicroEARTS interface:

- a. Data Format Verification
- b. Capacity and Delay
- c. System Performance Evaluation
- d. Air Traffic Controller Evaluations

Table 1 shown below provides an indication where each of the above tests will be performed.

TABLE 1. TEST LOCATIONS

	Technical Center	Mt. Santa Rosa	Mt. Kaala
Data Formats	X	X	X
Capacity & Delay		X	X
Sys. Performance		X	X
Controller Eval.		X	X

6.1 DATA FORMAT VERIFICATION.

6.1.1 Purpose.

Ensure that the ARSR-4/EARTS and ARSR-4 MicroEARTS interfaces reliably transmit and process all expected message types.

6.1.2 Test Objectives.

The objectives for this test are as follows:

- a. Verify that the ARSR-4 outputs CD-2 messages in the correct format to the EARTS and MicroEARTS.
- b. Verify that the EARTS and MicroEARTS correctly process ARSR-4 messages.
- c. Verify that the ARSR-4 consistently reports beacon and search Real-Time Quality Control (RTQCs) and status messages to the user on each scan.
- d. Verify that the ARSR-4 can detect, process, and report civil and military beacon emergencies in the proper format.
- e. Verify that changes in the ARSR-4 status are detected and accurately reported in the status messages sent to the EARTS and MicroEARTS.
- f. Verify that the status reported in the CD-2 status message is consistent with beacon environmental RMS status.
- g. Verify that the ARSR-4 correctly outputs three-level weather data to the EARTS and MicroEARTS.

6.1.3 Test Description.

Initial interface verification will be performed with the Technical Center MicroEARTS. Previously recorded surveillance and weather data will be injected into the MicroEARTS using the Integrated Radar Evaluation System (IRES) Playback System. Data will be recorded at the output of the MicroEARTS. The input and output data files will be compared to verify that all message types are correctly processed. The remaining OT&E will be performed at the Mt. Santa Rosa and Mt. Kaala ARSR-4 sites, and the Guam and Honolulu CERAPs.

Target of Opportunity data will be recorded with an IRES record interface board to verify that the ARSR-4 outputs each message type in the correct format. Analysis of this data will also verify that beacon RTQC's, search RTQC's, and status messages were output to the user on each scan.

Beacon replies will be injected with a Sensis Video Beacon Interrogator Test Set into the ARSR-4 to verify that the EARTS and MicroEARTS can process ARSR-4 beacon reports. This will also verify that the ARSR-4 properly processes replies and outputs beacon emergency reports. The data will be recorded and analyzed using IRES.

To exercise the CD status message bits, configuration changes will be made to the ARSR-4 and/or the beacon system. Data will be recorded at the ARSR-4 with IRES and recorded at the EARTS or MicroEARTS processor output using its Continuous Data Recording (CDR) capability. RMS menu screens will be monitored for the appearance of alarms with injected faults. The recorded data will be analyzed to verify that the EARTS and MicroEARTS report the correct status and that the proper bit was set in the message.

Weather test targets will be injected into the ARSR-4 using the weather test target generator. This will verify that the ARSR-4 outputs the required three weather levels in the correct format and the EARTS and MicroEARTS correctly process and display the weather. Data will be recorded at the ARSR-4 with IRES and recorded at the EARTS or MicroEARTS using its CDR capability. Data will be analyzed using IRES.

6.1.4 Test Support Requirements.

The following subsections list or describe the support hardware, software, and system requirements necessary to perform the tests.

6.1.4.1 Support Hardware.

- a. ARSR-4 system interfaced to the EARTS and MicroEARTS
- b. ATCBI-5 or equivalent beacon interrogator
- c. PC-AT compatible computers
- d. IRES Record Interface Board
- e. VideoBITS, Beacon Reply Video Generator
- f. UPM-155 Beacon Test Set
- g. IRES Playback Interface Board
- h. ARSR-4 Test Target Generators

6.1.4.2 Support Software.

- a. IRES Analysis Software
- b. Current baselined and tested ARSR-4 software build
- c. NAS software build for EARTS and MicroEARTS with ARSR-4 adaptation

6.2 CAPACITY AND DELAY.

6.2.1 Purpose.

Determine the ability of the ARSR-4/EARTS and ARSR-4/MicroEARTS interfaces to process and output a capacity target load in a timely manner.

6.2.2 Test Objectives.

The objectives for this test are as follows:

- a. Verify the EARTS and MicroEARTS can process an operationally expected capacity load.
- b. Verify that, when the ARSR-4 is not operating with the Mode S system, the overall data delay during peak loads from the antenna peak of beam to report being placed in the output que is no greater than 1.5 seconds.

c. Verify that the ARSR-4 can process and provide message outputs for a steady state maximum load of 800 aircraft returns within the primary radar coverage area.

d. Verify that the ARSR-4 can process and provide message outputs for a large sector peak consisting of 50 aircraft returns in each of eight contiguous 11.25° sectors.

e. Verify that the ARSR-4 can process and provide message outputs for a small sector peak consisting of 20 aircraft returns in each of three contiguous 1.2° sectors.

f. Verify that the ARSR-4 can process and provide message outputs for a azimuth peak of 60 aircraft returns aligned in an azimuth radial.

g. Verify that the ARSR-4 can process and provide message outputs for a range distribution peak of four aircraft returns within a 4.5 nm interval not equally spaced.

6.2.3 Test Description.

Capacity and delay tests will be conducted by injecting capacity scenarios of search, beacon, and FRUIT targets into the ARSR-4. The ARSR-4 test target generator will be used to inject search targets. A separate beacon test target generator will be used to inject the beacon scenarios. The ATCBI-5 and ARSR-4 transmitters will be disabled to eliminate live targets.

The output data will be time tagged and recorded using IRES. The recorded data will be analyzed to determine the delay distribution for all target reports. The number of reports recorded will be compared to the number of reports injected to determine if the ARSR-4 meets capacity requirements. EARTS/MicroEARTS output data will be recorded with CDR. This data will be analyzed to verify that the EARTS or MicroEARTS processed and output all injected targets.

6.2.4 Test Support Requirements.

The following subsections list or describe the support hardware, software, and system requirements necessary to perform the tests.

6.2.4.1 Support Hardware.

- a. ATCBI-5 or equivalent beacon interrogator
- b. PC-AT compatible computers
- c. IRES Record Interface Board
- d. SENSIS Beacon Extractor (BEXR) System
- e. VideoBITS, Beacon Reply Video Generator
- f. ARSR-4 Test Target Generator
- g. Hewlett Packard Logic Analysis System
- h. UPM-155 Beacon Test Set

6.2.4.2 Support Software.

- a. IRES Analysis Software
- b. Current ARSR-4 software build

6.2.4.3 System Requirements.

Any existing collocated primary radar system operating at the same frequency may be required to stop transmitting (i.e., search down time) for a short period of time, to properly perform capacity and delay tests.

6.3 PERFORMANCE EVALUATION.

6.3.1 Purpose.

Verify that the ARSR-4 provides air traffic controllers with suitable primary and secondary radar data within the required coverage area.

6.3.2 Test Objectives.

The objectives for this test are as follows:

a. Verify that the ARSR-4 is capable of detecting and reporting aircraft targets to a range of 250 nm and from the earth's surface as low as -7° to a maximum of 30° in elevation and to a maximum height of 100,000 feet Mean Sea Level (MSL).

b. Verify that, when averaged over 10 scans, the number of false reports per scan at the output first function of the scan to scan correlation function shall not exceed a total of 194.

c. Verify that the ARSR-4 Beacon Target Processor (BTP) outputs no more than four false target reports per scan.

d. Verify that the ARSR-4 BTP does not generate more than one beacon target report 99.5 percent of the time from a single aircraft's beacon reply sequence which is in response to interrogations from the associated beacon radar.

e. Verify that the ARSR-4 BTP validates the beacon code information as contained in the aircraft's reply for Modes 2, 3/A, and C at least 95 percent of the time when the number of actual hits received per mode is 11 or greater.

f. Verify that the ARSR-4 provides a radar/beacon reinforcement rate of at least 80 percent.

6.3.3 Test Description.

Target of opportunity data will be collected at the output ports of the ARSR-4 with the IRES Record Interface. Data will also be collected at the EARTS and MicroEARTS processor output with its CDR capability. The output data will be analyzed using IRES Analysis software and EARTS Quick Analysis of Radar Systems (EQARS) software. Data will be analyzed to verify that the ARSR-4 provides adequate coverage at all required ranges and elevations. The ARSR-4 and EARTS/MicroEARTS output data will be compared and any differences will be noted.

Data will be analyzed to ensure that the number of false alarms generated by the ARSR-4 are acceptably few, and are manageable in the ATC system. The false alarm investigation will include: radar false alarms, beacon range splits, beacon azimuth splits, and ring around. Beacon

validation rates for Modes 2, 3/A, and C will be checked to ensure that they are operationally acceptable for air traffic use. The radar/beacon reinforcement rate for target of opportunity aircraft will be measured to ensure that the ARSR-4 provides acceptable merge rates for ATC.

6.3.4 Test Support Requirements.

The following subsections list or describe the support hardware, software, and system requirements necessary to perform the tests.

6.3.4.1 Support Hardware.

- a. ARSR-4 system interfaced to the EARTS and MicroEARTS
- b. ATCBI-5 or equivalent beacon interrogator
- c. PC-AT compatible computers
- d. IRES Record Interface Board

6.3.4.2 Support Software.

- a. IRES Analysis Software
- b. EQARS Analysis Software
- c. Current ARSR-4 software build
- d. NAS software build for EARTS and MicroEARTS with ARSR-4 adaptation

6.3.4.3 System Requirements.

Any existing collocated primary radar system operating at the same frequency may be required to stop transmitting (i.e., search down time) for a short period of time, to properly perform false alarm analysis.

7. OT&E OPERATIONAL TESTS.

7.1 CONTROLLER EVALUATIONS.

7.1.1 Purpose.

The purpose of the evaluations is to obtain input from air traffic controllers concerning the suitability and effectiveness of the ARSR-4 operating with the EARTS and MicroEARTS.

7.1.2 Test Objective.

Verify that the ARSR-4, when configured with the EARTS and MicroEARTS, provides at least the level of performance provided by the current radar.

7.1.3 Test Description.

Air traffic controllers will be given operational test questionnaires before the start of tests. The controllers will observe the display of live aircraft and weather in an operational environment and be asked to evaluate the following system performance issues:

- a. General ARSR-4/EARTS and MicroEARTS interface capabilities
- b. Primary radar coverage
- c. Primary radar target detection
- d. Primary radar false alarm rate
- e. Primary radar accuracy
- f. Range and azimuth resolution
- g. BTP code validation and accuracy
- h. BTP splits and false reports
- i. Weather detection and processing

ATC personnel will also be asked to document any system anomalies that are witnessed during the tests. At the conclusion of testing, the controllers will be asked to reach a consensus on system performance. This input will be used to determine the operational effectiveness and suitability of the integrated system.

7.1.4 Test Support Requirements.

The following subsections list or describe the support hardware, software, and system requirements required to perform the tests.

7.1.4.1 Support Hardware.

- a. ARSR-4 system interfaced to the EARTS and MicroEARTS
- b. ATCBI-5 or equivalent beacon interrogator

7.1.4.2 Support Software.

- a. Current ARSR-4 software build
- b. NAS software build for EARTS and MicroEARTS with ARSR-4 adaptation

8. ACRONYMS AND ABBREVIATIONS.

ACP	Azimuth Change Pulse
AGL	Above Ground Level
ARSR-4	Air Route Surveillance Radar Model 4
ARTCC	Air Route Traffic Control Center
ATC	Air Traffic Control
ATCBI	Air Traffic Control Beacon Interrogator
BEXR	Beacon Extractor and Recorder
BTP	Beacon Target Processor
CD-2	Common Digitizer - 2
CDR	Continuous Data Recording
CERAP	Center Enroute Radar Approach
DARC	Direct Access Radar Channel
DRR	Deployment Readiness Review
EARTS	Enroute Automated Radar Tracking System
EQARS	EARTS Quick Analysis of Radar Sites
FAA	Federal Aviation Administration
FAP	Field Adaptable Parameter
FRUIT	False Replies Unsynchronous In Time
IRES	Integrated Radar Evaluation System
LAN	Local Area Network
MicroEARTS	Microprocessor-based Enroute Automated Radar Tracking System
MODE-S	Mode Select Beacon System

MSL	Mean Sea Level
NAS	National Airspace System
nm	nautical miles
ORD	Operational Requirements Document
OT&E	Operational Test and Evaluation
PM	Program Manager
RCS	Radar Cross Section
RLS	Radar Line of Site
RMMS	Remote Maintenance Monitoring Subsystem
RMS	Remote Monitoring Subsystem
rms	root-mean-squared
RTQC	Real-Time Quality Control
SAP	Site Adaptable Parameters
SOCC	Sector Operations Control Center
T&E	Test and Evaluation
TDR	Test Discrepancy Report
VideoBITS	Video Beacon Interrogator Test Set

APPENDIX A
OT&E TEST SCHEDULE

APPENDIX B

**TEST VERIFICATION REQUIREMENTS TRACEABILITY MATRIX
(TVRTM)**

The TVRTM includes the integration and operational requirements that will be verified during testing. This matrix provides traceability from these test plans to FAA operational requirements and the ARSR-4 specification. Included in the matrix are: the requirement number, the OT&E test plan paragraph, NAS-SS-1000 paragraph and volume, ARSR-4 specification paragraph (FAA-E-2763b), a requirements description, and the verification method.

The three verification method types applicable to the ARSR-4/EARTS and ARSR-4/MicroEARTS OT&E are:

- a. **TEST (T)** - A method of verification where performance requirements are verified by measurement during or after the controlled application of functional and/or environmental stimuli. Quantitative measurements are analyzed to determine the degree of compliance with requirements. Testing requires the use of laboratory equipment, data recorders, procedures, and other items or services necessary to complete the test objectives.
- b. **DEMONSTRATION (D)** - A verification method denoting the qualitative determination of properties of an end item including software and/or the use of technical data and documentation. The items being observed are visually illustrated, but not quantitatively measured.
- c. **ANALYSIS (A)** - This verification method consists of comparing hardware and software designs with known scientific and technical principles, procedures, and practices to determine the capability of the design to meet both mission and system requirements.

**ARSR-4/EARTS and ARSR-4/MICROEARTS INTERFACE
TEST VERIFICATION REQUIREMENTS TRACEABILITY MATRIX (TVRTM)**

REQ. #	OT&E Pr.	NAS-SS-1000	VOL.	FAA-E-2763b	REQUIREMENTS	VERIF. METHOD
1	6.1	3.2.1.12.1.6	III	3.5.13	ARSR-4 Inputs and Outputs	T
2	6.1			3.5.13.2	FAA Message Formats	T
3	6.1			3.5.13.2.1	FAA Message Output Buffering and Modem control	T
4	6.1			3.5.9.1.15	Civil and Military Beacon Emergency Processing and Output	T
5	6.1			3.5.15.8.3.2	Search RTQC Target Reporting	T
6	6.1			3.5.15.8.4.1	Beacon RTQC Target Reporting	T
7	6.1			3.5.18.4.4	Status and Alarm Message Reporting	T
8	6.1			3.4.1.17	Weather Data Output	T
9	6.2	3.2.1.2.2.11	III	3.4.1.14a	Timeliness when Collocated with an ATCBI-5	T
10	6.2	3.2.1.1.2.2.13.6a	III	3.4.2.4	Beacon Target Processor Capacity	T, A
11	6.2	3.2.1.2.7.1	I	3.4.1.14	Surveillance Data Response Time	T, A
12	6.2	3.2.1.1.2.2.14	III	3.4.1.8	Target Output Capacities	T
13	6.3	3.2.1.2.7.4a	I	3.4.1.1	Surveillance Coverage	T, A
14	6.3	3.2.1.1.2.2.4.1	III	3.4.1.1	Detection Envelope for Range and Azimuth	T
15	6.3	3.2.1.1.2.2.13.7	III	3.5.10	Primary Radar Target Correlation	T
16	6.3	3.2.1.1.2.2.4.2	III	3.4.1.6	Aircraft Target Detection, False Alarms	T
17	6.3	3.2.1.1.2.2.13.1	III	3.4.2.11	Beacon Probability of Detection	T, A
18	6.3			3.4.2.10	Beacon Target Processor Validation	T, A
19	7.1	3.2.1.1.1.1b	I	3.4.1	Detect Violations of Separation Standards	D
20	7.1	3.2.1.1.1.1a	I	3.4.1	Control Aircraft in/out of Surveillance Coverage Area	D
21	7.1	3.2.1.2.7.4a	I	3.4.1.2	Surveillance Coverage, enroute	D
22	7.1	3.2.1.1.2.2.13	III	3.4.2	Beacon Target Detection	D

APPENDIX C

ATC OPERATIONAL TEST QUESTIONNAIRE

**ARSR-4/MICROEARTS INTERFACE
ATC OPERATIONAL TEST QUESTIONNAIRE**

Evaluator's Name: _____

Position: _____

GENERAL INTERFACE CAPABILITIES

Does the ARSR 4/MicroEARTS system provide the following?

1. The capability to identify, track and control aircraft in your sector or surveillance area?

Yes _____ No _____ Not Observed _____

Comments: _____

2. Observable information on the controller displays? FDB/LDB, MODE C?

Yes _____ No _____ Not Observed _____

Comments: _____

3. The display of weather information?

Yes _____ No _____ Not Observed _____

Comments: _____

4. The capability to allow you to provide required air traffic services?

Yes _____ No _____ Not Observed _____

Comments: _____

6. Aircraft in Coast Track?

Yes _____ No _____ Not Observed _____

Comments: _____

7. Did areas of known poor Radar coverage improve with the ARSR-4 system?

Yes _____ No _____ Not Observed _____

Comments: _____

8. Did you observe limited data blocks and full data blocks in areas and at times you should have?

Yes _____ No _____ Not Observed _____

Comments: _____

PRIMARY RADAR COVERAGE

1. Did you observe targets in all 4 quadrants of the radar coverage envelope (360 degree radius)?

Yes _____ No _____ Not Observed _____

Comments: _____

2. Did you observe targets at all ranges (5-250 NM) from the radar site?

Yes _____ No _____ Not Observed _____

Comments: _____

3. Did you observe altitude readout information at varying heights (up to 100,000 feet or the maximum altitude capability of the test aircraft throughout the coverage area?)

Yes _____ No _____ Not Observed _____

Comments: _____

4. Did you observe any holes (loss of target areas) in the radar coverage area?

Yes _____ No _____ Not Observed _____

Comments: _____

5. Does the radar coverage of the ARSR-4 compare favorably to the radar coverage that was replaced by the ARSR-4?

Yes _____ No _____ Not Observed _____

Comments: _____

PRIMARY RADAR TARGET DETECTION

1. Did you observe primary targets of varying speeds at different altitude and ranges in the areas listed below?

a. Clear Areas (No Clutter)

Yes _____ No _____ Not Observed _____

Comments: _____

b. Clutter areas (sea, terrain, precipitation)

Yes _____ No _____ Not Observed _____

Comments: _____

2. Could you track primary targets through areas of clutter?

Yes _____ No _____ Not Observed _____

Comments: _____

3. Did you observe primary targets of different sizes at different altitudes and ranges in the areas listed below?

a. Clear

Yes _____ No _____ Not Observed _____

Comments: _____

b. Clutter

Yes _____ No _____ Not Observed _____

Comments: _____

4. Was primary target detection better with the ARSR-4 system than with your present system? Please explain.

Yes _____ No _____ Not Observed _____

Comments: _____

PRIMARY RADAR FALSE ALARM RATE

1. Did you observe the presence of false targets?

Yes _____ No _____ Not Observed _____

Comments: _____

2. Could you differentiate false targets from real targets?

Yes _____ No _____ Not Observed _____

Comments: _____

3. Could you determine what the false target was reflected from?

Yes _____ No _____ Not Observed _____

Comments: _____

4. Did you observe a large number of false targets?

Yes _____ No _____ Not Observed _____

Comments: _____

5. Do these false targets have an adverse effect on the following:

a. Tracking a primary target?

Yes _____ No _____ Not Observed _____

Comments: _____

b. Identifying a primary target?

Yes _____ No _____ Not Observed _____

Comments: _____

c. Providing traffic advisories?

Yes _____ No _____ Not Observed _____

Comments: _____

d. Overall control of air traffic ?

Yes _____ No _____ Not Observed _____

Comments: _____

6. Could you recognize false targets caused by terrain and sea clutter?

Yes _____ No _____ Not Observed _____

Comments: _____

7. Could you recognize false targets caused by vehicular traffic and angels?

Yes _____ No _____ Not Observed _____

Comments: _____

8. Could you recognize false targets caused by distributed precipitation?

Yes _____ No _____ Not Observed _____

Comments: _____

9. Could you recognize false targets caused by cellular precipitation?

Yes _____ No _____ Not Observed _____

Comments: _____

PRIMARY RADAR ACCURACY

DID THE ARSR-4 PROVIDE THE INFORMATION NEEDED FOR THE FOLLOWING:

1. To adequately separate two aircraft?

Yes _____ No _____ Not Observed _____

Comments: _____

2. Radar vectoring?

Yes _____ No _____ Not Observed _____

Comments: _____

3. To determine when an aircraft was clear of an obstruction?

Yes _____ No _____ Not Observed _____

Comments: _____

4. To observe a target coincidental with the aircraft's known position?

Yes _____ No _____ Not Observed _____

Comments: _____

5. To determine range and azimuth of a target?

Yes _____ No _____ Not Observed _____

Comments: _____

6. To determine target degradation in the presence of clutter?

Yes _____ No _____ Not Observed _____

Comments: _____

7. Provide for the control and separation of air traffic?

Yes _____ No _____ Not Observed _____

Comments: _____

RANGE AND AZIMUTH RESOLUTION

1. From the demonstration, could you distinguish between two beacon targets that were at the same azimuth and separated by 5 nm?

Yes _____ No _____ Not Observed _____

Comments: _____

2. Did you observe any beacon code or data block swapping?

Yes _____ No _____ Not Observed _____

Comments: _____

3. What was the closest distance observed between two beacon targets (AT DIFFERENT ALTITUDES) at the same range before they merge?

Yes _____ No _____ Not Observed _____

Comments: _____

4. Did this demonstration verify that you were able to meet or exceed operational separation requirements?

Yes _____ No _____ Not Observed _____

Comments: _____

BTP CODE VALIDATION AND ACCURACY

1. Did you always observe a correct response when a target squawked ident?

Yes _____ No _____ Not Observed _____

Comments: _____

2. Did you observe the correct beacon code for each target displayed?

Yes _____ No _____ Not Observed _____

Comments: _____

3. Did you observe any incorrect responses when a target squawked ident?

Yes _____ No _____ Not Observed _____

Comments: _____

4. Did you observe any incorrect beacon codes for the targets displayed?

Yes _____ No _____ Not Observed _____

Comments: _____

BTP SPLIT AND FALSE REPORTS

1. Did you observe any beacon splits during this demonstration?

Yes _____ No _____ Not Observed _____

Comments: _____

2. Did you observe any false beacon reports?

Yes _____ No _____ Not Observed _____

Comments: _____

3. Did you observe any false emergency reports (7500, 7600, or 7700 codes)

Yes _____ No _____ Not Observed _____

Comments: _____

WEATHER DETECTION AND PROCESSING

1. Did you observe the three levels of weather information?

Yes _____ No _____ Not Observed _____

Comments: _____

2. Were you able to distinguish between the different levels?

Yes _____ No _____ Not Observed _____

Comments: _____

3. Was the weather contour well defined?

Yes _____ No _____ Not Observed _____

Comments: _____

