

FEBRUARY 1996

REPORT NO. 96-19

MODIFIED ENHANCED
WOOD PALLET FOR
120MM TANK AMMUNITION
MIL-STD-1660 TESTS

19960802 014

Prepared for:
U.S. Army Armament Research, Development
and Engineering Center
ATTN: AMSTA-AR-AEP
Picatinny Arsenal, NJ 07806-5000

Distribution Unlimited



VALIDATION ENGINEERING DIVISION
SAVANNA, ILLINOIS 61074-9639

DTIC QUALITY INSPECTED 1

AVAILABILITY NOTICE

A copy of this report will be furnished each attendee on automatic distribution. Additional copies or authority for reprinting may be obtained by written request from Director, U.S. Army Defense Ammunition Center and School, ATTN: SIOAC-DEV, Savanna, IL 61074-9639.

DISTRIBUTION INSTRUCTIONS

Destroy this report when no longer needed. Do not return.

Citation of trade names in this report does not constitute an official endorsement.

The information contained herein will not be used for advertising purposes.

DISCLAIMER NOTICE

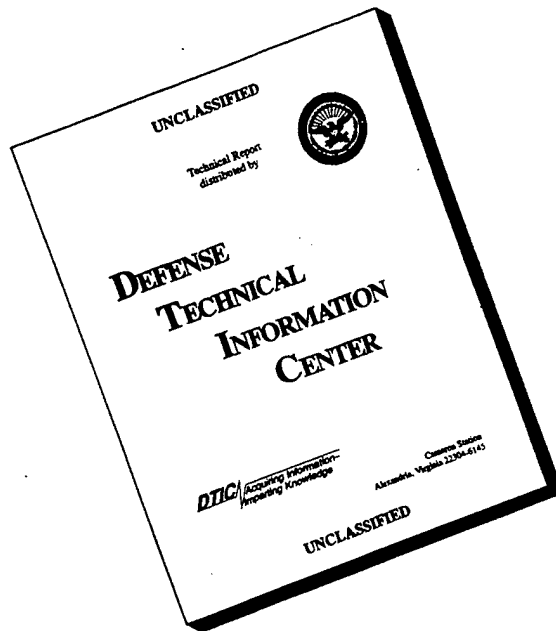

THIS DOCUMENT IS BEST QUALITY AVAILABLE. THE COPY FURNISHED TO DTIC CONTAINED A SIGNIFICANT NUMBER OF PAGES WHICH DO NOT REPRODUCE LEGIBLY.

REPORT DOCUMENTATION PAGE				Form Approved OMB No. 0704-0188	
1a. REPORT SECURITY CLASSIFICATION UNCLASSIFIED		1b. RESTRICTIVE MARKINGS			
2a. SECURITY CLASSIFICATION AUTHORITY		UNLIMITED			
2b. DECLASSIFICATION / DOWNGRADING SCHEDULE					
4. PERFORMING ORGANIZATION REPORT NUMBER(S) 96-19		5. MONITORING ORGANIZATION REPORT NUMBER(S)			
6a. NAME OF PERFORMING ORGANIZATION U.S. Army Defense Ammunition Center and School		6b. OFFICE SYMBOL <i>(if applicable)</i> SIOAC-DEV	7a. NAME OF MONITORING ORGANIZATION		
6c. ADDRESS <i>(City, State, and ZIP Code)</i> ATTN: SIOAC-DEV Savanna, IL 61074-9639		7b. ADDRESS <i>(City, State, and ZIP Code)</i>			
8a. NAME OF FUNDING / SPONSORING ORGANIZATION U.S. Army Armament Research, Development and Engineering Center		8b. OFFICE SYMBOL <i>(if applicable)</i> AMSTA-AR-AEP	9. PROCUREMENT INSTRUMENT IDENTIFICATION NUMBER		
8c. ADDRESS <i>(City, State, and ZIP Code)</i> ATTN: AMSTA-AR-AEP Picatinny Arsenal, NJ 07806-5000		10. SOURCE OF FUNDING NUMBERS			
		PROGRAM ELEMENT NO.	PROJECT NO.	TASK NO.	WORK UNIT ACCESSION NO.
11. TITLE <i>(Include Security Classification)</i> Modified Enhanced Wood Pallet for 120mm Tank Ammunition MIL-STD-1660 Tests					
12. PERSONAL AUTHOR(S) William R. Meyer					
13a. TYPE OF REPORT Final		13b. TIME COVERED FROM TO _____		14. DATE OF REPORT <i>(Year, Month, Day)</i> 1996 February	15. PAGE COUNT
16. SUPPLEMENTARY NOTATION					
17. COSATI CODES			18. SUBJECT TERMS <i>(Continue on reverse if necessary and identify by block number)</i>		
FIELD	GROUP	SUB-GROUP			
19. ABSTRACT <i>(Continue on reverse if necessary and identify by block number)</i> The U.S. Army Defense Ammunition Center and School (USADACS), Validation Engineering Division (SIOAC-DEV), was tasked by the U.S. Army Armament Research, Development and Engineering Center (ARDEC) to conduct MIL-STD-1660 tests on modified enhanced wood pallets for 120mm tank ammunition. Two series of tests were conducted with the second series meeting all MIL-STD-1660, Design Requirements for Ammunition Unit Loads, tests. This report contains details of the tests conducted.					
20. DISTRIBUTION / AVAILABILITY OF ABSTRACT <input checked="" type="checkbox"/> UNCLASSIFIED/UNLIMITED <input type="checkbox"/> SAME AS RPT. <input type="checkbox"/> DTIC USERS			21. ABSTRACT SECURITY CLASSIFICATION UNCLASSIFIED		
22a. NAME OF RESPONSIBLE INDIVIDUAL JEROME H. KROHN			22b. TELEPHONE <i>(Include Area Code)</i> 815-273-8929		22c. OFFICE SYMBOL SIOAC-DEV

U.S. ARMY DEFENSE AMMUNITION CENTER AND SCHOOL
VALIDATION ENGINEERING DIVISION
SAVANNA, IL 61074-9639

REPORT NO. 96-19

MODIFIED ENHANCED WOOD PALLET FOR 120MM TANK AMMUNITION
MIL-STD-1660 TESTS

TABLE OF CONTENTS

PART	PAGE NO.
1. INTRODUCTION	1-1
A. BACKGROUND	1-1
B. AUTHORITY	1-1
C. OBJECTIVE	1-1
D. CONCLUSION	1-1
2. ATTENDEES	2-1
3. TEST PROCEDURES	3-1
4. TEST EQUIPMENT	4-1
5. TEST RESULTS	5-1
6. PHOTOGRAPHS	6-1
7. DRAWINGS	7-1

PART 1

INTRODUCTION

A. BACKGROUND. The U.S. Army Defense Ammunition Center and School (USADACS), Validation Engineering Division (SIOAC-DEV), was tasked by the U.S. Army Armament Research, Development and Engineering Center (ARDEC) to conduct MIL-STD-1660 tests on modified enhanced wood pallets for 120mm tank ammunition. The enhanced wood pallets are being evaluated as an alternative to metal pallets which are nuclear, biological, chemical (NBC) decontaminable.

B. AUTHORITY. This test was conducted IAW mission responsibilities delegated by the U.S. Army Armament, Munitions and Chemical Command (AMCCOM), Rock Island, IL.

C. OBJECTIVE. The objective of these tests was to determine if the enhanced wood pallets could meet MIL-STD-1660 tests.

D. CONCLUSION. Two series of tests were conducted with different methods of restraining the PA116 containers. The first test included eight beveled deck boards nailed to the pallet between the PA116 containers. This design failed during the drop tests with one lateral stringer board failing on the pallet. The second series of tests used a container restraining method similar to what is currently used on the 120mm tank ammunition training round pallets, with substitution of 3/8-inch dimensional lumber for plywood. During this series of tests no problems were encountered with the pallet meeting all MIL-STD-1660 tests.

PART 2
FEBRUARY 1996

ATTENDEES

William R. Meyer
General Engineer
DSN 585-8090
815-273-8090

Director
U.S. Army Defense Ammunition Center
and School
ATTN: SIOAC-DEV
Savanna, IL 61074-9639

Sanjeev Khanna
Mechanical Engineer
DSN 585-8083
815-273-8083

Director
U.S. Army Defense Ammunition Center
and School
ATTN: SIOAC-DES
Savanna, IL 61074-9639

PART 3

TEST PROCEDURES

The test procedures outlined in this section were extracted from MIL-STD-1660, Design Criteria for Ammunition Unit Loads, 8 April 1977. This standard identifies nine steps that a unitized load must undergo if it is to be considered acceptable. The four tests that were conducted on the test pallets are summarized below.

A. SUPERIMPOSED LOAD TEST. The unit load was loaded to simulate a stack of identical unit loads stacked 16 feet high for a period of one hour. This stacking load is simulated by subjecting the unit load to a compression weight equal to an equivalent 16-foot stacking height. The compression load is calculated in the following manner. The unit load weight is divided by the unit load height in inches and multiplied by 192. The resulting number is the equivalent compressive force of a 16-foot-high load.

B. REPETITIVE SHOCK TEST. The repetitive shock test was conducted IAW Method 5019, Federal Standard 101. The test procedure is as follows: The test specimen was placed on, but not fastened to, the platform. With the specimen in one position, the platform was vibrated at 1/2-inch amplitude (1-inch double amplitude) starting at a frequency of approximately 3 cycles per second. The frequency was steadily increased until the package left the platform. The resonant frequency is achieved when a 1/16-inch-thick feeler gage may be momentarily slid freely between every point on the specimen in contact with the platform at some instance during the cycle or a platform acceleration achieved 1 ± 0.1 G. Midway into the testing period, the specimen was rotated 90 degrees and the test continued for the duration. Unless failure occurs, the total time of vibration is two hours when the specimen is tested in one position. When the specimen is tested in more than one position, the total time is three hours.

C. EDGEWISE ROTATIONAL DROP TEST. This test was conducted using the procedures of Method 5008, Federal Standard 101. The procedure for the Edgewise Rotational Drop Test is as follows: The specimen was placed on its skids with one end of the pallet supported on a beam 4-1/2 inches high. The height of the beam was increased, when necessary, to ensure that there was no support for the skids between the ends of the pallet when dropping took place, but was not high enough to cause the pallet to slide on the supports when the dropped end was raised for the drops. The unsupported end of the pallet was then raised and allowed to fall freely to the concrete, pavement, or similar underlying surface from a prescribed height. Unless otherwise specified, the height of drop for level A protection shall conform to the following tabulation:

GROSS WEIGHT NOT EXCEEDING (Pounds)	DIMENSIONS ON ANY EDGE NOT EXCEEDING (Inches)	HEIGHT OF DROP LEVEL A PROTECTION (Inches)
600	72	36
3,000	no limit	24
no limit	no limit	12

D. INCLINE-IMPACT TEST. This test was conducted by using the procedure of Method 5023, Incline-Impact Test of Federal Standard 101. The procedure for the incline-impact test is as follows: The specimen was placed on the carriage with the surface or edge to be impacted projecting at least 2 inches beyond the front end of the carriage. The carriage was brought to a predetermined position on the incline and released. If it is desired to concentrate the impact on any particular position on the container, a 4- by 4-inch timber may be attached to the bumper in the desired position before the test. No part of the timber was struck by the carriage. The position of the container on the carriage and the sequence in which surfaces

and edges were subjected to impacts was at the option of the testing activity and depended upon the objective of the tests. When the test is to determine satisfactory requirements for a container or pack, and, unless otherwise specified, the specimen was subjected to one impact on each surface that has each dimension less than 9.5 feet. Unless otherwise specified, the velocity at time of impact was 7 feet-per-second.

PART 4

TEST EQUIPMENT

A. 120MM Tank Ammunition (Palletized).

- | | |
|------------|---------------|
| 1. Width. | 40-1/8 inches |
| 2. Length. | 44-1/2 inches |
| 3. Height. | 45-1/4 inches |
| 4. Weight. | 2,550 pounds |

PART 5

TEST RESULTS

TEST 1

Description: Modified enhanced wood pallet with eight 1- by- 6-inch beveled boards nailed to the pallet and nested between the container bodies.

- A. COMPRESSION TEST. The compressive load during this test was 12,000 pounds with no problems encountered.

- B. VIBRATION TEST. This test was conducted at 150 rpm for both the lateral and longitudinal orientations with no problems encountered.

- C. EDGEWISE ROTATIONAL DROP TEST. During this test no problems were encountered during the first three drops; however, on the fourth drop parallel to the skids, one lateral stringer board failed on the pallet. This failure was due to columnar loading of the PA116 containers between the pallet posts (see Part 6).

- D. DISASSEMBLY. At the end of testing, the PA116 containers were removed from the pallet. One of the eight beveled deck boards was cracked and separated longitudinally the full length of the board, constituting a major failure (see Part 6).

TEST 2

Description: Modified enhanced wood pallet with 120mm tank ammunition training round pallet design, with 3/8- by 6-inch dimensional lumber substituted for the 3/8-inch plywood.

- A. COMPRESSION TEST. The compressive load during this test was 12,500 pounds with no problems encountered.
- B. VIBRATION TEST. This test was conducted at 145 to 155 rpm for both the lateral and longitudinal orientations with no problems encountered.
- C. EDGEWISE ROTATIONAL DROP TEST. During this test, four drops were completed with no problems encountered.
- D. SLINGING TEST. During the three, two, and one sling lifting tests, no damage occurred to the pallet or top pallet adapter assembly.
- E. DISASSEMBLY. At the end of testing, the PA116 containers were removed from the pallet with minor chipping of the 3/8- by 6-inch dimensional lumber noted.

PART 6

PHOTOGRAPHS



U.S. ARMY DEFENSE AMMUNITION CENTER AND SCHOOL -
SAVANNA, IL

AO317-SCN96-81-1525. This photo shows the design of the first pallet with beveled PA116 restraint boards.
This design failed.



U.S. ARMY DEFENSE AMMUNITION CENTER AND SCHOOL - SAVANNA, IL

AO317-SCN96-81-1527. This photo shows failure of the pallet during the first series of tests.

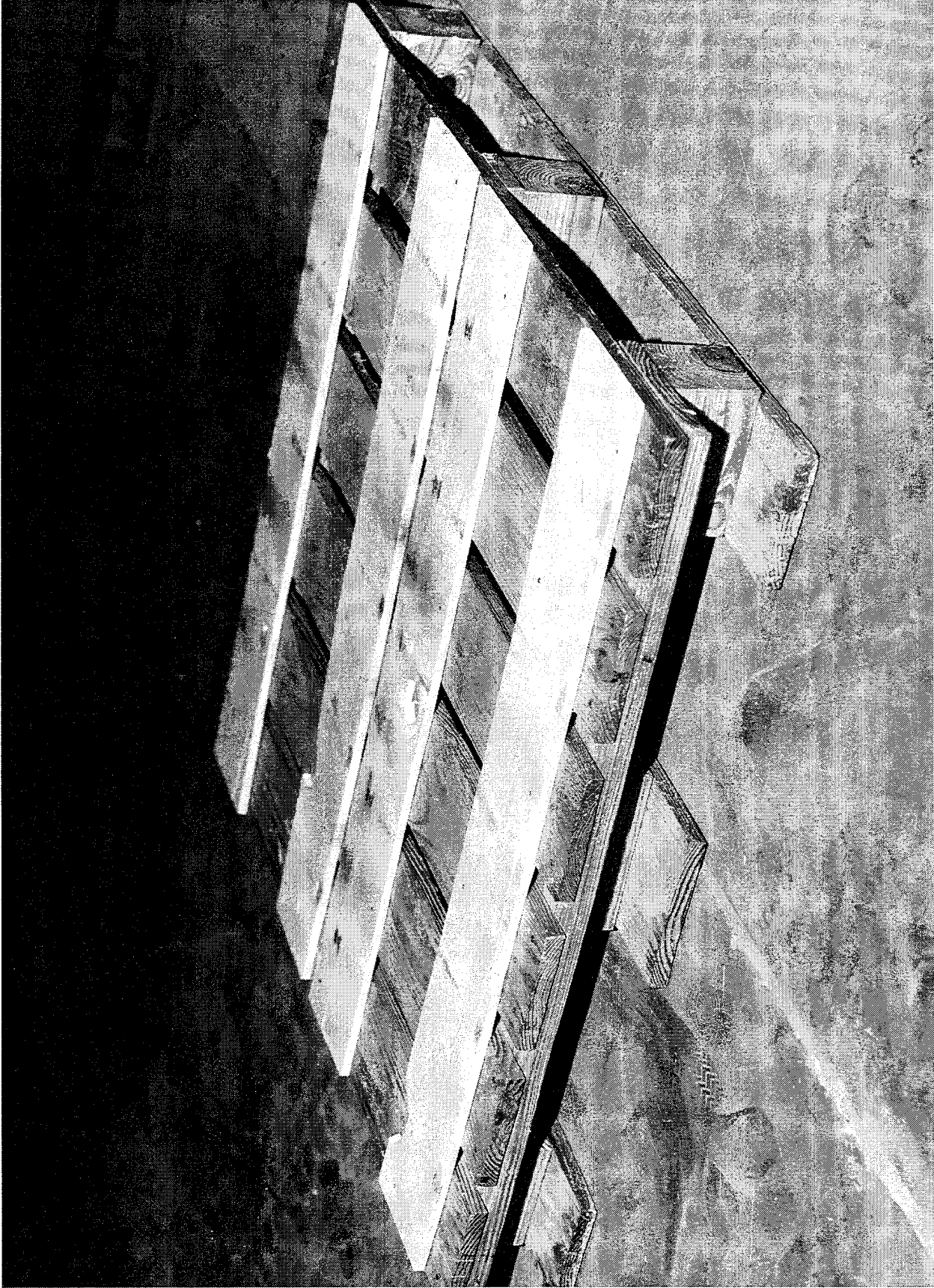

U.S. ARMY DEFENSE AMMUNITION CENTER AND SCHOOL -
SAVANNA, IL

AO317-SCN96-81-1528. This photo shows the pallet design for the second series of tests. This pallet passed all MIL-STD-1660 criteria.

PART 7

DRAWINGS

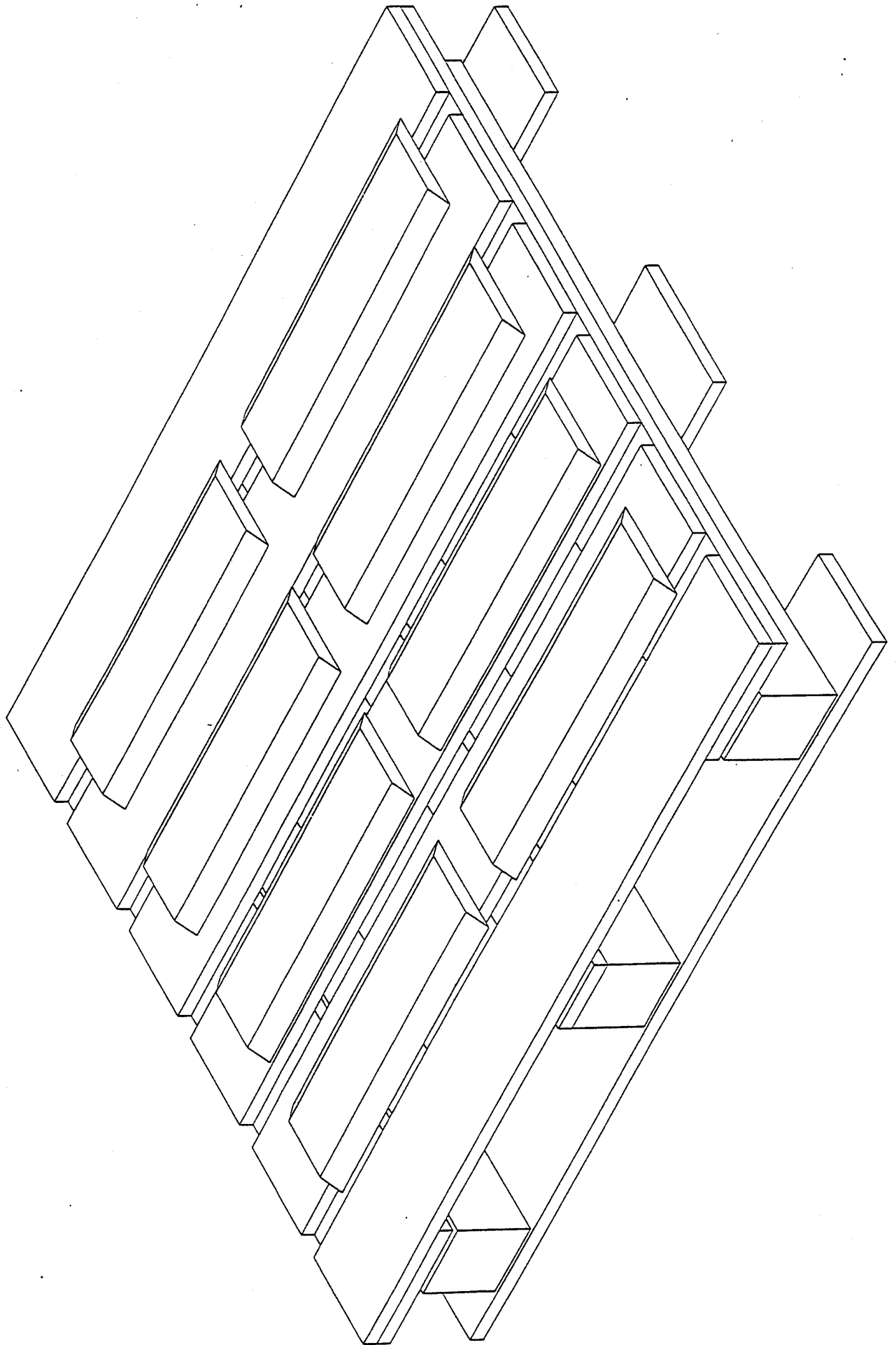

SPECIAL 40" x 44" PALLET

NOTE:

- 1. NAIL THREW DECK BOARDS WITH 5-6d NAILS.

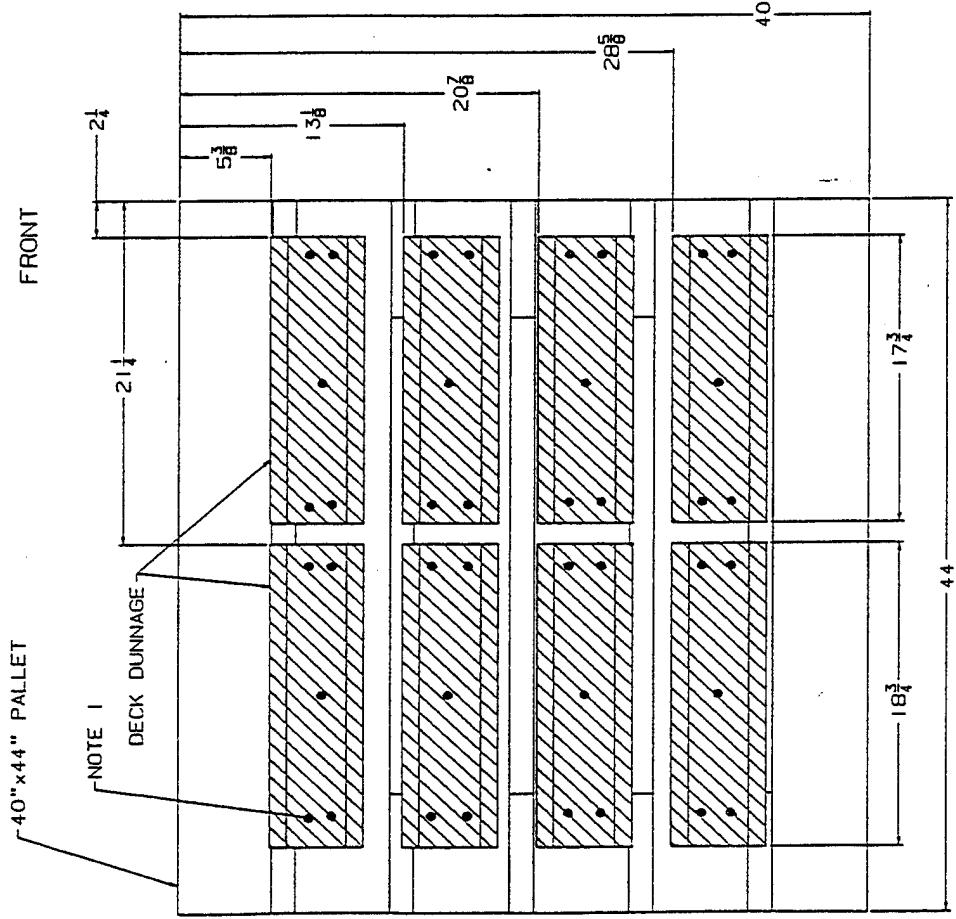

1x6 DECK DUNNAGE

LENGTH

3 1/2

5 1/2

LENGTH	QUANTITY NEEDED
17.75	4
18.75	4

DECK DUNNAGE DETAILS

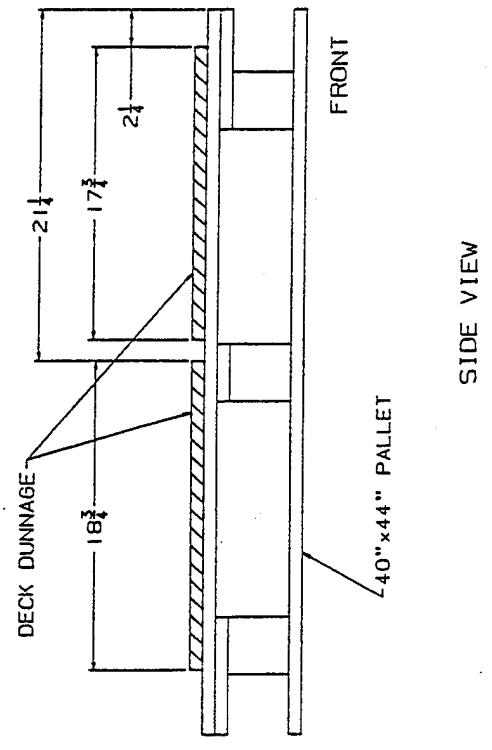

SPECIAL 40" x 44" PALLET
ENHANCED WOOD.

FILE: CK/PAL7B1A

NOTES

1. NAIL THREW DECK BOARDS WITH 6-6d NAILS.
2. VARIFY DIMENTIONS.

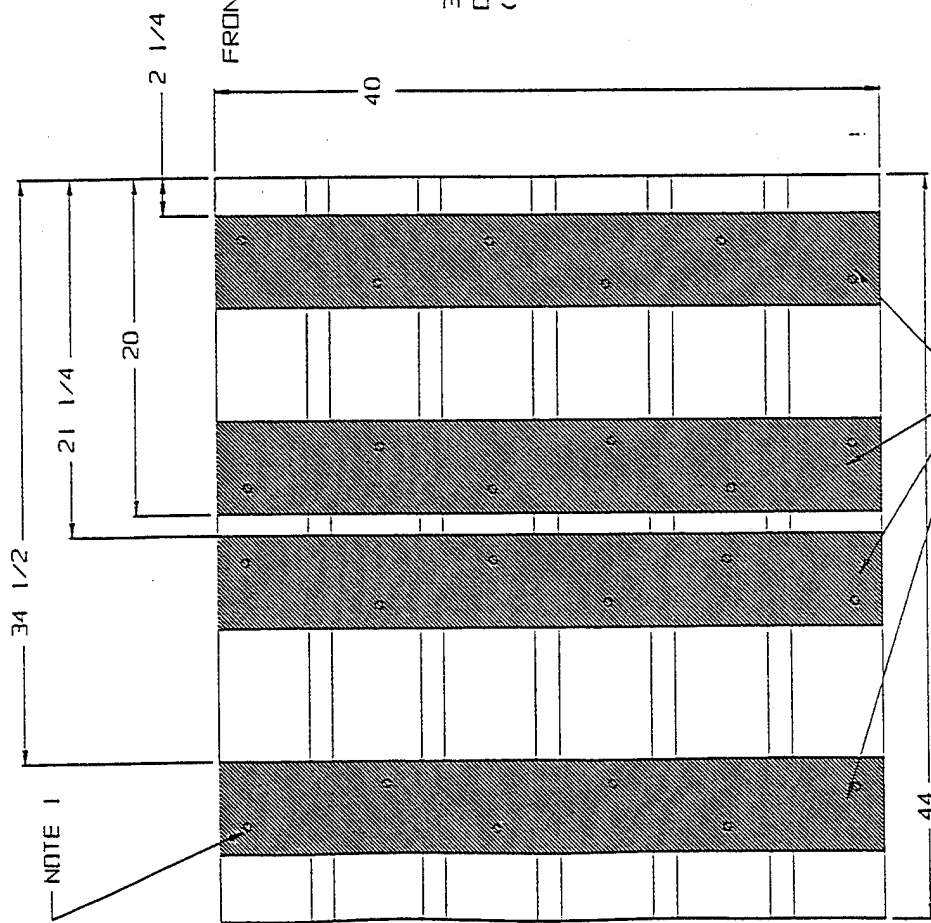

1x6" NOM. DECK BOARDS
PLANNED TO 3/8" x 5-1/2".

TOP VIEW

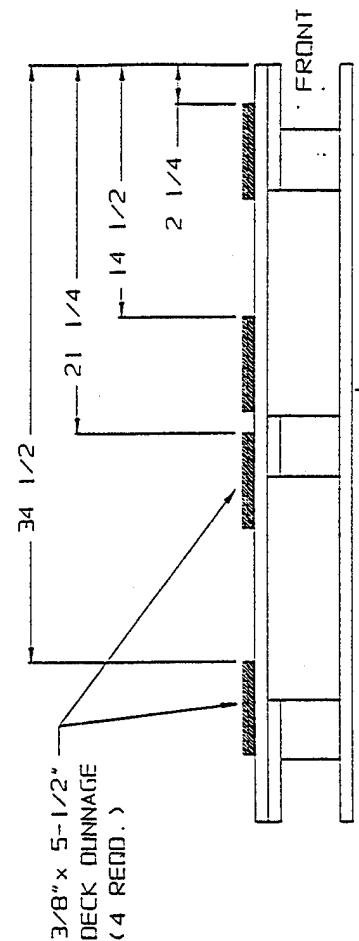

40 x 44 ENHANCED
WOOD PALLET

SIDE VIEW

SPECIAL 40" x 44" PALLET FOR PAI16 CONTAINERS

NOTE:

1. SEE DRAWING SHEET 2 FOR DETAILS OF DECK DUNNAGE.
2. SIDE SUPPORT, USE 1" x 6" NOM., TWO RECD.

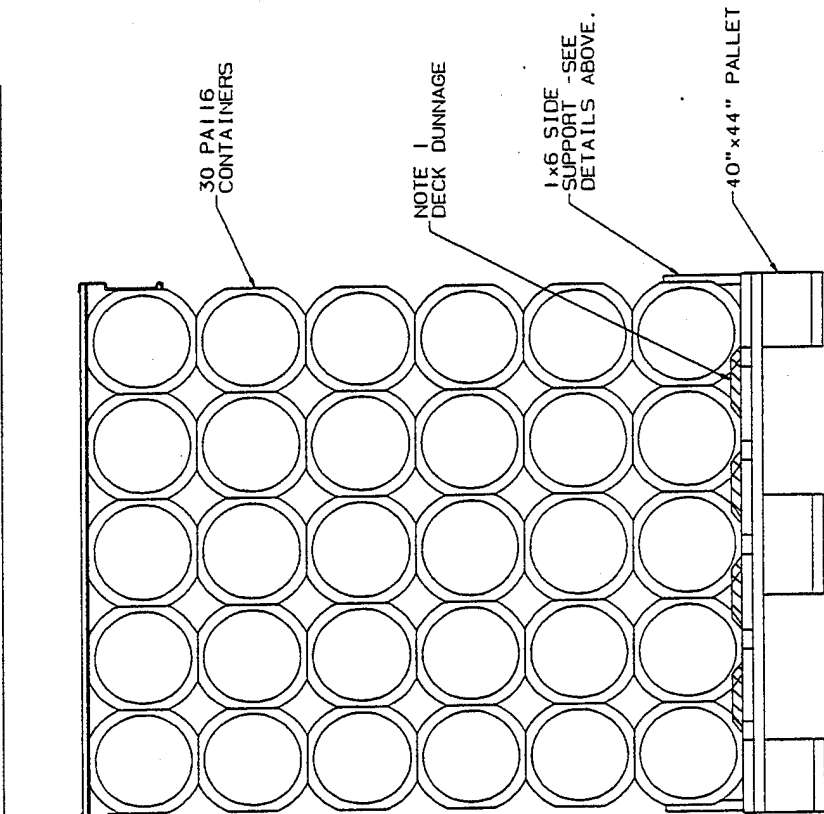
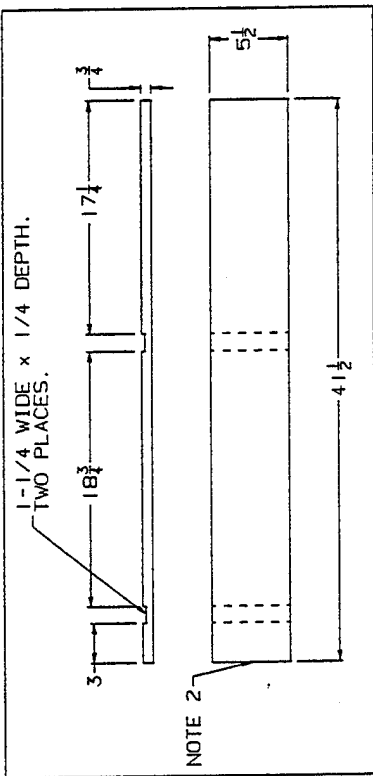

FRONT VIEW

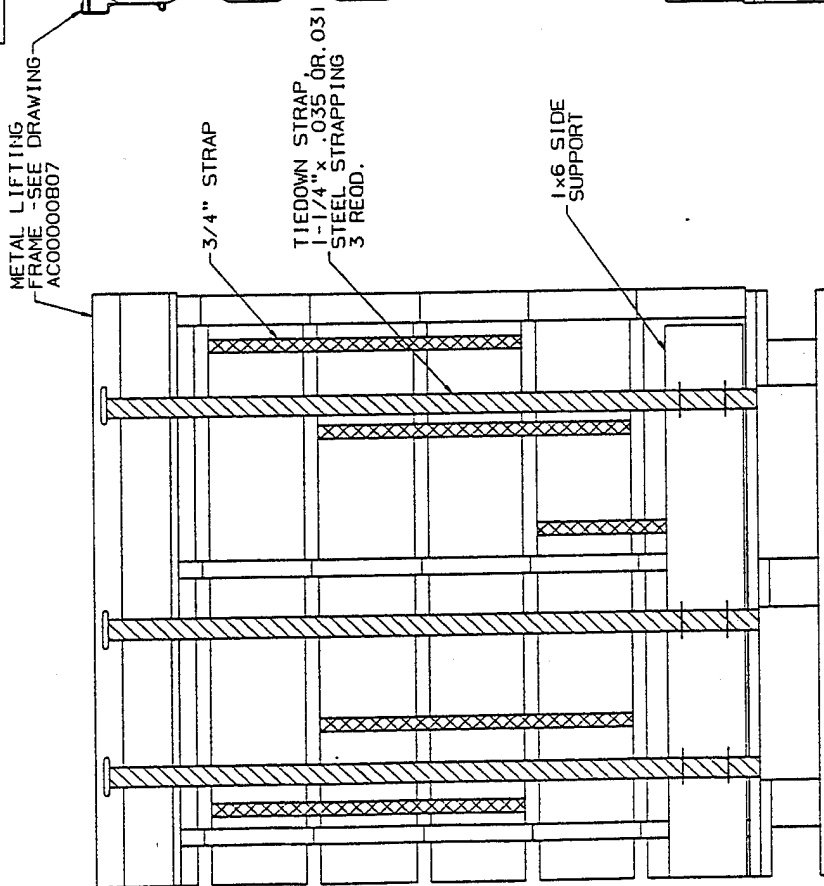

SIDE VIEW

DRAFT

APPENDIX 7C

UNITIZING PROCEDURES FOR
COMPLETE ROUNDS PACKED IN
CYLINDRICAL METAL CONTAINERS
ON 4-WAY ENTRY PALLETS*

PA116 SERIES CONTAINER

INDEX

<u>ITEM</u>	<u>PAGE(S)</u>
PALLET UNIT DATA - - - - -	2
GENERAL NOTES - - - - -	3
UNIT A (W/METAL LIFTING FRAME) - - - - -	4
DUNNAGE DETAILS - - - - -	5
FILLERS AND INSTALLATION PROCEDURES FOR OMITTED CONTAINERS - - - - -	6,7

● THE PROCEDURES DELINEATED WITHIN THIS APPENDIX FOR THE ITEMS SPECIFIED IN THE "PALLET UNIT DATA" CHART ARE FOR MARINE CORPS USE ONLY AND ARE NOT INTENDED TO BE USED BY ANY OTHER SERVICE WITHOUT APPROPRIATE COMMAND APPROVAL

*SEE GENERAL NOTE "H" ON PAGE 3.

NOTICE: THIS APPENDIX CANNOT STAND ALONE BUT MUST BE USED IN CONJUNCTION WITH THE BASIC UNITIZATION PROCEDURES DRAWING 19-48-4079-20PM1002.

DISTRIBUTION STATEMENT A.

APPROVED FOR PUBLIC RELEASE;
DISTRIBUTION IS UNLIMITED.

U.S. ARMY MATERIEL COMMAND DRAWING

APPROVED, U.S. ARMY INDUSTRIAL OPERATIONS COMMAND	DRAFTSMAN		S. KHANNA	
	ENGINEER		S. KHANNA	
	SUPPLY ENGINEERING DIVISION	TRANSPORTATION ENGINEERING DIVISION	VALIDATION ENGINEERING DIVISION	
	AMSTA-AR-ESK	AMSIO-TMJ		
APPROVED BY ORDER OF COMMANDING GENERAL, U.S. ARMY MATERIEL COMMAND	LOGISTICS ENGINEERING OFFICE			
	APRIL 1996			
	CLASS	DIVISION	DRAWING	FILE
REVISION NO.	19	48	4079/ 7C	20PM 1002
SEE THE REVISION LISTING ON PAGE 2				

DO NOT SCALE

DRAFT

PALLET UNIT DATA					
ITEMS INCLUDED		HAZARD CLASS AND DIVISION		APPROX WEIGHT LBS	
NSN	DDIC	GD CLASS	COMP GROUP	UNIT A	UNIT B
				1315-	
01-316-1211	C380	(08)1.2	C	1,888	1,780
01-292-7754	C784	(08)1.2	C	2,038	2,000
01-369-1901	C784	(08)1.2	C	2,038	2,000
01-292-7755	C785	(08)1.2	C	1,763	1,725
01-305-9252	C785	(08)1.2	C	1,763	1,725
01-292-7753	C786	(08)1.2	C	1,763	1,725
01-292-9868	C787	(08)1.2	E	2,038	2,000
01-333-0533	C791	(08)1.2	E	1,988	1,950

● HAZARD CLASSIFICATION DATA CONTAINED IN THE ABOVE CHART IS FOR GUIDANCE AND INFORMATIONAL PURPOSES ONLY. VERIFICATION OF THE SPECIFIED DATA SHOULD BE MADE BY CONSULTING THE MOST RECENT JOINT HAZARD CLASSIFICATION SYSTEM LISTING OR OTHER APPROVED LISTING(S).

GENERAL NOTES

(GENERAL NOTES CONTINUED)

- A. THIS APPENDIX CANNOT STAND ALONE BUT MUST BE USED IN CONJUNCTION WITH THE BASIC UNITIZATION PROCEDURES DRAWING 19-48-4079-20PM1002. TO PRODUCE AN APPROVED UNIT LOAD, ALL PERTINENT PROCEDURES, SPECIFICATIONS AND CRITERIA SET FORTH WITHIN THE BASIC DRAWING WILL APPLY TO THE PROCEDURES DELINEATED IN THIS APPENDIX. ANY EXCEPTIONS TO THE BASIC PROCEDURES ARE SPECIFIED IN THIS APPENDIX.
- B. DIMENSIONS, CUBE AND WEIGHT OF A PALLET UNIT WILL VARY SLIGHTLY DEPENDING UPON THE ACTUAL DIMENSIONS OF THE CONTAINER AND THE WEIGHT OF THE SPECIFIC ITEM BEING UNITIZED.
- C. FOR UNLOADING OF THE ITEMS COVERED BY THIS APPENDIX, CONTACT THE U.S. ARMY DEFENSE AMMUNITION CENTER AND SCHOOL, ATTN: SMCAC-DET, SAVANNA, IL. 61074-9639. FOR STORAGE OF THE ITEMS COVERED BY THIS APPENDIX, CONTACT THE U.S. ARMY DEFENSE AMMUNITION CENTER AND SCHOOL, ATTN: SMCAC-DES, SAVANNA, IL 61074-9639 FOR SPECIFIC PROCEDURAL GUIDANCE.
- D. IF ITEMS COVERED HEREIN ARE UNITIZED PRIOR TO ISSUANCE OF THIS APPENDIX, THE CONTAINERS NEED NOT BE REUNITIZED SOLELY TO CONFORM TO THIS APPENDIX.
- E. FOR DETAILS OF THE PA116 SERIES CONTAINER, SEE U.S. ARMY ARMAMENT RESEARCH AND DEVELOPMENT CENTER DRAWING NO. 9386831.
- CONTAINER DIMENSIONS:-----44-1/2" LONG X 7-3/4" WIDE
X 7-3/4" HIGH.
CONTAINER CUBE:-----1.5 CUBIC FEET (APPROX).
CONTAINER WEIGHT
(WITH ROUND):-----64, 73 OR 75 POUNDS (APPROX).
- F. THE UNITIZATION PROCEDURES DEPICTED HEREIN MAY ALSO BE USED FOR UNITIZING COMPLETE ROUNDS WHEN IDENTIFIED BY DIFFERENT NATIONAL STOCK NUMBERS (NSN) THAN THOSE SHOWN ON PAGE 2, PROVIDED THE ITEM IS PACKED IN THE SAME CONTAINER. THE EXPLOSIVE CLASSIFICATION OF OTHER ITEMS MAY BE DIFFERENT THAN WHAT IS SHOWN.
- G. DIMENSIONS GIVEN FOR DUNNAGE PIECES WILL BE FIELD CHECKED PRIOR TO THEIR ASSEMBLY TO THE PALLET UNIT. CONTAINERS MUST FIT SNUGLY IN THE DUNNAGE ASSEMBLIES. ALSO, DUE TO THE VARIATION OF CONTAINER DIMENSIONS, ADJUSTMENTS MAY BE REQUIRED AS TO THE LOCATION OF CERTAIN PIECES OF DUNNAGE IN A DUNNAGE ASSEMBLY.
- H. THE SPECIAL PALLET WILL BE CONSTRUCTED AND ASSEMBLED IN ACCORDANCE WITH A MILITARY SPECIFICATION MIL-P-15011, STYLE 1, TYPE I, CLASS 1 PALLET WITH THE EXCEPTION THAT THE TOP AND BOTTOM DECK BOARDS WILL BE 44" LONG INSTEAD OF 48". ALL OTHER REQUIREMENTS SPECIFIED WITHIN MIL-P-15011 FOR A STYLE 1, TYPE I, CLASS 1 PALLET WILL APPLY TO THE PALLET SPECIFIED WITHIN THIS DRAWING
- J. THE SPECIAL PALLET DELINEATED IN THE DETAIL ON PAGE 4 NEED NOT HAVE CHAMFERS OR STRAP SLOTS AS SPECIFIED WITHIN MILITARY SPECIFICATION MIL-P-15011 WHEN USED FOR THE UNITIZATION OF THE ITEMS COVERED BY THIS APPENDIX.
- K. FULL IDENTIFICATION MARKINGS IN ACCORDANCE WITH MIL-STD-129-1, TO INCLUDE NSN AND ODDIC, QUANTITY AND NOMENCLATURE, LOT NUMBER, AND GROSS WEIGHT OF THE LOAD, SHALL BE MARKED ON TAGS LOCATED ON OPPOSITE UPPER CORNERS OF THE LOAD.
- L. BAR CODE LABELS ARE REQUIRED ON THE STRAPS OF OPPOSITE CORNERS. SEE MIL-STD-129-1.
- M. THE THICKNESS OF THE SIDE BUFFER PIECES DEPICTED ON PAGE 6 MAY BE ADJUSTED, AS REQUIRED, TO COMPLY WITH THE DIMENSIONAL VARIANCE OF THE PA116 CONTAINERS, SO AS TO COMPLETELY FILL OUT THE PALLET. THE LENGTH DIMENSION OF THE PALLET UNIT AT THE SIDE ASSEMBLIES MUST BE EQUAL TO OR GREATER THAN 40-1/8."
- N. FOR DETAILS OF THE METAL LIFTING FRAME, SEE U.S. ARMY DEFENSE AMMUNITION CENTER AND SCHOOL DRAWING AC200000807 AND MILITARY SPECIFICATION MIL-A-70788.
- O. ALL DUNNAGE SHALL BE REPRESENTATIVE TREATED IN ACCORDANCE WITH MIL-W-71209 AND MIL-P- 71210 AND WITH GENERAL NOTE "X" IN THE BASIC PROCEDURES.

UNATT

(GENERAL NOTES CONTINUED AT RIGHT)

DRAFT

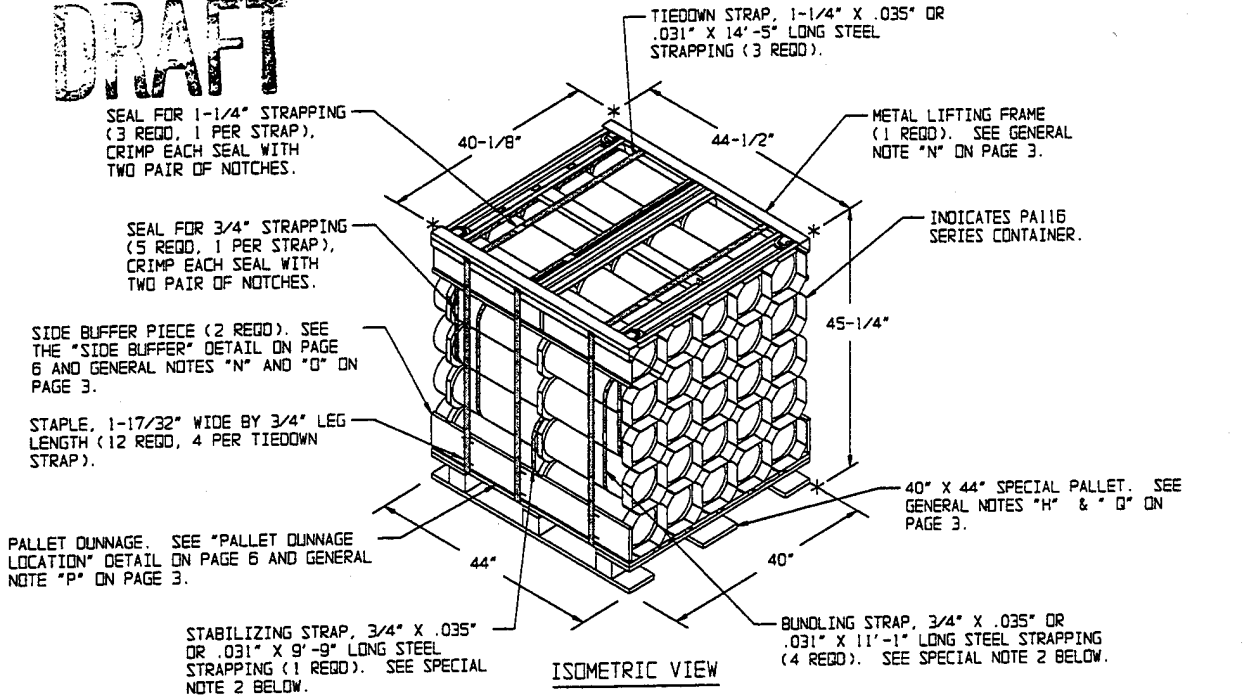

SPECIAL NOTES:

- ALTHOUGH THE CONTAINERS DEPICTED IN THE UNIT LOAD ABOVE ARE CONSTRUCTED WITH INTERLOCKING DEVICES, THE INTERLOCKS WILL NOT FUNCTION PROPERLY UNLESS THE CONTAINERS ARE POSITIONED SO THAT THE "PINS" OF THE INTERLOCKS ARE IN AN UPRIGHT ORIENTATION. THIS ORIENTATION WILL PRECLUDE INTERFERENCE OF THE "PINS" AND THE DECK BOARDS DUNNAGE AND WILL AID IN THE PREVENTION OF CONTAINER MOVEMENT, BOTH Laterally AND LONGITUDINALLY, DURING SHIPMENT OF THE UNIT LOAD.
- BUNDLING STRAPS AND STABILIZING STRAP MUST BE TENSIONED AND SEALED PRIOR TO THE APPLICATION OF THE TIEDOWN STRAPS. ALL STRAPS MUST BE INSTALLED AS CLOSE AS POSSIBLE TO THE CONTAINER RINGS. CAUTION: STRAPS MUST NOT BE ALLOWED TO OVERLAP.
- IF DESIRED, ONE LAYER OF CONTAINERS MAY BE OMITTED FROM THE UNIT LOAD DEPICTED ABOVE. WHEN ONE LAYER OF CONTAINERS IS OMITTED, TIEDOWN STRAP LENGTHS MUST BE DECREASED TO 13'-2" AND TWO BUNDLING STRAPS MUST BE OMITTED (LOCATE REMAINING BUNDLING STRAPS TO SURROUND THE SECOND THROUGH FOURTH LAYERS OF CONTAINERS). THIS WILL RESULT IN AN OVERALL UNIT HEIGHT OF 37'-1/2", A GROSS UNIT WEIGHT OF 1,659 POUNDS, AND A UNIT CUBE OF 38.8 CUBIC FEET. THE UNIT MAY BE MODIFIED AS DESCRIBED ONLY WHEN BEING SHIPPED BY MILVAN OR END OR SIDE OPENING INTERMODAL FREIGHT CONTAINERS. THE DETERMINATION TO REDUCE THE LOAD BY A LAYER FOR TRANSPORTATION WILL BE MADE BY THE RESPONSIBLE COMMAND AND WILL BE BASED UPON ECONOMICS OF TRANSPORTATION AND HANDLING.

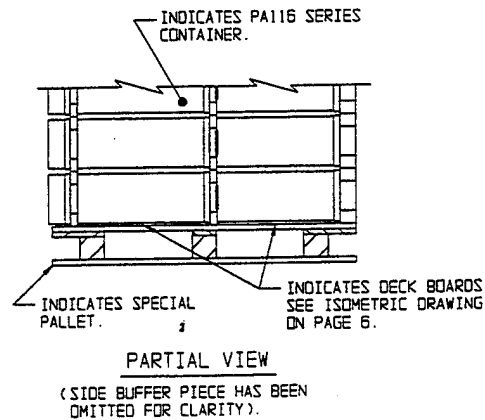

BILL OF MATERIAL (UNIT A)		
NAILS	NO. REGO	POUNDS
6d (2')	12	0.07
SPECIAL PALLET 40" X 44"	1 REGO	77 LBS
STEEL STRAPPING, 3/4"	54.08' REGO	4.83 LBS
SEAL FOR 3/4" STRAPPING	5 REGO	NIL
STEEL STRAPPING, 1-1/4"	43.25' REGO	6.56 LBS
SEAL FOR 1-1/4" STRAPPING	3 REGO	NIL
SIDE BUFFER	3.67 SQ FT REGO	6.30 LBS
STRAP STAPLE, 1-17/32" X 3/4"	12 REGO	NIL
METAL LIFTING FRAME	1 REGO	57 LBS

UNIT DATA

WEIGHT

CUBE	46.8 CUBIC FEET (APPROX)	
CONTAINER, PA116 SERIES	25 EA AT 75 LBS	1,875 LBS (APPROX)
DUNNAGE		76 LBS
PALLET		77 LBS
TOTAL WEIGHT		2,028 LBS (APPROX)

DRAFT

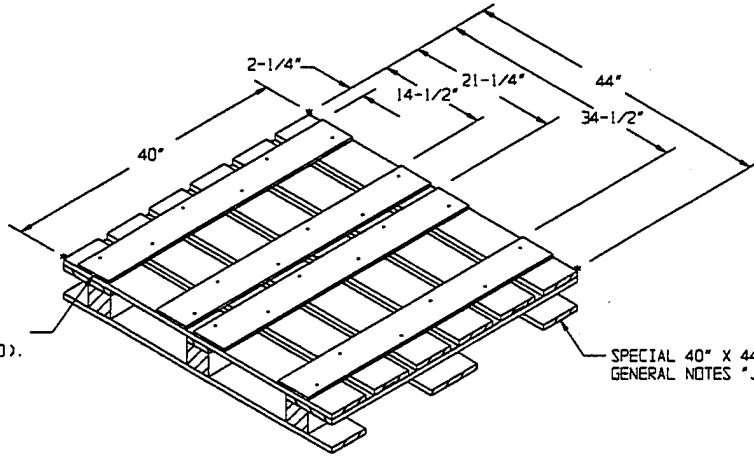

DECK BOARDS DUNNAGE,
3/8" X 5-1/2" X 40" (4 REQD).
NAIL THRU DECK BOARDS
W/6-6d NAILS AND CLINCH.
SEE GENERAL NOTE "D" ON
PAGE 3.

SPECIAL 40" X 44" PALLET. SEE
GENERAL NOTES "J" & "Q" ON PAGE 3.

PALLET DUNNAGE LOCATION

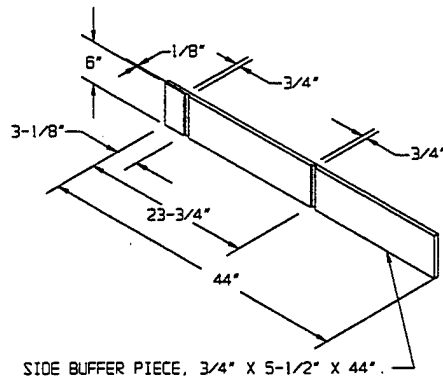

SIDE BUFFER PIECE, 3/4" X 5-1/2" X 44".

SIDE BUFFER

A LEFT HAND PIECE IS DEPICTED.
A RIGHT HAND PIECE IS ALSO REQUIRED.
SEE GENERAL NOTES "N" AND "Q" ON PAGE 3.

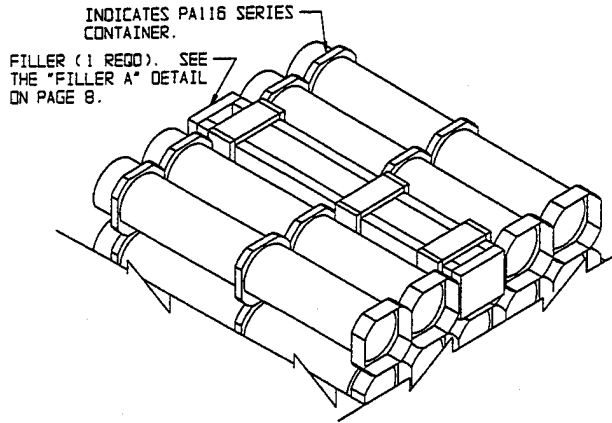

DETAIL A

THIS DETAIL DEPICTS PROCEDURES TO BE USED WHEN A STANDARD PALLET UNIT MINUS ONE CONTAINER IS TO BE UNITIZED. THE FILLER ASSEMBLY DEPICTED MUST BE INSTALLED IN THE MIDDLE OF THE TOP LAYER OF THE PALLET UNIT.

SPECIAL NOTES:

1. WHEN FIVE CONTAINERS ARE TO BE OMITTED FROM A PALLET UNIT, A COMPLETE LAYER OF CONTAINERS MUST BE OMITTED. WHEN FOUR CONTAINERS ARE TO BE OMITTED FROM A PALLET UNIT, A COMBINATION OF FILLER ASSEMBLIES DEPICTED ON PAGE 8 MUST BE USED. WHEN THREE OR LESS CONTAINERS ARE TO BE OMITTED FROM A PALLET UNIT, A COMBINATION OR ONE OF THE FILLER ASSEMBLIES DEPICTED ON PAGE 8 MAY BE USED. ALL FILLER ASSEMBLIES MUST BE INSTALLED IN THE MIDDLE OF THE TOP LAYER OR LAYERS OF A PALLET UNIT.
2. WHEN TWO "FILLER A" ASSEMBLIES ARE USED IN PLACE OF TWO OMITTED CONTAINERS, THE FILLER ASSEMBLIES WILL BE SEPARATED BY AT LEAST ONE CONTAINER TO INSURE PROPER FILLER ASSEMBLY RETENTION AND TO PRECLUDE ASSEMBLY INTERFERENCES.
3. WHEN A "FILLER A" ASSEMBLY IS USED IN CONJUNCTION WITH A "FILLER B" OR "FILLER C" ASSEMBLY, THE "FILLER A" ASSEMBLY MUST BE POSITIONED IN THE SECOND LAYER OF CONTAINERS FROM THE TOP OF THE PALLET UNIT AND MUST HAVE ITS OVERALL HEIGHT REDUCED FROM 7-3/4" TO 6-7/8" FOR PALLET UNIT B, AND FROM 7-1/4" TO 7" FOR PALLET UNIT A. NOTE: 2" X 6" MATERIAL WILL BE SUBSTITUTED FOR THE 2" X 8" MATERIAL RIPPED TO 5-3/4" PIECES USED WHEN THE FILLER ASSEMBLY IS CONSTRUCTED WITH A HEIGHT OF 7" (FOR PALLET UNIT A ONLY).
4. A FOUR LAYER UNIT WILL HAVE TWO BUNDLING STRAPS OMITTED THAT WERE AROUND THE THIRD, FOURTH AND FIFTH LAYERS. THE REMAINING BUNDLING STRAPS WILL SURROUND THE SECOND THROUGH FOURTH LAYERS. A UNIT WITH THREE OR LESS LAYERS, DOES NOT REQUIRE BUNDLING STRAPS. THERE WILL BE NO CHANGES IN THE STABILIZING STRAP REQUIREMENTS.

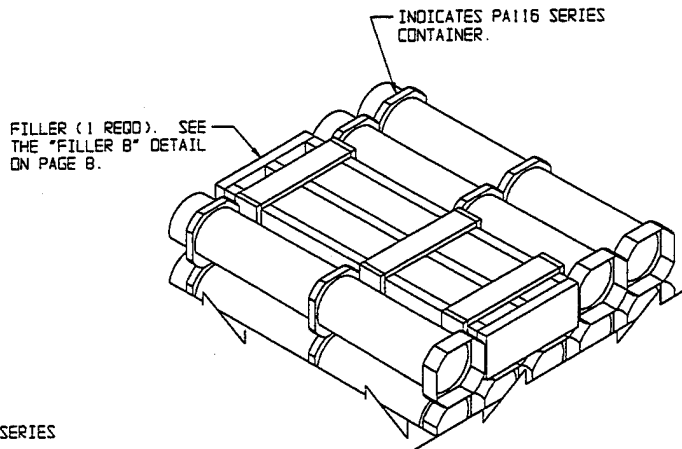

DETAIL B

THIS DETAIL DEPICTS PROCEDURES TO BE USED WHEN A STANDARD PALLET UNIT MINUS TWO CONTAINERS IS TO BE UNITIZED. THE FILLER ASSEMBLY DEPICTED MUST BE INSTALLED IN THE MIDDLE OF THE TOP LAYER OF THE PALLET UNIT.

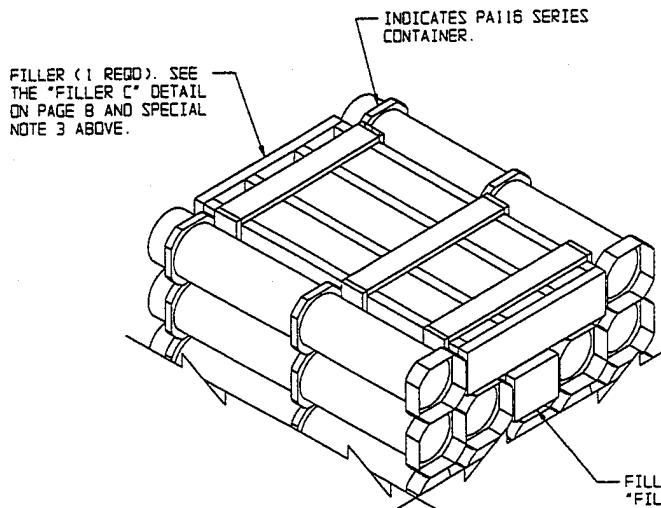

DETAIL C

THIS DETAIL DEPICTS PROCEDURES TO BE USED WHEN A STANDARD PALLET UNIT MINUS FOUR CONTAINERS IS TO BE UNITIZED. THE FILLER ASSEMBLIES DEPICTED MUST BE INSTALLED IN THE MIDDLE OF THE TOP LAYERS OF THE PALLET UNIT.

FILLER (1 REQD). SEE THE "FILLER A" DETAIL ON PAGE 8.

UNRAFT

DRAFT

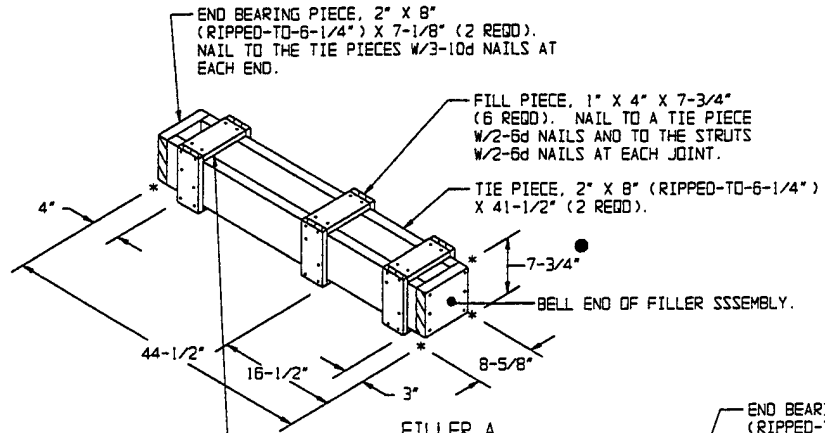

FILLER A

STRUT, 1" X 4" X 7-1/8" (6 REQD). NAIL TO THE TIE PIECES W/2-6d NAILS AT EACH JOINT.

THIS ASSEMBLY IS TO BE USED WHEN ONE OR TWO CONTAINERS ARE TO BE OMITTED FROM A PALLET UNIT OR IN COMBINATION WITH OTHER FILLER ASSEMBLIES. SEE SPECIAL NOTE 2 ON PAGE 7.

● NOTE: THE 7-3/4" DIMENSION IS FOR FILLER ASSEMBLIES CONSTRUCTED FOR PALLET UNIT B (W/O METAL LIFTING FRAME). THIS DIMENSION MUST BE DECREASED TO 7-1/4" FOR FILLER ASSEMBLIES CONSTRUCTED FOR USE IN PALLET UNIT A (W/METAL LIFTING FRAME). OTHER DIMENSIONS MUST BE ADJUSTED AS NECESSARY TO ALLOW FOR THE 1/2" DECREASE IN HEIGHT.

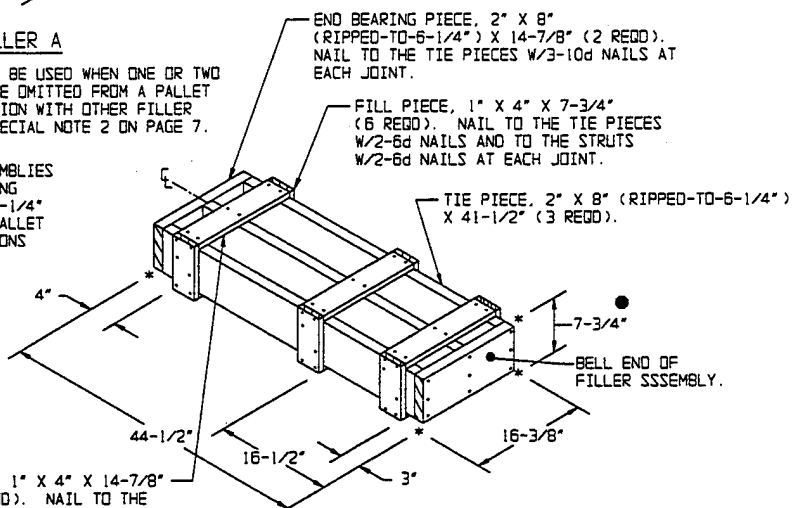

FILLER B

STRUT, 1" X 4" X 14-7/8" (6 REQD). NAIL TO THE TIE PIECES W/2-6d NAILS AT EACH JOINT.

THIS FILLER ASSEMBLY IS TO BE USED WHEN TWO CONTAINERS ARE TO BE OMITTED FROM A PALLET UNIT, OR IN COMBINATION WITH OTHER FILLER ASSEMBLIES.

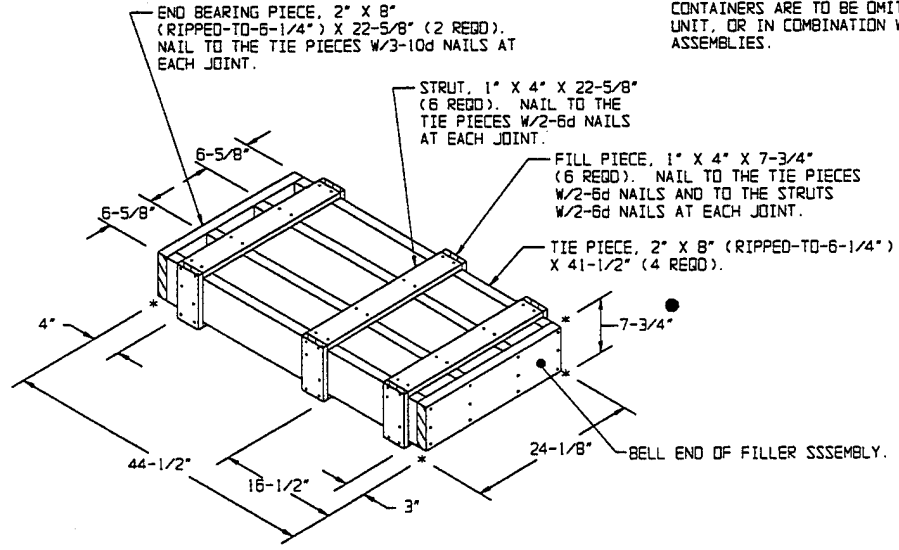

FILLER C

THIS FILLER ASSEMBLY IS TO BE USED WHEN THREE CONTAINERS ARE TO BE OMITTED FROM A PALLET UNIT, OR IN COMBINATION WITH A "FILLER A" ASSEMBLY.