



# U.S. ARMY MEDICAL RESEARCH INSTITUTE OF CHEMICAL DEFENSE

USAMRICD-TR-95-06

Effects of P-aminopropiophenone (PAPP),  
P-aminoheptanoylphenone (PAHP), and  
P-aminooctanoylphenone (PAOP)  
Exposure on Methemoglobin,  
Sulfhemoglobin, Oxyhemoglobin,  
Oxygen Content, Reduced  
Hemoglobin, Oxygen Saturation,  
Carboxyhemoglobin, and Oxygen  
Capacity in Mice

Gary A. Rockwood  
Steven I. Baskin  
James A. Romano, Jr.  
Melanie L. Murrow  
Joel A. Preville  
Robyn B. Lee  
Richard E. Sweeney

DTIC QUALITY INSPECTED 4

19960813 104

April 1996

Approved for public release; distribution unlimited

U.S. Army Medical Research  
Institute of Chemical Defense  
Aberdeen Proving Ground, MD 21010-5425

# DISCLAIMER NOTICE

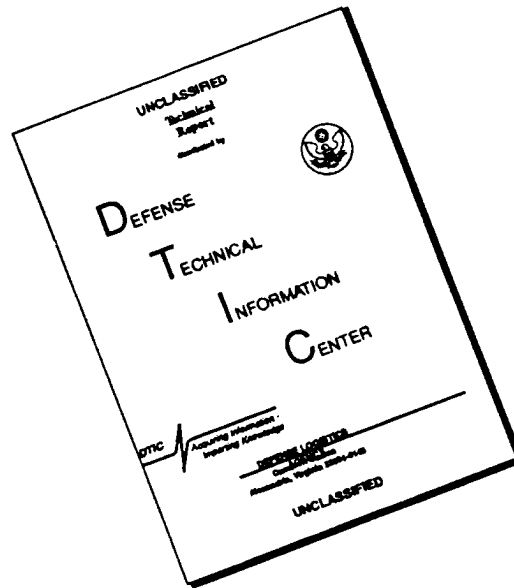

THIS DOCUMENT IS BEST QUALITY AVAILABLE. THE COPY FURNISHED TO DTIC CONTAINED A SIGNIFICANT NUMBER OF PAGES WHICH DO NOT REPRODUCE LEGIBLY.

**DISPOSITION INSTRUCTIONS:**

Destroy this report when no longer needed. Do not return to the originator.

**DISCLAIMERS:**

The findings in this report are not to be construed as an official Department of the Army position unless so designated by other authorized documents.

In conducting the work described in this report, the investigators adhered to the "Guide for the Care and Use of Laboratory Animals," NIH Publication 86-23, revised in 1985.

The use of trade names does not constitute an official endorsement or approval of the use of such commercial hardware or software. This document may not be cited for purposes of advertisement.

# REPORT DOCUMENTATION PAGE

Form Approved  
OMB No. 0704-0188

Public reporting burden for this collection of information is estimated to average 1 hour per response, including the time for reviewing instructions, searching existing data sources, gathering and maintaining the data needed, and completing and reviewing the collection of information. Send comments regarding this burden estimate or any other aspect of this collection of information, including suggestions for reducing this burden, to Washington Headquarters Services, Directorate for Information Operations and Reports, 1215 Jefferson Davis Highway, Suite 1204, Arlington, VA 22202-4302, and to the Office of Management and Budget, Paperwork Reduction Project (0704-0188), Washington, DC 20503.

1. AGENCY USE ONLY (Leave blank)	2. REPORT DATE April 1996	3. REPORT TYPE AND DATES COVERED Final	
4. TITLE AND SUBTITLE Effects of P-Aminopropiophenone (PAPP), P-Aminoheptanoylphenone (PAHP), and P-Amino-octanoylphenone (PAOP) Exposure on Methemoglobin, Sulfhemoglobin, Oxyhemoglobin, Oxygen Content, Reduced Hemoglobin, Oxygen Saturation, Carboxyhemoglobin, And Oxygen Capacity in Mice		5. FUNDING NUMBERS  62787A 3M162787A875 BB	
6. AUTHOR(S) Rockwood, G.A., Baskin, S.I., Romano, J.A., Murrow, M.L., Preville, J.A., Lee, R., and Sweeney, R.			
7. PERFORMING ORGANIZATION NAME(S) AND ADDRESS(ES) U.S. Army Medical Research Institute of Chemical Defense Aberdeen Proving Ground, MD 21010-5425		8. PERFORMING ORGANIZATION REPORT NUMBER	
9. SPONSORING/MONITORING AGENCY NAME(S) AND ADDRESS(ES) U.S. Army Medical Research Institute of Chemical Defense ATTN: MCMR-UV-RC Aberdeen Proving Ground, MD 21010-5425		10. SPONSORING/MONITORING AGENCY REPORT NUMBER  USAMRICD-TR-95-06	
11. SUPPLEMENTARY NOTES			
12a. DISTRIBUTION/AVAILABILITY STATEMENT DISTRIBUTION A: Approved for public release; Distribution is unlimited		12b. DISTRIBUTION CODE	
13. ABSTRACT (Maximum 200 words) Methemoglobin (Mhb) formation is one strategy to counter cyanide (CN) toxicity. Currently available Mhb formers present certain drawbacks and limitations. The purpose of this study was to characterize, in mice, the hematologic effects of the Mhb-forming compound p-aminopropiophenone (PAPP), and two structurally related phenones, p-aminoheptanoylphenone (PAHP) and p-amino-octanoylphenone (PAOP). Although these three phenones have been shown previously to be efficacious against CN, a more complete understanding of their hematologic effects is lacking. Using a hemoximeter, blood samples were obtained -2 to +180 min relative to intramuscular (im) or intraperitoneal (ip) injections. Sodium nitrite (NaNO <sub>2</sub> ) and the appropriate solvents served as the positive and negative controls, respectively. Dose-, time-, route-, and compound-related effects were observed. Mhb and sulfhemoglobin levels tended to increase, whereas levels of those parameters related to oxygen-carrying capacity of the blood, such as oxygen content, oxygen saturation, oxyhemoglobin and reduced hemoglobin were reduced. Small reductions or no measurable changes were observed in carboxyhemoglobin and oxygen capacity. In general, the effects of PAHP and PAOP tended to be longer lasting than those observed with PAPP and NaNO <sub>2</sub> . Furthermore, PAPP and NaNO <sub>2</sub> were equally effective im or ip, whereas PAHP and PAOP showed larger effects when administered ip. Although additional work is needed, these data provide information which will be useful for the successful development of improved anti-CN Mhb formers.			
14. SUBJECT TERMS  Methemoglobin formers, mice, PAPP, PAHP, PAOP		15. NUMBER OF PAGES 44	16. PRICE CODE
17. SECURITY CLASSIFICATION OF REPORT UNCLASSIFIED	18. SECURITY CLASSIFICATION OF THIS PAGE UNCLASSIFIED	19. SECURITY CLASSIFICATION OF ABSTRACT UNCLASSIFIED	20. LIMITATION OF ABSTRACT

## TABLES AND FIGURES

TABLE	PAGE
1.....	9
2.....	10
3.....	11
4.....	12
5.....	13
6.....	14

FIGURE	
1.....	17
2.....	18
3.....	19
4.....	20
5.....	21
6.....	22
7.....	23
8.....	24
9.....	25
10.....	26
11.....	27
12.....	28
13.....	29
14.....	30
15.....	31
16.....	32
17.....	33

The highly toxic nature of cyanide (CN) and its derivatives has been recognized for many years. Not surprisingly, attempts to identify an antidote to counter CN toxicity also have a long history. One strategy to counter cyanide toxicity is to administer compounds which form methemoglobin (MHb), a molecule for which cyanide has a greater affinity than hemoglobin. Although MHb cannot transport oxygen, properly monitored induced (i.e., acquired) methemoglobinemia can be effective in mitigating and/or reversing CN effects (ATSDR, 1993).

The successful application of MHb formers such as nitrites and methylene blue against CN actually predates the identification of MHb as a common mechanism of action. More than a century ago, Pedigo demonstrated the efficacy of amyl nitrite against CN poisoning in dogs (Pedigo, 1888). Mladoveanu and Gheorghiu (1929) subsequently reported that dogs recovered from otherwise lethal levels of CN when sodium nitrite was administered soon after CN exposure, and Geiger (1932) presented important evidence for clinical efficacy of methylene blue against CN poisoning (see also Hanzlik and Richardson, 1934). It was proposed by Hug (1933a,b) and Wendel (1933) that the antagonistic action of these substances against CN was directly linked to their demonstrated ability to form MHb in the blood *in vivo* (Combemale, 1891; Haldane *et al.*, 1897). Extensive experimental and clinical corroboration and elaboration of the nitrite data have resulted in the long-standing inclusion of both amyl nitrite and sodium nitrite in the Eli Lilly Cyanide Antidote Package. Chen and colleagues demonstrated enhanced effectiveness of MHb formers (e.g., amyl nitrite, sodium nitrite) when combined with a sulfur donor such as sodium thiosulfate (Chen *et al.*, 1934; Chen and Rose, 1952; see also Baskin *et al.*, 1992). With respect to methylene blue, further work indicates that although a (weak) MHb former (Nadler *et al.*, 1934; Marrs *et al.*, 1989), the pharmacological characteristics of methylene blue render it more effective as a treatment to reduce dangerously high levels of methemoglobin (Wendel, 1939; Kiese *et al.*, 1972; Hall *et al.*, 1986; Smith, 1991).

CN has been used as an offensive weapon during wartime, and, largely due to its rapid toxicity onset, its cost and relative ease to manufacture, and the varied methods of its application, CN remains a viable threat as a chemical warfare agent (Compton, 1987; United States Senate Hearings, 1989; McKay and Vogel, 1992). Attempts in the United States to systematically exploit the MHb-forming properties of compounds extend back to WWII. In 1944, Vandenberg *et al.* identified a phenone, p-aminopropiophenone (PAPP), as a potent, relatively nontoxic MHb former in dogs, superior to nitrites and other MHb formers with regard to MHb formation. This finding was followed by a succession of reports from Bodansky and colleagues who exploited the MHb-forming properties of PAPP, demonstrating impressive protection in dogs and rodents against CN toxicity (Jandorf and Bodansky, 1946; Tepperman *et al.*, 1946; Bodansky and Guttman, 1947). Subsequent research highlighted the MHb-forming ability and low toxicity of PAPP in human volunteers (Beutler and Mikus, 1961; Paulet *et al.*, 1963), and provided noteworthy evidence that PAPP may have practical medical and/or military applications (Bodansky and Hendley, 1946; Tepperman *et al.*, 1946; Beutler and Mikus, 1961; see also Baskin and Fricke, 1992).

More recently, two phenones structurally related to PAPP, *viz.* p-aminoheptanoylphenone (PAHP) and p-aminooctanoylphenone (PAOP), have been identified as potentially useful MHb-forming anti-CN agents (Scharf *et al.*, 1992; Rockwood *et al.*, 1994). This work emerges against a background in which limitations and drawbacks of existing MHb formers used to counter CN toxicity (e.g., nitrites) are acknowledged and highlighted (Hanzlik and Richardson, 1934;

Frankenberg, 1982; van Heijst *et al.*, 1987; van Heijst and Meredith, 1990). For example, both amyl nitrite and sodium nitrite form MHb in experimental animals (Chen *et al.*, 1933; Chen and Rose, 1952), but neither shows impressive MHb formation in humans (Paulet, 1954; Bastian and Mercker, 1959; Kiese and Weger, 1969). In addition, side-effects in humans following the administration of amyl nitrite as well as sodium nitrite (e.g., vasomotor and cardiac perturbations, hypotension) have been reported (Paulet, 1954; Kiese and Weger, 1969; Frankenberg and Sorbo, 1975; Frankenberg, 1982). Therefore, to provide an initial evaluation of other MHb formers which have shown efficacy against CN, the current focus is to profile and compare in the mouse hematologic changes produced by PAPP, PAHP and PAOP. Although some information describing MHb patterns in the mouse after the administration of PAPP has been reported (e.g., Abbanat and Smith, 1964; Smith *et al.*, 1967), a more complete evaluation of other hematologic parameters following PAPP has, to date, not been made available. Furthermore, since only scant information on PAHP and PAOP has been published (Bright and Marrs, 1983; Bright, 1987; D'Mello, 1987; Scharf *et al.*, 1992), the present study will allow for an extensive comparison among PAPP, PAHP and PAOP along multiple hematologic parameters. It is anticipated that this comparison will assist in the identification of those characteristics which render certain MHb formers more efficacious than others against both lethal and sublethal exposure to CN or CN-like compounds.

## METHODS

### Subjects

Male CD-1 Swiss albino mice (N=306; mean weight=27.3 ± 0.2 g) served as subjects, and were maintained under an AAALAC-accredited animal care and use program. Prior to experimentation, animals were group-housed in polycarbonate cages (N ≤ 10/cage), in a temperature- (22° ± 2° C) and humidity-controlled (40-70%) housing facility with a 12-hr light/dark lighting cycle with no twilight (lights on at 0600 hr). Food and water were available *ad libitum* until testing commenced. During testing (3 hr maximum), animals did not have access to food or water.

### Sampling Procedure

Each subject was removed from its home cage and placed individually into a Plexiglas and wood restraining device, with its tail remaining exposed. This technique allowed for rapid and accurate tail vein sampling and required minimal animal handling. For each sample, approximately 40-50 µl of blood was collected from the tip of the tail into a heparinized capillary tube, and then promptly introduced into an OSM3 Hemoximeter (Radiometer America, Inc.) for analysis. Blood samples were obtained at -2, +2, +15, +30, +60, +120 and + 180 min relative to injection, as described below. The first sample provided baseline information. Subsequent time points were selected to encompass the anticipated time of action of the test compounds, and to provide an adequate number of intermediate measurements for ascertaining temporal patterns of hematologic changes. Between samples, animals were placed individually into a polycarbonate

cage lined with woodchip bedding.

## Testing

Each animal was assigned randomly to a treatment group as detailed in Table 1. Hematologic parameters were measured following a single intramuscular (im) or intraperitoneal (ip) injection of p-aminopropiophenone (PAPP), p-aminoheptanoylphenone (PAHP), p-aminooctanoylphenone (PAOP), or appropriate vehicle control (see Figure 1). Drug doses were selected on the basis of compound efficacy against a 2 MLD CN challenge and/or preliminary behavioral data (Rockwood *et al.*, 1992; Scharf *et al.*, 1992; Rockwood, Murrow, Preville, Baskin and Romano, unpublished observations). The prototypic MHb former sodium nitrite ( $\text{NaNO}_2$ ; 100 mg/kg) served as the positive control, and it or its vehicle (normal saline) was administered either im or ip. Injections were administered in a volume of 0.5 ml/kg (im) or 1.0 ml/kg (ip). Group sample size ranged from 5-15, with most groups comprised of 8-10 mice. Restricted drug availability limited the sample size of the smallest groups. In addition, because of the lack of hematologic effects of PAOP administered im, only 2-4 animals were tested in these groups. The effects of these compounds on the following hematologic parameters are reported: methemoglobin (MHb), sulfhemoglobin (SHb)<sup>1</sup>, carboxyhemoglobin (HbCO), oxyhemoglobin ( $\text{HbO}_2$ ), oxygen capacity ( $\text{O}_2\text{CAP}$ ), oxygen content ( $\text{O}_2\text{CT}$ ), reduced hemoglobin (RHb), and oxygen saturation (SAT). MHb, HbCO,  $\text{HbO}_2$ , RHb and SAT are expressed as % of total hemoglobin; SHb is expressed as a concentration, mmol/L; and  $\text{O}_2\text{CAP}$  and  $\text{O}_2\text{CT}$  are expressed as content of oxygen bound to hemoglobin, in volume %.

## Data Analyses

For each compound and its respective vehicle control, a repeated measures analysis of variance (ANOVA) was performed, with Time as the repeated measure (SAS Institute, Cary, NC). Simple main effects analyses and/or Newman-Keuls tests were conducted as appropriate. All tests were considered statistically significant at the  $P < 0.05$  level.

<sup>1</sup>Based on OSM3 methodology using absorbances, SHb measures are reported in mmol/L. It should be cautioned that because a standard reference method for SHb determination is not currently available, these units are relative, and may not actually reflect *exact* SHb levels. However, the accuracy of the *patterns* of SHb in the samples measured by the OSM3 remains intact.

## RESULTS

MHb formation following phenone administration was accompanied by a proportional increase in SHb and decreases in HbO<sub>2</sub>, O<sub>2</sub>CAP, O<sub>2</sub>CT, RHb and SAT. These effects were not uniform across phenones, but were compound-, route-, dose- and/or time-dependent. In addition, no significant HbCO was detected in any of the animals in this study.

The hematologic effects of PAHP and PAOP were larger when administered ip versus im. However, this pattern was not evident with either PAPP or NaNO<sub>2</sub>. Furthermore, by the end of the 3-hr test period, the hematologic effects produced by PAHP and PAOP were often still present, while those produced by PAPP and NaNO<sub>2</sub> were no longer evident. A summary of effects as a function of drug and route is presented in Table 2. Details of the effects of these compounds on the various hematologic parameters measured are described in the text below and/or depicted in Figures 2-13. Note that because of generally similar hematologic patterns, PAPP and NaNO<sub>2</sub> data are reported (but not pooled) together, and PAHP and PAOP data are reported (but not pooled) together. Furthermore, since either small or no effects were observed with O<sub>2</sub>CAP and HbCO, respectively, no additional results for these parameters are provided in the text. However, these data are presented in Figures 14-17. Finally, unless otherwise noted, peak drug effects occurred 15-30 min post-injection.

### **PAPP and NaNO<sub>2</sub>**

**MHb and SHb.** For MHb, peak values ranged from 16-53% for PAPP and were observed at 33% for NaNO<sub>2</sub>. For SHb, peak values ranged from 0.042-0.106 mmol/L for PAPP and were observed at 0.067 mmol/L for NaNO<sub>2</sub> (see Figures 2 and 3).

**HbO<sub>2</sub> and O<sub>2</sub>CT.** Lowest HbO<sub>2</sub> levels ranged from 6-18% for PAPP and were observed at 20% for NaNO<sub>2</sub>. For O<sub>2</sub>CT, lowest levels ranged from 1.0-3.6 volume % for PAPP and were observed at 3.5 volume % for NaNO<sub>2</sub> (see Figures 4 and 5).

**RHb and SAT.** Lowest RHb levels occurred at 15-60 min post-injection, with lowest levels ranging from 42-60% for PAPP, and were observed at 42% for NaNO<sub>2</sub>. For SAT, lowest levels occurred 2-30 min post-injection, with lowest levels ranging from 10-15% for PAPP and were observed at 25% for NaNO<sub>2</sub> (see Figures 6 and 7).

### **PAHP and PAOP**

**MHb and SHb.** MHb and SHb levels for both PAHP and PAOP were significantly elevated in ip-treated animals. In im-treated animals, only PAHP produced a significant elevation. In those groups exhibiting elevated MHb levels, peak values were observed 30-60 min post-injection. For PAHP, peak values ranged from 3-8% for im-treated animals, whereas for ip-treated animals, peak values ranged from 34-55%. For PAOP, peak values ranged from 25-42% in ip-treated animals. In those groups exhibiting elevated SHb levels, peak values were observed at 30-120 min post-injection. For PAHP, peak values ranged from 0.016-0.020 mmol/L in im-treated animals, and 0.048-0.089 mmol/L in ip-treated animals. For PAOP, peak values in ip-treated animals ranged from .055-.074 mmol/L (see Figures 8 and 9).

**HbO<sub>2</sub> and O<sub>2</sub>CT.** HbO<sub>2</sub> and O<sub>2</sub>CT levels were significantly reduced in ip- but not im-

treated animals. For PAHP, lowest levels were observed at 30-120 min post-injection, whereas for PAOP, lowest levels were observed at 15-60 min post-injection. For HbO<sub>2</sub>, lowest levels ranged from 5-11% for PAHP, and 9-15% for PAOP. For O<sub>2</sub>CT, lowest levels ranged from 1.1-2.1 volume % for PAHP, and 1.9-3.1 volume for PAOP (see Figures 10 and 11).

**RHb and SAT.** RHb and SAT levels were significantly reduced in ip- but not im-treated animals. For RHb, lowest levels were observed at 30-60 min post-injection, whereas for SAT, lowest levels were observed at 30-180 min and 15-30 min post-injection for PAHP and PAOP, respectively. For RHb, lowest levels ranged from 39-55 % for PAHP, and 47-60 % for PAOP. For SAT, lowest levels ranged from 12-17% for PAHP, and 13-19% for PAOP (see Figures 12 and 13).

## DISCUSSION

The MHb-forming phenones PAPP, PAHP, and PAOP each provide significant dose-dependent protection in mice against a 2 X MLD CN challenge (Scharf *et al.*, 1992; unpublished observations). This pattern of protection against CN, combined with the pattern of hematologic changes observed in the present study, strongly suggests that elevated MHb levels are required for these compounds to show efficacy against CN. This notion is further supported by the observation that PAOP produces MHb and affords significant protection against CN when administered ip (Scharf *et al.*, 1992). However, when administered im, PAOP neither initiates MHb formation nor provides protection against a 2 X MLD CN challenge (Rockwood, Murrow, Preville and Nealley, unpublished observations; present study). Although these findings are strongly suggestive, our data cannot eliminate the possibility that the phenones tested in the present study are efficacious against CN in ways other than, or in addition to, MHb formation. That is, these compounds may produce concurrent or partially overlapping events, with MHb the most easily identified/quantified. Hence, MHb formation is generally regarded as the most likely candidate for mechanism of action of these phenones against CN. For example, in addition to being a MHb former, PAPP is also a vasodilator. It is therefore feasible that enhanced blood flow may allow for endogenous mechanisms to more readily metabolize and/or reduce the concentration of CN, with the result being demonstrable efficacy of MHb formers against CN (Holmes and Way, 1982; Way, 1984; Baskin and Fricke, 1992; Scharf *et al.*, 1992).

It is not surprising that certain relationships appear among the various hematologic parameters measured in this study. Those parameters which measure red blood cell oxidation of oxygen-carrying hemoglobin, such as MHb and SHb, were elevated by the phenones tested. Conversely, levels of those parameters which measured the concomitant changes in oxygen-carrying capacity, such as HbO<sub>2</sub>, O<sub>2</sub>CAP, O<sub>2</sub>CT, RHb and SAT, decreased. Measured levels of species such as HbCO, which were not directly related to the effects of these particular drugs, did not change significantly.

The observation of significant and time-related elevated SHb levels which paralleled MHb changes deserves some additional consideration. It is generally accepted that SHb formation, unlike MHb formation, is permanent until normal red cell replacement (Beutler, 1977;

Smith, 1991). Patterns of SHb changes in the current study suggest temporary changes which diminish as a function of time, dose, drug and route of administration, a finding generally similar to that described in other reports (Nomura, 1977; Martin *et al.*, in press). It is likely that the general term SHb actually describes several species, and that our SHb measure describes a combination, including one or more which are reversible.

Interestingly, Smith (1991) considers the occurrence of temporary SHb changes as a possible indication of an ongoing hemolytic process, e.g., Heinz body formation. Indeed, PAPP has been reported to be hemolytic in large doses, i.e., doses large enough to result in greater than 40-50% MHB (Beutler and Mikus, 1961; Paulet *et al.*, 1963). Although it is not known whether PAPP or the other MHB-forming compounds used presently are in fact hemolytic, an explanation for observed temporary SHb elevation based on some form of a hemolytic process cannot be ruled out. It must be pointed out, however, that (a) methemoglobinemia *per se* does not result in hemolysis (Beutler, 1969), (b) other MHB-forming compounds, such as NaNO<sub>2</sub>, are not hemolytic at doses producing comparable MHB levels as those doses of PAPP which do promote hemolysis (Beutler and Mikus, 1961), and (c) considering the high levels of MHB reported in those studies in which hemolysis was observed, it is likely that at least at those doses of the compounds which produced low to moderate MHB levels, hemolysis would be minimal, if present at all. Further clarification of this issue is warranted.

By itself, methemoglobinemia can be effective against CN, but logical and practical steps may be taken to counter certain limitations and to enhance the likelihood of a favorable outcome following CN toxicity. For example, though interest in induced MHB as a means to counter CN toxicity continues, it is often cautioned that the induction of methemoglobinemia may itself be harmful due to a compromised ability of blood to transport oxygen (Bright, 1987). Chemically induced methemoglobinemia, if unmonitored, can indeed place the subject in a potentially life-threatening situation. However, careful monitoring of MHB status can minimize the possibility of attaining dangerous MHB levels (ATSDR, 1993). The goal of this study was to identify MHB-forming compounds which result in the lowest protective levels of MHB against potential CN exposure, estimated to be 10-15% (Frankenberg, 1982; Bright, 1987; Canfield *et al.*, 1987; D'Mello, 1987). Research using animals as well as humans suggests that it is unlikely these MHB levels would result in significant physiological, hematological or behavioral impairment (Tepperman *et al.*, 1946; Paulet *et al.*, 1963; Rockwood *et al.*, 1992). In addition, this estimate for an optimal MHB range takes into account not only actual protection against CN, but also the presence/absence of side-effects associated with methemoglobinemia and/or the specific characteristics of the individual MHB former.

It was recognized early that methemoglobinemia is a condition which provides a pharmacological scavenger for CN and is not a means to biotransform CN to a less toxic form. That is, MHB-bound CN is not deactivated but, rather, is rendered ineffective due to its strong affinity for the MHB molecule. However, once the MHB molecule is reduced to hemoglobin, the CN can become unbound, and can jeopardize oxygen utilization. Therefore, combinations of strategies (i.e., MHB-former, followed by a sulfur donor, such as sodium thiosulfate) are recommended as most effective (Chen *et al.*, 1935; Chen and Rose, 1952).

This study characterizes time-, dose- and route-dependent hematologic changes of three MHB formers known to be highly efficacious against CN toxicity. Our data suggest that the

more lipophilic compounds have a longer time course of action. Furthermore, the relative inability of PAHP and PAOP to become hematologically active after im injections deserves further attention, as there is apparent drug sequestration or other means by which these drugs are not readily available when administered via this route. Overall, information from this study should further aid in the rational development of these or similar compounds as possible therapeutic or prophylactic anti-CN drugs available for medical and/or military application.

## ACKNOWLEDGEMENTS

The authors wish to thank Anita Finger and Eric Nealley for expert special assistance with this project.

TABLE 1. Experimental compounds and doses.

COMPOUND	VEHICLE <sup>a</sup>	DOSE (mg/kg) <sup>b</sup>
PAPP	5% EtOH/PEG 200	9.4, 11.7, 14.1, 18.8, 37.5
PAHP	5% EtOH/PEG 200	15.6, 31.2, 62.5, 125.0
PAOP	PEG 200	30.0, 45.0, 52.5, 60.0, 90.0
NaNO <sub>2</sub> <sup>c</sup>	SALINE	100

<sup>a</sup> Groups of animals which received vehicle only served as negative controls.

<sup>b</sup> See text for dose selection rationale.

<sup>c</sup> Animals receiving NaNO<sub>2</sub> served as positive controls.

TABLE 2. Summarized effects of each Mhb former on eight blood parameters as a function of drug and route of administration. Relative to control values, † indicates a significant increase, ‡ indicates a significant decrease, and - indicates no change. All significant changes were dose-dependent (see Figures and Text for additional details).

PARAMETER ▶	MHb		SHb		HbO <sub>2</sub>		O <sub>2</sub> CT		SAT		RHb	
	IM	IP	IM	IP	IM	IP	IM	IP	IM	IP	IM	IP
COMPOUND ▼												
PAPP	†	†	†	†	‡	‡	‡	‡	‡	‡	‡	‡
PAHP	†	†	†	†	-	‡	-	‡	-	‡	-	‡
PAOP	-	†	-	†	-	‡	-	‡	-	‡	-	‡
NaNO <sub>2</sub>	†	†	†	†	‡	‡	‡	‡	‡	‡	‡	‡

TABLE 3. Summary of statistical analyses for PAPP.  
 S=Significant; NS=Not Significant; T=Time; D=Dose  
 (These designations are applicable to Tables 3-6.)

	IM	IP
MHb	DOSE: S	DOSE: S
	T X D: S	T X D: S
SHb	DOSE: S	DOSE: S
	T X D: S	T X D: S
HbO <sub>2</sub>	DOSE: S	DOSE: S
	T X D: S	T X D: S
O <sub>2</sub> CT	DOSE: S	DOSE: S
	T X D: S	T X D: S
RHb	DOSE: S	DOSE: S
	T X D: S	T X D: S
SAT	DOSE: S	DOSE: S
	T X D: S	T X D: S
HbCO	DOSE: NS	DOSE: NS
	T X D: NS	T X D: S
O <sub>2</sub> CAP	DOSE: S	DOSE: S
	T X D: S	T X D: S

TABLE 4. Summary of statistical analyses for NaNO<sub>2</sub>.

	IM	IP
MHb	DOSE: S	DOSE: S
	T X D: S	T X D: S
SHb	DOSE: S	DOSE: S
	T X D: S	T X D: S
HbO <sub>2</sub>	DOSE: S	DOSE: S
	T X D: S	T X D: S
O <sub>2</sub> CT	DOSE: S	DOSE: S
	T X D: S	T X D: S
RHb	DOSE: S	DOSE: S
	T X D: S	T X D: S
SAT	DOSE: NS	DOSE: S
	T X D: S	T X D: S
HbCO	DOSE: NS	DOSE: NS
	T X D: NS	T X D: S
O <sub>2</sub> CAP	DOSE: S	DOSE: S
	T X D: S	T X D: S

TABLE 5. Summary of statistical analyses for PAHP.

	IM	IP
MHb	DOSE: S	DOSE: S
	T X D: S	T X D: S
SHb	DOSE: S	DOSE: S
	T X D: NS	T X D: S
HbO <sub>2</sub>	DOSE: NS	DOSE: S
	T X D: NS	T X D: S
O <sub>2</sub> CT	DOSE: NS	DOSE: S
	T X D: NS	T X D: S
RHb	DOSE: NS	DOSE: S
	T X D: NS	T X D: S
SAT	DOSE: NS	DOSE: S
	T X D: NS	T X D: S
HbCO	DOSE: NS	DOSE: NS
	T X D: NS	T X D: NS
O <sub>2</sub> CAP	DOSE: S	DOSE: S
	T X D: NS	T X D: S

TABLE 6. Summary of statistical analyses for PAOP.

	IM	IP
MHb	DOSE: NS	DOSE: S
	T X D: S	T X D: S
SHb	DOSE: NS	DOSE: S
	T X D: NS	T X D: S
HbO <sub>2</sub>	DOSE: NS	DOSE: S
	T X D: NS	T X D: S
O <sub>2</sub> CT	DOSE: NS	DOSE: S
	T X D: NS	T X D: S
RHb	DOSE: NS	DOSE: S
	T X D: NS	T X D: S
SAT	DOSE: NS	DOSE: S
	T X D: NS	T X D: NS
HbCO	DOSE: NS	DOSE: NS
	T X D: NS	T X D: NS
O <sub>2</sub> CAP	DOSE: NS	DOSE: S
	T X D: S	T X D: S

## FIGURE CAPTIONS

- Figure 1.** Chemical structures of the MHb-forming phenones PAPP, PAHP and PAOP.
- Figure 2.** MHb and SHb levels in mice treated with PAPP, as a function of time, dose and route of administration.
- Figure 3.** MHb and SHb levels in mice treated with NaNO<sub>2</sub>, as a function of time and route of administration.
- Figure 4.** HbO<sub>2</sub> and O<sub>2</sub>CT levels in mice treated with PAPP, as a function of time, dose and route of administration.
- Figure 5.** HbO<sub>2</sub> and O<sub>2</sub>CT levels in mice treated with NaNO<sub>2</sub>, as a function of time and route of administration.
- Figure 6.** RHb and SAT levels in mice treated with PAPP, as a function of time, dose and route of administration.
- Figure 7.** RHb and SAT levels in mice treated with NaNO<sub>2</sub>, as a function of time and route of administration.
- Figure 8.** MHb and SHb levels in mice treated with PAHP, as a function of time, dose and route of administration.
- Figure 9.** MHb and SHb levels in mice treated with PAOP, as a function of time, dose and route of administration.
- Figure 10.** HbO<sub>2</sub> and O<sub>2</sub>CT levels in mice treated with PAHP, as a function of time, dose and route of administration.
- Figure 11.** HbO<sub>2</sub> and O<sub>2</sub>CT levels in mice treated with PAOP, as a function of time, dose and route of administration.
- Figure 12.** RHb and SAT levels in mice treated with PAHP, as a function of time, dose and route of administration.
- Figure 13.** RHb and SAT levels in mice treated with PAOP, as a function of time, dose and route of administration.
- Figure 14.** HbCO and O<sub>2</sub>CAP levels in mice treated with PAPP, as a function of time, dose and route of administration.
- Figure 15.** HbCO and O<sub>2</sub>CAP levels in mice treated with NaNO<sub>2</sub>, as a function of time, dose and route of administration.
- Figure 16.** HbCO and O<sub>2</sub>CAP levels in mice treated with PAHP, as a function of time, dose and route of administration.
- Figure 17.** HbCO and O<sub>2</sub>CAP levels in mice treated with PAOP, as a function of time, dose and route of administration.

Fig 1

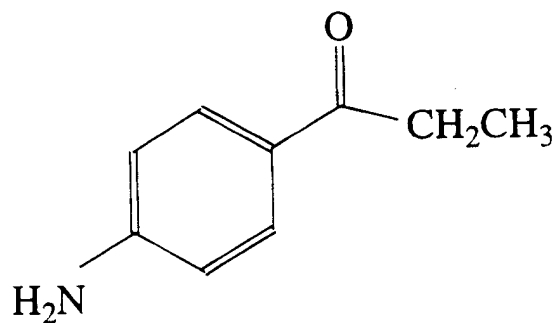

PAPP

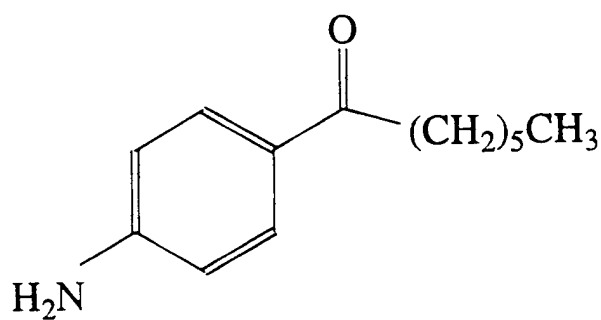

PAHP

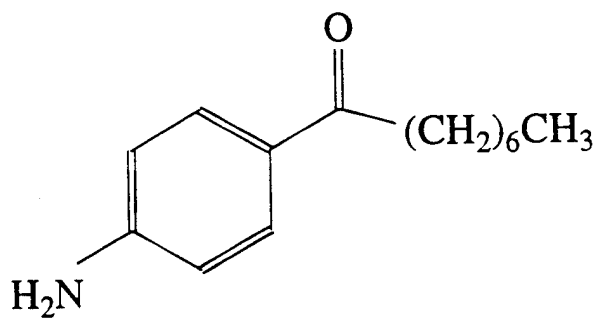

PAOP

Fig 2

# PAPP

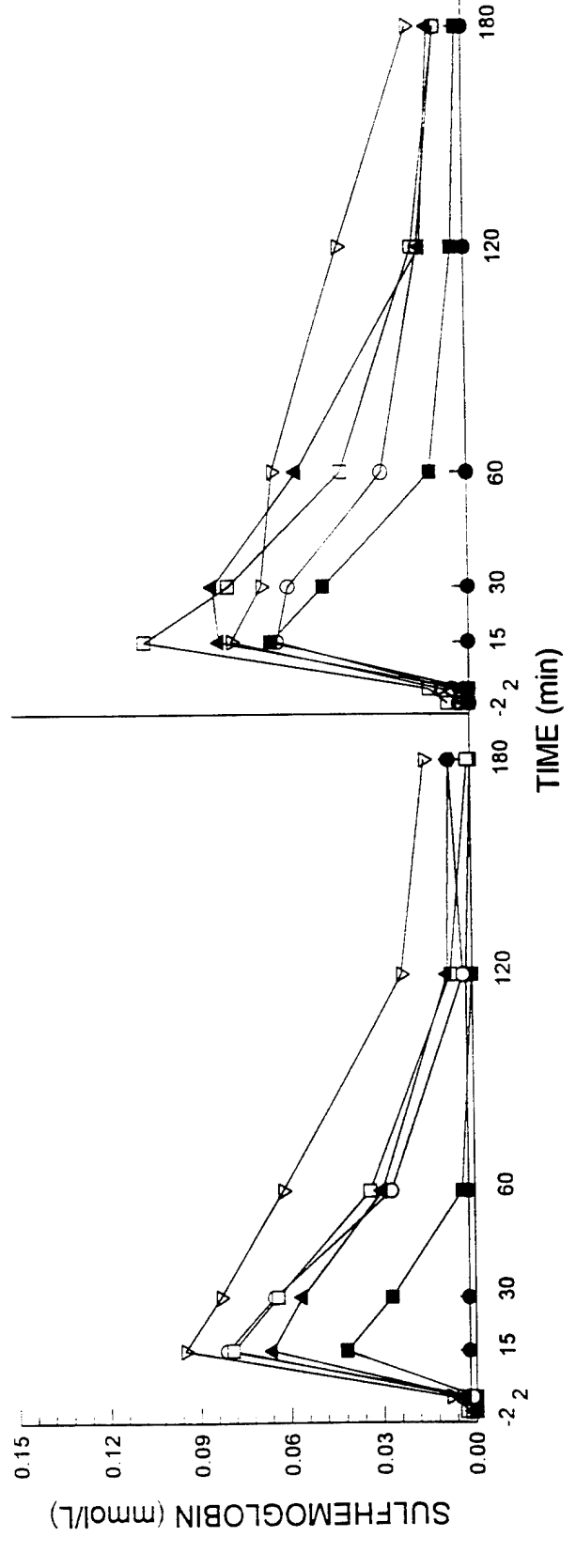
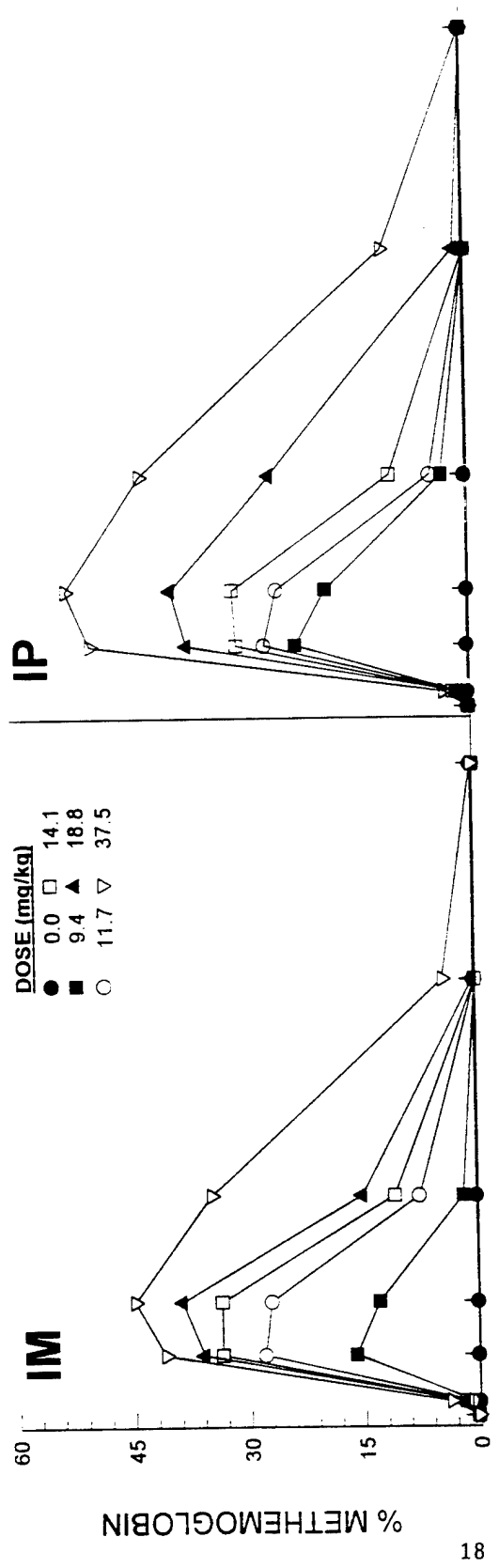

# NaNO<sub>2</sub>

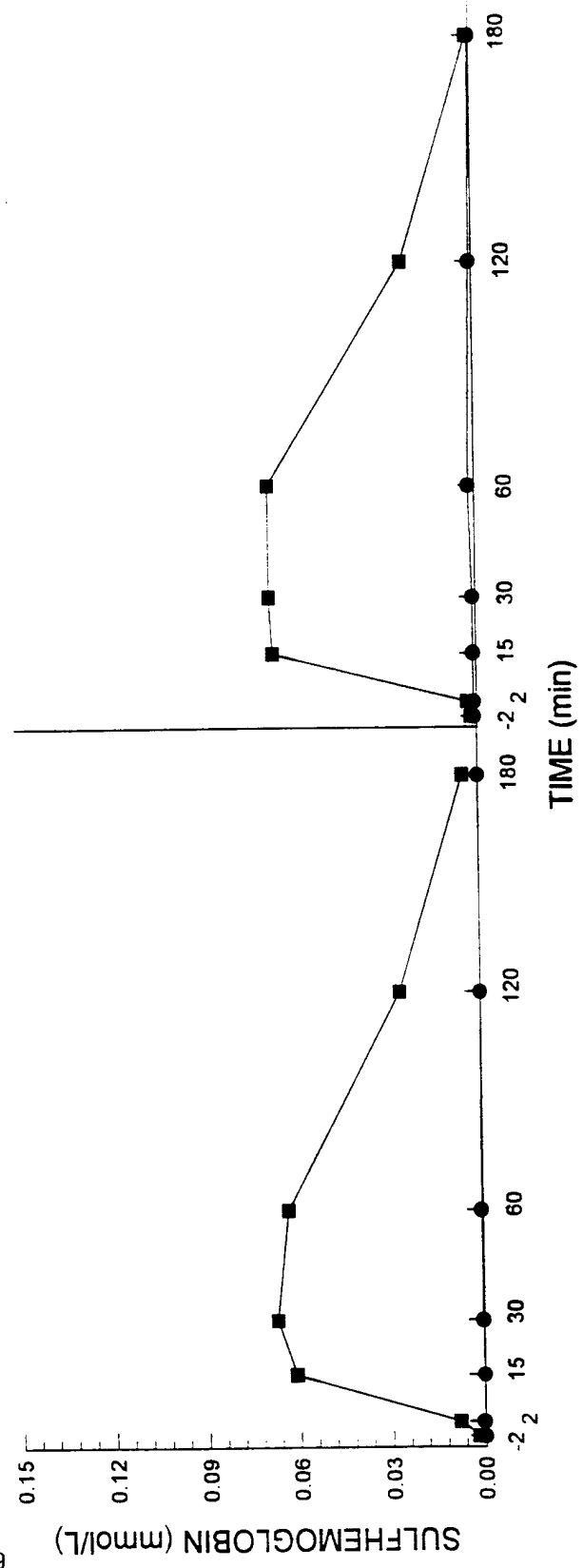
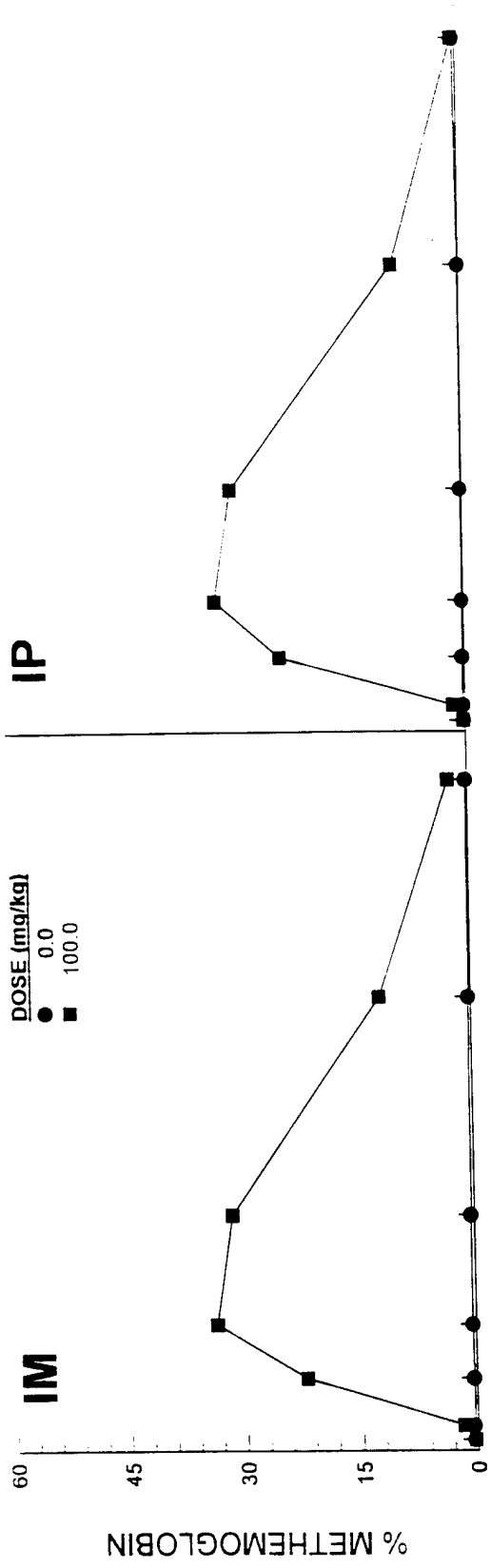

# PAPP

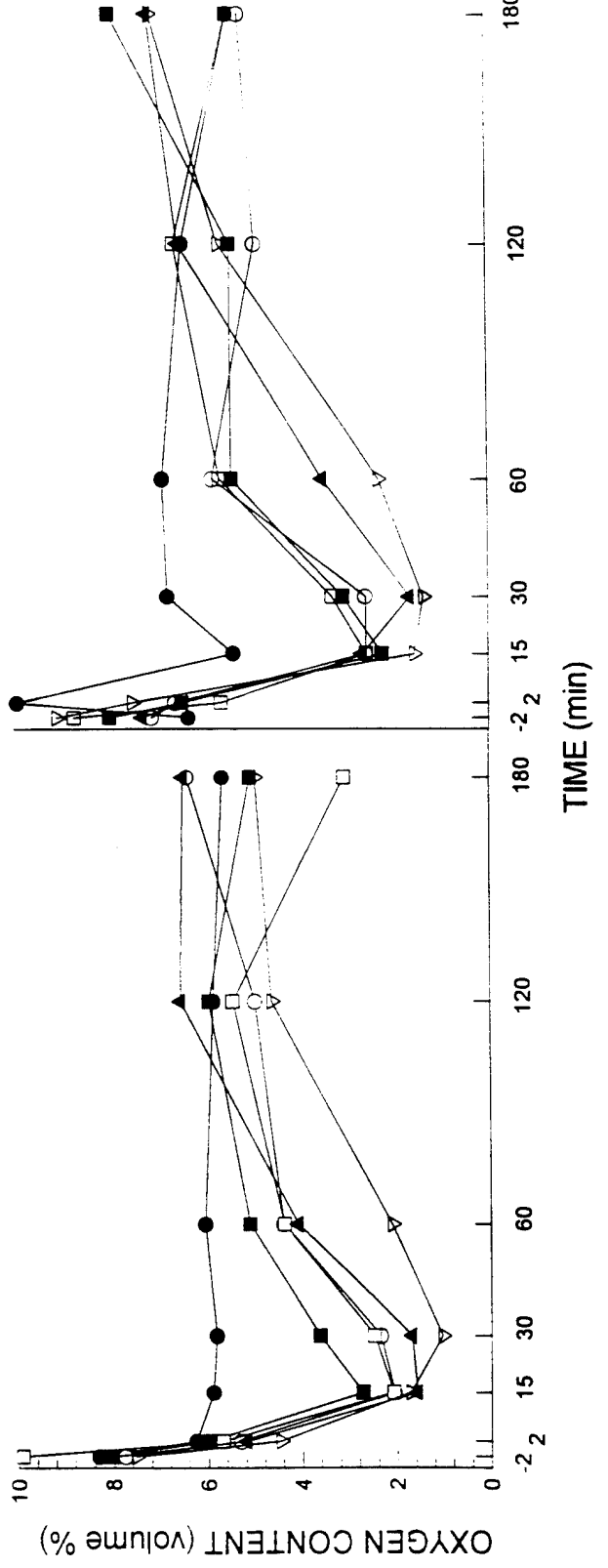
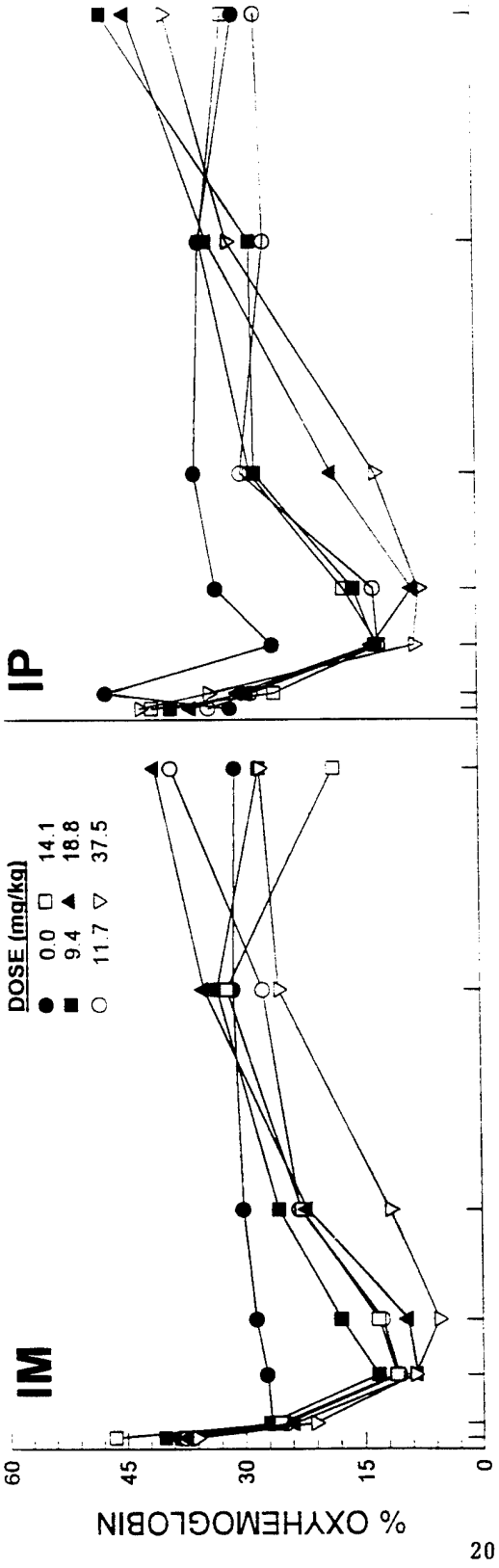
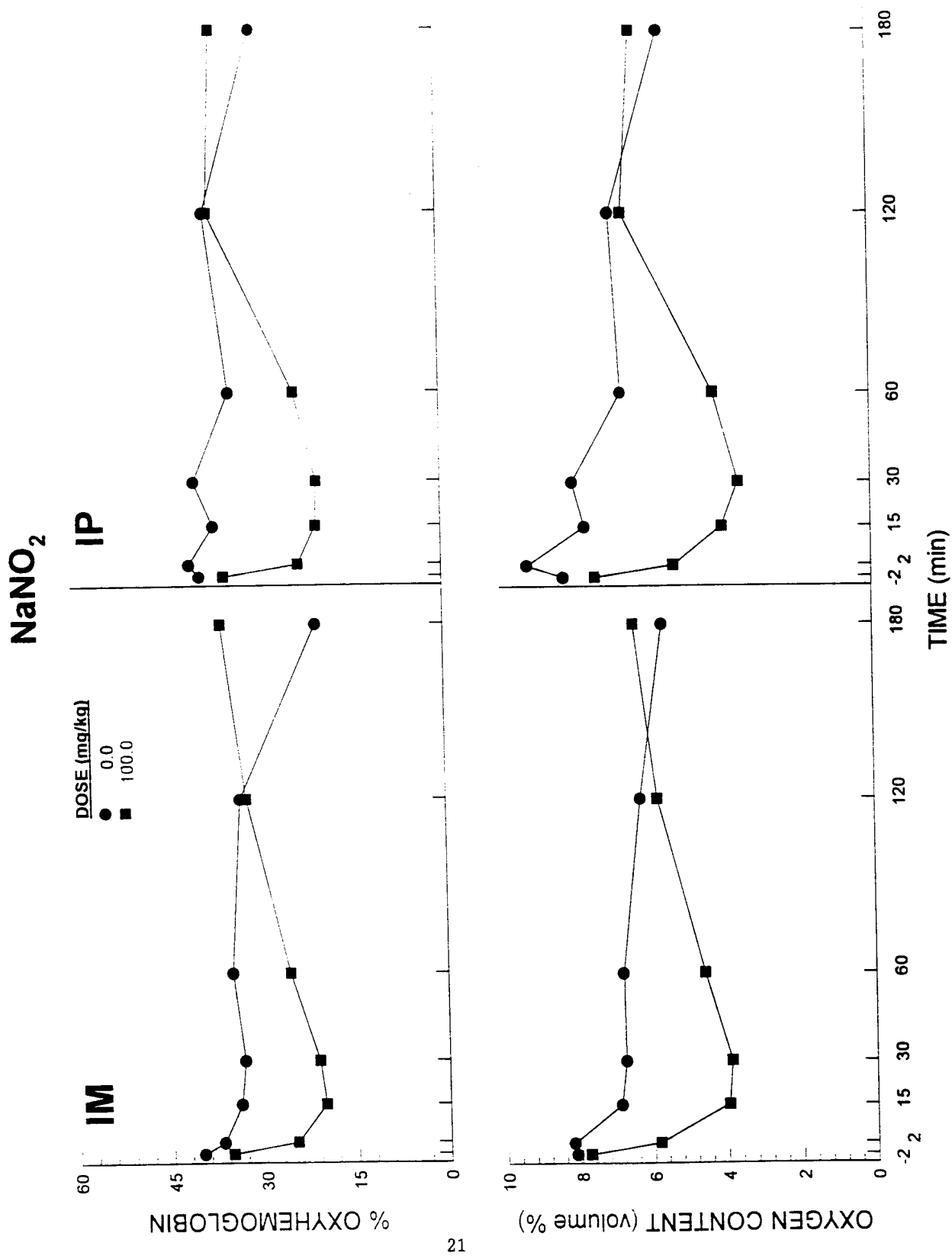
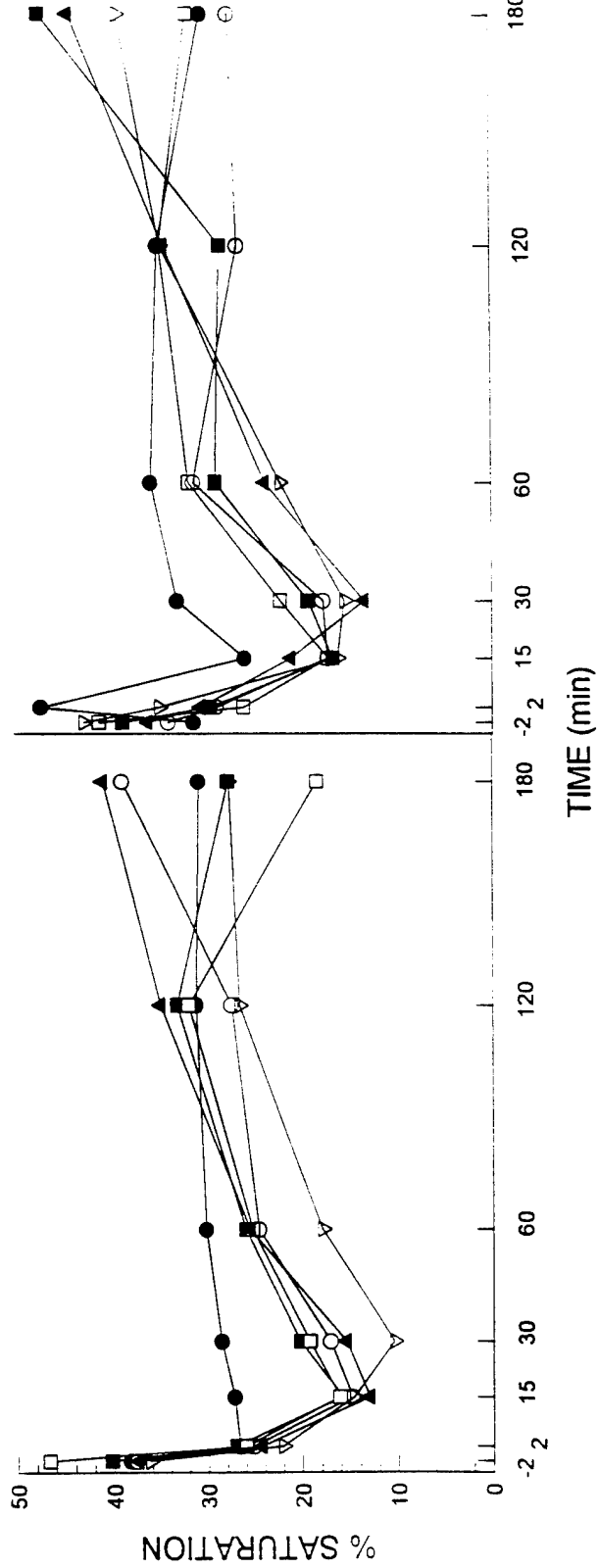
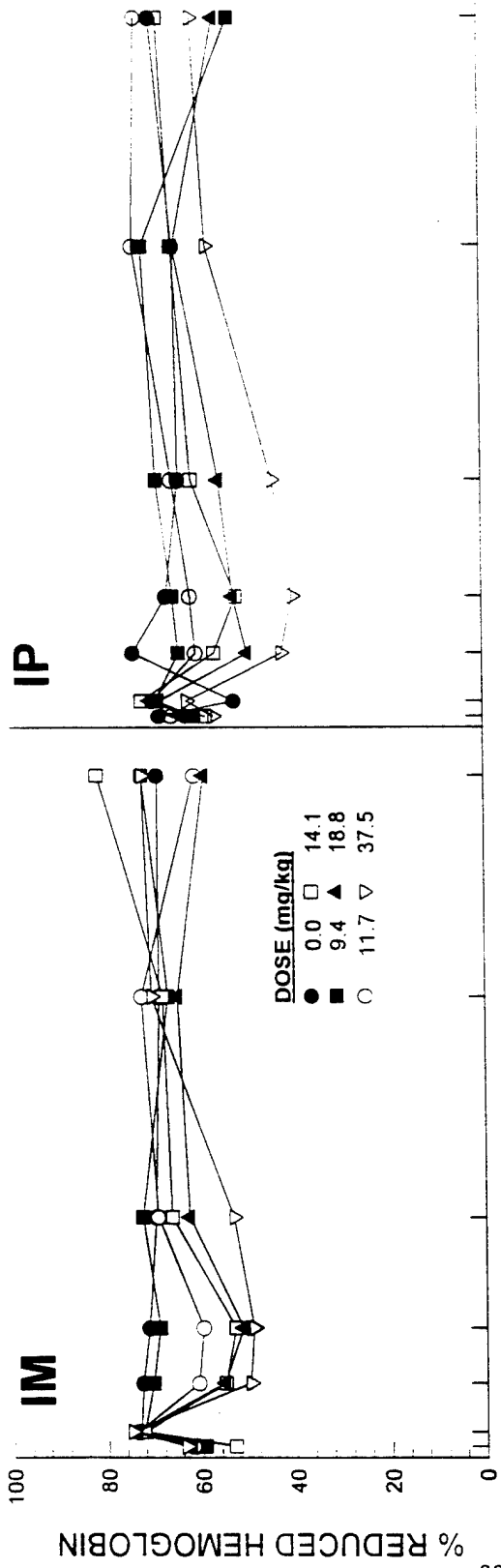

Fig 1



# PAPP



Fig

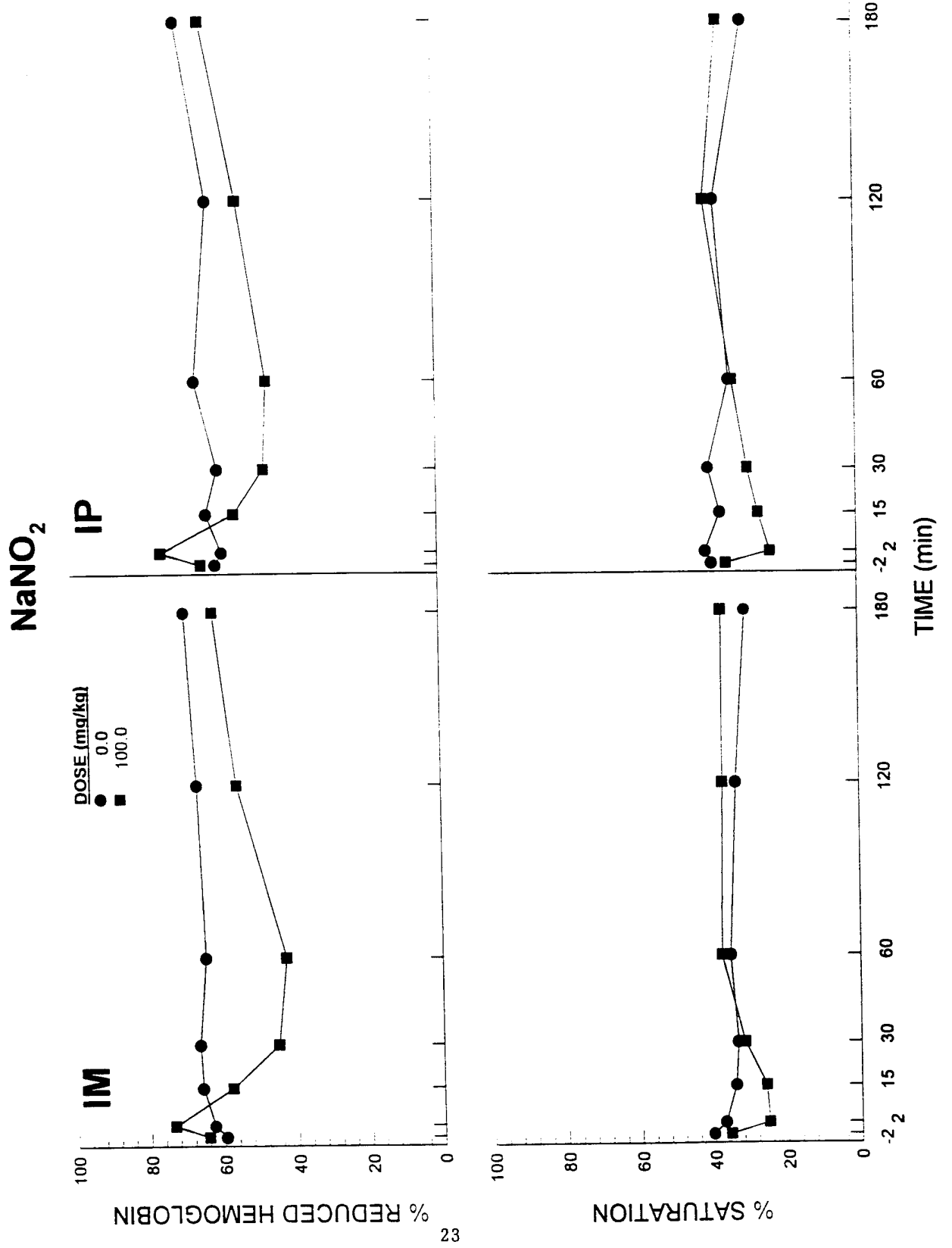

# PAHP

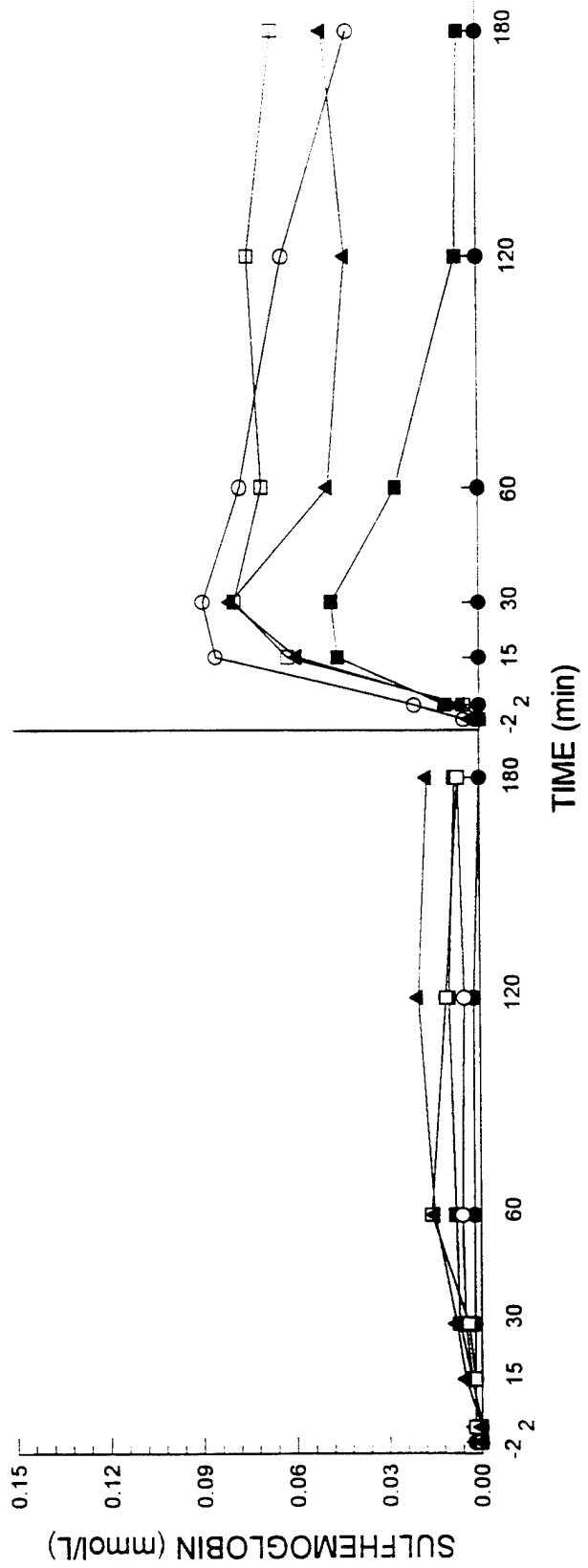
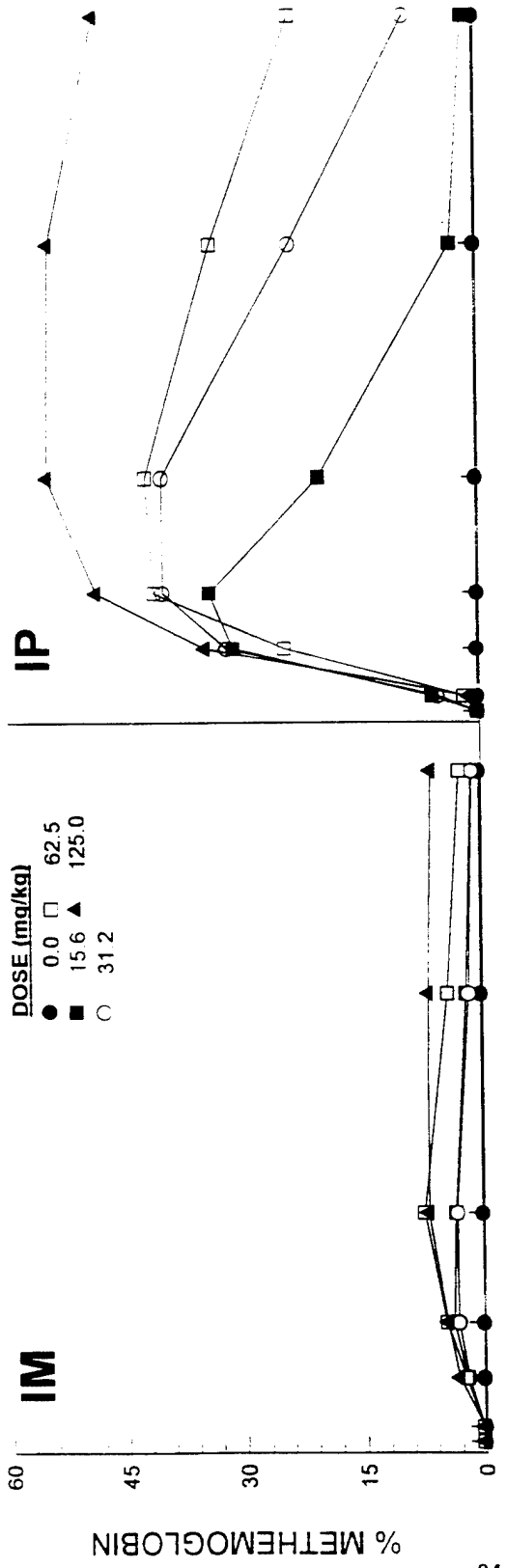

# PAOP

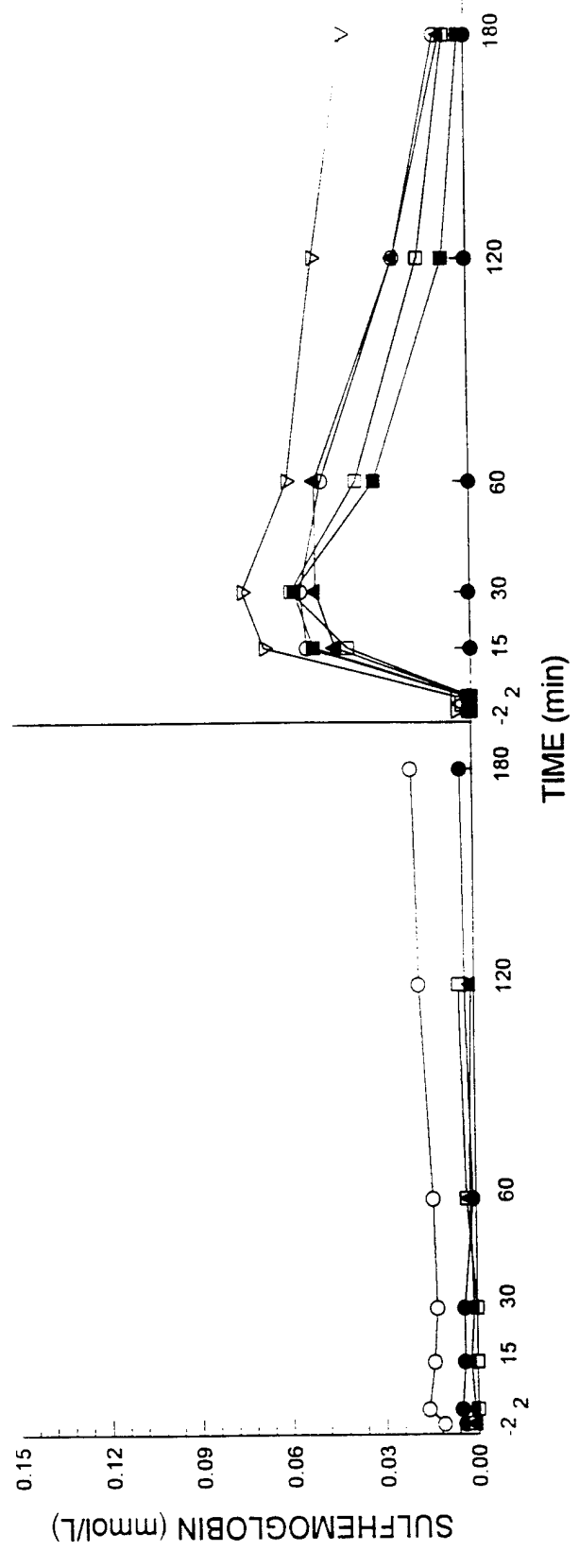
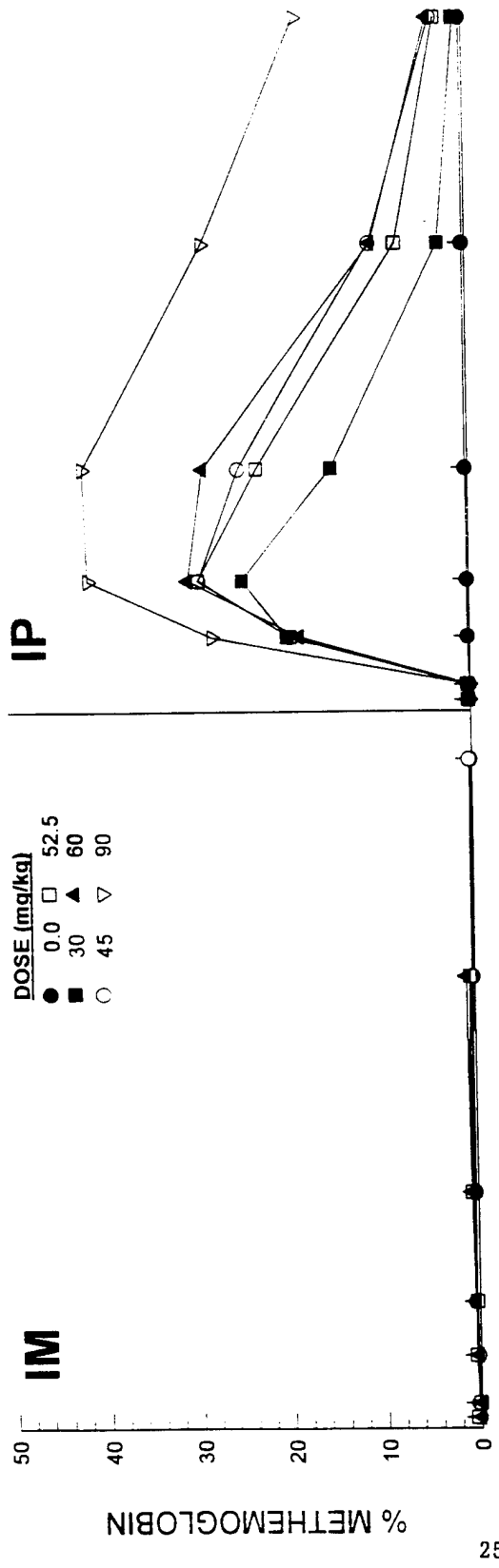
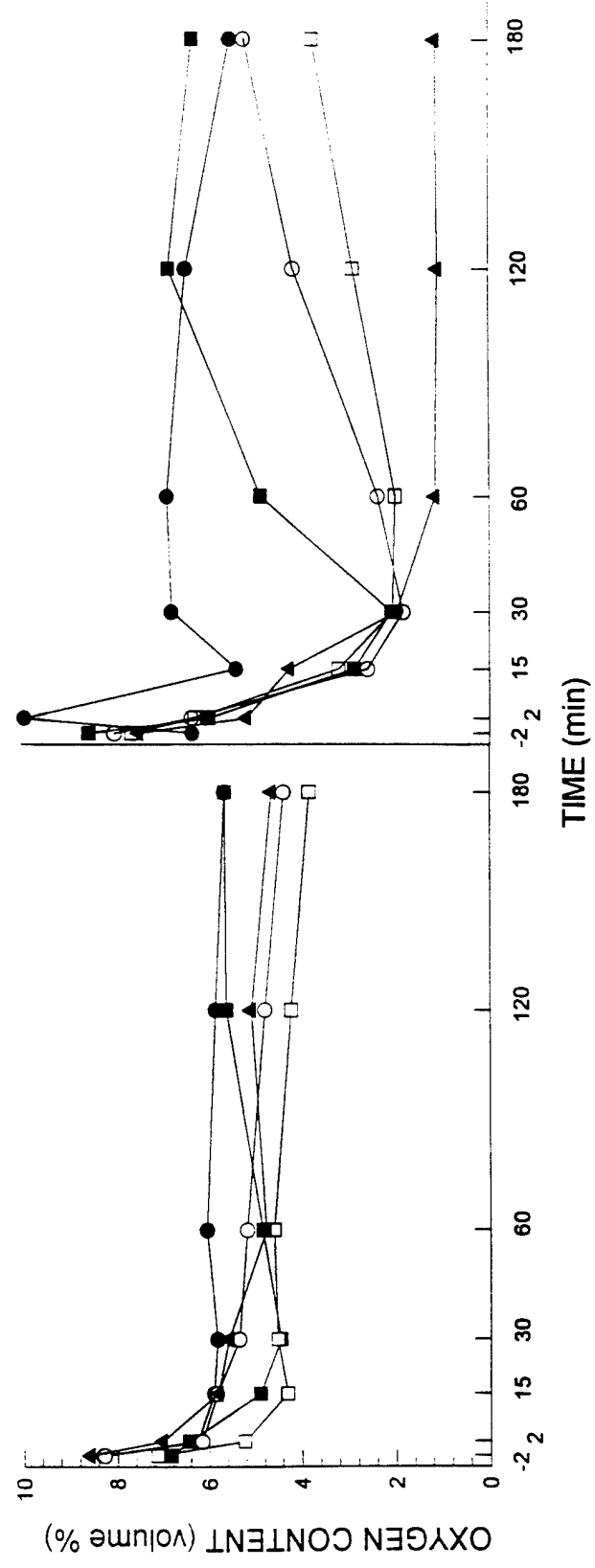
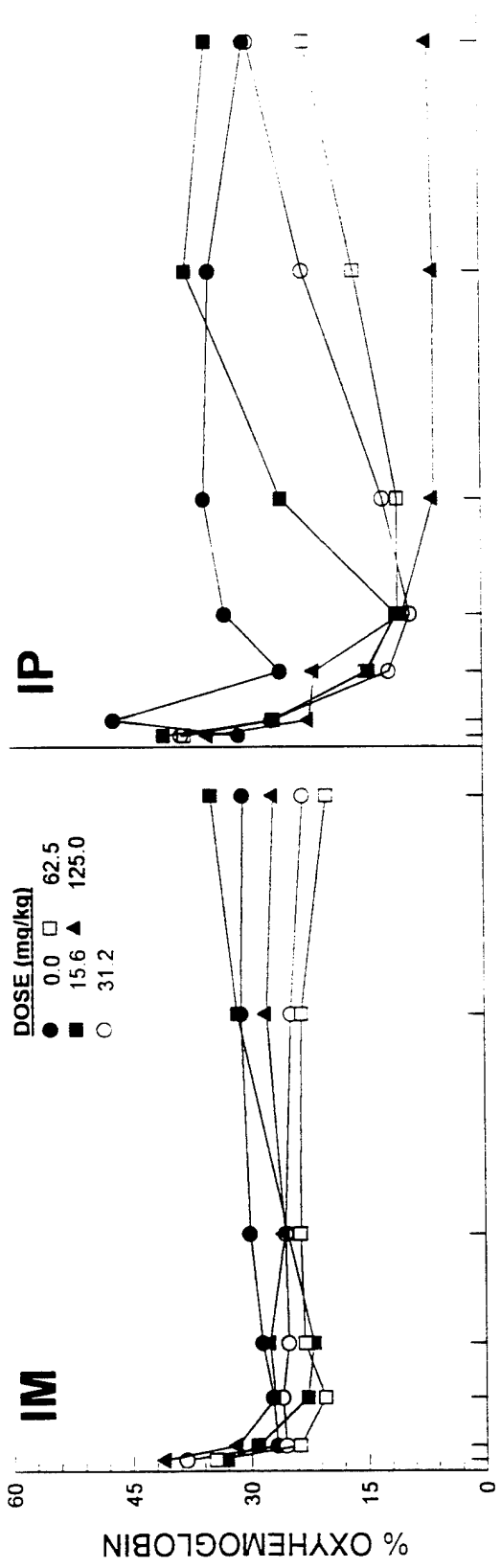
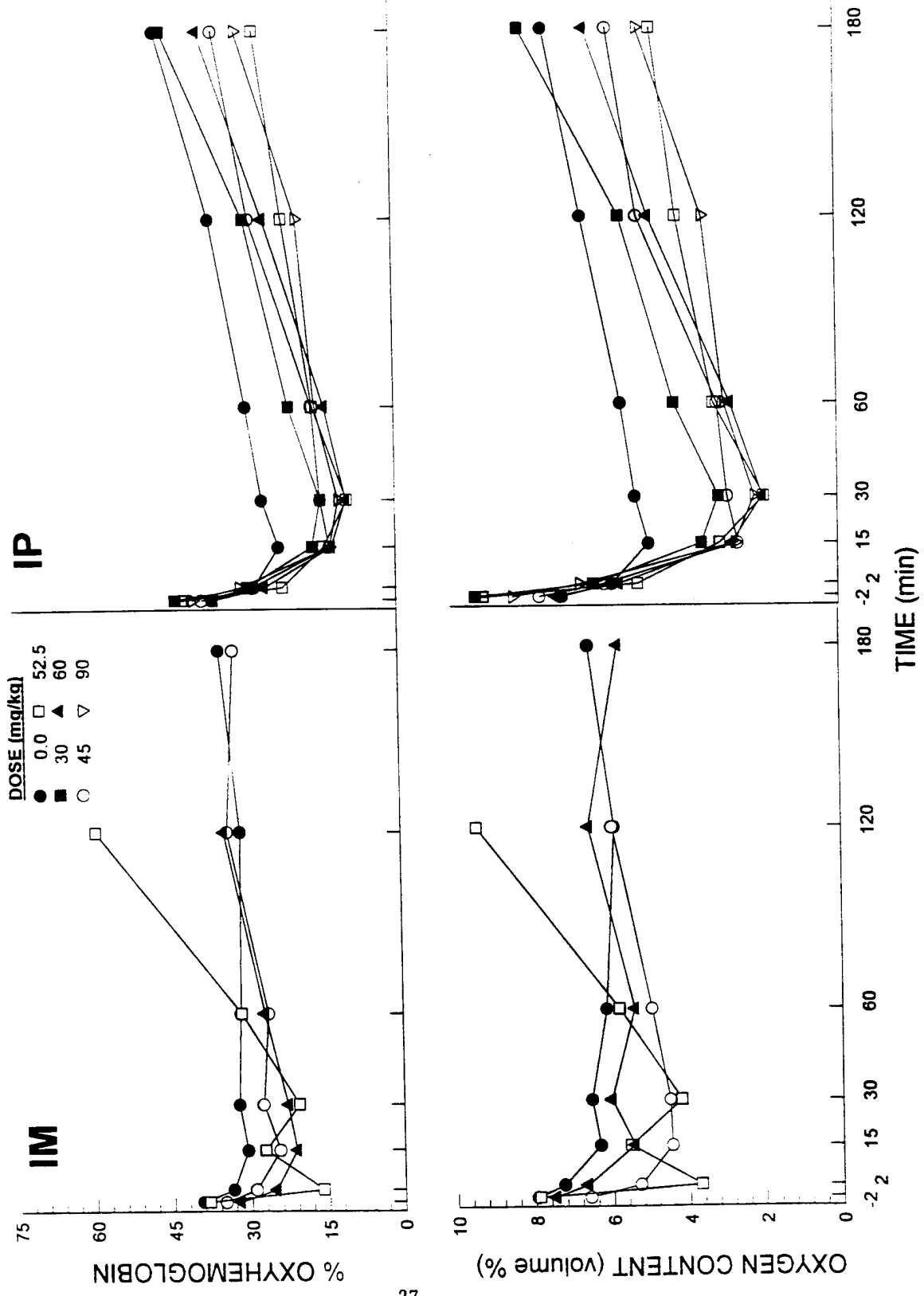

Fig 1

# PAHP



# PAOP



# PAHP

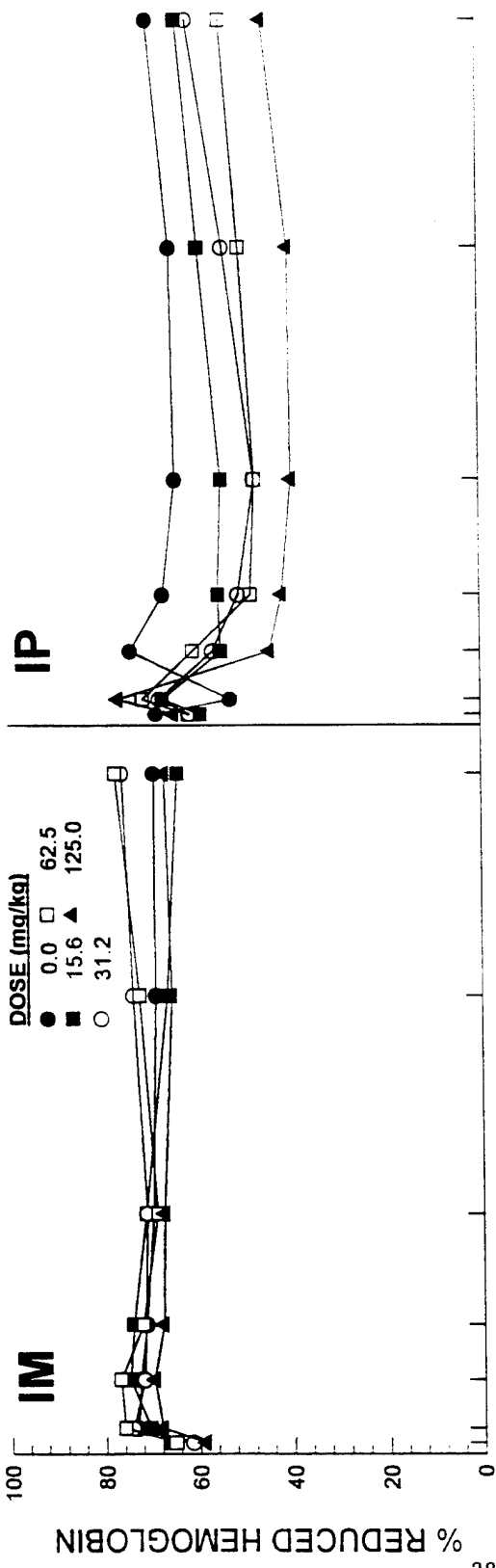

28

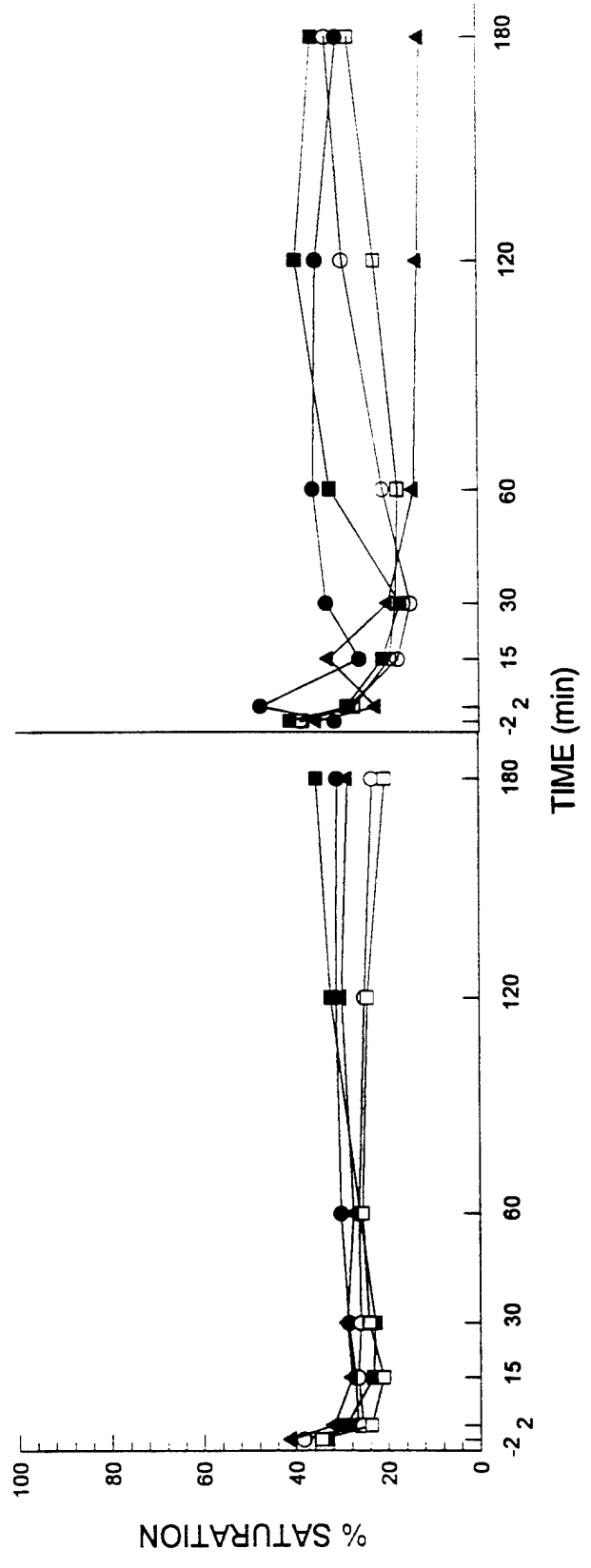

12

# PAOP

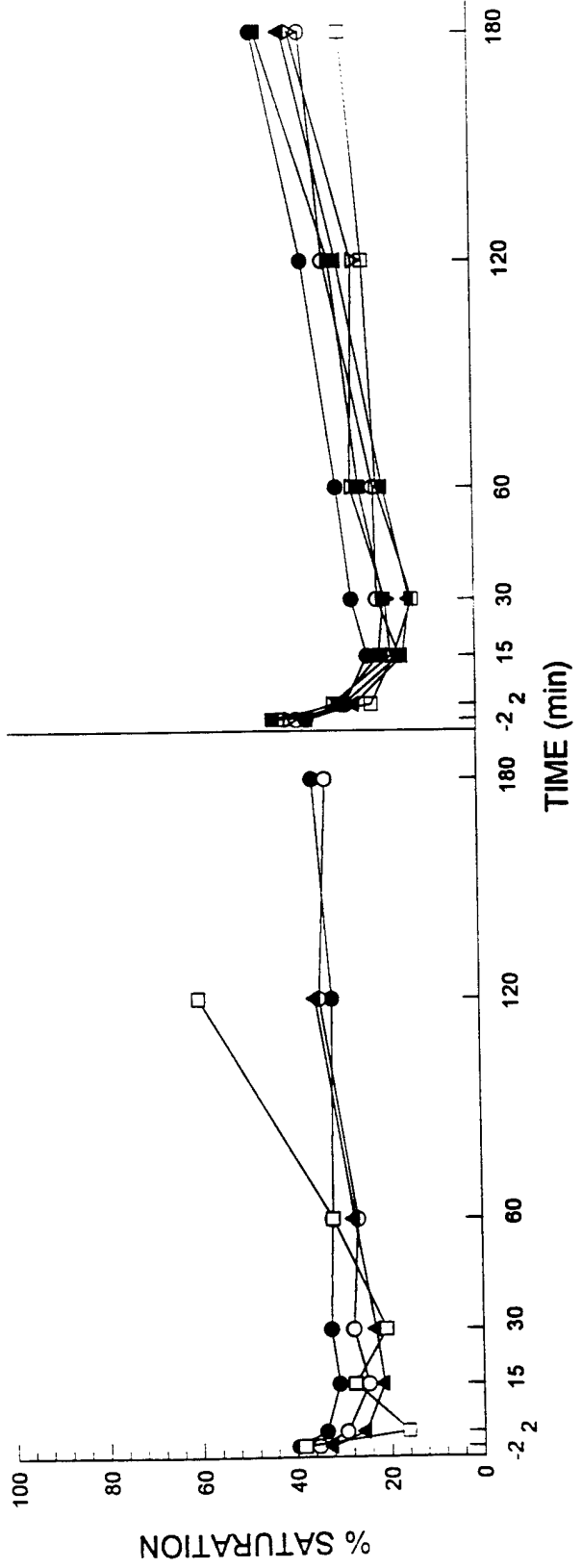
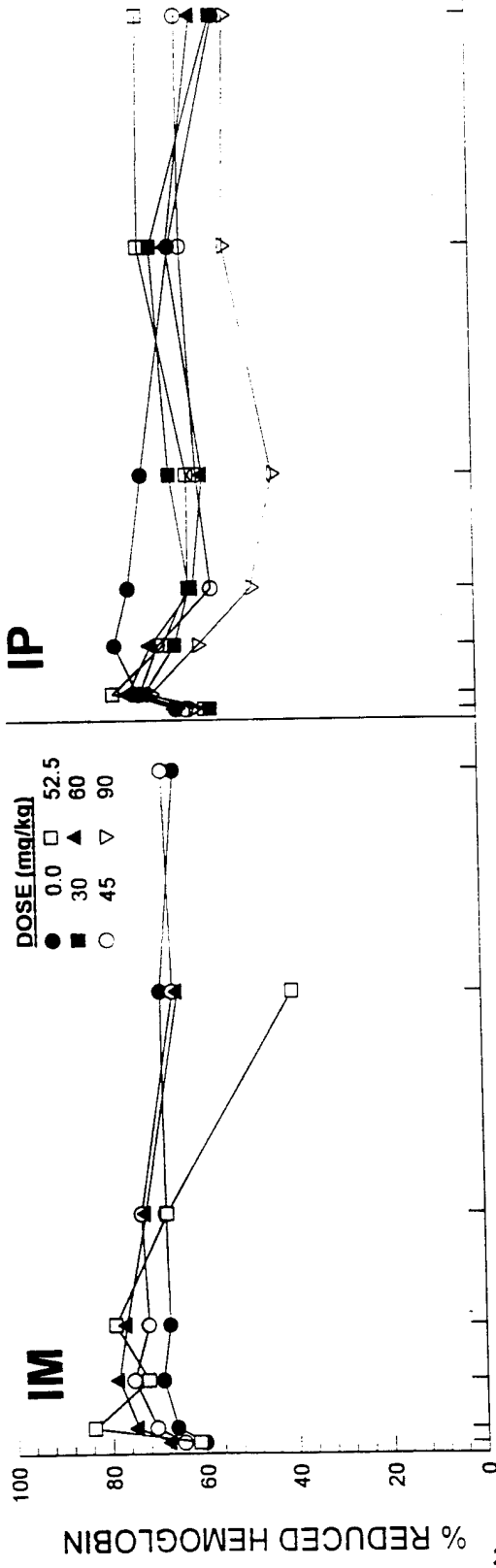

Fig 14

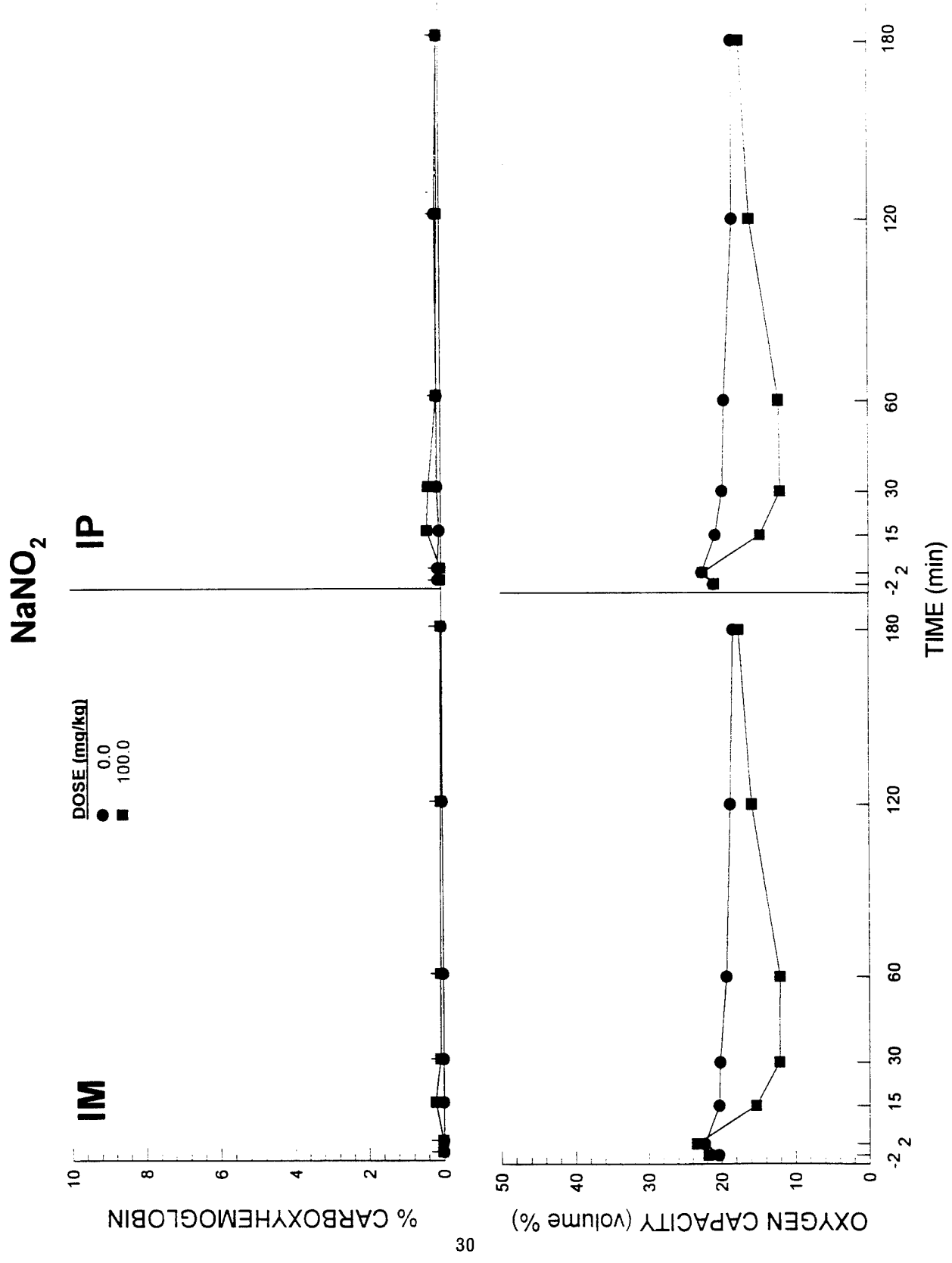

Fig 15

# PAOP

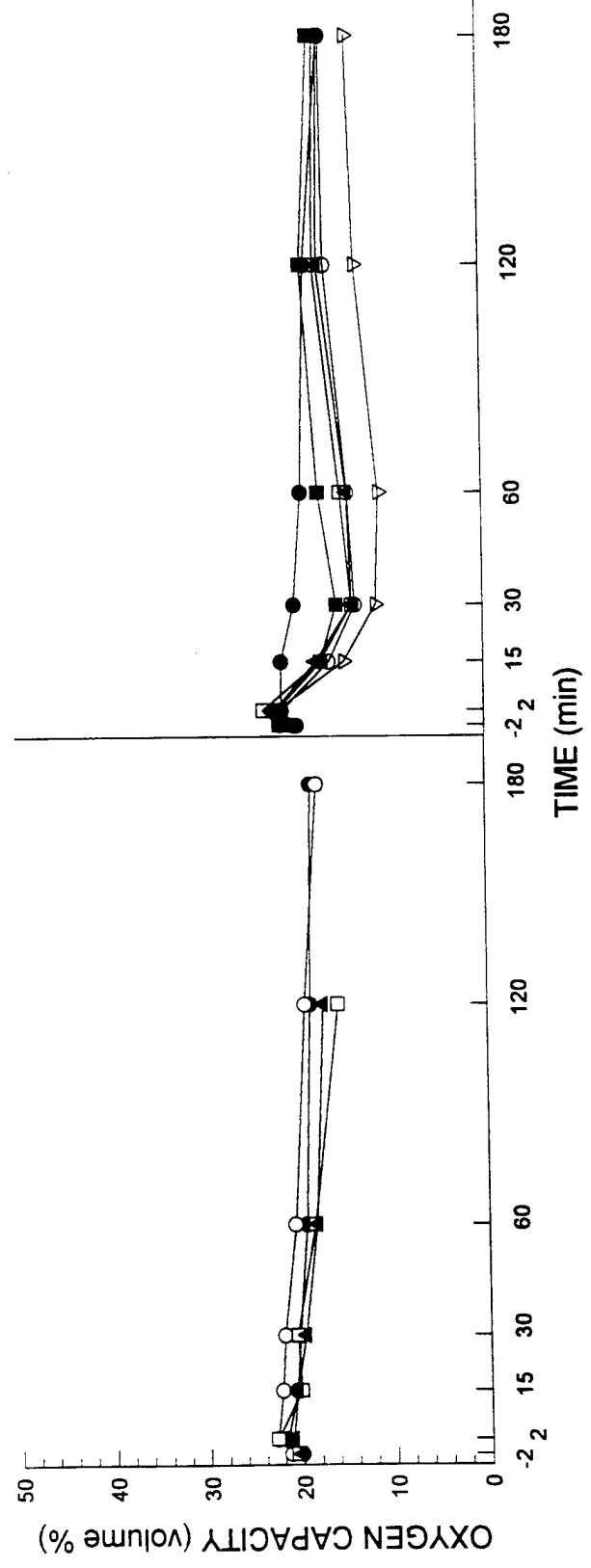
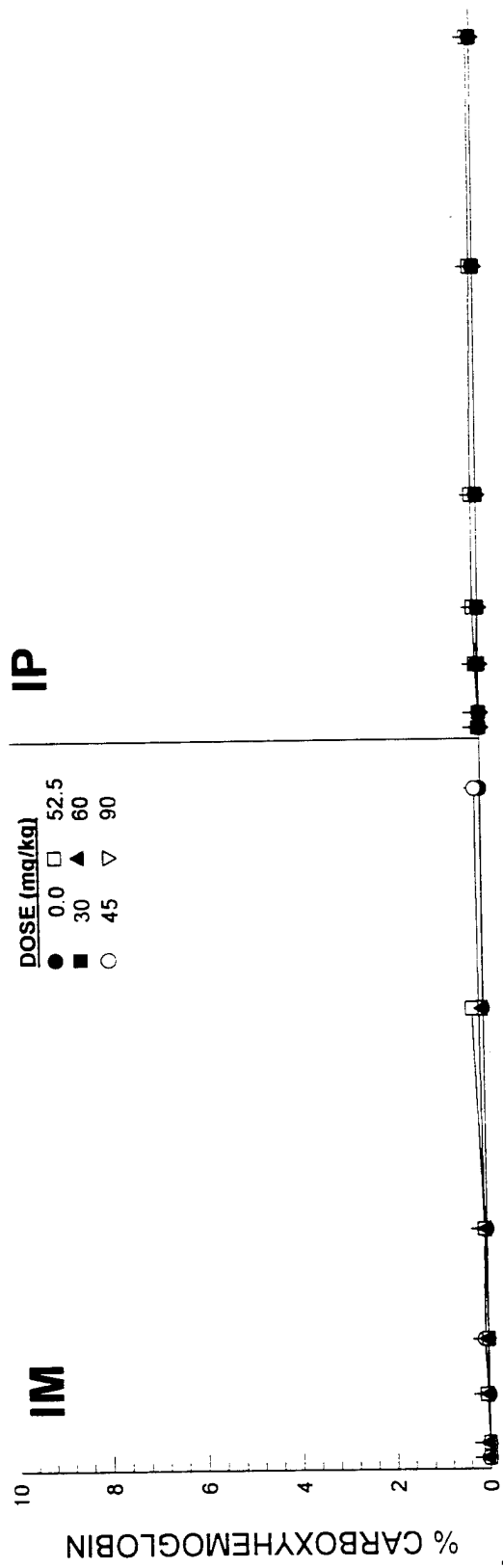

Fig 16

# PAPP

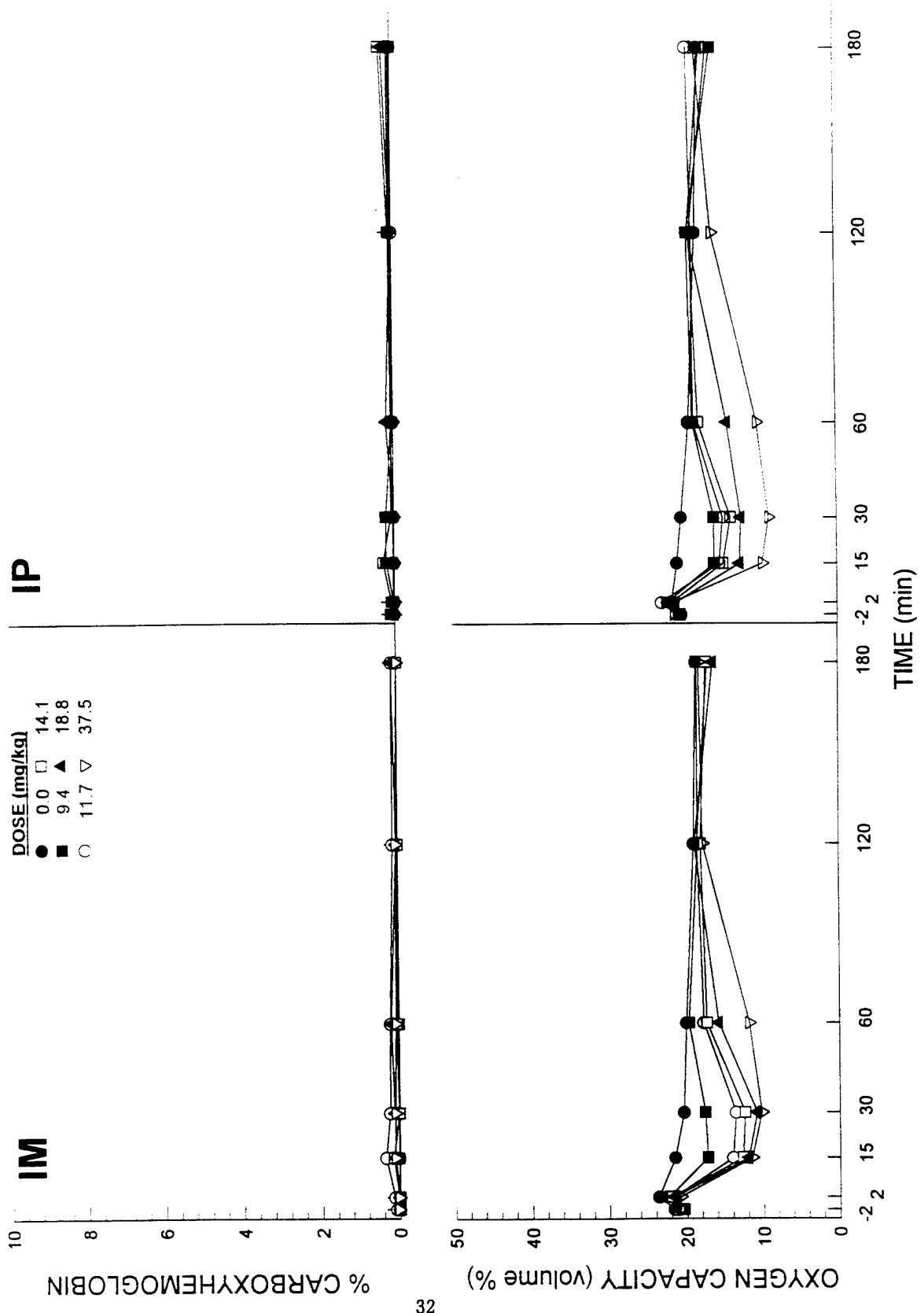
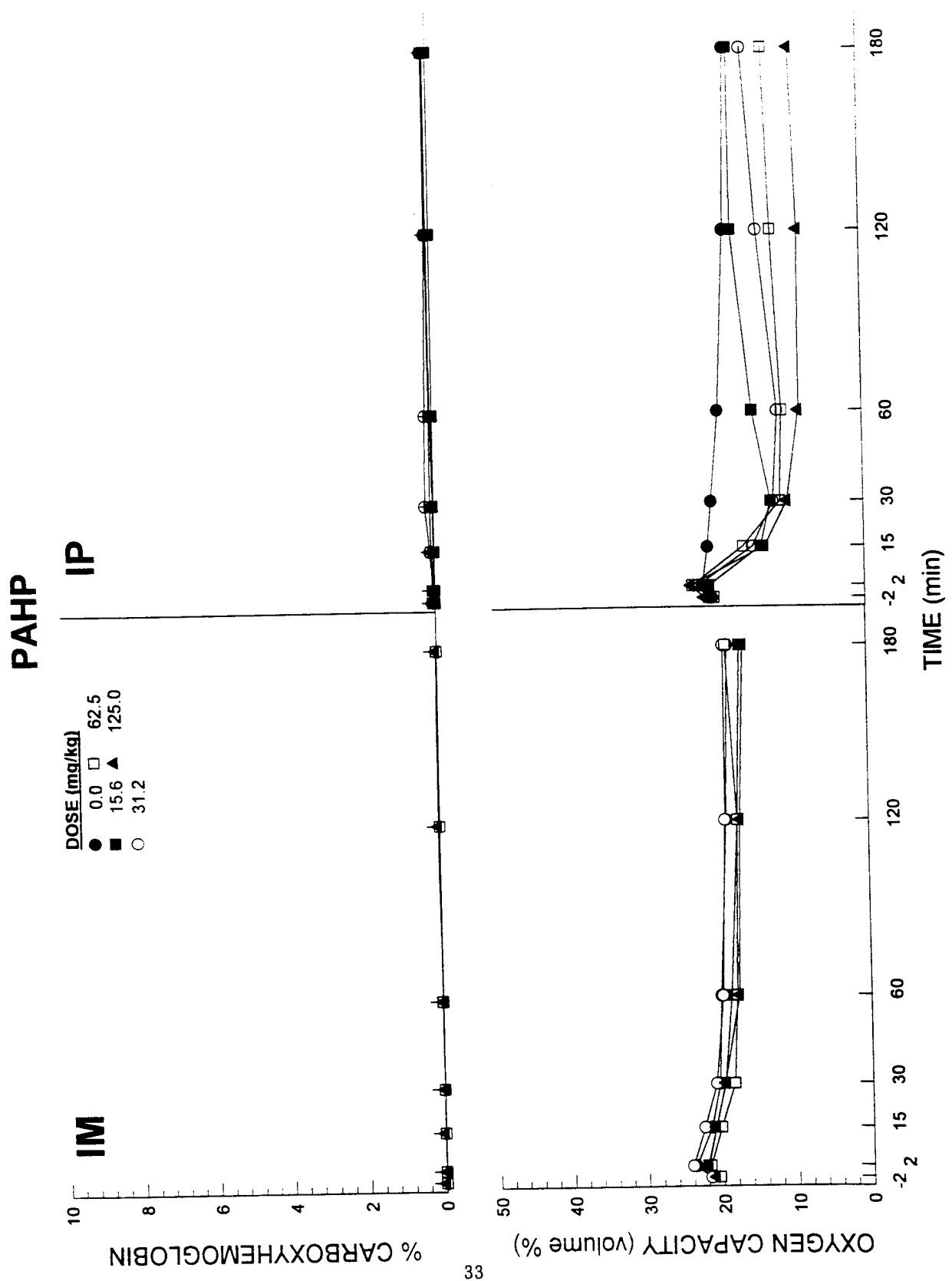

Fig 17



## REFERENCES

- Abbanat, R.A. and Smith, R.P.: The influence of methemoglobinemia on the lethality of some toxic anions. I. Azide. *Toxicol. Appl. Pharmacol.*, 6: 576-583, 1964.
- Agency for Toxic Substances and Disease Registry (ATSDR): Cyanide Toxicity. *Am. Fam. Physician*, 48: 107-114, 1993.
- Baskin, S. I. and Fricke, R.: The pharmacology of *p*-aminopropiophenone in the detoxification of cyanide. *Cardiovasc. Drug Rev.*, 10: 358-375, 1992.
- Baskin, S. I., Horowitz, A. M. and Nealley, E. W.: The antidotal action of sodium nitrite and sodium thiosulfate against cyanide poisoning. *J. Clin. Pharmacol.*, 32: 368-375, 1992.
- Bastian, G. and Mercker, H.: On the effectiveness of amyl nitrite inhalation in cyanide treatment. *Naunyn-Schmied. Arch. Exper. Pathol. Pharmacol.*, 237: 285-295, 1959.
- Beutler, E. and Mikus, B. J.: The effect of sodium nitrite and para-aminopropiophenone administration on blood methemoglobin levels and red blood cell survival. *Blood*, 18: 455-467, 1961.
- Beutler, E.: Drug-induced hemolytic anemia. *Pharmacol. Rev.*, 21: 73-103, 1969.
- Beutler, E.: Methemoglobinemia and sulfhemoglobinemia. *In Hematology*, 2nd edition, ed. by W. J. Williams, E. Beutler, A. J. Erslev and R. W. Rundles, pp. 491-494, McGraw-Hill Book Co., New York, 1977.
- Bodansky, O. and Guttman, H.: Treatment of methemoglobinemia. *J. Pharmacol. Exp. Ther.*, 90: 46-56, 1947.
- Bodansky, O. and Hendley, C. D.: Effect of methemoglobinemia on the visual threshold at sea level, at high altitudes, and after exercise. *J. Clin. Invest.*, 25: 717-722, 1946.
- Bright, J. E.: A prophylaxis for cyanide poisoning. *In Clinical and Experimental Toxicology of Cyanides*, ed. by B. Ballantyne and T. C. Marrs, pp. 359-382, Wright, Bristol, UK, 1987.
- Bright, J. E. and Marrs, T. C.: The induction of methemoglobin by *p*-aminophenones. *Toxicol. Lett.*, 18: 157-161, 1983.
- Canfield, C. J., Heiffer, M. H. and Korte, D. W.: Method and composition for inducing low levels of methemoglobinemia for protection against cyanide poisoning. Technical Report, DTIC No. AD-D012 588, Department of the Army, 1987.

- Chen, K. K. and Rose, C. L.: Nitrite and thiosulfate therapy in cyanide poisoning. *J.A.M.A.*, 149: 113-119, 1952.
- Chen, K. K., Rose, C. L. and Clowes, G. H. A.: Amyl nitrite and cyanide poisoning. *J.A.M.A.*, 100: 1920-1922, 1933.
- Chen, K. K., Rose, C. L. and Clowes, G. H. A.: Comparative values of several antidotes in cyanide poisoning. *Am. J. Med. Sci.*, 188: 767-771, 1934.
- Chen, K. K., Rose, C. L. and Clowes, G. H. A.: Cyanide poisoning and its treatment. *J. Am. Pharmaceut. Assn.*, 34: 625-630, 1935.
- Combemale, M.: Methylene blue's methemoglobin producing effect. *Comp. Rend. de Biol.*, 43: 300-302, 1891.
- Compton, J. A. F.: *Military Chemical and Biological Agents*, The Telford Press, Caldwell, NJ, 1987.
- D'Mello, G. D.: Neuropathological and behavioural sequelae of acute cyanide toxicosis in animal species. *In Clinical and Experimental Toxicology of Cyanides*, ed. by B. Ballantyne and T. C. Marrs, pp. 156-183, Wright, Bristol, UK, 1987.
- Frankenberg, L. and Sorbo, B.: Amyl nitrite as an antidote for the treatment of cyanide poisoning. A critical evaluation. *Forsvarsmedicin*, 11: 226-229, 1975.
- Frankenberg, L.: *Studies on cyanide detoxification*. Doctoral Dissertation, University of Uppsala, 1982.
- Geiger, J. C.: Cyanide poisoning in San Francisco. *J.A.M.A.*, 99: 1944-1945, 1932.
- Haldane, J. H., Makgill, R. H. and Mavrogordato, A. E.: The action of poisons of nitrites and other physiologically related substances. *J. Physiol.*, 21: 160-189, 1897.
- Hall, A. H., Kulig, K. W. and Rumack, B. H.: Drug- and chemical-induced methemoglobinemia. Clinical features and management. *Med. Toxicol.*, 1: 253-260, 1986.
- Hanzlik, P. J. and Richardson, A. P.: Cyanide antidotes. *J.A.M.A.*, 102: 1740-1745, 1934.
- Holmes, R. K. and Way, J. L.: Mechanism of cyanide antagonism by sodium nitrite. *The Pharmacologist*, 24: 182, 1982.
- Hug, E.: Cyanide poisoning: methemoglobinizing substances as antidotes to cyanide poisoning. *Comp. Rend. Soc. de Soc. Biol.*, 112: 511-513, 1933a.

- Hug, E.: New developments in the treatment of cyanide poisoning. The use of sodium nitrite and how it exerts its action. *La Prensa Med. Argen.*, 7: 371-375, 1933b.
- Jandorf, B. J. and Bodansky, O.: Therapeutic and prophylactic effect of methemoglobinemia in inhalation poisoning by hydrogen cyanide and cyanogen chloride. *J. Industr. Hygiene Toxicol.*, 28: 125-132, 1946.
- Kiese, M., Lorcher, W., Weger, N. and Zierer, A.: Comparative studies on the effects of toluidine blue and methylene blue on the reduction of ferrihaemoglobin in man and dog. *Eur. J. clin. Pharmacol.* 4: 115-118, 1972.
- Kiese, M. and Weger, N.: Formation of ferrihaemoglobin with aminophenols in the human for the treatment of cyanide poisoning. *Eur. J. Pharmacol.*, 7: 97-105, 1969.
- Marrs, T. C., Bright, J. E. and Inns, R. H.: Methaemoglobin production and reduction by methylene blue and interaction of methylene blue with sodium nitrite *in vivo*. *Human Toxicol.*, 8: 359-364, 1989.
- Martin, D. G., Watson, C. E., Gold, M. B., Woodard, C. L. and Baskin, S. I.: Topical anesthetic-induced methemoglobinemia and sulfhemoglobinemia in macaques: A comparison of benzocaine and lidocaine. *Journal of Applied Toxicology*, in press.
- McKay, C. A. and Vogel, V. Chemical and biological weapons. *Emerg. Care Quart.*, 7: 30-37, 1992.
- Mladoveanu, C. and Gheorghiu, P.: Sodium nitrite as antidote for experimental potassium cyanide poisoning. *Comp. Rend. de Soc. Biol.*, 102: 164-166, 1929.
- Nadler, J. E., Green, H. and Rosenbaum, A.: Intravenous injection of methylene blue in man with reference to its toxic symptoms and effect on the electrocardiogram. *Am. J. Med. Sci.*, 188: 15-21, 1934.
- Nomura, A.: Studies on sulfhemoglobin formation by various drugs. *Nippon Yakur. Zass.*, 73: 423-435, 1977.
- Paulet, G.: On the value of amyl nitrite in the treatment of hydrocyanic acid poisoning. *Comp. Rend. de Soc. Biol.*, 148: 1009-1014, 1954.
- Paulet, G., Aubertin, X., Laurens, L. and Bourrelier, J.: On the methemoglobinizing effect of paraaminopropiophenone in man - with an experimental compliment in the dog. *Arch. int. Pharmacodyn.*, 142: 35-51, 1963.
- Pedigo, L. G.: Antagonism between amyl nitrite and prussic acid. *Trans. Med. Soc. Virg.*, 19:

124-131, 1888.

- Rockwood, G. A., Baskin, S. I., Murrow, M. L., Preville, J. A., Nealley, E. W., Lee, R. B. and Romano, J. A.: The effects of PAPP, PAOP and PAHP on selected blood analytes. *The FASEB Journal*, 8: A673, 1994.
- Rockwood, G. A., Romano, J. A., and Baskin, S. I. The effects of p-aminopropiophenone (PAPP) and p-aminooctanoylphenone (PAOP) against sodium cyanide (CN) challenge and on righting and motor activity in mice. *The Toxicologist*, 12: 271, 1992.
- Scharf, B. A., Fricke, R. F. and Baskin, S. I.: Comparison of methemoglobin formers in protection against the toxic effects of cyanide. *Gen. Pharmacol.*, 23: 19-25, 1992.
- Smith, R. P.: Toxic responses of the blood. *In Casarett and Doull's Toxicology*, 4th edition, ed. by M. O. Amdur, J. Doull and C. D. Klaassen, pp. 257-281, Pergamon Press, New York, 1991.
- Smith, R. P., Alkaitis, A. A. and Shafer, P. R.: Chemically induced methemoglobinemias in the mouse. *Biochem. Pharmacol.*, 317-328, 1967.
- Tepperman, J., Bodansky, O. and Jandorf, B. J.: The effect of para-aminopropiophenone-induced methemoglobinemia on oxygenation of working muscle in human subjects. *Am. J. Physiol.*, 146: 702-709, 1946.
- United States Senate. Committee on Governmental Affairs. Hearings on Global Spread of Chemical and Biological Weapons: Assessing Challenges and Responses. Washington: GPO, 1989.
- van Heijst, A. N. P., Douze, J. M. C., Van Kesteren, R. G., Bergen, J. E. A. M. and Van Dijk, A.: Therapeutic problems in cyanide poisoning. *Clin. Toxicol.*, 25: 383-398, 1987.
- van Heijst, A. N. P. and Meredith, T. J.: Antidotes for cyanide poisoning. *In Basic Science in Toxicology*, ed. by G. N. Volans, J. Sims, F. M. Sullivan and P. Turner, pp. 558-566, Taylor & Francis, London, 1990.
- Vandenbelt, J. M., Pfeiffer, C., Kaiser, M. and Sibert, M.: Methemoglobinemia after administration of p-aminoacetophenone and p-aminopropiophenone. *J. Pharmacol. Exp. Ther.*, 80: 31-38, 1944.
- Way, J. L. Cyanide intoxication and its mechanism of antagonism. *Ann. Rev. Pharmacol. Toxicol.*, 24: 451-481, 1984.

Wendel, W. B.: The control of methemoglobinemia with methylene blue. *J. Clin. Invest.*, 18: 179-185, 1939.

Wendel, W. B.: The mechanism of the action of methylene blue and sodium nitrite in cyanide poisoning. *J. Biol. Chem.*, 100: c-ci, 1933.

Distribution List

Addresses	Copies	Addresses	Copies
DEFENSE TECHNICAL INFORMATION CENTER ATTN DTIC OCP 8725 JOHN J KINGMAN RD STE 0944 FT BELVOIR VA 22060-6218	2	DIRECTOR ARMED FORCES MEDICAL INTELLIGENCE CENTER FORT DETRICK MD 21702-5004	1
COMMANDER US ARMY MEDICAL RESEARCH AND MATERIEL COMMAND FORT DETRICK MD 21702-5012	2	COMMANDER US ARMY INSTITUTE OF DENTAL RESEARCH BUILDING 40 WASHINGTON DC 20307-5300	1
HQDA DASG HCD WASHINGTON DC 20310	1	COMMANDER US ARMY INSTITUTE OF SURGICAL RESEARCH BUILDING 2653 FORT SAM HOUSTON TX 78234-6200	1
DIRECTOR WALTER REED ARMY INSTITUTE OF RESEARCH BUILDING 40 WASHINGTON DC 20307-5100	1	COMMANDANT ACADEMY OF HEALTH SCIENCES US ARMY ATTN HSHA CDC FORT SAM HOUSTON TX 78234-6100	1
COMMANDER US ARMY AEROMEDICAL RESEARCH LABORATORY ATTN SCIENTIFIC INFORMATION CENTER PO BOX 577 FORT RUCKER AL 36362-5000	1	COMMANDANT ACADEMY OF HEALTH SCIENCES US ARMY ATTN HSHA CDM FORT SAM HOUSTON TX 78234-6100	1
COMMANDER US ARMY MEDICAL RESEARCH INSTITUTE OF INFECTIOUS DISEASES BUILDING 1425 FORT DETRICK MD 21702-5011	1	Dr. JOSEPH OSTERMAN DIRECTOR ENVIRONMENTAL AND LIFE SCIENCES OFFICE OF THE DEPUTY DIRECTOR FOR RESEARCH AND ENGINEERING ROOM 3D129 WASHINGTON DC 20301-2300	1
COMMANDER US ARMY RESEARCH INSTITUTE OF ENVIRONMENTAL MEDICINE BUILDING 42 NATICK MA 01760-5007	1	COMMANDER US ARMY TRAINING AND DOCTRINE COMMAND ATTN ATMD FORT MONROE VA 23651	1
COMMANDANT US ARMY CHEMICAL SCHOOL ATTN ATZN CM C FORT MCCLELLAN AL 36205	1		

COMMANDER US ARMY NUCLEAR AND CHEMICAL AGENCY 7500 BACKLICK ROAD BUILDING 2073 SPRINGFIELD VA 22150-3198	1	AFOSR/NL BUILDING RM A217 BOLLING AFB DC 20332	1
EXECUTIVE OFFICER NAVAL MEDICAL RESEARCH INSTITUTE NAVAL MEDICINE COMMAND NATIONAL CAPITAL REGION BETHESDA MD 20814	1	COMMANDER US ARMY CHEMICAL BIOLOGICAL DEFENSE AGENCY ATTN AMSCB CI ABERDEEN PROVING GROUND MD 21010-5423	1
USAF ARMSTRONG LABORATORY/CFTO SUSTAINED OPERATIONS BRANCH BROOKS AFB TX 78235-5000	1	LTC RICHARD R. STOTTS BATTELLE MEMORIAL INSTITUTE JM 3 505 KING AVENUE COL UMBUS OH 43201-2695	1
DEPARTMENT OF HEALTH AND HUMAN SERVICES NATIONAL INSTITUTES OF HEALTH THE NATIONAL LIBRARY OF MEDICINE SERIAL RECORDS SECTION 8600 ROCKVILLE PIKE BETHESDA MD 20894	1	COMMANDER US ARMY MEDICAL RESEARCH INSTITUTE OF CHEMICAL DEFENSE ATTN MCMR UV ZA MCMR UV ZB MCMR UV ZS MCMR UV RC (5 copies) MCMR UV R (11 copies) MCMR UV AI W MCMR UV D MCMR UV P MCMR UV V MCMR UV Y ABERDEEN PROVING GROUND MD 21010-5425	24
STEMSON LIBRARY ACADEMY OF HEALTH SCIENCES BUILDING 2840 RM 106 FORT SAM HOUSTON TX 78234-6100	1		
US ARMY RESEARCH OFFICE ATTN CHEMICAL AND BIOLOGICAL SCIENCES DIVISION PO BOX 12211 RESEARCH TRIANGLE PARK NC 27709-2211	1		