

AFCTN Test Report 94-041

AFCTB-ID
93-070



Technical Publication Transfer

Using:



IBM SID, Boulder's Data



MIL-M-28001A (SGML)
MIL-R-28002A (Raster)



Quick Short Test Report

19960822 051

12 July 1993



Prepared for:
Electronic Systems Center
Det 2 HQ ESC/AV-2
4027 Colonel Glenn Hwy, Suite 300
Dayton, Ohio 45431-1672

DTIC QUALITY INSPECTED 3

DISTRIBUTION STATEMENT A

Approved for public release;
Distribution Unlimited.

AFCTN Test Report
94-041

AFCTB-ID
93-070

Technical Publication Transfer

Using:

IBM SID Boulder's Data

MIL-M-28001A (SGML)

MIL-R-28002A (Raster)

Quick Short Test Report

12 July 1993

Prepared By

Air Force CALS Test Bed
Wright-Patterson AFB, OH 45433

AFCTB Contact

Gary Lammers
(513) 427-2295

AFCTN Contact

Mel Lammers
(513) 427-2295

DTIC QUALITY INSPECTED 3

DISCLAIMER

This document was prepared as an account of the work sponsored by the Air Force. Neither the United States Government, the Air Force, nor any of their employees makes any warranty, express or implied, or assumes any legal liability or responsibility for the accuracy, completeness, or usefulness of any information, apparatus, product, or process disclosed, nor represents that its use would not infringe on privately owned rights. Reference herein to any specific commercial products, process, or service by trade name, trademark, manufacturer, or otherwise, does not necessarily constitute or imply its endorsement, recommendation, or favoring by the United States Government or the Air Force. The views and opinions of authors expressed herein do not necessarily state or reflect those of the United States Government or the Air Force, and shall not be used for advertising or product endorsement purposes.

Available to the public from the
National Technical Information Service
U.S. Department of Commerce
5285 Port Royal Road
Springfield, VA 22161

This report and those involved in its preparation do not endorse any product, process, or company stated herein. Use of these means by anyone does not imply certification by the Air Force CALS Test Network (AFCTN).

Contents

1.	Introduction.....	1
1.1.	Background.....	1
1.2.	Purpose.....	2
2.	Test Parameters.....	3
3.	1840A Analysis.....	5
3.1.	External Packaging.....	5
3.2.	Transmission Envelope.....	5
3.2.1.	Tape Formats.....	5
3.2.2.	Declaration and Header Fields.....	6
4.	IGES Analysis.....	6
5.	SGML Analysis.....	6
6.	Raster Analysis.....	7
7.	CGM Analysis.....	8
8.	Conclusions and Recommendations.....	9
9.	Appendix A - Tape Tool Report Logs.....	10
9.1.	Tape Catalog.....	10
9.2.	Tape Evaluation Log.....	11
9.3.	Tape File Set Validation Log.....	13
10.	Appendix B - SGML Detail Analysis.....	15
10.1.	ArbortText Parser Log.....	15
10.2.	Exoterica Validator exl 2.0.....	15
11.	Appendix C - Detail Raster Analysis.....	19

11.1. File D001R026.....19
 11.1.1. Output IGESView.....19
11.2. File D001R031.....20
 11.2.1. Output IGESView.....20
11.3. File D001R116.....21
 11.3.1. Output IGESView.....21

1. Introduction

1.1 Background

The Department of Defense (DoD) Air Force Continuous Acquisition and Life-cycle Support (CALs) Test Network (AFCTN) is conducting tests of the military standard for the Automated Interchange of Technical Information, MIL-STD-1804A, and its companion suite of military specifications. The AFCTN is a DoD sponsored confederation of voluntary participants from industry and the government managed by the Electronic Systems Center (ESC).

The primary objective of the AFCTN is to evaluate the effectiveness of the CALs standards for technical data interchange and to demonstrate the technical capabilities and categories of tests are performed to evaluate the standards; formal and informal.

Formal tests are large and comprehensive, which follow a written test plan, require specific authorization from the DoD, and may take months to prepare, execute, and report.

Informal tests are quick and short, used by the AFCTN technical staff, to broaden the testing base. They include representative samples of the many systems and applications used by AFCTN participants. They also allow the AFCTN staff to gain feedback from many industry and government interpretations of the standards, to increase the base of participation in the CALs initiative, and respond to the many requests for help that come from participants. Participants take part voluntarily, benefit by receiving an evaluation of their latest implementation (interpretation) of the standards, interact with the AFCTN technical staff, gain experience using the standards, and develop increased confidence in them. The results of informal tests are reported in Quick Short Test Reports (QSTRs) that briefly summarize the standard(s) tested, the hardware and software used, the nature of the test, and the results.

1.2 Purpose

The purpose of the informal test, reported in this QSTR, was to analyze IBM SID Boulder's interpretation and use of the CALS standards in transferring technical publication data. IBM SID used its CALS Technical Data Interchange System to produce data, in accordance with the standards, and delivered it to the AFCTN technical staff on a 9-track magnetic tape.

2. Test Parameters

Test Plan: AFCTB 93-070

Date of Evaluation: 12 July 1993

Evaluator: George Elwood
Air Force CALS Test Bed
DET 2 HQ ESC/AV-2P
4027 Colonel Glenn Hwy.
Suite 300
Dayton OH 45431-1672

Data Originator: Ina Dickinson
IBM SID Boulder
685 Citadeo Dr. East, Suite 400
Colorado Springs, CO 80909

Data Description: Technical Manual Test
1 Document Declaration file
1 Document Type Definition (DTD)
1 Text/Standard Generalized Markup Language (SGML) file
167 Raster files

Data Source System: 1840

HARDWARE
Unknown

SOFTWARE
IBM

Text/SGML

HARDWARE
Unknown

SOFTWARE
Unknown

Raster

HARDWARE
Unknown

SOFTWARE
Unknown

Evaluation Tools Used:

MIL-STD-1840A (TAPE)

SUN 3/280

AFCTN Tapetool v1.2.10 UNIX

XSoft CAPS/CALS v40.4

Texas Instruments (TI) Tapetool v1.0.1

PC 486/50

AFCTN Tapetool v1.2.10 DOS

MIL-M-28001A (SGML)

PC 486/50

Exoterica XGMLNormalizer v1.2e3.2

Exoterica Validator v2.0 ex1

Public Domain sgmls

MIL-R-28002A (Raster)

SUN SparcStation 2

Carberry CADLeaf Plus v3.1

AFCTN validg4

AFCTN calstb.475

IGES Data Analysis (IDA) IGESView v3.0

Island Graphics IslandPaint v3.0

PC 486/50

AFCTN validg4

IDA IGESView Windows

Inset Systems HiJaak Window v1.0

Standards

Tested:

MIL-STD-1840A

MIL-M-28001A

MIL-R-28002A

MIL-D-28003

3. 1840A Analysis

3.1 External Packaging

The tape arrived at the Air Force CALS Test Bed (AFCTB) enclosed in a box in accordance with ASTM D 3951. The exterior of the box was marked with a magnetic tape warning label, as required by MIL-STD-1840A, para. 5.3.1.3.

The tape was enclosed in barrier sheet material as required by MIL-STD-1840A, para. 5.3.1.2. Inspection of the tape reel showed a label indicating the recording density, as required by MIL-STD-1840A, para. 5.3.1. Enclosed in the box was a packing list showing all files recorded on the tape.

3.2 Transmission Envelope

The 9-track tape received by the AFCTB contained MIL-STD-1840A files. The files were named per the standard conventions.

3.2.1 Tape Formats

The tape was run through the AFCTN *Tapetool v1.2.10* utility. No errors were encountered while evaluating the contents of the tape labels.

The tape was read using XSoft's *CAPS read1840A* utility without any reported errors.

The tape was read using TI's *Tapetool v1.0.1* without any reported errors.

The physical tape structure meets the CALS MIL-STD-1840A requirements.

3.2.2 Declaration and Header Fields

No error were found in the Document Declaration file and data file headers.

This portion of the tape meets the CALS MIL-STD-1840A requirements.

4. IGES Analysis

The tape contained no Initial Graphics Exchange Specification (IGES) files.

5. SGML Analysis

The tape contained one DTD and Text file. The Text file was over 1Meg and as such could not be parsed by some of the tools available in the AFCTB.

The AFCTB has several parsers available for evaluating submitted DTD and Text files. These tools are not used to generate a pass/fail but to report how commercially available software can handle the files. These products are used in the development of technical publications and are good indicators of usability. The use of these products is not an endorsement nor an indication of CALS capability. All operations were performed using the default settings unless specified in the report. Changes to DTD or Text files required by each system are not documented in the report.

The Text and DTD files were evaluated using the Exoterica *Validator ex1* parser. No errors were reported, but 27 warnings were issued during the evaluation.

Per Ina Dickinson of IBM SID Boulder, "Our product used MIL-M-28001 as specified contractually with our customer; therefore, testing against 28001A may have caused the warnings."

The Text and DTD files were tested using the Exoterica *XGMLNormalizer* parser with no reported errors.

The Text and DTD files were evaluated using the Public Domain *sgmls* parser with no reported errors.

The SGML files meet the CALS MIL-M-28001A specification.

6. Raster Analysis

The tape contained 167 Raster files. All files were evaluated using the AFCTN *validg4* utility. This program reported that all 167 files meet the CALS MIL-R-28002A specification.

The files were read into the AFCTN *calstb.475* viewing utility. No problems were noted.

The AFCTB has several tools for viewing Raster files. These tools are not used to generate a pass/fail but to report how commercially available software can handle the files. Many of these products are used in the development of technical publications and are good indicators of usability. The use of these products is not an endorsement nor an indication of CALS capability. All operations were performed using the default settings.

The two files were converted using a utility available within the AFCTB without a reported error. The resulting files were read into Island Graphics' *IslandPaint*, displayed and printed in the completed document.

The Raster files were read into Carberry's *CADLeaf* software without a reported error. The images were displayed without a problem.

The files were read into IDA's *IGESView* and *IGESView for Windows* without a reported error. A sample of the files were printed and are included in the Appendix to this report.

The files were read into Inset Systems' *HiJaak for Windows* without a reported error.

The files were converted, using Inset Systems' *HiJaak for DOS*, into an IMG format without a reported error. The resulting files were read into Corel's *Ventura Publisher* and displayed.

The Raster files were converted using Rosetta Technologies' *Prepare* without a reported error. The resulting files were read into Rosetta Technologies' *Preview* and displayed.

The Raster files meet the CALS MIL-R-28002A specification.

7. CGM Analysis

The tape contained no Computer Graphics Metafile (CGM) files.

8. Conclusions and Recommendations

The physical structure of the tape from IBM SID Boulder meets the CALS MIL-STD-1840A requirements.

The SGML files meet the CALS MIL-M-28001A specification.

The Raster files meet the CALS MIL-R-28002A specification.

The tape meets the CALS MIL-STD-1840A requirements.

9. Appendix A - Tapetool Report Logs

9.1 Tape Catalog

Air Force CALS Test Network Catalog Evaluation - Version 1.2; Release 10 (U)

Standards referenced:

- MIL-STD-1840A (1987) - Automated Interchange of Technical Information
- ANSI X3.27 (1987) - File Structure and Labeling of Magnetic Tapes
for Information Interchange
- ANSI X3.4 (1986) - Coded Character Sets - 7 Bit ASCII

Fri Jul 9 16:23:14 1993

MIL-STD-1840A File Catalog

File Set Directory: /cals/u1210/Set001

Page: 1

File Name	File Type	Record Format/ Selected/ Length	Block Length/Total
----- D001 Extracted	Document Declaration	D/00260	02048/000001
D001T001 Extracted	Text	D/00260	02048/000527
D001G002 Extracted	DTD	D/00260	02048/000015
D001R003 Extracted	Raster	F/00128	02048/000005

<<<<< PART OF LOG FILE REMOVED HERE >>>>>

D001R168 Extracted	Raster	F/00128	02048/000056
D001R169 Extracted	Raster	F/00128	02048/000065

Catalog Process terminated normally.

9.2 Tape Evaluation Log

Air Force CALS Test Network Tape Evaluation - Version 1.2; Release 10 (U)

Standards referenced:

- ANSI X3.27 (1987) - File Structure and Labeling of Magnetic Tapes
for Information Interchange
- ANSI X3.4 (1986) - Coded Character Sets - 7 Bit ASCII

Fri Jul 9 16:20:21 1993

ANSI Tape Import Log

Allocating tape drive /dev/rmt0...

/dev/rmt0 allocated.

VOL1CTN501

SCPLLH

4

Label Identifier: VOL1
Volume Identifier: CTN501
Volume Accessibility:
Owner Identifier: SCPLLH
Label Standard Version: 4

HDR1D001

CTN50100010001000100 93188 93188 000000

Label Identifier: HDR1
File Identifier: D001
File Set Identifier: CTN501
File Section Number: 0001
File Sequence Number: 0001
Generation Number: 0001
Generation Version Number: 00
Creation Date: 93188
Expiration Date: 93188
File Accessibility:
Block Count: 000000
Implementation Identifier:

HDR2D0204800260

00

Label Identifier: HDR2
Recording Format: D
Block Length: 02048
Record Length: 00260
Offset Length: 00

9.3 Tape File Set Validation Log

Air Force CALS Test Network File Set Evaluation - Version 1.2; Release 10 (U)

Standards referenced:

MIL-STD-1840A (1987) - Automated Interchange of Technical Information

Fri Jul 9 16:23:15 1993

MIL-STD-1840A File Set Evaluation Log

File Set: Set001

Found file: D001

Extracting Document Declaration Header Records...

Evaluating Document Declaration Header Records...

srcsys: IBM, Federal Systems Division, Boulder, CO, BLDFVM5

srcdocid: MCC3MSTR SGMLRSLV

srcrelid: NONE

chglvl: ORIGINAL

dteisu: 19930616

dstsys: Air Force CALS Test Network, Wright-Patterson AFB, OH 45433

dstdocid: T.O. 31S5-2FSQ196-1

dstrelid: NONE

dtetrm: 19930707

dlvacc: NONE

filcnt: T1, G1, R167

ttlcls: Unclassified

doccls: Unclassified

doctyp: ORGANIZATIONAL SUBSYSTEM OPERATIONS AND MAINTENANCE INSTRUCTIONS WITH
CIRCUIT DIAGRAMS AND ILLUSTRATED PARTS BREAKDOWN

doctl: SATELLITE OPERATIONS COMPLEX/NETWORK CONTROL SEGMENT (SOC/NCS)

SATELLITE CONFIGURATION CONTROL SYSTEM AN/FSQ-196 MISSION CONTROL COMPLEX-3
(MCC-3)

Found file: D001T001

Extracting Text Header Records...

Evaluating Text Header Records...

srcdocid: MCC3MSTR SGMLRSLV

dstdocid: T.O. 31S5-2FSQ196-1

txtfilid: W

doccls: Unclassified

notes: NONE

Saving Text Header File: D001T001_HDR

Saving Text Data File: D001T001_TXT

Found file: D001G002
Extracting DTD Header Records...
Evaluating DTD Header Records...

srcdocid: MCC3MSTR SGMLRSLV
dstdocid: T.O. 31S5-2FSQ196-1
notes: NONE

Saving DTD Header File: D001G002_HDR
Saving DTD Data File: D001G002_DTD

Found file: D001R003
Extracting Raster Header Records...
Evaluating Raster Header Records...

srcdocid: MCC3MSTR SGMLRSLV
dstdocid: T.O. 31S5-2FSQ196-1
txtfilid: W
figid: 1-1
srcgph: mcc30114
doccls: Unclassified
rtype: 1
rorient: 000,270
rpelcnt: 001440,001344
rdensty: 0240
notes: NONE

Saving Raster Header File: D001R003_HDR
Saving Raster Data File: D001R003_GR4

<<<<< PART OF LOG FILE REMOVED HERE >>>>>

Evaluating numbering scheme...
No errors were encountered during numbering scheme evaluation.
Numbering scheme evaluation complete.

Checking file count...
No errors were encountered during file count verification.
File Count verification complete.

No errors were encountered in Document D001.

No errors were encountered in this File Set.

MIL-STD-1840A File Set Evaluation Complete.

10. Appendix B - Detailed SGML Analysis

10.1 Parser Log

10.2 Exoterica Validator exl 2.0

```
<!-- **Warning** in "9370.sgm", line 685:
  An element with mixed content should permit data characters ("PCDATA")
  everywhere.
  The element being declared is "NOMEN".
                                     ftnote*) >
                                     ^
-->
<!-- **Warning** in "9370.sgm", line 756:
  An element with mixed content should permit data characters ("PCDATA")
  everywhere.
  The element being declared is "NOTICE".
  <!ELEMENT notice - o ((#PCDATA | %asyntxt;)*, ftnote*) >
                                     ^
-->
<!-- **Warning** in "9370.sgm", line 773:
  An element with mixed content should permit data characters ("PCDATA")
  everywhere.
  The element being declared is "PHRASE".
  <!ELEMENT phrase - o (((%text1; | %text2;)*, ftnote*)) >
                                     ^
-->
<!-- **Warning** in "9370.sgm", line 777:
  An element with mixed content should permit data characters ("PCDATA")
  everywhere.
  The element being declared is "OADR".
  <!ELEMENT oadr - o (((%text1; | %text2;)*, ftnote*)) >
                                     ^
-->
<!-- **Warning** in "9370.sgm", line 846:
  An element with mixed content should permit data characters ("PCDATA")
  everywhere.
  The element being declared is "ITEM".
  <!ELEMENT item - o (((%text1; | %text2;)*, ftnote*), (%list;)?) >
                                     ^
-->
<!-- **Warning** in "9370.sgm", line 859:
  An element with mixed content should permit data characters ("PCDATA")
  everywhere.
  The element being declared is "TERM".
  <!ELEMENT term - o ((#PCDATA | %asyntxt;)*, ftnote*) >
                                     ^
```

```
-->
<!-- **Warning** in "9370.sgm", line 863:
  An element with mixed content should permit data characters ("#PCDATA")
  everywhere.
  The element being declared is "INTLSTAN".
  <!ELEMENT intlstan - o ((#PCDATA | %asyntxt;)*, ftnote*) >
                                     ^
-->
<!-- **Warning** in "9370.sgm", line 871:
  An element with mixed content should permit data characters ("#PCDATA")
  everywhere.
  The element being declared is "PURPOSE".
  <!ELEMENT purpose - o ((#PCDATA | %asyntxt;)*, ftnote*) >
                                     ^
-->
<!-- **Warning** in "9370.sgm", line 875:
  An element with mixed content should permit data characters ("#PCDATA")
  everywhere.
  The element being declared is "SIGNER".
  <!ELEMENT signer - o ((#PCDATA | %asyntxt;)*, ftnote*) >
                                     ^
-->
<!-- **Warning** in "9370.sgm", line 925:
  An element with mixed content should permit data characters ("#PCDATA")
  everywhere.
  The element being declared is "PRECAUT".
  <!ELEMENT precaut - o ((#PCDATA | %asyntxt;)*, ftnote*) >
                                     ^
-->
<!-- **Warning** in "9370.sgm", line 995:
  An element with mixed content should permit data characters ("#PCDATA")
  everywhere.
  The element being declared is "TITLE".
  <!ELEMENT title - o (((%text1; | %text2;)*, ftnote*)) -(table | figure | ch
                                     ^
-->
<!-- **Warning** in "9370.sgm", line 999:
  An element with mixed content should permit data characters ("#PCDATA")
  everywhere.
  The element being declared is "DEF".
  <!ELEMENT def - o (((%text1; | %text2;)*, ftnote*) | paratext | table) >
                                     ^
-->
<!-- **Warning** in "9370.sgm", line 1003:
  An element with mixed content should permit data characters ("#PCDATA")
  everywhere.
  The element being declared is "PARATEXT".
  <!ELEMENT paratext - o (((%text1; | %text2;)*, ftnote*)) >
```

```
-->
<!-- **Warning** in "9370.sgm", line 1007:
  An element with mixed content should permit data characters ("#PCDATA")
  everywhere.
  The element being declared is "PARA".
  <!ELEMENT para - o (((%text1; | %text2;)*, footnote*) | %spcpara;) +(figure |
-->

-->
<!-- **Warning** in "9370.sgm", line 1055:
  An element with mixed content should permit data characters ("#PCDATA")
  everywhere.
  The element being declared is "ENTRY".
  <!ELEMENT entry - o (((%text1; | %text2;)*, footnote*) | %spcpara; | paratext
-->

-->
<!-- **Warning** in "9370.sgm", line 1117:
  An element with mixed content should permit data characters ("#PCDATA")
  everywhere.
  The element being declared is "FTNOTE".
  <!ELEMENT ftnote - - (((%text1; | %text2;)*, footnote*) | %list; |
-->

-->
<!-- **Warning** in "9370.sgm", line 1124:
  An element with mixed content should permit data characters ("#PCDATA")
  everywhere.
  The element being declared is "INDXFLAG".
  <!ELEMENT indxflag - - (((%text1; | %text2;)*, footnote*)) >
-->

-->
<!-- **Warning** in "9370.sgm", line 1200:
  An element with mixed content should permit data characters ("#PCDATA")
  everywhere.
  The element being declared is "LIN".
  <!ELEMENT lin - o ((#PCDATA | %asyntxt;)*, footnote*) >
-->

-->
<!-- **Warning** in "9370.sgm", line 1204:
  An element with mixed content should permit data characters ("#PCDATA")
  everywhere.
  The element being declared is "FIGINDEX".
  <!ELEMENT figindex - o ((#PCDATA | %asyntxt;)*, footnote*) >
-->

-->
<!-- **Warning** in "9370.sgm", line 1208:
  An element with mixed content should permit data characters ("#PCDATA")
  everywhere.
  The element being declared is "REFDES".
  <!ELEMENT refdes - o ((#PCDATA | %asyntxt;)*, footnote*) >
```

```
-->
<!-- **Warning** in "9370.sgm", line 1216:
  An element with mixed content should permit data characters ("#PCDATA")
  everywhere.
  The element being declared is "PARTDESC".
  <!ELEMENT partdesc - o ((#PCDATA | %asyntxt;)*, ftnote*) >
                                     ^
-->
<!-- **Warning** in "9370.sgm", line 1224:
  An element with mixed content should permit data characters ("#PCDATA")
  everywhere.
  The element being declared is "SSSN".
  <!ELEMENT sssn - o ((#PCDATA | %asyntxt;)*, ftnote*) >
                                     ^
-->
<!-- **Warning** in "9370.sgm", line 1236:
  An element with mixed content should permit data characters ("#PCDATA")
  everywhere.
  The element being declared is "MATERIAL".
  <!ELEMENT material - - ((#PCDATA | %asyntxt;)*, ftnote*) >
                                     ^
-->
<!-- **Warning** in "9370.sgm", line 1258:
  An element with mixed content should permit data characters ("#PCDATA")
  everywhere.
  The element being declared is "SUBSCRPT".
  <!ELEMENT subscrpt - - ((#PCDATA | %asyntxt;)*, subscrpt?, supscrpt?) >
                                     ^
-->
<!-- **Warning** in "9370.sgm", line 1271:
  An element name specified in a USEMAP declaration, ATTLIST declaration or
  content model is not defined by an ELEMENT declaration.
  The element name is "SUPSCRPT".
-->
<!-- **Warning** in "9370.sgm", line 1271:
  An element name specified in a USEMAP declaration, ATTLIST declaration or
  content model is not defined by an ELEMENT declaration.
  The element name is "SUPSCRPT".
-->
<!-- **Warning** in "9370.sgm", line 29240:
  There is no element with an IDREF or IDREFS attribute value equal to a
  specified ID value.
  The unreferenced ID attribute value is "IPB3T045".
-->
<!-- 27 warnings reported. -->
```

11. Appendix C - Detailed Raster Analysis

11.1 File D001R026

11.1.1 Output IGESView

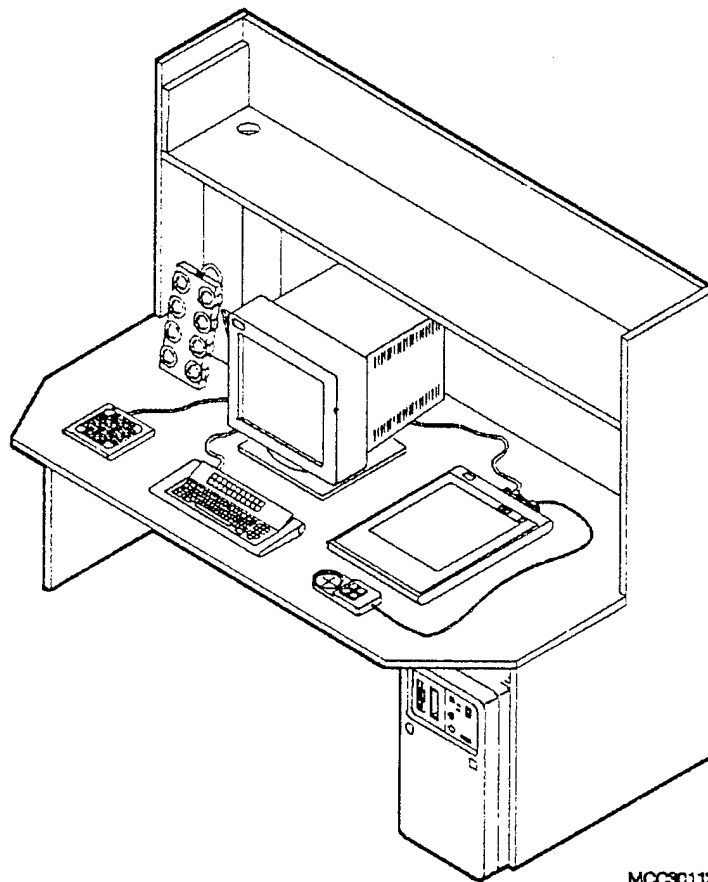

11.2 File D001R031

11.2.1 Output IGESView

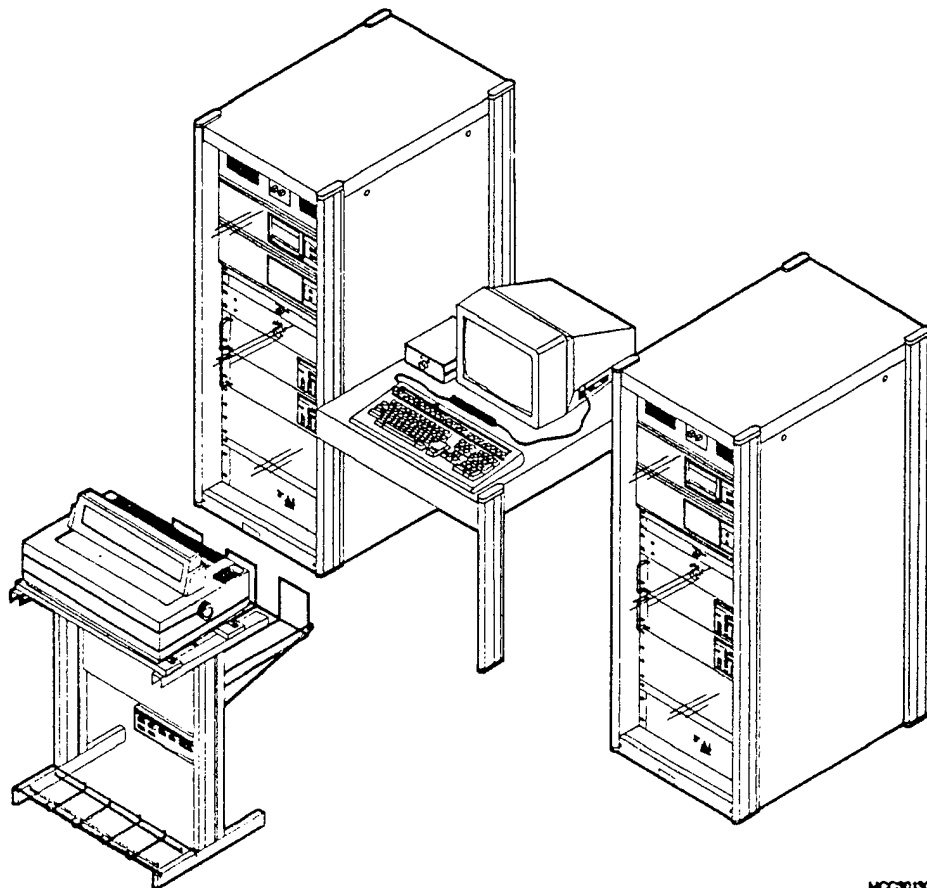

11.3 File D001R116

11.3.1 Output IGESView

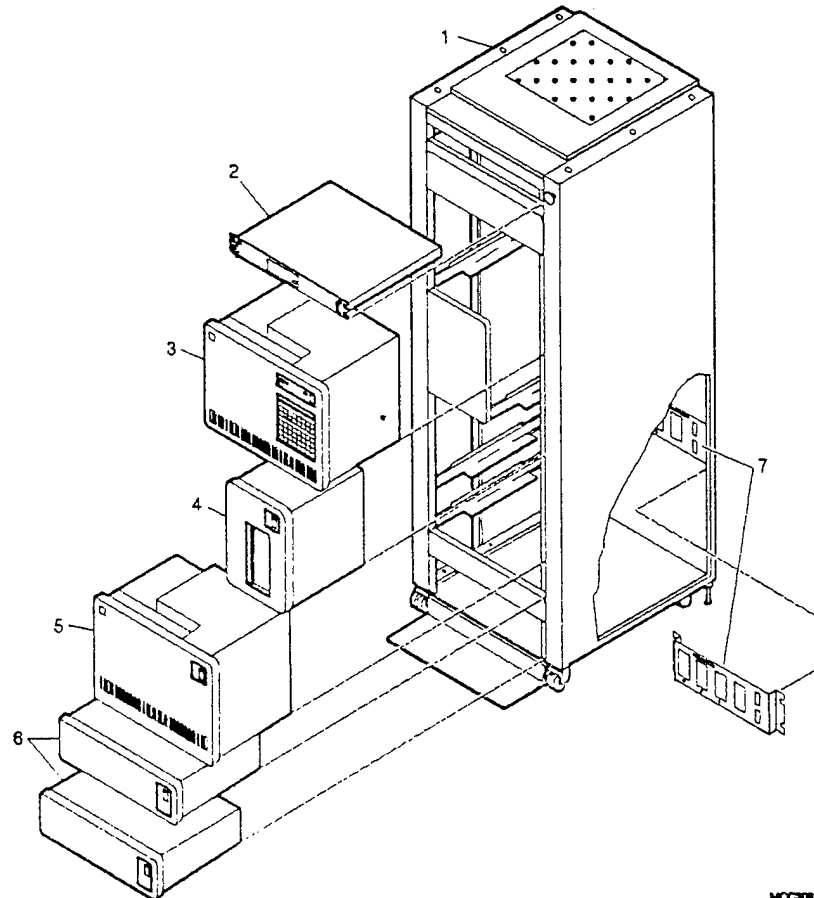

MCC0019