



AFCTN Report 94-080

AFCTB-ID
94-038



Technical Manual Transfer Using:

T.O. 31R2-2FRC181-42



Raytheon Company's Data Supporting:

ESC/MSK's MILSTAR Program

(Contract #F19628-89-C-0131/LRIP)



MIL-STD-1840A

MIL-D-28000A (IGES)

MIL-M-28001A (SGML)

MIL-D-28003 (CGM)



Quick Short Test Report

08 May 1994

19960822 056



Prepared for
Electronic Systems Center
Air Force CALS Program Office
HQ ESC/AV-2
4027 Colonel Glenn Hwy Suite 300
Dayton OH 45431-1672

DTIC QUALITY INSPECTED 3

DISTRIBUTION STATEMENT A

Approved for public release;
Distribution Unlimited

**Technical Manual Transfer
TO 31R2-2FRC181-42**

Using:

**Raytheon Company's Data Supporting:
ESC/MSK's MILSTAR Program**

(Contract #F19628-89-C-0131/LRIP)

MIL-STD-1840A

MIL-D-28000A (IGES)

MIL-M-28001A (SGML)

MIL-D-28003 (CGM)

Quick Short Test Report

08 May 1994

Prepared By

Air Force CALS Test Bed
Wright-Patterson AFB, OH 45433

AFCTB Contact

Gary Lammers
(513) 427-2295

AFCTN Contact

Mel Lammers
(513) 427-2295

DTIC QUALITY INSPECTED 3

DISCLAIMER

This document was prepared as an account of the work sponsored by the Air Force. Neither the United States Government, the Air Force, nor any of their employees makes any warranty, express or implied, or assumes any legal liability or responsibility for the accuracy, completeness, or usefulness of any information, apparatus, product, or process disclosed, nor represents that its use would not infringe on privately owned rights. Reference herein to any specific commercial products, process, or service by trade name, trademark, manufacturer, or otherwise, does not necessarily constitute or imply its endorsement, recommendation, or favoring by the United States Government or the Air Force. The views and opinions of authors expressed herein do not necessarily state or reflect those of the United States Government or the Air Force, and shall not be used for advertising or product endorsement purposes.

Available to the public from the
National Technical Information Service
U.S. Department of Commerce
5285 Port Royal Road
Springfield, VA 22161

This report and those involved in its preparation do not endorse any product, process, or company stated herein. Use of these means by anyone does not imply certification by the Air Force CALS Test Network (AFCTN).

Air Force CALS Test Bed

Notification of Test Results

08 May 1994

This notice documents the results of an Air Force CALS Test Bed (AFCTB) Quick Short Test Report (QSTR) evaluation of data submitted by:

Raytheon Company

Identified as follows:

Title:	Technical Manual Transfer TO 31R2-2FRC181-42
Program:	MILSTAR
Program Office:	ESC/MSK
Contract No.:	F19628-89-C-0131/LRIP
QSTRNo.:	AFCTB-ID 94-038

Received on the following media: **9-Track Tape**

The results of the AFCTB Quick Short Test evaluation are as follows:

MIL-STD-1840A Standard	Pass
MIL-STD-1840A Media Format:	Pass
MIL-D-28000A IGES:	Pass
MIL-M-28001A SGML:	Pass
MIL-R-28002A Raster:	N/A
MIL-D-28003 CGM:	Pass

Formal results with associated disclaimer are documented and available from the AFCTB.

**Air Force CALS Test Bed
HQ ESC/AV-2P
4027 Colonel Glenn Highway, Suite 300
Dayton, OH 45431-1672
Phone: 513-257-3085 FAX: 513-257-5881**

Contents

1.	Introduction.....	1
1.1.	Background.....	1
1.2.	Purpose.....	2
2.	Test Parameters.....	3
3.	1840A Analysis.....	6
3.1.	External Packaging.....	6
3.2.	Transmission Envelope.....	6
3.2.1.	Tape Formats.....	6
3.2.2.	Declaration and Header Fields.....	7
4.	IGES Analysis.....	7
5.	SGML Analysis.....	9
6.	Raster Analysis.....	10
7.	CGM Analysis.....	10
8.	Conclusions and Recommendations.....	13
9.	Appendix A - Tapetool Report Logs.....	14
9.1.	Tape Catalog.....	14
9.2.	Tape Evaluation Log.....	15
9.3.	Tape File Set Validation Log.....	16
9.4.	Other Tape Reading Logs.....	20

- 10. Appendix B - Detailed IGES Analysis.....21
 - 10.1. File D001Q020.....21
 - 10.1.1. Parser/Verifier Log.....21
 - 10.1.2. Parser Log - IGESWorks.....27
 - 10.1.3. Output CADLeaf.....30
 - 10.1.4. Output CALSView31
 - 10.1.5. Output IGESView.....32
 - 10.1.6. Output iges2draw/IslandDraw.....33
 - 10.1.6.1. Normal Translation.....33
 - 10.1.6.2. Bounded Data Translation....33
- 11. Appendix C - Detailed SGML Analysis.....34
 - 11.1. Parser Log.....34
 - 11.1.1. DTD Log File.....34
 - 11.2. Exoterica XGMLNormalizer Parser.....35
 - 11.3. Exoterica validator Parser.....35
 - 11.4. Sema Mark-it Log.....35
 - 11.5. Public Domain sgmls Log.....35
- 12. Appendix E - Detailed CGM Analysis.....37
 - 12.1. File D001C005.....37
 - 12.1.1. Parser Log MetaCheck.....37
 - 12.1.2. validcgm Log.....39
 - 12.1.3. Output CADLeaf.....40
 - 12.1.4. Output CALSView.....41
 - 12.1.5. Output cgm2draw/IslandDraw.....42

12.1.6.	Output Designer.....	43
12.1.7.	Output Freelance.....	44
12.1.8.	Output Harvard Graphics.....	45
12.1.9.	Output IslandDraw v4.0	46
12.1.10.	Output X-Change.....	47
12.1.11.	Output Ventura Publisher.....	48

1. Introduction

1.1 Background

The Department of Defense (DoD) Air Force Continuous Acquisition and Life-cycle Support (CALs) Test Network (AFCTN) is conducting tests of the military standard for the Automated Interchange of Technical Information, MIL-STD-1840A, and its companion suite of military specifications. The AFCTN is a DoD sponsored confederation of voluntary participants from industry and government managed by the Electronic Systems Center (ESC).

The primary objective of the AFCTN is to evaluate the effectiveness of the CALS standards for technical data interchange and to demonstrate the technical capabilities and operational suitability of those standards. Two general categories of tests are performed to evaluate the standards; formal and informal.

Formal tests are large and comprehensive, which follow a written test plan, require specific authorization from the DoD, and may take months to prepare, execute, and report.

Informal tests are quick and short, used by the AFCTN technical staff, to broaden the testing base. They include representative samples of the many systems and applications used by AFCTN participants. They also allow the AFCTN staff to gain feedback from many industry and government interpretations of the standards, to increase the base of participation in the CALS initiative, and respond to the many requests for help that come from participants. Participants take part voluntarily, benefit by receiving an evaluation of their latest implementation (interpretation) of the standards, interact with the AFCTN technical staff, gain experience using the standards, and develop increased confidence in them. The results of informal tests are reported in Quick Short Test Reports (QSTRs) that briefly summarize the standard(s) tested, the hardware and software used, the nature of the test, and the results.

1.2 Purpose

The purpose of the informal test, reported in this QSTR, was to analyze Raytheon's interpretation and use of the CALS standards in transferring technical manual data. Raytheon used its CALS Technical Data Interchange System to System to produce data, in accordance with the standards, and delivered it to the AFCTN technical staff on a 9-track magnetic tape. The delivered package is a sample of ESC/MSK's MILSTAR data delivered to the government.

2. Test Parameters

Test Plan: AFCTB 94-038

Date of Evaluation: 8 May 1994

Evaluator: George Elwood
Air Force CALS Test Bed
DET 2 HQ ESC/AV-2P
4027 Colonel Glenn Hwy
Suite 300
Dayton OH 45431-1672

Data Originator: James M. Leighton
Raytheon Company
Equipment Division
1001 Boston Post Road
Marlborough MA 01752
(508) 490-1332

Major William Kent
HQ ESC/MSK
MILSTAR Program
Hanscom AFB MA 01731-5000

Data Description: Technical Manual Test
1 Document Declaration file
4 Document Type Definitions (DTD)
13 Initial Graphics Exchange Specification (IGES) files
1 Text/Standard Generalized Markup Language (SGML) file
7 Computer Graphics Metafile (CGM) files

Data Source System: 1840

HARDWARE

Beta Testing Under Non-Disclosure

SOFTWARE

Beta Testing Under Non-Disclosure

IGES

HARDWARE

Beta Testing Under Non-Disclosure

SOFTWARE

Beta Testing Under Non-Disclosure

Text/SGML

HARDWARE

Beta Testing Under Non-Disclosure

SOFTWARE

Beta Testing Under Non-Disclosure

CGM

HARDWARE

Beta Testing Under Non-Disclosure

SOFTWARE

Beta Testing Under Non-Disclosure

Evaluation Tools Used:

MIL-STD-1840A (TAPE)

SUN 3/280

AFCTN Tapetool v1.2.10 UNIX

XSoft CAPS/CALS v40.4

MIL-D-28000 (IGES)

HP 735

InterCAP X-Change v7.82

SGI Indigo2

IGES Data Analysis (IDA) CALSView

Sun SparcStation 2

ArborText iges2draw

Carberry CADLeaf Plus v3.1

IDA Parser/Verifier v92

IDA IGESView v3.05

International TechneGroup Incorporated

(ITI) IGES/Works v1.3

Rosetta Technologies Prepare

Rosetta Technologies Preview v3.2

MIL-M-28001 (SGML)

SUN SparcStation 2

ArborText ADEPT v4.2.1

PC 486/50

Exoterica *XGMLNormalizer v1.2e3.2*
Exoterica *Validator v2.2 ex1*
SoftQuad *Author/Editor v2.1*
McAfee & McAdam *Sema Mark-it v2.3*
Public Domain *sgmls*

MIL-D-28003 (CGM)

HP 735

InterCAP X-Change v7.82

SGI Indigo 2

IDA CALSView

SUN SparcStation 2

ArborText cgm2draw

Carberry CADLeaf Plus v3.1

Island Software IslandDraw v3.0

Island Software IslandDraw v4.0

PC 486/50

Advanced Technology Center

(ATC) MetaCheck R 2.10

Software Publishing Corporation

(SPC) Harvard Graphics v3.05

Inset Systems HiJaak Pro

Lotus Freelance v2.01

Micrografx Designer v4.0

Corel Ventura Publisher

Standards

Tested:

MIL-STD-1840A

MIL-D-28000A

MIL-M-28001A

MIL-D-28003

3. 1840A Analysis

3.1 External Packaging

The tape arrived at the Air Force CALS Test Bed (AFCTB) enclosed in a commercial overnight padded bag. The exterior of the bag was marked with a magnetic tape warning label, as required by MIL-STD-1840A, para. 5.3.1.3.

The tape was not enclosed in a barrier bag or barrier sheet material, as required by MIL-STD-1840A, para. 5.3.1.2. Inspection of the tape reel showed the label indicating the recording density, as required by MIL-STD-1840A, para. 5.3.1. A packing list showing all files recorded on the tape was not enclosed.

3.2 Transmission Envelope

The 9-track tape received by the AFCTB contained MIL-STD-1840A files. The files were named per the standard conventions.

3.2.1 Tape Formats

The tape was run through the AFCTN *Tapetool v1.2.10* utility. No errors were encountered while evaluating the contents of the tape labels.

The tape was read using XSoft's *CAPS read1840A* utility without any reported errors. However, this utility process resulted in the loss of three of the four DTDs. This occurred because the four DTDs had identical destination system document (dstdocid) record values and the *CAPS read1840A* utility renames the files using the dstdocid record values. (MIL-STD-1840A permits identical dstdocid values for multiple files; MIL-STD-1840B corrected this problem).

The physical structure of the tape meets the CALS MIL-STD-1840A requirements.

3.2.2 Declaration and Header Fields

No errors were reported in the Document Declaration file and data file headers. This portion of the tape meets the CALS MIL-STD-1840A requirements.

4. IGES Analysis

The tape contained 13 IGES files. These files were evaluated using IDA's *parser/verifier* set for CALS Class I. This utility reported that all files meet the specification defined in MIL-D-28000A, Amendment 1. No CALS errors were reported; however, all files had some basic IGES errors. The reported errors were arcs with end points not meeting. These errors were not noticeable as viewed in a technical illustration.

The required conformance statement was found in the start section of all files.

The AFCTB has several tools for viewing IGES files. These tools are not used to generate a pass/fail but to report how commercially available software can handle the files. Many of these products are used in the development of technical publications and are good indicators of usability. The use of these products is not an endorsement nor an indication of CALS capability. All operations were performed using the default settings.

All files were viewed by at least three different utilities. Because of the number of submitted files, only two files were selected for detailed analysis.

The files were converted using ArborText's *iges2draw* utility with no reported errors. The resulting files were read into Island Software's *IslandDraw*, displayed and printed without a reported error. When viewed, some files only displayed part of the image. This is due to a negative value for the origin point of the drawing. Using an undocumented feature of the *iges2draw* utility, this problem can be corrected. In file D001Q020 additional lines were noted. This file had the arrowheads added using IGES entity 230, sectioned area. Part of the lines were to be blanked. The *iges2draw* utility did not blank these areas which resulted in extra lines added to the image.

According to Chris Moffett of ArborText, Inc., "This (or These) problem(s) may be due {to} the method in which the original file was generated."

The files were read into Carberry's *CADLeaf* software without a reported error. *CADLeaf* also displayed some partial images. These were also due to the negative X and Y origin points of the image being bound. When the "bound data" option was selected the entire image was displayed. This utility also displayed the added 230 entity lines.

The files were read using IDA's *CALSVIEW*. The complete image was displayed with this utility. The added lines from the entity 230 were displayed.

The files were read using IDA's *IGESVIEW* and *IGESVIEW for Windows*. The complete image was displayed with this product. The added lines from the entities 230 was also displayed in file D001Q020.

The files were read using InterCAPS's *X-Change*. The added lines in file D001Q020 were not noted in this application.

The files were read using ITI's *IGESWORKS* without a reported error. The files were displayed and printed. In file D001Q020 no arrowheads were displayed.

The IGES files meet the CALS MIL-D-28000A specification. Some basic IGES errors were reported, but these do not effect the displayed image in a technical manual. The negative origin point caused problems in some software applications. The use of entity 230, sectioned area to create arrowheads, resulted in added lines in some applications. These lines should have been blanked, but displayed.

5. SGML Analysis

The tape contained four DTD and one SGML files. The AFCTB has several parsers available for evaluating submitted DTD and text files. These tools are not used to generate a pass/fail but to report how commercially available software can handle the files. These products are used in the development of technical publications and are good indicators of usability. The use of these products is not an endorsement nor an indication of CALS capability. All operations were performed using the default settings unless specified in the report.

The text and DTD files were evaluated using another parser available within the AFCTB. This parser could not handle the "IGNORE" statements in the DTD. These were commented out and the DTDs parsed without a reported error.

The text and DTD files were evaluated using the Exoterica *Validator ex1* parser. One warning for a mixed content model was issued.

The text and DTD files were tested using the Exoterica *XGMLNormalizer* parser. No errors or warnings were issued by this utility.

The text and DTD files were evaluated using McAfee & McAdam's *Sema Mark-it v2.3* parser. No errors or warnings were issued by this utility.

The text and DTD files were evaluated using the Public Domain *sgmls* parser. This parser reported errors in the BSPEC DTD in the marked section area. It also reported errors for all graphics. The graphics callouts had been commented out by the AFCTB evaluation. Thus, the reported errors are not considered errors for this report.

The text file was imported into ArborText's *Adept* software. No errors were issued by the parser. Because no FOSI was available for this document type, it could not be published.

The text and DTD files meet the CALS MIL-M-28001A specification.

6. Raster Analysis

No Raster files were included in this evaluation.

7. CGM Analysis

The tape contained seven CGM files. The files were evaluated using ATC's *MetaCheck* with CALS options. This utility reported that all files meet the CALS MIL-D-28003 specification.

The CGM files were evaluated using the beta AFCTN *validcgm* utility. This utility did not report any errors in the files.

The AFCTB has several tools for viewing CGM files. These tools are not used to generate a pass/fail but to report how commercially available software can handle the files. Many of these products are used in the development of technical publications and are good indicators of usability. The use of these products is not an endorsement nor an indication of CALS capability. All operations were performed using the default settings.

The CGM files were converted using ArborText's *cgm2draw* utility without a reported error. The resulting files were read into Island Software's *IslandDraw v3.1*, displayed and printed. All files when initially displayed were black. The background color had to be removed in order to display the image. The word CAUTION, in the text of file D001C001, was longer than the graphic and not centered. The three columns of text in file D001C005 ran together.

The files were read into Carberry's *CADLeaf* software and displayed. The background color in all images had to be changed to white in order to display the graphic. The text in file D001C001 was longer than the graphic and not centered. The column text in file D001C005 overlapped.

The files were read into IDA's *CALSVIEW*. The background color had to be changed in order to display the image. The black background color had to be removed in order to view the images. The text in file D001C001 was centered on the graphic but was displayed as lines. The three column text in file D001C005 ran together.

The files were imported into the Micrografx *Designer* without a reported error. The background color was not an issue with these files. The text in file D001C001 was very small, covering approximately 5 percent of the area across the top of the graphic. The three column text in file D001C005 displayed correctly in this utility.

According to Michael Harrison of Micrografx, Inc., "Micrografx is aware of the problems associated with reading these files and is working on a solution to be implemented in a future release of our products."

The files were imported into Lotus' *Freelance* and displayed. The background color had to be removed in order to display the images. The text in file D001C001 was very small, covering approximately 5 percent of the area across the top of the graphic. The three column text in file D001C005 overlapped.

The files were imported into SPC's *Harvard Graphics v3.05* without a reported error. The background color had to be changed in order to display the image. The three column text in file D001C005 overlapped.

The files were read into Inset Systems' *HiJaak Pro* without a reported error. The background color had to be changed in order to display the images. The three column text in file D001C005 overlapped.

The files were imported directly into Island Software's *IslandDraw v4.0* without a reported error. The background color had to be changed in order to display the image. In file D001C001 the text did not display. The graphic image had additional areas displayed. Parts of the image did not display in file D001C005. The three column text displayed correctly.

The files were read into InterCAP's *X-Change* without a reported error. The background color had to be removed in order to display the image. The text in file D001C001 did not display correctly. The three column text in file D001C005 overlapped.

The files were imported into Corel's *Ventura Publisher* without a reported error. The background color was not an issue with this software. The text in file D001C001 was

very small. The three column text in file D001C005 displayed correctly.

While the CGM files meet the CALS MIL-D-28003 specification, all software applications in the AFCTB had problems with the them. Most applications required the background color be removed or changed before the image could be viewed. Text font problems were noted in some files.

8. Conclusions and Recommendations

The tape from Raytheon reported no errors in its physical structure or CALS headers, and meets the CALS MIL-STD-1840A requirements.

The IGES files meet the CALS MIL-D-28000A, Amendment One specification. However, some applications had problems with the negative origin point and the use of entity 230 (section area) for the arrowhead.

The SGML files meet the CALS MIL-M-28001A specification. The files could be parsed without a reported error. The use of multiple DTDs within the MIL-STD-1840A envelop may cause problems on some systems. If the files are renamed using information in the CALS header, which is identical in two or more DTDs, all but one of the DTDs will be lost.

The CGM files meet the CALS MIL-D-28003 specification. However, most software applications in the AFCTB had problems with the black background and graphics. The background had to be removed and the color changed in order to view the image. Text font problems cause text overlap and a wide range of sizes in different illustrations.

Even though the tape and submitted files meet the CALS MIL-STD-1840A requirements, work was necessary to make most of the graphic files usable in the systems available within the AFCTB.

9. Appendix A - Tapetool Report Logs

9.1 Tape Catalog

CALS Test Network Catalog Evaluation - Version 1.2; Release 10 (C)

Standards referenced:

- MIL-STD-1840A (1987) - Automated Interchange of Technical Information
- ANSI X3.27 (1987) - File Structure and labeling of Magnetic Tapes
for Information Interchange
- ANSI X3.4 (1986) - Coded Character Sets - 7 Bit ASCII

Fri May 6 13:33:31 1994

MIL-STD-1840A File Catalog

File Set Directory: /cals/u1210/Set067

Page: 1

File Name	File Type	Record Format/ Length	Block Length/Total	Selected/ Extracted
D001	Document Declaration	D/00260	02048/000001	Extracted
D001C001	CGM	F/00080	00800/000003	Extracted
D001C002	CGM	F/00080	00800/000003	Extracted
<<<<< PART OF LOG FILE REMOVED HERE >>>>>				
D001G008	DTD	D/00260	02048/000001	Extracted
D001G009	DTD	D/00260	02048/000013	Extracted
D001G010	DTD	D/00260	02048/000002	Extracted
D001G011	DTD	D/00260	02048/000002	Extracted
D001Q012	IGES	F/00080	02000/000106	Extracted
D001Q013	IGES	F/00080	02000/000023	Extracted
<<<<< PART OF LOG FILE REMOVED HERE >>>>>				
D001Q024	IGES	F/00080	02000/000058	Extracted
D001T025	Text	D/00260	02048/000034	Extracted

Catalog Process terminated normally.

9.2 Tape Evaluation Log

CALS Test Network Tape Evaluation - Version 1.2; Release 10 (C)

Standards referenced:

ANSI X3.27 (1987) - File Structure and labeling of Magnetic Tapes
for Information Interchange

ANSI X3.4 (1986) - Coded Character Sets - 7 Bit ASCII

Fri May 6 13:32:40 1994

ANSI Tape Import Log

Allocating tape drive /dev/rmt0...

/dev/rmt0 allocated.

VOL1ONA001

4

Label Identifier: VOL1
Volume Identifier: ONA001
Volume Accessibility:
Owner Identifier:
Label Standard Version: 4

HDR1D001 ONA00100010001000000 94077 00000 000000

Label Identifier: HDR1
File Identifier: D001
File Set Identifier: ONA001
File Section Number: 0001
File Sequence Number: 0001
Generation Number: 0000
Generation Version Number: 00
Creation Date: 94077
Expiration Date: 00000
File Accessibility:
Block Count: 000000
Implementation Identifier:

<<<<< PART OF LOG FILE REMOVED HERE >>>>>

End of Volume ONA001 #####
End Of Tape File Set

Deallocating /dev/rmt0...

Tape Import Process terminated normally.

9.3 Tape File Set Validation Log

CALS Test Network File Set Evaluation - Version 1.2; Release 10 (C)

Standards referenced:

MIL-STD-1840A (1987) - Automated Interchange of Technical Information

Fri May 6 13:33:31 1994

MIL-STD-1840A File Set Evaluation Log

File Set: Set067

Found file: D001

Extracting Document Declaration Header Records...

Evaluating Document Declaration Header Records...

srcsys: O'Neil & Assoc. CAGE 83007

srcdocid: TO 31R2-2FRC181-42

srcrelid: NONE

chglvl: ORIGINAL

dteisu: 19940303

dstsys: Raytheon CAGE 49956

stdocid: TO 31R2-2FRC181-42

dstrelid: NONE

dtetrn: 19940318

dlvacc: NONE

filcnt: C7,G4,Q13,T1

ttlcls: UNCLASSIFIED

doccls: UNCLASSIFIED

doctyp: Technical Publication

docttl: NONE

Found file: D001C001

Extracting CGM Header Records...

Evaluating CGM Header Records...

srcdocid: TO 31R2-2FRC181-42

stdocid: TO 31R2-2FRC181-42

txtfilid: W

figid: A

srcgph: ESDCAU

doccls: UNCLASSIFIED

notes: NONE

Saving CGM Header File: D001C001_HDR

Saving CGM Data File: D001C001_CGM

<<<< PART OF LOG FILE REMOVED HERE >>>>

Found file: D001G008
Extracting DTD Header Records...
Evaluating DTD Header Records...

srcdocid: TO 31R2-2FRC181-42
dstdocid: TO 31R2-2FRC181-42
notes: NONE

Saving DTD Header File: D001G008_HDR
Saving DTD Data File: D001G008_DTD

Found file: D001G009
Extracting DTD Header Records...
Evaluating DTD Header Records...

srcdocid: TO 31R2-2FRC181-42
dstdocid: TO 31R2-2FRC181-42
notes: BSPEC

Saving DTD Header File: D001G009_HDR
Saving DTD Data File: D001G009_DTD

Found file: D001G010
Extracting DTD Header Records...
Evaluating DTD Header Records...

srcdocid: TO 31R2-2FRC181-42
dstdocid: TO 31R2-2FRC181-42
notes: calstabs.sgm

Saving DTD Header File: D001G010_HDR
Saving DTD Data File: D001G010_DTD

Found file: D001G011
Extracting DTD Header Records...
Evaluating DTD Header Records...

srcdocid: TO 31R2-2FRC181-42
dstdocid: TO 31R2-2FRC181-42
notes: calstabs.sgm

Saving DTD Header File: D001G011_HDR
Saving DTD Data File: D001G011_DTD

Found file: D001Q012
Extracting IGES Header Records...
Evaluating IGES Header Records...

srcdocid: TO 31R2-2FRC181-42
dstdocid: TO 31R2-2FRC181-42
txtfilid: W
figid: 1-1
srcgph: M1001
doccls: UNCLASSIFIED
notes: NONE

Saving IGES Header File: D001Q012_HDR
Saving IGES Data File: D001Q012_IGS

<<<< PART OF LOG FILE REMOVED HERE >>>>

Found file: D001Q024
Extracting IGES Header Records...
Evaluating IGES Header Records...

srcdocid: TO 31R2-2FRC181-42
dstdocid: TO 31R2-2FRC181-42
txtfilid: W
figid: FO-5
srcgph: T4211
doccls: UNCLASSIFIED
notes: NONE

Saving IGES Header File: D001Q024_HDR
Saving IGES Data File: D001Q024_IGS

Found file: D001T025
Extracting Text Header Records...
Evaluating Text Header Records...

srcdocid: TO 31R2-2FRC181-42
dstdocid: TO 31R2-2FRC181-42
txtfilid: W
doccls: UNCLASSIFIED
notes: NONE

Saving Text Header File: D001T025_HDR
Saving Text Data File: D001T025_TXT

Evaluating numbering scheme...
No errors were encountered during numbering scheme evaluation.
Numbering scheme evaluation complete.

Checking file count...

No errors were encountered during file count verification.
File Count verification complete.

No errors were encountered in Document D001.

No errors were encountered in this File Set.

MIL-STD-1840A File Set Evaluation Complete.

9.4 Other Tape Reading Logs

```
/cals/caps/Bin/read1840A: --- Read declaration file 'D001 ' ---
/cals/caps/Bin/read1840A: writing data file 'aftb9438/TO31R2-2FRC181-4/ESDCAU.C.cgm'.
/cals/caps/Bin/read1840A: writing data file 'aftb9438/TO31R2-2FRC181-4/TXTRES.D.C.cgm'.
/cals/caps/Bin/read1840A: writing data file 'aftb9438/TO31R2-2FRC181-4/M1002.C.cgm'.
/cals/caps/Bin/read1840A: writing data file 'aftb9438/TO31R2-2FRC181-4/M1007.C.cgm'.
/cals/caps/Bin/read1840A: writing data file 'aftb9438/TO31R2-2FRC181-4/M1008.C.cgm'.
/cals/caps/Bin/read1840A: writing data file 'aftb9438/TO31R2-2FRC181-4/M1009.C.cgm'.
/cals/caps/Bin/read1840A: writing data file 'aftb9438/TO31R2-2FRC181-4/M1016.C.cgm'.
/cals/caps/Bin/read1840A: writing data file
'aftb9438/TO31R2-2FRC181-4/TO31R22FRC18142.G.dtd'.
/cals/caps/Bin/read1840A: writing data file
'aftb9438/TO31R2-2FRC181-4/TO31R22FRC18142.G.dtd'.
/cals/caps/Bin/read1840A: writing data file
'aftb9438/TO31R2-2FRC181-4/TO31R22FRC18142.G.dtd'.
/cals/caps/Bin/read1840A: writing data file
'aftb9438/TO31R2-2FRC181-4/TO31R22FRC18142.G.dtd'.
/cals/caps/Bin/read1840A: writing data file 'aftb9438/TO31R2-2FRC181-4/M1001.Q.igs'.
/cals/caps/Bin/read1840A: writing data file 'aftb9438/TO31R2-2FRC181-4/M1003A.Q.igs'.
/cals/caps/Bin/read1840A: writing data file 'aftb9438/TO31R2-2FRC181-4/M1004A.Q.igs'.
/cals/caps/Bin/read1840A: writing data file 'aftb9438/TO31R2-2FRC181-4/M1005A.Q.igs'.
/cals/caps/Bin/read1840A: writing data file 'aftb9438/TO31R2-2FRC181-4/M1006A.Q.igs'.
/cals/caps/Bin/read1840A: writing data file 'aftb9438/TO31R2-2FRC181-4/M1010A.Q.igs'.
/cals/caps/Bin/read1840A: writing data file 'aftb9438/TO31R2-2FRC181-4/M1011A.Q.igs'.
/cals/caps/Bin/read1840A: writing data file 'aftb9438/TO31R2-2FRC181-4/M1012A.Q.igs'.
/cals/caps/Bin/read1840A: writing data file 'aftb9438/TO31R2-2FRC181-4/M1013A.Q.igs'.
/cals/caps/Bin/read1840A: writing data file 'aftb9438/TO31R2-2FRC181-4/M1014A.Q.igs'.
/cals/caps/Bin/read1840A: writing data file 'aftb9438/TO31R2-2FRC181-4/M1015A.Q.igs'.
/cals/caps/Bin/read1840A: writing data file 'aftb9438/TO31R2-2FRC181-4/M10B22.Q.igs'.
/cals/caps/Bin/read1840A: writing data file 'aftb9438/TO31R2-2FRC181-4/T4211.Q.igs'.
/cals/caps/Bin/read1840A: writing data file 'aftb9438/TO31R2-2FRC181-4/W.T.sgm'.
-- declaration file indicates 1 files of type T
-- declaration file indicates 4 files of type G
-- declaration file indicates 0 files of type H
-- declaration file indicates 13 files of type Q
-- declaration file indicates 0 files of type R
-- declaration file indicates 7 files of type C
-- declaration file indicates 0 files of type X
-- declaration file indicates 0 files of type P
-- declaration file indicates 0 files of type Z
```

10. Appendix B - Detailed IGES Analysis

10.1 File D001Q020

10.1.1 Parser/Verifier Log

```
*****  
***** IGES PARSER/VERIFIER *****  
***** MARCH 1993 *****  
***** IGES Data Analysis *****  
***** (708) 344-1815 *****  
*****
```

Input file is q020.igs

Checking conformance to CALS Class I (MIL-D-28000A 2/10/92)
Today is May 6, 1994 2:42 PM

```
*****  
***** CHECK FILE SYNTAX *****  
*****
```

Section	Records
Start	5
Global	3
Directory	534 (267 Entities)
Parameter	320
Terminate	1

No syntax errors detected.

```
*****  
***** SUMMARY AND STATISTICS ****  
*****
```

*** File and Product Name Information ***

```
File name from sender      = 'M10.13.dwg'  
File creation Date.Time   = '940210.123030'  
Model change Date.Time   = ''  
Author                    = 'Gary Hahn'  
Department                 = ''  
Product name from sender  = 'Corel Expert'  
Destination product name = ''
```

*** Parameter Delimiters ***

Delimiter = ','
Terminator = ';'

*** Originating System Data ***

System ID = 'Corel Expert version 5.0'
Preprocessor version = '5.0'
Specification version = 6 (IGES 4.0)

*** Precision levels ***.

Integer bits = 16
Floating point - Exponent = 38 Mantissa = 7
Double precision - Exponent = 38 Mantissa = 7

*** Global Model Data ***

Model scale = 1.0000E+00
Unit flag = 1
Units = 'INCH'
Line weights = 3
Maximum line thickness = 4.166667E-02
Minimum line thickness = 1.388889E-02
Granularity = 1.000000E-05
Maximum coordinate = 1.491070E+01

Drafting standard applicable to original data is not specified.

*** Status Flag Summary ***

Blank status: Visible	267
Blanked	0
Independence: Independent	201
Physically Subordinate	64
Logically Subordinate	2
Totally Subordinate	0
Entity use: Geometry	218
Annotation	46
Definition	2
Other	1
Logical/Positional	0
2D parametric	0
Construction geometry	0
Not Specified	0

Hierarchy: Structure DE applies 267
 Subordinate DE applies 0
 Hierarchy property applies 0
 Not Specified 0

*** Entity Occurrence Counts ***

Entity	Form	Level	Count	Type
-----	----	-----	-----	----
100	0	0	3	Circular arc
102	0	0	9	Composite curve
104	1	0	3	Conic arc - ellipse
110	0	0	191	Line
124	0	0	3	Transformation matrix
212	0	0	46	General note
230	0	0	9	Sectioned area (Standard Crosshatching)
404	0	0	1	Drawing
406	16	0	1	Property - Drawing size
410	0	0	1	View - Orthographic parallel

*** Entity Count by Level ***

Level	Count
0	267

*** Labeling Information ***

100% of the entities are labeled.

Unlabeled 0

Label	Count	Label	Count	Label	Count
View	1*	Line	191*	GNote	46*
Arc	2*	Composit	9	Section	9*
Circle	1*	Matrix	3*	Ellipse	3*
Property	1	Drawing	1*		

NITPICK 2327: One or more of the flagged entity labels are not right-justified.

*** Line Fonts Used in Data ***

100	102	104	106	108	110	112	114	
-	-	-	-	-	-	-	-	Undefined
3	9	-	-	-	157	-	-	Solid
-	-	-	-	-	-	-	-	Dashed

-	-	-	-	-	-	-	-	-	Phantom
-	-	-	-	-	-	-	-	-	Center-line
-	-	3	-	-	34	-	-	-	Dotted
-	-	-	-	-	-	-	-	-	User defined
116	118	120	122	124	125	126	128		
-	-	-	-	-	-	-	-	-	Undefined
-	-	-	-	3	-	-	-	-	Solid

<<<< PART OF LOG FILE REMOVED HERE >>>>

*** Line Widths Used in Data ***

Weight	Count	Width
Defaulted	197	(0.0139)
1	70	(0.0139)

*** Colors Used in Data ***

Defaulted	24
Green	243

***** ENTITY ANALYSIS *****

*** Entity type: 100

*** Entity type: 102

ERROR 2033: End points of curves D 225 and D 227 disjoint by
7.470000E-02 at D 231.
ERROR 2033: End points of curves D 227 and D 229 disjoint by
7.209840E-02 at D 231.
ERROR 2033: Messages regarding disjoint composite curves suppressed.

*** Entity type: 104

WARNING 2265: Start point off conic by 1.594979E-05 at D 407.
WARNING 2039: End point off conic by 6.735962E-05 at D 407.
WARNING 2265: Start point off conic by 1.594979E-05 at D 427.
WARNING 2039: End point off conic by 6.735962E-05 at D 427.
WARNING 2265: Start point off conic by 1.594979E-05 at D 431.
WARNING 2039: End point off conic by 6.735962E-05 at D 431.

*** Entity type: 110

-- 191 lines averaging 6.068996E-01 units --

*** Entity type: 124

3 transformation matrices, 3 non-zero translations.

NOTE 2341: 3 matrices contain translation information.

*** Entity type: 212

46 text strings in data file.

Average text aspect ratio in file is 0.9024965.

Minimum text aspect ratio in file is 0.9008403.

Maximum text aspect ratio in file is 0.9071421.

FONTS USED IN FILE

FONT	COUNT	NAME
1	46	Default ASCII Style

*** Entity type: 230

NITPICK 2076: Entity does not have Annotation flag set at D 233.
NITPICK 2076: Entity does not have Annotation flag set at D 243.
NITPICK 2076: Entity does not have Annotation flag set at D 261.
NITPICK 2076: Entity does not have Annotation flag set at D 289.
NITPICK 2076: Entity does not have Annotation flag set at D 323.
NITPICK 2076: Entity does not have Annotation flag set at D 329.
NITPICK 2076: Entity does not have Annotation flag set at D 339.
NITPICK 2076: Entity does not have Annotation flag set at D 355.
NITPICK 2076: Entity does not have Annotation flag set at D 377.

*** Entity type: 404

NITPICK 2074: Entity use flag must be 1 for Drawing entity at D 533.
Drawing at D 533 contains 1 views.
Drawing at D 533 contains 0 annotation entities.

*** Entity type: 406

*** Entity type: 410

NITPICK 2073: Entity use flag must be 1 for View entity at D 1.
Scale of view at D 1 is 1.000000E+00.
Orthographic View entity at D 1 has 0 clipping planes specified.
XMIN = Not Set XMAX = Not Set
YMIN = Not Set YMAX = Not Set
ZMIN = Not Set ZMAX = Not Set

*** Message Summary ***

2007: 46 Mathematical discontinuities.
2015: 6 Mathematically incorrect definitions.
2016: 11 Invalid entity use flag.

*** Error Summary ***

0 fatal errors
0 severe errors
46 errors
6 warnings
0 cautions
12 nitpicks
1 notes

*** End of Analysis of q020.igs ***

10.1.2 Parser Log - IGESWorks

IGES/Works v1.4.1
International TechneGroup Incorporated
Validation Logfile

Date: May 09, 94 Model: q020

***** Validation Parameters *****

TOLERANCE CONFIGURATION VALUES

ZERO_TOL = 1.000000e-13
MODEL_SPACE_PNT_COIN_TOL = 1.000000e-03
PARM_SPACE_PNT_COIN_TOL = 1.000000e-08
ISO_PARM_CURVE_TOL = 1.000000e-08
NON_CONV_TOL = 1.000000e-12
KNOT_COIN_TOL = 1.000000e-10
SAME_INTER_TOL = 1.000000e-12
PARALLEL_LINES_TOL = 1.000000e-07
ANGLE_COIN_TOL = 1.000000e-05
PNT_PROJ_TOL = 1.000000e-07
COLIN_TOL = 1.000000e-07
COPLANAR_TOL = 1.000000e-08
ZERO_NORMAL_TOL = 1.000000e-06
SAME_TANGENT_TOL = 1.000000e-04
SAME_CURVATURE_TOL = 1.000000e-04
SAME_DERIVATIVE_TOL = 1.000000e-03
MODEL_LINEAR_APPROX_TOL = 2.220446e-16

***** Entity Listing Before Validation *****

Count	Type	Form	Description
-----	-----	----	-----
3	100	0	Circular Arc
9	102	0	Composite Curve
3	104	1	Ellipse
191	110	0	Line
3	124	0	Transformation Matrix
46	212	0	General Note (Simple)
9	230	0	Section Area (Standard Fill)
1	404	0	Drawing (form 0)
1	406	16	Property (Drawing Size)
1	410	0	View

267 - Number of entities in selection list

***** Entity Validation *****

*** Warning (IEVM_LABEL_NOT_RJ) ***

(DE 1, TF 410:0) The Label Display field in this entity's DE section was not

set for right justification.
Action taken: The Label Display field has been set to be right-justified.

<<<< PART OF LOG FILE REMOVED HERE >>>>

*** Warning (IEVM_NON_CONTINUOUS_102) ***
(DE 231, TF 102:0) This Composite Curve entity (102) is not continuous within the stated tolerance. The terminate point of the first curve does not equal the start point of the next curve.
Action taken: The curve was made continuous by the following actions.
DE 225 was reversed. DE 227 was reversed. DE 229 was reversed.

<<<< PART OF LOG FILE REMOVED HERE >>>>

*** Warning (IEVM_BAD_START_POINT_104) ***
(DE 407, TF 104:1) The start point for this Conic Arc entity (104) is not on the conic. Start point value found was -1.1200710e-01, 1.1631390e-01.
Action taken: The start point has been moved 7.7191029e-05 units, from -1.1200710e-01, 1.1631390e-01 to -1.1208429e-01, 1.1631390e-01.

*** Warning (IEVM_BAD_END_POINT_104) ***
(DE 407, TF 104:1) The end point for this Conic Arc entity (104) is not on the conic. Start point value found was 1.4170260e-01, 1.0923000e-01.
Action taken: The end point has been moved 2.4218468e-04 units, from 1.4170260e-01, 1.0923000e-01 to 1.4146042e-01, 1.0923000e-01.

<<<< PART OF LOG FILE REMOVED HERE >>>>

Entity Validation Summary:

Type	Form	Entity Count	Number Valid	Number of Corrected		Number of Uncorrected	
				Warnings	Errors	Warnings	Errors
Global Section		1	1	0	0	0	0
100	0	3	0	3	0	0	0
102	0	9	1	0	8	0	0
104	1	3	0	3	6	0	0
110	0	221	30	191	0	0	0
124	0	3	0	3	0	0	0
212	0	46	0	46	0	0	0
230	0	9	0	9	0	0	0
404	0	1	0	1	0	0	0
406	16	1	1	0	0	0	0
410	0	1	0	1	0	0	0
Totals:		298	33	257	14	0	0

The following message was issued and suppressed 252 times:

The Label Display field in this entity's DE section was not set for right justification.

The following message was issued and suppressed 3 times:

This Composite Curve entity (102) is not continuous within the stated tolerance. The terminate point of the first curve does not equal the start point of the next curve.

A message is suppressed when it has been issued more than 5 times. This value is controlled by the 'MAX_MESSAGE' configuration parameter.

10.1.3 Output CADLeaf

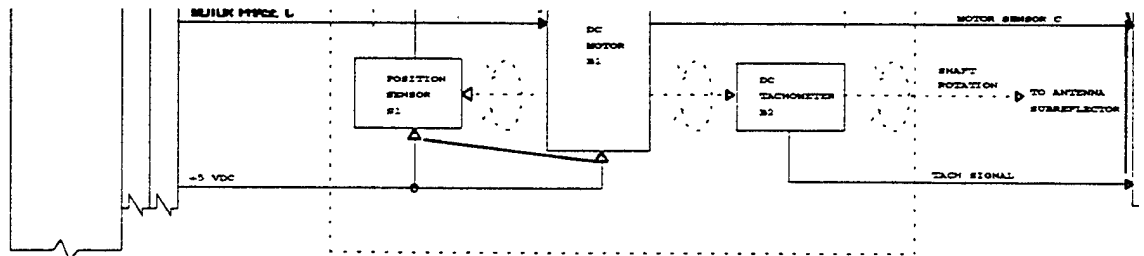

10.1.4 Output CALSView

CONSCAN MOTOR A2

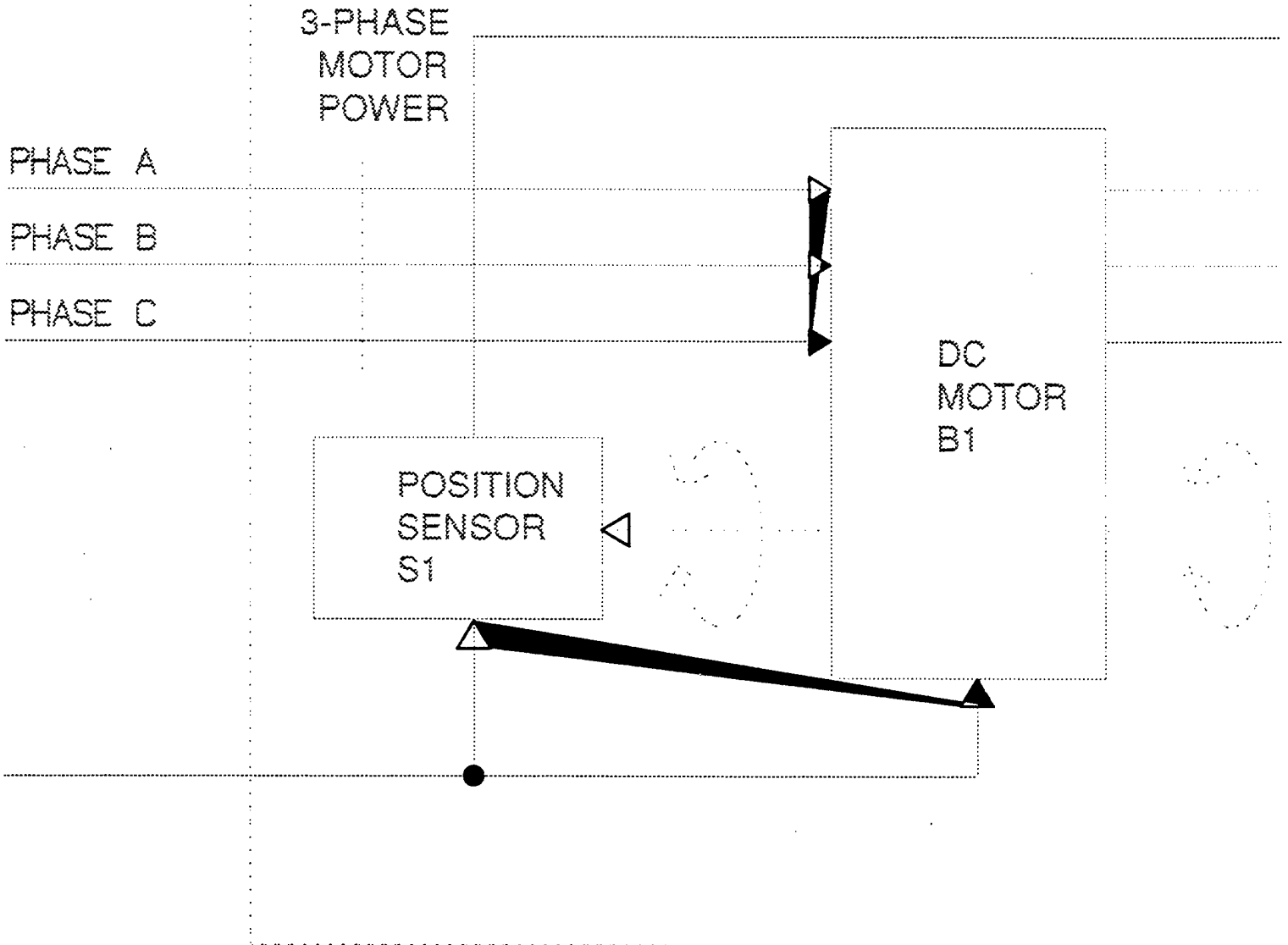

10.1.6 Output iges2draw/IslandDraw

10.1.6.1 Normal Translation

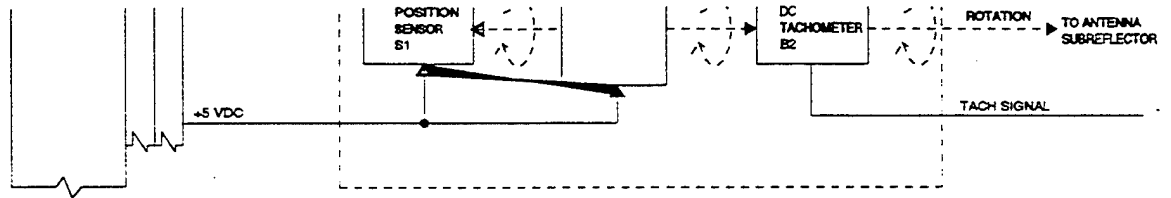

10.1.6.2 Bounded Data Translation

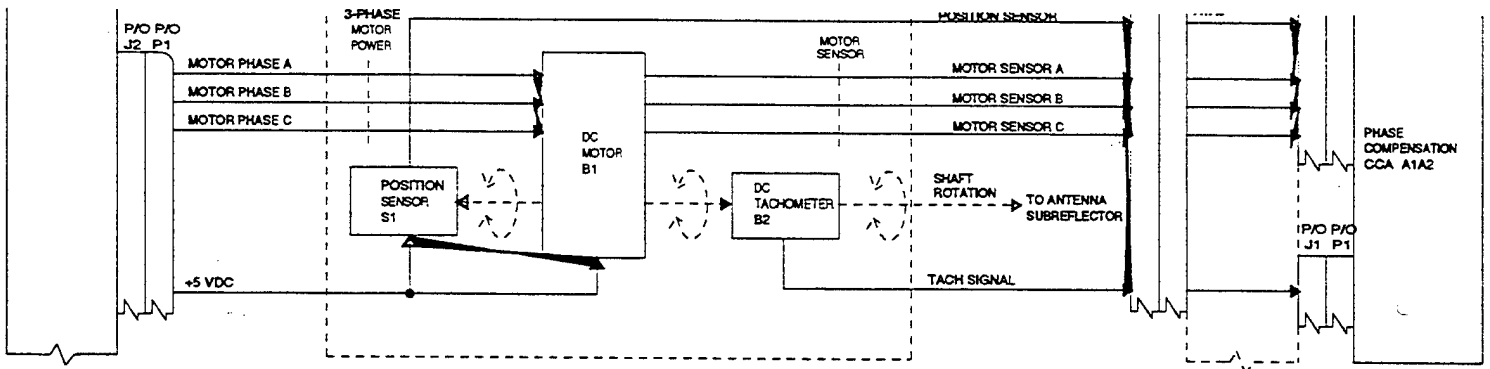

I2D/D
Q020
Bound Data

M103V

11. Appendix C - Detailed SGML Analysis

11.1 Parser Log

11.1.1 DTD Log File

SGML Document Type Definition Parser
An SGML System Conforming to
International Standard ISO 8879
Standard Generalized Markup Language

Log file: '9438.LOG'
SDO File: 'ctndocl.sdo'
Namecase General is yes.
Namecase Entity is no.
Parsing DTD file: '9438.dtd'
Parsing DOCTYPE TM

This DTD conforms to the ISO 8879 standard

DTO file '9438.DTO' created

closing statistics:
Capacity points: 27352
Bytes of DTO file string space: 7759
SGML descriptor blocks: 3348

Document Type Definition is compliant and parsed normally.

Program status code: 0.

11.2 Exoterica XGMLNormalizer Parser

No reported errors or warnings.

11.3 Exoterica validator Parser

```
<!-- **Warning** in "i:\94038\BSPEC.DTD" (entity "%BSPEC"), line 1,
      used in "\xgml\9438.dtd", line 1:
      An element with mixed content should permit data characters ("#PCDATA")
      everywhere.
      The element being declared is "WARNING".
      <!ELEMENT warning - - (title?, (%txt; | para | list)+) >
<!ATTLIST (warni
                                                    /\ -->
<!-- 1 warning reported. -->
```

11.4 Sema Mark-it Log

No reported errors or warnings.

11.5 Public Domain sgmls Log

```
sgmls: In file included at 9438.dtd, line 64:
      SGML error at BSPEC.DTD, line 67 at "<":
      Incorrect character in markup; markup terminated
sgmls: In file included at 9438.dtd, line 64:
      SGML error at BSPEC.DTD, line 67 in declaration parameter 4:
      MDC delimiter (>) expected; following text may be misinterpreted
sgmls: In file included at 9438.dtd, line 64:
      SGML error at BSPEC.DTD, line 68 at "]"":
      Incorrect character in markup; markup terminated
sgmls: In file included at 9438.dtd, line 64:
      SGML error at BSPEC.DTD, line 68 in declaration parameter 4:
      MDC delimiter (>) expected; following text may be misinterpreted
sgmls: SGML error at i:\94038\t025.txt, line 119 at "":
      BOARDNO = "ESDCAU" ENTITY attribute not general entity; may affect
      processing Element structure: TM FRONT INTRO P0 P1 FIGURE
```

<<<< PART OF LOG FILE REMOVED HERE >>>>

TOTALCAP 62371
ENTCAP 11392
ENTCHCAP 3493
ELEMCA 3840
GRPCAP 23072
EXGRPCAP 896
EXNMCA 3872
ATTCAP 5984
ATTCHCAP 315
AVGRPCAP 9248
NOTCAP 96
NOTCHCAP 163
IDCAP 0
IDREFCAP 0
MAPCAP 0
LKSETCAP 0
LKNMCA 0

12. Appendix E - Detailed CGM Analysis

12.1 File D001C005

12.1.1 Parser Log MetaCheck

MetaCheck Version 2.10 -- CGM/MIL-D-28003 Conformance Analyzer
Copyright 1988-93 CGM Technology Software
Execution Date: 05/06/94 Time: 14:29:25

Metafile Examined : i:\94038\c005.cgm

Pictures Examined : All

Elements Examined : All

Bytes Examined : All

=====
===== Trace Report =====

Tracing not selected.

=====
===== CGM Conformance Violation Report =====

No Errors Detected

=====
===== CALS CGM Profile (MIL-D-28003) Report =====

No profile discrepancies detected.

=====
===== Conformance Summary Report =====

MetaCheck Version 2.10 -- CGM/MIL-D-28003 Conformance Analyzer
Copyright 1988-93 CGM Technology Software
Execution Date: 05/06/94 Time: 14:29:33

Name of CGM under test: i:\94038\c005.cgm

Encoding : Binary

Pictures Examined : All

Elements Examined : All

Bytes Examined : All

BEGIN METAFILE string : >m1008<

METAFILE DESCRIPTION : >AUTO-TROL/REL-1.0 MIL-D-28003/BASIC-<
>1<

Picture 1 starts at octet offset 122: >m1008<

Conformance Summary : This file conforms to the CGM specification.
This file meets the CALS CGM Profile (MIL-D-28003).

Summary of Testing Performed and Errors Found:

1 Pictures Tested
506 Elements Tested
46408 Octets Tested

```
=====
|   No Errors Were Detected   |
=====
```

===== End of Conformance Report =====

12.1.2 validcgm Log

Analysis for file c005.cgm using table table

(0, 1) occurred 1 time
(0, 2) occurred 1 time
(0, 3) occurred 1 time
(0, 4) occurred 1 time
(0, 5) occurred 1 time
(1, 1) occurred 1 time
(1, 2) occurred 1 time
(1, 7) occurred 1 time
(1, 8) occurred 1 time
(1, 9) occurred 1 time
(1, 11) occurred 1 time
(1, 13) occurred 1 time
(2, 1) occurred 1 time
(2, 3) occurred 1 time
(2, 4) occurred 1 time
(2, 5) occurred 1 time
(2, 6) occurred 1 time
(2, 7) occurred 1 time
(4, 1) occurred 405 times
(4, 4) occurred 35 times
(4, 17) occurred 3 times
(4, 18) occurred 4 times
(5, 3) occurred 4 times
(5, 4) occurred 4 times
(5, 10) occurred 1 time
(5, 14) occurred 1 time
(5, 15) occurred 5 times
(5, 16) occurred 1 time
(5, 18) occurred 1 time
(5, 22) occurred 1 time
(5, 23) occurred 1 time
(5, 28) occurred 1 time
(5, 30) occurred 1 time
(5, 34) occurred 20 times

12.1.3 Output CADLeaf

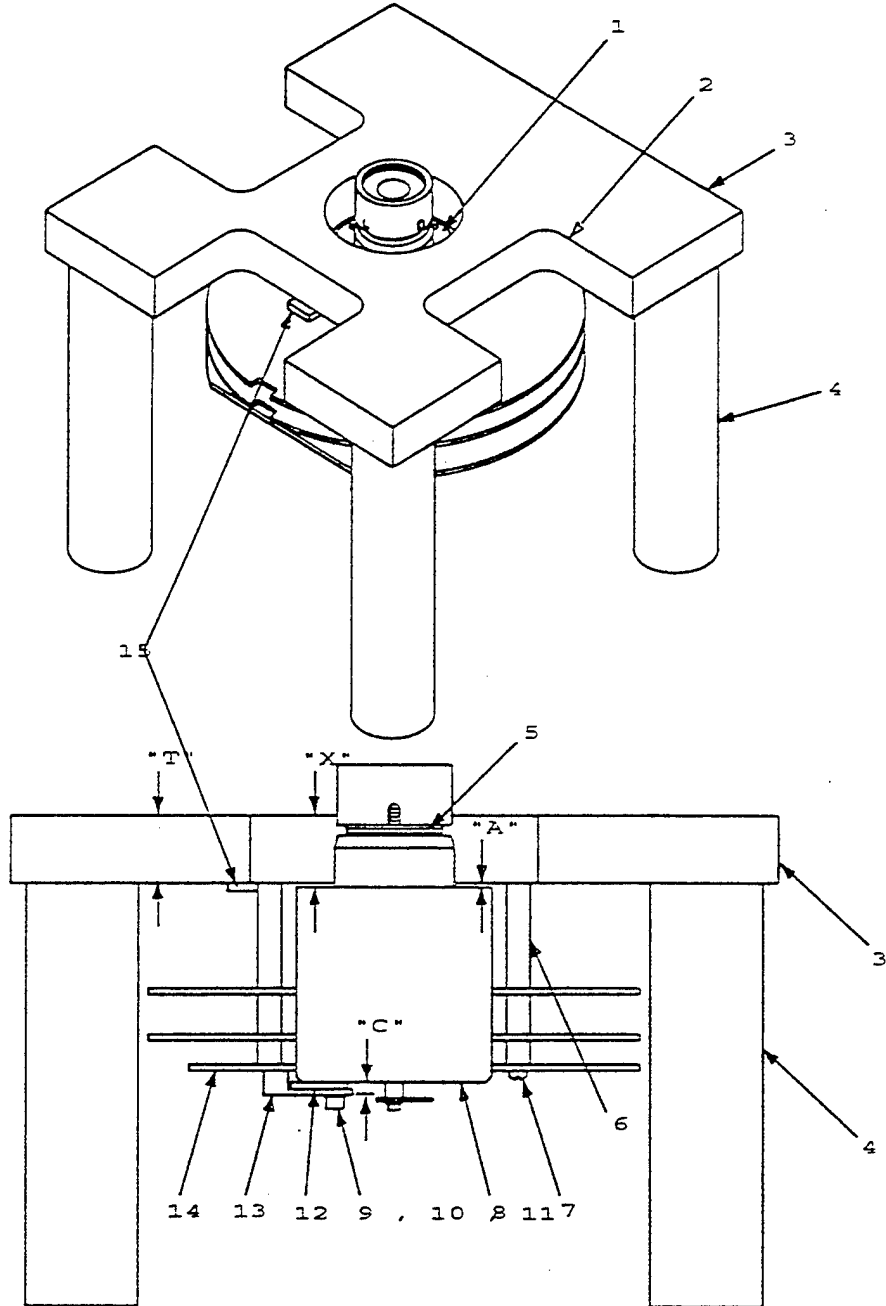

M10.06

LEGEND:

- | | | | | |
|---|------------------------------------|----|----------------------|-------------------|
| 1 | MOTOR HOUSING | 6 | STANDOFF (4 EA) | FLATWASHER (6 EA) |
| 2 | MEASUREMENT ACCESS SCREW (4 EA) | 12 | LAMINATED SHIM | |
| 3 | HOLD / INDICATING FIXTURE ASSEMBLY | 14 | ELECTRONICS ASSEMBLY | |
| 4 | POST (4 EA) | 9 | SCREW (3 EA) | 14 |
| 5 | DRIVE SHAFT | 10 | LOCKWASHER (3 EA) | 11 |
| | | | | 13 |

12.1.4 Output CALSView

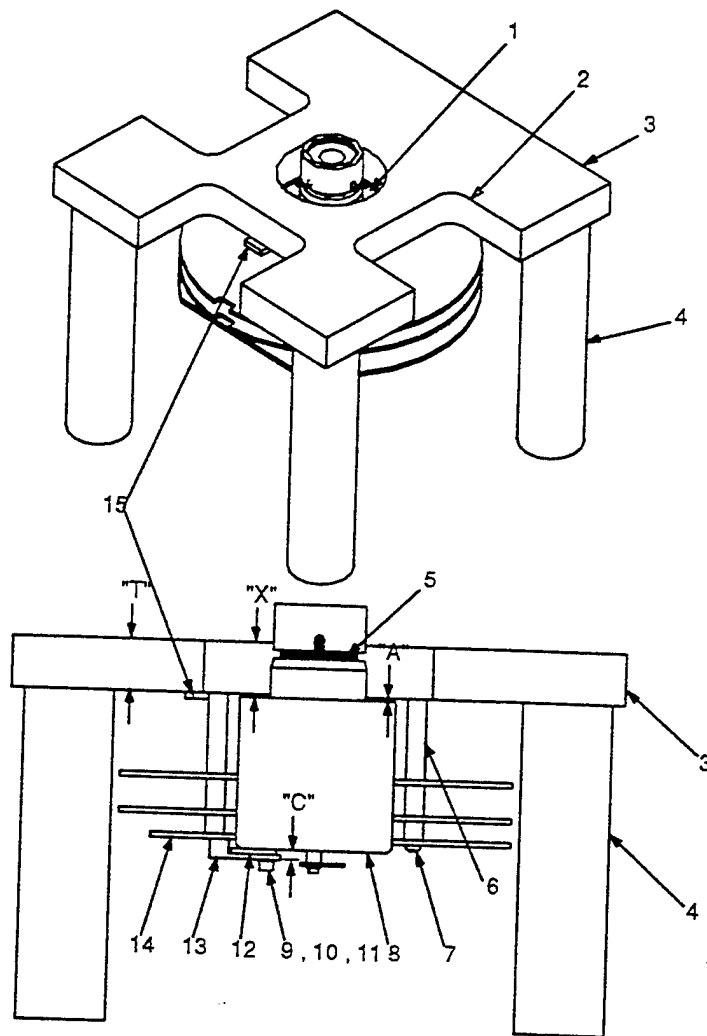

- LEGEND:
- | | | |
|-----------------------------------|----------------------|-------------------------|
| 1 MOTOR HOUSING | 6 STANDOFF (4 EA) | 11 FLATWASHER (6 EA) |
| 2 MEASUREMENT ACCESS SCREW (4 EA) | 7 SCREW (4 EA) | 12 LAMINATED SHIM |
| 3 HOLD / INDICATING FIXTURE | 8 MOTOR ASSEMBLY | 13 MOTOR TAB |
| 4 POST (4 EA) | 9 SCREW (3 EA) | 14 ELECTRONICS ASSEMBLY |
| 5 DRIVE SHAFT | 10 LOCKWASHER (3 EA) | 15 FIXTURE TAB |

12.1.5 Output cgm2draw/IslandDraw

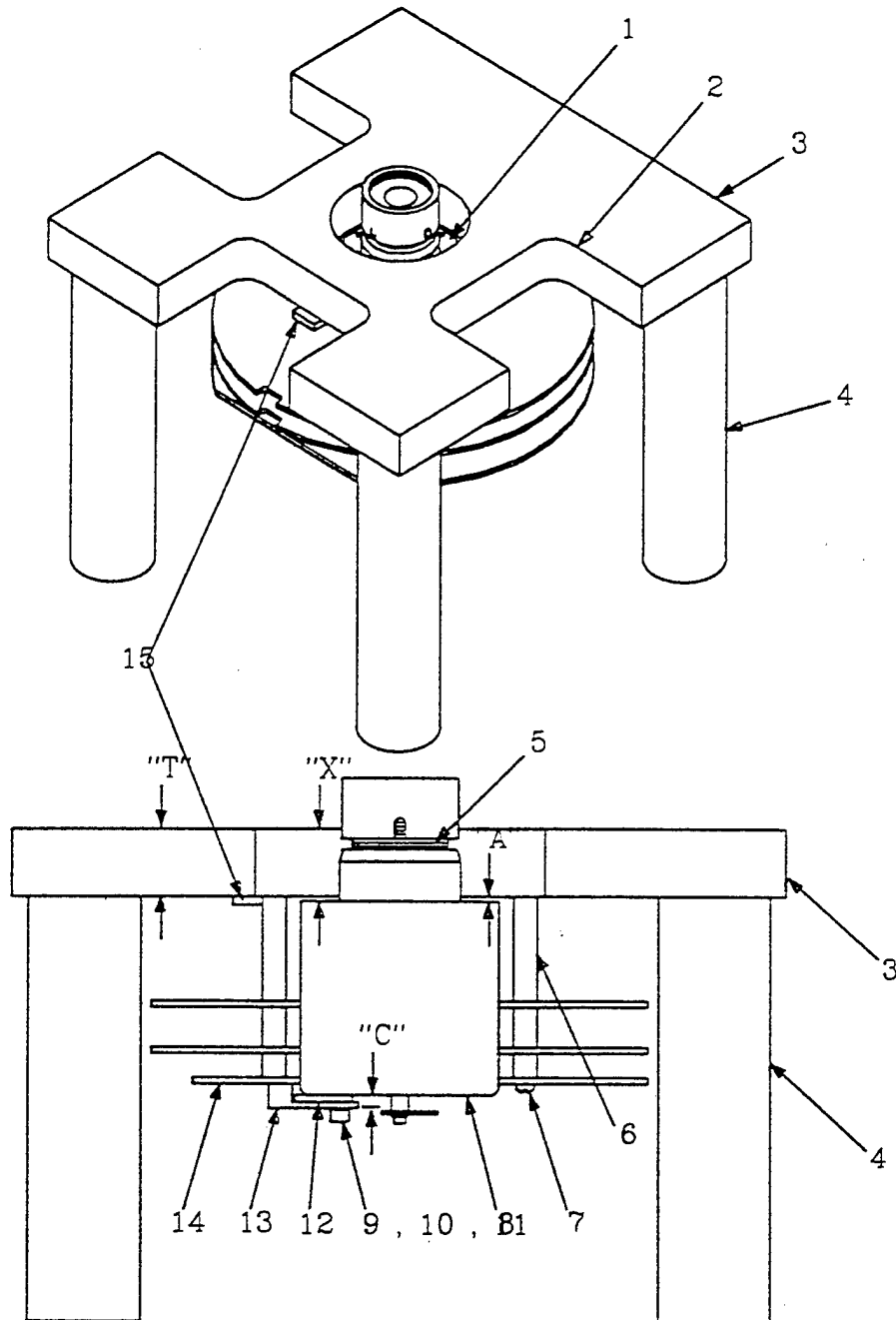

M10.06

LEGEND:

- | | | | | | |
|---|---------------------------------|----|-------------------|----|----------------------|
| 1 | MOTOR HOUSING | 6 | STANDOFF (4 EA) | 11 | FLATWASHER (6 EA) |
| 2 | MEASUREMENT ACCESS SCREW (4 EA) | 12 | LAMINATED SHIM | 13 | MOTOR TAB |
| 3 | HOLD / INDICATING POST (4 EA) | 8 | MOTOR ASSEMBLY | 14 | ELECTRONICS ASSEMBLY |
| 4 | POST (4 EA) | 9 | SCREW (3 EA) | 15 | FIXTURE TAB |
| 5 | DRIVE SHAFT | 10 | LOCKWASHER (3 EA) | | |

12.1.6 Output Designer

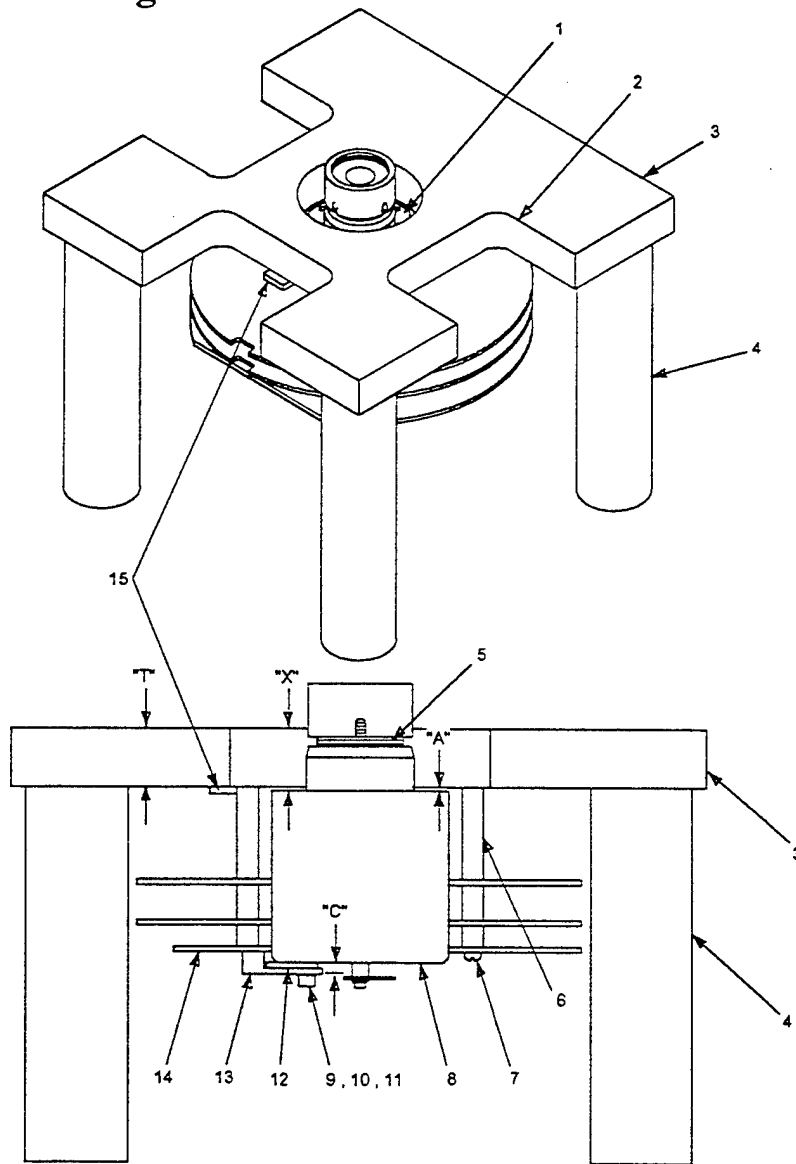

MIC.08

LEGEND:

- | | | |
|-----------------------------|----------------------|-------------------------|
| 1 MOTOR HOUSING | 6 STANDOFF (4 EA) | 11 FLATWASHER (6 EA) |
| 2 MEASUREMENT ACCESS | 7 SCREW (4 EA) | 12 LAMINATED SHIM |
| 3 HOLD / INDICATING FIXTURE | 8 MOTOR ASSEMBLY | 13 MOTOR TAB |
| 4 POST (4 EA) | 9 SCREW (3 EA) | 14 ELECTRONICS ASSEMBLY |
| 5 DRIVE SHAFT | 10 LOCKWASHER (3 EA) | 15 FIXTURE TAB |

12.1.7 Output Freelance

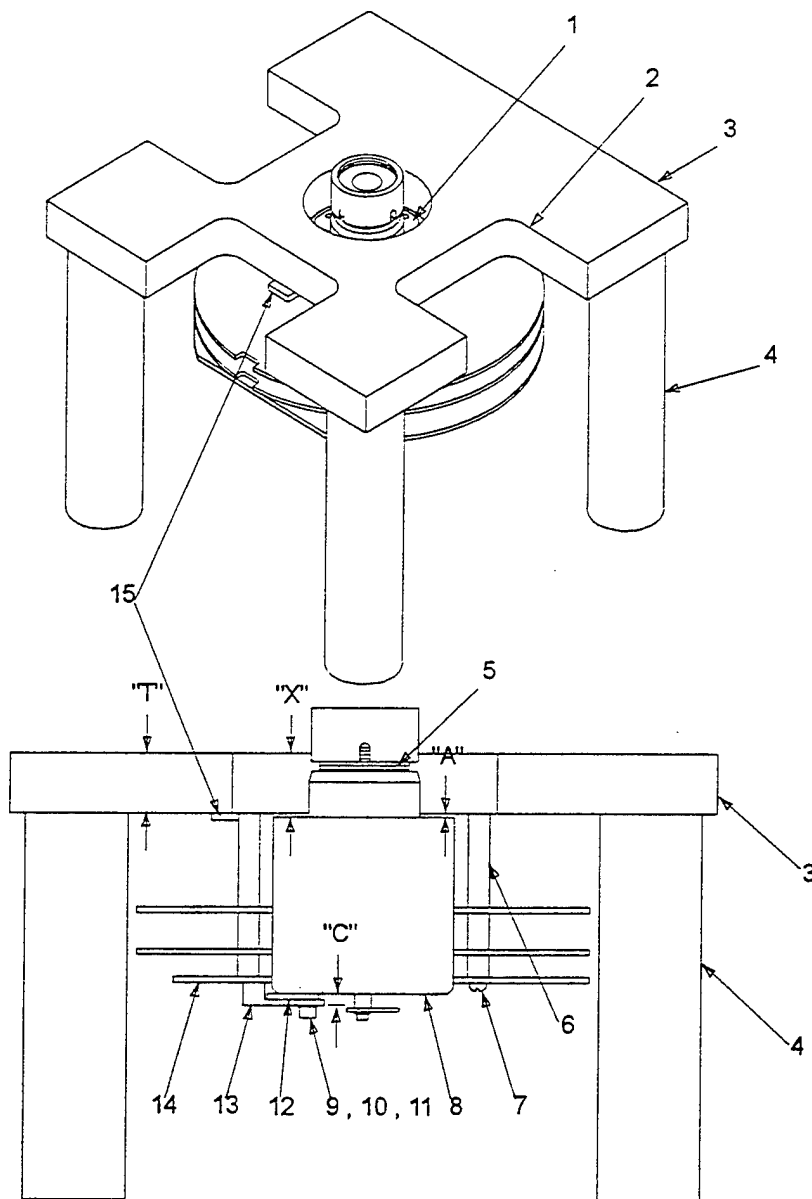

LEGEND:

- | | | |
|-----------------------------|----------------------|-------------------------|
| 1 MOTOR HOUSING | 6 STANDOFF (4 EA) | 11 FLATWASHER (6 EA) |
| 2 MEASUREMENT ACCESS | 7 SCREW (4 EA) | 12 LAMINATED SHIM |
| 3 HOLD / INDICATING FIXTURE | 8 SCREW (3 EA) | 13 MOTOR ASSEMBLY |
| 4 POST (4 EA) | 9 SCREW (3 EA) | 14 ELECTRONICS ASSEMBLY |
| 5 DRIVE SHAFT | 10 LOCKWASHER (3 EA) | 15 FIXTURE TAB |

12.1.8 Output Harvard Graphics

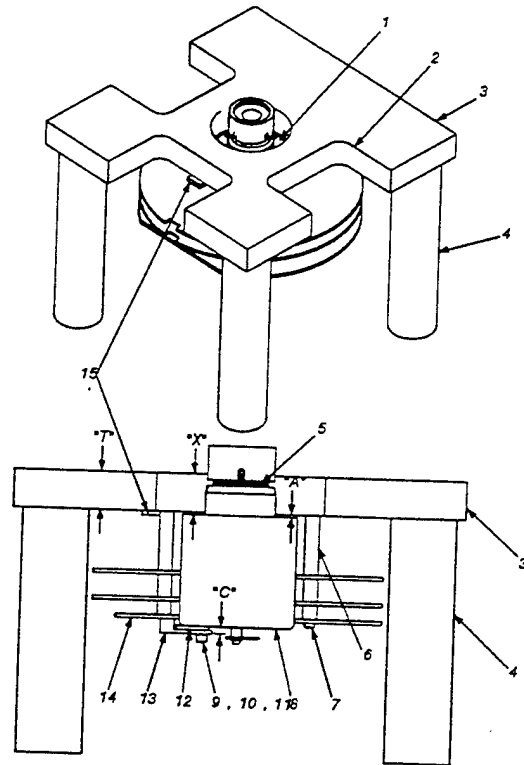

- LEGEND:
- | | | |
|--|----------------------|-------------------------|
| 1 MOTOR HOUSING | 6 STANDOFF (4 EA) | 11 FLATWASHER (6 EA) |
| 2 MEASUREMENT ACCESS SCREW (4 EA) | 7 SCREW (3 EA) | 12 LAMINATED SHIM |
| 3 HOLD / INDICATING FIXTURE MOTOR ASSEMBLY | 8 LOCKWASHER (3 EA) | 13 MOTOR TAB |
| 4 POST (4 EA) | 9 SCREW (3 EA) | 14 ELECTRONICS ASSEMBLY |
| 5 DRIVE SHAFT | 10 LOCKWASHER (3 EA) | 15 FIXTURE TAB |

12.1.9 Output IslandDraw v4.0

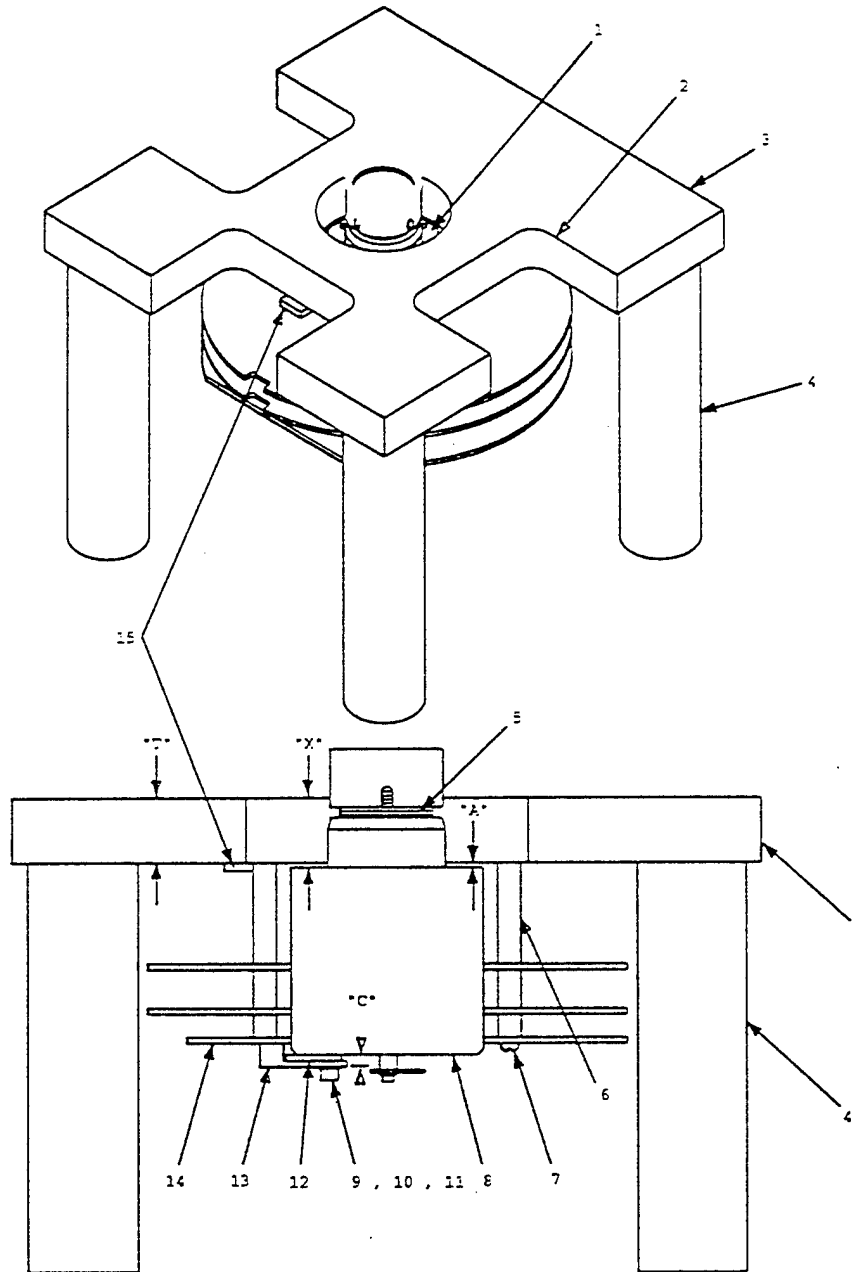

M10.08

LEGEND:

- | | | |
|-----------------------------|----------------------|-------------------------|
| 1 MOTOR HOUSING | 6 STANDOFF (4 EA) | 11 FLATWASHER (6 EA) |
| 2 MEASUREMENT ACCESS | 7 SCREW (4 EA) | 12 LAMINATED SHIM |
| 3 HOLD / INDICATING FIXTURE | 8 MOTOR ASSEMBLY | 13 MOTOR TAB |
| 4 POST (4 EA) | 9 SCREW (3 EA) | 14 ELECTRONICS ASSEMBLY |
| 5 DRIVE SHAFT | 10 LOCKWASHER (2 EA) | 15 FIXTURE TAB |

12.1.10 Output X-Change

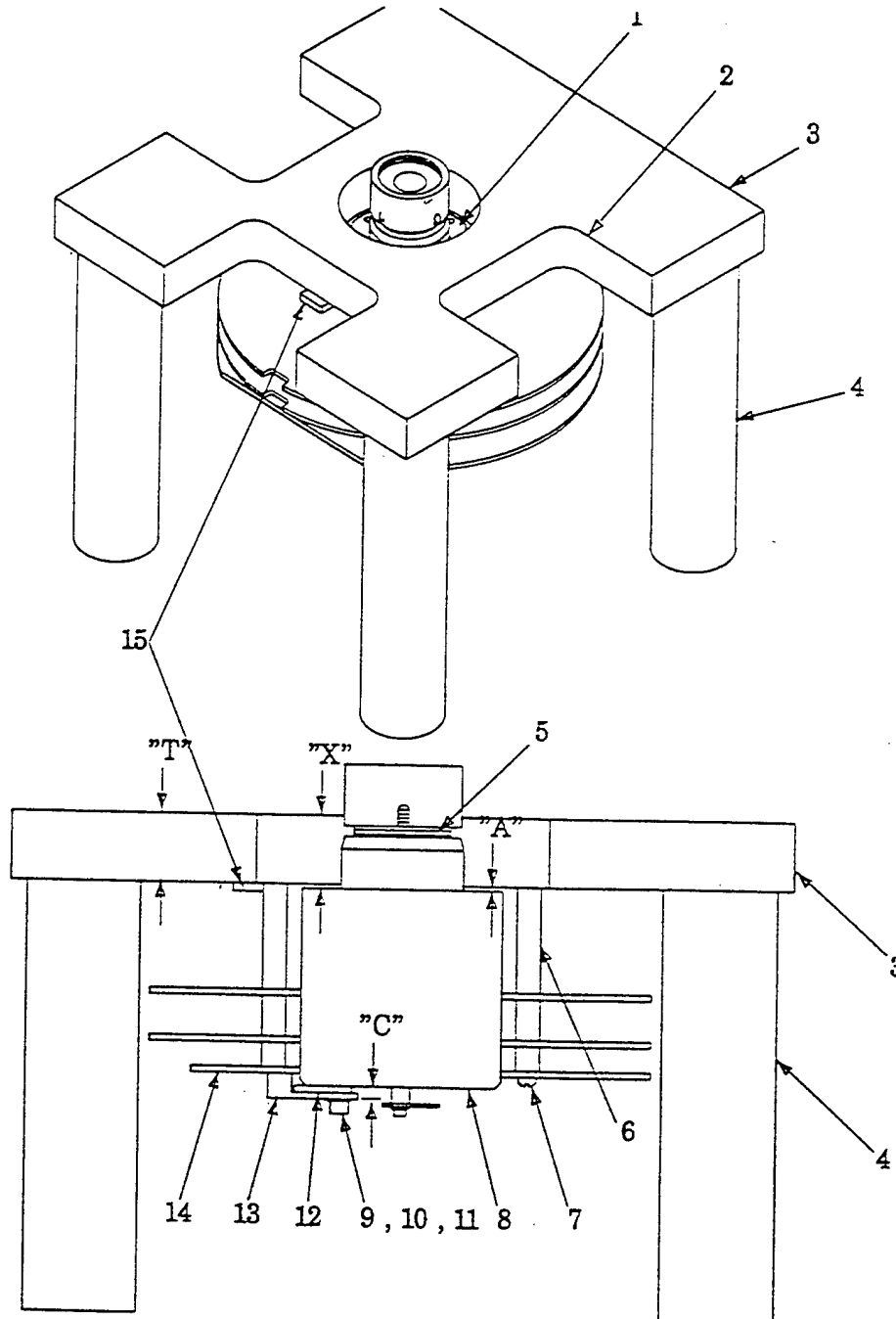

M10.08

LEGEND:

- | | | |
|-----------------------------------|----------------------|-------------------------|
| 1 MOTOR HOUSING | 6 STANDOFF (4 EA) | 11 FLATWASHER (6 EA) |
| 2 MEASUREMENT ACCESS SCREW (4 EA) | 7 MOTOR ASSEMBLY | 12 LAMINATED SHIM |
| 3 HOLD / INDICATING FIXTURE | 8 MOTOR TAB | 13 MOTOR TAB |
| 4 POST (4 EA) | 9 SCREW (3 EA) | 14 ELECTRONICS ASSEMBLY |
| 5 DRIVE SHAFT | 10 LOCKWASHER (3 EA) | 15 FUTURE TAB |

12.1.11 Output Ventura Publisher

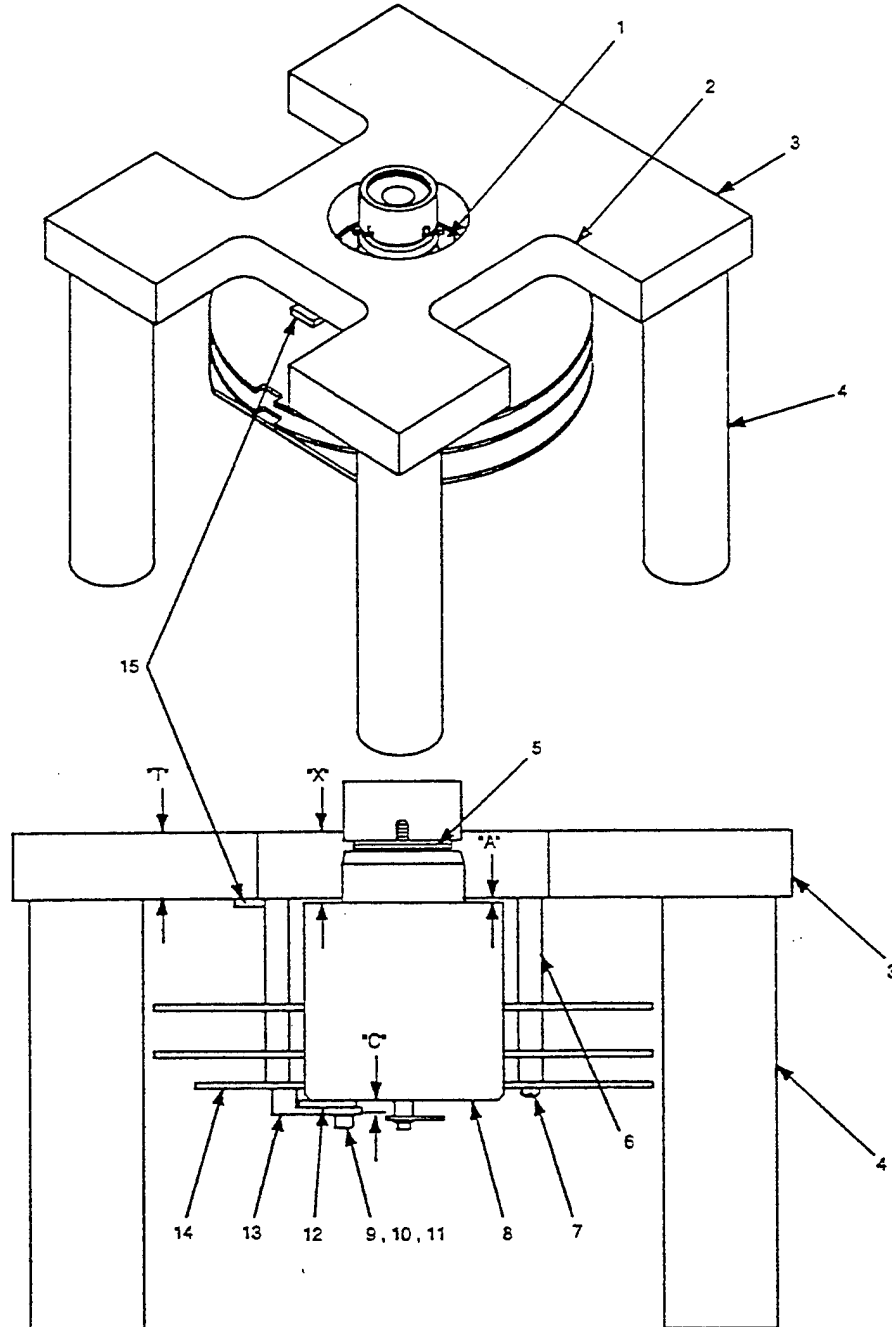

M10.02

LEGEND:

- | | | |
|-----------------------------|----------------------|-------------------------|
| 1 MOTOR HOUSING | 6 STANDOFF (4 EA) | 11 FLATWASHER (6 EA) |
| 2 MEASUREMENT ACCESS | 7 SCREW (4 EA) | 12 LAMINATED SHIM |
| 3 HOLD / INDICATING FIXTURE | 8 MOTOR ASSEMBLY | 13 MOTOR TAB |
| 4 POST (4 EA) | 9 SCREW (3 EA) | 14 ELECTRONICS ASSEMBLY |
| 5 DRIVE SHAFT | 10 LOCKWASHER (3 EA) | 15 FIXTURE TAB |