



AFCTN Test Report 94-100

AFCTB-ID
94-071



Technical Publication Transfer Using:

O'Neil & Associates' Data Supporting:



**ESC/MSL MILSTAR Program
T O 31R2-2FRC181-34**

(Contract #F19628-89-C-0131)

19960822 068

**MIL-STD-1840A
MIL-D-28000A (IGES)
MIL-M-28001B (SGML)
MIL-R-28002A (Raster)
MIL-D-28003 (CGM)**

Quick Short Test Report

16 June 1994



*Prepared for
Electronic Systems Center
Air Force CALS Program Office
HQ ESC/AV-2
4027 Colonel Glenn Hwy Suite 300
Dayton OH 45431-1672*

DTIC QUALITY INSPECTED 3

DISTRIBUTION STATEMENT A

Approved for public release;
Distribution Unlimited

DISCLAIMER NOTICE

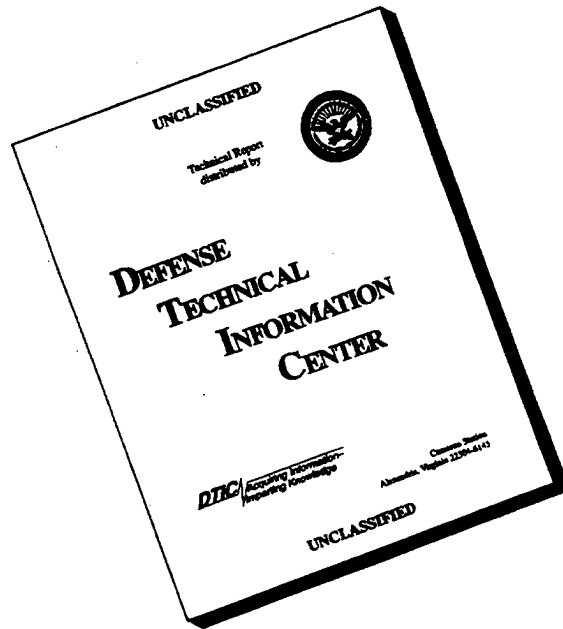

THIS DOCUMENT IS BEST QUALITY AVAILABLE. THE COPY FURNISHED TO DTIC CONTAINED A SIGNIFICANT NUMBER OF PAGES WHICH DO NOT REPRODUCE LEGIBLY.

Technical Publication Transfer Using:

O'Neil & Associates' Data

Supporting:

ESC/MSL's MILSTAR Program

T O 31R2-2FRC181-34

(Contract #F19628-89-C-0131)

MIL-STD-1840A

MIL-D-28000A (IGES)

MIL-M-28001B (SGML)

MIL-R-28002A (Raster)

Quick Short Test Report

16 June 1994

Prepared By

Air Force CALS Test Bed
Wright-Patterson AFB, OH 45433

AFCTB Contact

Gary Lammers
(513) 427-2295

AFCTN Contact

Mel Lammers
(513) 427-2295

DTIC QUALITY INSPECTED 3

DISCLAIMER

This document was prepared as an account of the work sponsored by the Air Force. Neither the United States Government, the Air Force, nor any of their employees makes any warranty, express or implied, or assumes any legal liability or responsibility for the accuracy, completeness, or usefulness of any information, apparatus, product, or process disclosed, nor represents that its use would not infringe on privately owned rights. Reference herein to any specific commercial products, process, or service by trade name, trademark, manufacturer, or otherwise, does not necessarily constitute or imply its endorsement, recommendation, or favoring by the United States Government or the Air Force. The views and opinions of authors expressed herein do not necessarily state or reflect those of the United States Government or the Air Force, and shall not be used for advertising or product endorsement purposes.

Available to the public from the
National Technical Information Service
U.S. Department of Commerce
5285 Port Royal Road
Springfield, VA 22161

This report and those involved in its preparation do not endorse any product, process, or company stated herein. Use of these means by anyone does not imply certification by the Air Force CALS Test Network (AFCTN).

Air Force CALS Test Bed

Notification of Test Results

16 June 1994

This notice documents the results of an Air Force CALS Test Bed (AFCTB) Quick Short Test Report (QSTR) evaluation of data submitted by:

O'Neil & Associates, Inc.

Identified as follows:

Title:	Technical Publication T O 31R2-2FRC181-34
Program:	MILSTAR
Program Office:	ESC/MSL
Contract No.:	F19628-89-C-0131
QSTR No.:	AFCTB-ID 94-071

Received on the following media: **9-Track Tape**

The results of the QSTR evaluation are as follows:

MIL-STD-1804A Standard	Pass
MIL-STD-1840A Media Format:	Pass
MIL-D-28000A IGES:	Pass
MIL-M-28001B SGML:	Pass
MIL-R-28002A Raster:	Pass
MIL-D-28003 CGM:	Pass

Formal results with associated disclaimer are documented and available from the AFCTB.

Air Force CALS Test Bed
HQ ESC/AV-2P
4027 Colonel Glenn Highway, Suite 300
Dayton, OH 45431-1672
Phone: 513-257-3085 FAX: 513-257-5881

Contents

1.	Introduction.....	1
1.1.	Background.....	1
1.2.	Purpose.....	2
2.	Test Parameters.....	3
3.	1840A Analysis.....	6
3.1.	External Packaging.....	6
3.2.	Transmission Envelope.....	6
3.2.1.	Tape Formats.....	6
3.2.2.	Declaration and Header Fields.....	7
4.	IGES Analysis.....	7
5.	SGML Analysis.....	9
6.	Raster Analysis.....	10
7.	CGM Analysis.....	11
8.	Conclusions and Recommendations.....	12
9.	Appendix A - Tapetool Report Logs.....	13
9.1.	Tape Catalog.....	13
9.2.	Tape Evaluation Log.....	14
9.3.	Tape File Set Validation Log.....	15
9.4.	Other Tape Reading Logs.....	19
10.	Appendix B - Detailed IGES Analysis.....	20
10.1.	File D001Q006.....	20
10.1.1.	Parser/Verifier Log.....	20
10.1.2.	Parser Log - IGESWorks.....	26

10.1.3.	Output Cadkey v6.0 - Detail.....	29
10.1.4.	Output CADLeaf - Detail.....	30
10.1.5.	Output IslandDraw.....	31
10.1.6.	Output IGESView.....	32
10.1.7.	Output IGESWorks - Detail.....	33
10.1.8.	Output Preview.....	34
10.2.	File D001Q020.....	35
10.2.1.	Parser/Verifer Log.....	35
10.2.2.	Output Cadkey v6.0 - Detail.....	40
10.2.3.	Output CADLeaf.....	41
10.2.4.	Output IslandDraw.....	42
10.2.5.	Output IGESView.....	43
10.2.6.	Output IGESWorks - Detail.....	44
10.2.7.	Output Preview - Detail.....	45
10.2.8.	Output X-Change.....	46
11.	Appendix C - Detailed SGML Analysis.....	47
11.1.	Exoterica Validator Parser.....	47
12.	Appendix D - Detailed Raster Analysis.....	48
12.1.	File D001R024.....	48
12.1.1.	Output CADleaf - As Received (W/B).....	48
12.1.2.	Output CADLeaf - Reversed (B/W).....	49

1. Introduction

1.1 Background

The Department of Defense (DoD) Air Force Continuous Acquisition and Life-cycle Support (CALs) Test Network (AFCTN) is conducting tests of the military standard for the Automated Interchange of Technical Information, MIL-STD-1840A, and its companion suite of military specifications. The AFCTN is a DoD sponsored confederation of voluntary participants from industry and government managed by the Electronic Systems Center (ESC).

The primary objective of the AFCTN is to evaluate the effectiveness of the CALs standards for technical data interchange and to demonstrate the technical capabilities and operational suitability of those standards. Two general categories of tests are performed to evaluate the standards; formal and informal.

Formal tests are large and comprehensive, which follow a written test plan, require specific authorization from the DoD, and may take months to prepare, execute, and report.

Informal tests are quick and short, used by the AFCTN technical staff, to broaden the testing base. They include representative samples of the many systems and applications used by AFCTN participants. They also allow the AFCTN staff to gain feedback from many industry and government interpretations of the standards, to increase the base of participation in the CALs initiative, and respond to the many requests for help that come from participants. Participants take part voluntarily, benefit by receiving an evaluation of their latest implementation (interpretation) of the standards, interact with the AFCTN technical staff, gain experience using the standards, and develop increased confidence in them. The results of informal tests are reported in Quick Short Test Reports (QSTRs) that briefly summarize the standard(s) tested, the hardware and software used, the nature of the test, and the results.

1.2 Purpose

The purpose of the informal test, reported in this QSTR, was to analyze O'Neil & Associates' interpretation and use of the CALS standards in transferring technical publication data. O'Neil used its CALS Technical Data Interchange System to produce data, in accordance with the standards, and delivered it to the AFCTN technical staff on a 9-track magnetic tape.

2. Test Parameters

Test Plan: AFCTB 94-071

Date of Evaluation: 16 June 1997

Evaluator: George Elwood
Air Force CALS Test Bed
DET 2 HQ ESC/AV-2P
4027 Colonel Glenn Hwy
Suite 300
Dayton OH 45431-1672

Data Originator: Larry C. McKinley
O'Neil & Associates, Inc.
425 North Findlay Street
Dayton OH 45404-2203
(513) 461-1852

Data Description: Technical Manual Test

- 1 Document Declaration file
- 4 Document Type Definitions (DTDs)
- 19 Initial Graphics Exchange Specification (IGES) files
- 1 Text/Standard Generalized Markup Language (SGML) file
- 2 Raster files

Data Source System:

1840

HARDWARE

386 PC

SOFTWARE

AFCTN Tapetool v1.2.10

IGES

HARDWARE

Xerox 7650 Pro Imager
Xerox 6085 Workstation

SOFTWARE

Xerox Expert Drafting v5.0
Conversion of IGES files v5.1

Text/SGML

HARDWARE

386 PC

SOFTWARE

WordPerfect Intellitag v1.2
Exoterica Validator v1.1

Raster

HARDWARE

Xerox 7650 Pro Imager
6085 Workstation

SOFTWARE

Xerox XTI v2.2
Xerox XPI Image Conversion 2.6

Evaluation Tools Used:

MIL-STD-1840A (TAPE)

SUN 3/280

AFCTN *Tapetool v1.2.10 UNIX*
XSoft *CAPS/CALS v40.4*

MIL-D-28000 (IGES)

HP 735

Carberry *CADLeaf Plus v3.1.2*
InterCAP *X-Change v7.82*
Island Software *IslandDraw v3.0*

SGI Indigo2

Cadkey *Cadkey v6.0*
IGES Data Analysis (IDA) *CALSVIEW*
International TechneGroup Incorporated
(ITI) *IGES/Works v2.0.0*

Sun SparcStation 2

Carberry *CADLeaf Plus v3.1*
IDA *Parser/Verifier v92*
IDA *IGESView v3.05*
ITI *IGES/Works v1.3*
Rosetta Technologies *Prepare*
Rosetta Technologies *Preview v3.2*

MIL-M-28001 (SGML)

PC 486/50

Exoterica *XGMLNormalizer v1.2e3.2*
Exoterica *Validator v2.0 ex1*
McAfee & McAdam *Sema Mark-it v2.3*
Public Domain *sgmls*

MIL-R-28002 (Raster)

HP 735

AFCTN *xrastb.hp*

InterCAP *X-Change v7.82*

SGI Indigo2

IDA *CALView*

SUN SparcStation 2

Carberry *CADLeaf Plus v3.1*

AFCTN *validg4*

AFCTN *xrastb.sun4*

IDA *IGESView v3.0*

PC 486

IDA *IGESView Windows*

Inset Systems *HiJaak Pro*

Expert Graphics *RxHighlight v1.0*

Standards

Tested:

MIL-STD-1840A

MIL-D-28000A

MIL-M-28001B

MIL-R-28002A

3. 1840A Analysis

3.1 External Packaging

The tape arrived at the Air Force CALS Test Bed (AFCTB) enclosed in a box in accordance with ASTM D 3951. The exterior of the box was marked with a magnetic tape warning label, as required by MIL-STD-1840A, para. 5.3.1.3.

The tape was enclosed in a barrier bag as required by MIL-STD-1840A, para. 5.3.1.2. Inspection of the tape reel showed the label indicating the recording density, as required by MIL-STD-1840A, para. 5.3.1. Enclosed in the box was a packing list showing all files recorded on the tape.

3.2 Transmission Envelope

The 9-track tape received by the AFCTB contained MIL-STD-1840A files. The files were named per the standard conventions.

3.2.1 Tape Formats

The tape was run through the AFCTN *Tapetool v1.2.10* utility. No errors were encountered while evaluating the contents of the tape labels.

The tape was read using XSoft's *CAPS read1840A* utility without any reported errors. However, this process resulted in the loss of three of the four DTDs. This occurred because the four DTDs had identical destination system document (dstdocid) record values and the *CAPS read1840A* utility renames the files using the dstdocid record values. (MIL-STD-1840A permits identical dstdocid values for multiple files; MIL-STD-1840B corrected this problem).

The physical structure of the tape meets the CALS MIL-STD-1840A requirements.

3.2.2 Declaration and Header Fields

No errors were reported in the Document Declaration file and data file headers. This portion of the tape meets the CALS MIL-STD-1840A requirements.

4. IGES Analysis

The tape contained 19 IGES files. These files were evaluated using IDA's *parser/verifier* set for CALS Class I. This utility reported all 19 files meet the specification defined in MIL-D-28000A. While no CALS errors were reported, all files had basic IGES errors and/or warnings. These deficiencies were disjointed line segments, or disjointed arcs. When viewed in a technical publication these deficiencies were not apparent; however, when these areas were examined in detail they could be seen. In some cases these disjointed lines were thickened to hide the gaps and overlapping arcs.

It was also noted that the basic leader line was thickened. This made the arrowhead look different than the rest of the lines. The log files from IDA's *parser/verifier* and ITI's *IGESWorks* for files D001Q006 and Q020 are included in Appendix B, Section 10.1.1 and 10.1.2 of this report.

Each file was viewed by at least one software application. The required basic conformance statement was found in the Start section of the files. Files Q006 and Q020 were selected for the detailed analysis provided below. File Q006 had one noted problem on all systems. Three line entities were placed off the image to the left. These entities were defined in DE 5, 7, and 9. This image would be usable after removal of the added lines.

The AFCTB has several tools for viewing IGES files. These tools are not used to generate a pass/fail but to report how commercially available software can handle the files. Many of these products are used in the development of technical publications and are good indicators of usability. The use of these products is not an endorsement nor an indication of CALS capability. All operations were performed using the default settings.

The selected files were translated using Cadkey's **ig2c** utility. File Q006 had reported errors. The message was "entity types do not match @ parameter index xxxx" (3096 was one parameter reported). Found entity type 102 expected entity type 106. When this was checked the parameter and directory entities were correct. When displayed and printed the images appeared to be complete. Part of the log file and the IGES file are included in Appendix B of this report, detailing the errors reported.

The files were converted using a utility available within the AFCTB, with no reported errors. The resulting files were read into Island Software's **IslandDraw**, displayed and printed without a reported error. File Q006 displayed in the lower left corner of the screen. This is due to the origin point of the file located at a negative coordinate. Using an undocumented function of the utilities translator, the image was displayed correctly. The added heavy leader lines and arrowheads did not display as a sharp point.

The files were read using Carberry's **CADLeaf** software without a reported error. When displayed, the added entities, circles, arrowheads and arcs, were very noticeable. Note the detailed output in Appendix B of this report. File Q006 displayed in the lower left corner of the screen.

The files were read and displayed using IDA's **CALSVIEW** without a reported error. Text numbers and lines appeared to be thicker than normal.

The files were read and displayed using IDA's **IGESVIEW** and **IGESVIEW for Windows** without a reported error. All text appeared to be heavier than the rest of the image.

The files were read into ITI's **IGESWORKS** without a reported error. The connect points and arrowheads created using the 230 entity were missing.

The files were read and displayed using InterCAPS's **XChange**. No errors were noted.

The IGES files were converted using Rosetta Technologies' **Prepave** with reported errors. The errors were unsupported entities (230). The resulting files were read into Rosetta Technologies' **Preview**, displayed and printed. No errors were noted.

The IGES files meet the CALS MIL-D-28000A specification. However, the use of entity 230, to create the arrowheads and connect points, caused some systems to display unusable files. The reported IGES warnings were not critical for technical publication applications.

5. SGML Analysis

The tape contained one text and four DTD files. The basic DTD contained the graphic references and pointed to the basic ATOS DTD, which was named BSPEC. The BSPEC DTD pointed to two other subset DTDs; CALSFIGS (figure unique tags) and CALSTABS (table unique tags).

```
BASIC (G003) ---> BSPEC (G004)
                   |> CALSTABS (G002)
                   |> CALSFIGS (G001)
```

The AFCTB has several parsers available for evaluating submitted DTD and text files. These tools are not used to generate a pass/fail but to report how commercially available software can handle the files. These products are used in the development of technical publications and are good indicators of usability. The use of these products is not an endorsement nor an indication of CALS capability. All operations were performed using the default settings unless specified in the report. Changes to DTD or text files required by each system are not documented in the report.

The text and DTD files were evaluated using Exoterica's **Validator ex1** parser. One warning, a mixed content model, was issued for the DTD. No errors were noted in the text file.

```
<!-- **Warning** in "i:\94071\BSPEC.DTD" (entity "%BSPEC"), line 342,
      used in "\xgml\9471.dtd", line 165:
      An element with mixed content should permit data characters ("#PCDATA")
      everywhere.
      The element being declared is "WARNING".
      <!ELEMENT warning - - (title?, (%txt; | para | list)+) >
      /\
-->
```

The text and DTD files were tested using Exoterica's **XGML-Normalizer** parser. No errors in the DTD or text files were reported.

The text and DTD files were evaluated using the Public Domain **sgmls** parser. No errors were issued by this program for the DTD or text files.

The SGML file meets the CALS MIL-M-28001B specification.

6. Raster Analysis

The tape contained two Raster files. Both files were evaluated using the AFCTN **validg4** utility. This program reported both files meet the CALS MIL-R-28002A specification.

The files were read into the AFCTN **xrastb.sun4** viewing utility. It was noted that the first image was white on black. This made viewing difficult. For technical publications graphic images are normally black on white.

The AFCTB has several tools for viewing Raster files. These tools are not used to generate a pass/fail but to report how commercially available software can handle the files. Many of these products are used in the development of technical publications and are good indicators of usability. The use of these products is not an endorsement nor an indication of CALS capability. All operations were performed using the default settings.

The Raster files were read into Carberry's **CADLeaf** software and displayed without a reported error. File R024 was printed in both white on black and black on white to show the difference.

The files were read using IDA's **CALSVIEW** and displayed without a reported error.

The files were read and displayed using IDA's **IGESVIEW** and **IGESVIEW for Windows** without a reported error.

The files were read and displayed using Inset Systems' **HiJaak for Windows** without a reported error.

The files were read and displayed using InterCAP's **X-Change** without a reported error.

The Raster files were converted using Rosetta Technologies' **Prepare** without a reported error. The resulting files were read into Rosetta Technologies' **Preview** and displayed.

The Raster files were imported into Expert Graphics' **Rx-Highlight** and displayed without a reported error.

The Raster files meet the CALS MIL-R-28002A specification.

7. CGM Analysis

No Computer Graphic Metafile (CGM) files were included in this evaluation.

8. Conclusions and Recommendations

The physical structure of the tape had no reported errors or warnings. The CALS headers were also correct. This portion of the tape meets the requirements defined in MIL-STD-1840A.

The IGES files had no reported CALS errors. All files reported basic IGES errors and/or warnings. These errors are not critical for files used in technical publications. The IGES files meet the CALS MIL-D-28000A specification.

The SGML files meet the CALS MIL-M-28001B specification.

The Raster files meet the CALS MIL-R-28002A specification.

The tape submitted by O'Neil & Associates, Inc. meets the CALS MIL-STD-1840A requirements.

9. Appendix A - Tapetool Report Logs

9.1 Tape Catalog

CALS Test Network Catalog Evaluation - Version 1.2; Release 10 (C)

Standards referenced:

- MIL-STD-1840A (1987) - Automated Interchange of Technical Information
- ANSI X3.27 (1987) - File Structure and labeling of Magnetic Tapes
for Information Interchange
- ANSI X3.4 (1986) - Coded Character Sets - 7 Bit ASCII

Wed Jun 15 12:04:36 1994

MIL-STD-1840A File Catalog

File Set Directory: /cals/u1210/Set074

Page: 1

File Name	File Type	Record Format/ Length	Block Length/Total	Selected/ Extracted
D001	Document Declaration	D/00260	02048/000001	Extracted
D001G001	DTD	D/00260	02048/000002	Extracted
D001G002	DTD	D/00260	02048/000002	Extracted
D001G003	DTD	D/00260	02048/000002	Extracted
D001G004	DTD	D/00260	02048/000008	Extracted
D001Q005	IGES	F/00080	02000/000258	Extracted

<<<< PART OF LOG FILE REMOVED HERE >>>>

D001Q023	IGES	F/00080	02000/000102	Extracted
D001R024	Raster	F/00128	02048/000025	Extracted
D001R025	Raster	F/00128	02048/000022	Extracted
D001T026	Text	D/00260	02048/000099	Extracted

Catalog Process terminated normally.

9.2 Tape Evaluation Log

CALS Test Network Tape Evaluation - Version 1.2; Release 10 (C)

Standards referenced:

ANSI X3.27 (1987) - File Structure and labeling of Magnetic Tapes
for Information Interchange

ANSI X3.4 (1986) - Coded Character Sets - 7 Bit ASCII

Wed Jun 15 12:00:20 1994

ANSI Tape Import Log

Allocating tape drive /dev/rmt0...
/dev/rmt0 allocated.

VOL1ONA001

4

Label Identifier: VOL1
Volume Identifier: ONA001
Volume Accessibility:
Owner Identifier:
Label Standard Version: 4

HDR1D001 ONA00100010001000000 94165 00000 000000

Label Identifier: HDR1
File Identifier: D001
File Set Identifier: ONA001
File Section Number: 0001
File Sequence Number: 0001
Generation Number: 0000
Generation Version Number: 00
Creation Date: 94165
Expiration Date: 00000
File Accessibility:
Block Count: 000000
Implementation Identifier:

HDR2D0204800260

00

<<<<< PART OF LOG FILE REMOVED HERE >>>>>

***** Tape Mark *****

End of Volume ONA001 #####
End Of Tape File Set

Deallocating /dev/rmt0...
Tape Import Process terminated normally.

9.3 Tape File Set Validation Log

CALS Test Network File Set Evaluation - Version 1.2; Release 10 (C)

Standards referenced:

MIL-STD-1840A (1987) - Automated Interchange of Technical Information

Wed Jun 15 12:04:37 1994

MIL-STD-1840A File Set Evaluation Log

File Set: Set074

Found file: D001

Extracting Document Declaration Header Records...

Evaluating Document Declaration Header Records...

srcsys: O'Neil & Assoc. CAGE 83007

srcdocid: TO_31R2-2FRC181-34

srcrelid: NONE

chglvl: ORIGINAL

dteisu: 19940609

dstsys: RAYTHEON CAGE 49956

dstdocid: TO_31R2-2FRC181-34

dstrelid: NONE

dtetrn: 19940614

dlvacc: NONE

filcnt: G4,Q19,R2,T1

ttlcls: UNCLASSIFIED

doccls: UNCLASSIFIED

doctyp: Technical Publication

doctl: NONE

Found file: D001G001

Extracting DTD Header Records...

Evaluating DTD Header Records...

srcdocid: TO_31R2-2FRC181-34

dstdocid: TO_31R2-2FRC181-34

notes: DTD, 3 of 4

Saving DTD Header File: D001G001_HDR

Saving DTD Data File: D001G001_DTD

Found file: D001G002
Extracting DTD Header Records...
Evaluating DTD Header Records...

srcdocid: TO_31R2-2FRC181-34
dstdocid: TO_31R2-2FRC181-34
notes: DTD, 4 of 4

Saving DTD Header File: D001G002_HDR
Saving DTD Data File: D001G002_DTD

Found file: D001G003
Extracting DTD Header Records...
Evaluating DTD Header Records...

srcdocid: TO_31R2-2FRC181-34
dstdocid: TO_31R2-2FRC181-34
notes: DTD, 1 of 4

Saving DTD Header File: D001G003_HDR
Saving DTD Data File: D001G003_DTD

Found file: D001G004
Extracting DTD Header Records...
Evaluating DTD Header Records...

srcdocid: TO_31R2-2FRC181-34
dstdocid: TO_31R2-2FRC181-34
notes: DTD, 2 of 4

Saving DTD Header File: D001G004_HDR
Saving DTD Data File: D001G004_DTD

Found file: D001Q005
Extracting IGES Header Records...
Evaluating IGES Header Records...

srcdocid: TO_31R2-2FRC181-34
dstdocid: TO_31R2-2FRC181-34
txtfilid: W
figid: 14 (2 OF 2)
srcgph: M03B78
doccls: UNCLASSIFIED
notes: NONE

Saving IGES Header File: D001Q005_HDR
Saving IGES Data File: D001Q005_IGS

Found file: D001Q006
Extracting IGES Header Records...
Evaluating IGES Header Records...

srcdocid: TO_31R2-2FRC181-34
dstdocid: TO_31R2-2FRC181-34
txtfilid: W
figid: 14 (1 OF 2)
srcgph: M03B79
doccls: UNCLASSIFIED
notes: NONE

Saving IGES Header File: D001Q006_HDR
Saving IGES Data File: D001Q006_IGS

<<<<< PART OF LOG FILE REMOVED HERE >>>>>

Found file: D001R024
Extracting Raster Header Records...
Evaluating Raster Header Records...

srcdocid: TO_31R2-2FRC181-34
dstdocid: TO_31R2-2FRC181-34
txtfilid: W
figid: HOW-TO-USE-2
srcgph: HOW2IPB2
doccls: UNCLASSIFIED
rtype: 1
rorient: 000,270
rpelcnt: 002097,002568
rdensty: 0300
notes: NONE

Saving Raster Header File: D001R024_HDR
Saving Raster Data File: D001R024_GR4

<<<<< PART OF LOG FILE REMOVED HERE >>>>>

Found file: D001T026
Extracting Text Header Records...
Evaluating Text Header Records...

srcdocid: TO_31R2-2FRC181-34
dstdocid: TO_31R2-2FRC181-34
txtfilid: W
doccls: UNCLASSIFIED
notes: NONE

Saving Text Header File: D001T026_HDR
Saving Text Data File: D001T026_TXT

Evaluating numbering scheme...
No errors were encountered during numbering scheme evaluation.
Numbering scheme evaluation complete.

Checking file count...
No errors were encountered during file count verification.
File Count verification complete.

No errors were encountered in Document D001.

No errors were encountered in this File Set.

MIL-STD-1840A File Set Evaluation Complete.

9.4 Other Tape Reading Logs

```
/cals/caps/Bin/read1840A: --- Read declaration file 'D001' --- /cals/caps/Bin/  
read1840A: writing data file 'aftb9471/TO31R2-2FRC181-3/TO31R22FRC18134.G.dtd'.  
/cals/caps/Bin/read1840A: writing data file 'aftb9471/TO31R2-2FRC181-3/  
TO31R22FRC18134.G.dtd'.  
/cals/caps/Bin/read1840A: writing data file 'aftb9471/TO31R2-2FRC181-3/  
TO31R22FRC18134.G.dtd'.  
/cals/caps/Bin/read1840A: writing data file 'aftb9471/TO31R2-2FRC181-3/  
TO31R22FRC18134.G.dtd'.  
/cals/caps/Bin/read1840A: writing data file 'aftb9471/TO31R2-2FRC181-3/  
M03B78.Q.igs'.  
/cals/caps/Bin/read1840A: writing data file 'aftb9471/TO31R2-2FRC181-3/  
M03B79.Q.igs'.  
/cals/caps/Bin/read1840A: writing data file 'aftb9471/TO31R2-2FRC181-3/  
M03B51.Q.igs'.  
/cals/caps/Bin/read1840A: writing data file 'aftb9471/TO31R2-2FRC181-3/  
M03B52.Q.igs'.  
/cals/caps/Bin/read1840A: writing data file 'aftb9471/TO31R2-2FRC181-3/  
M03B53.Q.igs'.
```

<<<<< PART OF LOG FILE REMOVED HERE >>>>>

```
/cals/caps/Bin/read1840A: writing data file 'aftb9471/TO31R2-2FRC181-3/  
M03B65.Q.igs'.  
/cals/caps/Bin/read1840A: writing data file 'aftb9471/TO31R2-2FRC181-3/  
M03B63.Q.igs'.  
/cals/caps/Bin/read1840A: writing data file 'aftb9471/TO31R2-2FRC181-3/  
M01B74.Q.igs'.  
/cals/caps/Bin/read1840A: writing data file 'aftb9471/TO31R2-2FRC181-3/  
HOW2IPB2.R.cci'.  
/cals/caps/Bin/read1840A: writing data file 'aftb9471/TO31R2-2FRC181-3/  
HOW2IPB1.R.cci'.  
/cals/caps/Bin/read1840A: writing data file 'aftb9471/TO31R2-2FRC181-3/  
W.T.sgm'.  
-- declaration file indicates 1 files of type T  
-- declaration file indicates 4 files of type G  
-- declaration file indicates 0 files of type H  
-- declaration file indicates 19 files of type Q  
-- declaration file indicates 2 files of type R  
-- declaration file indicates 0 files of type C  
-- declaration file indicates 0 files of type X  
-- declaration file indicates 0 files of type P  
-- declaration file indicates 0 files of type Z
```

10. Appendix B - Detailed IGES Analysis

10.1 File D001Q006

10.1.1 Parser/Verifier Log

```
*****  
***** IGES PARSER/VERIFIER *****  
***** MARCH 1993 *****  
***** IGES Data Analysis *****  
***** (708) 344-1815 *****  
*****
```

Input file is q006.igs
Checking conformance to CALS Class I (MIL-D-28000A 2/10/92)
Today is June 15, 1994 2:46 PM

```
*****  
***** CHECK FILE SYNTAX *****  
*****
```

Section	Records
Start	5
Global	3
Directory	3104 (1552 Entities)
Parameter	2786
Terminate	1

No syntax errors detected.

```
*****  
***** SUMMARY AND STATISTICS ****  
*****
```

*** File and Product Name Information ***

```
File name from sender = 'm03b.79.dwg'  
File creation Date.Time = '940413.135434'  
Model change Date.Time = ''  
Author = 'Earl Ratliffe'  
Department = ''  
Product name from sender = 'Xerox Expert'  
Destination product name = ''
```

*** Parameter Delimiters ***

Delimiter = ','
Terminator = ';'

*** Originating System Data ***

System ID = 'Xerox Expert version 5.0'
Preprocessor version = '5.0'
Specification version = 6 (IGES 4.0)

*** Precision levels ***

Integer bits = 16
Floating point - Exponent = 38 Mantissa = 7
Double precision - Exponent = 38 Mantissa = 7

*** Global Model Data ***

Model scale = 1.0000E+00
Unit flag = 1
Units = 'INCH'
Line weights = 3
Maximum line thickness = 4.166667E-02
Minimum line thickness = 1.388889E-02
Granularity = 1.000000E-05
Maximum coordinate = 1.100000E+01

Drafting standard applicable to original data is not specified.

*** Status Flag Summary ***

Blank status:	Visible	1552
	Blanked	0
Independence:	Independent	1450
	Physically Subordinate	100
	Logically Subordinate	2
	Totally Subordinate	0
Entity use:	Geometry	1527
	Annotation	22
	Definition	2
	Other	1
	Logical/Positional	0
	2D parametric	0
	Construction geometry	0
	Not Specified	0

Hierarchy: Structure DE applies 1552
 Subordinate DE applies 0
 Hierarchy property applies 0
 Not Specified 0

*** Entity Occurrence Counts ***

Entity	Form	Level	Count	Type
-----	----	-----	-----	-----
100	0	0	101	Circular arc
102	0	0	20	Composite curve
104	1	0	487	Conic arc - ellipse
110	0	0	412	Line
124	0	0	487	Transformation matrix
212	0	0	22	General note
230	0	0	20	Sectioned area (Standard Crosshatching)
404	0	0	1	Drawing
406	16	0	1	Property - Drawing size
410	0	0	1	View - Orthographic parallel

*** Entity Count by Level ***

Level	Count
0	1552

*** Labeling Information ***

100% of the entities are labeled.

Unlabeled 0

Label	Count	Label	Count	Label	Count
View	1*	Line	412*	Matrix	487*
Ellipse	487*	Arc	101*	GNote	22*
Composit	20	Section	20*	Property	1
Drawing	1*				

NITPICK 2327: One or more of the flagged entity labels are not right-justified.

*** Line Fonts Used in Data ***

100	102	104	106	108	110	112	114	
-	-	-	-	-	-	-	-	Undefined
42	20	319	-	-	186	-	-	Solid
-	-	-	-	-	4	-	-	Dashed
55	-	168	-	-	178	-	-	Phantom
-	-	-	-	-	37	-	-	Center-line
4	-	-	-	-	7	-	-	Dotted
-	-	-	-	-	-	-	-	User defined
116	118	120	122	124	125	126	128	
-	-	-	-	-	-	-	-	Undefined
-	-	-	-	487	-	-	-	Solid

<<<<< PART OF LOG FILE REMOVED HERE >>>>>

*** Line Widths Used in Data ***

Weight	Count	Width
Defaulted	892	(0.0139)
1	552	(0.0139)
2	4	(0.0278)
3	104	(0.0417)

*** Colors Used in Data ***

Defaulted	530
Green	1022

***** ENTITY ANALYSIS *****

*** Entity type: 100

*** Entity type: 102

ERROR 2033: End points of curves D 2885 and D 2887 disjoint by
5.188509E-02 at D 2893.
NOTE 2391: Start point D 2911 and D 2913 are the same, possible reversal
of D 2913.
ERROR 2033: End points of curves D 2913 and D 2915 disjoint by
5.188431E-02 at D 2917.
ERROR 2033: Messages regarding disjoint composite curves suppressed.

NOTE 2391: Start point D 2935 and D 2937 are the same, possible reversal
of D 2937.

<<<< PART OF LOG FILE REMOVED HERE >>>>

*** Entity type: 104

WARNING 2265: Start point off conic by 1.050720E-04 at D 237. WARNING 2039:
End point off conic by 1.050720E-04 at D 237. WARNING 2265: Messages regarding
invalid start point suppressed.
WARNING 2039: Messages regarding conic end points suppressed.

*** Entity type: 110

-- 412 lines averaging 2.821759E-01 units --

*** Entity type: 124

487 transformation matrices, 487 non-zero translations.
NOTE 2341: 487 matrices contain translation information.

*** Entity type: 212

22 text strings in data file.
Average text aspect ratio in file is 0.9141587.
Minimum text aspect ratio in file is 0.8409089.
Maximum text aspect ratio in file is 0.9176479.

FONTS USED IN FILE

FONT	COUNT	NAME
1	22	Default ASCII Style

*** Entity type: 230

NITPICK 2076: Entity does not have Annotation flag set at D 2871.
NITPICK 2076: Entity does not have Annotation flag set at D 2883.
NITPICK 2076: Messages regarding entity use (annotation) suppressed.

*** Entity type: 404

NITPICK 2074: Entity use flag must be 1 for Drawing entity at D 3103.
Drawing at D 3103 contains 1 views.
Drawing at D 3103 contains 0 annotation entities.

*** Entity type: 406

*** Entity type: 410

NITPICK 2073: Entity use flag must be 1 for View entity at D 1.
Scale of view at D 1 is 1.000000E+00.

Orthographic View entity at D 1 has 0 clipping planes specified.

XMIN = Not Set	XMAX = Not Set
YMIN = Not Set	YMAX = Not Set
ZMIN = Not Set	ZMAX = Not Set

*** Message Summary ***

2007: 29 Mathematical discontinuities.
2015: 124 Mathematically incorrect definitions.
2016: 22 Invalid entity use flag.

*** Error Summary ***

0 fatal errors
0 severe errors
29 errors
124 warnings
0 cautions
23 nitpicks
8 notes

*** End of Analysis of q006.igs ***

10.1.2 Parser Log - IGES/Works

IGES/Works v1.4.1
International TechneGroup Incorporated
Validation Logfile

Date: June 15, 1994
Model: q006

***** Validation Parameters *****

TOLERANCE CONFIGURATION VALUES

ZERO_TOL = 1.000000e-13
MODEL_SPACE_PNT_COIN_TOL = 1.000000e-03

<<<<< PART OF LOG FILE REMOVED HERE >>>>>

***** Entity Listing Before Validation *****

Count	Type	Form	Description
-----	----	----	-----
101	100	0	Circular Arc
20	102	0	Composite Curve
487	104	1	Ellipse
412	110	0	Line
487	124	0	Transformation Matrix
22	212	0	General Note (Simple)
20	230	0	Section Area (Standard Fill)
1	404	0	Drawing (form 0)
1	406	16	Property (Drawing Size)
1	410	0	View

1552 - Number of entities in selection list

***** Entity Validation *****

*** Warning (IEVM_LABEL_NOT_RJ) ***

(DE 1, TF 410:0) The Label Display field in this entity's DE section was not set for right justification.

Action taken: The Label Display field has been set to be right-justified.

<<<<< PART OF LOG FILE REMOVED HERE >>>>>

*** Warning (IEVM_BAD_VECTOR_124) ***
 (DE 17, TF 124:0) This Transformation Matrix entity (124) has a a column that is not a unit vector within the stated tolerance.
 Action taken: All vectors have been unitized.

<<<< PART OF LOG FILE REMOVED HERE >>>>

*** Warning (IEVM_BAD_START_POINT_104) ***
 (DE 35, TF 104:1) The start point for this Conic Arc entity (104) is not on the conic. Start point value found was -5.3820980e-07, 7.0296620e-01.
 Action taken: The start point has been moved 8.1290970e-04 units, from -5.3820980e-07, 7.0296620e-01 to -8.1344791e-04, 7.0296620e-01.

*** Warning (IEVM_BAD_END_POINT_104) ***
 (DE 35, TF 104:1) The end point for this Conic Arc entity (104) is not on the conic. Start point value found was 1.8058190e-07, -7.0296610e-01.
 Action taken: The end point has been moved 1.0406654e-03 units, from 1.8058190e-07, -7.0296610e-01 to 1.0408460e-03, -7.0296610e-01.

<<<< PART OF LOG FILE REMOVED HERE >>>>

*** Warning (IEVM_NON_CONTINUOUS_102) ***
 (DE 2893, TF 102:0) This Composite Curve entity (102) is not continuous within the stated tolerance. The terminate point of the first curve does not equal the start point of the next curve.
 Action taken: The curve was made continuous by the following actions. DE 2885 was reversed. DE 2887 was reversed. DE 2889 was reversed. DE 2891 was reversed.

<<<< PART OF LOG FILE REMOVED HERE >>>>

Entity Validation Summary:

Type	Form	Entity Count	Number Valid	Number of Corrected Warnings	Number of Corrected Errors	Number of Uncorrected Warnings	Number of Uncorrected Errors
Global Section		1	1	0	0	0	0
100	0	101	0	101	0	0	0
102	0	20	8	0	12	0	0
104	1	487	0	487	393	0	0
110	0	412	0	412	0	0	0
124	0	499	12	487	231	0	0
212	0	22	0	22	0	0	0
230	0	20	0	20	0	0	0
404	0	1	0	1	0	0	0
406	16	1	1	0	0	0	0
410	0	1	0	1	0	0	0
Totals:		1565	22	1531	636	0	0

The following message was issued and suppressed 1526 times:

The Label Display field in this entity's DE section was not set for right justification.

The following message was issued and suppressed 7 times:

This Composite Curve entity (102) is not continuous within the stated tolerance. The terminate point of the first curve does not equal the start point of the next curve.

The following message was issued and suppressed 194 times:

The start point for this Conic Arc entity (104) is not on the conic. Start point value found was $%.7e$, $%.7e$.

The following message was issued and suppressed 189 times:

The end point for this Conic Arc entity (104) is not on the conic. Start point value found was $%.7e$, $%.7e$.

The following message was issued and suppressed 226 times:

This Transformation Matrix entity (124) has a a column that is not a unit vector within the stated tolerance.

A message is suppressed when it has been issued more than 5 times. This value is controlled by the 'MAX_MESSAGE' configuration parameter.

10.1.3 Output Cadkey v6.0 - Detail

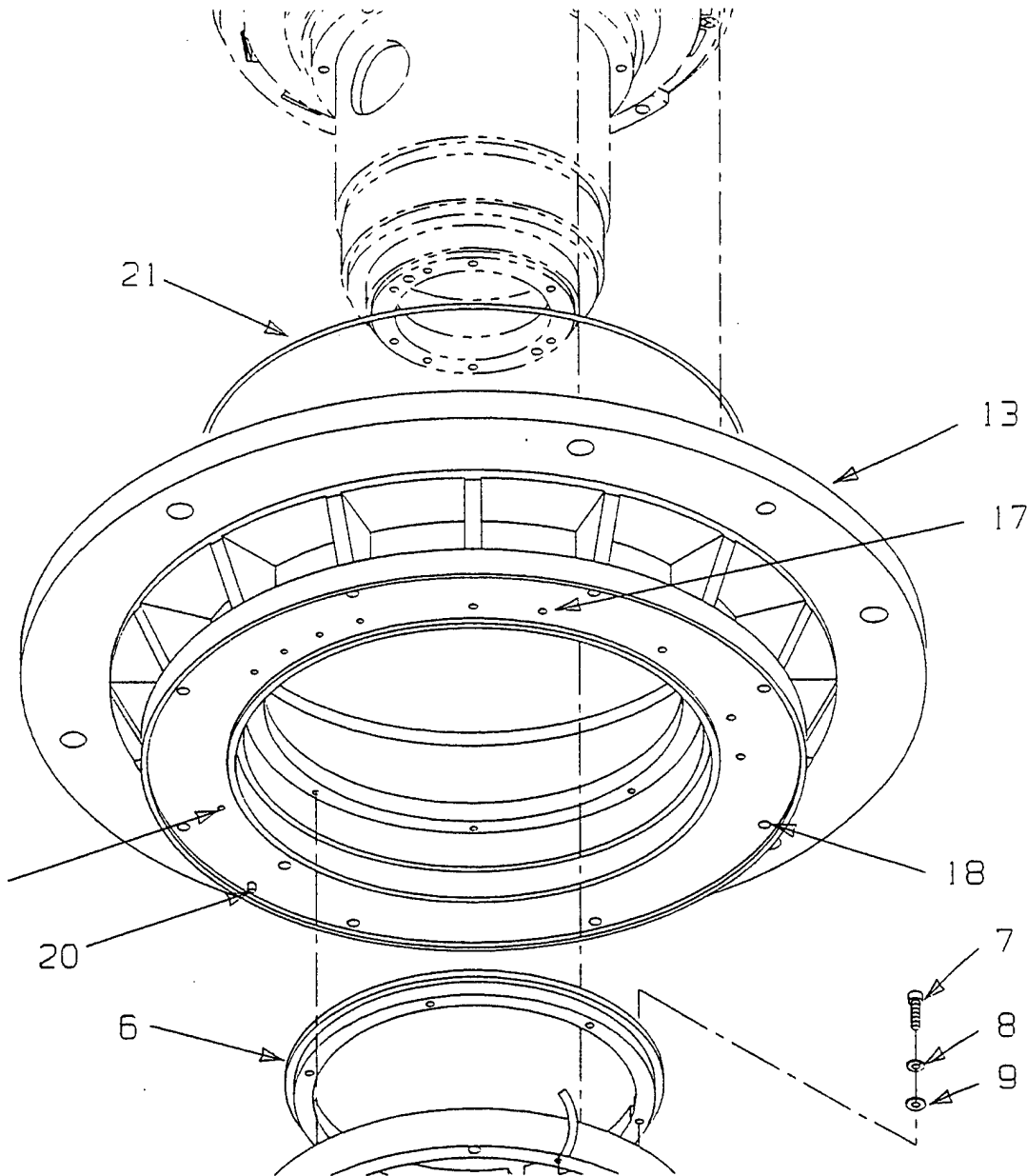

10.1.4 Output CADLeaf - Detail

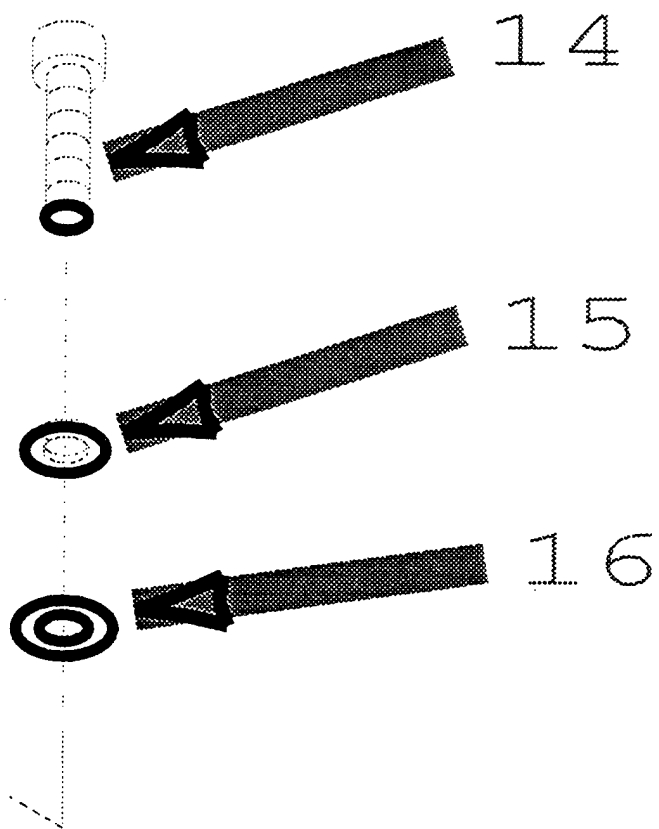

10.1.5 Output Island Draw

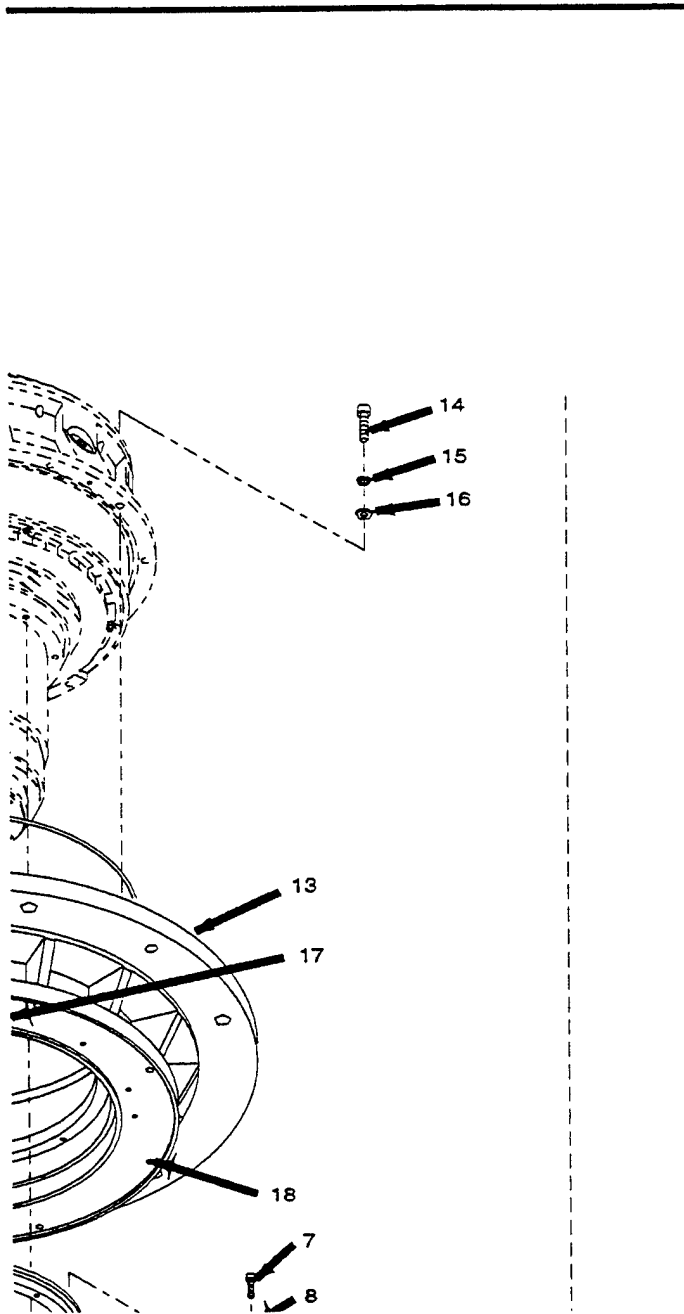

10.1.6 Output IGESView

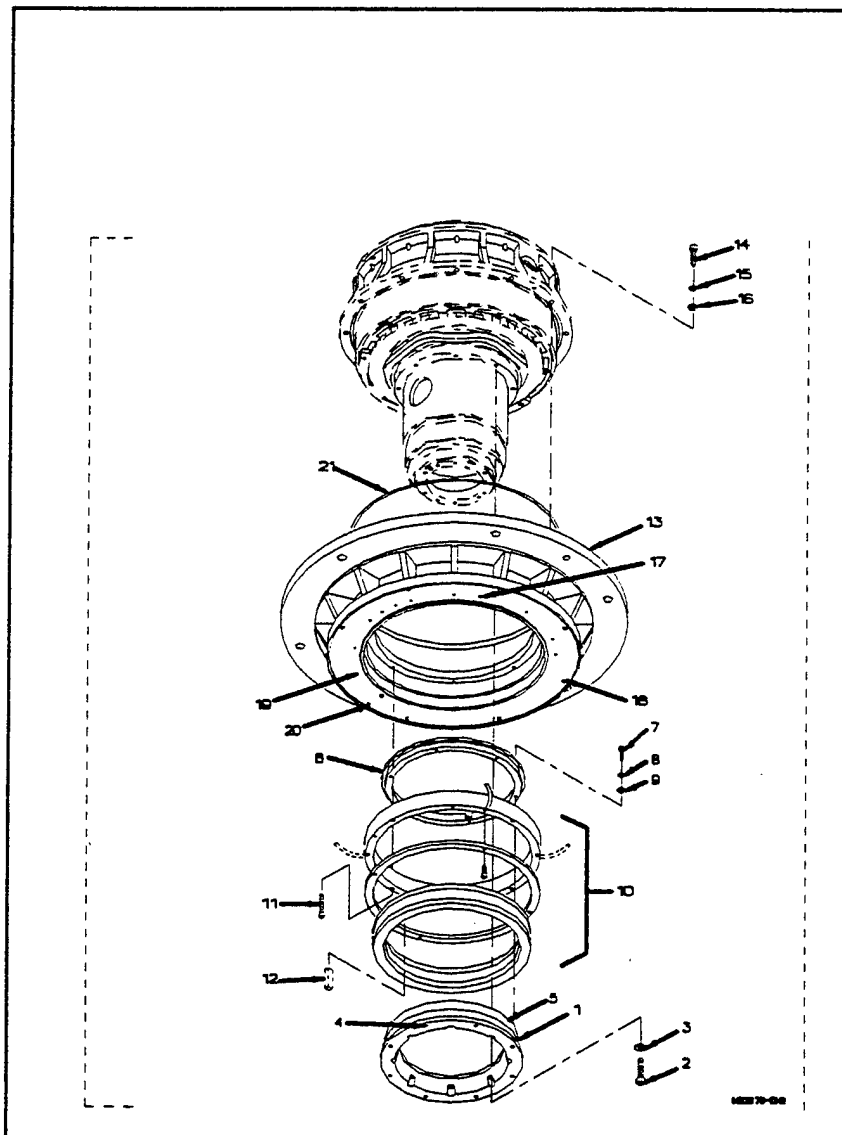

10.1.7 Output IGES/Works - Detail

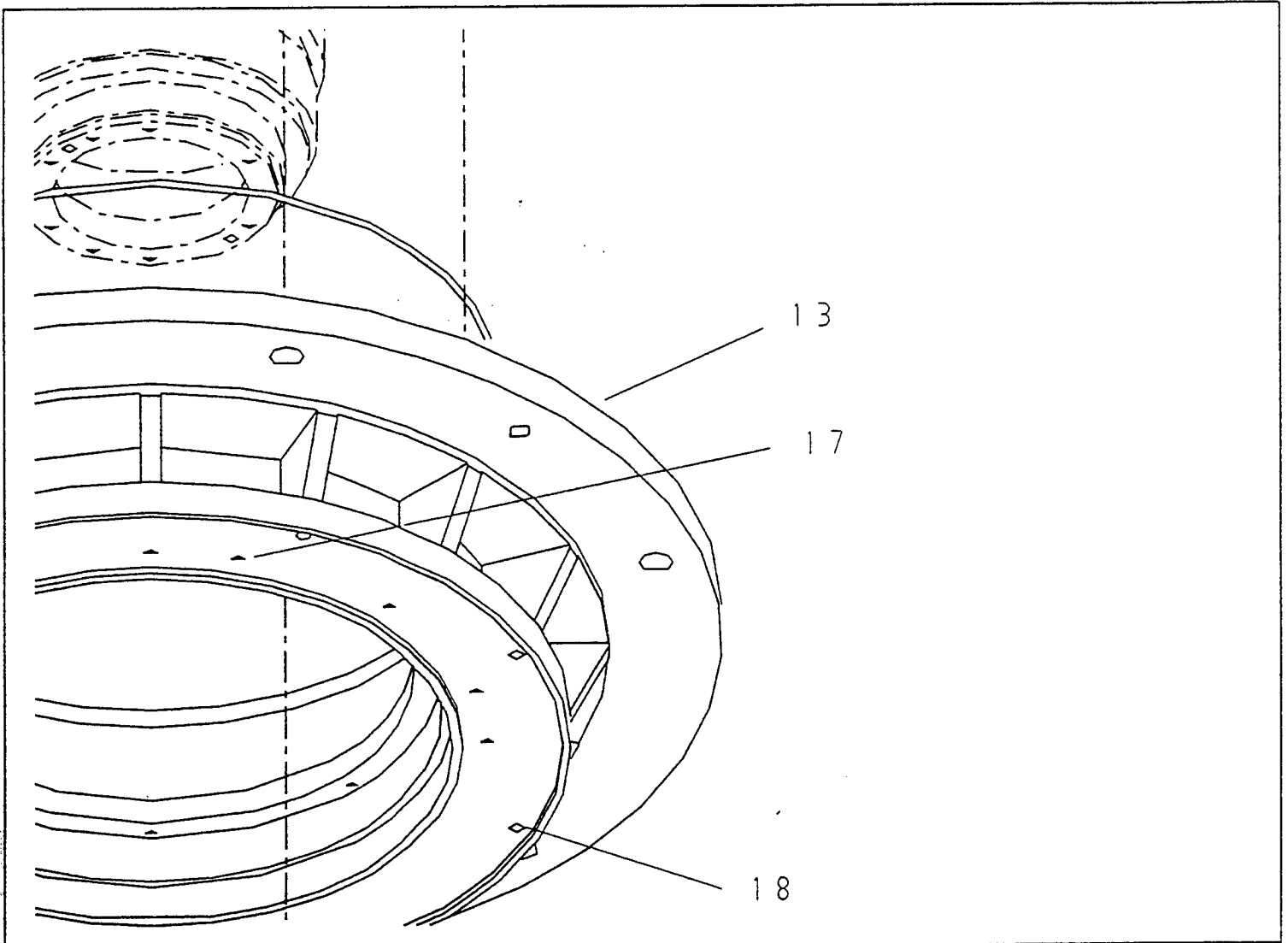

10.1.8 Output Preview

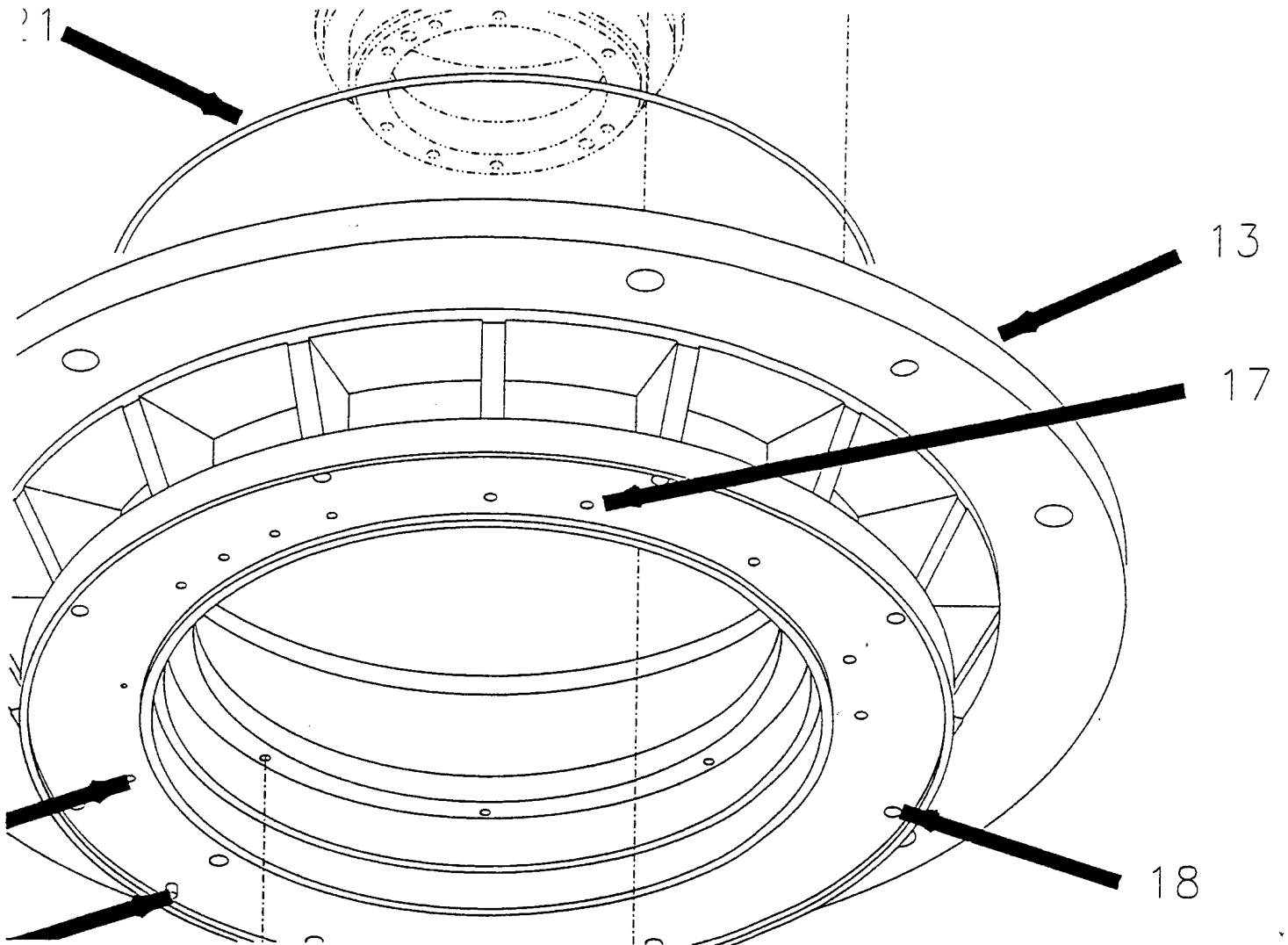

10.2 File D001Q020

10.2.1 Parser/Verifier Log

```
*****  
**** IGES PARSER/VERIFIER ****  
**** MARCH 1993 ****  
**** IGES Data Analysis ****  
**** (708) 344-1815 ****  
*****
```

Input file is q020.igs
Checking conformance to CALS Class I (MIL-D-28000A 2/10/92)
Today is June 15, 1994 2:46 PM

```
*****  
**** CHECK FILE SYNTAX ****  
*****
```

Section	Records
Start	5
Global	3
Directory	8960 (4480 Entities)
Parameter	7112
Terminate	1

No syntax errors detected.

```
*****  
**** SUMMARY AND STATISTICS ****  
*****
```

*** File and Product Name Information ***

File name from sender = 'M03B.64.dwg'
File creation Date.Time = '940413.134524'
Model change Date.Time = ''
Author = 'Earl Ratliffe'
Department = ''
Product name from sender = 'Xerox Expert'
Destination product name = ''

*** Parameter Delimiters ***

Delimiter = ','
Terminator = ';'

*** Originating System Data ***

System ID = 'Xerox Expert version 5.0'
Preprocessor version = '5.0'
Specification version = 6 (IGES 4.0)

*** Precision levels ***

Integer bits = 16
Floating point - Exponent = 38 Mantissa = 7
Double precision - Exponent = 38 Mantissa = 7

*** Global Model Data ***

Model scale = 1.0000E+00
Unit flag = 1
Units = 'INCH'
Line weights = 3
Maximum line thickness = 4.166667E-02
Minimum line thickness = 1.388889E-02
Granularity = 1.000000E-05
Maximum coordinate = 1.800000E+01

Drafting standard applicable to original data is not specified.

*** Status Flag Summary ***

Blank status:	Visible	4480
	Blanked	0
Independence:	Independent	4478
	Physically Subordinate	0
	Logically Subordinate	2
	Totally Subordinate	0
Entity use:	Geometry	4410
	Annotation	67
	Definition	2
	Other	1
	Logical/Positional	0
	2D parametric	0
	Construction geometry	0
	Not Specified	0

Hierarchy: Structure DE applies 4480
 Subordinate DE applies 0
 Hierarchy property applies 0
 Not Specified 0

*** Entity Occurrence Counts ***

Entity	Form	Level	Count	Type
100	0	0	179	Circular arc
104	1	0	1195	Conic arc - ellipse
110	0	0	1841	Line
124	0	0	1195	Transformation matrix
212	0	0	67	General note
404	0	0	1	Drawing
406	16	0	1	Property - Drawing size
410	0	0	1	View - Orthographic parallel

*** Entity Count by Level ***

Level	Count
0	4480

*** Labeling Information ***

100% of the entities are labeled.

Unlabeled 0

Label	Count	Label	Count	Label	Count
View	1*	Line	1841*	Matrix	1195*
Ellipse	1195*	GNote	67*	Arc	179*
Property	1	Drawing	1*		

NITPICK 2327: One or more of the flagged entity labels are not right-justified.

*** Line Fonts Used in Data ***

100	102	104	106	108	110	112	114	
-	-	-	-	-	-	-	-	Undefined
172	-	743	-	-	1030	-	-	Solid
-	-	-	-	-	-	-	-	Dashed
-	-	-	-	-	-	-	-	Phantom
-	-	-	-	-	51	-	-	Center-line
7	-	452	-	-	760	-	-	Dotted
-	-	-	-	-	-	-	-	User defined

116 118 120 122 124 125 126 128
- - - - - - - - Undefined
- - - - 1195 - - - Solid

<<<<< PART OF LOG FILE REMOVED HERE >>>>>

*** Line Widths Used in Data ***

Weight	Count	Width
Defaulted	2903	(0.0139)
1	1265	(0.0139)
3	294	(0.0417)
2	18	(0.0278)

*** Colors Used in Data ***

Defaulted	1198
Green	3282

***** ENTITY ANALYSIS *****

*** Entity type: 100

ERROR 2242: Radii not equal at D 8475; difference is 1.023141E-05.
ERROR 2242: Radii not equal at D 8687; difference is 1.057914E-05.
ERROR 2242: Radii not equal at D 8703; difference is 1.051452E-05.
ERROR 2242: Radii not equal at D 8771; difference is 1.311668E-05.
ERROR 2242: Radii not equal at D 8773; difference is 1.311668E-05.

*** Entity type: 104

WARNING 2265: Start point off conic by 3.067070E-05 at D 43.
WARNING 2039: End point off conic by 3.066063E-05 at D 43.
WARNING 2265: Messages regarding invalid start point suppressed.
WARNING 2039: Messages regarding conic end points suppressed.

*** Entity type: 110

-- 1841 lines averaging 1.479972E-01 units --

*** Entity type: 124

1195 transformation matrices, 1195 non-zero translations.
NOTE 2341: 1195 matrices contain translation information.

*** Entity type: 212

67 text strings in data file.
Average text aspect ratio in file is 0.8953497.
Minimum text aspect ratio in file is 0.7219515.
Maximum text aspect ratio in file is 0.9366667.

FONTS USED IN FILE

FONT	COUNT	NAME
1	67	Default ASCII Style

*** Entity type: 404

NITPICK 2074: Entity use flag must be 1 for Drawing entity at D 8959.
Drawing at D 8959 contains 1 views.
Drawing at D 8959 contains 0 annotation entities.

*** Entity type: 406

*** Entity type: 410

NITPICK 2073: Entity use flag must be 1 for View entity at D 1.
Scale of view at D 1 is 1.000000E+00.
Orthographic View entity at D 1 has 0 clipping planes specified.
XMIN = Not Set XMAX = Not Set
YMIN = Not Set YMAX = Not Set
ZMIN = Not Set ZMAX = Not Set

*** Message Summary ***

2015: 1146 Mathematically incorrect definitions.
2016: 2 Invalid entity use flag.

*** Error Summary ***

0 fatal errors
0 severe errors
5 errors
1141 warnings
0 cautions
3 nitpicks
1 notes

*** End of Analysis of q020.igs ***

10.2.2 Output Cadkey V6.0 - Detail

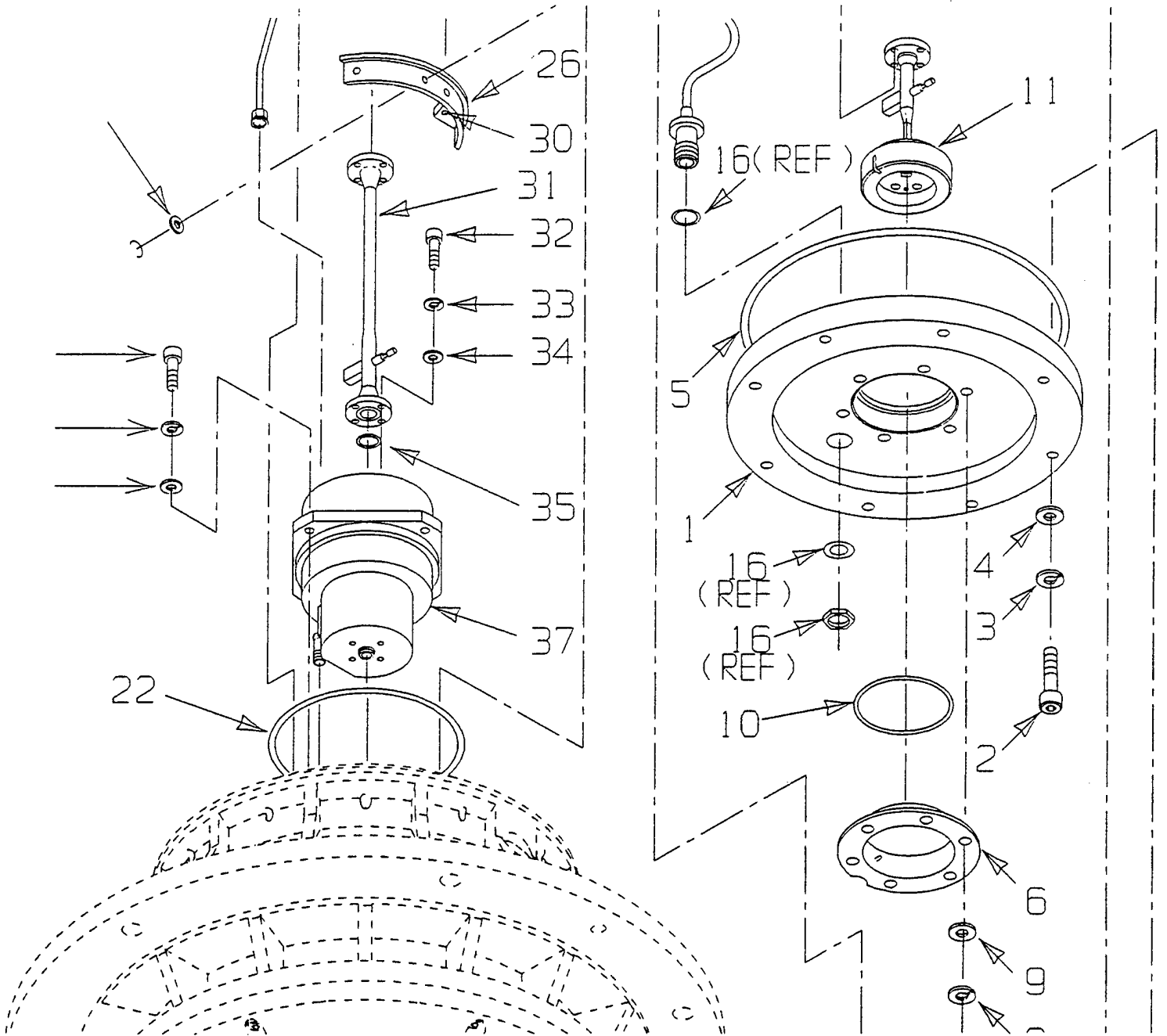

10.2.3 Output CADLeaf

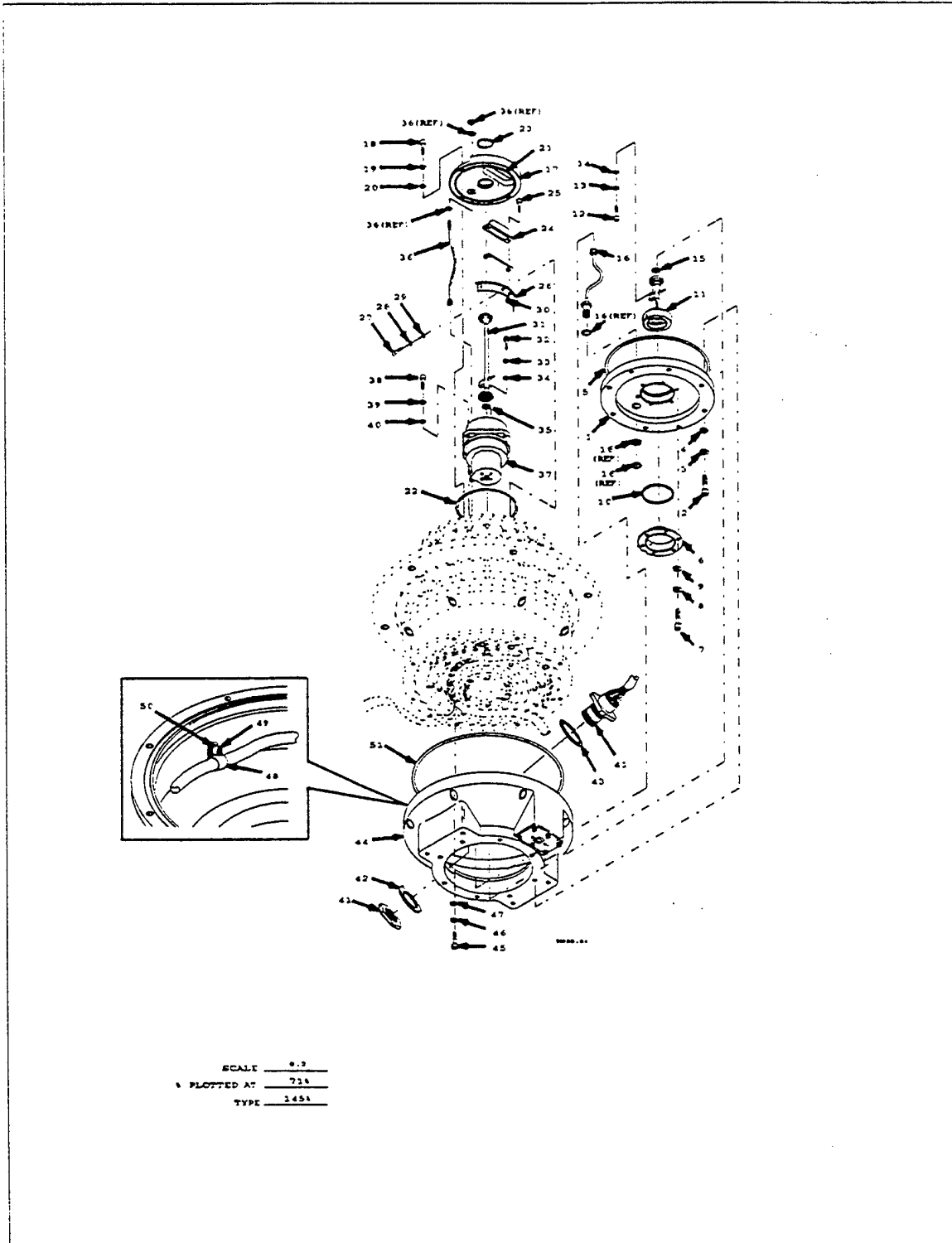

10.2.4 Output Island Draw

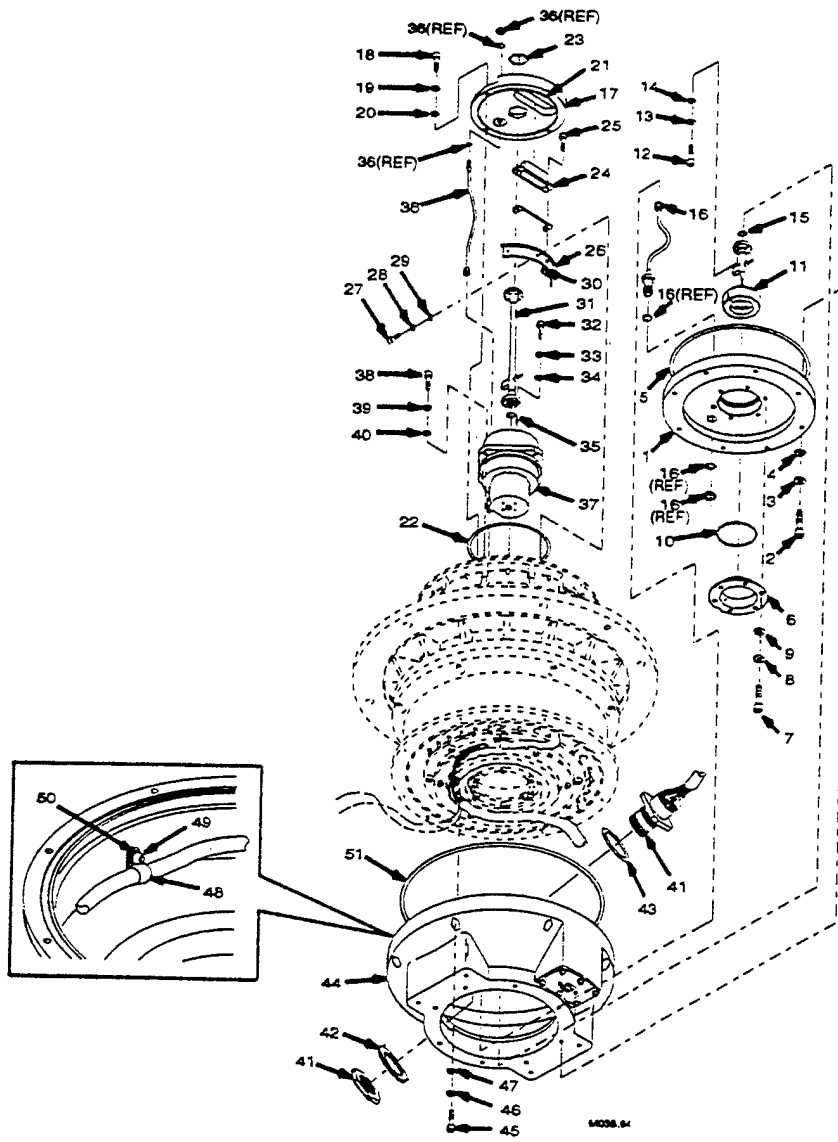

SCALE 0.2
% PLOTTED AT 71%
TYPE 145%

10.2.5 Output IGESView

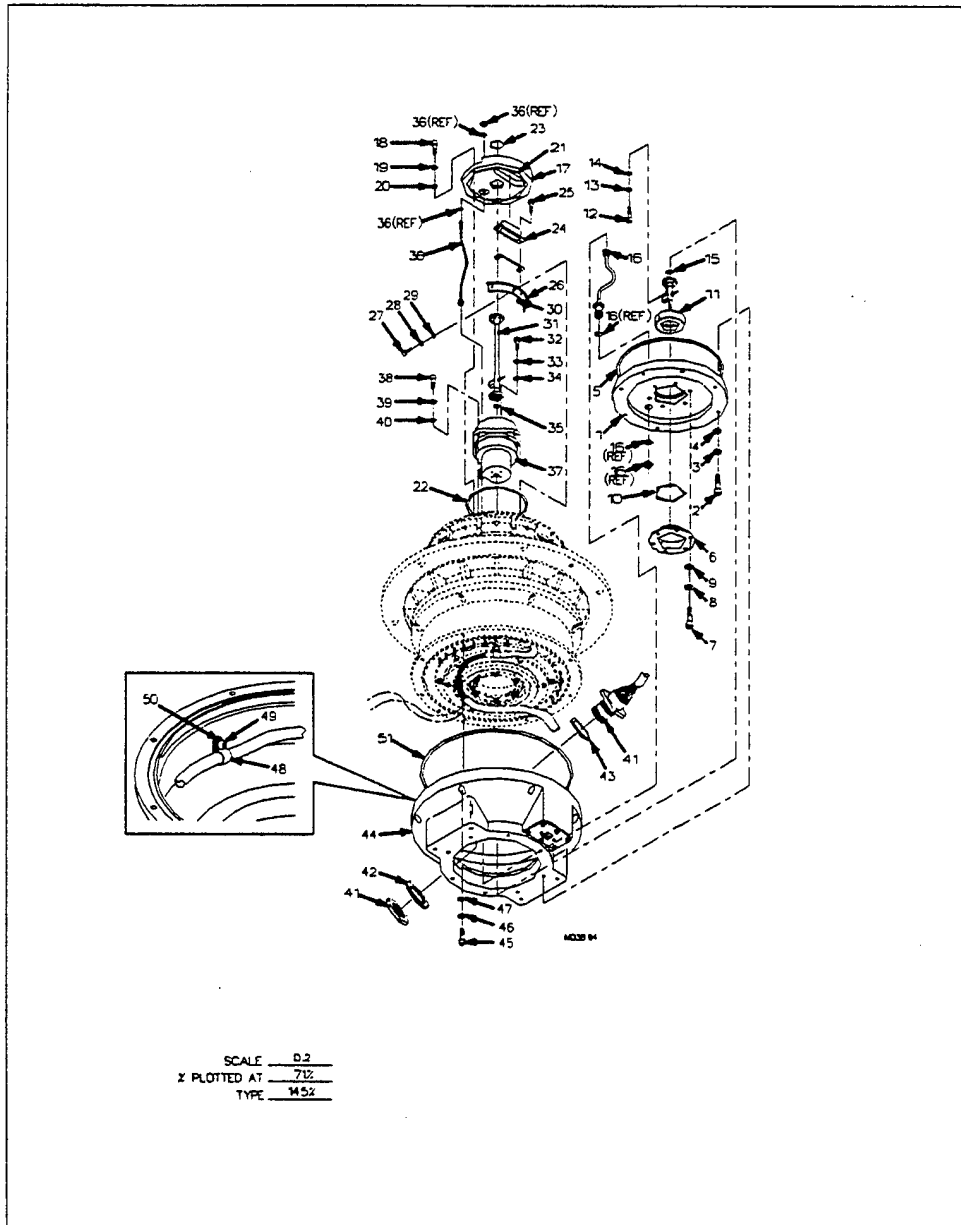

10.2.6 Output IGES/Works - Detail

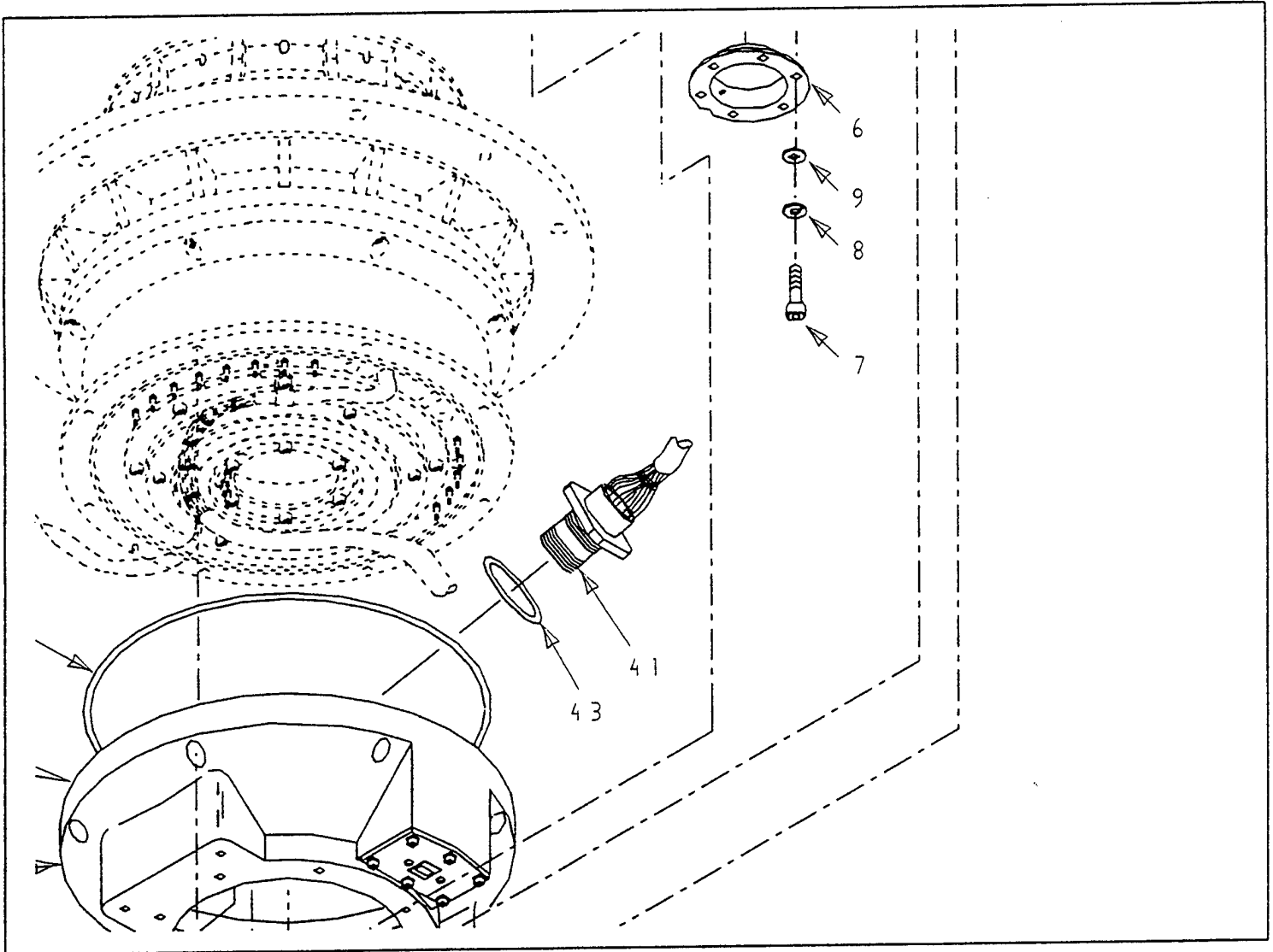

10.2.7 Output Preview - Detail

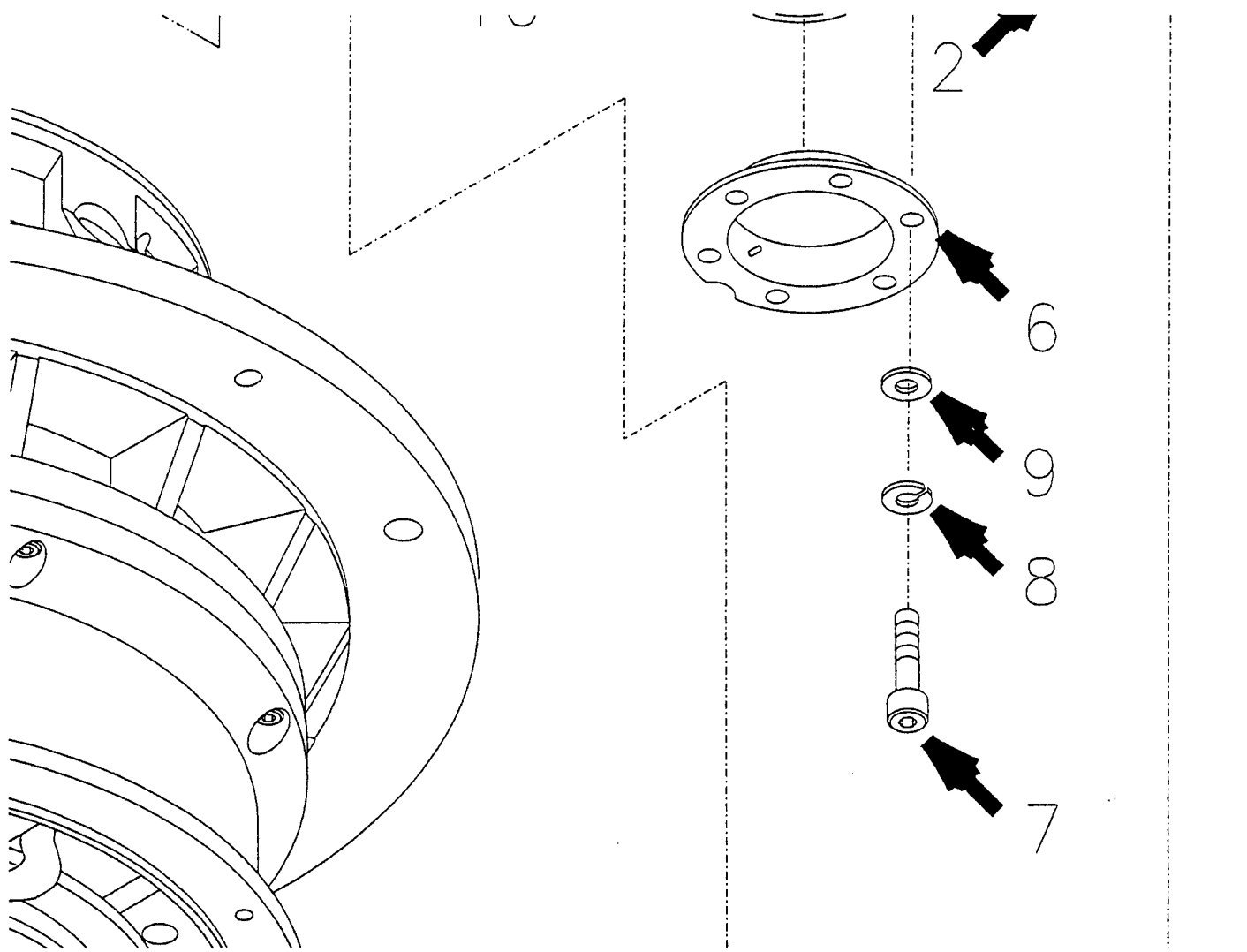

10.2.8 Output X-Change

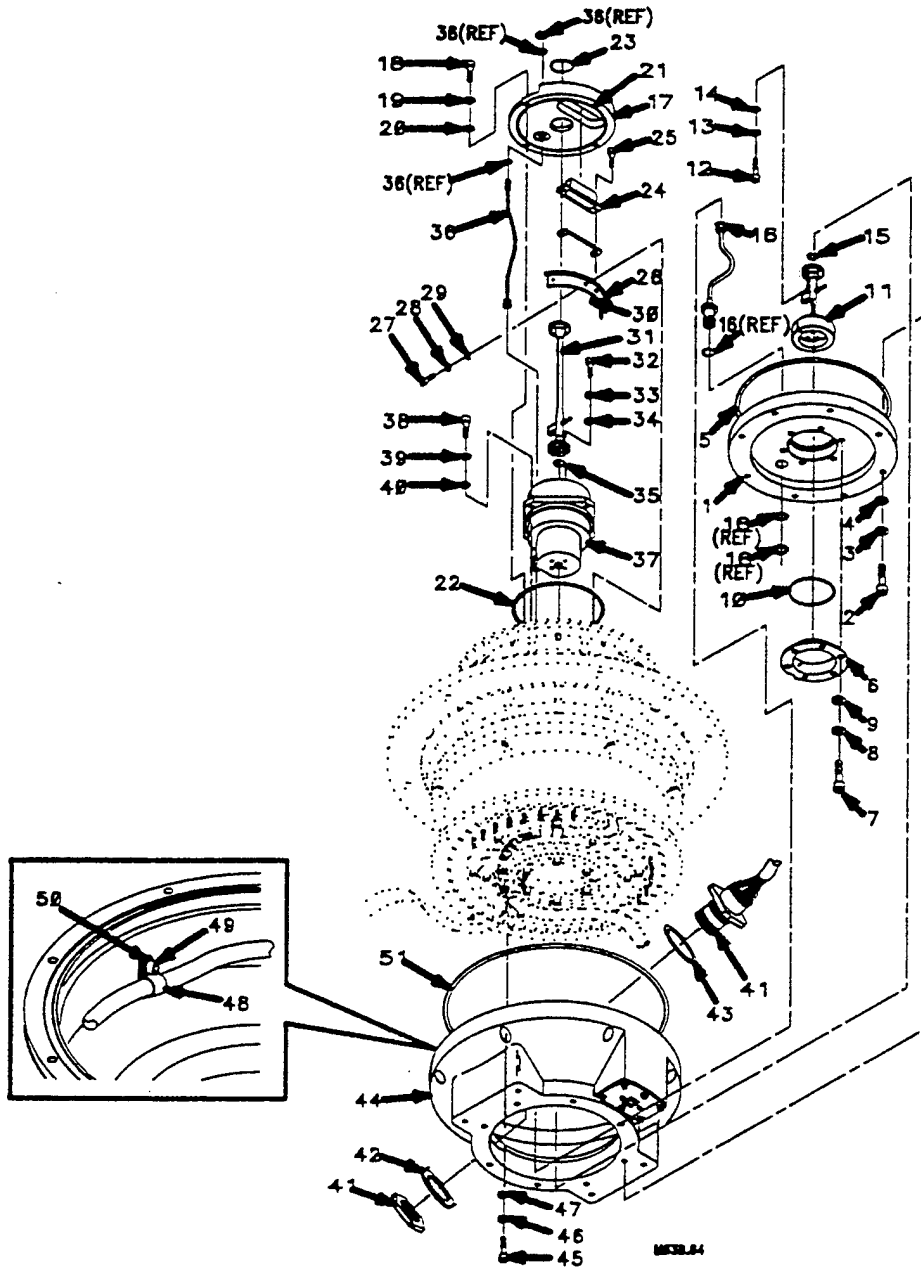

SCALE 8.2
% PLOTTED AT 71%
TYPE 145%

11. Appendix C - Detailed SGML Analysis

11.1 Exoterica Validator Parser

```
<!-- **Warning** in "i:\94071\BSPEC.DTD" (entity "%BSPEC"), line 342,  
      used in "\xgml\9471.dtd", line 165:  
      An element with mixed content should not permit data characters  
      ("PCDATA") everywhere.  
      The element being declared is "WARNING".  
      <!ELEMENT warning - - (title?, (%txt; | para | list)+) >  
                                          /\n-->
```

12. Appendix D - Detailed Raster Analysis

12.1 File D001R024

12.1.1 Output CADLeaf - As received (W/B)

HOW TO USE THE ILLUSTRATED PARTS BREAKDOWN

WHEN THE PART NUMBER OR REFERENCE DESIGNATION IS KNOWN

1. When the part number is known, locate the part number in the Numerical Index. Note the assigned figure and index number.
2. For information regarding the part, refer to the MPL legend associated with the figure and index number.
3. For a pictorial representation of the part, refer to the associated figure and locate the index number.
4. When the reference designator is known, locate it in a MPL description column. Note the assigned part number, then refer back to step 1.

12.1.2 Output CADLeaf - Reversed Color (B/W)

HOW TO USE THE ILLUSTRATED PARTS BREAKDOWN

WHEN THE PART NUMBER OR REFERENCE DESIGNATION IS KNOWN

1. When the part number is known, locate the part number in the Numerical Index. Note the assigned figure and index number.
2. For information regarding the part, refer to the MPL legend associated with the figure and index number.
3. For a pictorial representation of the part, refer to the associated figure and locate the index number.
4. When the reference designator is known, locate it in a MPL description column. Note the assigned part number, then refer back to step 1.