



CTN Report
90-008

UCID 21899



The CALS Test Network MIL-D-28000 Class I Reference Illustration Packet Revision A

January 19, 1990

DISTRIBUTION STATEMENT A
Approved for public release
Distribution Unlimited

19960822 109



Prepared for
Air Force Logistics Command
AITI Project



Lawrence Livermore National Laboratory

DTIC QUALITY INSPECTED 3

DISCLAIMER NOTICE

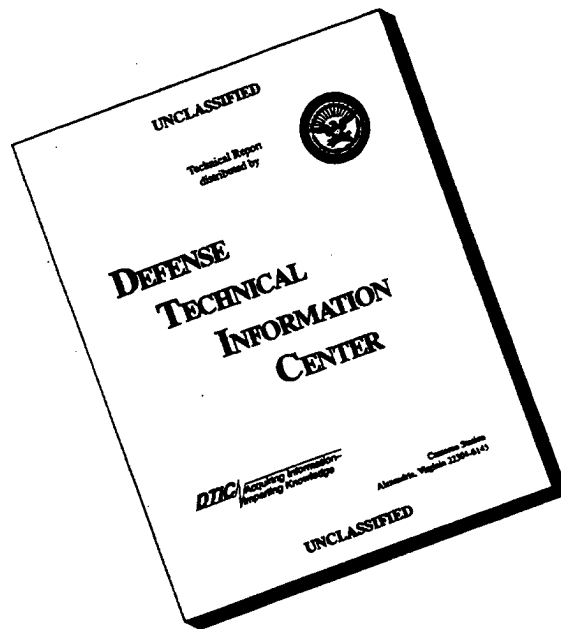

THIS DOCUMENT IS BEST QUALITY AVAILABLE. THE COPY FURNISHED TO DTIC CONTAINED A SIGNIFICANT NUMBER OF PAGES WHICH DO NOT REPRODUCE LEGIBLY.

**The CALS Test Network
MIL-D-28000 Class I
Reference Illustration Packet
Revision A**

January 19, 1990

Prepared by
Lawrence Livermore
National Laboratory

LLNL Contact
Jill Farrell
(415) 423-6348

AFLC Contact
Mel Lammers
(513) 257-3085



Prepared for
Air Force Logistics Command
AITI Project



Lawrence Livermore National Laboratory

DISCLAIMER

This document was prepared as an account of work sponsored by an agency of the United States Government. Neither the United States Government nor the University of California nor any of their employees, makes any warranty, express or implied, or assumes any legal liability or responsibility for the accuracy, completeness, or usefulness of any information, apparatus, product, or process disclosed, or represents that its use would not infringe privately owned rights. Reference herein to any specific commercial products, process, or service by trade name, trademark, manufacturer, or otherwise, does not necessarily constitute or imply its endorsement, recommendation, or favoring by the United States Government or the University of California. The views and opinions of authors expressed herein do not necessarily state or reflect those of the United States Government or the University of California, and shall not be used for advertising or product endorsement purposes.

This report has been reproduced
directly from the best available copy.

Available to DOE and DOE contractors from the
Office of Scientific and Technical Information
P.O. Box 62, Oak Ridge, TN 37831
Prices available from (615) 576-8401, FTS 626-8401.

Available to the public from the
National Technical Information Service
U.S. Department of Commerce
5285 Port Royal Rd.,
Springfield, VA 22161

<u>Price Code</u>	<u>Page Range</u>
A01	Microfiche
<u>Papercopy Prices</u>	
A02	1- 10
A03	11- 50
A04	51- 75
A05	76-100
A06	101-125
A07	126-150
A08	151-175
A09	176-200
A10	201-225
A11	226-250
A12	251-275
A13	276-300
A14	301-325
A15	326-350
A16	351-375
A17	376-400
A18	401-425
A19	426-450
A20	451-475
A21	476-500
A22	501-525
A23	526-550
A24	551-575
A25	576-600
A99	601 & UP

Contents

Preface	iii
Abstract	iv
1.0 Introduction	1
2.0 Content of the Reference Illustration Packet	1
3.0 Content and Creation of the Reference Material	2
3.1 The IENTITY Illustration	2
3.2 The LGTABLE Illustration	2
3.3 Development of the IGES Files	3
3.4 The Scripts	3
3.5 The Procedures	3
4.0 Conclusion	4
Attachment A: Procedures for Executing the CTN Reference Illustration IGES Pre-processor Test	
Attachment B: IENTITY Generation Script	
Attachment C: Procedures for Executing the CTN Reference Illustration IGES Post-processor Test	
Attachment D: IENTITY Evaluation Script	
Attachment E: LGTABLE Evaluation Notes	
Attachment F: IENTITY B-sized Plot	
Attachment G: LGTABLE A-sized Plot	
Attachment H: IENTITY IGES File Printout	
Attachment I: LGTABLE IGES File Printout	
Attachment J: IENTITY Entity Listing and Count	
Attachment K: LGTABLE Entity Listing and Count	

Preface

This CALS Test Network MIL-D-28000 Class I Reference Illustration Packet is a document which will have periodic updates. This will occur as the reference illustrations and their associated procedures, scripts, and files are corrected for oversights and/or are updated to new versions of the standards.

I acknowledge Ben Kassel of the CALS Navy Test Bed at the David Taylor Research Center for preparing the initial versions of the IENTITY test case and scripts. I also acknowledge McDonnell Aircraft Company for allowing the CALS Test Network to modify and use the LGTABLE illustration.

Please use the information contained in this packet at your own risk. Send recommendations for change or comments about the content to:

Jill Farrell
CALS Test Network, IGES Lead Analyst
Lawrence Livermore National Laboratory
P.O. Box 808 L-542
Livermore, CA 94550

Abstract

This CALS Test Network MIL-D-28000 Class I Reference Illustration Packet contains the information needed to conduct tests of the Technical Publication Subset, Class I, of the military specification MIL-D-28000 using IGES processors. The material is intended to demonstrate industry and government's use of MIL-D-28000 in accordance with the CALS initiative. The CALS Test Network (CTN) is the organization tasked with demonstrating this digital data interchange among industry and government and uses this packet during CTN testing. The packet is, furthermore, used by CTN members to conduct self-tests of their companies' abilities to utilize CALS data. The results derived from this testing will allow the CTN to suggest modifications to drafting techniques, vendors' IGES processors, the IGES specification, and most importantly, the MIL-D-28000 military specification.

The CALS Test Network MIL-D-28000 Class I
Reference Illustration Packet

1.0 Introduction

The DoD Computer-aided Acquisition and Logistic Support (CALS) Test Network (CTN) is conducting tests of the military standard for the Automated Interchange of Technical Information, MIL-STD-1840A (1840A) and its companion suite of military specifications. The CTN is a DoD sponsored confederation of voluntary participants from industry and government, managed jointly by the technical staff at Air Force Logistics Command (AFLC) and Lawrence Livermore National Laboratory (LLNL). The objective of the CTN tests is to demonstrate and evaluate the interchange and functional use of digital technical information between industry and government using the CALS Standards.

The IENTITY and the LGTABLE reference illustrations described herein are used by the CALS Test Network during user application testing of IGES data. They, furthermore, are used by CTN members during self-tests of their digital data transfer abilities. IGES is the Initial Graphics Exchange Specification used for interchanging graphical data between dissimilar computer aided design (CAD) and technical publication systems. Specifically, these reference illustrations demonstrate the use of the IGES entities identified in the Technical Publication Subset, Class I, of the military specification, MIL-D-28000. In addition to demonstrating the use of this military specification and subset, these illustrations also allow the CTN to demonstrate the use of MIL-D-28000's parent document, MIL-STD-1840A. MIL-STD-1840A standardizes the delivery "envelope" used by organizations to exchange digital forms of technical information.

2.0 Content of the Reference Illustration Packet

The CTN MIL-D-28000 Class I Reference Illustration Packet you are currently reading contains a set of reference material. This packet contains the pieces of information needed to execute a test using a vendor's IGES processors. It contains:

1. Procedures to follow to conduct a pre-processor test; pre-processing is the translation from a graphics system to an IGES file.
2. A generation script (a set of instructions) to follow to create the IENTITY illustration on any graphics system.

3. Procedures to follow to conduct a post-processor test; post-processing is the translation from an IGES file to a graphics system.
4. The IGES files on a 9-track tape in MIL-STD-1840A format of both the IENTITY and LGTABLE reference illustrations to post-process into the graphics system.
5. Evaluation scripts (sets of questions) to complete after the IENTITY and LGTABLE illustrations have appeared on the screen after post-processing.
6. Plots of the IENTITY and LGTABLE illustrations.
7. A paper printout of the IGES files for both the IENTITY and LGTABLE illustrations.
8. Entity listing and counts for both the IENTITY and LGTABLE illustrations.

The above-mentioned pieces of information are contained in the attachments labeled A through K which follow this general introduction.

3.0 Content and Creation of the Reference Material

3.1 The IENTITY Illustration

The IENTITY illustration is comprised of all the geometric, annotation, and structure IGES entities identified in the MIL-D-28000 Class I subset. The illustration is organized such that the entities reside individually by entity and form number within one box of a grid. This box is then labeled to show which entity it should contain. All entities are model mode entities, two-dimensional, and contained on layer zero as MIL-D-28000 Class I requires. The drawing, containing a single view, is B-sized.

3.2 The LGTABLE Illustration

The LGTABLE graphic is an example of an actual technical publication illustration that completely complies to MIL-D-28000 Class I. It does not contain every entity identified in MIL-D-28000 Class I, however, it does contain a good sampling of the frequently used entities such as lines, circles, splines, text, and fill. Again, all entities are model mode, two-dimensional, and located on layer zero. The single view is contained on an A-sized drawing.

The LGTABLE illustration is included in this packet to be used during post-processor testing only. Although very useful as a sample illustration, pre-processor testing information was not deemed appropriate for LGTABLE because of the illustration's size and complexity.

3.3 Development of the IGES Files

The IENTITY and LGTABLE illustrations were drafted on a CAD system, then pre-processed into IGES files. Because the pre-processed IGES files did not completely conform to IGES Version 4.0 and MIL-D-28000, did not include all desired Class I entities, and included unwanted volunteer entities, the files were hand edited. During this hand editing, the criteria discussed in the "Guide to Developing IGES Test Cases" written by the IGES Test Case Subcommittee of the National IGES/PDES Committee was adhered to where ever possible. This hand editing produced IGES files that incorporate all MIL-D-28000 Class I entities and pass several IGES analyzers with no accountable errors. The analyzers referred to are the IGES Model Testing System, the IGES Data Analysis Company Parser/Verify/View packages, and the Rosetta Technologies, Inc. PreVIEW software.

After the IGES files were thoroughly checked, MIL-STD-1840A headers were placed on the IGES files. Next, MIL-STD-1840A declaration files were written for each file. Lastly, all files were copied to a 9-track tape at MIL-STD-1840A-required formats.

3.4 The Scripts

This reference illustration packet contains two different sets of scripts. The generation script describes how to create the reference illustration on a graphics system during the pre-processor test. It is designed to be generic enough to allow illustration generation on any system. The evaluation scripts describe how to evaluate the graphical model that appears during a post-processor test. These scripts ask questions that try to address DoD's present requirements for a technical publication illustration digital transfer.

3.5 The Procedures

The CTN's test procedures contained herein discuss running tests on the pre-processors and post-processors separately. These procedures follow one proposed by the National IGES/PDES Organization's Testing Subcommittee. Other procedures were derived from available hardware and software resources and past experience.

Deviations and expansions from these procedures are encouraged as required by one's needs. An example of a deviation is to perform an end-to-end test with this reference data. These procedures do not address end-to-end testing because this type of testing is usually conducted with a user's actual illustrations, not reference illustrations. An end-to-end test with this packet's reference data could easily be conducted by, first,

following the pre-processor procedures and, second, sending that pre-processed IGES file through the post-processor procedures. As stated, deviations of this type are possible and should be used as experience and requirements dictate.

4.0 Conclusion

By following the procedures described in this CTN MIL-D-28000 Class I Reference Illustration Packet and by referring to the scripts, plots, and data lists also contained within, one can examine technical publication illustration digital transfers using IGES and MIL-D-28000. This packet does not validate a vendor's conformance to MIL-D-28000 Class I, but instead allows the CTN analysts and CTN members to demonstrate industry/government's use of the MIL-D-28000 specification in accordance with the CALS initiative.

Attachment A

Procedures for Executing the CTN Reference
Illustration IGES Pre-processor Test

Procedures for Executing the CTN Reference
Illustration IGES Pre-processor Test

1. Follow the "Generation Script" to create the IENTITY reference illustration on your native graphics system to the system's best abilities. Record any problems encountered or deviations taken while following the generic script on the attached incident report sheets. Use additional sheets if necessary.

Try to create the entities on the graphics system so that the desired IGES entity is pre-processed into the IGES file. The scripts specify which entities are the desired entities. To accomplish this, we recommend that these scripts be followed in the presence of both a knowledgeable system operator and an experienced IGES person, both people preferably supplied by the graphics system vendor itself. This will insure the best transfer possible with a particular vendor's software.

Furthermore, although the graphics system may not support the "desired" IGES entity, try to match the appearance of the illustration using other entities allowed in MIL-D-28000 Class I.

2. Pre-process the illustration into the IGES format using any available switches to create a MIL-D-28000 Class I file. Place the required MIL-D-28000 Class I Start Section information into the file. Record any errors the system reports.
3. Prepare a MIL-STD-1840A compliant 9-track tape containing the IENTITY IGES file and its corresponding declaration file. Be sure to include the proper MIL-STD-1840A header information to the IGES file and copy all files to the tape at the appropriate MIL-STD-1840A format. Record any difficulties experienced.
4. If you are conducting a self-test, collect the tape and all incident reports from steps 1, 2, and 3 for evaluation. If you pre-arranged a formal CTN test and obtained CTN approval, send the tape and all incident reports from steps 1, 2, and 3 to:

CALS Test Network, IGES Testing
Lawrence Livermore National Laboratory
P.O. Box 808, 7000 East Ave., L-542
Livermore, CA 94550

Refer questions to Jill Farrell at (415) 423-6348.

5. Evaluate the data. We at the CALS Test Network will and anyone conducting a self-test should:
 - a. Check the tape for proper MIL-STD-1840A formats.
 - b. Check the tape for appropriate MIL-STD-1840A declaration information.
 - c. Check the IGES file for appropriate MIL-STD-1840A header information.
 - d. Examine the IGES file visually for format and content.
 - e. Parse and verify the IGES file using various IGES analyzers to check for IGES syntax errors and illegal MIL-D-28000 Class I constructs.
 - f. View the graphics the IGES file generated with IGES viewing packages.
 - g. Pinpoint any file, IGES processor, IGES standard, and/or military standard inefficiencies using the above software and personal knowledge.
 - h. Bring the findings to the appropriate parties for correction (either vendor, graphics system operator, IGES Committee, or the military standard's sponsor).
 - i. CTN will publicly publish results of CTN findings.

Attachment B

IDENTITY Generation Script

I-ENTITY Generation Script

Part) Create a part named "IENTITY".

Drawing) If the CAD system allows for a separate drawing file within the part, create a B-sized drawing with its origin in the lower left-hand corner.

INSERT ALL ENTITIES WHILE WORKING IN THE TOP VIEW CONSTRUCTION PLANE. THIS CONSTRUCTION PLANE OR REQUIRED COORDINATE ORIENTATION IS SHOWN ON THE B-SIZED I-ENTITY PLOT. ALL MODEL COORDINATES (X,Y,Z) REFERRED TO IN THIS SCRIPT ARE BASED ON THIS COORDINATE ORIENTATION. ALL UNITS ARE INCHES.

CREATE THE FOLLOWING ENTITIES ON LEVEL ZERO AND IN THE DEFAULT COLOR OF THE CAD SYSTEM. INSERT ALL ENTITIES IN MODEL MODE. IN EVERY INSTANCE, TRY TO CREATE THE ENTITY ON THE CAD SYSTEM SUCH THAT UPON PRE-PROCESSING THE PART INTO IGES, THE DESIRED ENTITY AND FORM NUMBER APPEAR IN THE IGES FILE. THE DESIRED ENTITY AND FORM NUMBERS ARE THOSE NUMBERS ALONG THE LEFT-HAND MARGIN PRECEDING THE CREATION OR INSERTION COMMAND.

Grid lines)

Insert the following grid lines:

a)	from (0.5,10.5,0.0)	to (0.5,0.5,0.0)
b)	(2.5,10.5,0.0)	(2.5,0.5,0.0)
c)	(4.5,10.5,0.0)	(4.5,0.5,0.0)
d)	(6.5,10.5,0.0)	(6.5,0.5,0.0)
e)	(8.5,10.5,0.0)	(8.5,0.5,0.0)
f)	(10.5,10.5,0.0)	(10.5,0.5,0.0)
g)	(12.5,10.5,0.0)	(12.5,0.5,0.0)
h)	(14.5,10.5,0.0)	(14.5,0.5,0.0)
i)	(16.5,10.5,0.0)	(16.5,0.5,0.0)
j)	(0.5,0.5,0.0)	(16.5,0.5,0.0)
k)	(0.5,2.5,0.0)	(16.5,2.5,0.0)
l)	(0.5,4.5,0.0)	(16.5,4.5,0.0)
m)	(0.5,6.5,0.0)	(16.5,6.5,0.0)
n)	(0.5,8.5,0.0)	(16.5,8.5,0.0)
o)	(0.5,10.5,0.0)	(16.5,10.5,0.0)

100) Create a circular arc centered at (1.5,9.5,0.0) with a radius of 0.5 inches and traced out counterclockwise from 270 to 180 degrees.

102) a) Insert a line from (3.0,9.5,0.0) to (3.0,10.0,0.0).
b) Insert a line from (3.0,10.0,0.0) to (3.5,9.5,0.0).
c) Insert a cubic parametric spline through the points (3.5,9.5,0.0), (4.0,9.25,0.0), and (4.25,9.25,0.0).
d) Group the 2 lines and the spline together to form one entity. Use the composite curve entity (IGES entity 102) if your system supports it.

- 104 F0) a) Insert a conic with the general equation in standard form:

$$4x^2 + 16y^2 - 1 = 0$$

- b) Rotate this conic 90 degrees clockwise and center it around (5.5,9.5,0.0). This conic is then an ellipse with a major axis of 1.0 inches (paralleling the vertical axis) and a minor axis of 0.5 inches.

- 104 F1) Insert an ellipse centered at (7.5,9.5,0.0) with a major axis of 1.0 inches and a minor of 0.5 inches. Position the ellipse so that the major axis parallels the horizontal axis. The general equation of this conic centered at (7.5,9.5,0.0) in standard form is:

$$4x^2 + 16y^2 - 1 = 0$$

- 104 F2) Insert a horizontal hyperbola centered at (9.75,9.5,0.0) such that only the left side is visible and that it sweeps 0.25 inches on either side of the axis of symmetry toward the negative x-direction. The hyperbola's transverse axis length is 0.5 inches and conjugate axis length is 0.25 inches. Refer to the plot for a pictorial description. The general equation of this conic rotated 180 degrees about its tip with its tip at (9.5,9.5,0.0) in standard form is:

$$16x^2 - 64y^2 - 1 = 0$$

- 104 F3) Insert a vertical parabola with a vertex of (11.5,9.5,0.0) and the focus point at (11.5,9.75,0.0). Extend the parabola into the positive y-direction to make it 0.25 inches tall. Refer to the plot for a pictorial description. The general equation of this conic rotated 90 degrees counterclockwise about (11.5,9.5,0.0) in standard form is:

$$y^2 - x = 0$$

- 106 F11) a) Insert a circular arc centered at (13.5,9.25,0.0) with a radius of 0.5 and traced out counterclockwise from 0 to 180 degrees.
b) Transform the circular arc into a "linear planar curve" entity (IGES entity 106 Form 11) - a curved string of many short straight segments.

106 F63) Create a rectangle or a "simple closed area" entity (106 Form 63) consisting of one entity between the points:

(15.0,9.25,0.0)
(15.0,10.0,0.0)
(16.0,10.0,0.0)
(16.0,9.25,0.0)

110) Create a line from (1.5,7.0,0.0) to (1.5,8.0,0.0).

112) Create a cubic parametric spline curve through the points:

(3.0,8.0,0.0)
(3.75,7.75,0.0)
(4.0,7.5,0.0)
(4.0,7.25,0.0)
(3.75,7.0,0.0)
(3.5,7.0,0.0)
(3.25,7.25,0.0)
(3.25,7.5,0.0)
(4.0,8.0,0.0).

124 F0) a) Create a temporary coordinate system (construction plane) defined by the transformation matrix shown below. This coordinate system corresponds to a construction plane rotated 90 degrees counterclockwise with its origin at (5.5,7.5,0.0).

0.0	1.0	0.0	5.5
-1.0	0.0	0.0	7.5
0.0	0.0	1.0	0.0

b) Insert an arc centered at (0.0,0.0,0.0) swept between 0 and 180 degrees with a radius of 0.5 inches.

c) Return to the original coordinate system.

126 F0) Insert a rational b-spline curve through the points:
(7.0,7.0,0.0), (7.0,7.5,0.0), (7.0,8.0,0.0),
(7.5,8.0,0.0), (8.0,8.0,0.0), (8.0,7.5,0.0),
(8.0,7.0,0.0).

126 F1) Insert a rational b-spline curve through the points:
(9.0,7.5,0.0), (10.0,8.0,0.0). This curve approximates a line.

126 F2) Insert a rational b-spline curve through the points:
(12.0,7.5,0.0), (11.9045,7.79389,0.0),
(11.6545,7.97553,0.0), (11.3455,7.97553,0.0),
(11.0955,7.79389,0.0), (11.0,7.5,0.0). This curve approximates an arc.

- 126 F3) Insert a rational b-spline curve through the points:
 (14.0,7.5,0.0), (13.8528,7.67713,0.0),
 (13.6208,7.74259,0.0), (13.3792,7.74259,0.0),
 (13.1472,7.67713,0.0), (13.0,7.5,0.0). This curve
 approximates an elliptical arc.
- 126 F4) Insert a rational b-spline curve through the points:
 (16.0,7.75,0.0), (15.8231,7.60439,0.0),
 (15.6138,7.51295,0.0), (15.3862,7.51295,0.0),
 (15.1769,7.60439,0.0), (15.0,7.75,0.0). This curve
 approximates a parabolic arc.
- 126 F5) Insert a rational b-spline curve through the points:
 (1.25,5.71651,0.0), (1.36619,5.64544,0.0),
 (1.4722,5.56046,0.0), (1.47214,5.43958,0.0),
 (1.36622,5.35451,0.0), (1.25,5.28349,0.0). This curve
 approximates an hyperbolic arc.

FOR THE FOLLOWING GENERAL NOTE ENTITIES (212), USE THE STANDARD
 BLOCK (OR DEFAULT) TEXT FONT, A TEXT HEIGHT OF 0.125 INCHES, AND
 A TEXT WIDTH OF 0.1 INCHES. SELECT THE TEXT ORIGIN (OF THE FIRST
 TEXT LINE) BOTTOM-LEFT-JUSTIFIED UNLESS OTHERWISE STATED.

- 212 F0) a) Insert the text string "SIMPLE" horizontally at
 (3.0,5.625,0.0).
- b) Insert the text string "SIMPLE" vertically at
 (4.0,6.0,0.0). Change the text slant 30 degrees
 clockwise from the vertical axis. Change the text
 width to 0.147 inches for this text string.
- 212 F1) Insert the text "DUAL" and "STACK" as one text string
 such that the words are both left justified and the
 second word is displayed below the first. Place the
 origin of the text at (5.0,5.625,0.0).
- 212 F2) a) Insert the text "IMBEDDED" with the origin of the
 text string at (7.0,5.625,0.0).
- b) Change the font of the middle three letters,
 "BED", of the text string to the IGES Font 1002.
 This will change the letters "BED" to the symbols
 " " " .
- 212 F3) Insert the text string "SSUPER" such that the origin is
 at (9.0,5.625,0.0) and the word "SUPER" is a
 superscript of "S".
- 212 F4) Insert the text string "SSUB" such that the origin is
 at (11.0,5.625,0.0) and the word "SUB" is a subscript
 of "S".

- 212 F5) Insert the text "S", "SUPER", and "SUB" as one text string such that the origin is at (13.0,5.625,0.0) and the word "SUPER" is a superscript of "S" and "SUB" is a subscript of "S".
- 212 F6) Insert the text "M", "STACK", and "LEFT" as one multi-lined text string such that the origin of the text string is at (15.0,5.75,0.0) and all words are left-justified to a common margin.
- 212 F7) Insert the text "M", "STACK", and "CENTER" as one multi-lined text string that is bottom-center-justified with the origin at (1.5,3.75,0.0).
- 212 F8) Insert the text "M", "STACK", and "RIGHT" as one multi-lined text string that is bottom-right-justified with the origin at (4.0,3.75,0.0).
- 212 F100) Insert a multi-lined text string that is bottom-left-justified with the origin at (5.0,3.5625,0.0) as follows:

```

      FRAC
S  ----
      TION

```

There are two spaces between the whole number part and the fractional part. The second string "FRAC" is a superscript of the first string "S", the third string "TION" is a subscript of the first string, and "----" is the fourth string.

- 212 F101) Insert a multi-lined text string with the origin of the first string at (7.0,3.8125,0.0) as follows:

```

      TO
DUAL ---
      P

      BOT
STACK ----
      TOM

```

There are two spaces between the whole number part and the fractional part. The second string "TO" is a superscript of the first string "DUAL", the third string "P" is a subscript of the first string, and "----" is the fourth string. The mixed numeral expression is positioned such that the fifth string "STACK" is displayed below the first string. The sixth string "BOT" is a superscript of the fifth string, and the seventh string is a subscript of the fifth string, and "----" is the eighth string.

212 F102) Insert a multi-lined text string with the origin at (8.65625,3.5625,0.0) as follows:

```

      BED          ACT
IM  ----  =  FR  ----
      DED          ION

```

There are two spaces between the whole number part and the fractional part. The second string "BED" is a superscript of the first string "IM", the third string "DED" is a subscript of the first string, and "----" is the fourth string. The fifth string " = " is a special character "i" using the IGES Font 1002. The mixed numeral is positioned such that the sixth string "FR" is displayed two spaces to the right of the fifth string. The seventh string "ACT" is a superscript of the fifth string, and the eighth string "ION" is a subscript of the fifth string, and "----" is the ninth string.

212 F105) Insert a multi-lined text string with the origin at (10.625,3.625,0.0) as follows:

```

          O
        T  ---
          P
      SUP
FR  ----
      SUB
          TT
        BO  ---
          OM

```

There are two spaces between the whole number part and the fractional part. The second string "SUP" is a superscript of the first string "FR", the third string "SUB" is a subscript of the first string, and "----" is the fourth string. The second mixed numeral is a superscript of the first, and consists of the following strings: The sixth string "O" is a superscript of the fifth string "T", and the seventh string "P" is a subscript of the fifth string, and "----" is the eighth string. The third mixed numeral is a subscript of the first, and consists of the following strings: The tenth string "TT" is a superscript of the ninth string "BO", the eleventh string "OM" is a subscript of the ninth string, and the twelfth string is "----"

- 230) a) Insert four lines from:
- | | | |
|----------------|----|-----------------|
| (13.0,3.0,0.0) | to | (14.0,3.0,0.0) |
| (14.0,3.0,0.0) | | (14.0,4.0,0.0) |
| (14.0,4.0,0.0) | | (13.0,4.0,0.0) |
| (13.0,4.0,0.0) | | (13.0,3.0,0.0). |
- b) Utilize the "sectioned area entity" (230) to crosshatch between the lines. The fill should be solid parallel line segments from section edge to edge. They should be angled 45 degrees counterclockwise from the x-axis and spaced 0.2 inches apart.
- 406 F18) Insert the text "SPACING" with its bottom-left-justified origin at (14.8,3.5,0.0). Each character shall be 0.125 high and 0.1 wide, the spacing between each character shall be 0.1. This is 80 percent of the character height.
- 308) Create a subfigure named "PERSON" of a shaped figure composed of five lines from:
- | | | |
|------------------|----|------------------------|
| (-0.125,0.0,0.0) | to | (0.0,0.25,0.0) |
| (0.0,0.25,0.0) | | (0.125,0.0,0.0) |
| (0.0,0.25,0.0) | | (0.0,0.4375,0.0) |
| (0.0,0.375,0.0) | | (0.09375,0.28125,0.0) |
| (0.0,0.375,0.0) | | (-0.09375,0.28125,0.0) |
- and a circle of radius 0.0625 centered at (0.0,0.5,0.0).
- 408) Insert the subfigure "PERSON" into the IENTITY model at the model location (1.5,1.5,0.0).
- 412) Insert a rectangular array subfigure of "PERSON" consisting of 2 columns and 2 rows. The bottom left corner of the array is at (3.0,1.0,0.0). The horizontal distance between columns is 1.0 and the vertical distance between rows is 0.75.
- 414) Insert a circular array subfigure of "PERSON" consisting of 3 instances centered at (5.5,1.5,0.0). The first instance is at a radius of 0.5 and an angle of 30 degrees, the other two instances are at an incremental angle of 120 degrees.

Incident Report

Attachment C

Procedures for Executing the CTN Reference
Illustration IGES Post-processor Test

Procedures for Executing the CTN Reference
Illustration IGES Post-processor Test.

1. Receive a 9-track, MIL-STD-1840A formatted tape from the CALS Test Network containing both the IENTITY and LGTABLE IGES files in MIL-D-28000 Class I format.
2. Read the MIL-STD-1840A declaration information and load the IGES files onto your graphics system storage. The file names are shown in the 1840A declaration files and header fields.
3. Read and then strip the MIL-STD-1840A headers from the IGES files.
4. Post-process the IGES files into your graphics system, noting all errors the system reports.
5. Inspect the resulting graphics and answer the questions listed in the evaluation scripts. If you answer "no" to any of the questions, please explain why on the incident report sheets which follow the script. Attach additional sheets if necessary.
6. Generate a hard copy plot of each illustration.
7. If you are conducting a self-test, collect the evaluation scripts, plots, and any incident reports for evaluation. If you pre-arranged a formal CTN test and obtained CTN approval, send the completed evaluation scripts, plots, and any incident reports to:

CALS Test Network, IGES Testing
Lawrence Livermore National Laboratory
P.O. Box 808, 7000 East Ave., L-542
Livermore, CA 94550

Refer questions to Jill Farrell at (415) 423-6348.

8. Evaluate the data. We at the CALS Test Network will and anyone conducting a self-test should:
 - a. Examine the incident reports, plots, and evaluation scripts.
 - b. Pinpoint processor, IGES standard, and/or military standard inefficiencies.
 - c. Bring the findings to the appropriate parties for correction (either vendor, graphics system operator, IGES Committee, or the military standard's sponsor).
 - d. CTN will publicly publish results of CTN findings.

Attachment D

IDENTITY Evaluation Script

IDENTITY Evaluation Script

Answer the following questions:

100)

- a) Is the circular arc centered at (1.5,9.5,0.0)?
- b) Is the arc radius 0.5 inches?
- c) Is the arc traced out from 270 to 180 degrees counterclockwise?

102)

- a) Is the composite curve made up of 2 lines and a spline?
- b) Does one line extend from (3.0,9.5,0.0) to (3.0,10.0,0.0)?
- c) Does the second line extend from (3.0,10.0,0.0) to (3.5,9.5,0.0)?
- d) Does the spline curve between the end points (3.5,9.5,0.0) and (4.25,9.25,0.0)?
- e) Does the composite curve behave as a single entity (selectable by one touch)?

104 Form 0)

- a) Is the general conic arc an ellipse centered at (5.5,9.5,0.0)?
- b) Is the major axis 1.0 inches?
- c) Is the minor axis 0.5 inches?
- d) Is the ellipse positioned so that the long axis parallels the vertical axis (is the ellipse skinny and tall)?

104 Form 1)

- a) Is the ellipse centered at (7.5,9.5,0.0)?
- b) Is the major axis 1.0 inches?
- c) Is the minor axis 0.5 inches?
- d) Is the ellipse positioned so that the long axis parallels the horizontal axis (is the ellipse short and fat)?

104 Form 2)

- a) Is the hyperbola a horizontal hyperbola (shaped like a backwards "C")?
- b) Is the right most part of the hyperbola at (9.5,9.5,0.0)?
- c) Do the ends of the hyperbola extend toward the negative x-direction 0.25 inches?
- d) Does the conic visually resemble the hyperbola on the IDENTITY plot?

104 Form 3)

- a) Is the parabola a vertical parabola (shaped like a wide "U")?
- b) Is the parabola's vertex (lowest point) at (11.5,9.5,0.0)?
- c) Do the ends of the parabola extend 0.25 inches into the positive y-direction?
- d) Does the conic visually resemble the parabola on the IENTITY plot?

106 Form 11)

- a) Does the linear planar curve look like a circular arc of radius 0.5 inches, centered at (13.5,9.25,0.0) and traced out from 0 to 180 degrees counterclockwise?
- b) Is the linear planar curve made up of short straight segments combined to form a single entity?

106 Form 63)

- a) Is a rectangle present between the points (15,9.25,0.0), (15.0,10.0,0.0), (16.0,10.0,0.0), and (16,9.25,0)?
- b) Is this rectangle a closed area (can it be filled by a pattern)?
- c) Does this simple closed area behave as a single entity (selectable by one touch)?

110)

Is a line present from (1.5,8.0,0.0) to (1.5,7.0,0.0)?

112)

- a) Does the spline start at the upper left near (3.0,8.0,0.0), trace out toward the lower right, move toward the lower left to create a loop, and cross back over itself as it moves to the upper right near (4.0,8.0,0.0)?
- b) Does the parametric spline curve visually resemble the spline on the IENTITY plot?

124 Form 0)

- a) Did a semi-circle appear?
- b) Is the semi-circle open toward the right side, in other words, is it shaped like a "C"?

126 Form 0)

- a) Does a rational b-spline curve pass through the points (7.0,7.0,0.0), (7.0,7.5,0.0), (7.0,8.0,0.0), (7.5,8.0,0.0), (8.0,8.0,0.0), (8.0,7.5,0.0), (8.0,7.0,0.0)?
- b) Does the rational b-spline curve visually resemble the curve on the IENTITY plot?

126 Form 1)

- _____ a) Does a rational b-spline curve pass through the points? (9.0,7.5,0.0), (10.0,8.0,0.0)? This curve approximates a line.
- _____ b) Does the rational b-spline curve visually resemble the curve on the IENTITY plot?

126 Form 2)

- _____ a) Place the following points on the illustration: (12.0,7.5,0.0), (11.9045,7.79389,0.0), (11.6545,7.97553,0.0), (11.3455,7.97553,0.0), (11.0955,7.79389,0.0), (11.0,7.5,0.0). Does the rational b-spline curve pass through these points? This curve approximates an arc.
- _____ b) Does the rational b-spline curve visually resemble the curve on the IENTITY plot?

126 Form 3)

- _____ a) Place the following points on the illustration: (14.0,7.5,0.0), (13.8528,7.67713,0.0), (13.6208,7.74259,0.0), (13.3792,7.74259,0.0), (13.1472,7.67713,0.0), (13.0,7.5,0.0). Does the rational b-spline curve pass through these points? This curve approximates an elliptical arc.
- _____ b) Does the rational b-spline curve visually resemble the curve on the IENTITY plot?

126 Form 4)

- _____ a) Place the following points on the illustration: (16.0,7.75,0.0), (15.8231,7.60439,0.0), (15.6138,7.51295,0.0), (15.3862,7.51295,0.0), (15.1769,7.60439,0.0), (15.0,7.75,0.0). Does the rational b-spline curve pass through these points? This curve approximates a parabolic arc.
- _____ b) Does the rational b-spline curve visually resemble the curve on the IENTITY plot?

126 Form 5)

- _____ a) Place the following points on the illustration: (1.25,5.71651,0.0), (1.36619,5.64544,0.0), (1.4722,5.56046,0.0), (1.47214,5.43958,0.0), (1.36622,5.35451,0.0), (1.25,5.28349,0.0). Does the rational b-spline curve pass through these points? This curve approximates an hyperbolic arc.
- _____ b) Does the rational b-spline curve visually resemble the curve on the IENTITY plot?

212 Form 0)

- a) Does the lower left corner of the horizontal text block "SIMPLE" reside at (3.0,5.625,0.0)?
- b) Does a second text string also say "SIMPLE"?
- c) Is this second text string vertical in orientation?
- d) Are the letters of this second text string slanted 30 degrees clockwise from the vertical axis?
- e) Is the lower left corner of the letter "S" at (4.0,6.0,0.0)?
- f) Is the text height for both text strings 0.125 inches?
- g) Does the vertical text have a wider character width than the horizontal text?

212 Form 1)

- a) Does the text say "DUAL STACK"?
- b) Is the lower left corner of the text "DUAL" at (5.0,5.625,0.0)?
- c) Is the text "STACK" left justified directly below "DUAL"?
- d) Is the text height 0.125 inches?
- e) Does the entire text string act as a single entity?

212 Form 2)

- a) Do the first and second letters say "IM" and the sixth through eighth say "DED"?
- b) Do the third through the fifth letters say " " " ?
- c) Is the lower left corner of the text block at (7.0,5.625,0.0)?
- d) Is the text height 0.125 inches?
- e) Does the entire text string act as a single entity?

212 Form 3)

- a) Are the words of the general note "S" and "SUPER"?
- b) Is the word "SUPER" a superscript of the letter "S"?
- c) Is the lower left corner of the letter "S" at (9.0,5.625,0.0)?
- d) Is the text height 0.125 inches?
- e) Does the entire text string act as a single entity?

212 Form 4)

- a) Are the words of the general note "S" and "SUB"?
- b) Is the word "SUB" a subscript of the letter "S"?
- c) Is the lower left corner of the letter "S" at (11.0,5.625,0.0)?
- d) Is the text height 0.125 inches?
- e) Does the entire text string act as a single entity?

212 Form 5)

- a) Are the words of the general note "S", "SUPER", and "SUB"?
- b) Is the word "SUPER" a superscript of "S"?
- c) Is the word "SUB" a subscript of "S"?
- d) Is the lower left corner of the letter "S" at (13.0,5.625,0.0)?
- e) Is the text height 0.125 inches?
- f) Does the entire text string act as a single entity?

212 Form 6)

- a) Are the words of the general note "M", "STACK", and "LEFT"?
- b) Are the words stacked one below the other ("M" then "STACK" then "LEFT")?
- c) Are the words left justified to a common margin?
- d) Is the lower left corner of the letter "M" at (15.0,5.75,0.0)?
- e) Is the text height 0.125 inches?
- f) Does the entire text string act as a single entity?

212 Form 7)

- a) Are the words of the general note "M", "STACK", and "CENTER"?
- b) Are the words stacked one below the other?
- c) Are the words center justified?
- d) Is the lower center location of the letter "M" at (1.5,3.75,0.0)?
- e) Is the text height 0.125 inches?
- f) Does the entire text string act as a single entity?

212 Form 8)

- a) Are the words of the general note "M", "STACK", and "RIGHT"?
- b) Are the words stacked one below the other?
- c) Are the words right justified to a common margin?
- d) Is the lower right corner of the letter "M" at (4.0,3.75,0.0)?
- e) Is the text height 0.125 inches?
- f) Does the entire text string act as a single entity?

212 Form 100)

- a) Does the text appear as shown?

FRAC
S ----
TION

- b) Is the lower left corner of the letter "S" at (5.07,3.56,0.0)?
- c) Does the entire text string act as a single entity?

212 Form 101)

_____ a) Does the text appear as shown?

 TO
DUAL ----
 P

 BOT
STACK ----
 TOM

_____ b) Is the lower left corner of "DUAL" at (7.0,3.81,0.0)?

_____ c) Does the entire text string act as a single entity?

212 Form 102)

_____ a) Does the text appear as shown?

 BED ACT
IM ---- = FR ----
 DED ION

_____ b) Is the lower left corner of "IM" at (8.66,3.56,0.0)?

_____ c) Does the entire text string act as a single entity?

212 Form 105)

_____ a) Does the text appear as shown?

 O
 T ---
 P
 SUP
FR ----
 SUB
 TT
 BO ---
 OM

_____ b) Is the lower left corner of "FR" at (10.625,3.625,0)?

_____ c) Does the entire text string act as a single entity?

230)

_____ a) Do four lines form a square?

_____ b) Is the square crosshatched with solid parallel line segments from edge to edge?

_____ c) Is the crosshatching spacing 0.2 inches?

_____ d) Is the crosshatching angled at 45 degrees?

406 F18)

- a) Does the text say "SPACING"?
- b) Is the lower left corner of the text at (14.8,3.5,0.0)?
- c) Is the text height 0.125 inches?
- d) Is the text width 0.1 inches?
- e) Is the spacing between each character 0.1 inches so that the text is unusually widely spaced?
- f) Does the text end at approximately (16.1,3.5,0.0)?

308)

- a) Does a subfigure named "PERSON" exist?
- b) Does the subfigure named "PERSON" consist of five lines from:
 - (-0.125,0.0,0.0) to (0.0,0.25,0.0)
 - (0.0,0.25,0.0) (0.125,0.0,0.0)
 - (0.0,0.25,0.0) (0.0,0.4375,0.0)
 - (0.0,0.375,0.0) (0.09375,0.28125,0.0)
 - (0.0,0.375,0.0) (-0.09375,0.28125,0.0)
- c) and a circle of radius 0.0625 centered at (0.0,0.5,0.0)?

408)

- a) Does an instance of "PERSON" appear with its origin at (1.5,1.5,0.0)? The origin of "PERSON" is a point exactly between the person's feet.

412)

- Does an instance of "PERSON" appear at:
- a) (3.0,1.0,0.0)?
 - b) (4.0,1.0,0.0)?
 - c) (3.0,1.75,0.0)?
 - d) (4.0,1.75,0.0)?

414) Does an instance of "PERSON" appear at:

- a) (5.933,1.75,0.0)?
- b) (5.067,1.75,0.0)?
- c) (5.5,1.0,0.0)?

Grid Lines)

- a) Are there 9 vertical grid lines?
- b) Are there 6 horizontal grid lines?

Entity Identifiers)

- Is every entity identified by a name and an IGES number placed beneath the entity within the grid box?

Title Block)

- Does the title block in the lower right hand grid box say,
"CALSTEST NETWORK
MIL-D-28000
CLASS I
REFERENCE DRAWING
I-ENTITY"?

Incident Report

Attachment E

LGTABLE Evaluation Notes

LGTABLE Evaluation Notes

_____ Does the post-processed illustration visually resemble the plot of the LGTABLE illustration?





















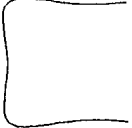

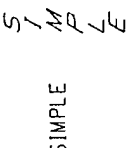

Things to look for:

- * Solid fill in circles in table
- * Solid fill in arrowheads
- * Dashed lines between circles in table
- * Properly justified text in tables
- * Correct arc and conic orientations around airplane wheel
- * Relative line thicknesses
- * Text "CALs Test Network LGTABLE Reference Illustration" in lower right hand corner of illustration

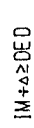
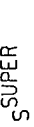
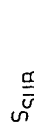
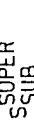
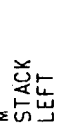
Incident Report

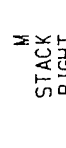
Attachment F

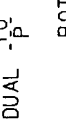
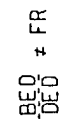
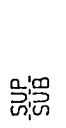
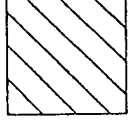
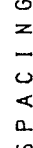
IDENTITY B-sized Plot

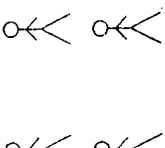
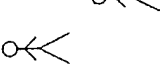
	CIRCULAR ARC (100)		COMPOSITE CURVE (102)		CONIC ARC - GENERAL (104 FORM 0)		CONIC ARC - ELLIPSE (104 FORM 1)		CONIC ARC - HYPERBOLA (104 FORM 2)		CONIC ARC - PARABOLA (104 FORM 3)		LINEAR PLANAR CURVE (106 FORM 1)		SIMPLE CLOSED AREA (106 FORM 63)
	LINE (110)		PARAMETRIC SPLINE CURVE (112)		TRANSFORMATION MATRIX (114 FORM 0)		RATIONAL B-SPLINE CURVE (126 FORM 0)		RATIONAL B-SPLINE CURVE LINE (126 FORM 1)		RATIONAL B-SPLINE CURVE CIRCULAR ARC (126 FORM 2)		RATIONAL B-SPLINE CURVE ELLIPTICAL ARC (126 FORM 3)		RATIONAL B-SPLINE CURVE PARABOLIC ARC (126 FORM 4)
	RATIONAL B-SPLINE CURVE HYPERBOLIC ARC (126 FORM 5)		SIMPLE (GENERAL NOTE - SIMPLE (127 FORM 0))		DUAL STACK (NOTE - DUAL STACK (127 FORM 1))		IM+>DED (NOTE - IMBEDDED FONT CHANGE (127 FORM 2))		S-SUPER (NOTE - SUPERScript (127 FORM 3))		S-SUB (NOTE - SUBSCRIPT (127 FORM 4))		SUPER (NOTE - SUPER/SUBSCRIPT (127 FORM 5))		M-STACK LEFT (NOTE - MULTI STACK LEFT JUST (127 FORM 6))
	M-STACK CENTER (NOTE - MULTI STACK CENT. JUST (127 FORM 7))		M-STACK RIGHT (NOTE - MULTI STACK RIGHT JUST (127 FORM 8))		S-FRAC STATION (NOTE - SIMPLE FRACTION (127 FORM 100))		DUAL TO P BOT TOM (NOTE - DUAL STACK FRACTION (127 FORM 101))		IM BED ≠ FR ACTION (NOTE - FONT/DOUBLE FRACTION (127 FORM 102))		FR SUP SUB BO OM (NOTE - SUPER/SUB FRACTION (127 FORM 105))		SECTIONED AREA (1230)		SPACING (INTERCHARACTER SPACING (1406 FORM 1B))
	SINGLE SUBFIGURE INSTANCE (1401)		RECTANGULAR SUBFIGURE INSTANCE (1412)		CIRCULAR SUBFIGURE INSTANCE (1414)										CALS TEST NETWORK MIL-D-28000 CLASS REFERENCE DRAWING 1-ENTITY

Attachment G

LGTABLE A-sized Plot

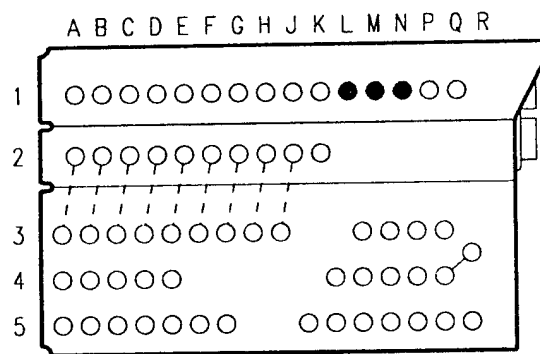
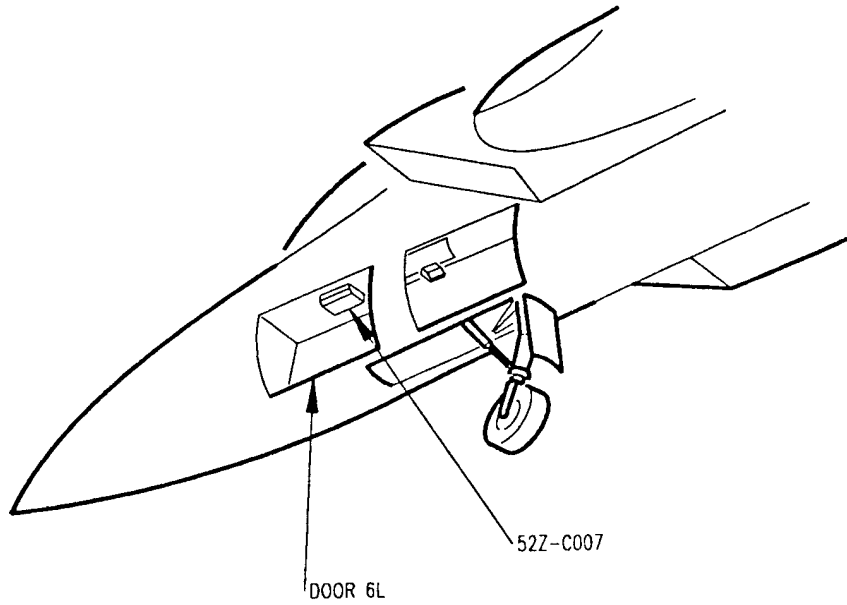

52Z-C007

52Z-C007		ESSENTIAL CIRCUIT BREAKER PANEL NO. 1		(24-50-12)
REF DES	ZONE	NOMENCLATURE		BUS
41CBC033	L1	R MLG WOW PWR	28VDC	ESS 28VDC
41CBC034	M1	L MLG WOW PWR	28VDC	ESS 28VDC
42CBC005	N1	LDG GR POS IND	28VDC	ESS 28VDC

Attachment H

IDENTITY IGES File Printout

0			1						D	48
0	25								D	49
0			1						D	50
0	26								D	51
0			1						D	52
0	27								D	53
0			1						D	54
410	28	1	0	0	0	0	0	20101D	55	
410	0	0	1	0				D	56	
110	29	1	1	0	0	0	0	10001D	57	
110	0	2	1	0				D	58	
110	30	1	1	0	0	0	0	10001D	59	
110	0	2	1	0				D	60	
124	31	1	0	0	0	0	0	1D	61	
124	0	0	1	0				D	62	
104	32	1	1	0	0	61	0	1D	63	
104	0	2	1	2				D	64	
124	33	1	0	0	0	0	0	1D	65	
124	0	0	1	0				D	66	
104	34	1	1	0	0	65	0	1D	67	
104	0	2	1	3				D	68	
124	35	1	0	0	0	0	0	1D	69	
124	0	0	1	0				D	70	
104	36	1	1	0	0	69	0	1D	71	
104	0	2	1	0				D	72	
110	37	1	1	0	0	0	0	1D	73	
110	0	2	1	0				D	74	
124	38	1	0	0	0	0	0	1D	75	
124	0	0	1	0				D	76	
104	39	1	1	0	0	75	0	1D	77	
104	0	2	1	1				D	78	
100	40	1	1	0	0	0	0	1D	79	
100	0	2	1	0				D	80	
110	41	1	1	0	0	0	0	10001D	81	
110	0	2	1	0				D	82	
110	42	1	1	0	0	0	0	10001D	83	
110	0	2	1	0				D	84	
110	43	1	1	0	0	0	0	10001D	85	
110	0	2	1	0				D	86	
110	44	1	1	0	0	0	0	10001D	87	
110	0	2	1	0				D	88	
110	45	1	1	0	0	0	0	1D	89	
110	0	2	1	0				D	90	
110	46	1	1	0	0	0	0	1D	91	
110	0	2	1	0				D	92	
110	47	1	1	0	0	0	0	1D	93	
110	0	2	1	0				D	94	
110	48	1	1	0	0	0	0	1D	95	
110	0	2	1	0				D	96	
110	49	1	1	0	0	0	0	1D	97	
110	0	2	1	0				D	98	
110	50	1	1	0	0	0	0	1D	99	
110	0	2	1	0				D	100	
110	51	1	1	0	0	0	0	1D	101	
110	0	2	1	0				D	102	
110	52	1	1	0	0	0	0	1D	103	
110	0	2	1	0				D	104	
110	53	1	1	0	0	0	0	1D	105	
110	0	2	1	0				D	106	
110	54	1	1	0	0	0	0	1D	107	
110	0	2	1	0				D	108	
110	55	1	1	0	0	0	0	1D	109	
110	0	2	1	0				D	110	
110	56	1	1	0	0	0	0	1D	111	
110	0	2	1	0				D	112	
110	57	1	1	0	0	0	0	1D	113	

110	0	2	1	0					D	114
110	58	1	1	0	0	0	0	0	1D	115
110	0	2	1	0					D	116
110	59	1	1	0	0	0	0	0	1D	117
110	0	2	1	0					D	118
0	60								D	119
0			1						D	120
0	61								D	121
0			1						D	122
0	62								D	123
0			1						D	124
0	63								D	125
0			1						D	126
0	64								D	127
0			1						D	128
0	65								D	129
0			1						D	130
0	66								D	131
0			1						D	132
0	67								D	133
0			1						D	134
0	68								D	135
0			1						D	136
106	69	1	1	0	0	0	0	0	1D	137
106	0	2	8	11					D	138
106	77	1	1	0	0	0	0	0	1D	139
106	0	2	1	63					D	140
112	78	1	1	0	0	0	0	0	10001D	141
112	0	2	4	0					D	142
112	82	1	1	0	0	0	0	0	1D	143
112	0	2	14	0					D	144
126	96	1	1	0	0	0	0	0	1D	145
126	0	2	2	1					D	146
126	98	1	1	0	0	0	0	0	1D	147
126	0	2	4	2					D	148
126	102	1	1	0	0	0	0	0	1D	149
126	0	2	5	0					D	150
126	107	1	1	0	0	0	0	0	1D	151
126	0	2	4	3					D	152
126	111	1	1	0	0	0	0	0	1D	153
126	0	2	2	4					D	154
126	113	1	1	0	0	0	0	0	1D	155
126	0	2	4	5					D	156
102	117	1	1	0	0	0	0	0	10201D	157
102	0	0	1	0					D	158
230	118	1	1	0	0	0	0	0	101D	159
230	0	2	1	0					D	160
212	119	1	0	0	0	0	0	0	101D	161
212	0	2	1	0					D	162
212	120	1	0	0	0	0	0	0	101D	163
212	0	2	9	102					D	164
212	129	1	0	0	0	0	0	0	101D	165
212	0	2	12	105					D	166
212	141	1	0	0	0	0	0	0	101D	167
212	0	2	8	101					D	168
212	149	1	0	0	0	0	0	0	101D	169
212	0	2	4	100					D	170
212	153	1	0	0	0	0	0	0	101D	171
212	0	2	3	8					D	172
212	156	1	0	0	0	0	0	0	101D	173
212	0	2	3	7					D	174
212	159	1	0	0	0	0	0	0	101D	175
212	0	2	3	6					D	176
212	162	1	0	0	0	0	0	0	101D	177
212	0	2	3	5					D	178
212	165	1	0	0	0	0	0	0	101D	179

212	0	2	2	0				D	180
212	167	1	0	0	0	0	0	101D	181
212	0	2	3	0				D	182
212	170	1	0	0	0	0	0	101D	183
212	0	2	3	0				D	184
212	173	1	0	0	0	0	0	101D	185
212	0	2	3	0				D	186
212	176	1	0	0	0	0	0	101D	187
212	0	2	3	0				D	188
212	179	1	0	0	0	0	0	101D	189
212	0	2	3	0				D	190
212	182	1	0	0	0	0	0	101D	191
212	0	2	3	0				D	192
212	185	1	0	0	0	0	0	101D	193
212	0	2	3	0				D	194
212	188	1	0	0	0	0	0	101D	195
212	0	2	3	0				D	196
212	191	1	0	0	0	0	0	101D	197
212	0	2	3	0				D	198
212	194	1	0	0	0	0	0	101D	199
212	0	2	3	0				D	200
212	197	1	0	0	0	0	0	101D	201
212	0	2	3	0				D	202
212	200	1	0	0	0	0	0	101D	203
212	0	2	2	0				D	204
212	202	1	0	0	0	0	0	101D	205
212	0	2	3	0				D	206
212	205	1	0	0	0	0	0	101D	207
212	0	2	3	0				D	208
212	208	1	0	0	0	0	0	101D	209
212	0	2	3	0				D	210
212	211	1	0	0	0	0	0	101D	211
212	0	2	3	0				D	212
212	214	1	0	0	0	0	0	101D	213
212	0	2	3	0				D	214
212	217	1	0	0	0	0	0	101D	215
212	0	2	3	0				D	216
212	220	1	0	0	0	0	0	101D	217
212	0	2	2	0				D	218
212	222	1	0	0	0	0	0	101D	219
212	0	2	2	0				D	220
212	224	1	0	0	0	0	0	101D	221
212	0	2	1	0				D	222
212	225	1	0	0	0	0	0	101D	223
212	0	2	3	0				D	224
212	228	1	0	0	0	0	0	101D	225
212	0	2	3	0				D	226
212	231	1	0	0	0	0	0	101D	227
212	0	2	3	0				D	228
212	234	1	0	0	0	0	0	101D	229
212	0	2	3	0				D	230
212	237	1	0	0	0	0	0	101D	231
212	0	2	3	0				D	232
212	240	1	0	0	0	0	0	101D	233
212	0	2	3	0				D	234
212	243	1	0	0	0	0	0	101D	235
212	0	2	3	0				D	236
212	246	1	0	0	0	0	0	101D	237
212	0	2	3	0				D	238
212	249	1	0	0	0	0	0	101D	239
212	0	2	3	0				D	240
212	252	1	0	0	0	0	0	101D	241
212	0	2	6	0				D	242
212	258	1	0	0	0	0	0	101D	243
212	0	2	3	2				D	244
212	261	1	0	0	0	0	0	101D	245

212	0	2	2	4				D	246
212	263	1	0	0	0	0	0	101D	247
212	0	2	2	3				D	248
212	265	1	0	0	0	0	0	101D	249
212	0	2	2	1				D	250
212	267	1	0	0	0	0	0	101D	251
212	0	2	3	0				D	252
212	270	1	0	0	0	0	0	101D	253
212	0	2	3	0				D	254
212	273	1	0	0	0	0	0	101D	255
212	0	2	3	0				D	256
212	276	1	0	0	0	0	0	101D	257
212	0	2	3	0				D	258
212	279	1	0	0	0	0	0	101D	259
212	0	2	3	0				D	260
212	282	1	0	0	0	0	0	101D	261
212	0	2	3	0				D	262
408	285	1	1	0	0	0	0	1D	263
408	0	0	1	0				D	264
0	286							D	265
0			1					D	266
0	287							D	267
0			1					D	268
0	288							D	269
0			1					D	270
0	289							D	271
0			1					D	272
0	290							D	273
0			1					D	274
0	291							D	275
0			1					D	276
0	292							D	277
0			1					D	278
102	293	1	1	0	0	0	0	201D	279
102	0	0	1	0				D	280
0	294	1	0	0	0	0	0	10201D	281
0	0	0	1	0				D	282
0	295	1	0	0	0	0	0	10201D	283
0	0	0	1	0				D	284
406	296	1	0	0	0	0	0	20001D	285
406	0	0	1	16				D	286
404	297	1	0	0	0	0	0	101D	287
404	0	0	1	0				D	288
406	298	0	1	0	0	0	0	20001D	289
406	0	0	1	18				D	290
412	299	1	1	0	0	0	0	1D	291
412	0	0	1	0				D	292
414	300	1	1	0	0	0	0	1D	293
414	0	0	1	0				D	294
100	301	1	1	0	0	37	0	1D	295
100	0	2	1	0				D	296
0;								1P	1
0;								3P	2
0;								5P	3
0;								7P	4
0;								9P	5
0;								11P	6
0;								13P	7
110,-0.125,0.0,0.0,0.0,0.25,0.0;								15P	8
110,0.0,0.25,0.0,0.125,0.0,0.0;								17P	9
110,0.0,0.25,0.0,0.0,0.4375,0.0;								19P	10
110,0.0,0.375,0.0,0.09375,0.28125,0.0;								21P	11
110,0.0,0.375,0.0,-0.09375,0.28125,0.0;								23P	12
100,0.0,0.0,0.5,0.0625,0.5,0.0625,0.5;								25P	13
308,0,6HPERSON,6,13,15,17,19,21,23;								27P	14
0;								29P	15
0;									

0;	31P	16
0;	33P	17
0;	35P	18
124,0.0,1.0,0.0,5.5,-1.0,0.0,0.0,7.5,0.0,0.0,1.0,0.0;	37P	19
0;	39P	20
0;	41P	21
0;	43P	22
0;	45P	23
0;	47P	24
0;	49P	25
0;	51P	26
0;	53P	27
410,5,1.0,0,0,0,0,0,0;	55P	28
110,3.0,10.0,0.0,3.5,9.5,0.0;	57P	29
110,3.0,9.5,0.0,3.0,10.0,0.0;	59P	30
124,-1.0,0.0,0.0,9.75,0.0,-1.0,0.0,9.5,0.0,0.0,1.0,0.0;	61P	31
104,16.0,0.0,-64.0,0.0,0.0,-1.0,0.0,0.5,-0.216506,0.5,0.216506;	63P	32
124,0.0,-1.0,0.0,11.5,1.0,0.0,0.0,9.5,0.0,0.0,1.0,0.0;	65P	33
104,0.0,0.0,1.0,-1.0,0.0,0.0,0.0,0.25,-0.5,0.25,0.5;	67P	34
124,0.0,-1.0,0.0,5.5,1.0,0.0,0.0,9.5,0.0,0.0,1.0,0.0;	69P	35
104,0.0625,0.0,0.25,0.0,0.0,-0.015625,0.0,0.0,-0.25,0.0,-0.25;	71P	36
110,1.5,8.0,0.0,1.5,7.0,0.0;	73P	37
124,1.0,0.0,0.0,7.5,0.0,1.0,0.0,9.5,0.0,0.0,1.0,0.0;	75P	38
104,0.0625,0.0,0.25,0.0,0.0,-0.015625,0.0,0.5,0.0,0.5,0.0;	77P	39
100,0.0,1.5,9.5,1.5,9.0,1.0,9.5;	79P	40
110,13.0,3.0,0.0,13.0,4.0,0.0;	81P	41
110,13.0,4.0,0.0,14.0,4.0,0.0;	83P	42
110,14.0,4.0,0.0,14.0,3.0,0.0;	85P	43
110,14.0,3.0,0.0,13.0,3.0,0.0;	87P	44
110,0.5,0.5,0.0,16.5,0.5,0.0;	89P	45
110,0.5,2.5,0.0,16.5,2.5,0.0;	91P	46
110,0.5,4.5,0.0,16.5,4.5,0.0;	93P	47
110,0.5,6.5,0.0,16.5,6.5,0.0;	95P	48
110,0.5,8.5,0.0,16.5,8.5,0.0;	97P	49
110,0.5,10.5,0.0,16.5,10.5,0.0;	99P	50
110,0.5,0.5,0.0,0.5,10.5,0.0;	101P	51
110,2.5,0.5,0.0,2.5,10.5,0.0;	103P	52
110,4.5,0.5,0.0,4.5,10.5,0.0;	105P	53
110,6.5,0.5,0.0,6.5,10.5,0.0;	107P	54
110,8.5,0.5,0.0,8.5,10.5,0.0;	109P	55
110,10.5,0.5,0.0,10.5,10.5,0.0;	111P	56
110,12.5,0.5,0.0,12.5,10.5,0.0;	113P	57
110,14.5,0.5,0.0,14.5,10.5,0.0;	115P	58
110,16.5,0.5,0.0,16.5,10.5,0.0;	117P	59
0;	119P	60
0;	121P	61
0;	123P	62
0;	125P	63
0;	127P	64
0;	129P	65
0;	131P	66
0;	133P	67
0;	135P	68
106,1,26,0.0,14.0,9.25,13.9961,9.3127,13.9843,9.3743,	137P	69
13.9649,9.4341,13.9382,9.4909,13.9045,9.5439,	137P	70
13.8645,9.5923,13.8187,9.6353,13.7679,9.6722,	137P	71
13.7129,9.7024,13.6545,9.7255,13.5937,9.7411,	137P	72
13.5314,9.749,13.4686,9.749,13.4063,9.7411,13.3455,	137P	73
9.7255,13.2871,9.7024,13.2321,9.6722,13.1813,9.6353,	137P	74
13.1355,9.5923,13.0955,9.5439,13.0618,9.4909,	137P	75
13.0351,9.4341,13.0157,9.3743,13.0039,9.3127,13.0,9.25;	137P	76
106,1,5,0.0,15.0,10.0,16.0,10.0,16.0,9.25,15.0,9.25,15.0,10.0;	139P	77
112,3,1,2,2,0.0,1.0,2.0,3.5,0.5625,0.0,-0.0625,9.5,-0.3125,	141P	78
0.0,0.0625,0.0,0.0,0.0,0.0,4.0,0.375,-0.1875,0.0625,	141P	79
9.25,-0.125,0.1875,-0.0625,0.0,0.0,0.0,0.0,4.25,0.1875,0.0,	141P	80
0.375,9.25,0.0625,0.0,-0.375,0.0,0.0,0.0,0.0;	141P	81

112,3,1,2,8,0.0,1.0,2.0,3.0,4.0,5.0,6.0,7.0,8.0,3.0,0.870858,	143P	82
0.0,-0.120858,8.0,-0.249075,0.0,0.0,0.0,0.0,	143P	83
0.0,0.0,3.75,0.508284,-0.362575,0.10429,7.75,-0.251843,	143P	84
0.0,0.0,0.0,0.0,0.0,0.0,4.0,0.0960054,	143P	85
-0.0497036,-0.0463009,7.5,-0.243556,0.0110455,-0.0174891,0.0,	143P	86
0.0,0.0,0.0,4.0,-0.142304,-0.188606,0.0809104,7.25,-0.273932,	143P	87
-0.0414219,0.065354,0.0,0.0,0.0,0.0,3.75,-0.276786,0.0541248,	143P	88
-0.0273387,7.0,-0.160714,0.15464,0.0,0.0,0.0,0.0,0.0,	143P	89
3.5,-0.250552,-0.0278912,0.0284429,7.0,0.16679,0.172863,	143P	90
-0.0896533,0.0,0.0,0.0,0.0,3.25,-0.221006,0.0574377,0.163568,	143P	91
7.25,0.243557,-0.0960965,0.10254,0.0,0.0,0.0,3.25,0.384573,	143P	92
0.548141,-0.182714,7.5,0.358985,0.211525,-0.0705097,0.0,0.0,0.0,	143P	93
0.0,4.0,0.932714,0.0,-1.09628,8.0,0.570505,	143P	94
0.0,-0.423058,0.0,0.0,0.0,0.0,	143P	95
126,1,1,1,0,1,0,0,0,0,1.0,1.0,1.0,1.0,9.0,7.5,0.0,10.0,8.0,	145P	96
0.0,0.0,1.0,0.0,0.0,1.0,	145P	97
126,5,5,1,0,1,0,0,0,0,0,0,0,0,0,0,1.0,1.0,1.0,1.0,1.0,1.0,	147P	98
1.0,1.0,1.0,1.0,1.0,1.0,12.0,7.5,0.0,12.0,7.8341,0.0,11.721,	147P	99
8.13295,0.0,11.279,8.13295,0.0,11.0,7.8341,0.0,11.0,7.5,0.0,0.0,	147P	100
1.0,0.0,0.0,1.0,	147P	101
126,8,3,1,0,1,0,0,0,0,0,0,0,0,1.0,2.0,3.0,4.0,5.0,6.0,6.0,6.0,	149P	102
6.0,1.0,1.0,1.0,1.0,1.0,1.0,1.0,1.0,1.0,7.0,7.0,0.0,7.01111,	149P	103
7.15385,0.0,7.03333,7.46154,0.0,6.86667,8.15385,0.0,7.5,7.92308,	149P	104
0.0,8.13333,8.15385,0.0,7.96667,7.46154,0.0,7.98889,7.15385,0.0,	149P	105
8.0,7.0,0.0,0.0,6.0,0.0,0.0,1.0,	149P	106
126,5,5,1,0,1,0,0,0,0,0,0,0,0,0,0,1.0,1.0,1.0,1.0,1.0,1.0,	151P	107
1.0,1.0,1.0,1.0,1.0,1.0,1.0,14.0,7.5,0.0,14.0,7.66705,0.0,13.721,	151P	108
7.81647,0.0,13.279,7.81647,0.0,13.0,7.66705,0.0,13.0,7.5,0.0,	151P	109
0.0,1.0,0.0,0.0,1.0,	151P	110
126,2,2,1,0,1,0,0,0,0,0,0,0,0,1.0,1.0,1.0,1.0,1.0,1.0,16.0,7.75,	153P	111
0.0,15.5,7.25,0.0,15.0,7.75,0.0,0.0,1.0,0.0,0.0,1.0,	153P	112
126,6,6,1,0,1,0,0,0,0,0,0,0,0,0,0,0,0,1.0,1.0,1.0,1.0,1.0,	155P	113
1.0,1.0,1.0,1.0,1.0,1.0,1.0,1.0,1.0,1.25,5.71651,0.0,1.49816,	155P	114
5.57323,0.0,1.52537,5.52714,0.0,1.49104,5.50133,0.0,1.51981,	155P	115
5.4700,0.0,1.5040,5.4302,0.0,1.25,5.2835,0.0,0.0,1.0,0.0,0.0,1.;	155P	116
102,4,81,83,85,87;	157P	117
230,157,1,13.7172,2.99,0.0,0.2,0.785385,0;	159P	118
212,1,6,1.0,0.125,1,1.0461,4.71,0,1,4.0,6.0,0.0,6HSIMPLE;	161P	119
212,9,2,0.22,0.125,1,1.5708,0.0,0,0,8.65625,3.5625,0.0,2HIM,	163P	120
3,0.35,0.125,1,1.5708,0.0,0,0,9.03125,3.65625,0.0,3HBED,	163P	121
3,0.34,0.125,1,1.5708,0.0,0,0,9.03125,3.46875,0.0,3HDED,	163P	122
4,0.44,0.125,1,1.5708,0.0,0,0,8.96875,3.5625,0.0,4H----	163P	123
1,0.1,0.125,1002,1.5708,0.0,0,0,9.53125,3.5625,0.0,1Hi,	163P	124
2,0.24,0.125,1,1.5708,0.0,0,0,9.71875,3.5625,0.0,2HFR,	163P	125
3,0.35,0.125,1,1.5708,0.0,0,0,10.0938,3.65625,0.0,3HACT,	163P	126
3,0.32,0.125,1,1.5708,0.0,0,0,10.0938,3.46875,0.0,3HION,	163P	127
4,0.44,0.125,1,1.5708,0.0,0,0,10.0313,3.5625,0.0,4H----	163P	128
212,12,2,0.24,0.125,1,1.5708,0.0,0,0,10.625,3.625,0.0,2HFR,	165P	129
3,0.34,0.125,1,1.5708,0.0,0,0,11.0313,3.71875,0.0,3HSUP,	165P	130
3,0.35,0.125,1,1.5708,0.0,0,0,11.0313,3.53125,0.0,3HSUB,	165P	131
4,0.44,0.125,1,1.5708,0.0,0,0,10.9688,3.625,0.0,4H----	165P	132
1,0.12,0.125,1,1.5708,0.0,0,0,11.4375,4.1875,0.0,1HT,	165P	133
1,0.12,0.125,1,1.5708,0.0,0,0,11.8125,4.28125,0.0,1HO,	165P	134
1,0.11,0.125,1,1.5708,0.0,0,0,11.8125,4.09375,0.0,1HP,	165P	135
3,0.33,0.125,1,1.5708,0.0,0,0,11.6875,4.1875,0.0,3H---	165P	136
2,0.24,0.125,1,1.5708,0.0,0,0,11.4375,3.0625,0.0,2HBO,	165P	137
2,0.24,0.125,1,1.5708,0.0,0,0,11.7813,3.15625,0.0,2HTT,	165P	138
2,0.26,0.125,1,1.5708,0.0,0,0,11.7813,2.96875,0.0,2HOM,	165P	139
3,0.33,0.125,1,1.5708,0.0,0,0,11.75,3.0625,0.0,3H---	165P	140
212,8,4,0.46,0.125,1,1.5708,0.0,0,0,7.0,3.8125,0.0,4HDUAL,	167P	141
2,0.24,0.125,1,1.5708,0.0,0,0,7.625,3.90625,0.0,2HTO,	167P	142
1,0.11,0.125,1,1.5708,0.0,0,0,7.6875,3.71875,0.0,1HP,	167P	143
3,0.33,0.125,1,1.5708,0.0,0,0,7.5625,3.8125,0.0,3H---	167P	144
5,0.56,0.125,1,1.5708,0.0,0,0,7.0,3.25,0.0,5HSTACK,	167P	145
3,0.36,0.125,1,1.5708,0.0,0,0,7.6875,3.34375,0.0,3HBOT,	167P	146
3,0.38,0.125,1,1.5708,0.0,0,0,7.6875,3.15625,0.0,3HTOM,	167P	147

4,0.44,0.125,1,1.5708,0.0,0,0,7.65625,3.25,0.0,4H----	167P	148
212,4,1,0.1133,0.125,1,1.5708,0.0,0,0,5.0742,3.5625,0.0,1HS,	169P	149
4,0.47,0.125,1,1.5708,0.0,0,0,5.1875,3.65625,0.0,4HFRAC,	169P	150
4,0.44,0.125,1,1.5708,0.0,0,0,5.1875,3.46875,0.0,4HTION,	169P	151
4,0.44,0.125,1,1.5708,0.0,0,0,5.1875,3.5625,0.0,4H----	169P	152
212,3,1,0.1162,0.125,1,1.5708,0.0,0,0,3.8833,3.75,0.0,1HM,5,	171P	153
0.5376,0.125,1,1.5708,0.0,0,0,3.46,3.5625,0.0,5HSTACK,5,0.5184,	171P	154
0.125,1,1.5708,0.0,0,0,3.48167,3.375,0.0,5HRIGHT;	171P	155
212,3,1,0.1162,0.125,1,1.5708,0.0,0,0,1.44167,3.75,0.0,1HM,5,	173P	156
0.5376,0.125,1,1.5708,0.0,0,0,1.23,3.5625,0.0,5HSTACK,6,0.648,	173P	157
0.125,1,1.5708,0.0,0,0,1.1775,3.375,0.0,6HCENTER;	173P	158
212,3,1,0.1162,0.125,1,1.5708,0.0,0,0,15.0,5.75,0.0,1HM,5,	175P	159
0.5376,0.125,1,1.5708,0.0,0,0,15.0,5.5625,0.0,5HSTACK,4,0.4224,	175P	160
0.125,1,1.5708,0.0,0,0,15.0,5.375,0.0,4HLEFT;	175P	161
212,3,1,0.1133,0.125,1,1.5708,0.0,0,0,13.0,5.625,0.0,1HS,5,	177P	162
0.5568,0.125,1,1.5708,0.0,0,0,13.1133,5.71875,0.0,5HSUPER,3,	177P	163
0.343,0.125,1,1.5708,0.0,0,0,13.1133,5.53125,0.0,3HSUB;	177P	164
212,2,14,1.099,0.07,1,1.5708,0.0,0,0,12.9505,2.74,0.0,14HSECTION	179P	165
ED AREA,5,0.308,0.07,1,1.5708,0.0,0,0,13.346,2.635,0.0,5H(230);	179P	166
212,2,16,1.26,0.07,1,1.5708,0.0,0,0,10.87,2.75,0.0,16HNOTE - SUP	181P	167
ER/SUB,23,1.652,0.07,1,1.5708,0.0,0,0,10.674,2.645,0.0,23HFRACTI	181P	168
ON (212 FORM 105);	181P	169
212,2,18,1.442,0.07,1,1.5708,0.0,0,0,8.779,2.75,0.0,18HNOTE - FO	183P	170
NT/DOUBLE,23,1.645,0.07,1,1.5708,0.0,0,0,8.6775,2.645,0.0,23HFRA	183P	171
CTION (212 FORM 102);	183P	172
212,2,17,1.316,0.07,1,1.5708,0.0,0,0,6.842,2.75,0.0,17HNOTE - DU	185P	173
AL STACK,23,1.624,0.07,1,1.5708,0.0,0,0,6.688,2.645,0.0,23HFRACT	185P	174
ION (212 FORM 101);	185P	175
212,2,13,1.015,0.07,1,1.5708,0.0,0,0,4.9925,2.75,0.0,13HNOTE - S	187P	176
IMPLE,23,1.652,0.07,1,1.5708,0.0,0,0,4.674,2.645,0.0,23HFRACTION	187P	177
(212 FORM 100);	187P	178
212,2,18,1.4,0.07,1,1.5708,0.0,0,0,2.8,2.75,0.0,18HNOTE - MULTI	189P	179
STACK,23,1.652,0.07,1,1.5708,0.0,0,0,2.674,2.645,0.0,23HRIGHT JU	189P	180
ST (212 FORM 8);	189P	181
212,2,18,1.4,0.07,1,1.5708,0.0,0,0,0.8,2.75,0.0,18HNOTE - MULTI	191P	182
STACK,22,1.603,0.07,1,1.5708,0.0,0,0,0.698501,2.645,0.0,22HCENT	191P	183
JUST (212 FORM 7);	191P	184
212,2,18,1.4,0.07,1,1.5708,0.0,0,0,14.8,4.75,0.0,18HNOTE - MULTI	193P	185
STACK,22,1.603,0.07,1,1.5708,0.0,0,0,14.6985,4.645,0.0,22HLEFT	193P	186
JUST (212 FORM 6);	193P	187
212,2,16,1.26,0.07,1,1.5708,0.0,0,0,12.87,4.75,0.0,16HNOTE - SUP	195P	188
ER/SUB,19,1.351,0.07,1,1.5708,0.0,0,0,12.8245,4.645,0.0,19HSCRIP	195P	189
T (212 FORM 5);	195P	190
212,2,21,1.652,0.07,1,1.5708,0.0,0,0,2.674,4.75,0.0,21HGENERAL N	197P	191
OTE - SIMPLE,12,0.826,0.07,1,1.5708,0.0,0,0,3.087,4.645,0.0,12H(197P	192
212 FORM 0);	197P	193
212,2,14,1.141,0.07,1,1.5708,0.0,0,0,4.9295,6.75,0.0,14HTRANSFOR	199P	194
MATION,23,1.617,0.07,1,1.5708,0.0,0,0,4.6915,6.645,0.0,23HMATRIX	199P	195
D=1 (124 FORM 0);	199P	196
212,2,17,1.33,0.07,1,1.5708,0.0,0,0,2.835,6.75,0.0,17HPARAMETRIC	201P	197
SPLINE,11,0.728,0.07,1,1.5708,0.0,0,0,3.136,6.645,0.0,11HCURVE	201P	198
(112);	201P	199
212,1,10,0.63,0.07,1,1.5708,0.0,0,0,1.185,6.75,0.0,10HLINE (110)	203P	200
;	203P	201
212,2,18,1.414,0.07,1,1.5708,0.0,0,0,14.793,8.75,0.0,18HSIMPLE C	205P	202
LOSED AREA,13,0.917,0.07,1,1.5708,0.0,0,0,15.0415,8.645,0.0,13H(205P	203
106 FORM 63);	205P	204
212,2,19,1.491,0.07,1,1.5708,0.0,0,0,12.7545,8.75,0.0,19HLINEAR	207P	205
PLANAR CURVE,13,0.861,0.07,1,1.5708,0.0,0,0,13.0695,8.645,0.0,	207P	206
13H(106 FORM 11);	207P	207
212,2,20,1.547,0.07,1,1.5708,0.0,0,0,10.7265,8.75,0.0,20HCONIC A	209P	208
RC - PARABOLA,12,0.84,0.07,1,1.5708,0.0,0,0,11.08,8.645,0.0,12H(209P	209
104 FORM 3);	209P	210
212,2,21,1.638,0.07,1,1.5708,0.0,0,0,8.681,8.75,0.0,21HCONIC ARC	211P	211
- HYPERBOLA,12,0.833,0.07,1,1.5708,0.0,0,0,9.0835,8.645,0.0,12H	211P	212
(104 FORM 2);	211P	213

212,2,19,1.449,0.07,1,1.5708,0.0,0,0,6.7755,8.75,0.0,19HCONIC AR	213P	214
C - ELLIPSE,12,0.812,0.07,1,1.5708,0.0,0,0,7.094,8.645,0.0,12H(1	213P	215
04 FORM 1);	213P	216
212,2,19,1.477,0.07,1,1.5708,0.0,0,0,4.7615,8.75,0.0,19HCONIC AR	215P	217
C - GENERAL,12,0.84,0.07,1,1.5708,0.0,0,0,5.08,8.645,0.0,12H(104	215P	218
FORM 0);	215P	219
212,1,21,1.547,0.07,1,1.5708,0.0,0,0,2.7265,8.75,0.0,21HCOMPOSIT	217P	220
E CURVE (102);	217P	221
212,1,18,1.295,0.07,1,1.5708,0.0,0,0,0.8525,8.75,0.0,18HCIRCULAR	219P	222
ARC (100);	219P	223
212,1,6,0.6188,0.125,1,1.5708,0.0,0,0,3.0,5.625,0.0,6HSIMPLE;	221P	224
212,2,23,1.792,0.07,1,1.5708,0.0,0,0,6.604,6.75,0.0,23HRATIONAL	223P	225
B-SPLINE CURVE,12,0.833,0.07,1,1.5708,0.0,0,0,7.0835,6.645,0.0,	223P	226
12H(126 FORM 0);	223P	227
212,2,23,1.792,0.07,1,1.5708,0.0,0,0,8.604,6.75,0.0,23HRATIONAL	225P	228
B-SPLINE CURVE,17,1.176,0.07,1,1.5708,0.0,0,0,8.912,6.645,0.0,	225P	229
17HLINE (126 FORM 1);	225P	230
212,2,23,1.792,0.07,1,1.5708,0.0,0,0,10.604,6.75,0.0,23HRATIONAL	227P	231
B-SPLINE CURVE,25,1.834,0.07,1,1.5708,0.0,0,0,10.583,6.645,0.0,	227P	232
25HCIRCULAR ARC (126 FORM 2);	227P	233
212,2,23,1.792,0.07,1,1.5708,0.0,0,0,12.604,6.75,0.0,23HRATIONAL	229P	234
B-SPLINE CURVE,27,1.974,0.07,1,1.5708,0.0,0,0,12.513,6.645,0.0,	229P	235
27HELLIPTICAL ARC (126 FORM 3);	229P	236
212,2,23,1.792,0.07,1,1.5708,0.0,0,0,14.604,6.75,0.0,23HRATIONAL	231P	237
B-SPLINE CURVE,26,1.911,0.07,1,1.5708,0.0,0,0,14.5445,6.645,	231P	238
0.0,26HPARABOLIC ARC (126 FORM 4);	231P	239
212,2,23,1.792,0.07,1,1.5708,0.0,0,0,0.604002,4.75,0.0,23HRATION	233P	240
AL B-SPLINE CURVE,27,2.002,0.07,1,1.5708,0.0,0,0,0.499002,4.645,	233P	241
0.0,27HHYPERBOLIC ARC (126 FORM 5);	233P	242
212,2,16,1.239,0.07,1,1.5708,0.0,0,0,0.8805,0.75,0.0,16HSINGLE S	235P	243
UBFIGURE,14,1.068,0.07,1,1.5708,0.0,0,0,0.946,0.645,0.0,14HINSTA	235P	244
NCE (408);	235P	245
212,2,21,1.68,0.07,1,1.5708,0.0,0,0,2.66,0.75,0.0,21HRECTANGULAR	237P	246
SUBFIGURE,14,1.026,0.07,1,1.5708,0.0,0,0,2.967,0.645,0.0,14HINS	237P	247
TANCE (412);	237P	248
212,2,18,1.414,0.07,1,1.5708,0.0,0,0,4.793,0.75,0.0,18HCIRCULAR	239P	249
SUBFIGURE,14,1.033,0.07,1,1.5708,0.0,0,0,5.0335,0.645,0.0,14HINS	239P	250
TANCE (414);	239P	251
212,5,17,1.746,0.09,1,1.5708,0.0,0,0,14.627,1.75,0.0,17HCALS TES	241P	252
T NETWORK,11,1.098,0.09,1,1.5708,0.0,0,0,14.951,1.615,0.0,11HMIL	241P	253
-D-28000,7,0.666,0.09,1,1.5708,0.0,0,0,15.167,1.48,0.0,7HCLASS I	241P	254
,17,1.755,0.09,1,1.5708,0.0,0,0,14.6225,1.345,0.0,17HREFERENCE D	241P	255
RAWING,8,0.783,0.09,1,1.5708,0.0,0,0,15.1085,1.21,0.0,8HI-ENTITY	241P	256
;	241P	257
212,3,2,0.2002,0.125,1,1.5708,0.0,0,0,7.0,5.625,0.0,2HIM,3,0.3,	243P	258
0.125,1002,1.5708,0.0,0,0,7.2,5.625,0.0,3Hbed,3,0.2992,0.125,1,	243P	259
1.5708,0.0,0,0,7.5,5.625,0.0,3HDED;	243P	260
212,2,1,0.1133,0.125,1,1.5708,0.0,0,0,11.0,5.625,0.0,1HS,3,	245P	261
0.343,0.125,1,1.5708,0.0,0,0,11.1133,5.53125,0.0,3HSUB;	245P	262
212,2,1,0.1133,0.125,1,1.5708,0.0,0,0,9.0,5.625,0.0,1HS,5,	247P	263
0.5568,0.125,1,1.5708,0.0,0,0,9.1133,5.71875,0.0,5HSUPER;	247P	264
212,2,4,0.4324,0.125,1,1.5708,0.0,0,0,5.0,5.625,0.0,4HDUAL,5,	249P	265
0.5376,0.125,1,1.5708,0.0,0,0,5.0,5.4375,0.0,5HSTACK;	249P	266
212,2,16,1.246,0.07,1,1.5708,0.0,0,0,10.877,4.75,0.0,16HNOTE - S	251P	267
UBSCRIPT,12,0.826,0.07,1,1.5708,0.0,0,0,11.087,4.645,0.0,12H(212	251P	268
FORM 4);	251P	269
212,2,18,1.407,0.07,1,1.5708,0.0,0,0,8.7965,4.75,0.0,18HNOTE - S	253P	270
UPERSCRIP,12,0.826,0.07,1,1.5708,0.0,0,0,9.087,4.645,0.0,12H(21	253P	271
2 FORM 3);	253P	272
212,2,20,1.575,0.07,1,1.5708,0.0,0,0,6.7125,4.75,0.0,20HNOTE - I	255P	273
MBEDDED FONT,19,1.365,0.07,1,1.5708,0.0,0,0,6.8175,4.645,0.0,19H	255P	274
CHANGE (212 FORM 2);	255P	275
212,2,17,1.316,0.07,1,1.5708,0.0,0,0,4.842,4.75,0.0,17HNOTE - DU	257P	276
AL STACK,12,0.798,0.07,1,1.5708,0.0,0,0,5.101,4.645,0.0,12H(212	257P	277
FORM 1);	257P	278
212,2,22,1.722,0.07,1,1.5708,0.0,0,0,14.639,2.75,0.0,22HINTERCHA	259P	279

RACTER SPACING,13,0.924,0.07,1,1.5708,0.0,0,0,15.038,2.645,0.0,	259P	280
13H(406 FORM 18);	259P	281
212,1,7,1.3,0.125,1,1.5708,0.0,0,0,	261P	282
14.8,3.5,0.0,7HSPACING,	261P	283
0,1,289;	261P	284
408,25,1.5,1.5,0.0,1.0;	263P	285
0;	265P	286
0;	267P	287
0;	269P	288
0;	271P	289
0;	273P	290
0;	275P	291
0;	277P	292
102,3,59,57,141;	279P	293
0;	281P	294
0;	283P	295
406,2,17.0,11.0;	285P	296
404,1,55,0.0,0.0,0,0,1,285;	287P	297
406,1,80.0;	289P	298
412,25,1.0,3.0,1.0,0.0,2,2,1.0,0.75,0.0,0;	291P	299
414,25,3,5.5,1.5,0.0,0.5,0.5236,2.0944,0;	293P	300
100,0.0,0.0,0.0,-0.5,0.0,0.5,0.0;	295P	301
S 16G 3D 296P 301	T	1

Attachment I

LGTABLE IGES File Printout

CONFORMANCE:	This IGES file conforms to the Technical Illustration	S	1
	Class I Subset of MIL-D-28000 Amendment 1, 20 Dec. 1988.	S	2
		S	3
ILLUSTRATION		S	4
IDENTIFIER:	LGTABLE, Rev. A - Landing Gear Tabular Illustration for	S	5
	the CALS Test Network Reference Technical Publication.	S	6
	Developed from a McDonnell Aircraft Company illustration.	S	7
		S	8
1H,,1H;,7HLGTABLE,7HLGTABLE,4HNONE,4HTEST,32,38,6,308,15,		G	1
7HLGTABLE,1.0,1,2HIN,25,0.1,		G	2
13H890707.090000,0.0001,20.0,		G	3
7HFARRELL,17HCALS TEST NETWORK,6,0;		G	4
410	1 0 0 0 0 0 0 000020100D		1
410	0 0 1 0 0 0 0 OVIEW 1D		2
406	2 0 0 0 0 0 0 000020001D		3
406	0 0 1 16 0 0 0 2D		4
404	3 0 0 0 0 0 0 000000101D		5
404	0 0 1 0 0 0 0 ODRAWING 3D		6
212	4 0 0 0 0 0 0 000000101D		7
212	0 0 2 0 0 0 0 OTX0044 4D		8
110	6 0 1 0 0 0 0 000000101D		9
110	0 0 2 0 0 0 0 OTX0044 5D		10
110	8 0 1 0 0 0 0 000010101D		11
110	0 0 2 0 0 0 0 OTX0044 6D		12
110	10 0 1 0 0 0 0 000010101D		13
110	0 0 2 0 0 0 0 OTX0044 7D		14
110	12 0 1 0 0 0 0 000010101D		15
110	0 0 2 0 0 0 0 OTX0044 8D		16
212	14 0 0 0 0 0 0 000000101D		17
212	0 0 2 0 0 0 0 OTX0045 9D		18
110	16 0 1 0 0 0 0 000000101D		19
110	0 0 2 0 0 0 0 OTX0045 10D		20
110	18 0 1 0 0 0 0 000010101D		21
110	0 0 2 0 0 0 0 OTX0045 11D		22
110	20 0 1 0 0 0 0 000010101D		23
110	0 0 2 0 0 0 0 OTX0045 12D		24
110	22 0 1 0 0 0 0 000010101D		25
110	0 0 2 0 0 0 0 OTX0045 13D		26
110	24 0 1 0 0 0 0 000000001D		27
110	3 4 2 0 0 0 0 OLN0141 14D		28
110	26 0 1 0 0 0 0 000000001D		29
110	3 4 2 0 0 0 0 OLN0142 15D		30
110	28 0 1 0 0 0 0 000000001D		31
110	2 0 2 0 0 0 0 OLN0143 16D		32
110	30 0 1 0 0 0 0 000000001D		33
110	3 4 2 0 0 0 0 OLN0144 17D		34
110	32 0 1 0 0 0 0 000000001D		35
110	2 0 2 0 0 0 0 OLN0145 18D		36
110	34 0 1 0 0 0 0 000000001D		37
110	3 4 2 0 0 0 0 OLN0146 19D		38
110	36 0 1 0 0 0 0 000000001D		39
110	4 7 2 0 0 0 0 OLN0147 20D		40
112	38 0 1 0 0 0 0 000000001D		41
112	4 7 6 0 0 0 0 OPC0013 21D		42
112	44 0 1 0 0 0 0 000000001D		43
112	4 7 5 0 0 0 0 OPC0014 22D		44
112	49 0 1 0 0 0 0 000000001D		45
112	4 7 6 0 0 0 0 OPC0015 23D		46
112	55 0 1 0 0 0 0 000000001D		47
112	2 0 5 0 0 0 0 OPC0016 24D		48
112	60 0 1 0 0 0 0 000000001D		49
112	3 4 6 0 0 0 0 OPC0017 25D		50
112	66 0 1 0 0 0 0 000000001D		51
112	4 7 6 0 0 0 0 OPC0018 26D		52
112	72 0 1 0 0 0 0 000000001D		53
112	3 4 6 0 0 0 0 OPC0019 27D		54

112	78	0	1	0	0	0	000000001D	55
112	4	7	6	0	0	0PC0020	28D	56
112	84	0	1	0	0	0	000000001D	57
112	3	4	6	0	0	0PC0021	29D	58
112	90	0	1	0	0	0	000000001D	59
112	4	7	6	0	0	0PC0022	30D	60
110	96	0	1	0	0	0	000000001D	61
110	4	7	2	0	0	0LN0148	31D	62
110	98	0	1	0	0	0	000000001D	63
110	4	7	2	0	0	0LN0149	32D	64
0	100	0	0	0	0	0	000000001D	65
0	0	0	2	0	0	0MATRIX	33D	66
100	102	0	1	0	0	0	000000001D	67
100	4	7	2	0	0	0OCR0093	34D	68
110	104	0	1	0	0	0	000000001D	69
110	2	0	2	0	0	0LN0150	35D	70
110	106	0	1	0	0	0	000000001D	71
110	2	0	2	0	0	0LN0151	36D	72
110	108	0	1	0	0	0	000000001D	73
110	4	7	2	0	0	0LN0152	37D	74
110	110	0	1	0	0	0	000000001D	75
110	4	7	2	0	0	0LN0153	38D	76
110	112	0	1	0	0	0	000000001D	77
110	4	7	2	0	0	0LN0154	39D	78
110	114	0	1	0	0	0	000000001D	79
110	4	7	2	0	0	0LN0155	40D	80
110	116	0	1	0	0	0	000000001D	81
110	4	7	2	0	0	0LN0156	41D	82
110	118	0	1	0	0	0	000000001D	83
110	4	7	2	0	0	0LN0157	42D	84
0	120	0	0	0	0	0	000000001D	85
0	0	0	3	0	0	0MATRIX	43D	86
0	123	0	1	0	0	0	000000001D	87
0	2	0	3	0	0	0LC0007	44D	88
124	126	0	0	0	0	0	000000001D	89
124	0	0	3	0	0	0MATRIX	45D	90
104	129	0	1	0	0	89	000000001D	91
104	3	4	3	0	0	0LC0008	46D	92
124	132	0	0	0	0	0	000000001D	93
124	0	0	3	0	0	0MATRIX	47D	94
104	135	0	1	0	0	93	000000001D	95
104	4	7	3	0	0	0LC0009	48D	96
104	138	0	1	0	0	89	000000001D	97
104	2	0	3	0	0	0LC0010	49D	98
112	141	0	1	0	0	0	000000001D	99
112	4	7	5	0	0	0PC0023	50D	100
100	146	0	1	0	0	0	000000001D	101
100	2	0	2	0	0	0OCR0094	51D	102
110	148	0	1	0	0	0	000000001D	103
110	4	7	2	0	0	0LN0158	52D	104
110	150	0	1	0	0	0	000000001D	105
110	2	0	2	0	0	0LN0159	53D	106
110	152	0	1	0	0	0	000000001D	107
110	2	0	2	0	0	0LN0160	54D	108
110	154	0	1	0	0	0	000000001D	109
110	2	0	2	0	0	0LN0161	55D	110
110	156	0	1	0	0	0	000000001D	111
110	2	0	2	0	0	0LN0162	56D	112
110	158	0	1	0	0	0	000000001D	113
110	2	0	2	0	0	0LN0163	57D	114
110	160	0	1	0	0	0	000000001D	115
110	2	0	2	0	0	0LN0164	58D	116
110	162	0	1	0	0	0	000000001D	117
110	3	4	2	0	0	0LN0165	59D	118
110	164	0	1	0	0	0	000000001D	119
110	3	4	2	0	0	0LN0166	60D	120

110	166	0	1	0	0	0	000000001D	121
110	3	4	2	0	0	0LN0167	61D	122
110	168	0	1	0	0	0	000000001D	123
110	3	4	2	0	0	0LN0168	62D	124
100	170	0	1	0	0	0	000000001D	125
100	4	7	2	0	0	0CR0095	63D	126
110	172	0	1	0	0	0	000000001D	127
110	4	7	2	0	0	0LN0169	64D	128
110	174	0	1	0	0	0	000000001D	129
110	4	7	2	0	0	0LN0170	65D	130
100	176	0	1	0	0	0	000000001D	131
100	4	7	2	0	0	0CR0096	66D	132
110	178	0	1	0	0	0	000000001D	133
110	4	7	2	0	0	0LN0171	67D	134
110	180	0	1	0	0	0	000000001D	135
110	2	0	2	0	0	0LN0172	68D	136
110	182	0	1	0	0	0	000000001D	137
110	2	0	2	0	0	0LN0173	69D	138
110	184	0	1	0	0	0	000000001D	139
110	2	0	2	0	0	0LN0174	70D	140
110	186	0	1	0	0	0	000000001D	141
110	2	0	2	0	0	0LN0175	71D	142
110	188	0	1	0	0	0	000000001D	143
110	3	4	2	0	0	0LN0176	72D	144
110	190	0	1	0	0	0	000000001D	145
110	3	4	2	0	0	0LN0177	73D	146
110	192	0	1	0	0	0	000000001D	147
110	2	0	2	0	0	0LN0178	74D	148
100	194	0	1	0	0	0	000000001D	149
100	2	0	2	0	0	0CR0097	75D	150
110	196	0	1	0	0	0	000000001D	151
110	3	4	2	0	0	0LN0179	76D	152
110	198	0	1	0	0	0	000000001D	153
110	3	4	2	0	0	0LN0180	77D	154
124	200	0	0	0	0	0	000000001D	155
124	0	0	3	0	0	OMATRIX	78D	156
104	203	0	1	0	0	155	000000001D	157
104	2	0	4	0	0	0LC0011	79D	158
110	207	0	1	0	0	0	000000001D	159
110	2	0	2	0	0	0LN0181	80D	160
110	209	0	1	0	0	0	000000001D	161
110	2	0	2	0	0	0LN0182	81D	162
110	211	0	1	0	0	0	000000001D	163
110	3	4	2	0	0	0LN0183	82D	164
110	213	0	1	0	0	0	000000001D	165
110	3	4	2	0	0	0LN0184	83D	166
110	215	0	1	0	0	0	000000001D	167
110	3	4	2	0	0	0LN0185	84D	168
110	217	0	1	0	0	0	000000001D	169
110	2	0	2	0	0	0LN0186	85D	170
110	219	0	1	0	0	0	000000001D	171
110	2	0	2	0	0	0LN0187	86D	172
100	221	0	1	0	0	0	000000001D	173
100	2	0	2	0	0	0CR0098	87D	174
100	223	0	1	0	0	0	000000001D	175
100	4	7	2	0	0	0CR0099	88D	176
110	225	0	1	0	0	0	000000001D	177
110	3	4	2	0	0	0LN0188	89D	178
110	227	0	1	0	0	0	000000001D	179
110	3	4	2	0	0	0LN0189	90D	180
110	229	0	1	0	0	0	000000001D	181
110	2	0	2	0	0	0LN0190	91D	182
110	231	0	1	0	0	0	000000001D	183
110	2	0	2	0	0	0LN0191	92D	184
110	233	0	1	0	0	0	000000001D	185
110	2	0	2	0	0	0LN0192	93D	186

110	235	0	1	0	0	0	000000001D	187
110	3	4	2	0	0	0LN0193	94D	188
100	237	0	1	0	0	0	000000001D	189
100	4	7	2	0	0	OCR0100	95D	190
110	239	0	1	0	0	0	000000001D	191
110	2	0	2	0	0	0LN0194	96D	192
112	241	0	1	0	0	0	000000001D	193
112	4	7	6	0	0	OPC0024	97D	194
110	247	0	1	0	0	0	000000001D	195
110	4	7	2	0	0	0LN0195	98D	196
110	249	0	1	0	0	0	000000001D	197
110	4	7	2	0	0	0LN0196	99D	198
100	251	0	1	0	0	0	000000001D	199
100	2	0	2	0	0	OCR0101	100D	200
110	253	0	1	0	0	0	000000001D	201
110	4	7	2	0	0	0LN0197	101D	202
110	255	0	1	0	0	0	000000001D	203
110	4	7	2	0	0	0LN0198	102D	204
104	257	0	1	0	0	155	000000001D	205
104	4	7	3	0	0	0LC0012	103D	206
110	260	0	1	0	0	0	000000001D	207
110	4	7	2	0	0	0LN0199	104D	208
100	262	0	1	0	0	0	000000001D	209
100	4	7	2	0	0	OCR0102	105D	210
0	264	0	1	0	0	0	000000001D	211
0	3	4	2	0	0	0LN0200	106D	212
110	266	0	1	0	0	0	000000001D	213
110	4	7	2	0	0	0LN0201	107D	214
110	268	0	1	0	0	0	000000001D	215
110	4	7	2	0	0	0LN0202	108D	216
110	270	0	1	0	0	0	000000001D	217
110	4	7	2	0	0	0LN0203	109D	218
100	272	0	1	0	0	0	000000001D	219
100	4	7	2	0	0	OCR0103	110D	220
100	274	0	1	0	0	0	000000001D	221
100	2	0	2	0	0	OCR0104	111D	222
110	276	0	1	0	0	0	000000001D	223
110	4	7	2	0	0	0LN0204	112D	224
100	278	0	1	0	0	0	000000001D	225
100	4	7	2	0	0	OCR0105	113D	226
100	280	0	1	0	0	0	000000001D	227
100	2	0	2	0	0	OCR0106	114D	228
100	282	0	1	0	0	0	000000001D	229
100	2	0	2	0	0	OCR0107	115D	230
110	284	0	1	0	0	0	000000001D	231
110	2	0	2	0	0	0LN0205	116D	232
110	286	0	1	0	0	0	000000001D	233
110	2	0	2	0	0	0LN0206	117D	234
110	288	0	1	0	0	0	000000001D	235
110	2	0	2	0	0	0LN0207	118D	236
110	290	0	1	0	0	0	000000001D	237
110	2	0	2	0	0	0LN0208	119D	238
110	292	0	1	0	0	0	000000001D	239
110	2	0	2	0	0	0LN0209	120D	240
110	294	0	1	0	0	0	000000001D	241
110	4	7	1	0	0	0LN0210	121D	242
110	295	0	1	0	0	0	000000001D	243
110	4	7	1	0	0	0LN0211	122D	244
110	296	0	1	0	0	0	000000001D	245
110	2	0	1	0	0	0LN0212	123D	246
110	297	0	1	0	0	0	000000001D	247
110	2	0	1	0	0	0LN0213	124D	248
110	298	0	1	0	0	0	000000001D	249
110	2	0	1	0	0	0LN0214	125D	250
110	299	0	1	0	0	0	000000001D	251
110	2	0	1	0	0	0LN0215	126D	252

110	300	0	1	0	0	0	000000001D	253
110	2	0	1	0	0	0LN0216	127D	254
110	301	0	1	0	0	0	000000001D	255
110	4	7	1	0	0	0LN0217	128D	256
212	302	0	0	0	0	0	000000101D	257
212	0	0	2	0	0	0TX0046	129D	258
212	304	0	0	0	0	0	000000101D	259
212	0	0	3	0	0	0TX0047	130D	260
212	307	0	0	0	0	0	000000101D	261
212	0	0	2	0	0	0TX0048	131D	262
212	309	0	0	0	0	0	000000101D	263
212	0	0	2	0	0	0TX0049	132D	264
212	311	0	0	0	0	0	000000101D	265
212	0	0	2	0	0	0TX0050	133D	266
212	313	0	0	0	0	0	000000101D	267
212	0	0	2	0	0	0TX0051	134D	268
212	315	0	0	0	0	0	000000101D	269
212	0	0	6	0	0	0TX0052	135D	270
110	321	0	1	0	0	0	000000001D	271
110	4	7	1	0	0	0LN0218	136D	272
212	322	0	0	0	0	0	000000101D	273
212	0	0	6	0	0	0TX0053	137D	274
212	328	0	0	0	0	0	000000101D	275
212	0	0	6	0	0	0TX0054	138D	276
212	334	0	0	0	0	0	000000101D	277
212	0	0	6	0	0	0TX0055	139D	278
212	340	0	0	0	0	0	000000101D	279
212	0	0	6	0	0	0TX0056	140D	280
212	346	0	0	0	0	0	000000101D	281
212	0	0	2	0	0	0TX0057	141D	282
110	348	0	1	0	0	0	000000001D	283
110	4	7	2	0	0	0LN0219	142D	284
110	350	0	1	0	0	0	000000001D	285
110	4	7	2	0	0	0LN0220	143D	286
100	352	0	1	0	0	0	000000001D	287
100	4	7	2	0	0	0CRO108	144D	288
110	354	0	1	0	0	0	000000001D	289
110	4	7	2	0	0	0LN0221	145D	290
110	356	0	1	0	0	0	000000001D	291
110	2	0	2	0	0	0LN0222	146D	292
110	358	0	1	0	0	0	000000001D	293
110	2	0	2	0	0	0LN0223	147D	294
110	360	0	1	0	0	0	000000001D	295
110	2	0	2	0	0	0LN0224	148D	296
110	362	0	1	0	0	0	000000001D	297
110	2	0	2	0	0	0LN0225	149D	298
110	364	0	1	0	0	0	000000001D	299
110	2	0	2	0	0	0LN0226	150D	300
110	366	0	1	0	0	0	000000001D	301
110	4	7	2	0	0	0LN0227	151D	302
110	368	0	1	0	0	0	000000001D	303
110	2	0	2	0	0	0LN0228	152D	304
100	370	0	1	0	0	0	000000001D	305
100	4	7	2	0	0	0CRO109	153D	306
110	372	0	1	0	0	0	000000001D	307
110	2	0	2	0	0	0LN0229	154D	308
100	374	0	1	0	0	0	000000001D	309
100	2	0	2	0	0	0CRO110	155D	310
110	376	0	1	0	0	0	000000001D	311
110	2	0	2	0	0	0LN0230	156D	312
110	378	0	1	0	0	0	000000001D	313
110	4	7	2	0	0	0LN0231	157D	314
100	380	0	1	0	0	0	000000001D	315
100	4	7	2	0	0	0CRO111	158D	316
110	382	0	1	0	0	0	000000001D	317
110	2	0	2	0	0	0LN0232	159D	318

100	384	0	1	0	0	0	000000001D	319
100	2	0	2	0	0	OCR0112	160D	320
100	386	0	1	0	0	0	000000001D	321
100	2	0	2	0	0	OCR0113	161D	322
100	388	0	1	0	0	0	000010001D	323
100	2	0	2	0	0	OCR0114	162D	324
100	390	0	1	0	0	0	000010001D	325
100	2	0	2	0	0	OCR0115	163D	326
100	392	0	1	0	0	0	000010001D	327
100	2	0	2	0	0	OCR0116	164D	328
100	394	0	1	0	0	0	000000001D	329
100	2	0	2	0	0	OCR0117	165D	330
100	396	0	1	0	0	0	000000001D	331
100	2	0	2	0	0	OCR0118	166D	332
100	398	0	1	0	0	0	000000001D	333
100	2	0	2	0	0	OCR0119	167D	334
100	400	0	1	0	0	0	000000001D	335
100	2	0	2	0	0	OCR0120	168D	336
100	402	0	1	0	0	0	000000001D	337
100	2	0	2	0	0	OCR0121	169D	338
100	404	0	1	0	0	0	000000001D	339
100	2	0	2	0	0	OCR0122	170D	340
100	406	0	1	0	0	0	000000001D	341
100	2	0	2	0	0	OCR0123	171D	342
100	408	0	1	0	0	0	000000001D	343
100	2	0	2	0	0	OCR0124	172D	344
110	410	0	1	0	0	0	000000001D	345
110	4	7	2	0	0	0LN0233	173D	346
110	412	0	1	0	0	0	000000001D	347
110	4	7	2	0	0	0LN0234	174D	348
100	414	0	1	0	0	0	000000001D	349
100	2	0	2	0	0	OCR0125	175D	350
100	416	0	1	0	0	0	000000001D	351
100	2	0	2	0	0	OCR0126	176D	352
110	418	0	1	0	0	0	000000001D	353
110	4	7	2	0	0	0LN0235	177D	354
100	420	0	1	0	0	0	000000001D	355
100	2	0	2	0	0	OCR0127	178D	356
100	422	0	1	0	0	0	000000001D	357
100	2	0	2	0	0	OCR0128	179D	358
100	424	0	1	0	0	0	000000001D	359
100	2	0	2	0	0	OCR0129	180D	360
100	426	0	1	0	0	0	000000001D	361
100	2	0	2	0	0	OCR0130	181D	362
100	428	0	1	0	0	0	000000001D	363
100	2	0	2	0	0	OCR0131	182D	364
100	430	0	1	0	0	0	000000001D	365
100	2	0	2	0	0	OCR0132	183D	366
100	432	0	1	0	0	0	000000001D	367
100	2	0	2	0	0	OCR0133	184D	368
100	434	0	1	0	0	0	000000001D	369
100	2	0	2	0	0	OCR0134	185D	370
100	436	0	1	0	0	0	000000001D	371
100	2	0	2	0	0	OCR0135	186D	372
100	438	0	1	0	0	0	000000001D	373
100	2	0	2	0	0	OCR0136	187D	374
100	440	0	1	0	0	0	000000001D	375
100	2	0	2	0	0	OCR0137	188D	376
100	442	0	1	0	0	0	000000001D	377
100	2	0	2	0	0	OCR0138	189D	378
100	444	0	1	0	0	0	000000001D	379
100	2	0	2	0	0	OCR0139	190D	380
100	446	0	1	0	0	0	000000001D	381
100	2	0	2	0	0	OCR0140	191D	382
100	448	0	1	0	0	0	000000001D	383
100	2	0	2	0	0	OCR0141	192D	384

100	450	0	1	0	0	0	000000001D	385
100	2	0	2	0	0	0CR0142	193D	386
100	452	0	1	0	0	0	000000001D	387
100	2	0	2	0	0	0CR0143	194D	388
100	454	0	1	0	0	0	000000001D	389
100	2	0	2	0	0	0CR0144	195D	390
100	456	0	1	0	0	0	000000001D	391
100	2	0	2	0	0	0CR0145	196D	392
100	458	0	1	0	0	0	000000001D	393
100	2	0	2	0	0	0CR0146	197D	394
100	460	0	1	0	0	0	000000001D	395
100	2	0	2	0	0	0CR0147	198D	396
110	462	0	1	0	0	0	000000001D	397
110	4	7	2	0	0	0LN0236	199D	398
100	464	0	1	0	0	0	000000001D	399
100	2	0	2	0	0	0CR0148	200D	400
100	466	0	1	0	0	0	000000001D	401
100	4	7	2	0	0	0CR0149	201D	402
212	468	0	0	0	0	0	000000101D	403
212	0	0	2	0	0	0TX0058	202D	404
212	470	0	0	0	0	0	000000101D	405
212	0	0	2	0	0	0TX0059	203D	406
100	472	0	1	0	0	0	000000001D	407
100	2	0	2	0	0	0CR0150	204D	408
100	474	0	1	0	0	0	000000001D	409
100	2	0	2	0	0	0CR0151	205D	410
100	476	0	1	0	0	0	000000001D	411
100	2	0	2	0	0	0CR0152	206D	412
100	478	0	1	0	0	0	000000001D	413
100	2	0	2	0	0	0CR0153	207D	414
100	480	0	1	0	0	0	000000001D	415
100	2	0	2	0	0	0CR0154	208D	416
100	482	0	1	0	0	0	000000001D	417
100	2	0	2	0	0	0CR0155	209D	418
212	484	0	0	0	0	0	000000101D	419
212	0	0	2	0	0	0TX0060	210D	420
100	486	0	1	0	0	0	000000001D	421
100	2	0	2	0	0	0CR0156	211D	422
100	488	0	1	0	0	0	000000001D	423
100	2	0	2	0	0	0CR0157	212D	424
110	490	0	2	0	0	0	000000001D	425
110	2	0	2	0	0	0LN0237	213D	426
100	492	0	1	0	0	0	000000001D	427
100	2	0	2	0	0	0CR0158	214D	428
100	494	0	1	0	0	0	000000001D	429
100	2	0	2	0	0	0CR0159	215D	430
100	496	0	1	0	0	0	000000001D	431
100	2	0	2	0	0	0CR0160	216D	432
100	498	0	1	0	0	0	000000001D	433
100	2	0	2	0	0	0CR0161	217D	434
100	500	0	1	0	0	0	000000001D	435
100	2	0	2	0	0	0CR0162	218D	436
110	502	0	2	0	0	0	000000001D	437
110	2	0	2	0	0	0LN0238	219D	438
110	504	0	2	0	0	0	000000001D	439
110	2	0	2	0	0	0LN0239	220D	440
110	506	0	2	0	0	0	000000001D	441
110	2	0	2	0	0	0LN0240	221D	442
110	508	0	2	0	0	0	000000001D	443
110	2	0	2	0	0	0LN0241	222D	444
110	510	0	2	0	0	0	000000001D	445
110	2	0	2	0	0	0LN0242	223D	446
100	512	0	1	0	0	0	000000001D	447
100	2	0	2	0	0	0CR0163	224D	448
100	514	0	1	0	0	0	000000001D	449
100	2	0	2	0	0	0CR0164	225D	450

100	516	0	1	0	0	0	000000001D	451
100	2	0	2	0	0	OCR0165	226D	452
100	518	0	1	0	0	0	000000001D	453
100	2	0	2	0	0	OCR0166	227D	454
100	520	0	1	0	0	0	000000001D	455
100	2	0	2	0	0	OCR0167	228D	456
100	522	0	1	0	0	0	000000001D	457
100	2	0	2	0	0	OCR0168	229D	458
100	524	0	1	0	0	0	000000001D	459
100	2	0	2	0	0	OCR0169	230D	460
100	526	0	1	0	0	0	000000001D	461
100	2	0	2	0	0	OCR0170	231D	462
100	528	0	1	0	0	0	000000001D	463
100	2	0	2	0	0	OCR0171	232D	464
110	530	0	2	0	0	0	000000001D	465
110	2	0	2	0	0	OLN0243	233D	466
110	532	0	2	0	0	0	000000001D	467
110	2	0	2	0	0	OLN0244	234D	468
100	534	0	1	0	0	0	000000001D	469
100	4	7	2	0	0	OCR0172	235D	470
100	536	0	1	0	0	0	000000001D	471
100	2	0	2	0	0	OCR0173	236D	472
110	538	0	1	0	0	0	000000001D	473
110	4	7	2	0	0	OLN0245	237D	474
110	540	0	1	0	0	0	000000001D	475
110	4	7	2	0	0	OLN0246	238D	476
212	542	0	0	0	0	0	000000101D	477
212	0	0	2	0	0	OTX0061	239D	478
110	544	0	1	0	0	0	000000001D	479
110	4	7	2	0	0	OLN0247	240D	480
212	546	0	0	0	0	0	000000101D	481
212	0	0	2	0	0	OTX0062	241D	482
100	548	0	1	0	0	0	000000001D	483
100	4	7	2	0	0	OCR0174	242D	484
212	550	0	0	0	0	0	000000101D	485
212	0	0	2	0	0	OTX0063	243D	486
212	552	0	0	0	0	0	000000101D	487
212	0	0	2	0	0	OTX0064	244D	488
212	554	0	0	0	0	0	000000101D	489
212	0	0	2	0	0	OTX0065	245D	490
212	556	0	0	0	0	0	000000101D	491
212	0	0	2	0	0	OTX0066	246D	492
212	558	0	0	0	0	0	000000101D	493
212	0	0	2	0	0	OTX0067	247D	494
212	560	0	0	0	0	0	000000101D	495
212	0	0	2	0	0	OTX0068	248D	496
212	562	0	0	0	0	0	000000101D	497
212	0	0	2	0	0	OTX0069	249D	498
212	564	0	0	0	0	0	000000101D	499
212	0	0	2	0	0	OTX0070	250D	500
212	566	0	0	0	0	0	000000101D	501
212	0	0	2	0	0	OTX0071	251D	502
212	568	0	0	0	0	0	000000101D	503
212	0	0	2	0	0	OTX0072	252D	504
212	570	0	0	0	0	0	000000101D	505
212	0	0	2	0	0	OTX0073	253D	506
212	572	0	0	0	0	0	000000101D	507
212	0	0	2	0	0	OTX0074	254D	508
212	574	0	0	0	0	0	000000101D	509
212	0	0	2	0	0	OTX0075	255D	510
212	576	0	0	0	0	0	000000101D	511
212	0	0	2	0	0	OTX0076	256D	512
212	578	0	0	0	0	0	000000101D	513
212	0	0	2	0	0	OTX0077	257D	514
212	580	0	0	0	0	0	000000101D	515
212	0	0	2	0	0	OTX0078	258D	516

100	582	0	1	0	0	0	000000001D	517	
100	2	0	2	0	0	OCR0175	259D	518	
110	584	0	1	0	0	0	000000001D	519	
110	2	0	2	0	0	OLN0248	260D	520	
100	586	0	1	0	0	0	000000001D	521	
100	2	0	2	0	0	OCR0176	261D	522	
212	588	0	0	0	0	0	000000101D	523	
212	0	0	2	0	0	OTX0079	262D	524	
110	590	0	2	0	0	0	000000001D	525	
110	2	0	2	0	0	OLN0249	263D	526	
100	592	0	1	0	0	0	000000001D	527	
100	2	0	2	0	0	OCR0177	264D	528	
212	594	0	0	0	0	0	000000101D	529	
212	0	0	3	0	0	OTX0080	265D	530	
102	597	0	1	0	0	0	000010101D	531	
102	0	0	2	0	0	OCC0001	266D	532	
102	599	0	1	0	0	0	000010101D	533	
102	0	0	2	0	0	OCC0002	267D	534	
230	601	0	1	0	0	0	000000101D	535	
230	0	0	1	0	0	OSA0001	268D	536	
230	602	0	1	0	0	0	000000101D	537	
230	0	0	1	0	0	OSA0002	269D	538	
230	603	0	1	0	0	0	000000101D	539	
230	0	0	1	0	0	OSA0003	270D	540	
230	604	0	1	0	0	0	000000101D	541	
230	0	0	1	0	0	OSA0004	271D	542	
230	605	0	1	0	0	0	000000101D	543	
230	0	0	1	0	0	OSA0005	272D	544	
410,1,1.0,0,0,0,0,0,0,0,0;								1P	1
406,2,8.0,10.0,0,0;								3P	2
404,1,1,0.0,0.0,0,0,1,3;								5P	3
212,1,8,0.447288888889,0.737499967217E-01,1,1.57079648972,0.0,								7P	4
0,0,3.98648322635,6.38281513378,0.0,8H52Z-C007,0,0;								7P	5
110,3.139793396,7.63025188446,0.0,3.9621776708,6.41969013214,								9P	6
0.0,0,0;								9P	7
110,3.139793396,7.63025188446,0.0,3.26575749424,7.49821762393,								11P	8
0.0,0,0;								11P	9
110,3.139793396,7.63025188446,0.0,3.21612670173,7.46450138993,								13P	10
0.0,0,0;								13P	11
110,3.26575749424,7.49821762393,0.0,3.21612670173,								15P	12
7.46450138993,0.0,0,0;								15P	13
212,1,7,0.391377777778,0.737499967217E-01,1,1.57079648972,0.0,								17P	14
0,0,2.91526950412,6.15860820934,0.0,7HDOOR 6L,0,0;								17P	15
110,2.95098209381,7.28634929657,0.0,2.89096394857,								19P	16
6.1954832077,0.0,0,0;								19P	17
110,2.95098209381,7.28634929657,0.0,2.97104836143,								21P	18
7.10497304426,0.0,0,0;								21P	19
110,2.95098209381,7.28634929657,0.0,2.91113896784,								23P	20
7.10826918731,0.0,0,0;								23P	21
110,2.97104836143,7.10497304426,0.0,2.91113896784,								25P	22
7.10826918731,0.0,0,0;								25P	23
110,3.22573868047,8.48009536082,0.0,3.46320986732,								27P	24
8.28457527992,0.0,0,0;								27P	25
110,3.22573868047,8.48009536082,0.0,3.99514697784,								29P	26
8.34000845538,0.0,0,0;								29P	27
110,3.46320986732,8.28457527992,0.0,4.1303702345,								31P	28
8.16310475303,0.0,0,0;								31P	29
110,3.99514697784,8.34000845538,0.0,4.1303702345,								33P	30
8.16310475303,0.0,0,0;								33P	31
110,4.1303702345,8.16310475303,0.0,5.08637892039,								35P	32
8.62007487825,0.0,0,0;								35P	33
110,5.10599845292,7.69963453746,0.0,4.89834165756,								37P	34
7.86455860173,0.0,0,0;								37P	35
110,5.10599845292,7.69963453746,0.0,4.60185826193,								39P	36
7.73279196555,0.0,0,0;								39P	37
112,3,1,2,1,0.0,0.608479141435,2.81060871347,0.514352604635,								41P	38

0.352218720157,-0.120523001026,7.94295330381,0.857109739944,	41P	39
-0.221126112778,-0.700113644031E-02,0.0,0.0,0.0,0.0,	41P	40
3.22683709689,0.492331610595,0.489509022022E-01,	41P	41
-0.271523249759E-01,8.38103818385,0.353059092907,	41P	42
-0.866030556195E-01,-0.157726848992E-02,0.0,0.0,0.0,0.0,0.0;	41P	43
112,3,1,2,1,0.0,0.589326159213,3.22573868047,0.808554380552,	43P	44
0.11684643206,0.0,8.48009536082,0.603137803668,	43P	45
-0.222408241566,0.0,0.0,0.0,0.0,0.0,3.74282231578,	43P	46
0.557665023012,0.405813877033E-01,0.0,8.75829668019,	43P	47
0.200957753436,-0.772435659376E-01,0.0,0.0,0.0,0.0,0.0,0.0;	43P	48
112,3,1,2,1,0.0,0.93414422702,3.7938613754,0.550449517515,	45P	49
0.463479917274,-0.213538068179,8.62262887343,0.906232049983,	45P	50
-0.601583445657,0.272083906776,0.0,0.0,0.0,0.0,4.53843771213,	45P	51
0.800886166798,-0.117757437549,-0.174067267614,9.16601467133,	45P	52
0.462011535103,0.140417114354,0.221791377146,0.0,0.0,0.0,0.0,	45P	53
0,0;	45P	54
112,3,1,2,1,0.0,0.800012319783,3.7938613754,0.964069858511,	47P	55
-0.16754687591,0.0,8.62262887343,0.300537980611,	47P	56
0.293785282217,0.0,0.0,0.0,0.0,0.0,4.4578958361,	47P	57
0.556801157473,-0.107233303234,0.0,9.05109133214,	47P	58
0.616490830366,0.188028371657,0.0,0.0,0.0,0.0,0.0,0.0;	47P	59
112,3,1,2,1,0.0,1.30061378553,3.7938613754,	49P	60
-0.850498133386E-01,2.00551984128,-0.974130470749,	49P	61
8.62262887343,-1.05933637228,1.67999739109,-0.637201343021,	49P	62
0.0,0.0,0.0,0.0,4.93257673142,0.244850206564,-3.03706261462,	49P	63
-2.14319746516,8.68480342986,0.100221413014,-1.36386833257,	49P	64
-1.40191518915,0.0,0.0,0.0,0.0,0.0;	49P	65
112,3,1,2,1,0.0,1.88059644568,1.38868739952,0.424550525053,	51P	66
0.259915847787,-0.511898309345E-01,6.61438144203,	51P	67
0.849039821024,-0.137739589024,0.206399675294E-01,0.0,0.0,0.0,	51P	68
0.0,2.76586169397,1.61547690507,-0.102160864814,	51P	69
-0.340463475423,7.86122334721,1.03425892841,	51P	70
-0.753065890709E-01,0.1372763877,0.0,0.0,0.0,0.0,0.0;	51P	71
112,3,1,2,1,0.0,0.691157365894,2.76586169397,0.877267771864,	53P	72
-0.301264114574E-01,-0.545211229145E-01,7.86122334721,	53P	73
0.561643452045,-0.222073030796E-01,0.219831592736E-01,0.0,0.0,	53P	74
0.0,0.0,3.33979947684,0.523544525518,-0.683942151702E-01,	53P	75
-0.180009578244E-01,8.2460570269,0.388741416743,	53P	76
0.111658033251E-01,0.725806626455E-02,0.0,0.0,0.0,0.0,0.0;	53P	77
112,3,1,2,1,0.0,0.691226278488,5.10599845292,0.933218880369,	55P	78
-0.117617407626E-01,-0.307001470268E-02,7.69963453746,	55P	79
0.364506316709,0.214529813889E-01,0.783057530248E-02,0.0,0.0,	55P	80
0.0,0.0,5.74443026605,0.630784298417,-0.866142883675E-02,	55P	81
-0.101391413290E-02,7.96442713711,0.280215008573,	55P	82
0.180085629750E-01,0.258615405360E-02,0.0,0.0,0.0,0.0,0.0;	55P	83
112,3,1,2,1,0.0,1.21342098273,4.40223178579,0.91922720332,	57P	84
0.152619289395E-02,-0.505298405105E-02,7.64359930503,	57P	85
0.411987534137,-0.595853378827E-02,0.120037666357E-02,0.0,0.0,	57P	86
0.0,0.0,5.51086070369,1.092820449,-0.248362792891E-01,	57P	87
-0.902781039294E-02,8.13688496351,0.488801626771,	57P	88
-0.233940334043E-02,0.214462836402E-02,0.0,0.0,0.0,0.0,0.0;	57P	89
112,3,1,2,1,0.0,0.218674953992,4.20281272236,0.911141248302,	59P	90
0.474668575679E-02,-0.494298761367E-02,7.55387341486,	59P	91
0.411712569435,-0.664207894997E-02,0.117424611376E-02,0.0,0.0,	59P	92
0.0,0.0,4.40223178579,0.199542668671,0.719176084154E-04,	59P	93
-0.516876341020E-04,7.64359930503,0.894328319747E-01,	59P	94
-0.280779387877E-03,0.122788095414E-04,0.0,0.0,0.0,0.0,0.0;	59P	95
110,4.19909847225,7.59042248844,0.0,4.22995513997,	61P	96
7.28678579574,0.0,0.0;	61P	97
110,4.07740280443,7.38127280807,0.0,4.03956734688,	63P	98
7.68538229875,0.0,0.0;	63P	99
0,-0.2262994093,0.974057789533,0.0,0.0,0.974057789533,	65P	100
0.2262994093,0.0,0.0,0.0,0.0,-1.0,0.0,0.0;	65P	101
100,0.0,4.72744,8.00896,4.01308,8.15702,4.04615,	67P	102
7.74805,0.0;	67P	103
110,4.01308185211,8.15702424214,0.0,3.43370182056,	69P	104

7.92044347105,0.0,0,0;	69P	105
110,3.63622402223,7.83893704655,0.0,3.99194882553,	71P	106
7.98313884566,0.0,0,0;	71P	107
110,3.49268150104,7.51439100256,0.0,4.04614978419,	73P	108
7.74804845382,0.0,0,0;	73P	109
110,4.01701787124,7.49055304444,0.0,3.97758522049,	75P	110
7.32258374085,0.0,0,0;	75P	111
110,4.00230125803,7.65284063066,0.0,4.01701787124,	77P	112
7.49055304444,0.0,0,0;	77P	113
110,3.96922609409,7.33717659979,0.0,3.86616805498,	79P	114
7.43766069352,0.0,0,0;	79P	115
110,4.06232446142,7.28713266959,0.0,4.05562020653,	81P	116
7.25719928805,0.0,0,0;	81P	117
110,3.94921410324,7.24056458266,0.0,3.90581867241,	83P	118
7.09135472175,0.0,0,0;	83P	119
0,	85P	120
0,	85P	121
0;	85P	122
0,	87P	123
0,	87P	124
0;	87P	125
124,0.822707872394,0.568464384725,0.0,3.95000949597,	89P	126
-0.568464384725,0.822707872394,0.0,7.07740599738,0.0,0.0,	89P	127
1.0,0.0,0,0;	89P	128
104,2.45896973343,0.0,0.541030266574,0.0,0.0,	91P	129
-0.420764657064E-02,0.0,0.244755907566E-01,	91P	130
-0.710943841851E-01,-0.488729111792E-02,0.875702038635E-01,0,0;	91P	131
124,0.822707872394,0.568464384725,0.0,4.03714209389,	93P	132
-0.568464384725,0.822707872394,0.0,7.03493684255,0.0,0.0,	93P	133
1.0,0.0,0,0;	93P	134
104,2.45896973343,0.0,0.541030266574,0.0,0.0,	95P	135
-0.168305862825E-01,0.0,0.589429375971E-02,-0.175927530198,	95P	136
-0.977458223580E-02,0.175140407727,0,0;	95P	137
104,2.45896973343,0.0,0.541030266574,0.0,0.0,	97P	138
-0.168305862826E-01,0.0,0.489511815131E-01,-0.14218876837,	97P	139
-0.977458223584E-02,0.175140407727,0,0;	97P	140
112,3,1,2,1,0.0,2.05459638264,3.35844725991,-0.882935710955,	99P	141
-0.368798468698E-01,0.0,7.16184893794,-0.424181962002,	99P	142
0.767654844687E-01,0.0,0.0,0.0,0.0,0.0,1.38868739952,	99P	143
-2.12544320296,-0.155683342562,0.0,6.61438144203,	99P	144
-0.223412267112,0.324055228799,0.0,0.0,0.0,0.0,0.0,0,0;	99P	145
100,0.0,3.28526,7.46766,2.67602,7.60821,2.72503,	101P	146
7.19005,0,0;	101P	147
110,3.28991368897,7.43079825623,0.0,2.72502804771,	103P	148
7.19005116966,0.0,0,0;	103P	149
110,2.68947372936,7.59685723891,0.0,2.86959723605,	105P	150
7.46076209321,0.0,0,0;	105P	151
110,2.67601689973,7.60820534781,0.0,3.26049186278,	107P	152
7.84802615234,0.0,0,0;	107P	153
110,2.86951436863,7.46037242197,0.0,2.82500314829,	109P	154
7.25106527966,0.0,0,0;	109P	155
110,2.87034744677,7.46019525972,0.0,3.23463230518,	111P	156
7.60433804626,0.0,0,0;	111P	157
110,2.98904985523,7.67129767228,0.0,3.14293088214,	113P	158
7.73443788188,0.0,0,0;	113P	159
110,3.00127578718,7.64475569194,0.0,3.15515681409,	115P	160
7.70789590155,0.0,0,0;	115P	161
110,3.21514800111,7.66175689384,0.0,3.06444058941,	117P	162
7.59874875295,0.0,0,0;	117P	163
110,3.00127578718,7.64475569194,0.0,3.06444058941,	119P	164
7.59874875295,0.0,0,0;	119P	165
110,2.99092211927,7.69893344452,0.0,2.98904985523,	121P	166
7.67129767228,0.0,0,0;	121P	167
110,3.13908420749,7.75972706862,0.0,2.99092211927,	123P	168
7.69893344452,0.0,0,0;	123P	169
100,0.0,4.04568296668,7.15966626021,4.22995513997,	125P	170

7.28678579574,4.07740280443,7.38127280807,0,0;	125P	171
110,3.96587729329,7.25325155362,0.0,3.96946468192,	127P	172
7.27170894248,0.0,0,0;	127P	173
110,3.97997722899,7.66837958167,0.0,3.22581091565,	129P	174
7.33611397712,0.0,0,0;	129P	175
100,0.0,3.97022,7.38623,4.19910,7.59042,4.03724,.	131P	176
7.68554,0,0;	131P	177
110,3.87129598587,7.44432656031,0.0,3.76453118153,	133P	178
7.55908587333,0.0,0,0;	133P	179
110,3.49579919375,7.80996154339,0.0,3.43391875704,	135P	180
7.78487678624,0.0,0,0;	135P	181
110,3.61173116388,7.85695741917,0.0,3.68781308514,	137P	182
7.88779909741,0.0,0,0;	137P	183
110,3.56391021322,7.77480031082,0.0,3.63419635854,	139P	184
7.80181971906,0.0,0,0;	139P	185
110,3.5429504875,7.80785282197,0.0,3.61323663282,	141P	186
7.83487223022,0.0,0,0;	141P	187
110,3.61323663282,7.83487223022,0.0,3.63419635854,	143P	188
7.80181971906,0.0,0,0;	143P	189
110,3.58846120814,7.85853390854,0.0,3.61323663282,	145P	190
7.83487223022,0.0,0,0;	145P	191
110,3.44655848055,7.9032114258,0.0,3.64863928831,	147P	192
7.98769935274,0.0,0,0;	147P	193
100,0.0,3.79164605621,7.98614574695,3.64863928831,	149P	194
7.98769935274,3.68781308514,7.88779909741,0,0;	149P	195
110,3.51737299954,7.8322805079,0.0,3.58846120814,	151P	196
7.85853390854,0.0,0,0;	151P	197
110,3.50974491599,7.80075221456,0.0,3.51660449459,	153P	198
7.83301446573,0.0,0,0;	153P	199
124,-0.822707872405,0.568464384709,0.0,3.95000949597,	155P	200
0.568464384709,0.822707872405,0.0,7.07740599738,0.0,0.0,-1.0,	155P	201
0.0,0,0;	155P	202
104,2.45896973342,0.0,0.541030266577,0.0,0.0,	157P	203
-0.420764657030E-02,0.0,-0.488729111784E-02,	157P	204
-0.875702038597E-01,0.389627241056E-01,-0.296209303115E-01,0,	157P	205
0;	157P	206
110,3.56074136658,7.75989646145,0.0,3.56391021322,	159P	207
7.77480031082,0.0,0,0;	159P	208
110,3.5429504875,7.80785282197,0.0,3.56391021322,	161P	209
7.77480031082,0.0,0,0;	161P	210
110,3.56074136658,7.75989646145,0.0,3.50974491599,	163P	211
7.80075221456,0.0,0,0;	163P	212
110,3.6310275119,7.78691586969,0.0,3.63419635854,	165P	213
7.80181971906,0.0,0,0;	165P	214
110,3.56074136658,7.75989646145,0.0,3.6310275119,	167P	215
7.78691586969,0.0,0,0;	167P	216
110,3.51660449459,7.83301446573,0.0,3.5429504875,	169P	217
7.80785282197,0.0,0,0;	169P	218
110,3.43848054238,7.7494813944,0.0,3.50351606543,	171P	219
7.77779989847,0.0,0,0;	171P	220
100,0.0,4.13267516977,7.81466063885,3.43370182056,	173P	221
7.92044347105,3.49268150104,7.51439100256,0,0;	173P	222
100,0.0,4.06672543897,7.69522832406,3.26049186278,	175P	223
7.84802615234,3.28991368897,7.43079825623,0,0;	175P	224
110,3.21789628276,7.70232322644,0.0,3.21514800111,	177P	225
7.66175689384,0.0,0,0;	177P	226
110,3.13908420749,7.75972706862,0.0,3.21789628276,	179P	227
7.70232322644,0.0,0,0;	179P	228
110,3.13908420749,7.75972706862,0.0,3.14293088214,	181P	229
7.73443788188,0.0,0,0;	181P	230
110,3.14293088214,7.73443788188,0.0,3.15515681409,	183P	231
7.70789590155,0.0,0,0;	183P	232
110,3.15515681409,7.70789590155,0.0,3.21530576581,	185P	233
7.66408559811,0.0,0,0;	185P	234
110,2.98904985523,7.67129767228,0.0,3.00127578718,	187P	235
7.64475569194,0.0,0,0;	187P	236

100,0.0,3.44870295285,7.49013625251,3.22594826788,	189P	237
7.33617449086,3.35462033211,7.23622222335,0,0;	189P	238
110,3.35462033211,7.23622222335,0.0,3.80689330111,	191P	239
7.42531294398,0.0,0,0;	191P	240
112,3,1,2,1,0.0,0.566967445147,3.35844725991,0.896023700235,	193P	241
0.189061626394E-01,-0.505639148805E-02,7.16184893794,	193P	242
0.430469723276,-0.100897997044E-01,0.120118614437E-02,0.0,0.0,	193P	243
0.0,0.0,3.87161941156,0.517406493338,0.331279984627E-02,	193P	244
-0.921541843963E-03,7.40288678964,0.238232303792,	193P	245
-0.258662828585E-02,0.218919618278E-03,0.0,0.0,0.0,0.0,0,0;	193P	246
110,3.72106974823,7.53865353232,0.0,3.83915311129,	195P	247
7.41845353075,0.0,0,0;	195P	248
110,3.85125966664,7.42464415858,0.0,3.94934753956,	197P	249
7.31982290233,0.0,0,0;	197P	250
100,0.0,3.86003,7.42542,3.87130,7.44433,3.83915,	199P	251
7.41845,0,0;	199P	252
110,3.95698275944,7.28491912962,0.0,3.9660157186,	201P	253
7.31469474646,0.0,0,0;	201P	254
110,3.94305108978,7.08883230568,0.0,4.0000202755,	203P	255
7.24875144207,0.0,0,0;	203P	256
104,2.45896973343,0.0,0.541030266572,0.0,0.0,	205P	257
-0.168305862822E-01,0.0,-0.977458223411E-02,-0.175140407723,	205P	258
0.744538135736E-01,0.769019752249E-01,0,0;	205P	259
110,3.94562263552,6.88529094846,0.0,3.85849003761,	207P	260
6.9277601033,0.0,0,0;	207P	261
100,0.0,3.92411966591,7.0854407431,3.90581867241,	209P	262
7.09135472175,3.94305108978,7.08883230568,0,0;	209P	263
0,	211P	264
0;	211P	265
110,4.03398901889,7.25798734429,0.0,4.0254312987,	213P	266
7.23519035191,0.0,0,0;	213P	267
110,4.0451687493,7.22549365752,0.0,4.13230134722,	215P	268
7.18302450269,0.0,0,0;	215P	269
110,4.0000202755,7.24875144207,0.0,4.02518272537,	217P	270
7.23272876551,0.0,0,0;	217P	271
100,0.0,3.98286,7.19347,4.00002,7.24875,3.94921,	219P	272
7.24056,0,0;	219P	273
100,0.0,3.99344,7.22586,4.03399,7.25799,3.96946,	221P	274
7.27171,0,0;	221P	275
110,4.07677224176,7.37196531398,0.0,4.05098529205,	223P	276
7.29763238281,0.0,0,0;	223P	277
100,0.0,3.99163,7.22216,4.06232,7.28713,3.96602,	225P	278
7.31469,0,0;	225P	279
100,0.0,3.98493,7.19223,4.05562,7.25720,3.95931,	227P	280
7.28476,0,0;	227P	281
100,0.0,3.96037,7.32726,3.96923,7.33718,3.94935,	229P	282
7.31982,0,0;	229P	283
110,4.01902893587,7.48574291856,0.0,4.0609114388,	231P	284
7.48290546921,0.0,0,0;	231P	285
110,3.8841884276,7.46215355187,0.0,3.98787037609,	233P	286
7.50889366307,0.0,0,0;	233P	287
110,3.98325607226,7.54426773316,0.0,3.88608011562,	235P	288
7.49007603416,0.0,0,0;	235P	289
110,3.98384175892,7.65643306664,0.0,3.8730658563,	237P	290
7.50498181613,0.0,0,0;	237P	291
110,3.99962157337,7.61328683199,0.0,3.88221575107,	239P	292
7.50202499018,0.0,0,0;	239P	293
110,6.4,2.73753929138,0.0,0.6,2.73753929138,0.0,0,0,0;	241P	294
110,6.4,1.63753986359,0.0,6.4,2.73753929138,0.0,0,0,0;	243P	295
110,0.6,2.46003929138,0.0,6.4,2.46003929138,0.0,0,0,0;	245P	296
110,5.4,1.63753986359,0.0,5.4,2.46003929138,0.0,0,0,0;	247P	297
110,0.6,2.21953929138,0.0,6.4,2.21953929138,0.0,0,0,0;	249P	298
110,2.1,1.63753986359,0.0,2.1,2.46003929138,0.0,0,0,0;	251P	299
110,1.6,1.63753986359,0.0,1.6,2.46003929138,0.0,0,0,0;	253P	300
110,0.6,2.73753929138,0.0,0.6,1.63753986359,0.0,0,0,0;	255P	301
212,1,3,0.167733333333,0.737499967217E-01,1,1.57079648972,0.0,	257P	302

0,0,5.80224479251,2.30822540447,0.0,3HBUS,0,0;	257P	303
212,1,37,3.13194430967,0.972222205665E-01,1,1.57079648972,0.0,	259P	304
0,0,1.93479881667,2.5579686703,0.0,37HESSENTIAL CIRCUIT BREAKER	259P	305
PANEL NO. 1,0,0;	259P	306
212,1,12,0.670833333333,0.737499967217E-01,1,1.57079648972,	261P	307
0.0,0,0,3.44232238346,2.30822254345,0.0,12HNOMENCLATURE,0,0;	261P	308
212,1,7,0.391377777778,0.737499967217E-01,1,1.57079648972,0.0,	263P	309
0,0,0.910783360534,2.30822635815,0.0,7HREF DES,0,0;	263P	310
212,1,4,0.223644444444,0.737499967217E-01,1,1.57079648972,0.0,	265P	311
0,0,1.72757781559,2.30822540447,0.0,4HZONE,0,0;	265P	312
212,1,8,0.753955526416,0.972222205665E-01,1,1.57079648972,0.0,	267P	313
0,0,0.695005950663,2.55797248499,0.0,8H52Z-C007,0,0;	267P	314
212,3,13,0.726744444444,0.737499967217E-01,1,1.57079648972,	269P	315
0.0,0,0,2.23292983585,2.05118633434,0.0,13HR MLG WOW PWR,13,	269P	316
0.726744444444,0.737499967217E-01,1,1.57079648972,0.0,0,0,	269P	317
2.23292983585,1.91229744545,0.0,13HL MLG WOW PWR,14,	269P	318
0.782755555556,0.737499967217E-01,1,1.57079648972,0.0,0,0,	269P	319
2.23292983585,1.77340855656,0.0,14HLDG GR POS IND,0,0;	269P	320
110,0.6,1.63753986359,0.0,6.4,1.63753986359,0.0,0,0;	271P	321
212,3,2,0.111822222222,0.737499967217E-01,1,1.57079648972,	273P	322
0.0,0,0,1.77439464145,2.05118633434,0.0,2HL1,2,	273P	323
0.111822222222,0.737499967217E-01,1,1.57079648972,0.0,0,0,	273P	324
1.77439464145,1.91229744545,0.0,2HM1,2,0.111822222222,	273P	325
0.737499967217E-01,1,1.57079648972,0.0,0,0,1.77439464145,	273P	326
1.77340855656,0.0,2HN1,0,0;	273P	327
212,3,8,0.447288888889,0.737499967217E-01,1,1.57079648972,0.0,	275P	328
0,0,0.851796756321,2.05118633434,0.0,8H41CBC033,8,	275P	329
0.447288888889,0.737499967217E-01,1,1.57079648972,0.0,0,0,	275P	330
0.851796756321,1.91229744545,0.0,8H41CBC034,8,0.447288888889,	275P	331
0.737499967217E-01,1,1.57079648972,0.0,0,0,0.851796756321,	275P	332
1.77340855656,0.0,8H42CBC005,0,0;	275P	333
212,3,5,0.279655555556,0.737499967217E-01,1,1.57079648972,0.0,	277P	334
0,0,4.99522365146,2.05118633434,0.0,5H28VDC,5,0.279655555556,	277P	335
0.737499967217E-01,1,1.57079648972,0.0,0,0,4.99522365146,	277P	336
1.91229744545,0.0,5H28VDC,5,0.279655555556,0.737499967217E-01,	277P	337
1,1.57079648972,0.0,0,0,4.99522365146,1.77340855656,0.0,5H28VDC,	277P	338
0,0;	277P	339
212,3,9,0.5031,0.737499967217E-01,1,1.57079648972,0.0,0,0,	279P	340
5.64113391452,2.05118633434,0.0,9HESS 28VDC,9,0.5031,	279P	341
0.737499967217E-01,1,1.57079648972,0.0,0,0,5.64113391452,	279P	342
1.91229744545,0.0,9HESS 28VDC,9,0.5031,0.737499967217E-01,1,	279P	343
1.57079648972,0.0,0,0,5.64113391452,1.77340855656,0.0,9HESS 28VD	279P	344
C,0,0;	279P	345
212,1,10,0.559011111111,0.737499967217E-01,1,1.57079648972,	281P	346
0.0,0,0,5.62985862308,2.56970764324,0.0,10H(24-50-12),0,0;	281P	347
110,4.70588709214,5.27583267886,0.0,4.87115087145,	283P	348
5.59221722308,0.0,0,0;	283P	349
110,4.87796913147,5.65999675751,0.0,4.87796913147,	285P	350
5.61999675751,0.0,0,0;	285P	351
100,0.0,4.81797,5.62000,4.87115,5.59222,4.87797,	287P	352
5.62000,0,0;	287P	353
110,4.87796913147,5.65999675751,0.0,2.30484413147,	289P	354
5.65999675751,0.0,0,0;	289P	355
110,4.80796913147,5.25999675751,0.0,4.80796913147,	291P	356
5.04999675751,0.0,0,0;	291P	357
110,4.72796913147,5.30999675751,0.0,4.80796913147,	293P	358
5.30999675751,0.0,0,0;	293P	359
110,4.72796913147,5.25999675751,0.0,4.80796913147,	295P	360
5.25999675751,0.0,0,0;	295P	361
110,4.72796913147,5.3181070113,0.0,4.72796913147,	297P	362
5.01499675751,0.0,0,0;	297P	363
110,4.80796913147,5.04999675751,0.0,4.72796913147,	299P	364
5.04999675751,0.0,0,0;	299P	365
110,4.69796913147,5.24229165919,0.0,4.69796913147,	301P	366
4.07333267886,0.0,0,0;	301P	367
110,4.69796913147,4.94333267886,0.0,2.31796913147,	303P	368

4.94333267886,0.0,0,0;	303P	369
100,0.0,4.77297,5.24239,4.70589,5.27583,4.69797,	305P	370
5.24229,0,0;	305P	371
110,4.70296913147,4.98999675751,0.0,4.69796913147,	307P	372
4.98999675751,0.0,0,0;	307P	373
100,0.0,4.70297,5.01500,4.70297,4.99000,4.72797,	309P	374
5.01500,0,0;	309P	375
110,2.31796913147,5.25583267886,0.0,4.69920165363,	311P	376
5.25583267886,0.0,0,0;	311P	377
110,2.25796913147,5.23583267886,0.0,2.25796913147,	313P	378
4.96333267886,0.0,0,0;	313P	379
100,0.0,2.29797,5.25583,2.29797,5.23583,2.29797,	315P	380
5.27583,0,0;	315P	381
110,4.80796913147,5.30999675751,0.0,4.80796913147,	317P	382
5.47126073709,0.0,0,0;	317P	383
100,0.0,4.40119134108,5.41365748358,4.44919134108,	319P	384
5.41365748358,4.44919134108,5.41365748358,0,0;	319P	385
100,0.0,4.26096118325,5.41365748358,4.30896118325,	321P	386
5.41365748358,4.30896118325,5.41365748358,0,0;	321P	387
100,0.0,4.12073102542,5.41365748358,4.16873102542,	323P	388
5.41365748358,4.16873102542,5.41365748358,0,0;	323P	389
100,0.0,3.98050086759,5.41365748358,4.02850086759,	325P	390
5.41365748358,4.02850086759,5.41365748358,0,0;	325P	391
100,0.0,3.84027070976,5.41365748358,3.88827070976,	327P	392
5.41365748358,3.88827070976,5.41365748358,0,0;	327P	393
100,0.0,3.70004055193,5.41365748358,3.74804055193,	329P	394
5.41365748358,3.74804055193,5.41365748358,0,0;	329P	395
100,0.0,3.5598103941,5.41365748358,3.6078103941,5.41365748358,	331P	396
3.6078103941,5.41365748358,0,0;	331P	397
100,0.0,3.41958023627,5.41365748358,3.46758023627,	333P	398
5.41365748358,3.46758023627,5.41365748358,0,0;	333P	399
100,0.0,3.27935007845,5.41365748358,3.32735007845,	335P	400
5.41365748358,3.32735007845,5.41365748358,0,0;	335P	401
100,0.0,3.13911992062,5.41365748358,3.18711992062,	337P	402
5.41365748358,3.18711992062,5.41365748358,0,0;	337P	403
100,0.0,2.99888976279,5.41365748358,3.04688976279,	339P	404
5.41365748358,3.04688976279,5.41365748358,0,0;	339P	405
100,0.0,2.85865960496,5.41365748358,2.90665960496,	341P	406
5.41365748358,2.90665960496,5.41365748358,0,0;	341P	407
100,0.0,2.5781992893,5.41365748358,2.6261992893,5.41365748358,	343P	408
2.6261992893,5.41365748358,0,0;	343P	409
110,2.29796913147,5.27583267886,0.0,2.25796913147,	345P	410
5.27583267886,0.0,0,0;	345P	411
110,2.29796913147,5.23583267886,0.0,2.25796913147,	347P	412
5.23583267886,0.0,0,0;	347P	413
100,0.0,2.43796913147,5.41365748358,2.48596913147,	349P	414
5.41365748358,2.48596913147,5.41365748358,0,0;	349P	415
100,0.0,2.71842944713,5.41365748358,2.76642944713,	351P	416
5.41365748358,2.76642944713,5.41365748358,0,0;	351P	417
110,4.69796913147,4.07333267886,0.0,2.30484413147,	353P	418
4.07333267886,0.0,0,0;	353P	419
100,0.0,4.33107626217,4.22333267886,4.37907626217,	355P	420
4.22333267886,4.37907626217,4.22333267886,0,0;	355P	421
100,0.0,4.19084610434,4.22333267886,4.23884610434,	357P	422
4.22333267886,4.23884610434,4.22333267886,0,0;	357P	423
100,0.0,3.91038578868,4.22333267886,3.95838578868,	359P	424
4.22333267886,3.95838578868,4.22333267886,0,0;	359P	425
100,0.0,3.77015563085,4.22333267886,3.81815563085,	361P	426
4.22333267886,3.81815563085,4.22333267886,0,0;	361P	427
100,0.0,4.05061594651,4.22333267886,4.09861594651,	363P	428
4.22333267886,4.09861594651,4.22333267886,0,0;	363P	429
100,0.0,3.62992547302,4.22333267886,3.67792547302,	365P	430
4.22333267886,3.67792547302,4.22333267886,0,0;	365P	431
100,0.0,4.05061594651,4.45833267886,4.09861594651,	367P	432
4.45833267886,4.09861594651,4.45833267886,0,0;	367P	433
100,0.0,4.19084610434,4.45833267886,4.23884610434,	369P	434

4.45833267886,4.23884610434,4.45833267886,0,0;	369P	435
100,0.0,4.47107626217,4.57583267886,4.51907626217,	371P	436
4.57583267886,4.51907626217,4.57583267886,0,0;	371P	437
100,0.0,4.33107626217,4.69333267886,4.37907626217,	373P	438
4.69333267886,4.37907626217,4.69333267886,0,0;	373P	439
100,0.0,4.19084610434,4.69333267886,4.23884610434,	375P	440
4.69333267886,4.23884610434,4.69333267886,0,0;	375P	441
100,0.0,4.05061594651,4.69333267886,4.09861594651,	377P	442
4.69333267886,4.09861594651,4.69333267886,0,0;	377P	443
100,0.0,3.77015563085,4.45833267886,3.81815563085,	379P	444
4.45833267886,3.81815563085,4.45833267886,0,0;	379P	445
100,0.0,4.33107626217,4.45833267886,4.37907626217,	381P	446
4.45833267886,4.37907626217,4.45833267886,0,0;	381P	447
100,0.0,3.91038578868,4.45833267886,3.95838578868,	383P	448
4.45833267886,3.95838578868,4.45833267886,0,0;	383P	449
100,0.0,3.20923499953,4.22333267886,3.25723499953,	385P	450
4.22333267886,3.25723499953,4.22333267886,0,0;	385P	451
100,0.0,3.0690048417,4.22333267886,3.1170048417,4.22333267886,	387P	452
3.1170048417,4.22333267886,0,0;	387P	453
100,0.0,2.92877468387,4.22333267886,2.97677468387,	389P	454
4.22333267886,2.97677468387,4.22333267886,0,0;	389P	455
100,0.0,2.78854452604,4.22333267886,2.83654452604,	391P	456
4.22333267886,2.83654452604,4.22333267886,0,0;	391P	457
100,0.0,2.64831436821,4.22333267886,2.69631436821,	393P	458
4.22333267886,2.69631436821,4.22333267886,0,0;	393P	459
100,0.0,2.50808421038,4.22333267886,2.55608421038,	395P	460
4.22333267886,2.55608421038,4.22333267886,0,0;	395P	461
110,2.25796913147,4.92333267886,0.0,2.25796913147,	397P	462
4.12020767886,0.0,0,0;	397P	463
100,0.0,2.36785405256,4.22333267886,2.41585405256,	399P	464
4.22333267886,2.41585405256,4.22333267886,0,0;	399P	465
100,0.0,2.25797,4.07333,2.30484,4.07333,2.25797,	401P	466
4.12021,0,0;	401P	467
212,1,1,0.719000000000E-01,0.901388848821E-01,1,1.57079648972,	403P	468
0.0,0,0,2.10804458618,4.17826200897,0.0,1H5,0,0;	403P	469
212,1,1,0.719000000000E-01,0.901388848821E-01,1,1.57079648972,	405P	470
0.0,0,0,2.10804458618,4.41326166565,0.0,1H4,0,0;	405P	471
100,0.0,2.36785405256,4.45833267886,2.41585405256,	407P	472
4.45833267886,2.41585405256,4.45833267886,0,0;	407P	473
100,0.0,2.64831436821,4.45833267886,2.69631436821,	409P	474
4.45833267886,2.69631436821,4.45833267886,0,0;	409P	475
100,0.0,2.78854452604,4.45833267886,2.83654452604,	411P	476
4.45833267886,2.83654452604,4.45833267886,0,0;	411P	477
100,0.0,2.92877468387,4.45833267886,2.97677468387,	413P	478
4.45833267886,2.97677468387,4.45833267886,0,0;	413P	479
100,0.0,2.50808421038,4.45833267886,2.55608421038,	415P	480
4.45833267886,2.55608421038,4.45833267886,0,0;	415P	481
100,0.0,2.36785405256,4.69333267886,2.41585405256,	417P	482
4.69333267886,2.41585405256,4.69333267886,0,0;	417P	483
212,1,1,0.719000000000E-01,0.901388848821E-01,1,1.57079648972,	419P	484
0.0,0,0,2.10804553986,4.648262276,0.0,1H3,0,0;	419P	485
100,0.0,2.50808421038,4.69333267886,2.55608421038,	421P	486
4.69333267886,2.55608421038,4.69333267886,0,0;	421P	487
100,0.0,2.64831436821,4.69333267886,2.69631436821,	423P	488
4.69333267886,2.69631436821,4.69333267886,0,0;	423P	489
110,2.7102657769,5.05228199717,0.0,2.65647803844,	425P	490
4.74063336055,0.0,0,0;	425P	491
100,0.0,2.92877468387,4.69333267886,2.97677468387,	427P	492
4.69333267886,2.97677468387,4.69333267886,0,0;	427P	493
100,0.0,3.34946515736,4.69333267886,3.39746515736,	429P	494
4.69333267886,3.39746515736,4.69333267886,0,0;	429P	495
100,0.0,3.20923499953,4.69333267886,3.25723499953,	431P	496
4.69333267886,3.25723499953,4.69333267886,0,0;	431P	497
100,0.0,3.0690048417,4.69333267886,3.1170048417,4.69333267886,	433P	498
3.1170048417,4.69333267886,0,0;	433P	499
100,0.0,2.78854452604,4.69333267886,2.83654452604,	435P	500

4.69333267886,2.83654452604,4.69333267886,0,0;	435P	501
110,2.85049593473,5.05228199717,0.0,2.79670819627,	437P	502
4.74063336055,0.0,0,0;	437P	503
110,2.99072609256,5.05228199717,0.0,2.9369383541,	439P	504
4.74063336055,0.0,0,0;	439P	505
110,3.13095625039,5.05228199717,0.0,3.07716851193,	441P	506
4.74063336055,0.0,0,0;	441P	507
110,3.27118640822,5.05228199717,0.0,3.21739866976,	443P	508
4.74063336055,0.0,0,0;	443P	509
110,3.41141656605,5.05228199717,0.0,3.35762882759,	445P	510
4.74063336055,0.0,0,0;	445P	511
100,0.0,3.70004055193,5.09958267886,3.74804055193,	447P	512
5.09958267886,3.74804055193,5.09958267886,0,0;	447P	513
100,0.0,3.5598103941,5.09958267886,3.6078103941,5.09958267886,	449P	514
3.6078103941,5.09958267886,0,0;	449P	515
100,0.0,3.41958023627,5.09958267886,3.46758023627,	451P	516
5.09958267886,3.46758023627,5.09958267886,0,0;	451P	517
100,0.0,3.27935007845,5.09958267886,3.32735007845,	453P	518
5.09958267886,3.32735007845,5.09958267886,0,0;	453P	519
100,0.0,3.13911992062,5.09958267886,3.18711992062,	455P	520
5.09958267886,3.18711992062,5.09958267886,0,0;	455P	521
100,0.0,2.99888976279,5.09958267886,3.04688976279,	457P	522
5.09958267886,3.04688976279,5.09958267886,0,0;	457P	523
100,0.0,2.85865960496,5.09958267886,2.90665960496,	459P	524
5.09958267886,2.90665960496,5.09958267886,0,0;	459P	525
100,0.0,2.71842944713,5.09958267886,2.76642944713,	461P	526
5.09958267886,2.76642944713,5.09958267886,0,0;	461P	527
100,0.0,2.5781992893,5.09958267886,2.6261992893,5.09958267886,	463P	528
2.6261992893,5.09958267886,0,0;	463P	529
110,2.57003561907,5.05228199717,0.0,2.51624788061,	465P	530
4.74063336055,0.0,0,0;	465P	531
110,2.42980546124,5.05228199717,0.0,2.37601772278,	467P	532
4.74063336055,0.0,0,0;	467P	533
100,0.0,2.29797,4.94333,2.29797,4.92333,2.29797,	469P	534
4.96333,0,0;	469P	535
100,0.0,2.43796913147,5.09958267886,2.48596913147,	471P	536
5.09958267886,2.48596913147,5.09958267886,0,0;	471P	537
110,2.29796913147,4.96333267886,0.0,2.25796913147,	473P	538
4.96333267886,0.0,0,0;	473P	539
110,2.29796913147,4.92333267886,0.0,2.25796913147,	475P	540
4.92333267886,0.0,0,0;	475P	541
212,1,1,0.719000000000E-01,0.901388848821E-01,1,1.57079648972,	477P	542
0.0,0,0,2.10804553986,5.054512276,0.0,1H2,0,0;	477P	543
110,2.25796913147,5.27583267886,0.0,2.25796913147,	479P	544
5.61312175751,0.0,0,0;	479P	545
212,1,1,0.719000000000E-01,0.901388848821E-01,1,1.57079648972,	481P	546
0.0,0,0,2.10804553986,5.36858774597,0.0,1H1,0,0;	481P	547
100,0.0,2.25796913147,5.65999675751,2.25796913147,	483P	548
5.61312175751,2.30484413147,5.65999675751,0,0;	483P	549
212,1,1,0.719000000000E-01,0.901388848821E-01,1,1.57079648972,	485P	550
0.0,0,0,2.40055274963,5.71786238129,0.0,1HA,0,0;	485P	551
212,1,1,0.719000000000E-01,0.901388848821E-01,1,1.57079648972,	487P	552
0.0,0,0,2.54078197479,5.71786238129,0.0,1HB,0,0;	487P	553
212,1,1,0.719000000000E-01,0.901388848821E-01,1,1.57079648972,	489P	554
0.0,0,0,2.68101215363,5.71786238129,0.0,1HC,0,0;	489P	555
212,1,1,0.719000000000E-01,0.901388848821E-01,1,1.57079648972,	491P	556
0.0,0,0,2.82124233246,5.71786238129,0.0,1HD,0,0;	491P	557
212,1,1,0.719000000000E-01,0.901388848821E-01,1,1.57079648972,	493P	558
0.0,0,0,2.96147251129,5.71786238129,0.0,1HE,0,0;	493P	559
212,1,1,0.719000000000E-01,0.901388848821E-01,1,1.57079648972,	495P	560
0.0,0,0,3.10170269012,5.71786238129,0.0,1HF,0,0;	495P	561
212,1,1,0.719000000000E-01,0.901388848821E-01,1,1.57079648972,	497P	562
0.0,0,0,3.24193286896,5.71786238129,0.0,1HG,0,0;	497P	563
212,1,1,0.719000000000E-01,0.901388848821E-01,1,1.57079648972,	499P	564
0.0,0,0,4.50377368927,5.71786238129,0.0,1HR,0,0;	499P	565
212,1,1,0.719000000000E-01,0.901388848821E-01,1,1.57079648972,	501P	566

0.0,0,0,4.36377429962,5.71786238129,0.0,1HQ,0,0;
 212,1,1,0.719000000000E-01,0.901388848821E-01,1,1.57079648972,
 0.0,0,0,4.22354412079,5.71786238129,0.0,1HP,0,0;
 212,1,1,0.719000000000E-01,0.901388848821E-01,1,1.57079648972,
 0.0,0,0,4.08331394196,5.71786238129,0.0,1HN,0,0;
 212,1,1,0.719000000000E-01,0.901388848821E-01,1,1.57079648972,
 0.0,0,0,3.94308376312,5.71786238129,0.0,1HM,0,0;
 212,1,1,0.719000000000E-01,0.901388848821E-01,1,1.57079648972,
 0.0,0,0,3.80285358429,5.71786238129,0.0,1HL,0,0;
 212,1,1,0.719000000000E-01,0.901388848821E-01,1,1.57079648972,
 0.0,0,0,3.66262340546,5.71786238129,0.0,1HK,0,0;
 212,1,1,0.719000000000E-01,0.901388848821E-01,1,1.57079648972,
 0.0,0,0,3.52239322662,5.71786238129,0.0,1HJ,0,0;
 212,1,1,0.719000000000E-01,0.901388848821E-01,1,1.57079648972,
 0.0,0,0,3.38216304779,5.71786238129,0.0,1HH,0,0;
 100,0.0,3.91038578868,4.69333267886,3.95838578868,
 4.69333267886,3.95838578868,4.69333267886,0,0;
 110,4.36784302635,4.4891904988,0.0,4.43430949798,
 4.54497485892,0.0,0,0;
 100,0.0,4.47130641999,4.22333267886,4.51930641999,
 4.22333267886,4.51930641999,4.22333267886,0,0;
 212,1,8,0.759000026226,0.901388848821E-01,1,1.57079648972,0.0,
 0,0,3.13067740507,3.78854490692,0.0,8H52Z-C007,0,0;
 110,3.55164672388,5.05228199717,0.0,3.49785898542,
 4.74063336055,0.0,0,0;
 100,0.0,3.48969531519,4.69333267886,3.53769531519,
 4.69333267886,3.53769531519,4.69333267886,0,0;
 212,1,48,2.853333333333,0.737566644812E-01,1,1.57079648972,
 0.0,0,0,3.4963709259,0.179828651249,0.0,48HCALS Test Network LGT
 ABLE Reference Illustration,0,0;
 102,3,21,23,
 25,0,0;
 102,3,11,13,
 15,0,0;
 230,327,1,3.84,5.41,0.0,0.005,0.7854,0,0,0;
 230,325,1,3.98,5.41,0.0,0.005,0.7854,0,0,0;
 230,323,1,4.12,5.41,0.0,0.005,0.7854,0,0,0;
 230,531,1,2.91,7.11,0.0,0.005,0.7854,0,0,0;
 230,533,1,3.22,7.46,0.0,0.005,0.7854,0,0,0;
 S 8G 4D 544P 605

501P 567
 503P 568
 503P 569
 505P 570
 505P 571
 507P 572
 507P 573
 509P 574
 509P 575
 511P 576
 511P 577
 513P 578
 513P 579
 515P 580
 515P 581
 517P 582
 517P 583
 519P 584
 519P 585
 521P 586
 521P 587
 523P 588
 523P 589
 525P 590
 525P 591
 527P 592
 527P 593
 529P 594
 529P 595
 529P 596
 531P 597
 531P 598
 533P 599
 533P 600
 535P 601
 537P 602
 539P 603
 541P 604
 543P 605
 T 1

Attachment J

IDENTITY Entity Listing and Count...

** Entity Occurrence Counts **

Entity	Form	Level	Count	Type
-----	-----	-----	-----	-----
0	0	0	37	Null entity
100	0	0	3	Circular arc
102	0	0	2	Composite curve
104	0	0	1	Conic arc - general form
104	1	0	1	Conic arc - ellipse
104	2	0	1	Conic arc - hyperbola
104	3	0	1	Conic arc - parabola
106	11	0	1	Copious data - Piecewise planar, linear string
106	63	0	1	Simple closed area
110	0	0	27	Line
112	0	0	2	Parametric spline curve
124	0	0	5	Transformation matrix
126	0	0	1	Rational B-spline curve
126	1	0	1	Rational B-spline curve - Line
126	2	0	1	Rational B-spline curve - Circular arc
126	3	0	1	Rational B-spline curve - Elliptical arc
126	4	0	1	Rational B-spline curve - Parabolic arc
126	5	0	1	Rational B-spline curve - Hyperbolic arc
212	0	0	39	General note
212	1	0	1	General note - dual stack dimension
212	2	0	1	General note - imbedded font change dimension
212	3	0	1	General note - superscripted dimension
212	4	0	1	General note - subscripted dimension
212	5	0	1	General note - super-/sub-scripted dimension
212	6	0	1	General note - multiple stack/left justified
212	7	0	1	General note - multiple stack/center justified
212	8	0	1	General note - multiple stack/right justified
212	100	0	1	General note - simple fractional dimension
212	101	0	1	General note - dual stack fractional dimension
212	102	0	1	General note - imbedded font change/double frac
212	105	0	1	General note - super-/sub-scripted fractional
230	0	0	1	Sectioned area
308	0	0	1	Subfigure definition
404	0	0	1	Drawing
406	16	0	1	Property - Drawing size
406	18	0	1	Intercharacter Spacing
408	0	0	1	Single subfigure instance
410	0	0	1	View - Orthographic parallel
412	0	0	1	Rectangular subfigure instance
414	0	0	1	Circular subfigure instance

Attachment K

LGTABLE Entity Listing and Count

** Entity Occurrence Counts **

Entity	Form	Level	Count	Type
-----	----	-----	-----	-----
0	0	0	4	Null entity
100	0	0	85	Circular arc
102	0	0	2	Composite curve
104	0	0	5	Conic arc - general form
110	0	0	116	Line
112	0	0	12	Parametric spline curve
124	0	0	3	Transformation matrix
212	0	0	37	General note
230	0	0	5	Sectioned area
404	0	0	1	Drawing
406	16	0	1	Property - Drawing size
410	0	0	1	View - Orthographic parallel