



CALS TEST NETWORK

AFCTN Test Report 93-060

AFCTB-ID
93-007



Technical Publication Transfer

Using:



Gateway Conversions' Data



MIL-M-28001A (SGML)
MIL-R-28002A (Raster)



Quick Short Test Report

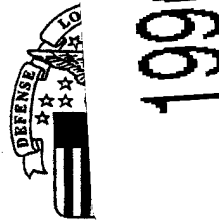

19960822 131

03 February 1993

DISTRIBUTION STATEMENT A
Approved for public release
Distribution Unlimited



Prepared for

Electronic Systems Center

DTIC QUALITY INSPECTED 3

AFCTN Test Report
93-060

AFCTB-ID
93-007

Technical Publication Transfer

Using:

Gateway Conversions' Data

MIL-M-28001A (SGML)

MIL-R-28002A (Raster)

Quick Short Test Report

3 February 1993

Prepared By

Air Force CALS Test Bed
Wright-Patterson AFB, OH 45433

AFCTB Contact

Gary Lammers
(513) 427-2295

AFCTN Contact

Mel Lammers
(513) 427-2295

DTIC QUALITY INSPECTED 3

DISCLAIMER

This document was prepared as an account of work sponsored by the Air Force. Neither the United States Government, the Air Force, nor any of their employees, makes any warranty, express or implied, or assumes any legal liability or responsibility for the accuracy, completeness, or usefulness of any information, apparatus, product, or process disclosed, nor represents that its use would not infringe on privately owned rights. Reference herein to any specific commercial products, process, or service by trade name, trademark, manufacturer, or otherwise, does not necessarily constitute or imply its endorsement, recommendation, or favoring by the United States Government or the Air Force. The views and opinions of authors expressed herein do not necessarily state or reflect those of the United States Government or the Air Force, and shall not be used for advertising or product endorsement purposes.

Available to the public from the
National Technical Information Service
U.S. Department of Commerce
5285 Port Royal Road
Springfield, VA 22161

This report and those involved in its preparation do not endorse any product, process, or company stated herein. Use of these means by anyone does not imply certification by the Air Force CALS Test Network (AFCTN).

Contents

1.	Introduction.....	1
1.1.	Background.....	1
1.2.	Purpose.....	2
2.	Test Parameters.....	3
3.	1840A Analysis.....	5
3.1.	External Packaging.....	5
3.2.	Transmission Envelope.....	5
3.2.1.	Tape Formats.....	5
3.2.2.	Declaration and Header Fields.....	5
4.	IGES Analysis.....	6
5.	SGML Analysis.....	6
6.	Raster Analysis.....	6
7.	CGM Analysis.....	7
8.	Conclusions and Recommendations.....	8
9.	Appendix A - Tapetool Report Logs.....	9
9.1.	Tape Catalog.....	9
9.2.	Tape Evaluation Log.....	10
9.3.	Tape File Set Validation Log - V1.2.8.....	15
9.3.1.	Tape Evaluation Log VTI1.0.1.....	17
9.4.	Other Tape Reading Logs.....	20

10. Appendix B - Detailed Raster Analysis.....21

 10.1. File D001R010.....21

 10.1.1. Output Preview.....21

 10.1.2. Output HiJaak for Windows.....22

 10.1.3. Output IGESView.....23

 10.1.4. Output HiJaak/Ventura Publisher.....24

1. Introduction

1.1 Background

The Department of Defense (DoD) Air Force Continuous Acquisition and Life-Cycle Support (CALs) Test Network (AFCTN) is conducting tests of the military standard for the Automated Interchange of Technical Information, MIL-STD-1840A, and its companion suite of military specifications. The AFCTN is a DoD sponsored confederation of voluntary participants from industry and government managed by the Electronic Systems Center (ESC).

The primary objective of the AFCTN is to evaluate the effectiveness of the CALs standards for technical data interchange and to demonstrate the technical capabilities and operational suitability of those standards. Two general categories of tests are performed to evaluate the standards; formal and informal.

Formal tests are large and comprehensive, which follow a written test plan, require specific authorization from the DoD, and may take months to prepare, execute, and report.

Informal tests are quick and short, used by the AFCTN technical staff, to broaden the testing base. They include representative samples of the many systems and applications used by AFCTN participants. They also allow the AFCTN staff to gain feedback from many industry and government interpretations of the standards, to increase the base of participation in the CALs initiative, and respond to the many requests for help that come from participants. Participants take part voluntarily, benefit by receiving an evaluation of their latest implementation (interpretation) of the standards, interact with the AFCTN technical staff, gain experience using the standards, and develop increased confidence in them. The results of informal tests are reported in Quick Short Test Reports (QSTRs) that briefly summarize the standard(s) tested, the hardware and software used, the nature of the test, and the results.

1.2 Purpose

The purpose of the informal test, reported in this QSTR, was to analyze Gateway Conversions' interpretation and use of the CALS standards in transferring technical publication data. Gateway Conversions used its CALS Technical Data Interchange System to produce data, in accordance with the standards, and delivered it to the AFCTN technical staff on a 9-track magnetic tape.

2. Test Parameters

Test Plan: AFCTB 93-007

Date of
Evaluation: 3 February 1993

Evaluators: George Elwood
Air Force CALS Test Bed
DET 2 HQ ESC/ENCP
4027 Colonel Glenn Hwy
Suite 300
Dayton, OH 45431-1672

Data
Originator: Joe Vide
Gateway Conversion Technology
4709 Creekstone Drive, Ste. 300
Morrisville, NC 27560

Data
Description: Technical Manual Test
1 Document Declaration file
11 Raster files

Data
Source System:

Raster

HARDWARE

Unknown

SOFTWARE

Unknown

Evaluation Tools Used:

MIL-STD-1840A (TAPE)

SUN 3/280

AFCTN Tapetool v1.2.8 UNIX

XSoft CAPS/CALS v40.4

MIL-R-28002 (Raster)

SUN SparcStation 2

ArborText g42tiff

AFCTN validg4

AFCTN calstb.475

IGES Data Analysis (IDA) IGESView v3.0

Island Graphics IslandPaint v3.0

Cheetah

Inset Systems HiJaak v2.1

Inset Systems HiJaak Window v1.0

Software Publishing Corporation

(SPC) Harvard Graphics v3.0

Corel Ventura Publisher

Standards

Tested:

MIL-STD-1840A

MIL-R-28002A

3. 1840A Analysis

3.1 External Packaging

The tape arrived at the Air Force CALS Test Bed (AFCTB) enclosed in a box in accordance with ASTM D 3951. The exterior of the box was marked with the magnetic tape warning label, as required by MIL-STD-1840A, para. 5.3.1.3.

The tape was enclosed in barrier sheet material as required by MIL-STD-1840A, para. 5.3.1.2. Inspection of the tape reel showed the label indicating the recording density, as required by MIL-STD-1840A, para. 5.3.1. Enclosed in the box was a packing list showing all files recorded on the tape.

3.2 Transmission Envelope

The 9-track tape received by the AFCTB contained MIL-STD-1840A files. The files were named per the standard conventions.

3.2.1 Tape Formats

The tape was run through the AFCTN *Tapetool* v1.2.8 utility. No errors were encountered while evaluating the contents of the tape labels.

The tape was also run through TI's *Tapetool* v1.0.1 without a reported error.

The tape was also read using XSoft's *CAPS read1840A* utility without a reported error.

3.2.2 Declaration and Header Fields

The AFCTN version of *Tapetool* did not report any errors during the parsing of the Document Declaration file and data file header records.

When the tape was read using TI's version of *Tapetool*, a more current release, 14 errors and 14 notes were reported. The errors were all the same and relate to the value inserted in the *dstdsys* and *dstdocid* records. MIL-STD-1840A required that an actual value be placed in this record instead of NONE. All files reported this error.

dstdsys: NONE

*** ERROR (MIL-STD-1840A; 5.1.1.2) - Invalid value for '*dstdsys*': .

*** NOTE (MIL-STD-1840A; 5.1.1.2) - The value for Destination System cannot be 'NONE'.

dstdocid: NONE

*** ERROR (MIL-STD-1840A; 5.1.1.2) - Invalid value for '*dstdocid*': .

*** NOTE (MIL-STD-1840A; 5.1.1.2) - The value must be the Destination Organization's Document Number.

The physical structure of the tape did not meet the MIL-STD-1840A requirements.

4. IGES Analysis

No Initial Graphics Exchange Specification (IGES) files were included on this tape.

5. SGML Analysis

The text file on this tape consisted of calls to the graphics entities. The document was small enough that visual inspection was made and the file was determined to be acceptable for the test. No parsing was completed.

6. Raster Analysis

The tape contained 11 Raster files. All 11 files were checked using the AFCTN *validg4* utility. This program reported that all files meet the CALS MIL-R-28002A specification.

A selection of the files were read using the AFCTN *calstb.475* utility. All of the selected files displayed

without a problem. The images were clean with few orphan pixels. The images were straight.

The AFCTB has several tools for viewing Raster files. These tools are not used to generate a pass/fail but to report how commercially available software can handle the files. Many of these products are used in the development of technical publications and are a good indicator of usability. The use of these products is not an endorsement.

The files were converted using ArborText's *g42tiff* utility. File D001R010 reported an error in scan line 1166. It was able to generate a partial file which was less than half the size of the other ten files. When this file was read into Island Graphics' *IslandPaint*, less than half the images was displayed. All of the other files converted and displayed without a problem.

A selection of files were read into IDA's *IGESView* without reported a problem. File D001R010 read in, displayed and printed as a complete page.

A selection of files were converted using Rosetta Technologies' *Prepare* and viewed using *Preview*. No problems were encountered during this procedure. File D001R010 was handled without a problem.

The files were converted to an IMG format using Inset Systems' *HiJaak*. The resulting files were imported into Corel's *Ventura Publisher* and printed. The entire set of files are included in the Appendix to the report.

A selection of files were imported directly into Inset Systems' *HiJaak* for Windows. No problems were noted during this procedure. File D001R010 was handled without a problem.

The Raster files meet the CALS MIL-R-28002A specification.

7. CGM Analysis

No Computer Graphics Metafile (CGM) files were included on this tape.

8. Conclusions and Recommendations

In summary, the tape from Gateway Conversion Technology had several reported errors. All of the errors were the same and relate to invalid values in data headers. The physical structure of the tape does not meet the CALS MIL-STD-1840A requirements.

The Raster images are valid files and meet the CALS MIL-R-28002A specification.

The tape does not meet the CALS MIL-STD-1840A requirements.

GATEWAY CONVERSION TECHNOLOGIES' COMMENTS DATED 16 MAR 93:

The tape that was sent was built with the currently available AFCTN Tapetool, and all tests used to determine if the tape met standards were successfully passed. However, when the tape was read with the TI version of Tapetool, errors were reported in each of the file headers where DSTSYS and DSTDOCID were left blank. The current standard requires that a value now be placed there, instead of NONE.

Otherwise, the tape met standards for external packaging, transmission envelope, tape formats, and Raster file analysis.

We have made modifications to our procedures so that subsequent tapes will include values for DSTSYS and DSTDOCID other than NONE.

9. Appendix A - Tapetool Report Logs

9.1 Tape Catalog

Air Force CALS Test Network Catalog Evaluation - Version 1.2; Release Number 8

Standards referenced:

MIL-STD-1840A (1987) - Automated Interchange of Technical Information

ANSI X3.27 (1987) - File Structure and labeling of Magnetic Tapes
for Information Interchange

ANSI X3.4 (1986) - Coded Character Sets - 7 Bit ASCII

Wed Feb 3 12:17:37 1993

MIL-STD-1840A File Catalog

File Set Directory: /cals/tapetool8/Set102

Page: 1

File Name	File Type	Record Format/ Length	Block Length/Total	Selected/ Extracted
D001	Document Declaration	D/00260	02048/000001	Extracted
D001R001	Raster	F/00128	02048/000015	Extracted
D001R002	Raster	F/00128	02048/000007	Extracted
D001R003	Raster	F/00128	02048/000007	Extracted
D001R004	Raster	F/00128	02048/000003	Extracted
D001R005	Raster	F/00128	02048/000015	Extracted
D001R006	Raster	F/00128	02048/000010	Extracted
D001R007	Raster	F/00128	02048/000011	Extracted
D001R008	Raster	F/00128	02048/000010	Extracted
D001R009	Raster	F/00128	02048/000008	Extracted
D001R010	Raster	F/00128	02048/000030	Extracted
D001R011	Raster	F/00128	02048/000013	Extracted
D001T012	Text	D/00260	02048/000001	Extracted

Catalog Process terminated normally.

9.2 Tape Evaluation Log

Air Force CALS Test Network Tape Evaluation - Version 1.2; Release
Number 8

Standards referenced:

ANSI X3.27 (1987) - File Structure and labeling of Magnetic Tapes
for Information Interchange

ANSI X3.4 (1986) - Coded Character Sets - 7 Bit ASCII

Wed Feb 3 12:17:27 1993

ANSI Tape Import Log

Allocating tape drive /dev/rmt0...

/dev/rmt0 allocated.

VOL1CAL501

4

Label Identifier: VOL1
Volume Identifier: CAL501
Volume Accessibility:
Owner Identifier:
Label Standard Version: 4

HDR1D001 CAL50100010001000000 93033 00000 000000

Label Identifier: HDR1
File Identifier: D001
File Set Identifier: CAL501
File Section Number: 0001
File Sequence Number: 0001
Generation Number: 0000
Generation Version Number: 00
Creation Date: 93033
Expiration Date: 00000
File Accessibility:
Block Count: 000000
Implementation Identifier:

HDR2D0204800260

00

Label Identifier: HDR2
Recording Format: D
Block Length: 02048
Record Length: 00260
Offset Length: 00

***** Tape Mark *****

Actual Block Size Found = 2048 Bytes.

Number of data blocks read = 1.

***** Tape Mark *****

EOF1D001 CALS0100010001000000 93033 00000 000001

Label Identifier: EOF1
File Identifier: D001
File Set Identifier: CALS01
File Section Number: 0001
File Sequence Number: 0001
Generation Number: 0000
Generation Version Number: 00
Creation Date: 93033
Expiration Date: 00000
File Accessibility:
Block Count: 000001
Implementation Identifier:

EOF2D0204800260

00

Label Identifier: EOF2
Recording Format: D
Block Length: 02048
Record Length: 00260
Offset Length: 00

***** Tape Mark *****

HDR1D001R001 CALS0100010002000000 93033 00000 000000

Label Identifier: HDR1
File Identifier: D001R001
File Set Identifier: CALS01
File Section Number: 0001
File Sequence Number: 0002
Generation Number: 0000
Generation Version Number: 00
Creation Date: 93033
Expiration Date: 00000
File Accessibility:
Block Count: 000000
Implementation Identifier:

HDR2F0204800128

00

Label Identifier: HDR2
Recording Format: F
Block Length: 02048
Record Length: 00128
Offset Length: 00

***** Tape Mark *****

Actual Block Size Found = 2048 Bytes.

Number of data blocks read = 15.

***** Tape Mark *****

EOF1D001R001

CALS0100010002000000 93033 00000 000015

Label Identifier: EOF1
File Identifier: D001R001
File Set Identifier: CALS01
File Section Number: 0001
File Sequence Number: 0002
Generation Number: 0000
Generation Version Number: 00
Creation Date: 93033
Expiration Date: 00000
File Accessibility:
Block Count: 000015
Implementation Identifier:

EOF2F0204800128

00

Label Identifier: EOF2
Recording Format: F
Block Length: 02048
Record Length: 00128
Offset Length: 00

***** Tape Mark *****

<<<<< PART OF LOG FILE REMOVED HERE >>>>>

***** Tape Mark *****

HDR1D001T012

CALS0100010013000000 93033 00000 000000

Label Identifier: HDR1
File Identifier: D001T012
File Set Identifier: CALS01
File Section Number: 0001
File Sequence Number: 0013
Generation Number: 0000
Generation Version Number: 00
Creation Date: 93033
Expiration Date: 00000
File Accessibility:
Block Count: 000000
Implementation Identifier:

HDR2D0204800260

00

Label Identifier: HDR2
Recording Format: D
Block Length: 02048
Record Length: 00260
Offset Length: 00

***** Tape Mark *****

Actual Block Size Found = 2048 Bytes.

Number of data blocks read = 1.

***** Tape Mark *****

EOF1D001T012

CALS0100010013000000 93033 00000 000001

Label Identifier: EOF1
File Identifier: D001T012
File Set Identifier: CALS01
File Section Number: 0001
File Sequence Number: 0013
Generation Number: 0000
Generation Version Number: 00
Creation Date: 93033
Expiration Date: 00000
File Accessibility:
Block Count: 000001
Implementation Identifier:

EOF2D0204800260

00

Label Identifier: EOF2
Recording Format: D

Block Length: 02048
Record Length: 00260
Offset Length: 00

***** Tape Mark *****

***** Tape Mark *****

End of Volume CALS01

End Of Tape File Set

Deallocating /dev/rmt0...

Tape Import Process terminated normally.

9.3 Tape File Set Validation Log - V1.2.8

Air Force CALS Test Network File Set Evaluation - Version 1.2; Release Number 8
Standards referenced:

MIL-STD-1840A (1987) - Automated Interchange of Technical Information
MIL-R-28002 (1989) - Raster Graphics Representation In Binary
Format, Requirements For

Wed Feb 3 12:17:37 1993

MIL-STD-1840A File Set Evaluation Log

File Set: Set102

Found file: D001

Extracting Document Declaration Header Records...

Evaluating Document Declaration Header Records...

srcsys: MARTIN MARIETTA CORPORATION

srcdocid: 33D5-49-46-1

srcrelid: NONE

chglvl: 0,0,19930202 PRELIMINARY

dteisu: 19930202

dstsys: NONE

dstdocid: NONE

dstrelid: NONE

dtetrn: 19930202

dlvacc: F33657-84-C-004

filcnt: R11,T1

ttlcls: UNCLASSIFIED

doccls: UNCLASSIFIED

doctyp: PAGE TURNER

docttl: LAMINAR FLOW WORKSTATION

Found file: D001R001

Extracting Raster Header Records...

Evaluating Raster Header Records...

srcdocid: 33D5-49-46-1

dstdocid: NONE

txtfilid: W

figid: cover

srcgph: cover

doccls: UNCLASSIFIED

rtype: 1

rorient: 000,270

rpelcnt: 002560,003297
rdensty: 0300
notes: NONE

Saving Raster Header File: D001R001_HDR
Saving Raster Data File: D001R001_GR4

Found file: D001R002
Extracting Raster Header Records...
Evaluating Raster Header Records...

srcdocid: 33D5-49-46-1
dstdocid: NONE
txtfilid: W
figid: content
srcgph: content
doccls: UNCLASSIFIED
rtype: 1
rorient: 000,270
rpelcnt: 002560,003297
rdensty: 0300
notes: NONE

Saving Raster Header File: D001R002_HDR
Saving Raster Data File: D001R002_GR4

<<<< PART OF LOG FILE REMOVED HERE >>>>

Found file: D001R011
Extracting Raster Header Records...
Evaluating Raster Header Records...

srcdocid: 33D5-49-46-1
dstdocid: NONE
txtfilid: W
figid: 4-1
srcgph: 4-1
doccls: UNCLASSIFIED
rtype: 1
rorient: 000,270
rpelcnt: 002560,003297
rdensty: 0300
notes: NONE

Saving Raster Header File: D001R011_HDR
Saving Raster Data File: D001R011_GR4

Found file: D001T012

Extracting Text Header Records...
Evaluating Text Header Records...

srcdocid: 33D5-49-46-1
dstdocid: NONE
txtfilid: W
doccls: UNCLASSIFIED
notes: NONE

Saving Text Header File: D001T012_HDR
Saving Text Data File: D001T012_TXT

Evaluating numbering scheme...
No errors were encountered during numbering scheme evaluation.
Numbering scheme evaluation complete.

Checking file count...
No errors were encountered during file count verification.
File Count verification complete.

No errors were encountered in Document D001.

No errors were encountered in this File Set.

MIL-STD-1840A File Set Evaluation Complete.

9.3.1 Tape Evaluation Log VTI1.0.1

Texas Instruments File Set Evaluation - Version 1.0; Release Number 1

Standards referenced:

- MIL-STD-1840A (1987) - Automated Interchange of Technical Information
- MIL-STD-804C (1990) - Formats and Coding of Aperture, Camera, Copy,
and Tabulating Cards
- MIL-R-28002 (1989) - Raster Graphics Representation In Binary
Format, Requirements For

Wed Feb 3 12:22:30 1993

MIL-STD-1840A File Set Evaluation Log

File Set: Set003

Found file: D001
Extracting Document Declaration Header Records...
Evaluating Document Declaration Header Records...

srcsys: MARTIN MARIETTA CORPORATION

srcdocid: 33D5-49-46-1

srcrelid: NONE

chglvl: 0,0,19930202 PRELIMINARY

dteisu: 19930202

dstsys: NONE

*** ERROR (MIL-STD-1840A; 5.1.1.2) - Invalid value for 'dstsys: '.

*** NOTE (MIL-STD-1840A; 5.1.1.2) - The value for Destination System cannot be 'NONE'.

dstdocid: NONE

*** ERROR (MIL-STD-1840A; 5.1.1.2) - Invalid value for 'dstdocid: '.

*** NOTE (MIL-STD-1840A; 5.1.1.2) - The value must be the Destination Organization's Document Number.

dstrelid: NONE

dtetrm: 19930202

dlvacc: F33657-84-C-004

filcnt: R11,T1

ttlcls: UNCLASSIFIED

doccls: UNCLASSIFIED

doctyp: PAGE TURNER

docttl: LAMINAR FLOW WORKSTATION

2 error(s), 0 warning(s), and 2 note(s) were encountered in Document Declaration File .D001.

Searching for data files...

Found file: D001R001

Extracting Raster Header Records...

Evaluating Raster Header Records...

srcdocid: 33D5-49-46-1

dstdocid: NONE

*** ERROR (MIL-STD-1840A; 5.1.4.4) - Invalid value for 'dstdocid: '.

*** NOTE (MIL-STD-1840A; 5.1.4.4) - The value must be the Destination Organization's Document Number.

txtfilid: W

figid: cover

srcgph: cover

doccls: UNCLASSIFIED

rtype: 1

rorient: 000,270

rpelcnt: 002560,003297

rdensty: 0300

notes: NONE

1 error(s), 0 warning(s), and 1 note(s) were encountered in Raster File D001R001.

Saving Raster Header File: D001R001_HDR
Saving Raster Data File: D001R001_GR4

<<<<< PART OF LOG FILE REMOVED HERE >>>>>

Found file: D001R011
Extracting Raster Header Records...
Evaluating Raster Header Records...

srcdocid: 33D5-49-46-1
dstdocid: NONE
*** ERROR (MIL-STD-1840A; 5.1.4.4) - Invalid value for 'dstdocid: '
*** NOTE (MIL-STD-1840A; 5.1.4.4) - The value must be the
Destination Organization's Document Number.
txtfilid: W
figid: 4-1
srcgph: 4-1
doccls: UNCLASSIFIED
rtype: 1
rorient: 000,270
rpelcnt: 002560,003297
rdensty: 0300
notes: NONE

1 error(s), 0 warning(s), and 1 note(s) were encountered
in Raster File D001R011.

Saving Raster Header File: D001R011_HDR
Saving Raster Data File: D001R011_GR4

Found file: D001T012
Extracting SGML Text Header Records...
Evaluating SGML Text Header Records...

srcdocid: 33D5-49-46-1
dstdocid: NONE
*** ERROR (MIL-STD-1840A; 5.1.4.1) - Invalid value for 'dstdocid: '
*** NOTE (MIL-STD-1840A; 5.1.4.1) - The value must be the
Destination Organization's Document Number.
txtfilid: W
doccls: UNCLASSIFIED
notes: NONE

1 error(s), 0 warning(s), and 1 note(s) were encountered
in SGML Text File D001T012.

Saving SGML Text Header File: D001T012_HDR
Saving SGML Text Data File: D001T012_TXT

Evaluating Document D001 numbering scheme...

No errors were encountered during numbering scheme evaluation.
Numbering scheme evaluation complete.

Checking Document D001 file count...
No errors were encountered during file count verification.
File Count verification complete.

A total of 14 error(s), 0 warning(s), and 14 note(s) were
encountered in Document D001.

A grand total of 14 error(s), 0 warning(s), and 14 note(s) were
encountered in File Set Set003.

9.4 Other Tape Reading Logs

No reported errors from XSoft CAPS read1840A utility.

10. Appendix B - Detailed Raster Analysis

10.1 File D001R010

10.1.1 Output Preview

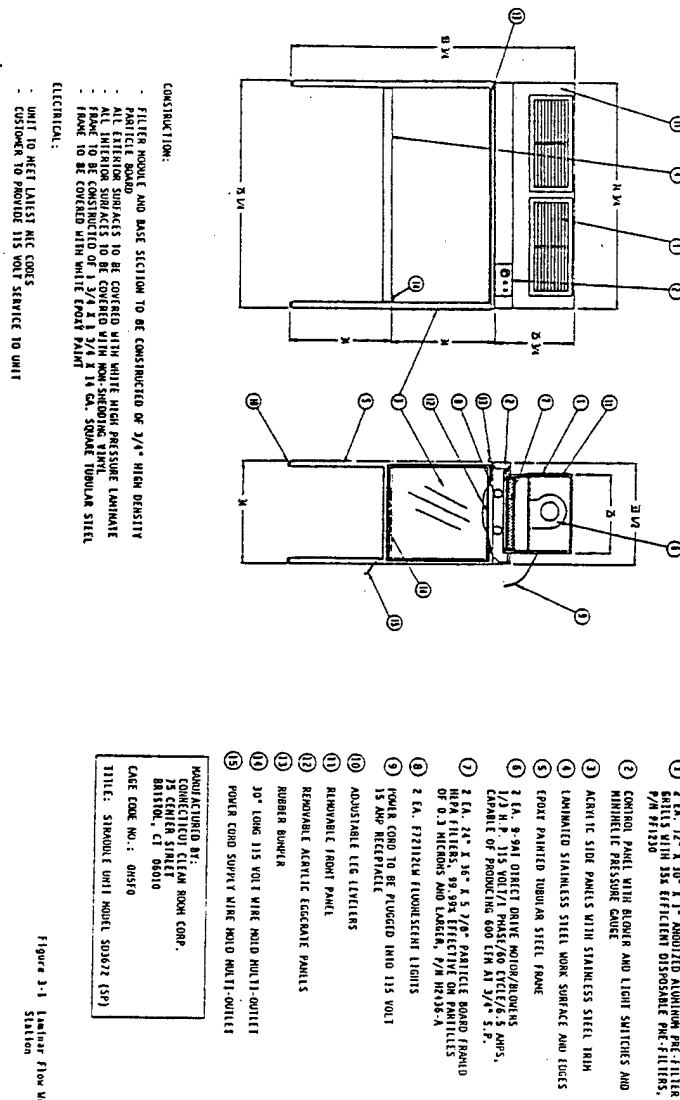

10.1.2 Output HiJaak for Windows

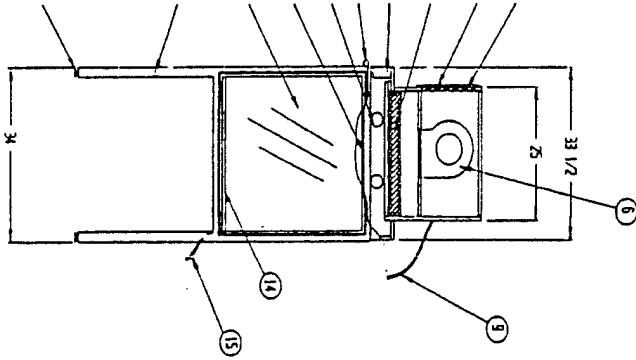

- ① 2 EA., 12" X 30" X 1" ANODIZED ALUMINUM PRE-FILTER GRILLS WITH 35% EFFICIENT DISPOSABLE PRE-FILTERS, P/N PF1230
- ② CONTROL PANEL WITH BLOWER AND LIGHT SWITCHES AND MINIHELIC PRESSURE GAUGE
- ③ ACRYLIC SIDE PANELS WITH STAINLESS STEEL TRIM
- ④ LAMINATED STAINLESS STEEL WORK SURFACE AND EDGES
- ⑤ EPOXY PAINTED TUBULAR STEEL FRAME
- ⑥ 2 EA., 9-9AT DIRECT DRIVE MOTOR/BLOWERS 1/3 H.P., 115 VOLT/1 PHASE/60 CYCLE/5.5 AMPS, CAPABLE OF PRODUCING 600 CFM AT 3/4" S.P.
- ⑦ 2 EA., 24" X 36" X 5 7/8" PARTICLE BOARD FRAMED HEPA FILTERS, 99.99% EFFECTIVE ON PARTICLES OF 0.3 MICRONS AND LARGER, P/N H2436-A
- ⑧ 2 EA., F72T12CW FLUORESCENT LIGHTS
- ⑨ POWER CORD TO BE PLUGGED INTO 115 VOLT 15 AMP RECEPTACLE
- ⑩ ADJUSTABLE LEG LEVELERS
- ⑪ REMOVABLE FRONT PANEL
- ⑫ REMOVABLE ACRYLIC EGGRATE PANELS
- ⑬ RUBBER BUMPER
- ⑭ 30" LONG 115 VOLT WIRE MOLD MULTI-OUTLET
- ⑮ POWER CORD SUPPLY WIRE MOLD MULTI-OUTLET

MANUFACTURED BY:
CONNECTICUT CLEAN ROOM CORP.
75 CENTER STREET

10.1.3 Output IGESView

TO 33D5-49-46-1

TECHNICAL MANUAL
OPERATION AND MAINTENANCE INSTRUCTIONS
LAMINAR FLOW
WORK STATION

(CTI Cryogenics)
(A Division of Helix Technology Corporation)

(COMMERCIAL MANUAL No. M8040299)

CONTRACT NO. F33657-84-C-0004

DISTRIBUTION STATEMENT.

Distribution authorized to Department of Defense and US DOD contractors only; Critical Technology, 8 Sep 87. Other requests for this document shall be referred to WR-ALC/LY-1, Robins AFB, GA 31098-5609

WARNING

This document contains technical data whose export is restricted by the Arms Export Control Act (Title 22, U.S.C., Sec 2751 et seq.) or the Export Administration Act of 1979, as amended (Title 50, U.S.C., app. 2401 et seq.). Violators of these export laws are subject to severe criminal penalties.

HANDLING AND DESTRUCTION NOTICE

Destroy by any method that will prevent disclosure of contents or reconstruction of the document.

THIS MATERIAL MAY BE REPRODUCED BY OR FOR THE US GOVERNMENT
PURSUANT TO THE COPYRIGHT LICENSE UNDER THE (DFAR) CLAUSE AT
52.227-7013 (15 MAY 1987).

Published under authority of the Secretary of the Air Force

NOVEMBER 1991
REVISED FEBRUARY 1992

10.1.4 Output HiJaak/Ventura Publisher

TO 33D5-49-46-1

TECHNICAL MANUAL
OPERATION AND MAINTENANCE INSTRUCTIONS
**LAMINAR FLOW
WORK STATION**

(CTI Cryogenics)
(A Division of Helix Technology Corporation)
(COMMERCIAL MANUAL No. M8040299)

CONTRACT NO. F33657-84-G-0004

DISTRIBUTION STATEMENT

Distribution authorized to Department of Defense and US DOD contractors only; Critical Technology, 8 Sep 87. Other requests for this document shall be referred to WR-ALC/LY-1, Robins AFB, GA 31098-5609

WARNING

This document contains technical data whose export is restricted by the Arms Export Control Act (Title 22, U.S.C., Sec 2751 et seq.) or the Export Administration Act of 1979, as amended (Title 50, U.S.C., app. 2401 et seq.). Violators of these export laws are subject to severe criminal penalties.

HANDLING AND DESTRUCTION NOTICE

Destroy by any method that will prevent disclosure of contents or reconstruction of the document.

THIS MATERIAL MAY BE REPRODUCED BY OR FOR THE US GOVERNMENT PURSUANT TO THE COPYRIGHT LICENSE UNDER THE (DFAR) CLAUSE AT 52.227-7013 (15 MAY 1987).

Published under authority of the Secretary of the Air Force

NOVEMBER 1991
REVISED FEBRUARY 1992

OPERATION AND MAINTENANCE INSTRUCTIONS
FOR THE
LAMINAR FLOW WORK STATION

M8040299

November 1991
Revised February 1992

SUBMITTED TO:
MARTIN MARIETTA ORLANDO AEROSPACE
ELECTRONICS SYSTEMS CENTER
ORLANDO, FLORIDA 32862-8007

IN RESPONSE TO:
CONTRACT NUMBER 67600C

BY
CTI-CRYOGENICS
A DIVISION OF HELIX TECHNOLOGY CORPORATION
266 SECOND AVENUE
WALTHAM, MASSACHUSETTS 02154

TABLE OF CONTENTS

<u>Section</u>		<u>Page</u>
	LIST OF ILLUSTRATIONS	iii
	LIST OF TABLES	iii
	SAFETY SUMMARY	iv
	FOREWORD	v
1.0	INTRODUCTION	1-1
	1.1 GENERAL INFORMATION	1-1
	1.2 CUSTOMER-SUPPLIED CONSUMABLES	1-1
	1.3 AMBIENT CONDITIONS	1-1
	1.4 EQUIPMENT SPECIFICATIONS	1-1
2.0	DESCRIPTION OF EQUIPMENT	2-1
3.0	OPERATING INSTRUCTIONS	3-1
	3.1 GENERAL INFORMATION	3-1
	3.2 OPERATING PROCEDURE	3-1
4.0	MAINTENANCE INSTRUCTIONS	4-1

LIST OF ILLUSTRATIONS

<u>Figure</u>		<u>Page</u>
3-1	Laminar Flow Work Station.	3-2

LIST OF TABLES

<u>Table</u>		<u>Page</u>
4-1	MAINTENANCE REQUIREMENTS.	4-1

FOREWORD

PURPOSE

This technical order provides operation and maintenance instructions for the Laminar Flow Work Station (Figure 3-1).

SCOPE

This technical order contains operation and maintenance instructions for depot maintenance of the Laminar Flow Work Station. These instructions include procedures on how to operate and maintain the station.

ARRANGEMENT

This technical order is arranged in four sections:

- Section 1.0 Introduction includes ambient conditions and equipment specifications;
- Section 2.0 Description of Equipment
- Section 3.0 Operating Instructions, contains a figure showing components of the Laminar Flow Work Station
- Section 4.0 Maintenance Instructions, covers periodic maintenance requirements for the Laminar Flow Work Station

SECTION 1.0

INTRODUCTION

1.1 GENERAL INFORMATION

The Laminar Flow Work Station provides a clean, Class 100 work environment for all critical subassembly and final assembly operations.

1.2 CUSTOMER-SUPPLIED CONSUMABLES

There are no customer-supplied consumables required for the Laminar Flow Work Station.

1.3 AMBIENT CONDITIONS

It is recommended that the following ambient conditions be met in the area where the Laminar Flow Work Station is located.

- Temperature: 72 ± 8°F (22 ± 5°C)
- Humidity: Less than 50% relative humidity
- Flooring: Tiled, in order to minimize dust

1.4 EQUIPMENT SPECIFICATIONS

The specifications for the Laminar Flow Work Station are as follows:

Dimensions of the Laminar Flow Work Station:

Length	75.25 in. (191.14 cm)
Width (Depth)	34.00 in. (86.36 cm)
Height	93.75 in. (238.13 cm)

Electrical power requirements:

Four (4) 115 VAC, 60 Hz, 15 Amp, circuits (2 per station)

SECTION 2.0
DESCRIPTION OF EQUIPMENT

2.1 GENERAL INFORMATION

The Laminar Flow Work Station frame, shown in Figure 3-1, is constructed of 14-gauge square tubular steel covered with white epoxy paint. The work surface is constructed of 3/4-inch high density particle board covered with stainless steel to provide a clean and durable work surface. Each work station contains two fluorescent lights, a multi-outlet strip, a pre-filter and final filter system with a blower capable of delivering 900 cubic feet of air per minute. Each Laminar Flow Work Station shall meet Class 100 "clean work station" requirements of Federal Standard 209B. The Laminar Flow Work Station will provide a clean working surface free of any particulate contamination which could adversely affect the performance of the LANTIRN Cooler.

SECTION 3.0
OPERATING INSTRUCTIONS

3.1 GENERAL INFORMATION

The Laminar Flow Work Station is designed for continuous operation except for periodic maintenance outlined in Section 4.0.

3.2 OPERATING PROCEDURE

1. Turn blow switch to ON position (refer to 2, Figure 3-1).

Note

The Laminar Flow Work Station should be left ON (blower running) at all times during working hours. If the blower switch is turned OFF, the Laminar Flow Work Station should be operated a minimum of 15 minutes before being utilized.

2. Turn light switch to ON position.

Note

The light switch may be turned ON or OFF as required during working hours.

- ① 2 EA. 12" X 30" X 1" ANODIZED ALUMINUM PRE-FILTER GRILLS WITH 35% EFFICIENT DISPOSABLE PRE-FILTERS, P/N PF1230
- ② CONTROL PANEL WITH BLOWER AND LIGHT SWITCHES AND MINIHILIC PRESSURE GAUGE
- ③ ACRYLIC SIDE PANELS WITH STAINLESS STEEL TRIM
- ④ LAMINATED STAINLESS STEEL WORK SURFACE AND EDGES
- ⑤ EPOXY PAINTED TUBULAR STEEL FRAME
- ⑥ 2 EA. 9-90T DIRECT DRIVE MOTOR/BLOWERS 1/3 H.P., 115 VOLT/1 PHASE/60 CYCLE/6.5 AMPS, CAPABLE OF PRODUCING 600 CFM AT 3/4" S.P.
- ⑦ 2 EA. 24" X 36" X 5 7/8" PARTICLE BOARD FRAMED HEPA FILTERS, 99.99% EFFECTIVE ON PARTICLES OF 0.3 MICRONS AND LARGER, P/N H2436-A
- ⑧ 2 EA. F72T12CM FLUORESCENT LIGHTS
- ⑨ POWER CORD TO BE PLUGGED INTO 115 VOLT 15 AMP RECEPTACLE
- ⑩ ADJUSTABLE LEG LEVELERS
- ⑪ REMOVABLE FRONT PANEL
- ⑫ REMOVABLE ACRYLIC EGGERATE PANELS
- ⑬ RUBBER BUMPER
- ⑭ 30" LONG 115 VOLT WIRE MOLD MULTI-OUTLET
- ⑮ POWER CORD SUPPLY WIRE MOLD MULTI-OUTLET

MANUFACTURED BY:
CONNECTICUT CLEAN ROOM CORP.
75 CENTER STREET
BRISTOL, CT 06010
CAGE CODE NO.: ONSFO
TITLE: STRADDLE UNIT MODEL SD3672 (SP)

Figure 3-1 Laminar Flow Work Station

3-2

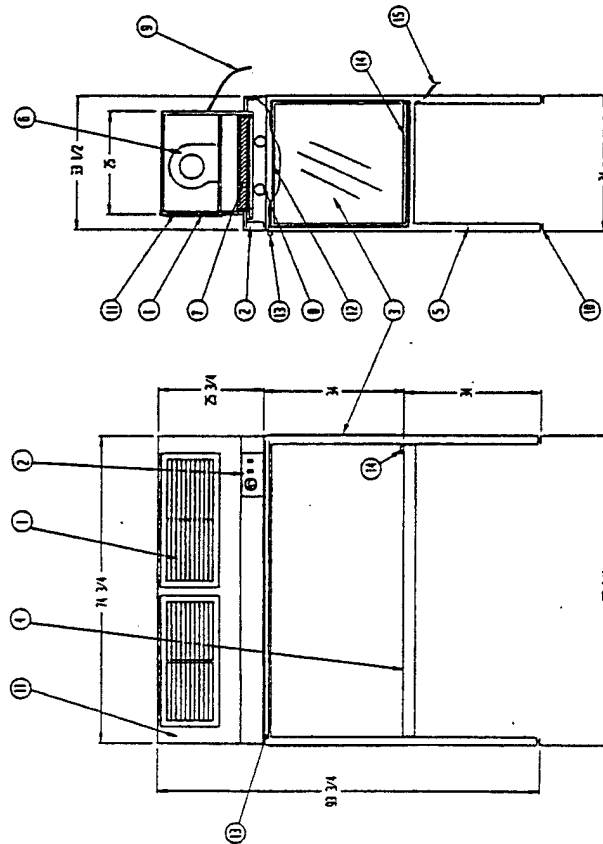

CONSTRUCTION:

- FILTER MODULE AND BASE SECTION TO BE CONSTRUCTED OF 3/4" HIGH DENSITY PARTICLE BOARD
- ALL EXTERIOR SURFACES TO BE COVERED WITH WHITE HIGH PRESSURE LAMINATE
- ALL INTERIOR SURFACES TO BE COVERED WITH NON-SHEDDING VINYL
- FRAME TO BE CONSTRUCTED OF 1 3/4 X 1 3/4 X 14 GA. SQUARE TUBULAR STEEL
- FRAME TO BE COVERED WITH WHITE EPOXY PAINT

ELECTRICAL:

- UNIT TO MEET LATEST NEC CODES
- CUSTOMER TO PROVIDE 115 VOLT SERVICE TO UNIT

SECTION 4.0
MAINTENANCE INSTRUCTIONS

The maintenance requirements of the Laminar Flow Work Station are presented in Table 4-1.

WARNING

BEFORE PERFORMING ANY MAINTENANCE, DISCONNECT POWER AND ALLOW THE MOTOR TO COME TO A COMPLETE STOP.

Note

The maintenance requirements listed in Table 4-1 are intended as a guide only and may change to a schedule consistent with User experience.

TABLE 4-1
MAINTENANCE REQUIREMENTS

COMPONENT (REFER TO FIGURE 3-1)	MAINTENANCE REQUIREMENTS
1. Pre-Filter	1. The pre-filter should be changed on a monthly basis.
2. Electric Motor	2. Relubricate once a year with 30-35 drops of SAE #20 non-detergent oil.
3. Blower	3. Remove dirt from blower and housing by vacuuming once a month.
4. HEPA Filter	4. The operational efficiency of the Laminar Flow Work Station should be verified and certified a minimum of once a year by an outside testing laboratory and the HEPA filter replaced as necessary.