

LOAN DOCUMENT

PHOTOGRAPH THIS SHEET

DTIC ACCESSION NUMBER

LEVEL

INVENTORY

WL-TR-96-2086

DOCUMENT IDENTIFICATION

DISTRIBUTION STATEMENT R

Approved for public release
Distribution Unlimited

DISTRIBUTION STATEMENT

ACCESSION FOR	
NTIS	GRAB
DTIC	TRAC
UNANNOUNCED	
JUSTIFICATION	
BY	
DISTRIBUTION/	
AVAILABILITY CODES	
DISTRIBUTION	AVAILABILITY AND/OR SPECIAL
A-1	

DISTRIBUTION STAMP

DTIC QUALITY INSPECTED 1

A-1 19960812 165

DATE RECEIVED IN DTIC

DATE ACCESSIONED

DATE RETURNED

REGISTERED OR CERTIFIED NUMBER

PHOTOGRAPH THIS SHEET AND RETURN TO DTIC-FDAC

H
A
N
D
L
E

W
I
T
H

C
A
R
E

WL-TR-96-2086



HIGH-RESOLUTION DIGITAL TWO-COLOR PIV (D2CPIV) AND ITS APPLICATION TO HIGH FREESTREAM TURBULENT FLOWS

**R. Rivir
S. Gogineni
D. Trump
L. Goss
D. Pestian**

DECEMBER 16, 1995

FINAL REPORT 1 NOVEMBER 1995--9 JULY 1996

Approved for public release; distribution unlimited

**AERO PROPULSION & POWER DIRECTORATE
WRIGHT LABORATORY
AIR FORCE MATERIEL COMMAND
WRIGHT-PATTERSON AIR FORCE BASE, OH 45433-7650**

This paper is declared a work of the U.S. Government and as such is not subject to copyright protection in the United States

NOTICE

WHEN GOVERNMENT DRAWINGS, SPECIFICATIONS, OR OTHER DATA ARE USED FOR ANY PURPOSE OTHER THAN IN CONNECTION WITH A DEFINITELY GOVERNMENT-RELATED PROCUREMENT, THE UNITED STATES GOVERNMENT INCURS NO RESPONSIBILITY OR ANY OBLIGATION WHATSOEVER. THE FACT THAT THE GOVERNMENT MAY HAVE FORMULATED OR IN ANY WAY SUPPLIED THE SAID DRAWINGS, SPECIFICATIONS, OR OTHER DATA, IS NOT TO BE REGARDED BY IMPLICATION, OR OTHERWISE IN ANY MANNER CONSTRUED, AS LICENSING THE HOLDER, OR ANY OTHER PERSON OR CORPORATION; OR AS CONVEYING ANY RIGHTS OR PERMISSION TO MANUFACTURE, USE, OR SELL ANY PATENTED INVENTION THAT MAY IN ANY WAY BE RELATED THERETO.

THIS REPORT IS RELEASABLE TO THE NATIONAL TECHNICAL INFORMATION SERVICE (NTIS). AT NTIS, IT WILL BE AVAILABLE TO THE GENERAL PUBLIC, INCLUDING FOREIGN NATIONS.

THE TECHNICAL REPORT HAS BEEN REVIEWED AND IS APPROVED FOR PUBLICATION.



RICHARD B. RIVIR
Manager, Aerothermal Research
Turbine Branch
Turbine Engine Division
Aero Propulsion & Power Directorate



CHARLES D. MACARTHUR
Chief
Turbine Branch
Turbine Engine Division
Aero Propulsion & Power Directorate



RICHARD J. HILL
Chief of Technology
Turbine Engine Division
Aero Propulsion & Power Directorate

IF YOUR ADDRESS HAS CHANGED, IF YOU WISH TO BE REMOVED FROM OUR MAILING LIST, OR IF THE ADDRESSEE IS NO LONGER EMPLOYED BY YOUR ORGANIZATION PLEASE NOTIFY WL/POTT, WPAFB OH 45433-7650 TO HELP MAINTAIN A CURRENT MAILING LIST.

REPORT DOCUMENTATION PAGE

Form Approved
OMB No. 0704-0188

Public reporting burden for this collection of information is estimated to average 1 hour per response, including the time for reviewing instructions, searching existing data sources, gathering and maintaining the data needed, and completing and reviewing the collection of information. Send comments regarding this burden estimate or any other aspect of this collection of information, including suggestions for reducing this burden, to Washington Headquarters Services, Directorate for Information Operations and Reports, 1215 Jefferson Davis Highway, Suite 1204, Arlington, VA 22202-4302, and to the Office of Management and Budget, Paperwork Reduction Project (0704-0188), Washington, DC 20503.

1. AGENCY USE ONLY (Leave blank)	2. REPORT DATE December 16, 1996	3. REPORT TYPE AND DATES COVERED Final 1 Nov 95 - 9 Jul 96
---	--	--

4. TITLE AND SUBTITLE High Resolution Digital Two-Color PIV (D2CPIV) and its Application to High Freestream Turbulent Flows	5. FUNDING NUMBERS PE 61102F JON 2307S315
---	--

6. AUTHOR(S) R. Rivir, S. Gogineni, D. Trump, L. Goss, D. Pestian	
---	--

7. PERFORMING ORGANIZATION NAME(S) AND ADDRESS(ES) Aero Propulsion & Power Directorate Wright Laboratory Air Force Materiel Command Wright-Patterson Air Force Base, OH 45433-7650	8. PERFORMING ORGANIZATION REPORT NUMBER
---	---

9. SPONSORING / MONITORING AGENCY NAME(S) AND ADDRESS(ES) Aero Propulsion & Power Directorate Wright Laboratory Air Force Materiel Command Wright-Patterson Air Force Base, OH 45433-7650 POC: Richard B Rivir, WL/POTT, 513-255-5132	10. SPONSORING / MONITORING AGENCY REPORT NUMBER WL-TR-96-2086
---	--

11. SUPPLEMENTARY NOTES

12a. DISTRIBUTION / AVAILABILITY STATEMENT APPROVED FOR PUBLIC RELEASE; DISTRIBUTION IS UNLIMITED	12b. DISTRIBUTION CODE
---	-------------------------------

13. ABSTRACT (Maximum 200 words)

An extension of two-color Particle Image Velocimetry (PIV) is described in which the recording media (color film) is replaced with a high-resolution (3060 x 2036 pixel) color CCD sensor. Incorporation of the sensor eliminates the time associated with film development and digitization. Use of color allows the removal of directional ambiguities without resorting to polarization-based image-shifting techniques. For comparing the performance of the color CCD sensor with conventional color film. PI images were obtained on a sand-blasted surface undergoing a known translation and rotation under comparable lighting and camera conditions. Good agreement was obtained between the two recording media, indicating that the behavior of the color CCD sensor is similar to that of 400-ASA color film. This digital two-color PIV (D2CPIV) technique was used for studying simulated turbine film-cooling flows to obtain more detailed characterization of the coolant-injection phenomena and their interaction with freestream disturbances. This technique allowed near-real-time optimization of the PIV parameters which resulted in higher valid vector density and shear-layer resolution.

14. SUBJECT TERMS	15. NUMBER OF PAGES 13
	16. PRICE CODE

17. SECURITY CLASSIFICATION OF REPORT UNCLASSIFIED	18. SECURITY CLASSIFICATION OF THIS PAGE UNCLASSIFIED	19. SECURITY CLASSIFICATION OF ABSTRACT UNCLASSIFIED	20. LIMITATION OF ABSTRACT SAR
--	---	--	--

GENERAL INSTRUCTIONS FOR COMPLETING SF 298

The Report Documentation Page (RDP) is used in announcing and cataloging reports. It is important that this information be consistent with the rest of the report, particularly the cover and title page. Instructions for filling in each block of the form follow. It is important to *stay within the lines* to meet *optical scanning requirements*.

Block 1. Agency Use Only (Leave blank).

Block 2. Report Date. Full publication date including day, month, and year, if available (e.g. 1 Jan 88). Must cite at least the year.

Block 3. Type of Report and Dates Covered. State whether report is interim, final, etc. If applicable, enter inclusive report dates (e.g. 10 Jun 87 - 30 Jun 88).

Block 4. Title and Subtitle. A title is taken from the part of the report that provides the most meaningful and complete information. When a report is prepared in more than one volume, repeat the primary title, add volume number, and include subtitle for the specific volume. On classified documents enter the title classification in parentheses.

Block 5. Funding Numbers. To include contract and grant numbers; may include program element number(s), project number(s), task number(s), and work unit number(s). Use the following labels:

C - Contract	PR - Project
G - Grant	TA - Task
PE - Program Element	WU - Work Unit Accession No.

Block 6. Author(s). Name(s) of person(s) responsible for writing the report, performing the research, or credited with the content of the report. If editor or compiler, this should follow the name(s).

Block 7. Performing Organization Name(s) and Address(es). Self-explanatory.

Block 8. Performing Organization Report Number. Enter the unique alphanumeric report number(s) assigned by the organization performing the report.

Block 9. Sponsoring/Monitoring Agency Name(s) and Address(es). Self-explanatory.

Block 10. Sponsoring/Monitoring Agency Report Number. (If known)

Block 11. Supplementary Notes. Enter information not included elsewhere such as: Prepared in cooperation with...; Trans. of...; To be published in.... When a report is revised, include a statement whether the new report supersedes or supplements the older report.

Block 12a. Distribution/Availability Statement. Denotes public availability or limitations. Cite any availability to the public. Enter additional limitations or special markings in all capitals (e.g. NOFORN, REL, ITAR).

DOD - See DoDD 5230.24, "Distribution Statements on Technical Documents."

DOE - See authorities.

NASA - See Handbook NHB 2200.2.

NTIS - Leave blank.

Block 12b. Distribution Code.

DOD - Leave blank.

DOE - Enter DOE distribution categories from the Standard Distribution for Unclassified Scientific and Technical Reports.

NASA - Leave blank.

NTIS - Leave blank.

Block 13. Abstract. Include a brief (*Maximum 200 words*) factual summary of the most significant information contained in the report.

Block 14. Subject Terms. Keywords or phrases identifying major subjects in the report.

Block 15. Number of Pages. Enter the total number of pages.

Block 16. Price Code. Enter appropriate price code (*NTIS only*).

Blocks 17. - 19. Security Classifications. Self-explanatory. Enter U.S. Security Classification in accordance with U.S. Security Regulations (i.e., UNCLASSIFIED). If form contains classified information, stamp classification on the top and bottom of the page.

Block 20. Limitation of Abstract. This block must be completed to assign a limitation to the abstract. Enter either UL (unlimited) or SAR (same as report). An entry in this block is necessary if the abstract is to be limited. If blank, the abstract is assumed to be unlimited.

HIGH-RESOLUTION DIGITAL TWO-COLOR PIV (D2CPIV)
AND ITS APPLICATION TO HIGH FREESTREAM TURBULENT FLOWS

S. Gogineni and D. Trump
Systems Research Laboratories
2800 Indian Ripple Road
Dayton, OH 45440

R. Rivir
Wright Laboratory
Aero Propulsion and Power Directorate
Wright-Patterson AFB, OH 45433

L. Goss
Innovative Scientific Solutions, Inc.
3845 Woodhurst Ct.
Beavercreek, OH 45430

D. Pestian
University of Dayton Research Institute
300 College Park
Dayton, OH 45469

ABSTRACT

An extension of two-color Particle Image Velocimetry (PIV) is described in which the recording media (color film) is replaced with a high-resolution (3060 x 2036 pixel) color CCD sensor. Incorporation of the sensor eliminates the time associated with film development and digitization. Use of color allows the removal of directional ambiguities without resorting to polarization-based image-shifting techniques. For comparing the performance of the color CCD sensor with conventional color film, PIV images were obtained on a sand-blasted surface undergoing a known translation and rotation under comparable lighting and camera conditions. Good agreement was obtained between the two recording media, indicating that the behavior of the color CCD sensor is similar to that of 400-ASA color film. This digital two-color PIV (D2CPIV) technique was used for studying simulated turbine film-cooling flows to obtain more detailed characterization of the coolant-injection phenomena and their interaction with freestream disturbances. This technique allowed near-real-time optimization of the PIV parameters which resulted in higher valid vector density and shear-layer resolution.

NOMENCLATURE

d	film-cooling-hole diameter (1.905 cm)
R	coolant blowing (mass flux) ratio ($\rho_c U_c / \rho_m U_m$)
Re	Reynolds number based on film-cooling-hole diameter
Tu	turbulence intensity (u/U)
U	mean local streamwise velocity (m/s)
x	streamwise distance measured from the downstream lip of the injection hole (cm)
y	vertical distance from the injection surface (cm)

1. INTRODUCTION

The PIV technique has been in use for a number of years to measure velocity distributions in planar cross sections of aerodynamic flowfields (Adrian 1991). One of the difficulties involved in implementing this velocimetry technique is the 180-deg. directional ambiguity which results from the inability to determine the temporal sequence of the particle pairs. Several techniques have been developed to resolve this ambiguity problem; most involve imposing a shift between consecutive image exposures by means of scanning or rotating mirrors (Adrian 1986), pulse tagging (Grant and Liu 1990), calcite crystals (Landreth and Adrian 1988), or polarizing beam splitters (Lourenco 1993). For overcoming the difficulties inherent in these techniques, a two-color PIV system was developed (Goss et al. 1991). The advantages of this system are: 1) the directional ambiguity is resolved using the color coding of the particle images, which is inherent in the system, 2) higher data yields and signal-to-noise levels are attainable, and 3) the technique is suitable for both reacting and non-reacting flowfields.

In early experimental approaches involving the PIV technique, the particle images were recorded on photographic film. However, this type of recording is time consuming because of the need to develop the film before digitization and subsequent computer processing. This disadvantage can be overcome by recording the particle images directly onto a two-dimensional CCD array. This approach has been recognized by several investigators. Cho (1989) proposed that the double-exposed digital images be obtained by digitizing single-exposed video images and adding the successive images. Okada et al. (1990) used liquid-crystal television (LCTV) having a resolution of 320 x 320 pixels. Willert and Gharib (1991) developed digital PIV and used cross correlation of the original-image frames acquired in succession to obtain an accurate measurement of the

displacements without directional ambiguity. Lourenco et al. (1994) introduced a fully digital and operator-interactive PIV system which utilized a CCD area sensor (1320 x 1035 pixel), resulting in significant improvements over earlier CCD-based PIV systems. This system has been successfully implemented in a wide variety of flow regimes.

The extension of the two-color PIV technique to include CCD cameras has been hampered in the past by the lack of commercially available high-resolution color CCD camera systems. Goss et al. (1994) attempted to utilize a single CCD camera and dichroic mirror to record the two-color PIV images of a stagnation-point flow. However, several problems were encountered, including a nonuniform shift across the image and degraded signal-to-noise ratios. Because of recent developments in high-resolution color cameras, the difficulty in utilizing color CCD cameras for two-color PIV has significantly decreased.

The present paper describes the extension of two-color PIV by recording the color images onto a single, high-resolution, digital (3060 x 2036 pixel) color CCD sensor, thus eliminating the processing time and subsequent digitization time of color film and the complexities associated with conventional image-shifting techniques. For demonstrating the direction-resolving capabilities of the D2CPIV technique and evaluating the spatial resolution capabilities, a test was performed using a sand-blasted rotating wheel. Results from this study indicate that the high-resolution color CCD sensor is comparable to 400-ASA color film in sensitivity, spatial resolution, and data quality.

This D2CPIV technique was also used to study simulated turbine film-cooling flows in order to provide a more detailed characterization of the coolant-injection phenomena and their interaction with the freestream disturbances. These types of flows are important because many state-of-the-art turbine stages employ film cooling to permit near-stoichiometric combustor operating temperatures. Film-cooling air is injected through rows of small (0.5 - 0.8 mm diameter typical) holes in the blade surface. The coolant air is supplied from the compressor exit flow and is maintained at essentially constant pressure.

2. EXPERIMENTAL SETUP AND PROCEDURES

2.1 Facility Description

The open-loop film-cooling wind tunnel, as shown in Figure 1, has been described in detail by Bons et al. (1994, 1995). The main flow passes through a conditioning plenum containing perforated plates, honeycomb, screens, and a circular-to-rectangular transition nozzle. Downstream of the transition nozzle, at the location of the film-cooling station, low freestream turbulence levels of 0.7% (± 0.05) can be achieved, with velocity and temperature profiles being uniform to within 1% at the film-cooling station. High freestream turbulence levels up to 17% can be achieved at the film-cooling station. A single row of 1.905-cm film-cooling holes at an injection angle of 35 deg to the primary flow is investigated. The length-to-diameter ratio of the

film-cooling holes evaluated is 2.4. The ratio of integral turbulence scale to film-hole diameter is in the range 2.88 - 4.23, depending on the turbulence level and turbulence-generation mechanism (Bons et al. 1994). The ratio of momentum thickness to hole diameter typically is 0.05. The film-cooling-hole Reynolds numbers (Re) are 10,000, 20,000, and 40,000. The ratio of micro scale to film-hole diameter is in the range 0.1 - 0.39. The ratio of temperature or density of the film flow to the primary flow is typically in the range 1.07 - 1.09. The variation in blowing ratios ($R = 0.7 - 1.5$) is achieved effectively by varying the velocity ratio of the film-flow to the primary-flow velocity.

2.2 Two-Color PIV System

The two-color PIV system uses color for temporal marking of the seed particles in the flow field. The green (532-nm) laser output from a frequency-doubled Nd:YAG laser and the red (640-nm) laser output from a Nd:YAG-pumped dye laser (DCM dye) are combined by a dichroic beam splitter and directed through sheet-forming optics. The laser-sheet energy is typically 20 mJ/pulse, with a thickness of < 1 mm at the test section. The temporal delay between the two lasers is a function of gas velocity, optical magnification, and interrogation spot size. In the present

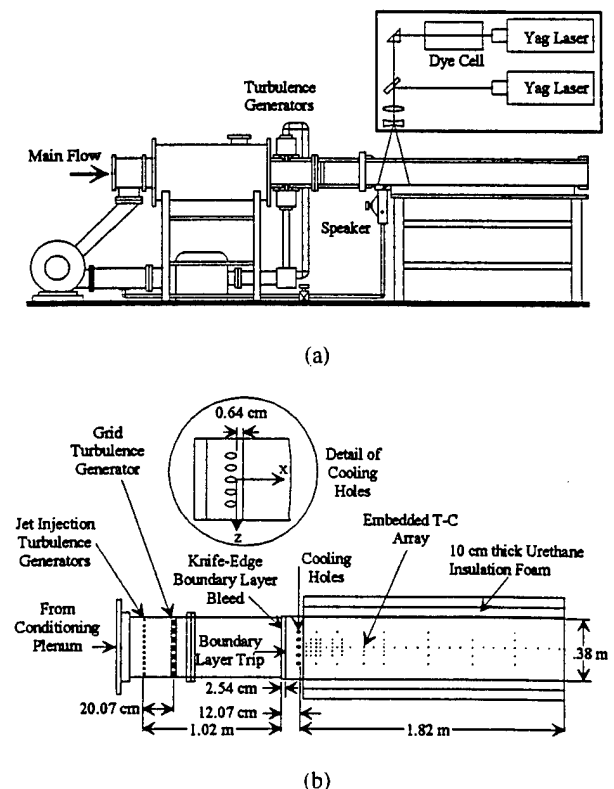

Fig. 1 Schematic diagram of experimental setup. (a) side view, (b) top view.

experiments, the time delay between the two color lasers is set at 10 μ sec for flows at $Re = 40,000$.

The film-cooling flow is seeded with sub-micron size particles, and the Mie scattering from the seed particles is recorded on a Kodak DCS 460 CCD array. This CCD sensor has a resolution of 3060 x 2036 pixels, and each pixel is 9 μ m square. The CCD camera has a built-in 12-bit analog-to-digital converter for increased dynamic range and a frame rate of 1 frame/sec. It also features a PC-MCIA storage drive which delivers about 26 exposures, with each PIV image occupying ~ 18 Mbytes. A 105-mm micro lens with an f-number 5.6 is used to record the images.

The color response of the DCS 460 CCD array is accomplished by overlaying the individual pixels of the camera with a series of red, green, and blue color filters. The green- and red-laser outputs are situated near the peak of the transmission of the green and red camera filters, respectively. Because the camera was built to respond, in part, as a human eye to color, most of the pixels are green-sensitive. The relative percentages of green, blue, and red pixels are 50%, 25%, and 25% respectively. The distribution of the red and blue pixels is random for minimizing straight-edge effects. The output from the camera controller to the computer is a 24-bit RGB tiff image; thus, the 12-bit ADC camera output must be mapped into three 8-bit colors, each having a spatial resolution equivalent to the chip size (3060 x 2036). This is accomplished through proprietary software developed by Kodak which involves interpolation to increase the spatial resolution of the camera. Because of the proprietary nature of this interpolation software, it was not known whether the resulting resolution of the color camera would be sufficient for accurate PIV measurements. This study was also directed toward evaluation and demonstration of the use of the Kodak color CCD camera for PIV studies.

2.3 Data Analysis

Once the PIV image has been captured and digitized, the velocity field is obtained using a cross-correlation technique. To improve the analysis of the seeded flow field, the output of the linear camera was convolved with a logarithm-like function prior to cross-correlation analysis. The present cross-correlation technique is based on intensity maps of the red and green images of the scattered light.

Consider the intensity distributions of the red and green images $r(x,y)$ and $g(x,y)$ and their corresponding Fourier transforms $R(\alpha,\beta)$ and $G(\alpha,\beta)$. The two-dimensional cross-correlation function

$$\begin{aligned} h(x,y) &= \int_R \int_R r(\alpha,\beta) g(x+\alpha,y+\beta) d\alpha d\beta \\ &= F^{-1} [F(r(x,y)) F^*(g(x,y))] \\ &= F^{-1} [R(\alpha,\beta) G^*(\alpha,\beta)] \end{aligned} \quad (1)$$

is employed to determine the magnitude and direction of the average velocity over the interrogation area. (Note that unlike in processing methodologies that are based on autocorrelation, the direction of the velocity vectors is uniquely determined.)

The correlation function is calculated over small segments (interrogation domains) of the PIV image. The dimensions of each interrogation domain are dependent on particle density, estimated local velocity gradients, particle-image size, and desired spatial resolution. The maximum displacement of each particle must be less than one-half the interrogation spot. In the present experiments, the interrogation domain measured 64 x 64 pixels, corresponding to 2 x 2 mm in the measured flow. For enhancing the overall resolution, the interrogation domains are overlapped by one-half the domain size. The peak of the correlation map corresponds to the average velocity displacement within the interrogation spot. An intensity-weighted peak-searching routine is used to determine the exact location of the peak to sub-pixel accuracy. The number of particle pairs normally necessary to ensure a desirable signal-to-noise ratio is reduced to four or five pairs when the cross-correlation analysis is employed.

2.4 Uncertainty Analysis

The experimental uncertainties are calculated based on knowledge of the instrumentation used and a simple root-mean-square error analysis (Kline and McClintock 1953). This method assumes that contributions to uncertainties arise mainly from unbiased and random sources. Uncertainty in the velocity measurement arises from the time required to keep the large out-of-plane velocities and fluctuating components within the laser sheet during both pulses. The resulting number of pixels, typically 10, of displacement and the sub-pixel resolution of 0.1 pixels then dictate the uncertainty of $\pm 1\%$. The spatial resolution in the data presented is 4 mm. The data are acquired at a resolution of 2.0 mm using 32 pixels/mm for a spatial-resolution accuracy of ~ 0.3%.

3. RESULTS AND DISCUSSION

3.1 Calibration of the System

For testing the ability of the color CCD camera to capture images of sufficient quality for PIV analysis and for demonstrating the directional resolving ability of the two-color PIV system, "calibration" displacements were obtained by recording the speckle patterns from a sand-blasted surface undergoing uniform translation and rotation. The output from the green and red lasers was sent unexpanded onto a scattering plate which diffusely scattered the light onto the sand-blasted surface. In the case of uniform translation, the displacements for each translation were generated by recording the single-exposed digital image (green at the initial position and red after a small translation) and then numerically adding the two images. Extreme care was taken to prevent any movement of the camera or the stage between exposures. Cross-correlation analysis was employed to process these images using a 64 x 64 pixel interrogation size. The processed translation data which contain about 6000 vectors showed uniform displacements throughout the

interrogation region, and the rms value of the translational horizontal component was found to be 0.011 mm. The displacements for the uniform rotational case were generated by spinning the wheel and exposing the speckle pattern from both green and red lasers on the same frame. Figure 2(a) shows a typical speckle pattern of the rotational image, and Figure 2(b) shows the velocity data which clearly indicate the ability of the two-color approach to resolve the directional ambiguity. In order to compare results obtained with the color CCD sensor and film, a line passing through the

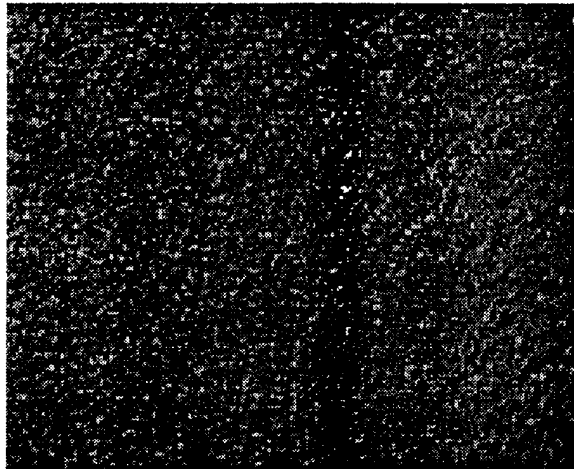

(a)

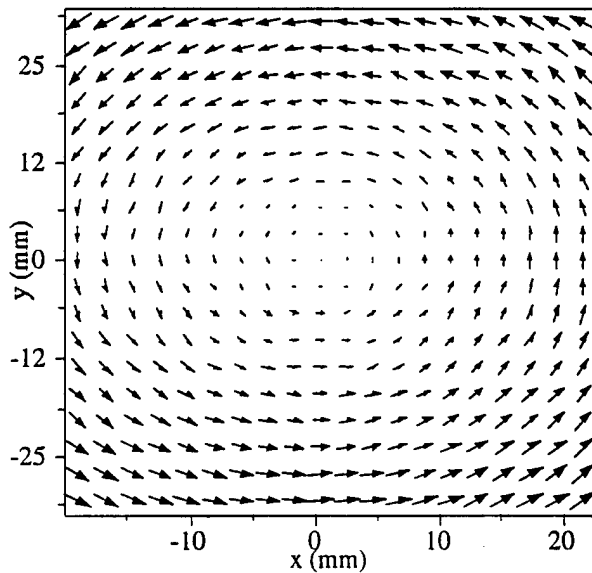

(b)

Fig. 2 Rotational data showing the direction-resolving capability of the D2CPIV technique. (a) speckle pattern, (b) velocity field

center of rotation with zero horizontal displacement was examined. Because the tangential velocity of a rigid body undergoing rotation varies directly with the radial distance from its center and its rotational speed, a simple deterministic relationship exists between the actual and measured velocities. Velocity measurements were obtained using both the color CCD sensor and color film (400 ASA) under identical conditions such as magnification, recording lens, aperture, and rotational speed. The film image was digitized at a resolution of 2700 pixels/in., yielding an image size of $\sim 3000 \times 2000$ pixels.

These images were interrogated using spot sizes ranging from 32×32 to 256×256 pixels. Figure 3 shows a comparison of the actual and measured velocities for both film and CCD sensor, with the images being processed using a 128×128 spot size. This shows that the data obtained using the high-resolution CCD sensor are very comparable to the film data. The proprietary interpolation software developed by Kodak appears to be effective in maintaining equal red, green, and blue pixel spatial resolution, even though the color pixels are not distributed equally through the color CCD sensor.

3.2 Application to Simulated Turbine Film-Cooling Flows

For further demonstrating the ability of the system to capture the complex flow features in quantitative form, simulated turbine film-cooling flows were considered. These flows occur in a very hostile, unsteady environment where velocity and temperature disturbances exceed 20%. The freestream and film-cooling wall conditions in these flows exceed those encountered in a classical, fully turbulent boundary layer. Accurate modeling of these flows has proved to be difficult due to the high-level unsteadiness. These flows have been investigated by Gogineni et al.

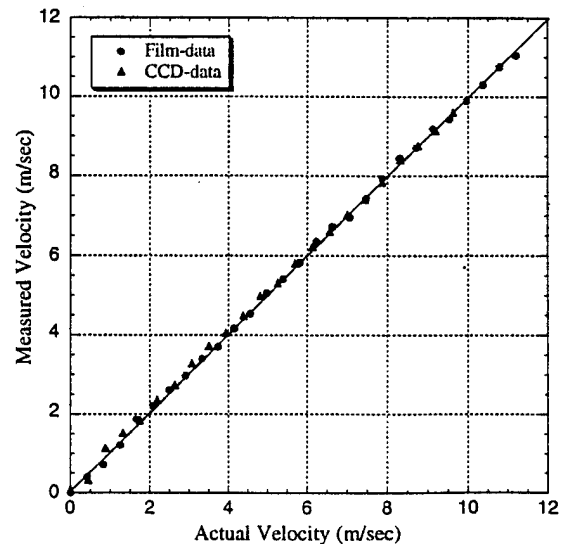

Fig. 3 Comparison of film and CCD data

(1995, 1996) using the conventional two-color PIV technique for $Re = 20,000$, with R varying from 0.5 to 1.5 and Tu from 1 to 17%. It was shown that turbulence clearly increases the film spread for $R = 0.7$. It was also observed that a linear relationship exists between the jet-exit slopes and both Tu and R for $R < 1.0$.

In the present study PIV measurements were made using a CCD sensor for $Re = 10,000$, 20,000, and 40,000 at freestream Tu levels of 1 and 17% by varying R from 0.7 to 1.5. These flow conditions were selected to understand the influence of high Reynolds number and high freestream turbulence on film-cooling effectiveness. Since the instantaneous realizations are not representative of mean flow behavior, 10 images were recorded for each condition. Figures 4(a) - 4(c) show typical double-exposed, two-color PIV images for $R = 0.7$ and $Tu = 1\%$ as Re is varied from 10,000 to 40,000. In these photographs, only the film-cooling flow is seeded with sub-micron size particles. When Re is increased, the shear-layer frequency over the film hole increases dramatically. The dominance of the film hole in setting the shear layer frequency over the film hole is reduced to 0.75 of the film hole diameter as Re is increased to 40,000. In all three photographs, a second, parallel shear layer is detected in the leading-edge exit region. This can be associated with separation from the inside entrance lip of the film-cooling hole. The shear-layer roll up is observed to be opposite that which would be expected for $R = 0.7$. The observed roll up results from the film tube boundary layer and a lack of seeding in the freestream. Figures 4(d) - 4(f) show the corresponding instantaneous velocity distributions. For clarity purposes, only a few of the measured vectors are shown in each frame.

Figures 5(a) - 5(c) show the PIV images when R is increased to 1.5 and Tu to 17%. At $R = 1.5$, the scale of the shear layer after the film-cooling hole increases or the frequency decreases as compared to $R = 0.7$ in Figure 4. Figures 5(d) - 5(f) show the corresponding instantaneous velocity distributions. The CCD digitization allowed near-real-time optimization of the seeding and laser-sheet intensities which resulted in higher valid vector density and shear-layer resolution.

4. CONCLUSIONS

A new implementation of the two-color PIV technique is described where conventional color film is replaced with a high-resolution color CCD sensor. The proprietary interpolation software developed by Kodak is effective in maintaining equal red, green, and blue pixel spatial resolution, even though the pixels are not equally distributed. It was determined that optimum results in seeded flow fields are obtained by applying a logarithm-like function to the camera image prior to cross-correlation analysis. Tests on a rotating wheel showed the directional-resolving capabilities of the two-color approach, and the system was successfully applied under simulated turbine-flow conditions. The CCD

sensor contributed significant improvement to the optimization of seeding and laser-sheet intensities for the simulated turbine high freestream flows.

ACKNOWLEDGMENTS

This work was performed under partial sponsorship of the Air Force Office of Scientific Research Project 2307S, with Dr. James McMichael as program manager. The work was also supported by Wright Laboratory, Aero Propulsion and Power Directorate, Wright-Patterson Air Force Base, Ohio, under USAF Contract Nos. F33615-90-C-2033 (with SRL) and F33615-95-C-2507 (with ISSI). The editorial assistance of Marian Whitaker (ISSI) is greatly appreciated.

REFERENCES

- Adrian, R. J. 1991, Particle Imaging Techniques for Experimental Fluid Mechanics, *Ann. Rev. Fluid Mech.*, vol. 23, pp. 261-304.
- Adrian, R. J. 1986, Image Shifting Technique to Resolve Directional Ambiguity in Double Pulsed Velocimetry, *Appl. Opt.*, vol. 25, no. 21, pp. 3855-3858.
- Bons, J., MacArthur, C. and Rivir, R. 1994, The Effect of High Free Stream Turbulence on Film Cooling Effectiveness, ASME Paper No. 94-GT-51, 39th International Gas Turbine and Aeroengine Congress and Exposition, The Hague, Netherlands.
- Bons, J., Rivir, R., Mac Arthur, C. and Pestian, D. 1995, The Effect of Unsteadiness on Film Cooling Effectiveness, AIAA Paper No. 95-0306, 33rd Aerospace Sciences Meeting and Exhibit, Reno NV.
- Cho, Y. C. 1989, Digital Image Velocimetry, *Appl. Opt.* vol. 28, pp. 740-748.
- Gogineni, S., Rivir, R., Pestian, D. and Goss, L. 1996, PIV Measurements of Flat Plate Film-Cooling Flows with High Freestream Turbulence, AIAA Paper No. 96-0617, 34th Aerospace Sciences Meeting and Exhibit, Reno, NV.
- Gogineni, S., Rivir, R., Pestian, D. and Goss, L. 1995, High Freestream Turbulence Influence on Turbine Film-Cooling Flows. Winner of the 13th Annual Fluid Mechanics Gallery of Fluid Motion Photo Contest, 48th APS/DFD Annual Meeting, Irvine, CA (to appear in a special issue of *Phys. Fluids*, September 1996).
- Goss, L. P., Post, M. E., Trump, D. D. and Sarka, B. 1991, Two-Color Particle-Image Velocimetry, *J. Laser Appl.*, vol. 3, pp. 36-42.

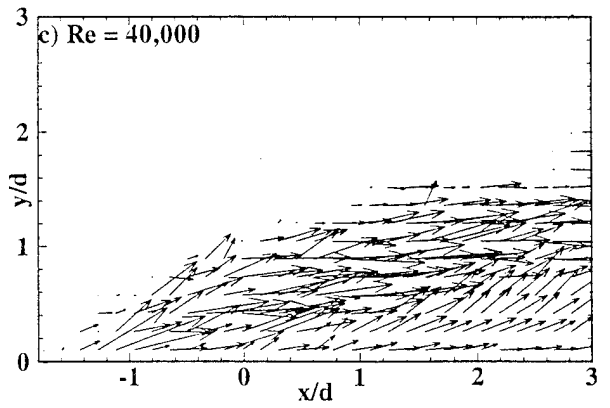
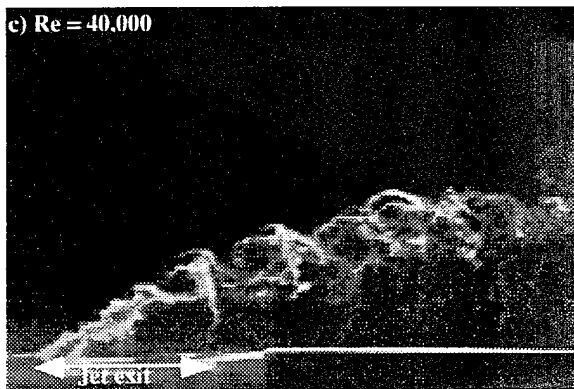
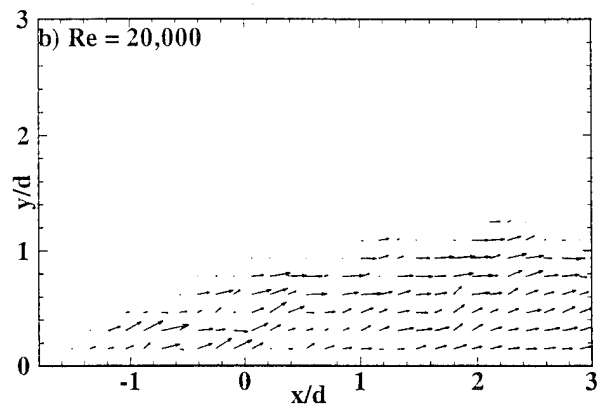
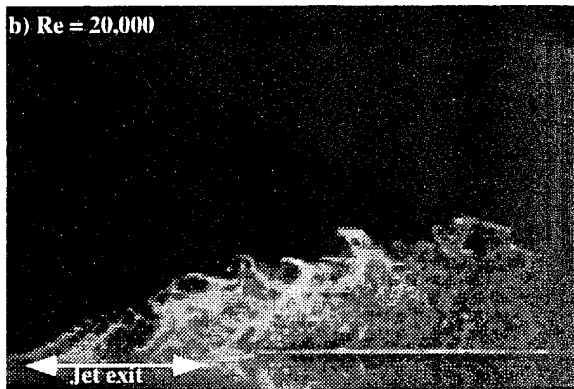
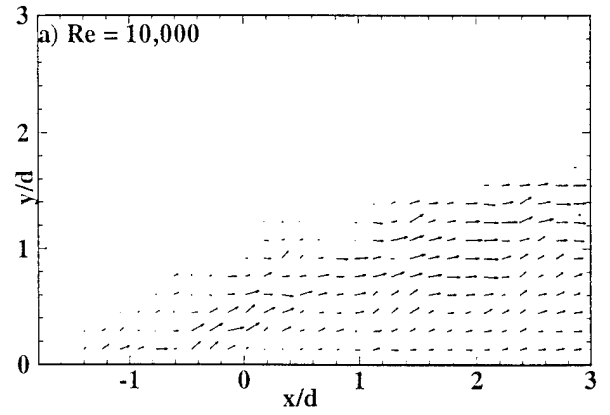
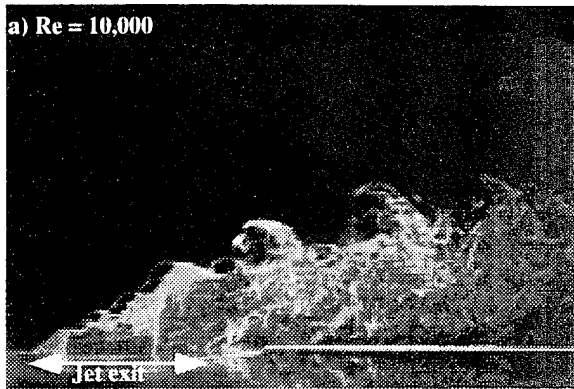

Double exposed PIV images

Instantaneous velocity distribution

Fig 4. Effect of Re on film-cooling flows ($R = 0.7$, $Tu = 1\%$)

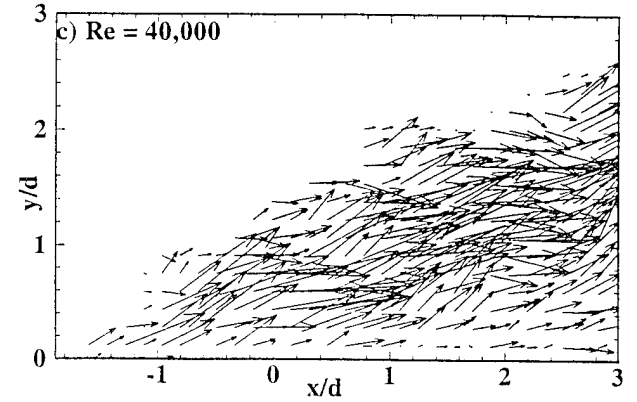
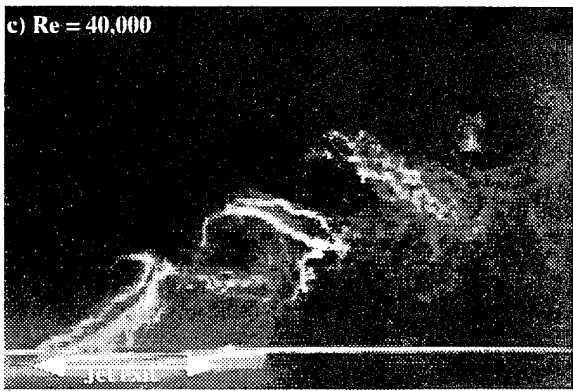
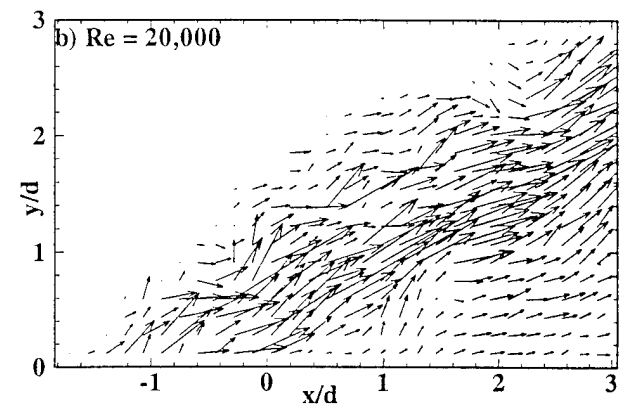
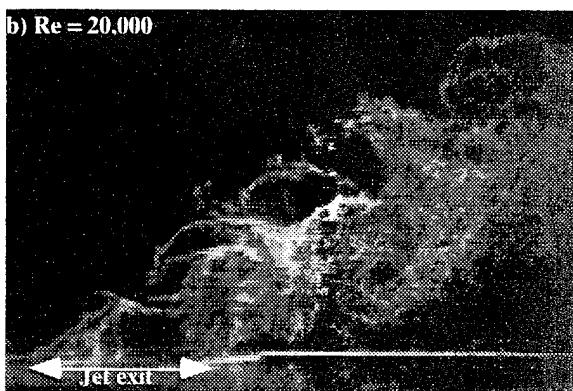
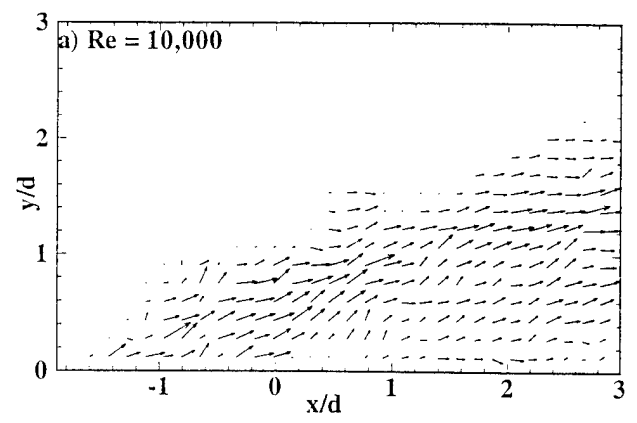
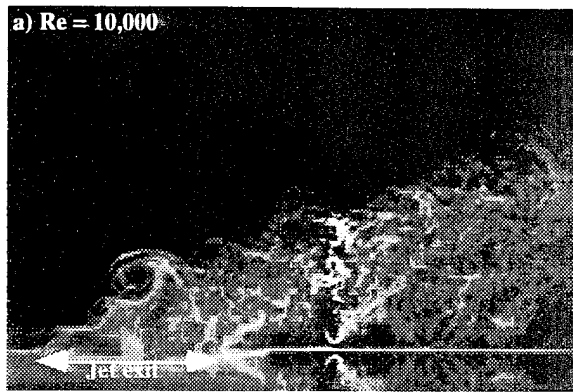

Double exposed PIV images

Instantaneous velocity distribution

Fig 5. Effect of Re on film-cooling flows ($R = 1.5$, $Tu = 17\%$)

Goss, L. P., Trump, D. D. and Frank, J. 1994, Two-Color Particle-Imaging Velocimetry Employing a Single CCD Camera, Combustion Fundamentals and Applications (Proceedings 1994 Technical Meeting, Central States Section, The Combustion Institute), pp. 237-242, The Combustion Institute, Pittsburgh, PA.

Grant, I. and Liu, A. 1990, Directional Ambiguity Resolution in Particle Image Velocimetry by Pulse Tagging, Exp. Fluids, vol. 10, pp. 71-76.

Kline, S. J. and McClintock, F. S. 1953, Describing Uncertainties in Single-Sample Experiments, Mech. Eng., vol. 75, pp. 3-8.

Landreth, C. C. and Adrian, R. J. 1988, Electro-Optical Image Shifting for Particle Image Velocimetry, Appl. Opt. vol. 27, pp. 4216-4220.

Lourenco, L. M. 1993, A Velocity Bias Technique for PIV Measurements of High Speed Flows, Appl. Opt., vol. 32, no. 12, pp. 2159-2162.

Lourenco, L. M., Gogineni, S. P. and LaSalle, R. T. 1994, On-Line Particle Image Velocimeter: An Integrated Approach, Appl. Opt., vol. 33, no. 13, pp. 2465-2470.

Okada, E., Enomoto, H., Fukuoka, Y. and Minamitani, H. 1990, Instantaneous Particle Image Velocimetry with Electronic Specklegram, in Proceedings of Applications of Laser Techniques to Fluid Mechanics, ed. R. J. Adrian, D. F. G. Durao, F. Durst, M. Maeda and J. H. Whitelaw, pp. 464-475, Springer-Verlag, New York.

Willert, C. E. and Gharib, M. 1991, Digital Particle Image Velocimetry, Exp. Fluids, vol. 10, pp. 181-193.