

**KEALAKAHA STREAM BRIDGE REPLACEMENT PROJECT  
SEISMIC INSTRUMENTATION PLAN**

A CE 699 REPORT SUBMITTED TO THE CIVIL ENGINEERING  
DEPARTMENT OF THE UNIVERSITY OF HAWAII AT MANOA IN  
PARTIAL FULFILLMENT OF THE REQUIREMENTS FOR DEGREE OF  
MASTER OF SCIENCE (PLAN B) IN CIVIL ENGINEERING

JULY 1996

By

Todd W. Stephens  
B.S.C.E., Clemson University, 1989

Committee:

Dr. Ian Robertson, Chairman  
Dr. Harold Hamada  
Dr. H. Ronald Riggs

DTIC QUALITY INSPECTED &

19960826 026

**DISTRIBUTION STATEMENT A**

Approved for public release;  
Distribution Unlimited

AD NUMBER	DATE 12 Aug 96	DTIC ACCESSION NOTICE
1. REPORT IDENTIFYING INFORMATION		<b>REQUESTER:</b>  1. P or 2. C  3. A n 4. U ii 5. D fi  <b>DTI</b> 1. A 2. B  <b>19960826 026</b>
<b>A. ORIGINATING AGENCY</b> NAVAL POSTGRADUATE SCHOOL, MONTEREY, CA 93943		
<b>B. REPORT TITLE AND/OR NUMBER</b> A CE 699 Report Submitted to the Civil Engr Dept of The U. of HI at Manoa In Partial		
<b>C. MONITOR REPORT NUMBER</b> University of STEPHENS, Todd W. Thesis Jul 96 Hawaii		
<b>D. PREPARED UNDER CONTRACT NUMBER</b> N00123-89-G-0551		
2. DISTRIBUTION STATEMENT   <p style="text-align: center;"><del>APPROVED FOR PUBLIC RELEASE;</del>  <del>DISTRIBUTION STATEMENT</del></p>		

DTIC Form 50  
DEC 91

PREVIOUS EDITIONS ARE OBSOLETE

# DISCLAIMER NOTICE



**THIS DOCUMENT IS BEST  
QUALITY AVAILABLE. THE  
COPY FURNISHED TO DTIC  
CONTAINED A SIGNIFICANT  
NUMBER OF PAGES WHICH DO  
NOT REPRODUCE LEGIBLY.**

## EXECUTIVE SUMMARY

This report outlines the research undertaken for the development of a seismic instrumentation and monitoring plan, to be proposed to the Hawaii Department of Transportation (HDOT), for the Kealakaha Stream Bridge Replacement Project. The Kealakaha Stream Bridge will replace the old Kealakaha Stream Bridge, located 21 miles north of Hilo, Hawaii, with a new 645 foot structure. Construction is expected to begin in late 1997 (HDOT, 1995).

This study utilizes information contained in several California Strong Motion Instrumentation Program (CSMIP) Data Utilization Reports to analyze and interpret the engineering and theory associated with bridge structure instrumentation and monitoring. In addition, these reports were used to investigate the types of information that can be obtained from acceleration data and what methods were used to process the data.

The proposed seismic instrumentation plan consists of 41 seismic accelerometers, 4 relative displacement sensors and three data recording units. All instruments and recorders are interconnected and have direct download capability to various research centers. The instruments will monitor and record the full motion of the structure, including free-field motion, pile cap translation and rotation, deck and abutment accelerations, joint movement and column bent rotation.

The acceleration data provided by the proposed instrumentation will be used to identify the structure's fundamental and most significant frequencies, calculate deck level acceleration amplification functions, investigate soil-structure interaction effects, and compare the design analytical model with the recorded motion of the structure.

# Table of Contents

Executive Summary .....	i
List of Tables .....	v
List of Figures .....	vi
Chapter 1: Introduction.....	1
Chapter 2: Project Objectives .....	3
Chapter 3: Overview of Hawaii's Seismic Activity .....	4
3.1 Past Earthquakes on the Island of Hawaii.....	4
3.2 Peak Ground Acceleration and Zoning Maps .....	4
3.3 Hawaii State Civil Defense Action .....	5
3.4 Seismic Instrumentation.....	6
Chapter 4: California Strong Motion Instrumentation Program.....	7
4.1 California Strong Motion Instrumentation Plan .....	7
4.2 CSMIP Report Review .....	8
4.3 Report Acknowledgments.....	8
Chapter 5: CSMIP I-10/215 Interchange Bridge Report Summary.....	9
5.1 CSMIP Report Objectives.....	9
5.2 Bridge Description.....	9
5.3 Seismic Instrumentation.....	10
5.4 Analysis Methods.....	11
5.4.1 Spectral Analysis .....	11
5.4.2 Parametric Analysis .....	12
5.4.3 Analytical Model Comparison.....	12
5.5 Report Conclusions and Recommendations .....	12
Chapter 6: CSMIP Hayward Bart Elevated Section Report Summary.....	14
6.1 CSMIP Report Objectives.....	14
6.2 Bridge Description .....	14
6.3 Seismic Instrumentation.....	14

6.4	Analysis Methods.....	15
6.5	Report Conclusions and Recommendations .....	16
Chapter 7: CSMIP Hwy 101/Painter Street Overpass Report Summary.....		18
7.1	CSMIP Report Objectives.....	18
7.2	Bridge Description.....	18
7.3	Seismic Instrumentation.....	19
7.4	Analysis Methods.....	19
7.4.1	Structural Idealization.....	19
7.4.2	Equilibrium Equations .....	20
7.4.3	Abutment Forces and Deformations .....	20
7.4.4	Abutment Stiffness .....	20
7.5	Report Conclusions and Recommendations .....	21
Chapter 8: Kealakaha Stream Bridge Description.....		22
8.1	Project Location .....	22
8.2	Proposed Construction.....	22
8.3	Project Schedule and Construction Costs .....	22
Chapter 9: Instrumentation Plan .....		24
9.1	Introduction.....	24
9.2	Free-Field Acceleration.....	24
9.3	Support and Abutment Acceleration.....	25
9.4	Soil-Structure Interaction.....	26
9.5	Support Rotation .....	27
9.6	Transverse and Longitudinal Deck Level Acceleration.....	27
9.7	Joint Monitoring .....	28
9.8	Bent Support Rotation .....	29
9.9	Vertical Mid-Span Acceleration .....	30
9.10	Non-Uniform Support Motion.....	30
Chapter 10: Strong Motion Instrument and Recorder Information .....		31
10.1	Force Balance Accelerometers.....	31
10.2	Acceleration Recorders.....	31

10.3 Relative Displacement Sensors.....	32
10.4 Possible Vendors.....	33
Chapter 11: Construction and Design Issues .....	34
11.1 As-Built Material Properties .....	34
11.2 Support Accelerometers.....	34
11.3 Other Considerations .....	35
Chapter 12: Summary and Conclusion .....	36
12.2 CSMIP Recommended Changes.....	36
12.1 Questions to be Answered .....	37
12.3 Conclusion .....	38
References.....	39
Tables.....	40
Figures.....	45

## LIST OF TABLES

Table	Page
1. Location of Strong Motion Accelerometers on Northwest Connector and Maximum Response in Landers and Big Bear Earthquakes (From: Fenves, 1995).....	40
2. Kealakaha Bridge Proposed Seismic Instrumentation Locations, Description and Objectives .....	42

## LIST OF FIGURES

Figures	Page
1. Historical Island of Hawaii Earthquakes with Magnitude Greater than 6.0 (From: Clague, 1995).....	45
2. Current Seismic Zonation for the Hawaiian Islands (From: UBC, 1994) .....	46
3. Peak Ground Acceleration (in g) for a 50 Year Exposure Time with a 90% Probability of Not Being Exceeded (From: Klein, 1995).....	47
4. Effective Peak Ground Acceleration (in g) for a 50 Year Exposure Time with a 90% Probability of Not Being Exceeded (From: Klein, 1995) .....	48
5. Comparison of Peak Ground Acceleration (PGA) and Effective Peak Ground Acceleration (EPA) for Three Hawaiian Earthquakes (From: Klein, 1995) .....	49
6. Proposed Seismic Zonation for the Hawaiian Islands (From: Klein, 1995) .....	50
7. Schematic Plan of the Interstate 10/215 Interchange in Colton, California (From: Fenves, 1995).....	51
8. General Plan of Northwest Connector (From: Fenves, 1995) .....	52
9. Single Column Bent and Box Girder Cross-Section. Original and Retrofit Design (From: Fenves, 1995).....	53
10. Seismic Instrumentation for the Northwest Connector (From: Fenves, 1995)..	54
11. Location of the CSMIP- Instrumented BART Elevated Structure Relative to Hayward BART Station (From: Tseng, 1992).....	55
12. Structural Configuration and Dimensions of the CSMIP- Instrumented Section (From: Tseng, 1992) .....	56
13. Instrument Locations on the Hayward-BART Elevated Section (From: Tseng, 1992) .....	57
14. US 101/Painter Street Overpass: Structural Details and Instrument Locations (Goel, 1995) .....	58

15. Free-Body Diagram for Structural Idealization of US 101/Painter Street Overpass (Goel, 1995).....	59
16. Kealakaha Stream Bridge Replacement Project Site Map/Location (From: HDOT, 1995).....	60
17. Proposed Kealakaha Stream Bridge Alignment (From: HDOT, 1995).....	61
18. Existing and Proposed Kealakaha Stream Bridge Alignment (From: HDOT, 1995).....	62
19. Longitudinal Section of New Proposed Kealakaha Stream Bridge (From: HDOT, 1995).....	63
20. Kealakaha Bridge Seismic Instrument Locations (Elevation View) .....	64
21. Kealakaha Bridge Seismic Instrument Locations (Plan View).....	65
22. Kealakaha Bridge Support Seismic Instrument Locations (Plan View).....	66
23. Kealakaha Bridge Relative Displacement Sensor (RDS) Locations .....	67
24. Kinometrics Force Balance Accelerometers .....	68
25. Terra Technology Corp. Accelerometers .....	69
26. Kinometrics Multi-Channel Central Recording System .....	70
27. Terra Technology Corp. Central Recorder .....	71

## CHAPTER 1

### INTRODUCTION

Currently the California Department of Transportation (Caltrans) is heavily monitoring seismic events and their effects on bridge structures. Large scale retrofiting of existing bridge structures began after the 1971 San Fernando earthquake which resulted in major damage and collapse of several Caltrans freeway bridge structures. Designers and researchers are working hard at improving the safety of all structures; extensive acceleration data is a critical part of this process.

The island of Hawaii has proven itself to be a significant seismic hazard, having experienced earthquakes with magnitude 7.2 as recently as 1975. The potential for significant damage from seismic events is high, making the monitoring of seismic events critical in order to continually improve earthquake resistant designs.

Currently, there are no instrumented bridge structures or structural seismic monitoring programs in Hawaii. However, the Hawaii Department of Transportation has initiated a project to replace the Kealakaha Stream Bridge near Hilo. This project provides an opportunity to implement seismic monitoring in the State of Hawaii.

The State of California has initiated a Strong Motion Instrumentation Program (SMIP), which is a specialized long-range project to collect and evaluate data on the response of structures and foundation materials to strong ground shaking. The program maintains strong motion recorders in representative structures and geologic environments throughout the state. Data collected is used by the structural community for developing earthquake-resistant structures.

This report discusses the findings of the CSMIP studies and reviews the recommended changes suggested for future instrumentation projects and includes a proposed seismic instrumentation plan for the Kealakaha Stream Bridge Replacement Project.

## CHAPTER 2

### PROJECT OBJECTIVES

The overall project goal was to develop a seismic instrumentation plan for the Kealakaha Stream Bridge Replacement Project. To accomplish this goal, the following steps were taken:

- Reviewed three California Strong Motion Instrumentation Program (CSMIP) Data Utilization Reports which specifically addressed seismic bridge instrumentation. The three reports were:
  - \* Interchange Bridge Near San Bernardino (CSMIP/95-02)
  - \* Hwy. 101/Painter Street Overpass Near Eureka (CSMIP/95-01)
  - \* Hayward Bart Elevated Section (CSMIP/92-02)
- Interpreted the engineering and theory associated with the three seismic instrumentation plans developed for the structures listed above, specifically focusing on instrument location, total number of accelerometers and results desired from the recorded acceleration data.
- Briefly summarized how the three reports utilized acceleration data to analyze the structure and its response to strong ground shaking.
- Incorporated the reports' recommended changes for improved seismic instrumentation into the development of an instrumentation plan for the Kealakaha Stream Bridge Replacement Project.
- Presented the desired objectives of the proposed Kealakaha Stream Bridge Replacement Project seismic instrumentation plan.
- Developed the seismic instrumentation plan for the Kealakaha Stream Bridge Replacement Project.

CHAPTER 3  
OVERVIEW OF HAWAII'S SEISMIC ACTIVITY

3.1 Past Earthquakes on the Island of Hawaii

One of the most important natural hazards in Hawaii is strong ground shaking produced by large earthquakes. As shown in Figure 1, the island of Hawaii has experienced many earthquakes with magnitudes greater than 6.0 on the Richter Scale. Though most earthquakes have occurred in the southern and central region, a magnitude 6.2 earthquake with an epicenter north of Hilo occurred as recently as 1973. The largest earthquake recorded in Hawaii occurred in 1868 with an estimated magnitude of 8.0. The next largest had a magnitude of 7.2 and occurred in 1975. Earthquake recurrence intervals for the island of Hawaii are estimated as follows (Clague, 1995):

Magnitude (Richter Scale)	Recurrence Interval (years)
≥5.5	3.3-5
≥7.0	29-44
= 8.0	120-190.

3.2 Peak Ground Acceleration and Zoning Maps

Anticipated Peak Ground Acceleration (PGA) is expressed in terms of probabilities estimated from observations of past earthquakes and strong ground shaking. Hazard levels are generally expressed as the PGA level with a 10% chance of being exceeded (or 90% chance of not being exceeded) in an exposure time of 50 years. This is equivalent to a PGA which has a 475-year return period. *Effective Peak Ground Accelerations* (EPA) is derived from the average 5% damped response spectral value between 0.1 and 0.5 second periods (Klein, 1995).

In 1994, the zonation criteria, as established by the Uniform Building Code, defines seismic zone 4 as an area which has a 475-year return period EPA of greater than 0.3g. As shown in Figure 2, the island of Hawaii is currently located in seismic zone 3. Figure 3 shows a contour map of the estimated peak ground acceleration (PGA) for Hawaii. Figure 4 shows the effective peak ground acceleration (EPA) for the island of Hawaii. The EPA values for this plot were calculated using the formula,  $EPA = 0.85 * PGA$  (the 0.85 came from an 'eyeball' fit of EPA values vs. PGA values less than 0.5g, ignoring the data points corresponding to volcanic ash sites, see Figure 5). It is important to note that the EPA coefficient of 0.85 was calculated based on rock sites only. It has been shown that thick volcanic ash cover (more than 0.5m) amplifies ground shaking as much as two times compared to rock sites. Virtually all of the island of Hawaii has an EPA greater than 0.3g (Klein 1995).

### 3.3 Hawaii State Civil Defense Action

In 1996, the State of Hawaii, Department of Defense, Civil Defense Division, on the advise of the Hawaii State Earthquake Advisory Board (HSEAB), recommended to the International Conference of Building Officials a code change to seismic zone 4 for the island of Hawaii, (see Figure 6). Their recommendation was based on the Klein (1995) and Clague (1995) reports, which illustrate that the island of Hawaii has a 475-year return period effective peak ground acceleration greater than 0.3g, see Figure 4. The referenced reports, and the action by the Hawaii State Civil Defense, indicates that the island of Hawaii is an area which experiences significant earthquake activity with a relatively short recurrence interval. It is therefore an ideal location for the evaluation of structural response to strong ground shaking. Such studies will provide valuable information regarding the performance of structures on the island of Hawaii, and will enhance ongoing research in the area of earthquake engineering.

### 3.4 Seismic Instrumentation

The short recurrence periods for significant earthquake activity on the island of Hawaii provides an ideal opportunity for evaluation of structural response using seismic instrumentation. Areas of the mainland United States with similar earthquake activity, such as California and Washington State, are actively instrumenting both building and bridge structures to monitor their performance during future earthquakes.

The Kealakaha Stream Bridge Replacement Project provides an excellent opportunity for the first seismic instrumentation of a major bridge structure in Hawaii. Experience gained from the Kealakaha structure instrumentation will provide valuable information about the seismic performance of this and other bridge structures in Hawaii, and will aid greatly in the preparation of future instrumentation projects in Hawaii.

## CHAPTER 4

### CALIFORNIA STRONG MOTION INSTRUMENTATION PROGRAM

#### 4.1 California Strong Motion Instrumentation Program

The California Strong Motion Instrumentation Program (CSMIP) which works under the Department of Conservation, Division of Mines and Geology, is currently working with the California Department of Transportation (Caltrans) Division of Structures, to instrument numerous bridge structures, both old and new, in order to gain information and data regarding response to strong ground shaking. This valuable information will begin to bridge the gap between predicted analytical response and actual structural response. Subsequent to each significant earthquake, Data Utilization Reports are prepared by CSMIP staff and other researchers. The objectives of the CSMIP Data Utilization Reports, as stated by Goel and Chopra (1995), are as follows:

- Understand the spatial variation and magnitude dependence of earthquake strong ground motion.
- Understand the effects of earthquake motions on the response of geologic formations, buildings and lifeline structures.
- Expedite the incorporation of knowledge of earthquake shaking into revisions of seismic codes and practices.
- Increase awareness within the seismological and earthquake engineering community about the effective usage of strong motion data.
- Improve instrument methods and data processing techniques to maximize the usefulness of SMIP data. Develop data representations to increase the usefulness and the applicability to design engineers.

## 4.2 CSMIP Report Review

Because of the CSMIP's efforts and expertise in the area of seismic bridge instrumentation, three reports sponsored by CSMIP were used to analyze and interpret the engineering and theory associated with such bridge instrumentation and monitoring. In addition, the studies were used to investigate what information can be obtained from acceleration data and what methods are used to process the data. This information will be incorporated into the Kealakaha Stream Bridge Replacement Project seismic instrumentation plan.

## 4.3 Report Acknowledgments

The three CSMIP reports reviewed were:

1. Fenves, G. L. and Desroches, R. (1995, March), CSMIP/95-02 Data Utilization Report, Evaluation of the Response of I-10/215 Interchange Bridge Near San Bernardino in the 1992 Landers and Big Bear Earthquakes, Office of Strong Motion Studies, Sacramento, CA
2. Tseng, W. S., Yang, M. S. and Penzien J. (1992, September), CSMIP/92-02 Data Utilization Report, Seismic Performance Investigation of the Hayward Bart Elevated Section, , Office of Strong Motion Studies, Sacramento, CA
3. Goel, R. K. and Chopra, A. K. (1995, March), CSMIP/95-01 Data Utilization Report, Seismic Response Study of the HWY 101/Painter Street Overpass Near Eureka Using Strong-Motion Records, Office of Strong Motion Studies, Sacramento, CA

The following three chapters summarize the objectives, instrumentation, analysis methods and conclusions of each of these reports.

## CHAPTER 5

### I-10/215 INTERCHANGE BRIDGE NEAR SAN BERNARDINO

#### 5.1 CSMIP Report Objectives

The specific objectives of this report were as follows (Fenves, 1995):

- Evaluate the importance of non-uniform support motion on the response of the bridge.
- Determine the vibration properties of the bridge.
- Determine the effectiveness of typical modeling and dynamic analysis techniques used in the design of bridges to predict the response recorded in the studied earthquakes.
- Examine the role of the intermediate hinges on the earthquake response of the bridge.

#### 5.2 Bridge Description

The I-10/215 Northwest Connector is a 2540 ft long, curved concrete box girder bridge with sixteen spans supported by single column bents and diaphragm abutments (Figures 7 and 8). Constructed in 1973, the bridge was retrofitted for improved earthquake performance in 1991. The main modification to the bridge provided steel jackets around the columns (Figure 9). The goal of the modification was to provide increased confinement, shear strength and flexural ductility. It was not intended to increase the stiffness of the columns. The northern half of the Connector is located in the San Jacinto fault zone. There is a free-field ground motion station located 825 feet from the Connector (Figure 7). The Connector is instrumented with 34 accelerometers located as shown in Figure 10. The Connector's structural system consists of six frames, connected at five intermediate hinges (Figure 10). The hinges are designated by the spans in which they are located: Hinge 3, Hinge 7, Hinge 9,

Hinge 11, Hinge 13. The frames have a cast in-place box girder superstructure supported by two to four single column bents. The box girders in two frames (Hinge 3 to Hinge 7 and Hinge 9 to Hinge 11) are post-tensioned in the longitudinal direction. The spans of the four conventionally reinforced frames range from 75 ft to 155 ft. The spans of the post-tensioned frames range from 183 ft to 204 ft. The column height (from top of pile cap to the box girder soffit) varies from 24 ft for Bent 16 to 77 ft for Bent 5.

### 5.3 Seismic Instrumentation

The Connector has been extensively instrumented with a network of strong motion accelerometers. Figure 10 and Table 1 show the location and directions of the thirty-four accelerometers on the Connector. A sheltered ground motion station is located approximately 825 ft east of Bent 11. The ground motion station is approximately 1400 ft from Bent 8 which is the most heavily instrumented portion of the structure (Fenves, 1995).

The thirty-four force balance accelerometers on the Connector are connected to nine digital recorders. The recorders have pre-event memory and are interconnected for time synchronization. The free-field ground station was not time synchronized with the Connector recorders which resulted in the need for calculation of a relative start time between the free-field recorders and Connector recorders. The Office of Strong Motion Studies processed the recorded acceleration data for instrument baseline-corrections, including integration to obtain the velocity and displacement records. The acceleration readings were sampled at 100 Hz ( $\Delta t = 0.01$  sec). As a result of filtering, the usable bandwidth for the data was 0.17 Hz to 47.2 Hz which corresponds to periods between 5.9 sec and 0.021 sec (Fenves, 1995).

Table 1 lists the location of the instruments, direction (longitudinal, transverse, or vertical) and the maximum acceleration and displacement in the two earthquakes studied from the processed records.

## 5.4 Analysis Methods

### 5.4.1 Spectral Analysis

Using spectral analysis, transmissibility functions were derived which produce a ratio of ground acceleration (input) to the structure acceleration (output). Transmissibility functions were computed using an input acceleration in one direction relative to the output acceleration at various locations on the structure. The two input motions that were used were the support acceleration at mid-span (Bent 8) and the free-field ground acceleration. Output motions were the recorded accelerations at various locations on the structure (Fenves, 1995).

For each input-output pair, three quantities were plotted as a function of frequency:

- Absolute value of the transmissibility function
- The phase angle, in degrees, of the transmissibility function
- The coherence function for the transmissibility estimate

The transmissibility functions obtained from spectral analysis identify the frequencies of excitation with high amplification. These were the resonant frequencies of the structure, each of which corresponded to a vibration mode. The study noted possible errors in this type of analysis, therefore a warning was given that the results should only be viewed as qualitative results (Fenves, 1995).

#### 5.4.2 Parametric Analysis

A second method to evaluate vibration properties of the structures utilized parametric identification. This technique identified vibration properties based on representing structural response in the discrete time domain in terms of parameters of the model. The parameters were estimated by least-squares procedures to minimize the error between the discrete time model and recorded response. In the I10/215 study, a single input, single output model was used for determining vibration frequencies and damping ratios for the Connector. The parametric model involves auto-regression of the input and output histories (Fenves, 1995).

#### 5.4.3 Analytical Model Comparison

The final method of analysis created and compared analytical model response to the actual recorded response of the structure. The approach applied modeling and dynamic analysis procedures typically used for bridge design. The comparison of the predicted to actual response assessed the effectiveness of the analysis methods (Fenves, 1995).

#### 5.5 Report Conclusions and Recommendations (Fenves, 1995)

- The displacement histories for the free-field motion and input motion at four supports were very similar. It was concluded that spatial variation of the input motion is not significant within the range of important vibration frequencies for the Connector.
- Pile cap rotation was not negligible. It produced additional displacements in some columns which accounted for 16 percent of the total column displacement.

- The strong motion records showed the effect of pounding as evidenced by large acceleration spikes for instruments near the five intermediate hinges.
- Shear keys which restrained the transverse and vertical motion of the hinges seemed to 'loosen up' because of earlier seismic events.
- Spectral analysis and parametric identification techniques showed a lengthening of the fundamental period from 1.56 sec to 1.75 sec in two consecutive seismic events, which corresponds to a 25% reduction in stiffness. It was theorized that the reduction in stiffness was a result of the soil and pile foundation loosening during the first event. Crushing of the joint filler material was also a factor.
- There is a need for more free-field instruments for the study of non-uniform support motion. In addition, the report stressed the importance of coordinating the timing between all instruments, free-field and structure.
- It was not possible to determine permanent offset displacements from the recorded strong motion acceleration records. The report suggested the use of rugged displacement measuring devices for hinge displacements.
- The report identified the need for more accurate information concerning concrete properties and a more thorough investigation of the foundation soil profiles and properties.

## CHAPTER 6

### HAYWARD BART ELEVATED SECTION

#### 6.1 CSMIP Report Objectives

The objective of this report was to correlate the CSMIP recorded motions of the Hayward BART (Bay Area Rapid Transit) aerial structure produced by the Loma Prieta earthquake with predicted motions generated through mathematical modeling and analysis. This would allow improvements to be made in the current assessment and performance of such structures under seismic conditions (Tseng, 1992).

#### 6.2 Bridge Description

The structure investigated in this report was a three-span nearly straight section of the BART elevated system located immediately north of the Hayward BART station (Figures 11 and 12). The structure consists of three simply supported twin box girders constructed of prestressed concrete, which are supported on four single-column piers. The footings are supported by reinforced concrete piles. The report notes that the BART train rails are continuous across the joints in the structure and were found to contribute significantly to the motion in the longitudinal direction due to their high axial stiffness (Tseng, 1992).

#### 6.3 Seismic Instrumentation

The CSMIP instrumentation of the structure under investigation consisted of 18 strong-motion acceleration sensors installed both on the structure and in the free-field (Figure 13). These sensors were designated Channels No. 1 through 8 and 10 through 19 (Channel 9 was not installed). The locations and directions of the sensors are shown in Figure 13. As indicated in the figure, triaxial sets and individual sensors were installed at the following locations: (1) one free-field set (No. 17, 18, 19) in a the parking lot about

450 feet west and 640 feet south of the instrumented structure, (2) one set (No. 1, 2, 13) at the base of pier P132, (3) one set (No. 14, 15, 16) at the base of pier P135, (4) four individual sensors (No. 5, 6, 7, 8) at the undersides of the girder decks for measuring the longitudinal motions of the girders, (5) two individual sensors (No. 10 and 11) to measure transverse motion on the girder spanning between piers P132 and P133, (6) two individual sensors (No. 3 and 12) at the center of the pier beam of P132 to measure the longitudinal and transverse motion, respectively, and (7) one individual sensor (No. 4) at the east edge of the pier beam of P132 to measure longitudinal motion (Tseng, 1992).

#### 6.4 Analysis Methods

Acceleration response spectra for 2% damping ratio were computed from the recorded acceleration time-history data. These computed spectra served to identify frequency ranges producing significant structural response amplifications and they served as a comparison for the analytical models computed spectra (Tseng, 1992).

Transfer functions between the structural response motions and the free-field motion were computed. These transfer functions reflect the dynamic response characteristics of the complete structure/foundation system under excitation of the free-field input motion. Significant system frequencies and associated damping values were then determined from these transfer functions (Tseng, 1992).

Recorded acceleration time-histories were doubly integrated to give displacement time-histories from which relative displacement across a joint or girder support were obtained (Tseng, 1992).

During the modeling process, the longitudinal and transverse structural responses observed from the recorded data showed essentially decoupled behaviors; thus, separate longitudinal and transverse models were used to capture overall behavior. Only one span

was modeled because it was observed that all three spans had essentially the same response. Because of the observed soil-structure interaction effects, the dynamic impedance characteristics of the pier foundation system were included in developing the analytical models (Tseng, 1992).

#### 6.5 Report Conclusions and Recommendations (Tseng, 1992)

- The instruments provided valuable information for understanding the seismic response of the structure.
- Longitudinal response differed greatly from the transverse response due to the high axial stiffness of the continuous rails.
- Both longitudinal and transverse responses were significantly influenced by soil-structure interaction effects.
- The maximum seismically induced column base moments were approximately 45% of the column's ultimate moment capacity. When a linear analytical model of the structure was subjected to the Maximum Credible Earthquake (MCE) PGA level of 0.7g, the maximum load induced seismic base moment, predicted by the linear models, was found to exceed the design moment capacity by a factor of 4. This is less than the ductility capacity estimated to be in the range of 6 to 8, so the structure would be expected to survive such an earthquake without collapse.
- Soil-structure interaction effects were shown to be important. This would require more instruments to be placed at the foundation level to produce sufficient data for evaluating separate modes of foundation response. The current CSMIP instrumentation on this structure was not sufficient for such evaluation.
- The report identified a need for instrumentation that allows independent recording of the rocking rotation responses at the bases of pier columns for more accurate calculation of column deformations.

- Free-field recorders should be located closer to the structure.
- Accurate determination of elastomeric pad properties and the effect of the time and weather on these properties, is necessary for analytical modeling of the structure.

## CHAPTER 7

### HWY 101/PAINTER STREET OVERPASS NEAR EUREKA

#### 7.1 CSMIP Report Objectives

The objectives of the Hwy. 101/Painter Street Overpass report were to (Goel, 1995):

- Develop a procedure to estimate the stiffness of abutment-soil systems directly from earthquake motion using a simple equilibrium-based approach without finite-element modeling of the structure or the abutment-soil system.
- Calculate abutment stiffness, which includes the effects of soil-structure interaction and non-linear behavior of the soil.
- From abutment stiffness calculations, investigate effects of abutment deformation on abutment stiffness during an earthquake.
- Evaluate and compare calculated abutment stiffness with that of the stiffness calculated from CALTRANS (1989), AASHTO-83 (1988) and ATC-6 (1981) procedures.

#### 7.2 Bridge Description

The US 101/Painter Street Overpass, shown in Figure 14, is located in Rio Dell, California. This 265 ft long bridge consists of a continuous reinforced-concrete multi-cell box-girder road deck supported on integral abutments at the two ends and on a reinforced-concrete two-column bent. The bent divides the bridge into two unequal spans of 119 ft and 146 ft. Both abutments and bent are skewed at an angle of 38.9 degrees. The east abutment is monolithic with the superstructure and is supported on 14 driven 45-ton concrete friction piles. The west abutment rests on a neoprene bearing strip that is

part of a designed thermal expansion joint of the road deck. The foundation of this abutment consists of 16 driven 45-ton concrete friction piles (Goel, 1995).

### 7.3 Seismic Instrumentation

The Hwy. 101/Painter Street Overpass was instrumented by the CSMIP in 1977. Figure 14 shows the location of the accelerometers. The instrumentation consists of a free-field set of triaxial accelerometers located about 320 feet north of the east abutment recording three components of the free-field motion (channels 12, 13, and 14). Triaxial accelerometers also record the three components of the abutment motion adjacent to the road deck: channels 15, 16 and 17 at the east end, and channels 18, 19 and 20 at the west end. The instrumentation on the structure consists of three uniaxial accelerometers recording three components of motion at the base of the north column in the two column bent (channels 1, 2, 3); two uniaxial accelerometers recording transverse motion of the deck near the west abutment (channel 4) and near the north column face (channel 7); three uniaxial accelerometers recording the vertical motion of the deck near the west abutment (channel 5), approximately mid-way between the west abutment and the central bent (channel 6), and approximately mid-way between the central bent and the east abutment (channel 8); and a set of triaxial accelerometers recording three components of the deck motion near the east abutment (channels 9, 10, and 11). The data from these channels was recorded by two time synchronized recorders housed in a shelter located near the east abutment (Goel, 1995).

### 7.4 Analysis Methods

#### 7.4.1 Structural Idealization

The structure was idealized into a model which consisted of a road deck and three spring-damper systems, which represented the stiffness and damping properties of the

abutment-soil systems along the east abutment, normal to the east abutment and along the west abutment (Figure 15). Each column in the central bent was represented by two linear elastic springs, one normal to and the other along the bent. These column spring stiffness were assumed know and elastic analysis was used since no cracking was observed (Goel, 1995).

#### 7.4.2 Equilibrium Equations

Figure 15 shows a free body diagram of the structural idealization. The three equations of dynamic equilibrium for this system in the  $x$ ,  $y$ ,  $\theta$  direction were:

$$f_i + f_D + f_S = 0 \quad (1)$$

Inertial ( $f_i$ ), damping ( $f_D$ ) and spring forces ( $f_S$ ) were calculated by transforming abutment and column forces into the  $x$ ,  $y$ ,  $\theta$  coordinate system (Goel, 1995).

#### 7.4.3 Abutment Forces and Deformations

The only unknowns in equation (1) were the abutment forces, which were determined by solving the three equations at specific time intervals. Inertial forces came from mass properties and recorded acceleration data. Column forces were determined from known stiffness and deformation. Deformation of the spring-damper system modeling the abutment was determined by subtracting the free-field motion from the motion at the top of the abutment (Goel, 1995).

#### 7.4.4 Abutment Stiffness

Solution of the three algebraic equations (1) at each time instant lead to the abutment forces which were then plotted against the computed displacements. The

stiffness of the abutment-soil system was determined by isolating loops from the force deformation plots and calculating the slope of the major axis of the ellipse (Goel, 1995).

#### 7.5 Report Conclusions and Recommendations (Goel, 1995)

- The abutment stiffness was significantly different during different phases of the shaking and decreases significantly as the abutment deformation increases. This highlighted the non-linear behavior of the soil.
- The CALTRANS procedure for short bridge abutment stiffness calculations leads to a good estimate in the transverse direction provided the deformation assumed in computing the stiffness is close to the actual deformation during the earthquakes. CALTRANS overestimates in the longitudinal direction. The AASHTO-83 and ATC-6 procedures both gave initial estimates of abutment stiffness in both the transverse and longitudinal directions higher than the stiffness values during the earthquake.
- The report identified a need for additional free-field or input motion at various locations such as abutments and column bents to more accurately represent the actual motion of the structure.

## CHAPTER 8

### KEALAKAHA STREAM BRIDGE REPLACEMENT PROJECT DESCRIPTION

#### 8.1 Project Location

The Kealakaha Stream Bridge Replacement Project is located on Hawaii Belt Road (Route 19) near the town of Kukaiiau in the Hamakua District on the Island of Hawaii. It is situated approximately ten miles east of Honokaa , 26 miles northwest of Hilo and one mile from the coast, (see Figure 16). The Hawaii Belt Road provides the primary transportation link between Hilo and Kailua-Kona (Hawaii DOT, 1995).

#### 8.2 Proposed Construction

The State of Hawaii Department of Transportation proposes to construct a new bridge over Kealakaha Stream as part of the Hawaii Belt Road. The proposed bridge will be located adjacent to the existing bridge. It will be 645 feet long and will consist of two 12-foot lanes with 12-foot shoulders on both sides. Three piers ranging in height from 60 to 130 feet and four spans of 140 to 180 feet each are proposed. The centerline of the proposed bridge alignment will be approximately 120 feet downstream of the existing bridge structure (1,800-foot radius). Figure 17 shows the existing and proposed bridge alignments. Figures 18 and 19 show a plan and elevation of the proposed structure (Hawaii DOT, 1995).

#### 8.3 Project Schedule and Construction Costs

Construction will proceed in phases and is estimated to begin in 1997. The estimated cost of construction is \$14.5 million, with funding provided by the State Department of Transportation and FHWA.

For any federally-funded highway project over \$10 million, federal law requires two separate designs. For the proposed project, both designs essentially follow the same alignment, the main difference being the method of construction. The preferred design utilizes a pre-cast girder system, while the alternative design consists of segmental post-tensioned construction. The instrumentation plan developed as part of this report is based on the precast girder design. Modifications of this proposed instrumentation plan may be required if an alternate design is used (Hawaii DOT, 1995).

## CHAPTER 9

### INSTRUMENTATION PLAN

#### 9.1 Introduction

The instrumentation plan developed for the Kealakaha Stream Bridge Replacement Project was developed by first, establishing what information is desired from the recorded acceleration data, and second, by understanding the methods and procedures that will be used to analyze the recorded data. The CSMIP Data Utilization Reports (summarized in Chapters 5 through 7) provided the necessary information to decide what recorded acceleration data is desired and how it will be processed.

This chapter will discuss the need for recording free-field motion, support acceleration, soil-structure interaction, support and column bent rotation, deck level and abutment acceleration, and joint displacement measurement. Each of these have been incorporated into the formulation of the Kealakaha Bridge seismic instrumentation plan.

Table 2 lists all the instruments and associated channels proposed for the project. Figures 20 through 23 show instrument locations on the structure and supports. The orientation of the free-field instruments will be along and orthogonal to the chord connecting the east and west abutments. The structure instruments will be oriented along the tangential and radial directions on the curved bridge. Because the design is preliminary and subject to change, exact and detailed location and selection of specific instrument and recording devices is not discussed.

#### 9.2 Free-Field Acceleration

Free-field acceleration data is necessary as a baseline for earthquake strong ground shaking input to the structure. It is also required for comparison to the support

acceleration in order to study the effects of soil-structure interaction. Free-field accelerometers should be placed more than 50 feet, but less than 200 feet, from the structure. Free-field acceleration data obtained closer than 50 feet from the structure may be influenced by the presence of the structure. Accelerometers located further than 200 feet from the bridge may not experience the same ground shaking as the structure. In addition, the soil properties and profiles may be different from those where the structure is located. If only one set of free-field accelerometers is to be used, placement should be made on soil that mirrors the soil properties and profiles on which the structure rests. If two free-field recorder sets are installed, the second should be placed on a rock outcrop to evaluate the soil effect on the ground shaking. Programs such as SHAKE (Schnabel, 1972) could be used to compare analytical calculations of soil effects with actual recorded motion.

Channels (1, 2, 3) will record the free-field motion on the south side of the structure, approximately 75 feet south of pier 2, (see Figure 21). The recommendation of the CSMIP to record two sets of free-field acceleration data was not followed because the overall structure length was determined to be too short to obtain any significant results of non-uniform support analysis. Also, the number of recording channels is limited and other instrument locations were deemed more important.

### 9.3 Support and Abutment Acceleration

Recording foundation and abutment acceleration is important because these recorded accelerations are the input accelerations experienced by the structure. The recorded acceleration data will be used for comparison with free-field motion and for investigation of soil-structure interaction effects. It will also be used as input for analytical modeling of the bridge structure. All three principle directions (vertical, longitudinal and transverse) will be recorded at both abutments and all column supports. Extensive instrumentation of the abutments and the supports is important in order to

isolate the structure from the soil when performing either parametric or analytical model analysis. Isolation provides the opportunity for a two step analysis method; first looking at the structure and then at the soil-structure interaction.

#### 9.4 Soil-Structure Interaction

Soil-structure interaction effects were shown to be important in the Hayward BART report. In addition, the primary goal of the Hwy 101/Painter Street report was to estimate abutment stiffnesses for use in the analytical models. Having the ability to study and possibly quantify these effects will be of great value to designers and will significantly improve the accuracy of analytical models and their prediction of structural response.

In order for soil-structure interaction effects to be studied completely, a thorough geotechnical investigation must be performed to obtain all necessary soil properties such as Young's modulus, shear modulus, damping ratio and effective spring constants. Having accurate soil properties, coupled with the recorded strong motion records of both the bridge supports and free-field, will lead to improved understanding of soil-structure interaction.

Channels (1, 2, 3) will record the free-field ground motion. Support motion will be recorded at piers 1, 2, and 3 by channels (8, 9, 10), (12, 13, 14), and (17, 18, 19) respectively. Channels (4, 5, 6) and (26, 27, 28) will record the acceleration at the west and east abutments respectively.

## 9.5 Support Rotation

Support rotation is a significant factor when calculating seismically induced moments from column deformation. In the I-10/215 report, support rotation accounted for up to 16% of the overall column displacement in one location. In the Hayward BART report, further refinement of the foundation model was not possible because it was impossible to separate the rocking component and translation component from the pier base motion. The report commented that this information would be most desirable.

The support rotation is measured by calculating the difference between two vertical displacements (processed from the recorded vertical acceleration) divided by the distance between the two recorders. It would be ideal to measure all rotations at all supports, but cost will usually not allow such extensive measurement.

In the Kealakaha Bridge, pier 2, which is the tallest column, will be used to measure the support rotation about the longitudinal and transverse axes. Channels (11, 12, 15) will provide the necessary acceleration data.

## 9.6 Transverse and Longitudinal Deck Level Acceleration

Deck level acceleration measurements provide the data to compute the vibration properties of the structure. These calculations are achieved by evaluating the amplification between input acceleration at the supports and acceleration at various locations on the deck. These amplifications are defined in terms of transfer functions or transmissibility functions, which give the ratio of input motion to output motion as a function of frequency. From these calculations, resonant frequencies can be identified and fundamental periods predicted. Estimates of structural damping for each of the mode shapes can also be obtained.

The second objective of the deck level acceleration is to provide a means of calculating column displacement. The deck level acceleration can be processed to provide a displacement time-history. The displacement time-history, in conjunction with the support displacement and rotation, will provide the necessary data to calculate column deformations from which column stresses can be obtained. Because pier 2 is instrumented to calculate both support and bent rotation, exact column deformation in both the longitudinal and transverse directions can be calculated. Piers 1 and 2 are instrumented to calculate only transverse rotation of the support.

Because of the short span length, high longitudinal stiffness and absence of intermediate joints, it is likely that longitudinal deck displacement will be uniform from one end of the bridge to the other therefore, only three deck accelerometers are oriented longitudinally. Channels (20, 23, 36) will provide this acceleration data. Transverse motion of the bridge deck will be monitored by accelerometers at each bent and at the ends of the deck adjacent to the abutments; channels (33, 20, 24, 25, 36). These instruments will be used to identify the transverse mode shapes activated by the ground shaking.

### 9.7 Joint Monitoring

The recorded acceleration provided by channels (31, 32, 33) located at deck level adjacent to the west abutment, channels (34, 35, 36) located at deck level adjacent to the east abutment, channels (4, 5, 6) at the west abutment and channels (26, 27, 28) at the east abutment, will allow for the calculation of relative displacement between the deck and the abutments.

Comparison of the data recorded by accelerometers on the abutments and adjacent deck can be very informative. Relative displacements represent opening and closing of

the joint, pounding at the joint and joint filler damage can be identified from these records.

Because of the error encountered while processing acceleration data for displacement values (noise, recorder baseline corrections, numerical integration), relative displacement sensors will be installed as the primary means of capturing the relative displacement between the abutments and deck girders. In addition, the relative displacement sensors will record any permanent offset as a result of the shaking. The two outside girders at each abutment will be instrumented with a relative displacement sensor in order to provide the longitudinal relative displacement and rotation of the deck about the vertical axis. Channels (42, 43) and (44, 45) will record this data at the west and east abutments respectively. The deck is continuous between the abutments. Acceleration derived displacements will provide backup displacement data and a comparison between the relative displacement sensor values and acceleration values for the same displacement.

Transverse displacement of the deck will not be recorded because of the lateral restraint provided by the concrete shear keys. If shear keys are not used or if lateral displacement could possibly be excessive, additional relative displacement sensors should be installed. If additional sensors are not available, the deck and abutment accelerations data should be processed to provide this information.

#### 9.8 Bent Support Rotation

Vertical accelerometers, channels (29, 30) located at the bent extremes, will monitor the rotation of the bent support column 2. This will facilitate accurate evaluation of column deformation and induced shears and moments.

## 9.9 Vertical Mid-Span Acceleration

Research has shown that amplification of vertical acceleration at the mid-spans can be 2 to 3 times that of the support acceleration. As a result, channels (38, 39, 40, 41) will be installed at the four mid-spans to monitor the amplification between the support and deck accelerations. Channels (39, 40) located at mid-span of span 3, will provide the data necessary to calculate the torsion of the deck.

## 9.10 Non-Uniform Support Motion

Non-uniform support motion can be a concern on longer structures. Because of the relatively short distance of the Kealakaha Bridge, non-uniform support motion would not normally be investigated, but since recorders are already placed at the supports, soil-structure interaction as well as support rotation and translation can be investigated. Another area of investigation to be coupled with non-uniform support motion, is the phase delay of the shock wave and the direction prediction of the shock wave, which will verify epicentral direction.

## CHAPTER 10

### STRONG MOTION INSTRUMENT AND RECORDER INFORMATION

#### 10.1 Force Balance Accelerometers

Force Balance Accelerometers (FBA's) will be the primary means of obtaining strong motion acceleration data. Force Balance Accelerometers are conveniently small (measuring less than 6 inches in length for the triaxial models), extremely rugged (enclosed in a watertight housing) and very reliable. FBA's are capable of measuring acceleration up to  $\pm 4g$ . Although it depends on the expected Maximum Credible Earthquake (MCE) acceleration for the area, a  $\pm 1g$  FBA should be adequate for most seismic monitoring projects. All FBA's must be connected to a central recording device for the recording and storage of acceleration data. Figure 24 and 25 show two different manufactures' FBA's.

#### 10.2 Acceleration Recorders

Acceleration recorder systems have many standard and optional features. For the Kealakaha Bridge Project, the following are the minimum characteristics needed for the recorder system:

- Variability of Recorder Threshold Range. The threshold acceleration is the measured acceleration value which will start the recording of acceleration data from the FBA's. Threshold values for each accelerometer must be capable of being set independently of the other instruments, (i.e. deck level thresholds can be set higher than free-field thresholds). If any individual accelerometer threshold value is exceeded, then all instruments must begin recording. The

recorders must also be capable of setting a shut off threshold value, different from the start recording threshold, to stop the recording of the acceleration data.

- Pre-Event Memory. The recorder must have a pre-event memory feature which allows the recording of the acceleration data just prior to the threshold limit being exceeded. The amount of pre-event memory should be at least 5 seconds of data.
- Storage Capacity. The recorders must be capable of storing the acceleration data from the main seismic event and any additional aftershocks for all channels. A 25- minute storage capacity should be adequate.
- Remote Access to Data. Access to the recorded data shall be obtained by means of a permanently installed land line or cellular telephone via internal recorder modem.
- System Integrity. The recorders must have the ability to be interconnected and synchronized with additional recorder units.
- Timing of System. A GPS or equivalent external timing reference is critical. All of the instruments' recorded acceleration time-history must be referenced to this external reference.
- Power Supply. The recorders must be battery operated and connected to a solar powered recharge system.

Figures 26 and 27 show the recording systems available from two manufactures'.

### 10.3 Relative Displacement Sensors

Relative Displacement Sensors (RDS's) will be used to measure the relative displacement between the deck girders and the abutment. The RDS's must be compatible with the recording system to ensure time synchronization. Other RDS considerations are maximum stroke length (to account for not only maximum assumed seismic motion but

also bridge shortening and temperature variations) and resistance to the environment (to include temperature, humidity and shaking of the structure during the seismic activity).

#### 10.4 Instrument Vendors

The following are two possible instrument and recorder vendors:

**Kinematics**

222 Vista Avenue

Pasadena, CA 91107

Ph: (818) 795-2220

Fax: (818) 795-0868

**Terra Technology Corp.**

3854 148th Avenue NE

Redmond, WA 98052

Ph: (206) 883-7300

Fax: (206) 882-1412

## CHAPTER 11

### CONSTRUCTION AND DESIGN ISSUES

#### 11.1 As-built Material Properties

The recording of accurate as-built material properties is critical to the overall significance of analytical comparisons. Recorded as-built material properties will eliminate the assumption of material properties during stress calculations and during the development of the analytical models. For concrete, properties such as  $f'_c$  (concrete strength),  $f_r$  (modulus of rupture),  $E_c$  (concrete modulus of elasticity),  $\nu$  (Poisson's ratio), and  $\alpha$  (coefficient of thermal expansion) should be recorded. For steel, properties such as  $f_y$  (yield strength),  $f_{ult}$  (ultimate strength), and  $E_s$  (steel modulus of elasticity) should also be recorded. The requirement to provide material samples must be included in the construction contract. Actual testing of the material can either be performed at the University of Hawaii or by a commercial test laboratory as specified in the contract.

#### 11.2 Pile Cap Accelerometers

Two alternatives exist for the placement of accelerometers on the pile caps. Strong motion accelerometers are watertight and extremely rugged. The first option is to attach the recorders to the footings and cover them with the backfill material. This is a standard practice for new bridge structures instrumented by the CSMIP. A possible alternative is to construct a manhole which provides access to the accelerometers. It is suggested that manholes be provided for the instruments on the center support and that the others be buried in the backfill. Cable conduits will be installed in the pile caps and columns prior to pouring concrete. Overall, the instruments are very reliable and require no maintenance. The use of manholes would however allow for occasional inspection

and permit timely repairs at minimal cost, if necessary. The recording devices should be located so as to afford easy access, but out of direct sunlight and rain. Two possible locations are at the abutments or attached to the side of one of the columns.

### 11.3 Other Considerations

A number of issues must be coordinated during the design stage to avoid possible construction delays. It is suggested that a vendor be selected for instrument supply and installation during the design process so that their input can be incorporated into the final construction documents.

Construction issues include:

- Routing and installation of internal cable conduit prior to concrete pouring.
- Location and construction of free-field accelerometers base and protective shelter.
- Construction of access manholes over pile cap accelerometers prior to backfilling.
- Final location and installation schedule for all instruments.
- Final location and protective shelter for data recorders.
- Access to instrument locations below the deck for instrument installation.
- Any other issues raised by the instrument vendors.

## CHAPTER 12

### SUMMARY AND CONCLUSIONS

#### 12.1 Summary

This report outlines a proposed seismic instrumentation plan for the Kealakaha Stream Bridge. Based on a review of bridge instrumentation projects performed by the California Strong Motion Instrumentation Program (CSMIP), a comprehensive instrumentation program is developed and presented. The program utilizes 41 force balance accelerometers, 4 relative displacement sensors and the necessary data recorders. Suggestions are made regarding the installation procedure and other important aspects of the instrumentation project.

#### 12.2.1 Instrumentation Objectives

The seismic instrumentation and monitoring plan of the Kealakaha Stream Bridge was developed with a view toward answering the following questions:

- What are the fundamental and most significant natural frequencies of the structure and what damping is associated with each?
- What acceleration amplification can be expected at the top of the structure?
- How does the surrounding soil influence the structural response?
- How did the structure respond to the seismic event: was there substantial cracking, yielding, pounding, or excessive joint movement?
- Did the strong motion affect the characteristics of the structure? Did it 'soften' the structure and extend the fundamental period?
- Based on past performance, how will the structure respond to a Maximum Credible Earthquake (MCE)?

- How close was the analytical prediction to the actual response?
- What changes need to be made to improve the analytical model?

Knowing the answers to these questions will directly impact the design of future structures. In addition, these studies will provide an even greater understanding of earthquake resistant design which will lead to increased public safety.

#### 12.1.2 CSMIP Report Recommendations

The Kealakaha Stream Bridge instrumentation plan addressed the following problem areas as discussed in the three CSMIP reports:

- Time Synchronization. Not having all instruments referenced to a specific time will create error in the data during post processing because relative start times between the recording units must be calculated in order to match and compare the acceleration data. The Kealakaha Bridge plan will use a GPS timing reference, which will be part of the recorder system, to synchronize the timing for all instruments.
- Displacement Error. Calculation of the displacement time-history from acceleration data introduced errors resulting from noise, acceleration baseline corrections and numerical integration. In order to eliminate this error, Relative Displacement Sensors (RDS's) were installed to measure joint relative displacement directly.
- Free-Field Motion. Free-field acceleration is a critical element in the study of soil-structure interaction. Care has been taken to determine the optimal location of the free-field instruments in the Kealakaha plan. If the free-field instruments are too close to the structure, recorded free-field acceleration will be influenced by the presence of the structure. If the free-field instruments are located too far away, the soil properties and profiles at the structure and free-field locations

may not be the same. For the Kealakaha Bridge, free-field instruments will be located approximately 75 feet south of pier 2 (Figure 21).

- Extensive Foundation Data. Lack of adequate data regarding footing motion and rotation, limited potential research in the CSMIP reports. The Kealakaha plan calls for considerable instrumentation of the pile caps in order to investigate soil-structure interaction effects, accurately calculate column deformation by measuring support rotation, and aid in analytical modeling by providing input data, which can be used to isolate the structure from the soil.
- Accurate Material Properties. In the CSMIP reports, assumptions had to be made during analytical modeling because as-built material properties were not know. By working with the designers and contractors, the Kealakaha plan will provide this important information, thereby eliminating the error introduced into the analytical models from assumptions of these values.

## 12.2 Conclusion

The Kealakaha Stream Bridge seismic instrumentation and monitoring plan will assist in understanding and predicting the structure's response to strong ground motion. The CSMIP reports discussed earlier present various theories about the structural response of bridges, but these must be tested by further research. The seismic instrumentation of the Kealakaha Bridge will provide the type of data necessary to evaluate these theories. Most of the CSMIP instrumentation was performed on existing structures, though Federal and State projects are increasingly incorporating seismic instrumentation into new structures. By designing an instrumentation plan and objectives prior to construction, many of the pitfalls of previous instrumentation programs can be avoided.

## REFERENCES

AASHTO-83, (1988), Guide Specifications For Seismic Design OF Highway Bridges, American Association of State Highway and Transportation Officials, Washington, D.C.

ATC-6, (1981), Seismic Design Guidelines for Highway Bridges, Applied Technology Council, Berkeley, CA.

CALTRANS, (1989), Bridge Design Aids 14-1, California Department of Transportation, Sacramento, CA.

Clague, D., (1995, March), Geological Hazards In Hawaii, Hawaii Volcano Observatory, U.S. Geological Survey.

Fennes, G. L., and Desroches, R., (1995, March), CSMIP/95-02 Data Utilization Report, Evaluation Of The Response Of I-10/215 Interchange Bridge Near San Bernardino In The 1992 Landers And Big Bear Earthquakes, Office of Strong Motion Studies, Sacramento, CA.

Goel, R. K., and Chopra, A. K., (1995, March), CSMIP/95-01 Data Utilization Report, Seismic Response Study Of The Hwy 101/Painter Street Overpass Near Eureka Using Strong-Motion Records, Office of Strong Motion Studies, Sacramento, CA.

HDOT, (1995, September), Draft Environmental Assessment For Kealakaha Stream Bridge Replacement Project No. BR-019-2(26), Hawaii Department of Transportation, Honolulu, HI.

ICBO, (1994), Uniform Building Code, 1994, Volume 2, International Conference of Building Officials, Whittier, CA.

Klein, F., (1994), Seismic Hazards at Kilauea And Mauna Loa Volcanoes, Hawaii, Report 94-216, U.S. Geological Survey, Menlo Park, CA.

Schnabel, P. B., Lysmer, J., Seed, H. B., (1972, December), SHAKE: A Computer Program For Earthquake Response Analysis Of Horizontally Layered Sites, Report No. EERC 72-12, Berkeley, CA.

Tseng, W. S., Yang, M S., and Penzien J., (1992, September), CSMIP/92-02 Data Utilization Report, Seismic Performance Investigation Of The Hayward BART Elevated Section, Office of Strong Motion Studies, Sacramento, CA.

Table 1. Location of Strong Motion Accelerometers on Northwest Connector and Maximum Response in Landers and Big Bear Earthquakes (From: Fenves, 1995).

Channel	Location	Direction	Landers Earthquake		Big Bear Earthquake	
			Peak Accel. (g)	Peak Displ. (in.)	Peak Accel. (g)	Peak Displ. (in.)
1	Abut 1	L	0.535	3.23	0.401	2.04
2	Abut 1	V	0.187	1.02	0.099	0.33
3	Abut 1	T	0.243	1.93	0.189	1.26
4	Bent 3, Footing	L	0.103	2.78	0.085	1.07
5	Bent 8, Footing, North Side	V	0.107	1.07	0.075	0.49
6	Bent 3, Footing	T	0.099	2.38	0.110	1.24
7	Hinge 3, West Side	T	0.297	6.30	0.379	5.91
8	Hinge 3, East Side	T	0.553	6.61	0.449	6.22
9	Bent 7, Deck	V	0.197	2.49	0.176	1.89
10	Hinge 3, West Side	L	0.450	3.04	0.344	1.39
11	Midspar, Bents 5 and 6, Deck	T	0.393	9.76	0.287	6.73
12	Bent 8, Deck; North Side	V	0.258	2.36	0.214	2.07
13	Bent 8, Deck, South Side	V	0.354	3.27	0.225	1.49
14	Midspar, Bents 7 and 8, Deck	V	0.372	2.34	0.312	1.95
15	Hinge 7, North Side	V	0.346	2.50	0.311	1.98
16	Hinge 7, South Side	V	0.430	3.31	0.310	1.51
17	Hinge 7, West Side	L	0.638	2.59	0.342	3.11
18	Hinge 7, East Side	L	0.712	1.93	0.565	2.08

L=Longitudinal (tangential); T=Transverse (radial), V=Vertical (up).

Table 1 (Continued). Location of Strong Motion Accelerometers on Northwest Connector and Maximum Response in Landers and Big Bear Earthquakes (From: Feives, 1995).

Channel	Location	Direction	Landers Earthquake		Big Bear Earthquake	
			Peak Accel. (g)	Peak Displ. (in.)	Peak Accel. (g)	Peak Displ. (in.)
19	Hinge 7, West Side	T	0.512	10.47	0.496	5.20
20	Hinge 7, East Side	T	0.392	10.28	0.329	4.68
21	Not Used	—	—	—	—	—
22	Bent 8, Footing, South Side	L	0.163	1.34	0.250	1.21
23	Bent 8, Footing, South Side	V	0.072	1.11	0.082	0.49
24	Bent 8, Footing, South Side	T	0.179	4.88	0.147	1.60
25	Hinge 9, West Side	T	0.323	6.38	0.255	3.02
26	Hinge 9, East Side	T	0.298	6.26	0.251	3.00
27	Not Used	—	—	—	—	—
28	Hinge 11, West Side	L	0.281	2.82	0.361	2.35
29	Hinge 11, West Side	T	0.288	7.55	0.302	5.51
30	Hinge 11, East Side	T	0.432	7.68	0.406	5.71
31	Hinge 13, West Side	T	0.357	4.49	0.836	4.02
32	Hinge 13, East Side	T	0.413	4.13	0.450	3.75
33	Hinge 11, East Side	L	0.792	2.81	0.663	2.15
34	Abut 17	L	0.322	3.28	0.222	1.44
35	Abut 17	V	0.102	1.03	0.097	0.39
36	Abut 17	T	0.139	3.16	0.190	1.56

L=Longitudinal (tangential); T=Transverse (radial), V=Vertical (up).

**Table 2. Kealakaha Bridge Proposed Seismic Instrumentation Locations, Description and Objectives.**

<b>Channel</b>	<b>Location</b>	<b>Direction<sup>1</sup></b>	<b>Objective</b>
1	Free Field, South Side	L	Free field strong motion on South side of the structure
2	Free Field, South Side	V	Free field strong motion on South side of the structure
3	Free Field, South Side	T	Free field strong motion on South side of the structure
4	West Abutment	L	Abutment displacement
5	West Abutment	V	Abutment displacement
6	West Abutment	T	Abutment displacement
7	Pier 1, Footing, North Side	V	Pick-up rotation of pile cap about the longitudinal axis
8	Pier 1, Footing, South Side	V	Pick-up rotation of pile cap about the longitudinal axis and compare with free field motion
9	Pier 1, Footing, South Side	L	Longitudinal displacement at the base of Pier 1 and compare with free field motion
10	Pier 1, Footing, South Side	T	Transverse displacement at the base of Pier 1 and compare with free field motion
11	Pier 2, Footing, North Side	V	Pick-up rotation of pile cap about the longitudinal axis
12	Pier 2, Footing, South Side	V	Pick-up rotation of pile cap about the longitudinal and transverse axis and compare with free field motion
13	Pier 2, Footing, South Side	L	Longitudinal displacement at the base of Pier 2 and compare with free field motion
14	Pier 2, Footing, South Side	T	Transverse displacement at the base of Pier 2 and compare with free field motion
15	Pier 2, Footing, West Side	V	Pick-up the pile cap rotation about the transverse axis
16	Pier 3, Footing, North Side	V	Pick-up rotation of pile cap about the longitudinal axis
17	Pier 3, Footing, South Side	V	Pick-up rotation of pile cap about the longitudinal axis and compare with free field motion
18	Pier 3, Footing, South Side	L	Longitudinal displacement at the base of Pier 3 and compare with free field motion

Table 2 (Continued). Kealakaha Bridge Proposed Seismic Instrumentation Locations, Description and Objectives.

19	Pier 3, Footing, South Side	T	Transverse displacement at the base of Pier 3 and compare with free field motion
20	Pier 1, Deck, South Side	T	Transverse displacement at the top of Pier 1
21	Pier 2, Deck, North Side	V	Pick-up deck rotation about the longitudinal axis
22	Pier 2, Deck, South Side	V	Pick-up deck rotation about the longitudinal axis
23	Pier 2, Deck, South Side	L	Longitudinal displacement at the top of Pier 2
24	Pier 2, Deck, South Side	T	Transverse displacement at the top of Pier 2
25	Pier 3, Deck, South Side	T	Transverse displacement at the top of Pier 3
26	East Abutment	V	Abutment displacement
27	East Abutment	L	Abutment displacement
28	East Abutment	T	Abutment displacement
29 <sup>2</sup>	Pier 2, Bent, West Side	V	Rotation of Bent 2 about the transverse axis
30 <sup>2</sup>	Pier 2, Bent, East Side	V	Rotation of Bent 2 about the transverse axis
31	Deck adj. to West Abutment	V	Relative motion between deck and abutment.
32	Deck adj. to West Abutment	L	Relative motion between deck and abutment.
33	Deck adj. to West Abutment	T	Relative motion between deck and abutment.
34	Deck adj. to East Abutment	V	Relative motion between deck and abutment.
35	Deck adj. to East Abutment	L	Relative motion between deck and abutment.
36	Deck adj. to East Abutment	T	Relative motion between deck and abutment.
37	Midspan, Span 1	V	Acceleration amplification and to record deck deformed shape
38	Midspan, Span 2	V	Acceleration amplification and to record deck deformed

**Table 2 (Continued). Kealakaha Bridge Proposed Seismic Instrumentation Locations, Description and Objectives.**

			shape
39	Midspan, Span 3	V	Acceleration amplification, record deck deformed shape and torsion of deck
40	Midspan, Span 4	V	Acceleration amplification and to record deck deformed shape
41	Midspan, Span 3, North Side	V	Acceleration amplification, record deck deformed shape and torsion of deck
42	North Girder, West Abutment	Displ Sensor	Longitudinal displacement of girder relative to abutment and rotation of the deck about the vertical axis
43	South Girder, West Abutment	Displ Sensor	Longitudinal displacement of girder relative to abutment and rotation of the deck about the vertical axis
44	North Girder, East Abutment	Displ Sensor	Longitudinal displacement of girder relative to abutment and rotation of the deck about the vertical axis
45	South Girder, East Abutment	Displ Sensor	Longitudinal displacement of girder and rotation of the deck about the vertical axis

<sup>1</sup> L = Longitudinal  
T = Transverse to bridge centerline  
V = Vertical

<sup>2</sup> These two accelerometers depend on whether the structure is built using this type of system.

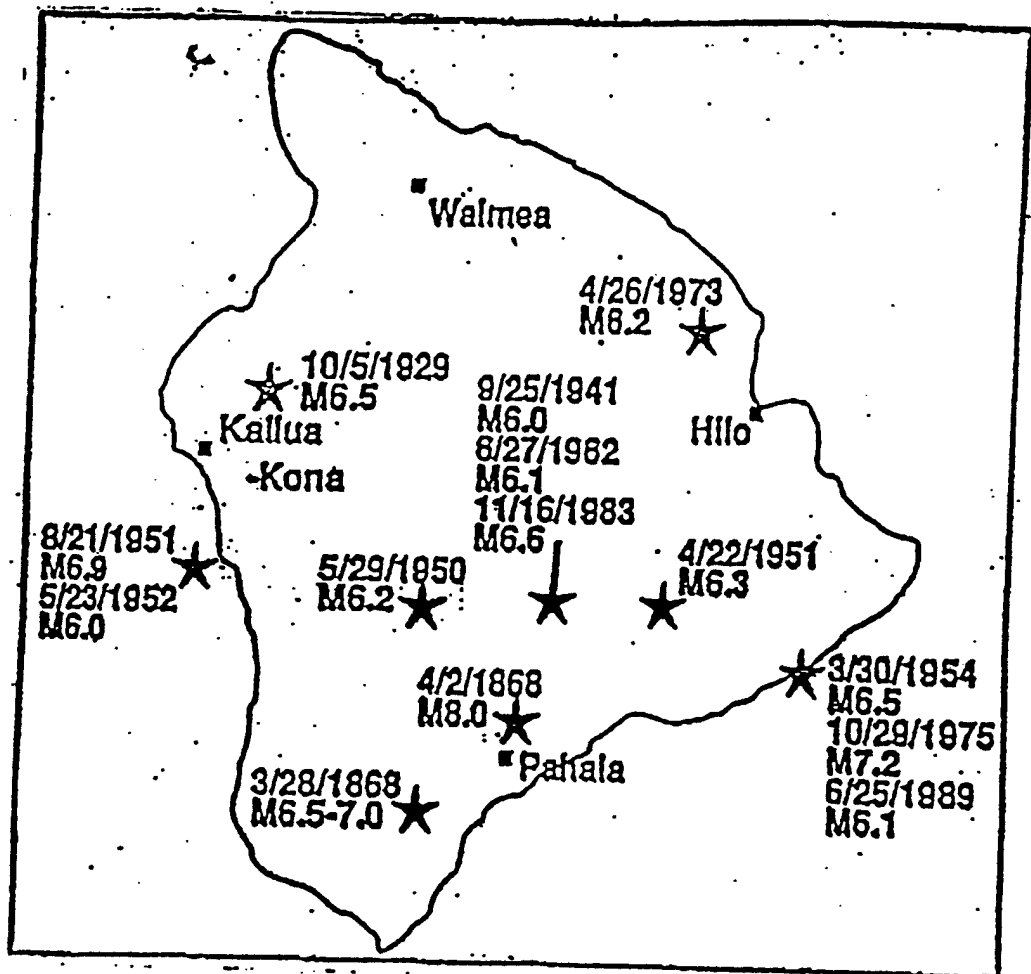

Figure 1. Historical Island of Hawaii Earthquakes with Magnitude Greater than 6.0 (From: Clague, 1995).

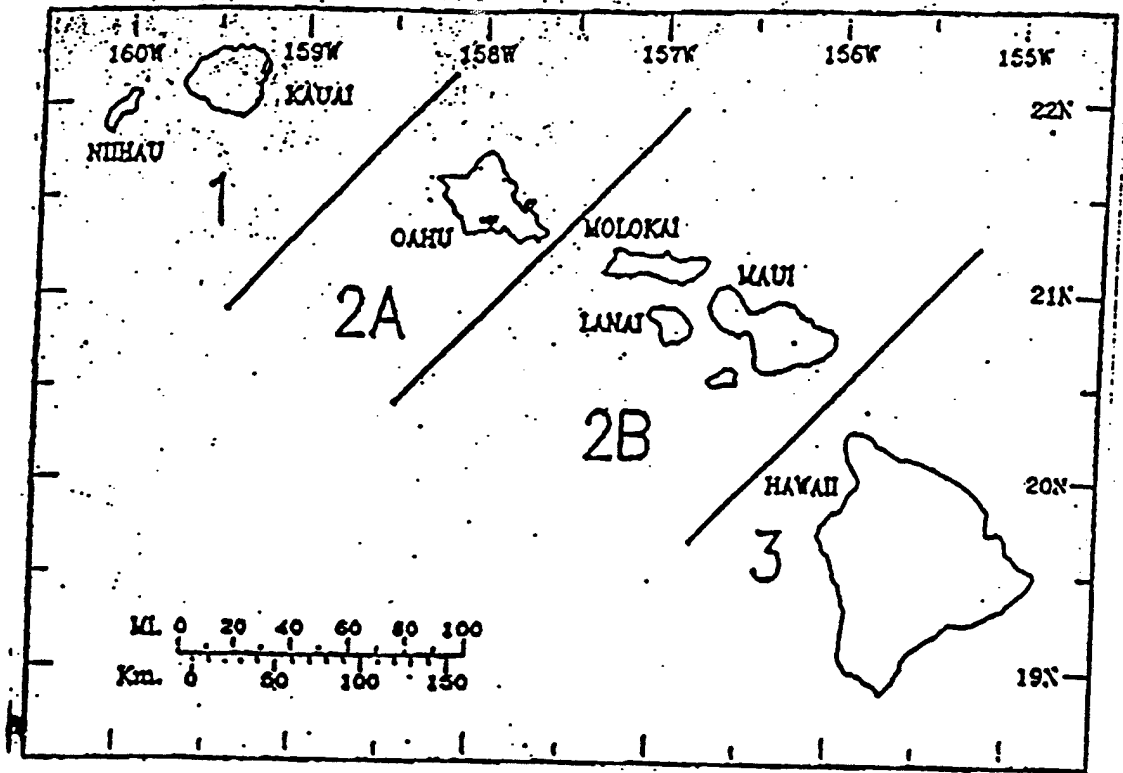

Figure 2. Current Seismic Zonation for the Hawaiian Islands  
(From: UBC, 1994).

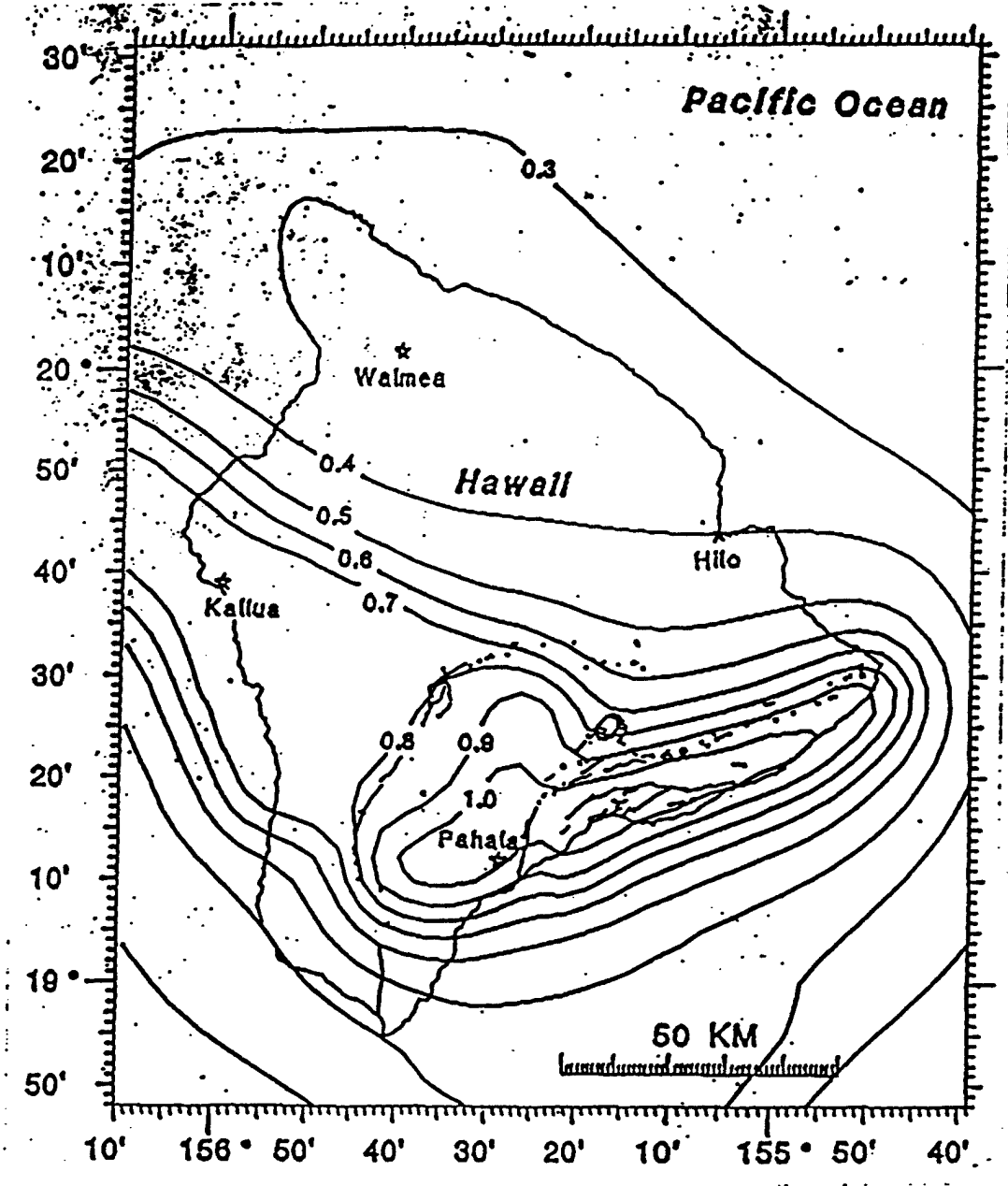

Figure 3. Peak Ground Acceleration (in g) for a 50 Year Exposure Time with a 90% Probability of Not Being Exceeded (From: Klein, 1995).

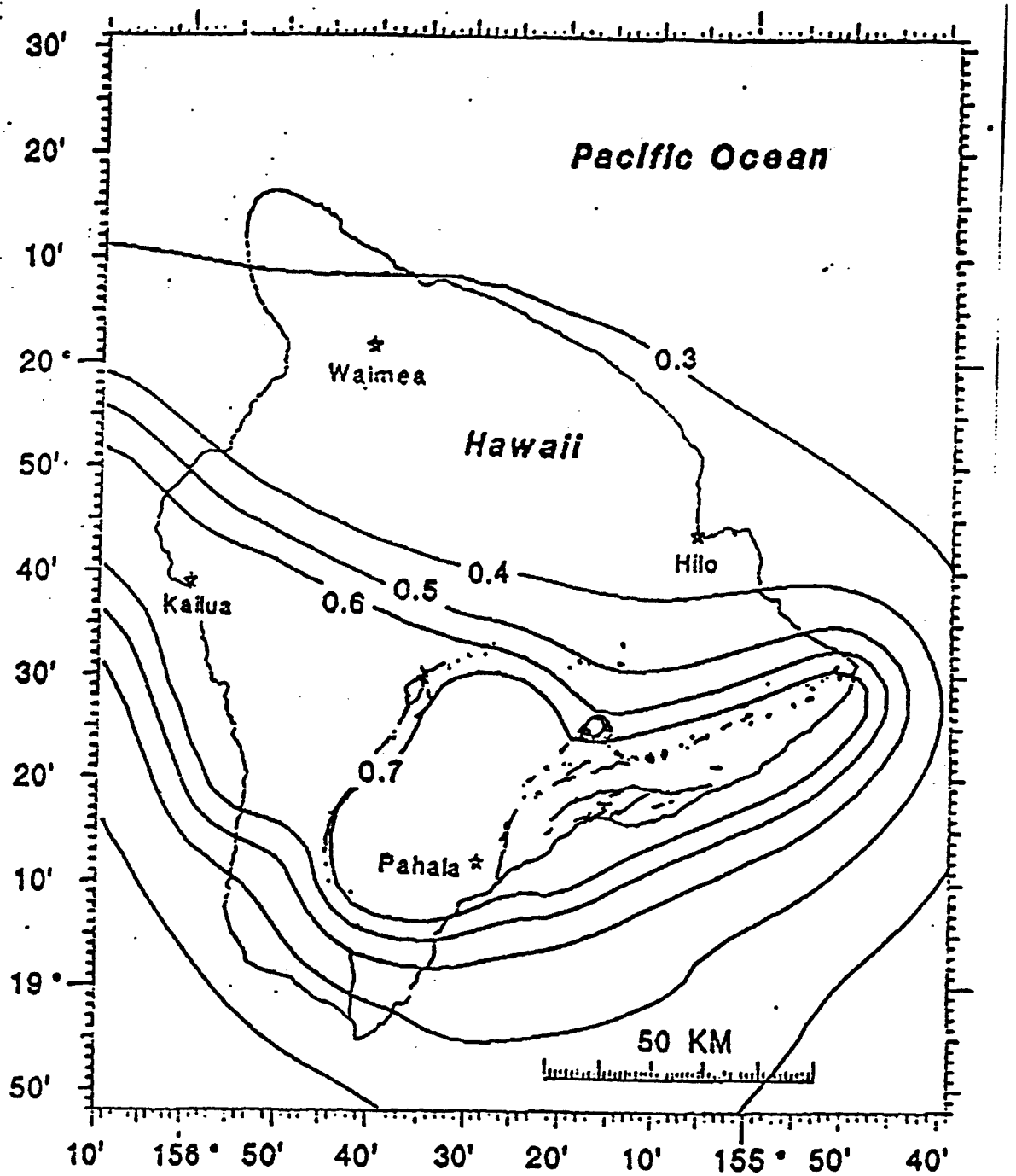

Figure 4. Effective Peak Ground Acceleration (in g) for a 50 Year Exposure Time with a 90% Probability of Not Being Exceeded (From: Klein, 1995).

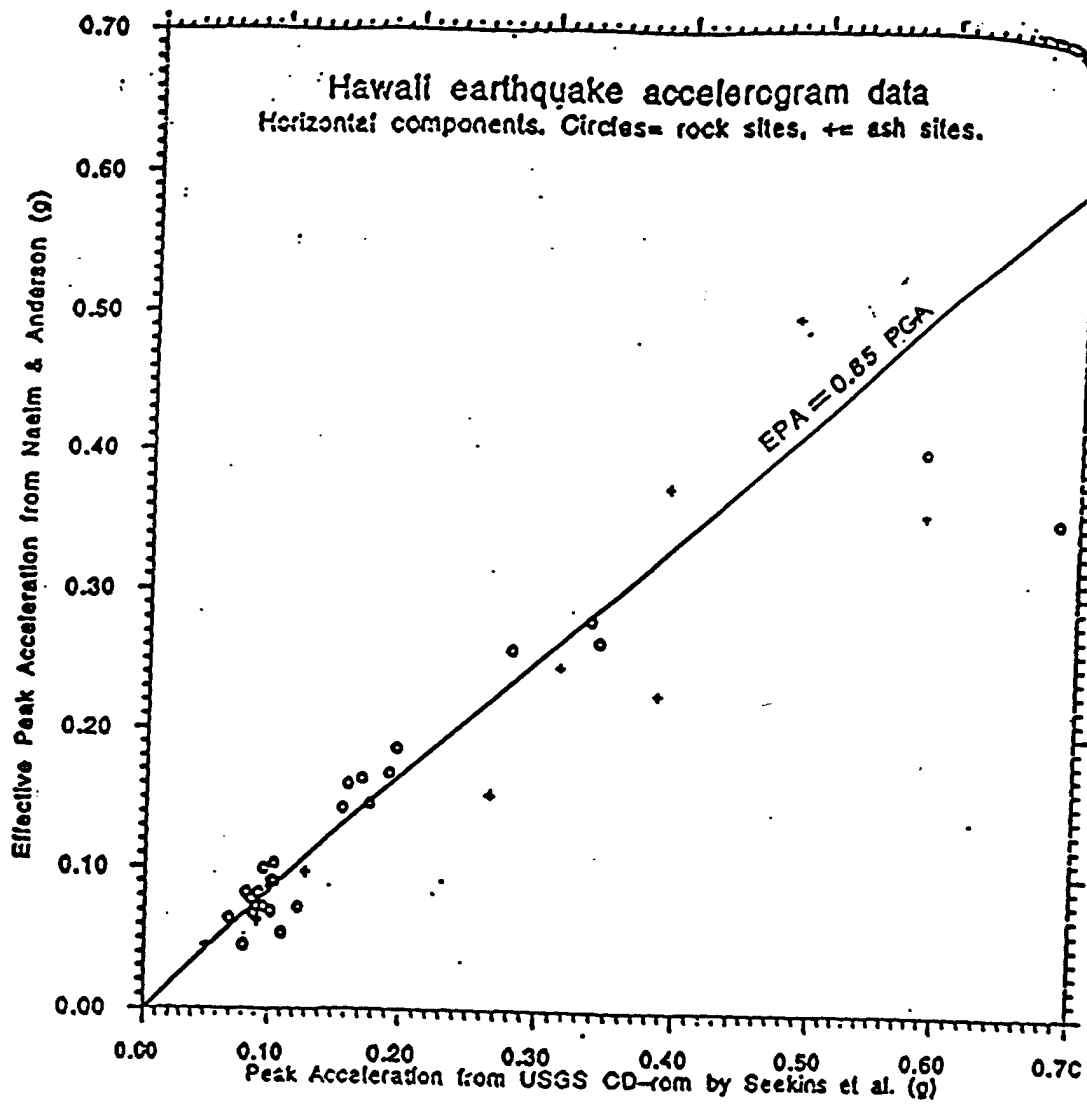

Figure 5. Comparison of Peak Ground Acceleration (PGA) and Effective Peak Ground Acceleration (EPA) for Three Hawaiian Earthquakes (From: Klein, 1995).

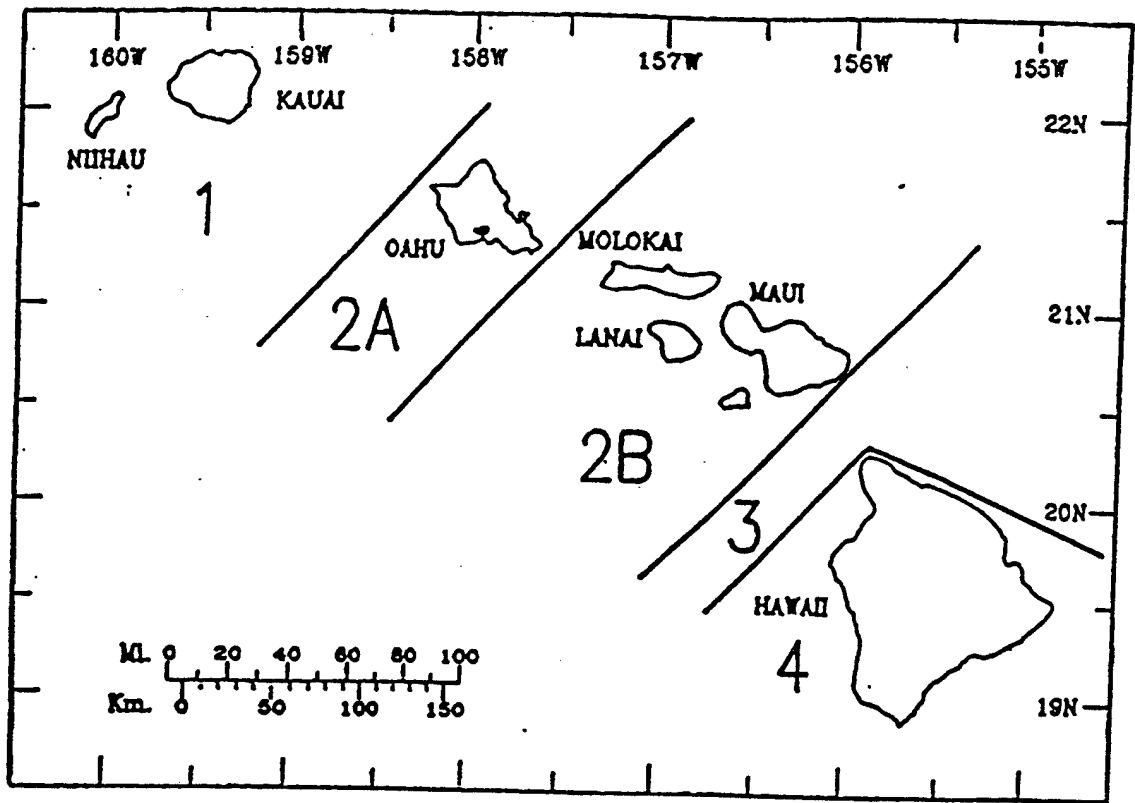

Figure 6. Proposed Seismic Zonation for the Hawaiian Islands (From: Klein, 1995).

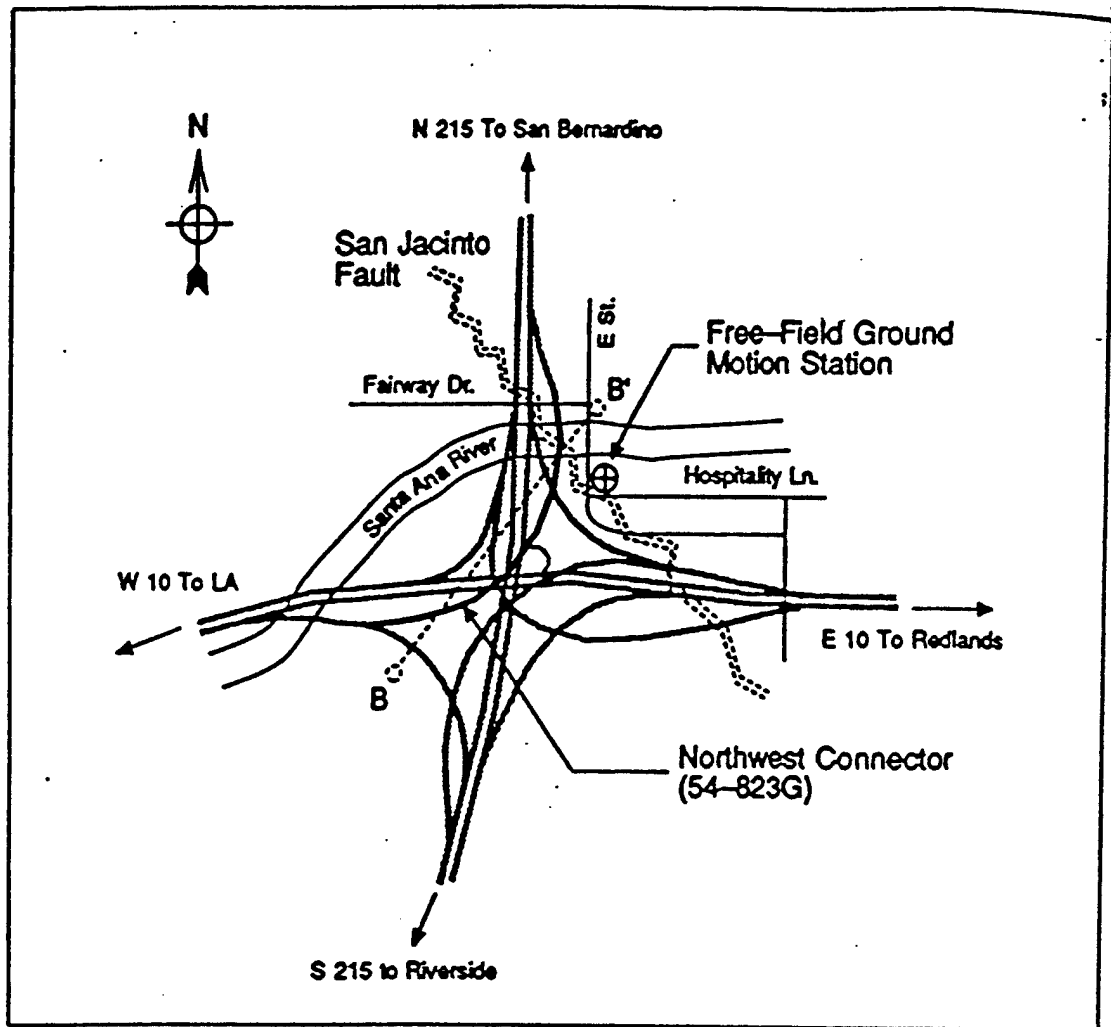

Figure 7. Schematic Plan of the Interstate 10/215 Interchange in Colton, California (From: Fenves, 1995).

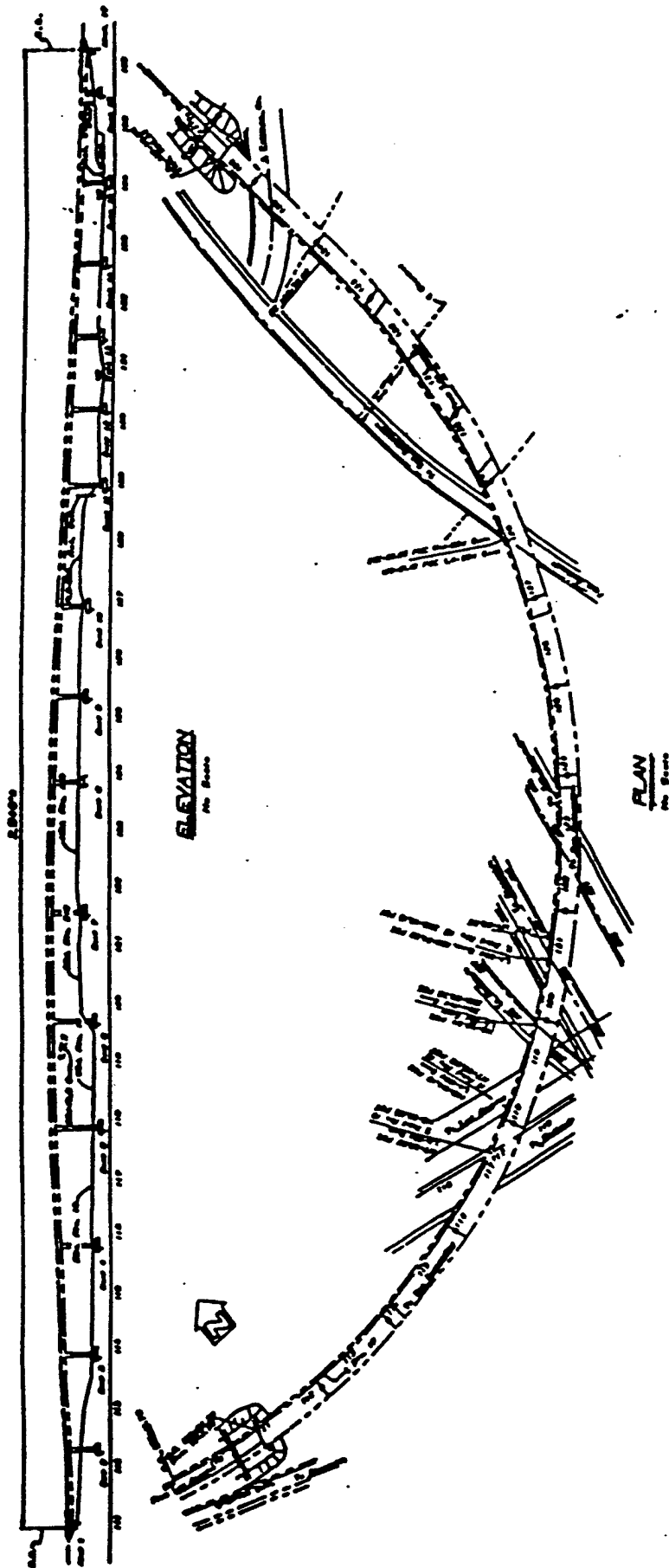

Figure 8. General Plan of Northwest Connector (From: Fenves, 1995).

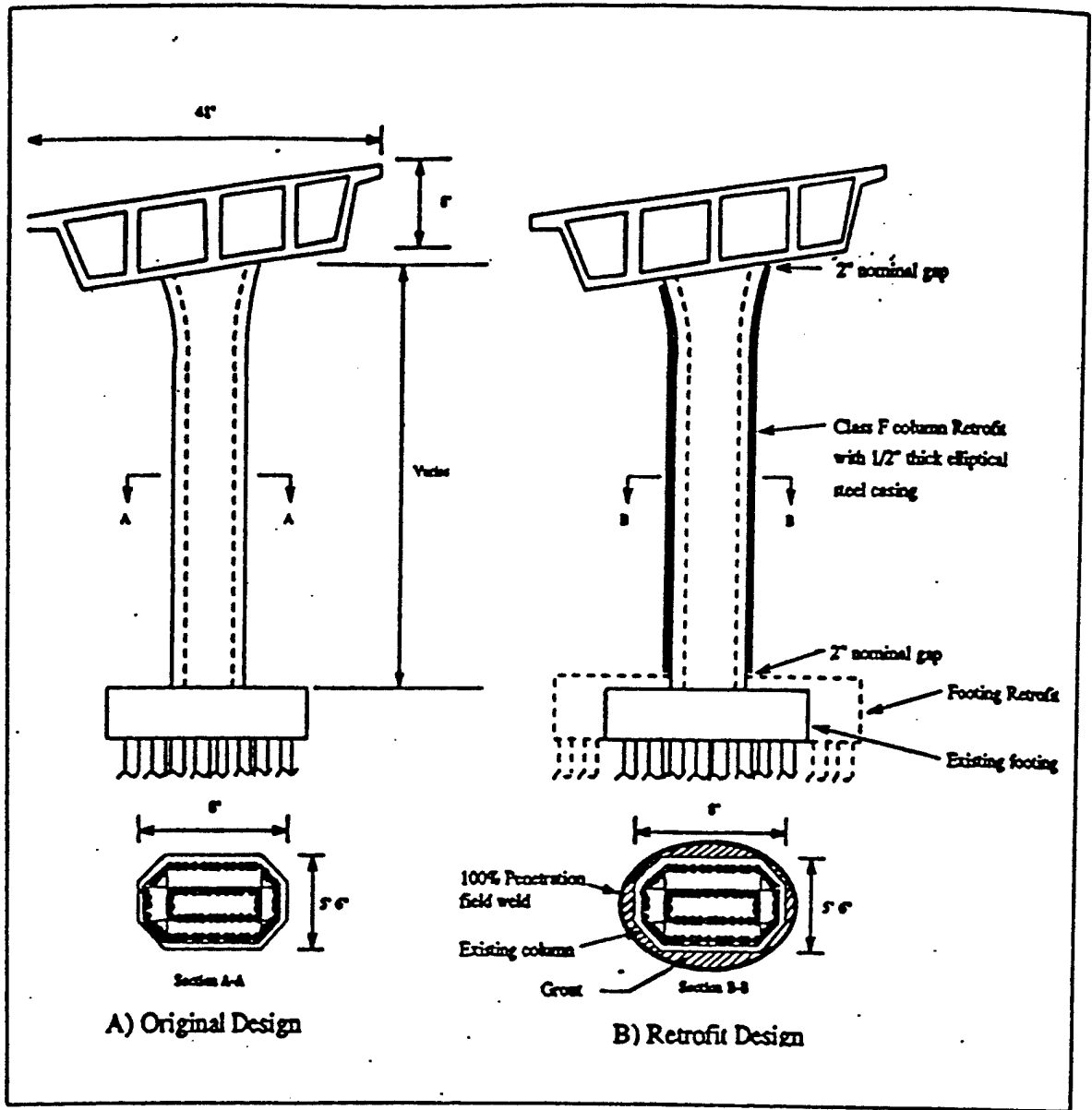

Figure 9. Single Column Bent and Box Girder Cross-Section. Original and Retrofit Design (From: Fenves, 1995).

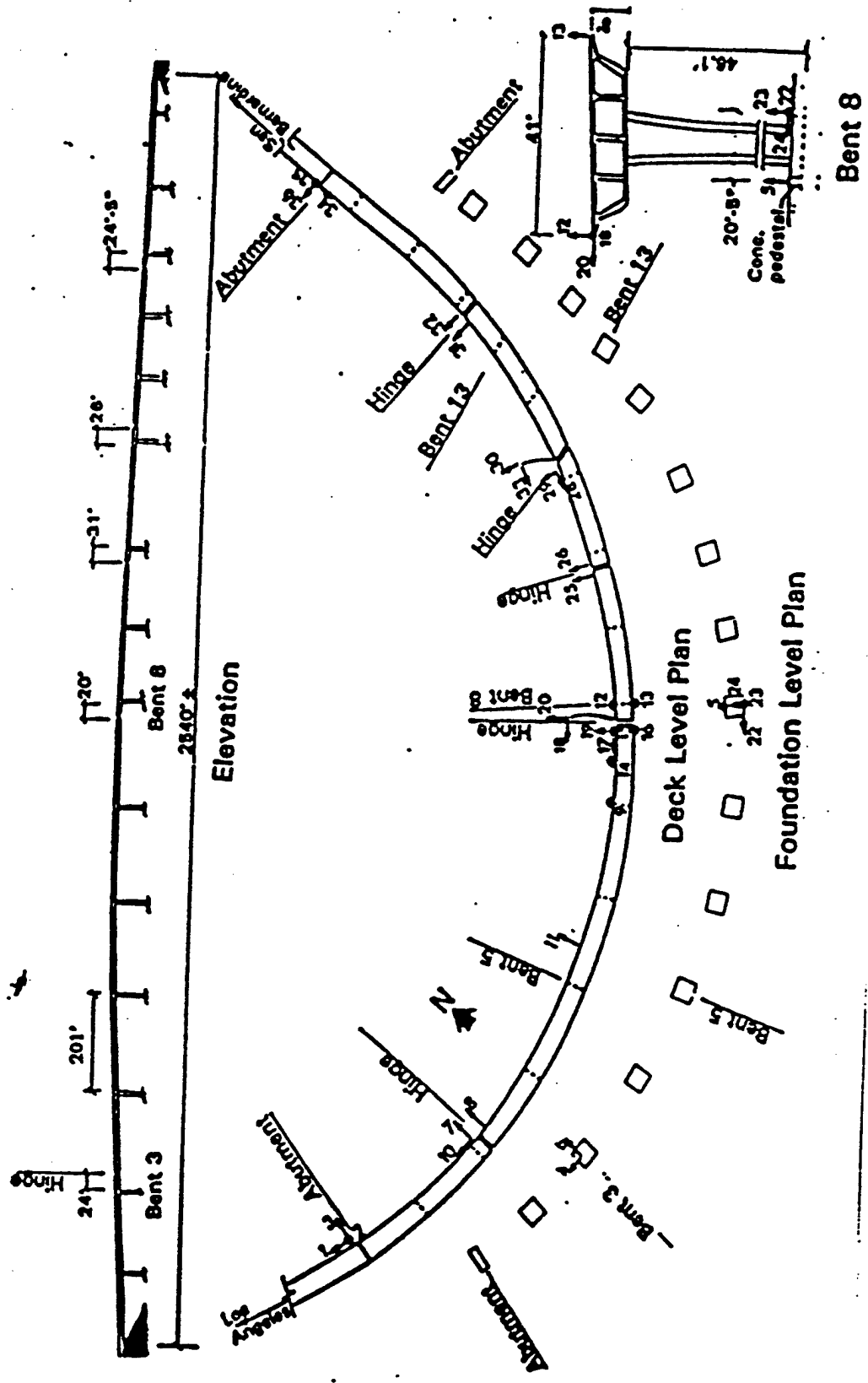

Figure 10. Seismic Instrumentation for the Northwest Connector (From: Fennes, 1995).

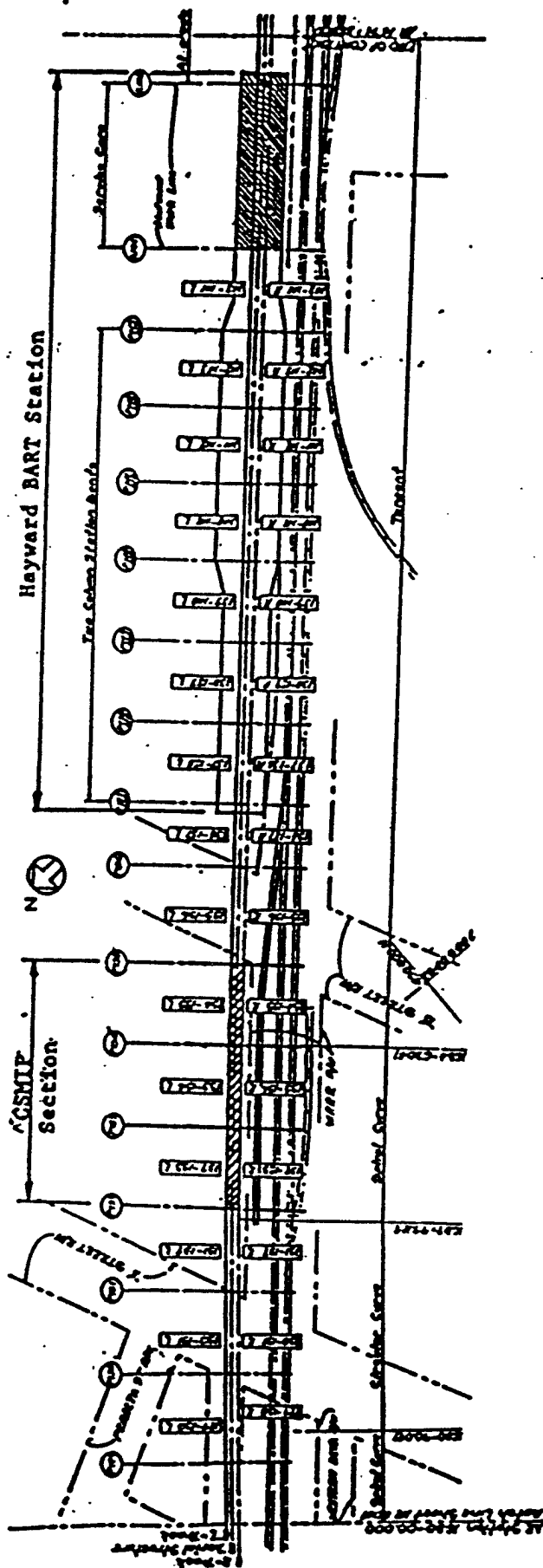

Figure 11. Location of the CSMIP- Instrumented BART Elevated Structure Relative to Hayward BART Station (From: Tseng, 1992).

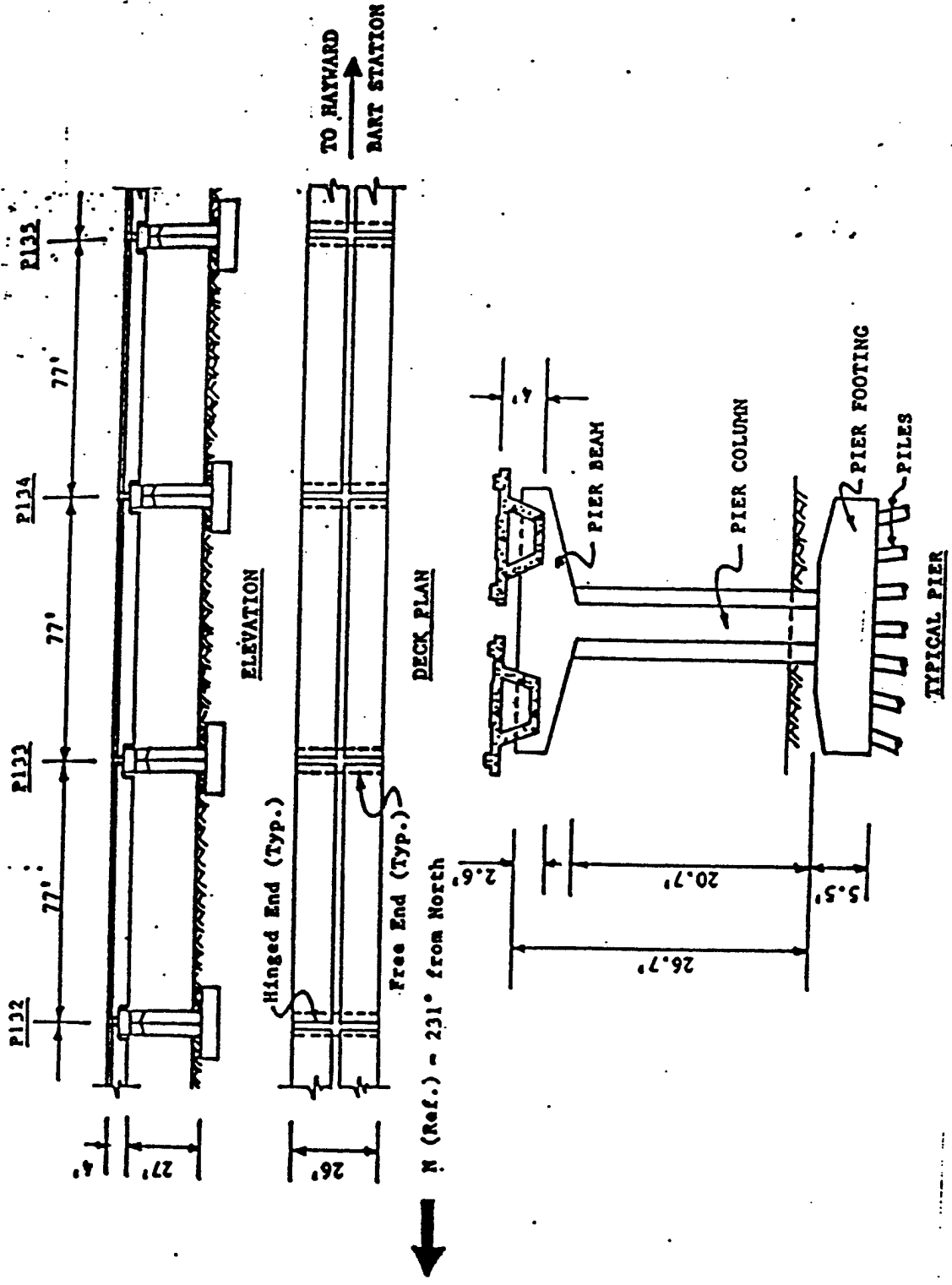

Figure 12. Structural Configuration and Dimensions of the CSMIP- Instrumented Section (From: Tseng, 1992).

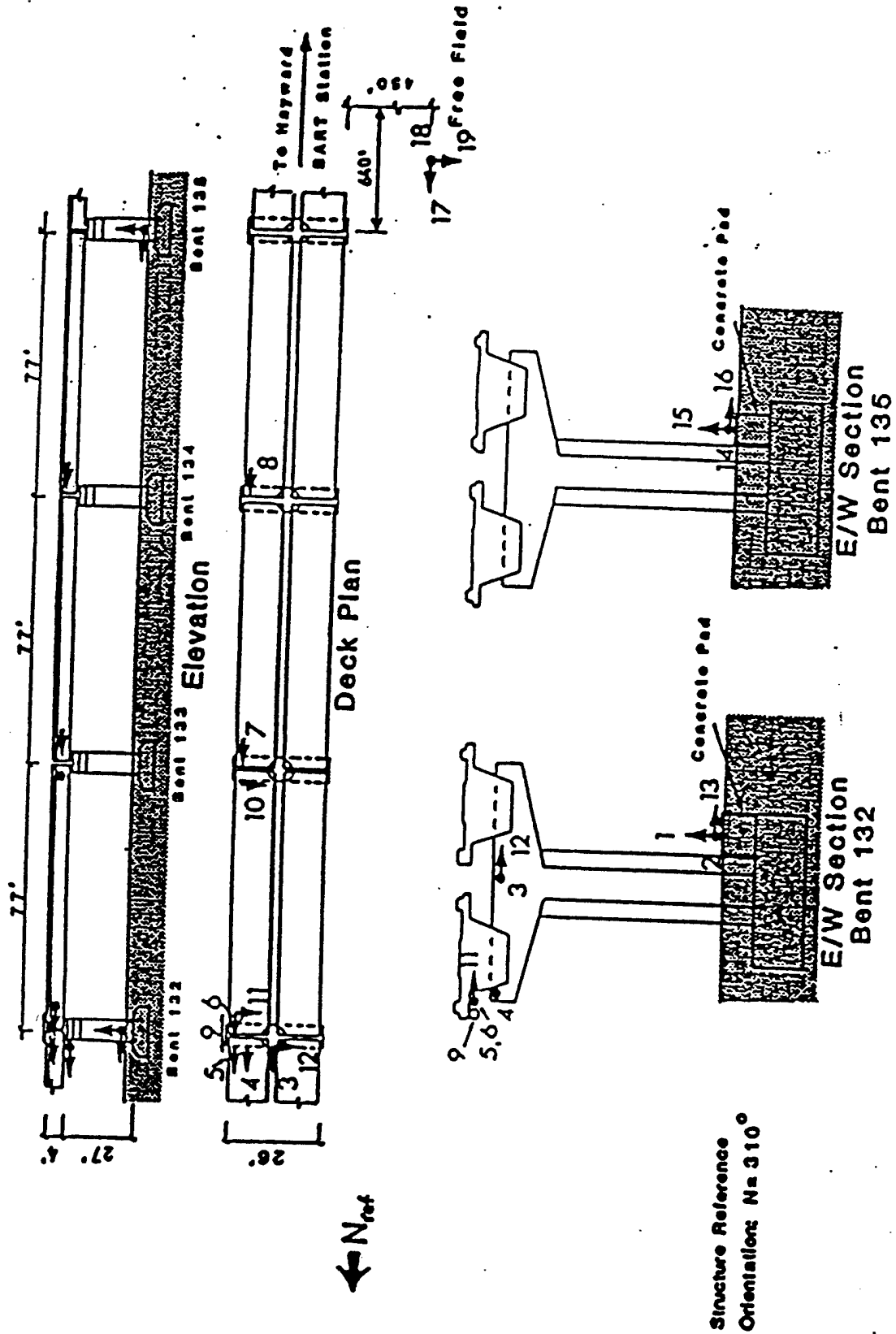

Figure 13. Instrumentation Locations on the Hayward-BART Elevated Section (From: Tseng, 1992).

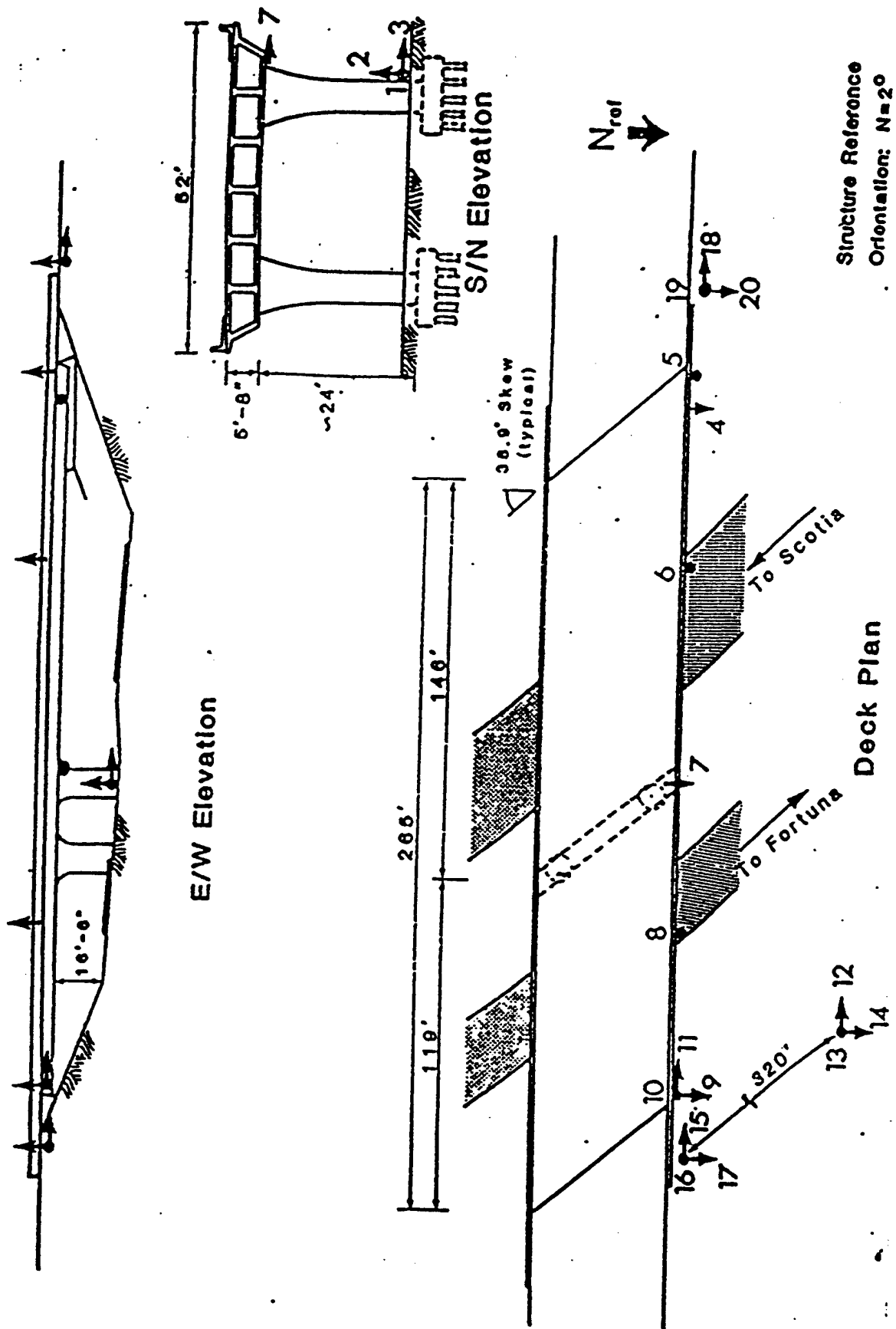

Figure 14. US 101/Painter Street Overpass: Structural Details and Instrument Locations (Goel, 1995).

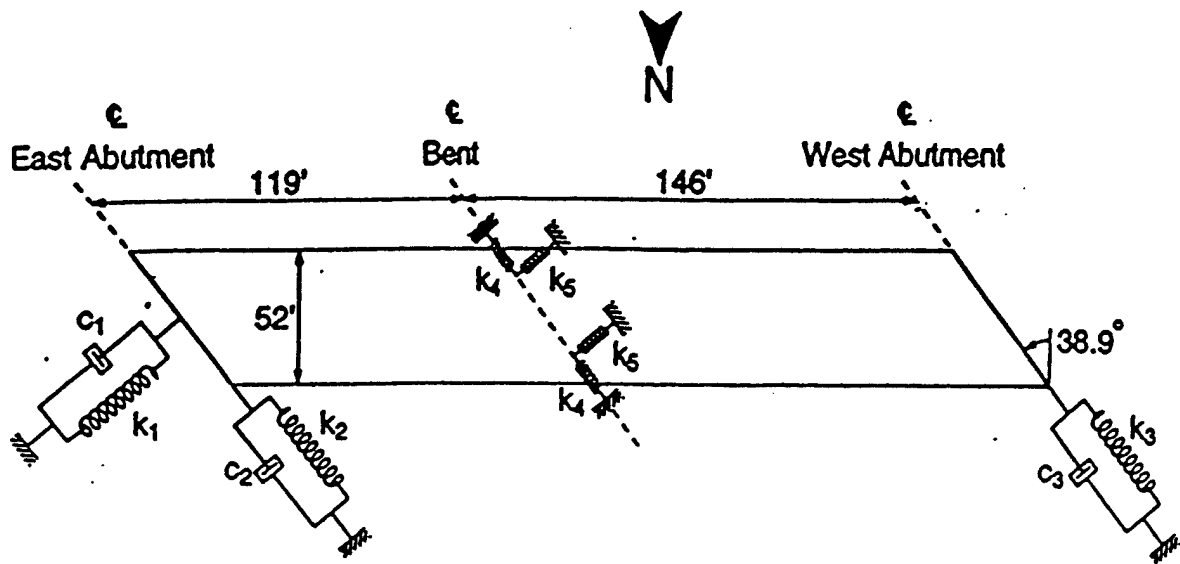

Figure 4. Idealized model of US 101/Painter Street Overpass

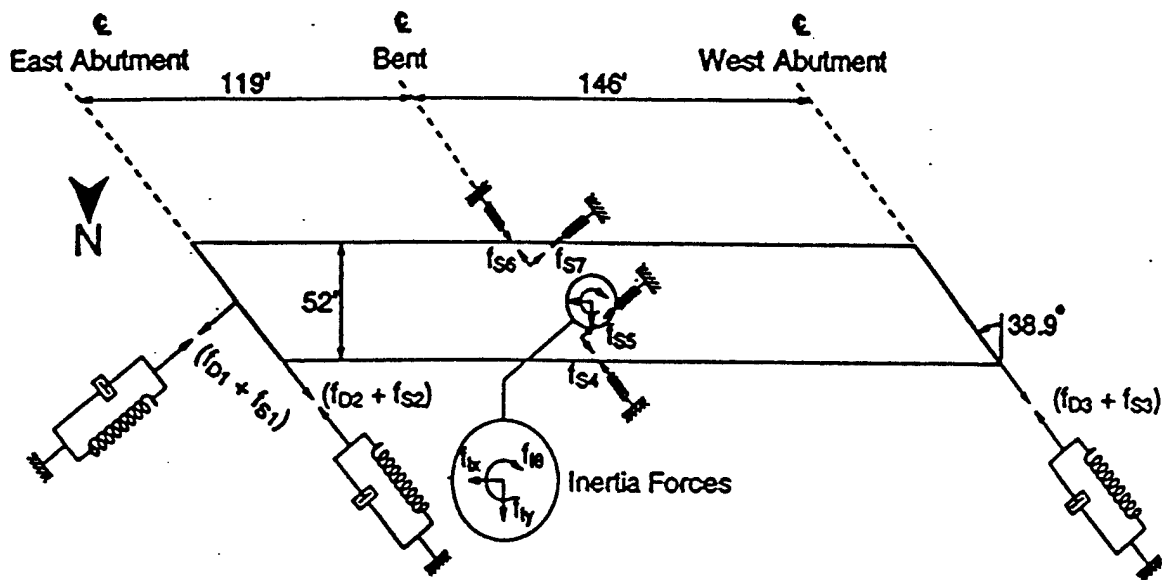

Figure 15. Free-Body Diagram for Structural Idealization of US 101/Painter Street Overpass (Goel, 1995).



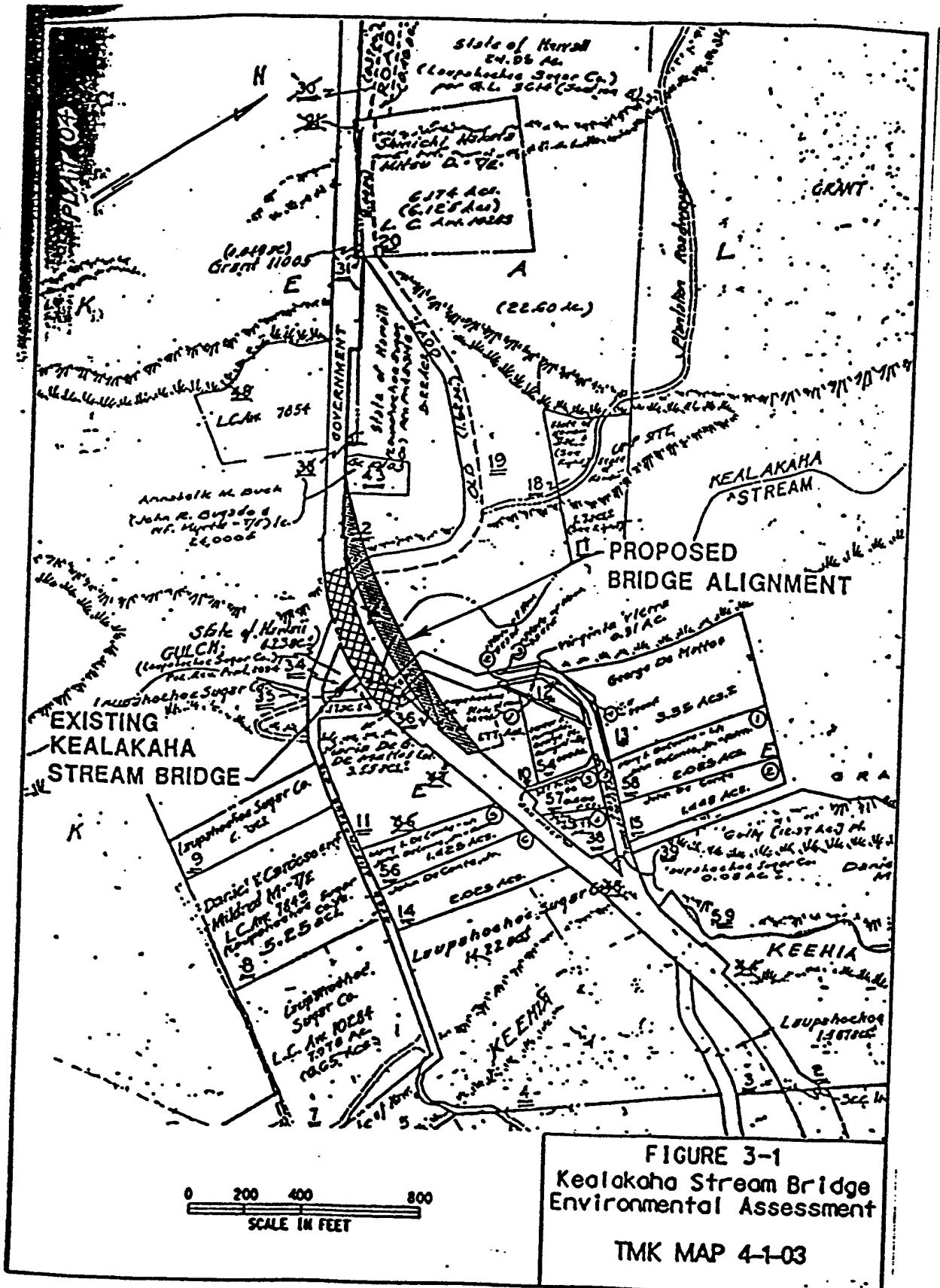

Figure 17. Proposed Kealakaha Stream Bridge Alignment (From: HDOT, 1995).

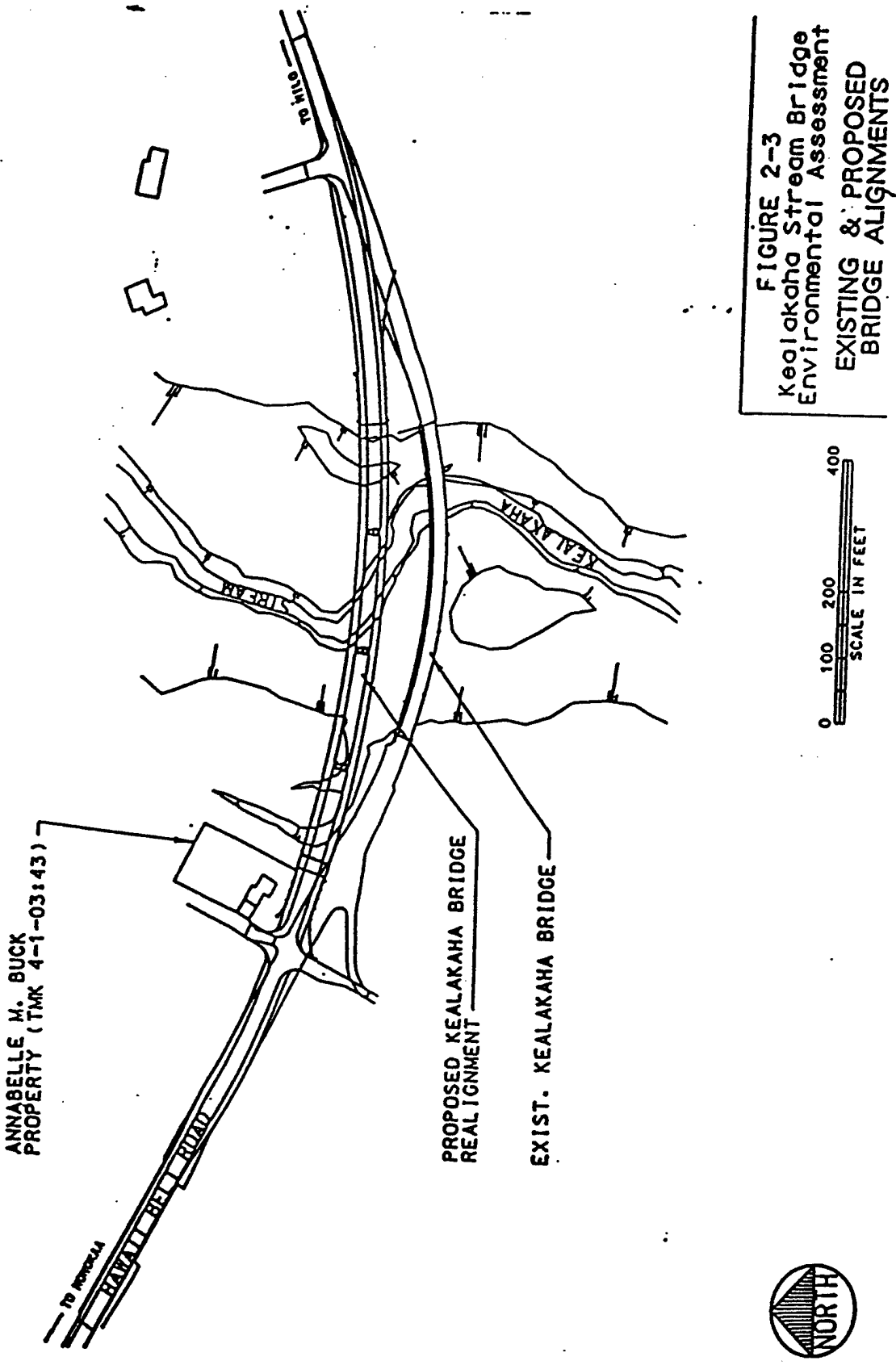

Figure 18. Existing and Proposed Kealakaha Stream Bridge Alignment  
(From: HDOT, 1995).

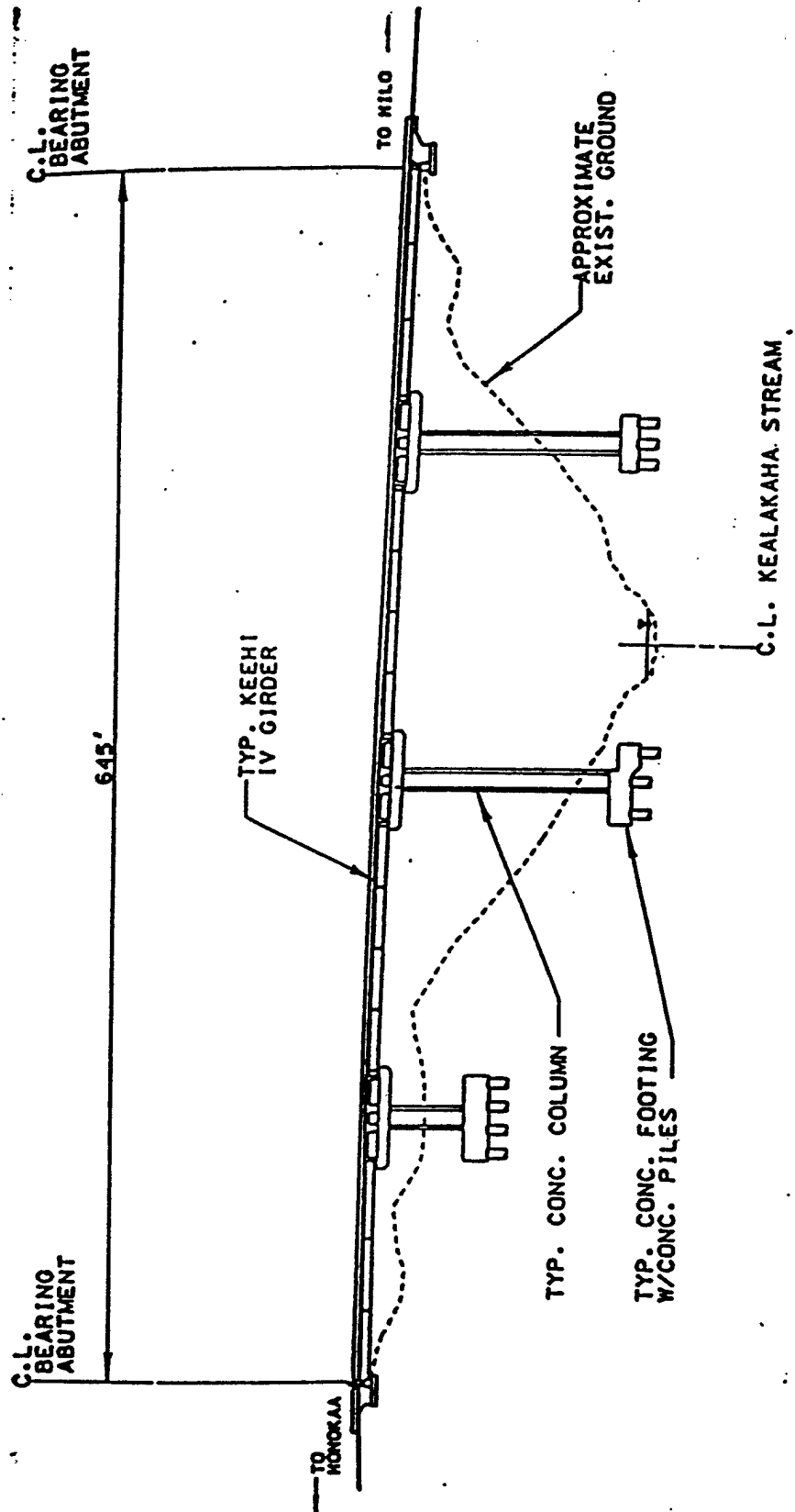

FIGURE 2-4  
Kealakaha Stream Bridge  
Environmental Assessment  
LONGITUDINAL SECTION  
OF PROPOSED BRIDGE

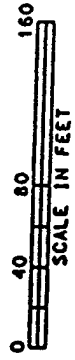

Figure 19. Longitudinal Section of New Proposed Kealakaha Stream Bridge  
(From: HDOT, 1995).

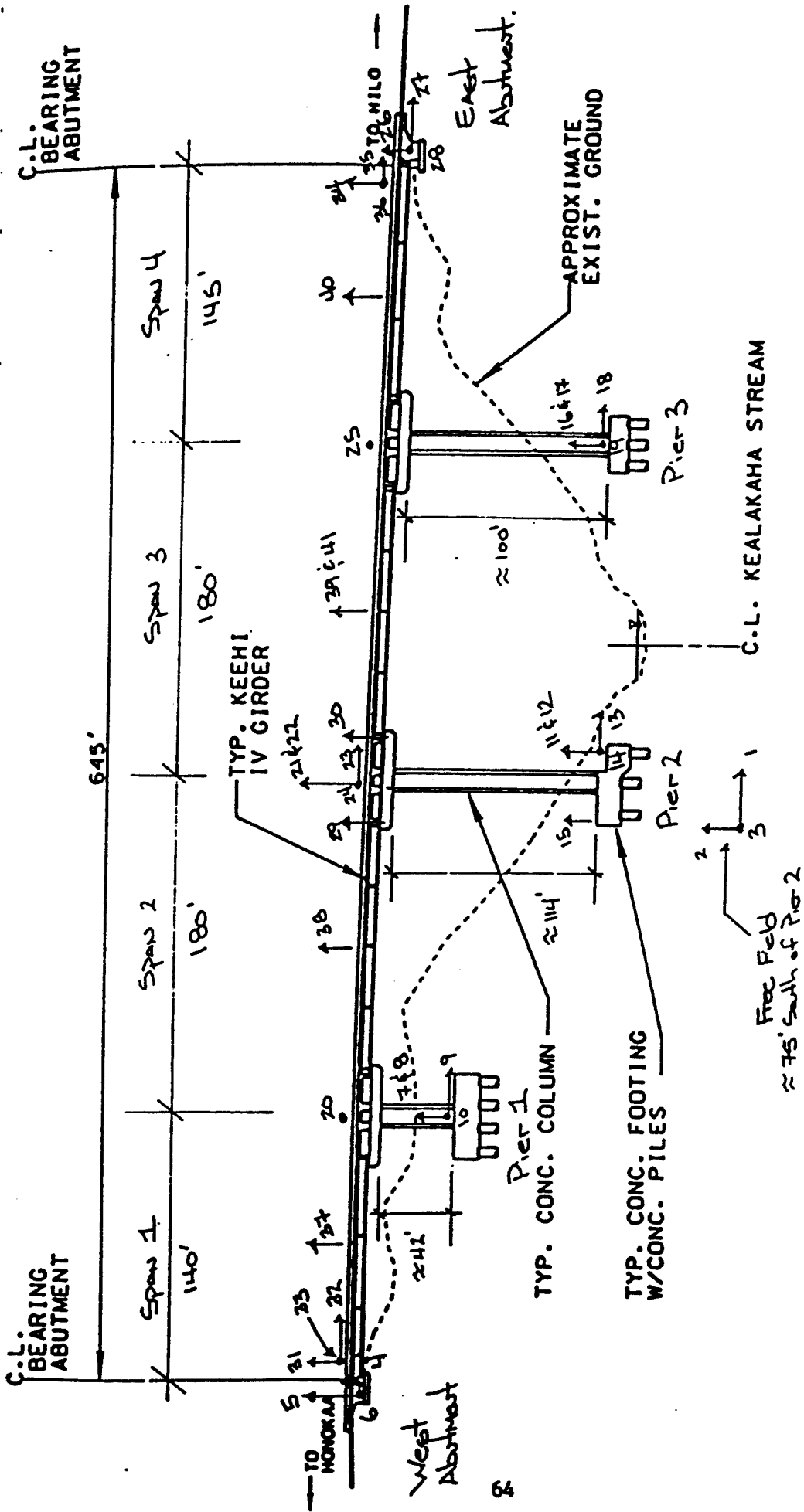

Figure 20. Kealakaha Bridge Seismic Instrument Locations (Elevation View).

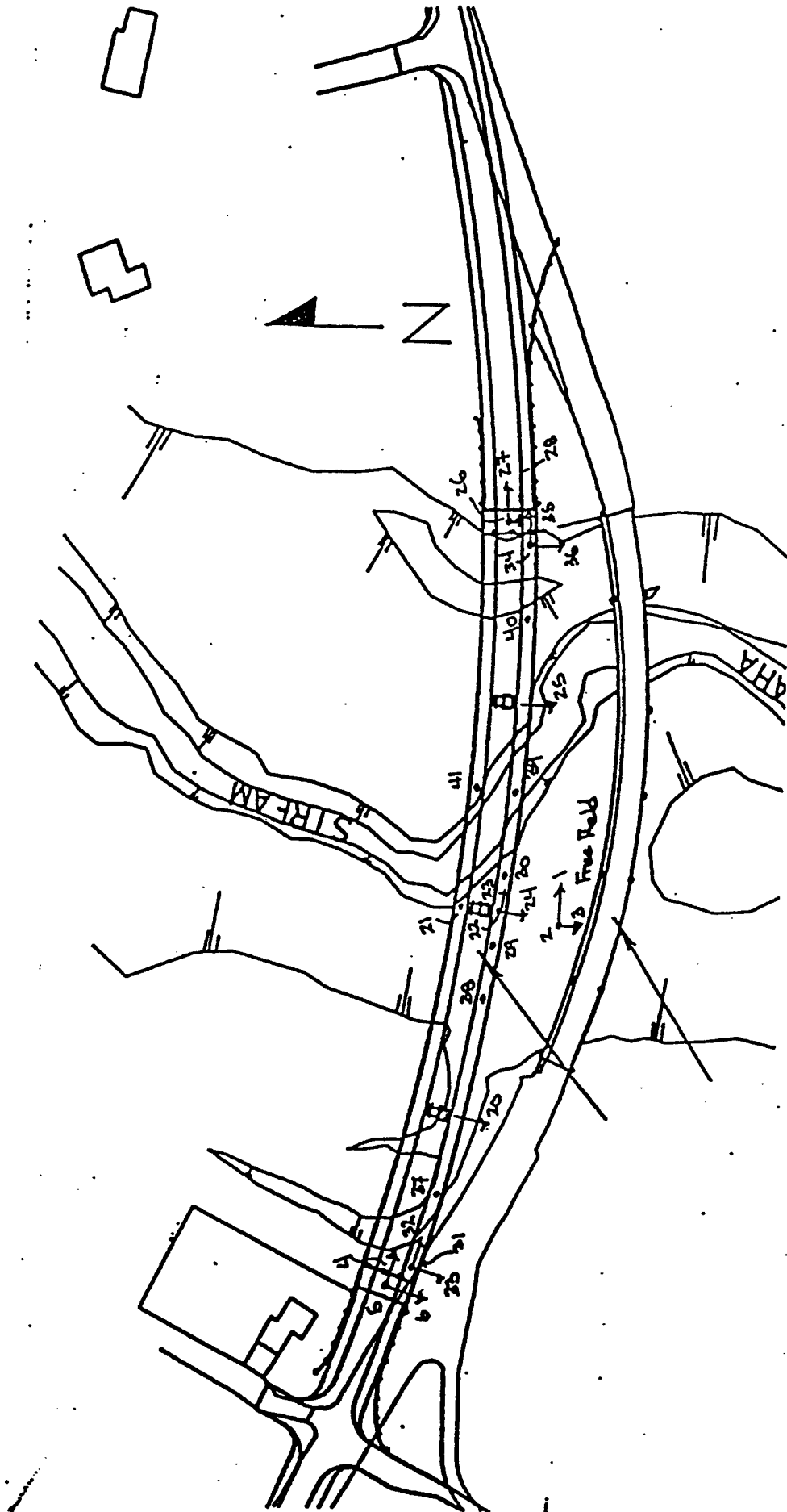

Figure 21. Kealakaha Bridge Seismic Instrument Locations (Plan View).

Supports

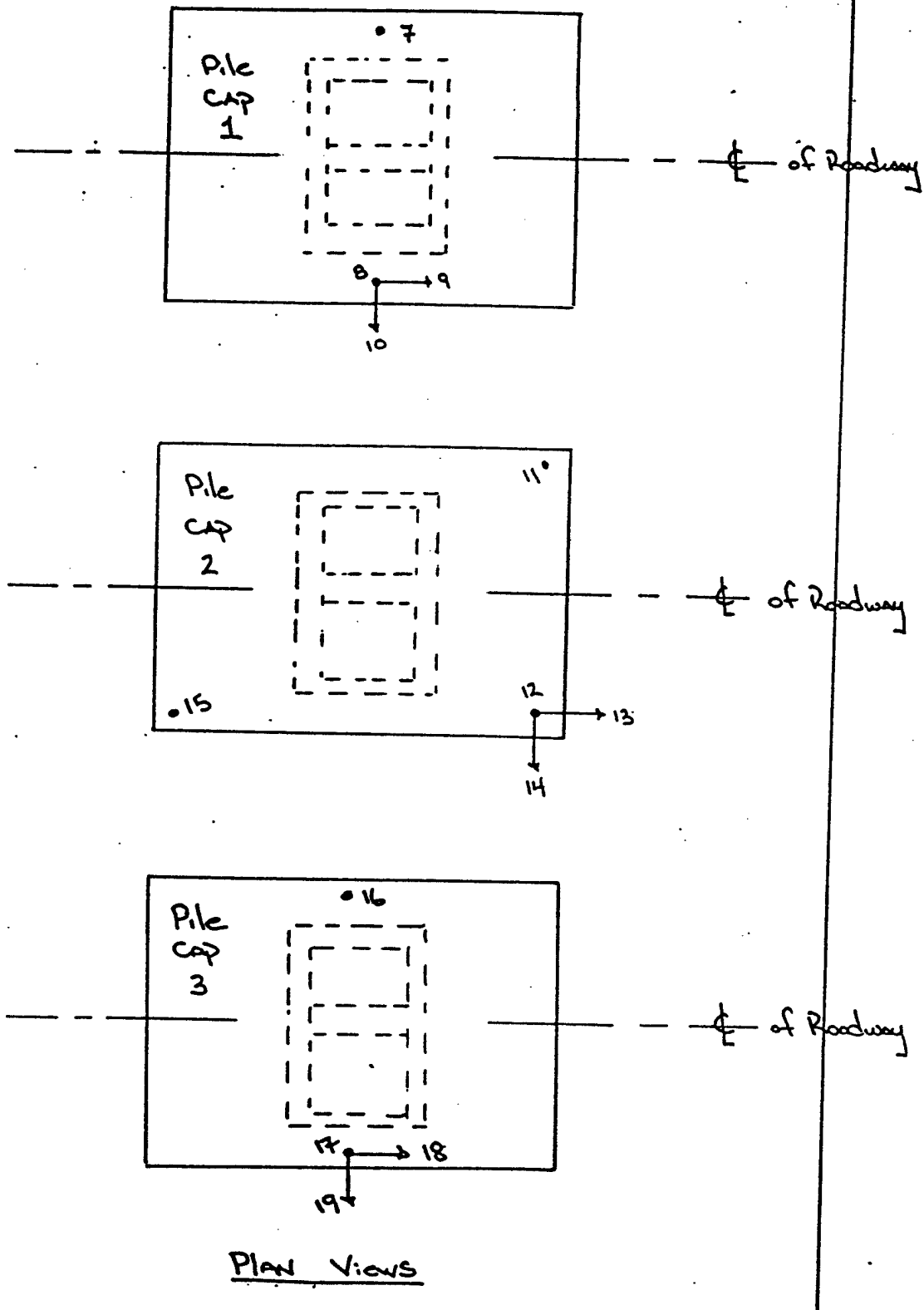

Figure 22. Kealakaha Bridge Support Seismic Instrument Locations (Plan View).

# Relative Displacement Sensors

Shows rds sensors @ East Abutment  
(Similar @ West Abutment Ch. 42 & 43)

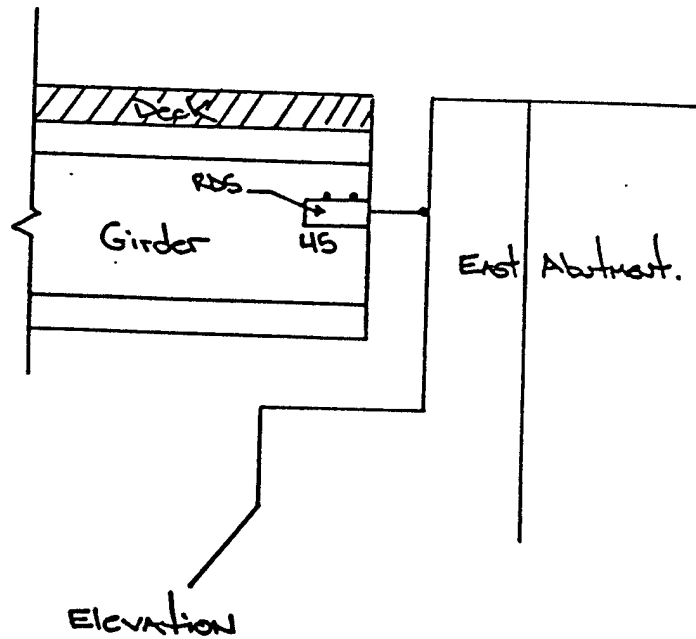
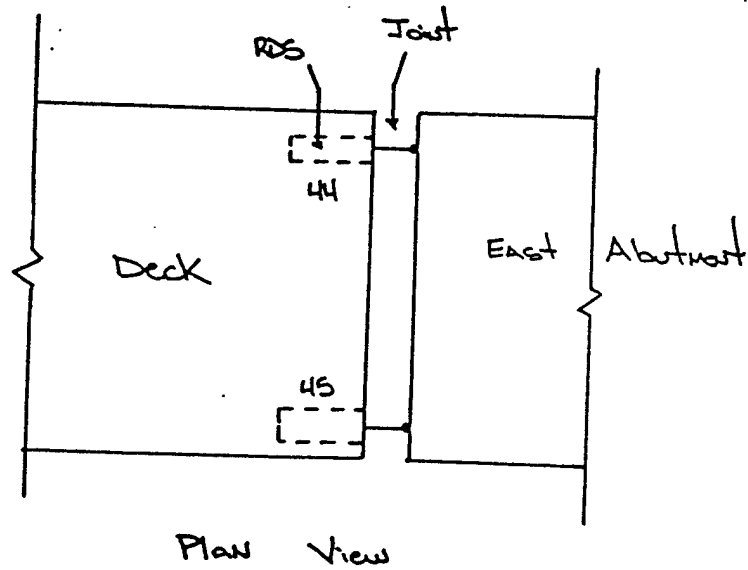

Figure 23. Kealakaha Bridge Relative Displacement Sensor (RDS) Locations.

---

## *FBA-11/-23*

---

### Low Noise Force Balance Accelerometers

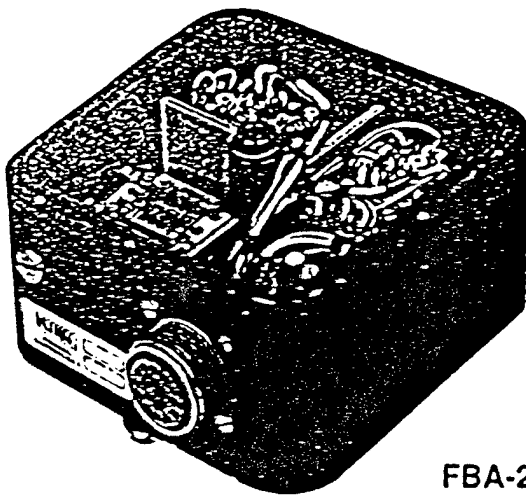

FBA-23

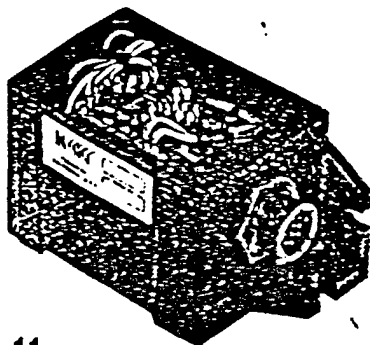

FBA-11

Kinematics' line of force balance accelerometers includes the uniaxial FBA-11 and the triaxial FBA-23. These instruments are high-sensitivity, low-frequency devices characterized by rugged construction and proven reliability. The FBA-11 and FBA-23, housed in watertight cast aluminum cases, are suitable for a variety of seismic, structural and commercial applications.

Since its creation in 1971, the design has been steadily improved, resulting in the excellent performance of today's FBA. Improvements include an accelerometer designed for downhole applications. (See separate data sheet on the FBA-23DH downhole accelerometer.)

Figure 24. Kinematics Force Balance Accelerometers.

**TERRA**  
TECHNOLOGY CORP.



Model SSA-120,  
SSA-220, SSA-320  
Servo Accelerometer

## Sapphire Line

### Features

- Bandwidth: DC to 50 Hz
- Uses Patented SA Series Force Balance Design (> 10,000 units installed)
- High Linearity, Low Hysteresis and Low Cross Axis Sensitivity
- Selectable Horizontal, Vertical or Inverted Orientation
- Single Point Mounted Enclosure provides up to  $\pm 10^\circ$  of Leveling Adjustment
- NEMA 6P rated package
- No offset drift adjustment required

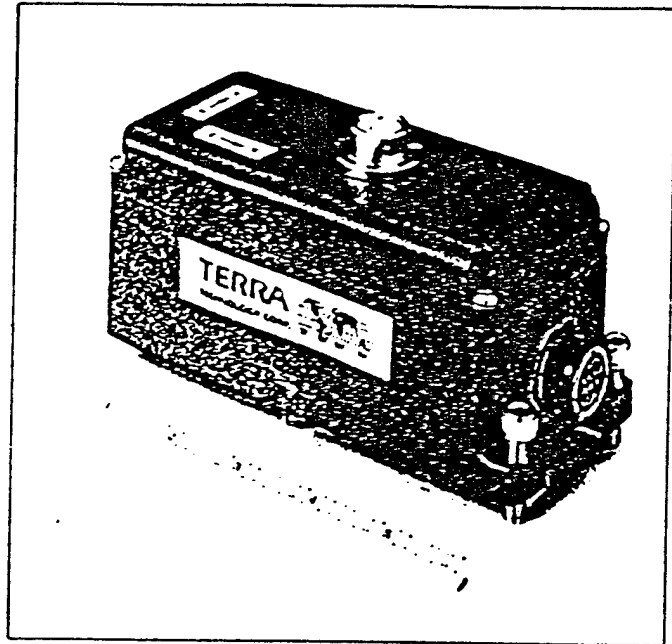

### Outline

The Terra Flex® SSA 20 Series Servo Accelerometers offer the unparalleled combination of high performance and excellent stability housed in Terra's new compact accelerometer package. The small size and convenient single bolt attachment allow the SSA 320 triaxial accelerometer to be installed in the same (or smaller) "footprint" required for competitive single axis force balance accelerometers.

The SSA 20 Series provides industry standard analog output levels of  $\pm 2.5$  volt full scale with options for  $\pm 5$  V or  $\pm 10$  V outputs. The performance of the SSA 20 Series includes exceptional linearity over a broad dynamic range, excellent bias stability and virtually no hysteresis errors or offset drift problems associated with other

force balance designs. The sensing element contained in the SSA 20 series is Terra's patented SA series design with over 10,000 units produced and installed worldwide.

The SSA 20 series electronics utilizes surface mount technology and modular design with low power consumption of 5mA per axis. Circuit cards and sensor elements are designed with connectors for easy removal and maintenance.

Typical SSA 20 Series applications include seismic monitoring applications, vibration measurements and tilt sensing in both indoor and outdoor environments. The corrosion resistant aluminum package is NEMA 6P rated which provides submersion protection in up to six feet of water.

Figure 25. Terra Technology Corp. Accelerometers.

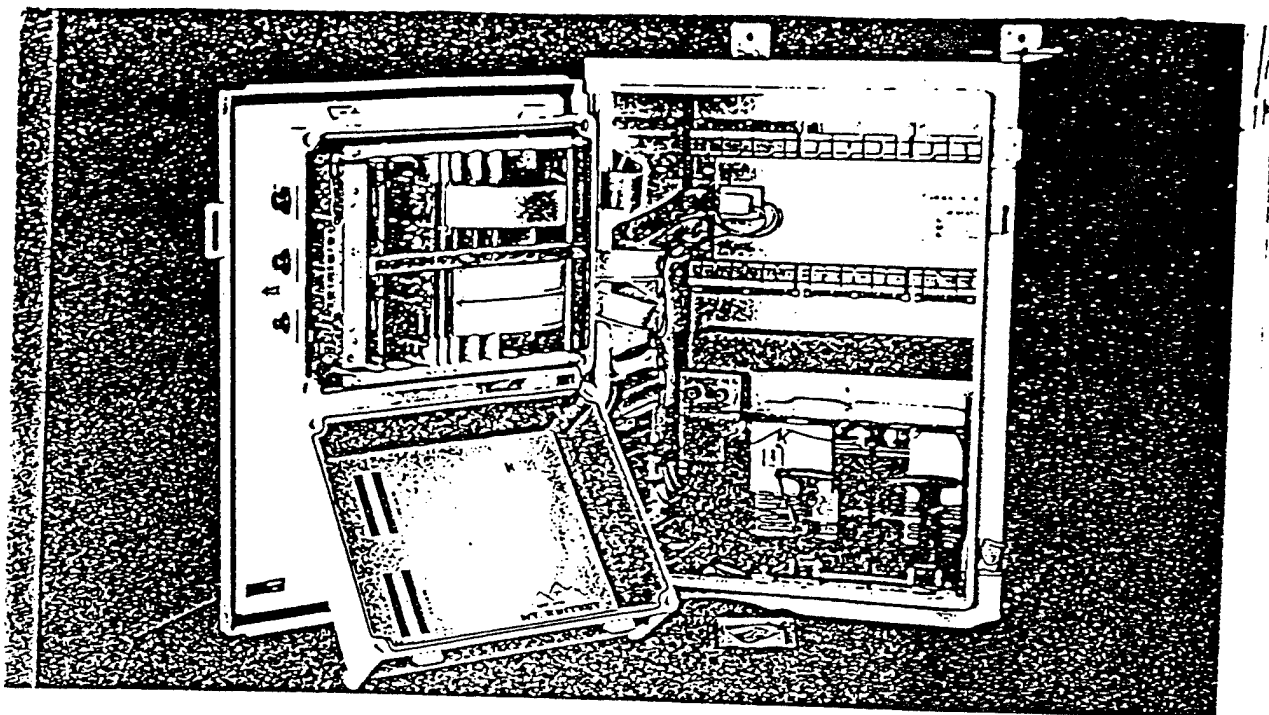

## Multi-Channel Central Recording System

### KEY BENEFITS

- ▶ 18 fully integrated recording channels, requiring only one master control board
- ▶ Recorded data storage on a single 20Mb PCMCIA card storage
- ▶ 19 bits of resolution with superior dynamic range of greater than 110dB
- ▶ Multi-tasking operating system that allows simultaneous data acquisition and interrogation
- ▶ GPS receiver supplied for synchronization to absolute time
- ▶ Zero Channel Skew through the utilization of an individual A/D Converter and Digital Signal Processing for each channel
- ▶ Remote alerting capability for both event and alarm exceedence

### INTRODUCTION

The Mt. Whitney is a multi-channel (up to 18) central recording, high dynamic range accelerograph system. This strong motion system, designed for structural monitoring applications, is the second instrument of the *Altus* family of products. The Mt. Whitney provides reliable data acquisition of the highest quality and has the added convenience and flexibility that today's technology offers. The data's extended dynamic range and bandwidth bring resolution and breadth to the data that increase its value to the structural engineer.

### MAJOR APPLICATIONS

- Structural Monitoring:
  - Buildings
  - Bridges
  - Dams
- Dense Arrays

Figure 26. Kinometrics Multi-Channel Central Recording System



#### Sapphire Line

#### Features

- Choice of 16 bit or 12 bit Recorder Module Cards
- Up to 45 Channels in a Single GNC-CR Panel
- Common Trigger, Sampling and Time Synchronization
- LED and LCD Status Indication
- On-Line Surveillance, Diagnostics and Self Checking
- CloseView Detailed Seismic Data Analysis Software
- Rackmount and Enclosure Options

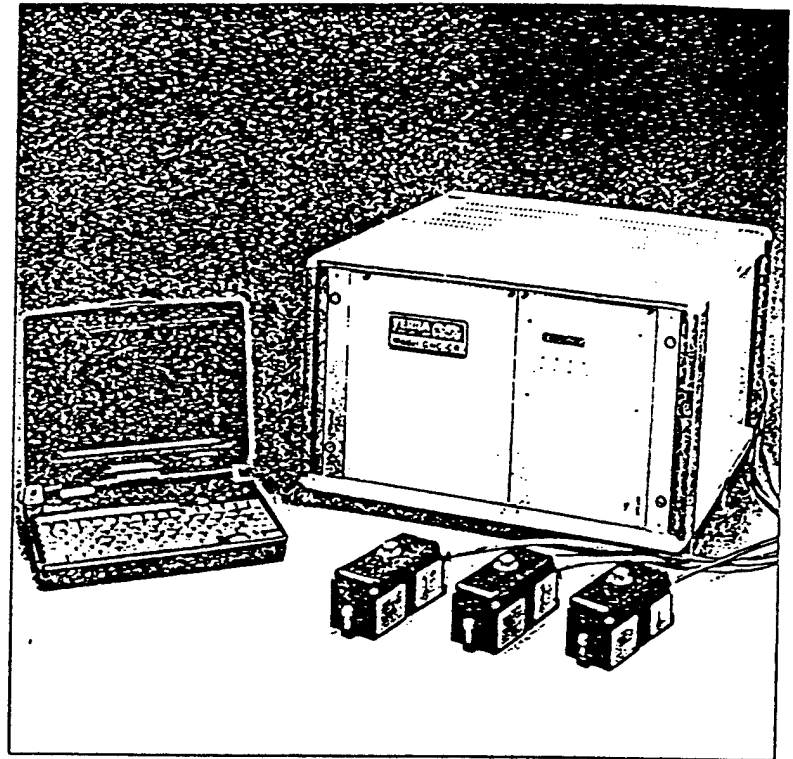

#### Outline

The GNC-CR Central Recorder is a multi-channel seismic data acquisition system including a Network Center for system communications and a choice of 16 bit or 12 bit Recorder Module Cards. Each GNC-CR panel supports up to 45 channels of three channel Recorder Module Cards.

The RMC-12 and RMC-16 Recorder Module Cards available for the GNC-CR are based on Terra's field proven 12 Bit GSR-12 and 16 Bit GSR-16 digital recorders respectively. The RMC-12 is intended for strong motion data acquisition over a 72 dB dynamic range. The RMC-16 card is recommended for applications that require a broad dynamic range (96 dB) and high precision (1 part in 65,536). Trigger modes (Threshold and/or STALTA) and trigger levels for each module channel are individually selectable.

The GNC-CR's Network Center provides on-line surveillance, common trigger, common sampling and

time synchronization. The Network Center's LCD display panel provides continuous information about the current status of the acquisition system including memory capacity, events in memory and battery voltage. The standard GNC-CR utilizes lithium battery-backed CMOS SRAM for data storage. PCMCIA Flash Memory Cards are available as an option for increased storage capacity.

All operating parameters of the GNC-CR are easily set up using a PC computer and Terra's supplied FieldView software. For detailed data analysis Terra's CloseView software includes data filters, spectral response and integration to velocity or displacement.

Packaging options include stand-alone enclosures or 19 inch rackmount. Additional interface options include lightning protection, current loop sensor interface and seismic switch outputs.

Figure 27. Terra Technology Corp. Central Recorder.