



AITI Report
88-001

UCRL 21177
PO 2193303



Prepared for
Air Force Logistics Command
AITI Project



Lawrence Livermore National Laboratory

Lockheed Aeronautical Systems Company Technical Order Transfer Tests

December 15, 1988

DTIC QUALITY INSPECTED 4

19960826 084

DISTRIBUTION STATEMENT A
Approved for public release;
Distribution Unlimited

DISCLAIMER NOTICE



THIS DOCUMENT IS BEST QUALITY AVAILABLE. THE COPY FURNISHED TO DTIC CONTAINED A SIGNIFICANT NUMBER OF PAGES WHICH DO NOT REPRODUCE LEGIBLY.

DISCLAIMER

Work performed under the auspices of the U.S. Department of Energy by Lawrence Livermore National Laboratory under contract number W-7405-ENG-48.

This document was prepared as an account of work sponsored by an agency of the United States Government. Neither the United States Government nor the University of California nor any of their employees, makes any warranty, express or implied, or assumes any legal liability or responsibility for the accuracy, completeness, or usefulness of any information, apparatus, product, or process disclosed, or represents that its use would not infringe privately owned rights. Reference herein to any specific commercial products, process, or service by trade name, trademark, manufacturer, or otherwise, does not necessarily constitute or imply its endorsement, recommendation, or favoring by the United States Government or the University of California. The views and opinions of authors expressed herein do not necessarily state or reflect those of the United States Government or the University of California, and shall not be used for advertising or product endorsement purposes.

Lockheed Aeronautical Systems Company Technical Order Transfer Tests

Prepared for
Lawrence Livermore
National Laboratory
Air Force Logistics Command
AITI Project

LLNL Contact
Peter G. Prassinos
(415) 422-4758

AFLC Contact
Mel Lammers
(513) 257-3085

Prepared by
SYSCON Corporation
3990 Sherman Street
San Diego, CA 92110

SYSCON Contact
Albert S. Howe
(619) 296-0085

December 15, 1988

Test	File Set	Document
SYSCON 88-01	LASC 88-01	Proof of Concept
SYSCON 88-02	LASC 88-02	Proof of Concept
SYSCON 88-03	LASC 88-03	Proof of Concept
SYSCON 88-04	LASC 88-04	Proof of Concept
SYSCON 88-05	LASC 88-05	Proof of Concept
SYSCON 88-06	LASC 88-06	Proof of Concept
SYSCON 88-07	LASC 88-07	Proof of Concept
SYSCON 88-09	LASC 88-09	Proof of Concept
SYSCON 88-10	LASC 88-10	Proof of Concept
SYSCON 88-12	LASC 88-12	Operational Supplement
SYSCON 88-13	LASC 88-13	Operational Supplement
SYSCON 88-14	LASC 88-14	TCTO
SYSCON 88-15	LASC 88-15	TCTO

Prepared for
Air Force Logistics Command
AITI Project



Lawrence Livermore National Laboratory

Contents

1	Executive Summary.....	1
2	File Set Preparation and Processing.....	7
3	Test Results.....	13
	3.1 Transmission Envelope.....	13
	3.2 Text Files.....	13
	3.3 IGES Files.....	15
4	Conclusions and Recommendations.....	23
5	Exhibits.....	25

1 Executive Summary

The AFLC/AITI Standards Project has been testing the Military Standard for the Automated Interchange of Technical Information, MIL-STD-1840 (the Standard). The objective of these tests has been to demonstrate the validity of the transfer protocol defined in the Standard itself and the viability of standardized formats for the transfer of technical information employed in other specifications used by the Standard. This test is the last in the series based on the original Standard. Future tests will use MIL-STD-1840A as the reference.

Lockheed Aeronautical Systems Company (LASC), Georgia Division, used its publications laboratory to prepare text and illustrations representing the data and format of several types of Air Force technical manuals. This cross section of styles and formats was prepared on two different composition systems and three illustration systems. All text was SGML-encoded, and illustrations were prepared as IGES files or as CCITT Group IV raster files. Available software was used; no software was written to meet the specific requirements of MIL-STD-1840.

Lockheed assembled the text and illustrations into 13 documents (file sets) for this test. These documents were prepared in accordance with Appendix A of the December 12, 1986, draft revision of the Standard and delivered for testing, on magnetic tape, to the ATOS laboratory facility at SYSCON Corporation, San Diego, California. Each file set consisted of a declaration file, SGML-tagged text files, and IGES or CCITT illustration files [except the Time Compliance Technical Order (TCTO)] written on magnetic tape in accordance with FIPS PUB 79 and the Standard. By agreement, each document was transmitted on a separate tape, contrary to the intent of the Standard. The quantity of data on these tapes exceeded the totality of all data previously tested.

Testing was conducted with the assistance of Lockheed personnel, and the bulk of the data was rearranged to expedite testing without compromising the test results. With the exception of some tabular material, the SGML-tagged text files were generally acceptable. Problems encountered with the composition of the text supported the need for the output specification currently being added to MIL-M-28001 (see Fig. 1).

The illustrations were delivered in both IGES (see Fig. 2) and CCITT Group IV format. Numerous deficiencies were noted, many of which prevented the production of any image. The raster illustration file header records had one consistent error, and several contained no data. The noted deficiencies were, in large part, due to the use of commercial systems that had not been modified to meet the requirements of MIL-STD-1840.

The test was a success in that it produced some new information that vendors could use for corrective action, many of the deficiencies confirmed earlier test observations, and no information was developed to suggest any modifications to the Standard. However, the goal of automated interchange of technical information was not reached in that there were enough errors in each type of data file to cause the whole transmission to be rejected in an actual transfer situation.

On the basis of this test and prior observations, it is recommended that:

1. Sending systems be provided with automated quality control tools before document-transfer testing resumes and that the same or enhanced tools be used in the actual document-transfer environment.

2. IGES be improved with respect to text fonts (see AITI Report 87-002) to meet an urgent need for transition software that conforms to MIL-D-28000 and to IGES.

Detailed conclusions and recommendations are presented in Section 4. Paired exhibits of pages from the aforementioned documents are appended to the body of this report. These pages are presented in their "as-published" and "as-transmitted and -processed" forms.

Figure 1.
A change in output specification for the receiving (ATOS) system produced an erroneous backslash (\) from correctly tagged text.

- | | |
|-------------------------------------|--|
| "As published" | (1) Ensure that cargo is prepared for air shipment in accordance with appropriate directives.
(2) Cargo inspection-contaminated items, general condition, dangerous material. |
| "As transmitted and printed" | (1) \Ensure that cargo is prepared for air shipment in accordance with appropriate directives.
(2) \Cargo inspection-contaminated items, general condition, dangerous material. |

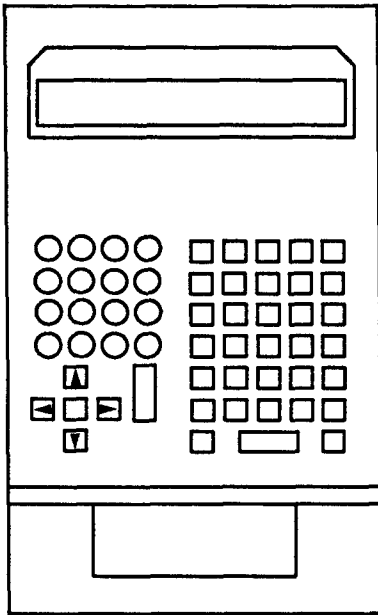

"As published"

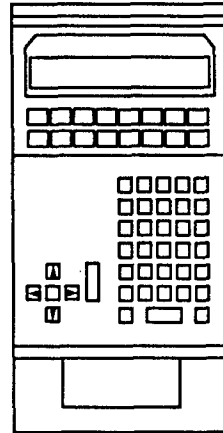

"As transmitted and processed"

Figure 2.
An image represented by an IGES file was smaller than the original and missing information.

Summary of MIL-STD-1840 testing—Lockheed—Georgia tests

Major compliance category	pass/fail		Comments
Transmission envelope			
13 files sets			
ANSI level 3 tape	pass = 13	fail = 0	
MIL-STD 1840 tape	pass = 13	fail = 0	
Declaration file	pass = 13	fail = 0	
Header records	pass = 13	fail = 0	
SGML			
6 text files			
Correct use	pass = 6	fail = 0	
No minor errors	pass = 1	fail = 5	
No tag typos	pass = 3	fail = 3	
IGES			
29 IGES files			
Version 3.0	pass = 0	fail = 2	Where two values are shown, translators from two vendors were used.
Parser/Verify	pass = 7,0	fail = 22,29	
Subset compliance	part = 12,0		
All good images	pass = 25,10	fail = 3,17	
CCITT			
32 raster files			
All good images	part = 27,0	fail = 3,2	

pass = compliant in all respects
 part = partial compliance, usable data
 fail = noncompliant, unusable data

**Explanation of Table of Summary of Compliance to
MIL-STD-1840 (11 September 1986)**

Major compliance categories	Explanation of category
Transmission envelope	The "wrapper" around the documents
ANSI level 3 tape	Does the tape comply with FIPS PUB79?
MIL-STD 1840 tape	Does the tape comply with specific MIL-STD-1840?
Declaration file	Are the document declaration files correct?
Header records	Are the header records for each data file correct?
 SGML	 SGML-tagged text files
Correct use	Do the source system personnel understand SGML?
Required tags present	Are all required tags present?
Tags keyed correctly	Were all tags keyed correctly?
 IGES	 Illustrations in IGES format
Version 3.0	Are the files (specified by MIL-STD-1840) in conformance with Version 3.0?
Parser/Verify	Did the files pass parser/verifier without serious problems?
Subset compliance	Did the files comply with MIL-STD-1840 subsets?
 IGES	 Illustrations in IGES format
All good images	Did the IGES postprocessor produce accurate images?
 CCITT	 Illustrations in CCITT raster format
All good images	Can usable images be derived from the data?

yes = compliant in all respects
part = partial compliance, usable data
no = noncompliant, unusable data
- = no graphic data in this form
* = unreadable tape

2 File-Set Preparation and Processing

Lockheed-Georgia developed three documents in their publications laboratory. These documents were developed to:

1. Evaluate the capabilities of selected authoring, graphics, and composition systems.
2. Determine optimum work methods using the selected systems.
3. Demonstrate compliance with Standard MIL-STD-1840, "Automated Interchange of Technical Information."

The documents are the "Proof of Concept" document (POC), the "Operational Supplement" (OS), and the "Time Compliance Technical Order" (TCTO). The "Proof of Concept" document consists of 10 sections representative of data from several types of USAF technical manuals. This cross section of styles and formats was chosen to provide an evaluation of some of the more complex composition tasks encountered in the preparation of technical manuals. Since the publication is a composite of pages from many different technical manuals, there is no continuity of context from section to section or, necessarily, from page to page within a section. And, many pages selected for inclusion in this publication were prepared to different military specification requirements. Therefore, to establish an overall continuity of paragraph, figure, and table numbering within this publication, the requirements of Specification MIL-M-38784A were observed.

The following describes the contents of each section and includes explanatory notes (Notes 1 and 2 apply to all sections):

Section I. Flight Manual Format (see Note 3)

Section II Organizational Maintenance Manual Format consisting of parent -2 Series Manual, Fault Isolation Manual, and Job Guide Manual formats (see Note 4)

Section III Structural Repair and Related Manuals Format consisting of Structural Repair, Pylon Overhaul, Cowl Door Overhaul, Battle Damage Repair, Corrosion Control, and Nondestructive Inspection Manual formats.

Section IV Illustrated Parts Breakdown Format

Section V Basic Weight Checklist and Loading Data Format

Section VI Workcard Format (see Note 5)

Section VII List of Applicable Publications and Tape Manual Format

Section VIII Support Equipment and Component Manuals Format

Section IX Cargo Loading Manual Format

Section X Engine Buildup Manual Format

NOTE 1: The SGML tags listed in ATOS Technical Report No. F42650-85-C3410 were used throughout this publication (see "References" paragraph below). In addition, system-specific processing commands were used to compose tabular data in the reference (paper) copy of this publication. These processing commands were needed to produce the style and format of the original tabular material.

The SGML table tags given in the ATOS Technical Report did not provide for such items as drawing horizontal and vertical line rules, setting column and gutter widths, aligning and justifying text within rows and columns, spanning columns with text, adjusting leading between row entries, and creating landscaped tables.

Landscaped tables were created using a "content=r" SGML tag attribute not given in the ATOS Technical Report. The ATOS Technical Report also did not list SGML tags for mathematical symbols. Mathematical symbols were created in the reference copy, using SGML tags implemented by Datalogics. All system-specific processing commands and nonconforming SGML (as noted here) tags and attributes were deleted from the magnetic tape version of this publication to conform to Standard MIL-STD-1840 requirements.

NOTE 2: Datalogics Composition software does not currently accept the input of CCITT Group IV graphics. The pages on which those graphics appeared have been annotated in the reference copy, and graphics have been provided on the magnetic media.

NOTE 3: USAF flight manuals do not contain numbered paragraphs; however, the paragraphs have been numbered here to maintain continuity within this publication and to aid in evaluating the automatic numbering capabilities of the selected composition systems.

NOTE 4: The Job Guide Manual format was created using a combination of SGML table tags and system-specific processing commands. The referenced ATOS Technical Report does not list specific SGML tags for creating Job Guide Manual formats.

NOTE 5: The Workcard format was created using a combination of SGML table tags and system-specific processing commands. The referenced ATOS Technical Report does not list specific SGML tags for creating Workcard formats.

REFERENCES. This document was prepared in accordance with:

(1) The SGML tagging scheme outlined in Technical Report No. F42650-85-C3410, Text Standard Generalized Markup Language, Automated Technical Order System (ATOS), ATOS Project Office (OO-ALC/MMED-3) Hill AFB, Utah, dated 23 May 1986.

(2) Specification MIL-M-38784A, Manuals, Technical: General Style and Format Requirements, dated 1 January 1975.

(3) Standard MIL-STD-1840, Automated Interchange of Technical Information, draft revision dated 12 December 1986.

The text of the three Lockheed documents—"Proof of Concept" document, "Operational Supplement," and "Time Compliance Technical Order" (TCTO)—was composed on two composition systems (Datalogics and Xyvision), and the illustrations were prepared on three illustration systems (Auto-trol, Intergraph, and Qubix). Illustration files were transmitted to the composition system via Page-One, CalComp 925, or Interleaf software protocols to test the quality resulting in the use of each format. Various combinations of these text and illustration files were combined to produce the 13 MIL-STD-1840 documents (file sets) reported here. Table 2.1 gives the source for text and illustration files, as well as the illustration transmission format, of each file set.

Table 2.1. List of files sets delivered by LASC for MIL-STD-1840 testing

File set No.	Volume name	Composition system	Illustration system	Conversion format	MIL-STD-1840 format
<u>Proof of Concept Document</u>					
LASC-88-01	LG0101	Datalogics	Auto-trol	Page-One	CCITT
LASC-88-02	LG0101	Datalogics	Auto-trol	CalComp 925	CCITT
LASC-88-03	LG0101	Datalogics	Intergraph	CalComp 925	CCITT
LASC-88-04	LG0101	Datalogics	Qubix	Interleaf	CCITT
LASC-88-05	LG0101	Datalogics	Qubix	CalComp 925	CCITT
LASC-88-06	LG0101	Datalogics	Auto-trol	(None)	IGES
LASC-88-07	LG0101	Datalogics	Intergraph	(None)	IGES
LASC-88-08	LG0101	Datalogics	Qubix	(None)	IGES *
LASC-88-09	LG0101	Xyvision	Auto-trol	(None)	IGES
LASC-88-10	LG0101	Xyvision	Intergraph	(None)	IGES
LASC-88-11	LG0101	Xyvision	Qubix	(None)	IGES *
<u>Operational Supplement</u>					
LASC-88-12	LG0101	Datalogics	Auto-trol	(None)	IGES
LASC-88-13	LG0101	Xyvision	Intergraph	(None)	IGES
<u>TCTO</u>					
LASC-88-14	LG0101	(No art)	(None)	(None)	
LASC-88-15	LG0101	(No art)	(None)	(None)	

* File sets 8 and 11 were not delivered because Qubix did not participate in the IGES portion of the testing.

NOTE: File sets 6, 7, 9, and 10 also contain CCITT illustrations for art that had not been vectorized. File sets 9 and 10 have no file for Figure 2-5. The source of the art was in III v-bit format, which is not currently accepted by Xyvision.

Each of the 13 documents was transmitted on a separate tape, a departure from desirable practice as described in the Standard. This variation was agreed to in advance of the testing.

The file sets, on magnetic tape, were delivered to the ATOS laboratory facility at SYSCON Corporation, San Diego, California, for testing. The initial tape processing and most of the testing were performed on a VAX. An Auto-trol AGT 70 was used to convert the IGES files to a CAD format and, subsequently, to a plotter format. The plotter files were then converted to a form acceptable to the QMS laser printer. Text hardcopy was output on the same printer.

The file sets were processed in the ATOS laboratory, using a combination of specially built and commercially available software. Each file set consisted of a declaration file, SGML-tagged text files, and illustration files except for the TCTO. With the advice and assistance of Lockheed personnel, the text and illustration files from the 13 documents were rearranged so that all files containing data with the same encoding format (SGML, IGES, CCITT) were tested as a group. Test details are presented with the analysis for each data type.

The file sets were submitted and accepted with the understanding that they deviated in some respects from the requirements of MIL-STD-1840. Because of the deviations, several adjustments to the test procedures and software had to be implemented ad hoc. Extensive communication with Lockheed before and during the test period proved invaluable.

3 Test Results

The test results presented here are, in most cases, in summarized form. Detailed test results and detailed procedures for recreating the test are available to interested parties wishing to pursue data analysis and troubleshooting.

3.1 Transmission Envelope

The transmission envelope, including the file header records, was in good enough condition to permit loading of the data. Although, there was a consistent error in header record 11 of each of the raster files, the error did not impede the test. Header record 11 associates text file references to illustrations with external file names.

3.2 Text Files

The 13 documents consisted of three basic text components produced by means of two different text processing systems. The three text components were: a composite Technical Order, dubbed the Proof of Concept document (POC), an Operational Supplement (OS), and a Time Compliance Technical Order (TCTO). The permutations produced six unique (for test purposes) text files. Each document number was coded with a "D" or "X" to indicate the hardware/software system employed to compose the page images—e.g., POCD indicates the document was produced on the Datalogics system, and POCX indicates that a Xyvision system was used.

Preparation of the SGML-tagged text files showed a good practical understanding of the use of SGML. Major difficulties with tabular material were again encountered, as noted in previous reports. In some instances, table-tag problems were compounded by processing instructions (native markup codes) that were applied to achieve an acceptable image at the source system and then removed prior to transmission, with the result that the tables could not be composed at the destination system. Hopefully this problem with tagging tabular material will be alleviated by the advent of MIL-M-28001. Had the transmission taken place in a production environment, the errors in the files would have been sufficient grounds to reject the whole lot (transmission).

Exhibits 1-4 present the preface from the POCD composite technical order. The odd-numbered exhibits present the "as-published" images, and the even-numbered exhibits present the "as-transmitted and -processed" images. This convention is maintained throughout the exhibits for the analysis of SGML-tagged text files. Note that many differences are due to the processing of all output to the same output specification (MIL-D-38784A) even though the "as-published" formats varied among document types.

The differences in appearance between the odd- and even-numbered exhibits are due to some basic deficiencies of the document-type definition (an application of SGML) for this test program. The SGML application used for this test was of 1986 vintage and, though generally adequate, did not provide a complete "package" to the source and destination systems. By definition, SGML applications do not specify imaging details. The missing element was a rigorous definition of the imaging action to be taken for the context in which each SGML tag was found. Efforts are under way to make MIL-M-28001 complete with respect to conventions for imaging SGML-tagged text files.

Exhibits 5-8 present the preface from the POCX composite technical order. A comparison of Exhibits 5 and 1 reveals a difference in the allocation of text to pages, but less variation in overall appearance between "as-published" versions of each document than between "as-published" and "as-transmitted and -processed" versions. Exhibit 6 reveals a minor tagging error (note the backslash following each section number in the table).

A comparison of Exhibits 4 and 8 shows that some differences in tagging must have occurred. See Note 3, Exhibit 7.

The occurrence of a seemingly irrelevant backslash throughout the pages composed on the ATOS system is not wholly the result of errors in tagging. The configuration of the table-driven composition software on the ATOS system used to produce the images for this report has changed since the document-type definition (DTD) used to construct the text files for this test was released. In other words, what as once valid is no longer valid with respect to ATOS. Now, as then, there is no specification for imaging SGML tags. This deficiency is compounded by the problem of maintaining configuration control of DTDs and imaging definitions. The effects of the two problems are not easily distinguished in the composed images.

Exhibits 9-12 present a maintenance parts list (MPL) table. The degree of success in replicating the "as-published" images from the POCD and POCX documents cannot be attributed entirely to the use of SGML tags, however, since many other MPLs could not be composed because the number of columns varied from a predetermined format defined in the

ATOS system. Rather, much of it can be attributed to the fact that the table presented follows a USAF convention. A closer examination of the table reveals several variances. Bearing in mind that all four exhibits present the "same" table, note that the number of row entries for Exhibits 9 and 10 varies by one while that for Exhibits 11 and 12 varies by four. Although type size could account for the difference between Exhibits 11 and 12, the type appears to be the same size in Exhibits 9 and 10. Column widths also vary noticeably. Nevertheless, these exhibits represent the most successful imaging of tabular text in this test. The <page . . .> tag has not yet been implemented in ATOS or any other system. Page integrity is, therefore, a happenstance in this case.

Exhibits 13–16 present the first page of a section. The occurrence of the backslash mentioned previously is prominent in Exhibits 14 and 16. In this case, the backslash is purely a configuration control issue, not a tagging error. Page integrity is not achieved, but the images are encouragingly close in appearance.

Exhibits 17–20 present the first page of the composite TCTO. The footer, "This technical order is required . . ." is missing in Exhibit 18 because the required tag (<ftnotice>) is missing. How the text of this footnote was put into the image shown in Exhibit 17 is not clear since page integrity, in this case, is not even approximate.

Exhibits 21–25 present the first page of the composite OS. Except for the border consisting of the letters "OS," which is added automatically by the ATOS composition software, these exhibits come closest to replicating a transmitted page. The misplacement of the header words "PURPOSE" and "INSTRUCTIONS" in Exhibit 22 is a tagging error.

3.3 IGES Files

Illustrations for the POC and OS were produced in IGES format through IGES preprocessors. These preprocessors came from two different vendors and generated four unique (for test purposes) data sets. The POC IGES file sets consisted of 29 files each, and the OS sets had one file each.

The major points of nonconformance or failure in the IGES files are listed below.

1. Neither preprocessor claimed to conform with Version 3.0 of the IGES. To date, none of the files received has made this claim.
2. Only one preprocessor achieved MIL-STD-1840 subset conformance. However, the conformance appears to be accidental rather than by design.

3. None of the IGES or previously submitted files conformed to the Standard, which specifies that all entities used be assigned to level zero.
4. The postprocessor could not convert many entities. While the font specification for these entities, most of which were general notes, was rejected because of the limitations of the available IGES postprocessor, the ASCII string and position were accepted. Entity type 402, with a valid nonobsolete form value, was also ignored with the statement that no conversion was available for that entity number.
5. Several files failed completely in postprocessing translation, and no data were obtained.
6. The files from one CAD vendor came from two different releases of CAD software, causing that vendor's IGES postprocessor to generate different entities.
7. Several files could not be processed because directory entries were formatted incorrectly. It is very unusual for software to generate inconsistently formatted records.
8. The postprocessor rejected several files for "parameter data out of sequence." The exact source of the problem cannot be determined here.

Several illustrations were scanned and then processed through a raster-to-vector converter and submitted for test without manual cleanup at a CAD workstation. Exhibit 40 is a mild example. The visual fidelity of the illustrations was far below technical publication quality and qualitatively too poor for test purposes. The effect of no cleanup created lingering uncertainty about the visual accuracy of the images although no divergence from the "originals" was immediately detectable

In a large number of the illustrations, no line weights were assigned to any of the "visible" entities. A blank or zero line weight is an error according to the IGES. When hardcopy of these illustrations was produced, the line weight was defaulted to the lightest weight available on the output device. The resulting images were clear, but, because of the minimal line weights, not acceptable to the Lockheed personnel who reviewed them.

Uncertainty with respect to visual accuracy is the psychological residue or these problems. With earlier test experience generally limited to simple

diagrams and line drawings, it appeared that visual comparison of “as-published” and “as-received and -reproduced” images was an adequate check on visual accuracy. On reflection, this assumption is probably in error.

The convention of presenting “as-published” images in odd-numbered exhibits and “as-transmitted and -processed” images in even-numbered exhibits is, with the exception of Exhibits 27 and 28, followed in Exhibits 25–26.

Exhibits 25–28 present Figure 2-14 from the composite technical order. Exhibit 25 is the POCD “as-published” image. Exhibits 26 and 27 were produced from IGES files transmitted for the POCD and POCX documents, respectively. Exhibit 28 was produced from the transmitted CCITT Group IV file, which, in turn, was produced from the same source as the IGES file for Exhibit 26. At first glance, the illustrations appear to be the same; however, closer examination reveals that Exhibit 26 is missing a number of elements. Reference to Exhibit 25 shows that the center panel has a 4-by-4 matrix of circles to the left of an imaginary vertical midline. In Exhibit 26, these elements are missing altogether. Continued comparison reveals that the toggle switches shown in the left and right panels of Exhibits 25, 27, and 28 are incompletely reproduced in Exhibit 26. Again, in Exhibit 26, the semicircles in the right panel are missing, as are many small vectors used to join the fillets. The center panel image also shows that many fillet closing vectors are missing. In this case, the IGES pre-processor is suspect.

The IGES file for Exhibit 27 was produced by software from a vendor other than the one who produced Exhibits 25 and 26. While the image is complete, there is some wavering in what are supposedly straight lines in the center panel’s upper two rows of rectangles.

Exhibit 28, produced from a raster image, has been included for comparison. Overall, this image is closer to Exhibit 25 than the transmitted and processed images in Exhibits 26 and 27. Refer to Section 3.4 for a discussion of how the raster images were reproduced.

Exhibits 29–32 present Figure 2-8 from the POC. The IGES file transmitted to represent Figure 2-8 was not derived from the file that produced the “as-published” image for the Datalogics composition. Refer to the top left of Exhibit 29, where the flow begins. The phrase here says “FROM SHT 1.” The same position on Exhibit 30 shows the phrase “FROM SHEET 1” while Exhibits 31 and 32 use the phrase “FROM SHT 1.” Block 28 (a hexagon) at lower right in Exhibit 29 contains the word “Dismount” while the word “Disconnect” appears in the same location in Exhibit 30. The text in Exhibit 30 is fully justified, but left-justified in Exhibit 29.

Transmission of the wrong file will be difficult to detect in a production situation, where receiving inspection is expected to be cursory or, in any event, nowhere as intense as in this test.

The IGES file that generated Exhibit 30 was stroked (ASCII text converted to vectors), but there were still difficulties with correctly imaging the text. While many locations in Exhibit 29 show a plus sign set very directly over a minus sign where tolerances are given, the minus sign is shortened almost to the size of a period in Exhibit 30. The file-size penalty incurred by converting ASCII characters to vectors did not pay off in this case either since Exhibit 30 (the stroked file) required 5468 disk storage blocks. Exhibits 33-36 present Figure 10-1. The consistency in the appearance of the figure (or image) from exhibit to exhibit was remarkable. Additionally, it was observed, although the two "as-transmitted and -processed" images (Exhibits 34 and 36) of the figure were of identical size, that the "as-published" images differed in size from IGES files. If the figure were transferred via MIL-STD-1840 in a production situation, an illustrator would have to load the IGES file into a workstation and rescale it to fit the allotted space. Intervention of this kind is very costly compared to the case where no intervention is needed.

In summary, the tests of the IGES files were a success in that they uncovered several new "failures" and confirmed many previously noted errors. If transmission had taken place in a production environment, the errors in the IGES files would have been sufficient grounds to reject the whole lot (transmission). It is clear at this stage of the test program that the implementation of the IGES in industry is not yet sufficiently robust for AITI purposes.

Tables 3-1 and 3-2 that follow summarize the data generated by the IGES data analysis parser and verify software. Included in the tables is a go/no-go column showing the result of IGES postprocessing.

Table 3.1. IGES file test worksheet

Test subdirectory: IGES1 CAD software version: S5K, v.5 or v.6
 IGES preprocessor: Auto-trol S5KPRE, v4.0
 IGES postprocessor: Auto-trol, S5KPOST v4.0 (123-13485-004 rev A)

File No.	Artboard number	v	IDA output		Ent. rej.	Image OK?		
			IDA parser Errors	IDA verify Warnings				
1	ART018	6	2,648a	194b	0	1a	0	yes
2	DELTA2	5	0	3c,d	0	3b	0	yes
3	ART036	6	1,495a	0	0	0	0	yes
4	ART038	6	119a	0	1c	2a,d	0	yes
5	ART039	6	4,621a	1b	1c	1a	0	yes
6	DELTA2	5	0	2c	0	2b	0	yes
7	DELTA3	5	0	2c	0	2,070e	0	yes
8	ART044	5	22e	2c	0	1a	0	yes
9	ART047	6	10,771a	0	0	11d	0	yes
10	ART048	5	95e	2c	0	2b	0	yes
11	ART055	5	0	2c	0	2,093b,e	0	yes
12	CIRCLE	5	106e	2c	0	2b	0	yes
13	STAR	5	344e	2c	0	2b	0	yes
14	ART064	6	8,578a	0	0	1a	0	yes
15	ART066	6	2,561a,f	0	236	1a	f118	no
16	ART079	6	3,644a	0	27c,f	2a,d	8	no
17	ART081	5	3e	2c	0	1,209b,e	0	yes
18	ART083	5	0	2c	0	504e	0	yes
19	ART104	6	784a	0	0	1a	0	yes
20	ART110	6	5,991a	0	0	1a	0	yes
21	ART111	6	2,122a	0	1c	1a	0	yes
22	ART113	6	432a	0	0	0	0	yes
23	ART114	5	0	2a	0	2b	0	yes
24	ART119	6	bad file					no
25	ART139	6	7,889a	13,476b	0	8d	0	yes
26	ART140	5	0	2c	0	1,428b,e	0	yes
27	ART141	6	6,298a	27,701b	0	10c	1a	yes
28	ART142	6	8,877a	39,762b	10c	1a	0	yes
29	ART035	6	1,573a	0	10c	1a	0	yes

IDA Parser notes

- a Line font = 0 in directory entry'
- b Too many digits in parameter
- c Number of line weights not between 0, 32,768
Maximum line thickness = 0
- d Maximum coordinate value in data is to be 0
- e Real constant without leading digit
- f Color has undefined positive value

IDA Verify notes

- a Entity label not right-justified
- b Same as Parser note C
- c Radii not equal
- d Zero length line
- e Line width exceeds maximum
- f Start/end point off conic

Table 3.2. IGES file test worksheet.

Test subdirectory: IGES2

IGES preprocessor: A5 = Auto-trol S5K, v5.0 for IGES v2.0

I = Intergraph 8.8.4 for IGES v2.0

IGES postprocessor: Auto-trol, R 4.0 (123-13485-004 rev A)

File No.	Artboard number	v	IDA output		IDA verify	Ent.		Image rej.	OK?
			IDA parser Errors	Warnings		Errors	Warnings		
1	ART018	I	761a	791d,g,h,i	0	3a,g,h	nc		
2	DELTA1	A5	0	3c,d	0	3b,h	0	ok	
3	ART036	I	1,831a	1,834d,g,i	0	3a,g,h	0	ok	
4	ART038	I	blew up		no data		nc		
5	ART039	I	101a	242d,g,h,i	8c,i	3a,g,h	nc		
6	DELTA2	A5	0	2c	0	2b	0	ok	
7	DELTA3	A5	0	2c	0	2b	0	ok	
8	ART044	I	bad file				nc		
9	ART047	I	3,279a,f	2,808g,h,j	26c,i	60a,d,g,h	0	no	
10	ART048	I	2,733a	2,736d,g,i	0	3a,g,h	0	ok*	
11	ART055	I	1,722a	1,840d,g,i	0	3a,g,h	0	ok	
12	CIRCLE	A5	106e	2c	0	2b	0	ok	
13	STAR	A5	344e	2c	0	2b	0	ok	
14	ART064	I	1,958a,f	2,107d,g,i	22c	77a,g,h,k	50	no	
15	ART066	I	9,686a,f	7,356d,g,i	27c,k	61a,d,g,h,k	118	no	
16	ART079	I	1,756a,f	5,071d,g,i	27c	67a,d,g,h,k	22	no	
17	ART081	I	1,381a	1,146d,g,h,i	8i	3a,g,h	nc		
18	ART083	I	512a	471d,g,h,i	2i	3a,g,h	nc		
19	ART104	I	365a	164d,g,i	2c	3a,g,h	4	no	
20	ART110	I	6,681a,f,j,k	3,736d,g,i	10c	11a,d,g,h	2	no	
21	ART111	I	26a,f	72d,g,i	4c	3a,g,h	6	no	
22	ART113	I	432a	435d,g,i	0	3a,g,h	0	ok	
23	ART114	I	5,389a	5,392d,g,i	0	3a,g,h	0	ok	
24	ART119	I	803a,f	5,638d,g,i	blew up		48	no	
25	ART139	I	234f	2,096d,g,i184c,l,m,n	123a,d,g,h,o		9	no	
26	ART140	I	17a	1,179d,g,h,i	0	3a,g,h	nc		
27	ART141	I	2a	279d,g,i	4p	3a,g,h	10	no	
28	ART142	I	42a	583d,g,i	5p	3a,g,h	193	no	
29	ART035	I	1,583a	1,555d,g,i	4f	3a,g,h	0	ok	

(Table 3.2. Notes - continued on page 21.)

IDA Parser notes

- a Line font = 0 in directory entry
- b Too many digits in parameter
- c Number of line weights not between 0, 32,768
Maximum line thickness = 0
- d Maximum coordinate value in data is to be 0
- e Real constant without leading digit
- f Color has undefined positive value
- g Status fields not one number
- h Data not an integer
- i Maximum line thickness spec. = 0
- j Parameter data overflow
- k Character string differs

- * As good as the original, but not
technical publications quality

nc = No conversion

IDA Verify notes

- a Entity label not right-justified
- b Same as Parser note C
- c Radii not equal
- d Zero length line
- e Line width exceeds maximum
- f Start/end point off conic
- g Maximum line thickness spec. =
- h Maximum coord. value in data is
- i Invalid font reference
- j Same as Parser note q
- k Conic not in standard orientation
- l Zero radius circle
- m Determinant not +1
- n Scale factor too small
- o Defining vector error
- p No entity instanced

3.4 CCITT Files

The illustrations in CCITT Group IV format were produced through five different combinations of software. Only the last element in each triplet of software packages generated CCITT data. The first and second software packages created the illustration and generated a plot file respectively. The letter code in parentheses following the name of the second software package indicates the vendor that implemented the data format. All the illustrations were for the POC document. The combinations were:

- a. Auto-trol S5000 to Auto-trol Page One (A) to Datalogics.
- b. Auto-trol S5000 to CalComp 925 (I) to Datalogics.
- c. Intergraph to CalComp 925 (I) to Datalogics.
- d. Qubix to Interleaf format to Datalogics.
- e. Quibix to CalComp 925 (Q) to Datalogics.

The errors encountered demonstrated that many of the files were not in conformance with the Standard. Files in groups 2–5 often contained an extraneous record at the beginning of the second tape block, or logical record 17. Although this record is supposed to be CCITT data, the extra record was not CCITT data, but a kind of header indicating the scanning density and image dimensions in pixels. The vendor of the software package has been apprised of the problem and supplied with test data for corrective action. Why none of the images in the first group—(a) above—had this error cannot be determined.

After a fix was applied to remove the extra record from the CCITT data, the files were reprocessed. Still, a few files would not produce an image. The tests were conducted by comparing the input data from one vendor (Vendor A) against the data processing of another (Vendor B). No neutral certified process is available for testing a CCITT image.

Several files were noted (in header record 12) as being empty. Although the absence of the data did not harm the test process, it does raise a question about the adequacy of the generating process for production purposes.

Exhibits 37-40 are provided to display the appearance of illustrations in raster form. Exhibit 37 is an image produced from an IGES file, and Exhibit 38 is the same illustration transmitted in raster form. Exhibit 39 is the raster version of the illustration presented in Exhibits 33-36. Exhibit 40 is the raster version of an illustration that was scanned and vectorized, but not "cleaned up" on a CAD workstation.

All the raster files were scanned and transmitted at a density of 200 pels. The hardcopy images were produced, by interpolation, on a 300-pel print engine. Since no hardcopy device with a resolution of 200 pels is available at this test site, it cannot be determined whether the gestalt of the images would differ significantly.

In those cases where an image could be produced, the results seemed faithful to the originals. However, the 200-dpi scanning density did not seem to provide an image of technical publications quality.

If the transmission had taken place in a production environment, the errors in the files would have been sufficient grounds to reject the whole lot (transmission).

4 Conclusions and Recommendations

The policy established at the beginning of this test program—to use only documents that have been accepted for distribution or reference documents—should be followed closely. The high quality and self-consistency of these documents provide more productive test material than other “unofficial” test data.

The document declaration and header records defined in MIL-STD-1840 served their intended purpose well. There were several cases where “empty” files were transmitted and at least one case where the wrong file was transmitted.

Most of the test results with text files underscored the need for an output specification (OS), and an effort is currently under way to complete an OS as Appendix C to MIL-M-28001. The DTD supplied to the source system was out of step with the DTD in use at the destination system, thereby producing some obvious errors. To prevent further occurrences, test planning should note that the standards and specifications upon which MIL-STD-1840 relies can be expected to go through a rapid cycle of changes for several years.

The IGES translators encountered during this and other tests do not conform to version 3.0 of the specification. Nonconformance with respect to line weights has emerged as a consistent, widespread problem. In at least one case, the preprocessor did not generate all the entities necessary to preserve visual accuracy. In other cases, either the whole IGES file was rejected or some entities could not be translated by the postprocessor.

The illustrations transmitted in CCITT Group IV format had two types of errors. The first error was the addition of a non-CCITT data record at the beginning of the data portion of the file. The second was the inability of the software at the destination system to convert all the CCITT data in 5 of 32 files.

That source systems are in need of automated quality control (AQC) tools has been observed repeatedly in this and previous series of tests. Without a high degree of confidence in the quality of the transmitted documents, CALS program participants will be bogged down in labor-intensive checking and rechecking at the destination systems. To be generally accepted and useful, AQC tools should have the following characteristics:

- a. Be readily available in the immediate work environment, much as a spellcheck program is available to a word processing operator.
- b. Be thoroughly validated and certified by a neutral agency.
- c. Have more than one level of sophistication in AQC—such as tools for quick in-process checks and more thorough tools for final checkout.

d. Cover every aspect of preparation for transmission, including the preparation of declaration files and headers, SGML-tagged text files, IGES illustrations and engineering drawings, CCITT Group IV raster illustrations, and any other data encoding format added to the MIL-STD-1840A repertoire.

Visual comparison of "as-published" and "as-transmitted and -processed" images is not sufficiently reliable for test purposes. At best, visual comparison provides a "sanity check" on other test tools.

5 Exhibits

Exhibit

No. Description and Source

Exhibit No.	Description and Source	
1	TO POCD; Preface; page 1.	As published
2	TO POCD; Preface; page 1.	As transmitted and processed
3	TO POCD; Preface; page 2.	As published
4	TO POCD; Preface; page 2.	As transmitted and processed
5	TO POCX; Preface; page 1.	As published
6	TO POCX; Preface; page 1.	As transmitted and processed
7	TO POCX; Preface; page 2.	As published
8	TO POCX; Preface; page 2.	As transmitted and processed
9	TO POCD; p. 4-3, MPL table	As published
10	TO POCD; p. 4-3, MPL table	As transmitted and processed
11	TO POCX; p. 4-3, MPL table	As published
12	TO POCX; p. 4-3, MPL table	As transmitted and processed
13	TO POCD; p. 9-1.	As published
14	TO POCD; p. 9-1.	As transmitted and processed
15	TO POCX; p. 9-1.	As published
16	TO POCX; p. 9-1.	As transmitted and processed
17	TCTO POCD; p. 1.	As published
18	TCTO POCD; p. 1.	As transmitted and processed
19	TCTO POCX; p. 1.	As published
20	TCTO POCX; p. 1.	As transmitted and processed
21	OS POCD; p. 1	As published
22	OS POCD; p. 1	As transmitted and processed
23	OS POCX; p. 1	As published
24	OS POCX; p. 1	As transmitted and processed
25	TO POCD; p. 2-14, Figure 2-3 (IGES)	As published
26	TO POCD; Figure 2-3 IGES file (...iges1]f001q0003.)	As transmitted and processed
27	TO POCX; Figure 2-3 IGES file (...iges2]f001q0003.)	As transmitted and processed
28	TO POCD; Figure 2-3 Raster file (...ccitt1]f001r0003.)	As transmitted and processed
29	TO POCD; p. 2-24, Figure 2-8 (IGES)	As published
30	TO POCD; Figure 2-8 IGES file (...iges1]f001q0009.)	As transmitted and processed

Exhibit No.	Description and Source
31	TO POCX; p. 2-24, Figure 2-8 (IGES) As published
32	TO POCX; Figure 2-8 IGES file (...iges2]f001q0009.) As transmitted and processed
33	TO POCD; p. 10-1, Figure 10-1 (IGES) As published
34	TO POCD; Figure 10-1 IGES file (...iges1]f001q0022.) As transmitted and processed
35	TO POCX; p. 10-1, Figure 10-1 (IGES) As published
36	TO POCD; Figure 10-1 IGES file (...iges1]f001q0022.) As transmitted and processed
37	TO POCD; Figure 9-3 IGES file (...iges1]f001q0021.) As transmitted and processed
38	TO POCD; Figure 9-3 Raster file (...ccitt1]f001r0022.) As transmitted and processed
39	TO POCD; Figure 9-3 Raster file (...ccitt]f001]r0023.) As transmitted and processed
40	Raster version of Exhibit 36 TO POCD; Raster file (...ccitt]f001]r001.) As transmitted and processed Raster version of illustrations scanned and vectorized, not cleaned up.

As Published**PREFACE****PURPOSE.**

This publication was prepared to: (1) evaluate the capabilities of selected authoring, graphics, and composition systems, (2) determine optimum work methods using the selected systems, and (3) demonstrate compliance with Standard MIL-STD-1840, Automated Interchange of Technical Information.

SCOPE.

This publication consists of ten sections which provide a representative sampling of data from several types of USAF technical manuals. A cross-section of styles and formats was chosen to provide an evaluation of some of the more complex composition tasks encountered in the preparation of technical manuals. Since this publication is a composite of pages taken from many different technical manuals, there is no continuity of content from section to section or, necessarily, from page to page within a section. Many of the pages selected for inclusion in this publication were prepared to different military specification requirements; therefore, to establish an overall continuity of paragraph, figure and table numbering within this publication, the requirements of Specification MIL-M-38784A were observed. The following describes the contents of each section and includes explanatory notes. (Notes 1 and 2 apply to all sections.):

- Section I. Flight Manual Format. (See Note 3.)
- Section II. Organizational Maintenance Manual Format consisting of parent -2 Series Manual, Fault Isolation Manual, and Job Guide Manual formats. (See Note 4.)
- Section III. Structural Repair and Related Manuals Format consisting of Structural Repair, Pylon Overhaul, Cowl Door Overhaul, Battle Damage Repair, Corrosion Control, and Nondestructive Inspection Manual formats.
- Section IV. Illustrated Parts Breakdown Format.
- Section V. Basic Weight Checklist and Loading Data Format.
- Section VI. Workcard Format. (See Note 5.)
- Section VII. List of Applicable Publications and Tape Manual Format.
- Section VIII. Support Equipment and Component Manuals Format.
- Section IX. Cargo Loading Manual Format.
- Section X. Engine Buildup Manual Format.

As Transmitted

PREFACE

PURPOSE.

This publication was prepared to: (1) evaluate the capabilities of selected authoring, graphics, and composition systems, (2) determine optimum work methods using the selected systems, and (3) demonstrate compliance with Standard MIL-STD-1840, Automated Interchange of Technical Information.

SCOPE.

This publication consists of ten sections which provide a representative sampling of data from several types of USAF technical manuals. A cross-section of styles and formats was chosen to provide an evaluation of some of the more complex composition tasks encountered in the preparation of technical manuals. Since this publication is a composite of pages taken from many different technical manuals, there is no continuity of content from section to section or, necessarily, from page to page within a section. Many of the pages selected for inclusion in this publication were prepared to different military specification requirements; therefore, to establish an overall continuity of paragraph, figure and table numbering within this publication, the requirements of Specification MIL-M-38784A were observed. The following describes the contents of each section and includes explanatory notes. (Notes 1 and 2 apply to all sections.):

Section I. Section II.	Flight Manual Format. (See Note 3.) Organizational Maintenance Manual Format consisting of parent -2 Series Manual, Fault Isolation Manual, and Job Guide Manual formats. (See Note 4.)
Section III.	Structural Repair and Related Manuals Format consisting of Structural Repair, Pylon Overhaul, Cowl Door Overhaul, Battle Damage Repair, Corrosion Control, and Nondestructive Inspection Manual formats.
Section IV. Section V. Section VI. Section VII.	Illustrated Parts Breakdown Format. Basic Weight Checklist and Loading Data Format. Workcard Format. (See Note 5.) List of Applicable Publications and Tape Manual Format.
Section VIII.	Support Equipment and Component Manuals Format.
Section IX. Section X.	Cargo Loading Manual Format. Engine Buildup Manual Format.

As Published

- Note 1: The SGML tags listed in ATOS Technical Report No. F42650-85-C3410 were used throughout this publication. (See REFERENCES paragraph below.) In addition to the SGML tags, system specific processing commands were used to compose tabular data in the reference copy (paper copy) of this publication. It was necessary to use these processing commands to reproduce the same style and format of the original tabular material. The SGML table tags that were given in the ATOS Technical Report did not provide for such items as drawing horizontal and vertical line rules, setting column and gutter widths, aligning and justifying text within rows and columns, spanning columns with text, adjusting leading between row entries, and creating landscaped tables. Landscaped tables were created using a "content=r" SGML tag attribute not given the ATOS Technical Report. The ATOS Technical Report also did not list SGML tags for mathematical symbols. Mathematical symbols were created in the reference copy using SGML tags implemented by Datalogics. All system specific processing commands and nonconforming SGML tags and attributes were deleted from the magnetic tape version of this publication to conform to Standard MIL-STD-1840 requirements.
- Note 2: Datalogics composition software does not currently accept the input of CCITT Group IV graphics. Those pages in the reference copy have been annotated; however, a graphic has been provided on the magnetic media.
- Note 3: USAF flight manuals do not contain numbered paragraphs; however, the paragraphs are numbered here to maintain continuity within this publication and to aid in evaluating the automatic numbering capabilities of the selected composition systems.
- Note 4: The Job Guide Manual format was created using a combination of SGML table tags and system specific processing commands. The referenced ATOS Technical Report does not list specific SGML tags for creating Job Guide Manual formats.
- Note 5: The Workcard format was created using a combination of SGML table tags and system specific processing commands. The referenced ATOS Technical Report does not list specific SGML tags for creating Workcard formats.

REFERENCES.

This publication was prepared in accordance with: (1) the SGML tagging scheme outlined in Technical Report No. F42650-85-C3410, Text Standard Generalized Markup Language, Automated Technical Order System (ATOS), ATOS Project Office (OO-ALC/MMED-3) Hill AFB, Utah, dated 23 May 1986; (2) Specification MIL-M-38784A, Manuals, Technical: General Style and Format Requirements, dated 1 January 1975; and (3) Standard MIL-STD-1840, Automated Interchange of Technical Information, draft revision dated 12 December 1986.

As Transmitted

Note 1:	<p>The SGML tags listed in ATOS Technical Report No. F42650-85-C3410 were used throughout this publication. (See REFERENCES paragraph below.) In addition to the SGML tags, system specific processing commands were used to compose tabular data in the reference copy (paper copy) of this publication. It was necessary to use these processing commands to reproduce the same style and format of the original tabular material. The SGML table tags that were given in the ATOS Technical Report did not provide for such items as drawing horizontal and vertical line rules, setting column and gutter widths, aligning and justifying text within rows and columns, spanning columns with text, adjusting leading between row entries, and creating landscaped tables. Landscaped tables were created using a "contentr" SGML tag attribute not given the ATOS Technical Report. The ATOS Technical Report also did not list SGML tags for mathematical symbols. Mathematical symbols were created in the reference copy using SGML tags implemented by Datalogics. All system specific processing commands and nonconforming SGML tags and attributes were deleted from the magnetic tape version of this publication to conform to Standard MIL-STD-1840 requirements.</p>
Note 2:	<p>Datalogics composition software does not currently accept the input of CCITT Group IV graphics. Those pages in the reference copy have been annotated; however, a graphic has been provided on the magnetic media.</p>
Note 3:	<p>USAF flight manuals do not contain numbered paragraphs; however, the paragraphs are numbered here to maintain continuity within this publication and to aid in evaluating the automatic numbering capabilities of the selected composition systems.</p>
Note 4:	<p>The Job Guide Manual format was created using a combination of SGML table tags and system specific processing commands. The referenced ATOS Technical Report does not list specific SGML tags for creating Job Guide Manual formats.</p>
Note 5:	<p>The Workcard format was created using a combination of SGML table tags and system specific processing commands. The referenced ATOS Technical Report does not list specific SGML tags for creating Workcard formats.</p>

REFERENCES.

This publication was prepared in accordance with: (1) the SGML tagging scheme outlined in Technical Report No. F42650-85-C3410, Text Standard Generalized Markup Language, Automated Technical Order System (ATOS), ATOS Project Office (OO-ALC/MMED-3) Hill AFB, Utah, dated 23 May 1986; (2) Specification MIL-M-38784A, Manuals, Technical: General Style and Format Requirements, dated 1 January 1975; and (3) Standard MIL-STD-1840, Automated Interchange of Technical Information, draft revision dated 12 December 1986.

As Published**PREFACE****PURPOSE.**

This publication was prepared to: (1) evaluate the capabilities of selected authoring, graphics, and composition systems, (2) determine optimum work methods using the selected systems, and (3) demonstrate compliance with Standard MIL-STD-1840, Automated Interchange of Technical Information.

SCOPE.

This publication consists of ten sections which provide a representative sampling of data from several types of USAF technical manuals. A cross-section of styles and formats was chosen to provide an evaluation of some of the more complex composition tasks encountered in the preparation of technical manuals. Since this publication is a composite of pages taken from many different technical manuals, there is no continuity of content from section to section or, necessarily, from page to page within a section. Many of the pages selected for inclusion in this publication were prepared to different military specification requirements; therefore, to establish an overall continuity of paragraph, figure and table numbering within this publication, the requirements of Specification MIL-M-38784A were observed. The following describes the contents of each section and includes explanatory notes. (Notes 1, 2 and 3 apply to all sections.):

- Section I. Flight Manual Format. (See Note 4.)
- Section II. Organizational Maintenance Manual Format consisting of parent -2 Series Manual, Fault Isolation Manual, and Job Guide Manual formats. (See Note 5.)
- Section III. Structural Repair and Related Manuals Format consisting of Structural Repair, Pylon Overhaul, Cowl Door Overhaul, Battle Damage Repair, Corrosion Control, and Nondestructive Inspection Manual formats.
- Section IV. Illustrated Parts Breakdown Format.
- Section V. Basic Weight Checklist and Loading Data Format.
- Section VI. Workcard Format. (See Note 6.)
- Section VII. List of Applicable Publications and Tape Manual Format.
- Section VIII. Support Equipment and Component Manuals Format.
- Section IX. Cargo Loading Manual Format.
- Section X. Engine Buildup Manual Format.

Note 1: The SGML tags listed in ATOS Technical Report No. F42650-85-C3410 were used throughout this publication. (See REFERENCES paragraph below.) In addition to the SGML tags, system-specific processing commands were used to compose tabular data in the reference copy (paper copy) of this publication. It was necessary to use these processing commands to reproduce the same style and format of the original tabular material. The SGML table tags that were given in the ATOS Technical Report did not provide for such items as drawing horizontal and vertical line rules, setting column and gutter widths, aligning and justifying text within rows and columns, spanning columns with text, and adjusting leading between row entries. The release of Xyvision's composition software in use at Lockheed-Georgia does not support rotated tables. Rotated tables were therefore composed on pages whose width equals the standard page length. All system-specific processing commands and nonconforming SGML tag attributes were deleted from the magnetic tape version of this publication to conform to Standard MIL-STD-1840 requirements.

Note 2: Xyvision does not currently accept the input of CCITT Group IV graphics. Those pages in the reference copy have been annotated; however, a graphic has been provided on the magnetic media. While Xyvision does accept III V-Bit graphic input, that software is not in use at Lockheed-Georgia and no graphic has been provided on the magnetic media for that art.

As Transmitted

PREFACE

PURPOSE.

This publication was prepared to: (1) evaluate the capabilities of selected authoring, graphics, and composition systems, (2) determine optimum work methods using the selected systems, and (3) demonstrate compliance with Standard MIL-STD-1840, Automated Interchange of Technical Information.

SCOPE.

This publication consists of ten sections which provide a representative sampling of data from several types of USAF technical manuals. A cross-section of styles and formats was chosen to provide an evaluation of some of the more complex composition tasks encountered in the preparation of technical manuals. Since this publication is a composite of pages taken from many different technical manuals, there is no continuity of content from section to section or, necessarily, from page to page within a section. Many of the pages selected for inclusion in this publication were prepared to different military specification requirements; therefore, to establish an overall continuity of paragraph, figure and table numbering within this publication, the requirements of Specification MIL-M-38784A were observed. The following describes the contents of each section and includes explanatory notes. (Notes 1, 2 and 3 apply to all sections.):

Section I. \Flight Manual Format. (See Note 4.) Section II.	Organizational Maintenance Manual Format consisting of parent-2 Series Manual, Fault Isolation Manual, and Job Guide Manual formats. (See Note 5.)
Section III.	Structural Repair and Related Manuals Format consisting of Structural Repair, Pylon Overhaul, Cowl Door Overhaul, Battle Damage Repair, Corrosion Control, and Nondestructive Inspection Manual formats.
Section IV. \Illustrated Parts Breakdown Format. Section V. \Basic Weight Checklist and Loading Data Format.	
Section VI.	Workcard Format. (See Note 6.)
Section VII. \List of Applicable Publications and Tape Manual Format.	
Section VIII. \Support Equipment and Component Manuals Format.	
Section IX. \Cargo Loading Manual Format.	
Section X.	Engine Buildup Manual Format.

As Published

Note 3: Xyvision does not currently provide an SGML tag set. The tag set used was developed at Lockheed using the provisions of the system for preparing user-defined tags. Those user-defined tags were then translated using Xyvision facilities and translation tables developed at Lockheed-Georgia into SGML tags. That translation was not 100%; therefore, some text editing of the ASCII files was accomplished to resolve difficulties of translation.

Note 4: USAF flight manuals do not contain numbered paragraphs; however, the paragraphs are numbered here to maintain continuity within this publication and to aid in evaluating the automatic numbering capabilities of the selected composition systems.

Note 5: The Job Guide Manual format was created using a combination of SGML table tags and system-specific processing commands. The referenced ATOS Technical Report does not list specific SGML tags for creating Job Guide Manual formats.

Note 6: The Workcard format was created using a combination of SGML table tags and system-specific processing commands. The referenced ATOS Technical Report does not list specific SGML tags for creating Workcard formats.

REFERENCES.

This publication was prepared in accordance with: (1) the SGML tagging scheme outlined in Technical Report No. F42650-85-C3410, Text Standard Generalized Markup Language, Automated Technical Order System (ATOS), ATOS Project Office (OO-ALC/MMED-3) Hill AFB, Utah, dated 23 May 1986; (2) Specification MIL-M-38784A, Manuals, Technical: General Style and Format Requirements, dated 1 January 1975; and (3) Standard MIL-STD-1840, Automated Interchange of Technical Information, draft revision dated 12 December 1986.

As Transmitted

Note 1: The SGML tags listed in ATOS Technical Report No. F42650-85-C3410 were used throughout this publication. (See REFERENCES paragraph below.) In addition to the SGML tags, system-specific processing commands were used to compose tabular data in the reference copy (paper copy) of this publication. It was necessary to use these processing commands to reproduce the same style and format of the original tabular material. The SGML table tags that were given in the ATOS Technical Report did not provide for such items as drawing horizontal and vertical line rules, setting column and gutter widths, aligning and justifying text within rows and columns, spanning columns with text, and adjusting leading between row entries. The release of Xyvision's composition software in use at Lockheed-Georgia does not support rotated tables. Rotated tables were therefore composed on pages whose width equals the standard page length. All system-specific processing commands and nonconforming SGML tag attributes were deleted from the magnetic tape version of this publication to conform to Standard MIL-STD-1840 requirements.

Note 2: Xyvision does not currently accept the input of CCITT Group IV graphics. Those pages in the reference copy have been annotated; however, a graphic has been provided on the magnetic media. While Xyvision does accept III V-Bit graphic input, that software is not in use at Lockheed-Georgia and no graphic has been provided on the magnetic media for that art.

Note 3: Xyvision does not currently provide an SGML tag set. The tag set used was developed at Lockheed using the provisions of the system for preparing user-defined tags. Those user-defined tags were then translated using Xyvision facilities and translation tables developed at Lockheed-Georgia into SGML tags. That translation was not 100%; therefore, some text editing of the ASCII files was accomplished to resolve difficulties of translation.

Note 4: USAF flight manuals do not contain numbered paragraphs; however, the paragraphs are numbered here to maintain continuity within this publication and to aid in evaluating the automatic numbering capabilities of the selected composition systems.

Note 5: The Job Guide Manual format was created using a combination of SGML table tags and system-specific processing commands. The referenced ATOS Technical Report does not list specific SGML tags for creating Job Guide Manual formats.

Note 6: The Workcard format was created using a combination of SGML table tags and system-specific processing commands. The referenced ATOS Technical Report does not list specific SGML tags for creating Workcard formats.

Exhibit 9

As Published

TO LGC-ATM-POCD-1840

FIGURE & INDEX NUMBER	PART NUMBER	FSCM	DESCRIPTION	UNITS PER ASSY	USABLE ON CODE	SMR CODE
131			UTILITY HYDRAULIC PANEL PIPING.....			
	368053-5	98897	. HYDRAULIC INSTL, UTILITY PAN- EL (NHA 388007-5 AND 3311007-1) (MODIFIED BY 3314214-3) (FIG. 132)	NP	A	
	3330886-1	98897	. HYDRAULIC INSTL, UTILITY PAN- EL (FIG. 132).....	NP	C	
-1	370741-62	98897	. . TUBE ASSY, UTILITY PRES- SURE (FIG. 133).....	1	A	
-1	370741-263	98897	. . TUBE ASSY, UTILITY PRES- SURE (FIG. 133).....	1	B	
-1	370741-868	98897	. . TUBE ASSY, UTILITY PRES- SURE (FIG. 133).....	1	C	
-2	MS21907D12	96906	. . ELBOW.....	1		
-3	MS21910D12	96906	. . TEE.....	1		
-4	AN6289D12	88044	. . NUT.....	2		
-5	M83248-2-912	83259	. . PACKING.....	2		
-6	MS28773-12	96906	. . RETAINER.....	2		
-7	AN938D12	88044	. . TEE.....	1		
-8	MS21902D12	96906	. . UNION.....	1		
-9	M83248-2-912	83259	. . PACKING.....	1		
-10	AS1002-121204	92003	. . TEE.....	1		
-11	AN6289D12	88044	. . NUT.....	1		
-12	M83248-2-912	83259	. . PACKING.....	1		
-13	MS28773-12	96906	. . RETAINER.....	1		
-14	MS28892-12	96906	. . VALVE.....	1		
-15	M83248-2-912	83259	. . PACKING.....	1		
-16	370741-160	98897	. . TUBE ASSY, UTILITY PRESSURE.....	1		
-17	370741-71	98897	. . TUBE ASSY, UTILITY PRESSURE.....	1		
-18	370741-159	98897	. . TUBE ASSY, UTILITY PRESSURE.....	1		
-19	370741-191	98897	. . TUBE ASSY, UTILITY PRESSURE.....	1	A	
-20	19D2-3L	76906	. . VALVE, HYDRAULIC PRESSURE SNUBBER (LOCKHEED SPEC DWG 695767-1).....	1		
-21	MS28762-4-230	96906	. . HOSE ASSY.....	1		
-21A	LS35104HS-55	98897	. . DECAL.....	1		
-22	370741-59	98897	. . TUBE ASSY, LANDING GEAR DOWN.....	1		
-23	370741-60	98897	. . TUBE ASSY, LANDING GEAR UP.....	1		
-24	MS21908D12	96906	. . ELBOW.....	1		
-25	AN6289D12	88044	. . NUT.....	1		
-26	M83248-2-912	83259	. . PACKING.....	1		
-27	MS28773-12	96906	. . RETAINER.....	1		
-28	370741-58	98897	. . TUBE ASSY, UTILITY RETURN (FIG. 133).....	1	A	
-28	370741-801	98897	. . TUBE ASSY, UTILITY RETURN (FIG. 133).....	1	B	
-28	370741-870	98897	. . TUBE ASSY, UTILITY RETURN (FIG. 133).....	1	C	
-29	370741-989	98897	. . TUBE ASSY, UTILITY HYDRAU- LIC RETURN.....	1	A	
-30	MS21902D12	96906	. . UNION.....	1		
-31	M83248-2-912	83259	. . PACKING.....	1		

Exhibit 10

T.O. POCD

As Transmitted

FIG & INDEX NO.	PART NUMBER	FSCM	DESCRIPTION							UNITS PER ASSY	USABLE ON CODE	SMR CODE
			1	2	3	4	5	6	7			
131-			UTILITY HYDRAULIC PANEL.....									
	368053-5	98897	PIPING HYDRAULIC INSTL, UTILITY.....							NP	A	
			PANEL (NHA 388007-5 AND 3311007-1) (MODIFIED BY 3314214- 3) (FIG. 132)									
	3330886-1	98897	HYDRAULIC INSTL, UTILITY.....							NP	C	
			PANEL (FIG. 132)									
-1	370741-62	98897	TUBE ASSY, UTILITY.....							1	A	
			PRESSURE (FIG. 133)									
	370741-263	98897	TUBE ASSY, UTILITY.....							1	B	
			PRESSURE (FIG. 133)									
	370741-868	98897	TUBE ASSY, UTILITY.....							1	C	
			PRESSURE (FIG. 133)									
-2	MS21907D12	96906	ELBOW.....							1		
-3	MS21910D12	96906	TEE.....							1		
-4	A N6289D12	88044	NUT.....							2		
-5	M83248-2-912	83259	PACKING.....							2		
-6	MS28773-12	96906	RETAINER.....							2		
-7	A N938D12	88044	TEE.....							1		
-8	MS21902D12	96906	UNION.....							1		
-9	M83248-2-912	83259	PACKING.....							1		
-10	AS1002-121204	92003	TEE.....							1		
-11	A N6289D12	88044	NUT.....							1		
-12	M83248-2-912	83259	PACKING.....							1		
-13	MS28773-12	96906	RETAINER.....							1		
-14	MS28892-12	96906	VALVE.....							1		
-15	M83248-2-912	83259	PACKING.....							1		
-16	370741-160	98897	TUBE ASSY, UTILITY.....							1		
			PRESSURE.									
-17	370741-71	98897	TUBE ASSY, UTILITY.....							1		
			PRESSURE.									
-18	370741-159	98897	TUBE ASSY, UTILITY.....							1		
			PRESSURE.									
-19	370741-191	98897	TUBE ASSY, UTILITY.....							1	A	
			PRESSURE.									
-20	19D2-3L	76906	VALVE, HYDRAULIC.....							1		
			PRESSURE SNUBBER (LOCK- HEED SPEC DWG 695767-1)									
-21	MS28762-4-230	96906	HOSE ASSY.....							1		
-21A	LS35104HS-55	98897	DECAL.....							1		
-22	370741-59	98897	TUBE ASSY, LANDING GEAR.....							1		
			DOWN									
-23	370741-60	98897	TUBE ASSY, LANDING GEAR.....							1		
			UP									
-24	MS21908D12	96906	ELBOW.....							1		
-25	A N6289D12	88044	NUT.....							1		
-26	M83248-2-912	83259	PACKING.....							1		
-27	MS28773-12	96906	RETAINER.....							1		
-28	370741-68	98897	TUBE ASSY, UTILITY RETURN.....							1	A	
			(FIG. 133)									
	370741-801	98897	TUBE ASSY, UTILITY RETURN.....							1	B	
			(FIG. 133)									
	370741-870	98897	TUBE ASSY, UTILITY RETURN.....							1	C	
			(FIG. 133)									
-29	370741-989	98897	TUBE ASSY, UTILITY.....							1	A	
			HYDRAULIC RETURN									
-30	MS21902D12	96906	UNION.....							1		
-31	M83248-2-912	83259	PACKING.....							1		
-32	A N938D12	88044	TEE.....							1	A	

As Published

FIGURE & INDEX NUMBER	PART NUMBER	FSCM	DESCRIPTION							UNITS PER ASSY	USABLE ON CODE	SMR CODE
			1	2	3	4	5	6	7			
131			UTILITY HYDRAULIC PANEL PIPING.....									
	368053-5	98897	. HYDRAULIC INSTL, UTILITY PANEL (NHA 388007-5 AND 3311007-1) (MODIFIED BY 3314214-3) (FIG. 132).....							NP	A	
	3330886-1	98897	. HYDRAULIC INSTL, UTILITY PANEL (FIG. 132).....							NP	C	
-1	370741-62	98897	. TUBE ASSY, UTILITY PRES- SURE (FIG. 133).....							1	A	
-1	370741-263	98897	. TUBE ASSY, UTILITY PRES- SURE (FIG. 133).....							1	B	
-1	370741-868	98897	. TUBE ASSY, UTILITY PRES- SURE (FIG. 133).....							1	C	
-2	MS21907D12	96906	. ELBOW							1		
-3	MS21910D12	96906	. TEE.....							1		
-4	AN6289D12	88044	. NUT							2		
-5	M83248-2-912	83259	. PACKING.....							2		
-6	MS28773-12	96906	. RETAINER							2		
-7	AN938D12	88044	. TEE.....							1		
-8	MS21902D12	96906	. UNION							1		
-9	M83248-2-912	83259	. PACKING.....							1		
-10	AS1002-121204	92003	. TEE.....							1		
-11	AN6289D12	88044	. NUT							1		
-12	M83248-2-912	83259	. PACKING.....							1		
-13	MS28773-12	96906	. RETAINER							1		
-14	MS28892-12	96906	. VALVE							1		
-15	M83248-2-912	83259	. PACKING.....							1		
-16	370741-160	98897	. TUBE ASSY, UTILITY PRES- SURE.....							1		
-17	370741-71	98897	. TUBE ASSY, UTILITY PRES- SURE.....							1		
-18	370741-159	98897	. TUBE ASSY, UTILITY PRES- SURE.....							1		
-19	370741-191	98897	. TUBE ASSY, UTILITY PRES- SURE.....							1	A	
-20	19D2-3L	76906	. VALVE, HYDRAULIC PRES- SURE SNUBBER (LOCKHEED SPEC DWG 695767-1).....							1		
-21	MS28762-4-230	96906	. HOSE ASSY							1		
-21A	LS35104HS-55	98897	. DECAL							1		
-22	370741-59	98897	. TUBE ASSY, LANDING GEAR DOWN.....							1		
-23	370741-60	98897	. TUBE ASSY, LANDING GEAR UP							1		
-24	MS21908D12	96906	. ELBOW							1		
-25	AN6289D12	88044	. NUT							1		
-26	M83248-2-912	83259	. PACKING.....							1		
-27	MS28773-12	96906	. RETAINER							1		
-28	370741-58	98897	. TUBE ASSY, UTILITY RETURN (FIG. 133).....							1	A	
-28	370741-801	98897	. TUBE ASSY, UTILITY RETURN (FIG. 133).....							1	B	
-28	370741-870	98897	. TUBE ASSY, UTILITY RETURN (FIG. 133).....							1	C	

As Transmitted

SECTION IV

ILLUSTRATED PARTS BREAKDOWN FORMAT

4-1. GENERAL. This section provides representative data from an Illustrated Parts Breakdown manual.

(Optographics Via IGES)(ART081)

FIG & INDEX NO.	PART NUMBER	FSCM	DESCRIPTION 1 2 3 4 5 6 7	UNITS PER ASSY	USABLE ON CODE	SMR CODE
131-			UTILITY HYDRAULIC PANEL..... PIPING			
	368053-6	98897	HYDRAULIC INSTL, UTILITY..... PANEL (NHA 388007-5 AND 3311007-1) (MODIFIED BY 3314214- 3) (FIG. 132)	NP	A	
	3330886-1	98897	HYDRAULIC INSTL, UTILITY..... PANEL (FIG. 132)	NP	C	
-1	370741-62	98897	TUBE ASSY, UTILITY..... PRESSURE (FIG. 133)	1	A	
	370741-263	98897	TUBE ASSY, UTILITY..... PRESSURE (FIG. 133)	1	B	
	370741-868	98897	TUBE ASSY, UTILITY..... PRESSURE (FIG. 133)	1	C	
-2	MS21907D12	96906	ELBOW	1		
-3	MS21910D12	96906	TEE.....	1		
-4	AN6289D12	88044	NUT	2		
-5	M83248-2-912	83259	PACKING	2		
-6	MS28773-12	96906	RETAINER.....	2		
-7	AN938D12	88044	TEE.....	1		
-8	MS21902D12	96906	UNION	1		
-9	M83248-2-912	83259	PACKING	1		
-10	AS1002-121204	92003	TEE.....	1		
-11	AN6289D12	88044	NUT	1		
-12	M83248-2-912	83259	PACKING	1		
-13	MS28773-12	96906	RETAINER.....	1		
-14	MS28892-12	96906	VALVE.....	1		
-15	M83248-2-912	83259	PACKING	1		
-16	370741-160	98897	TUBE ASSY, UTILITY..... PRESSURE	1		
-17	370741-71	98897	TUBE ASSY, UTILITY..... PRESSURE	1		
-18	370741-159	98897	TUBE ASSY, UTILITY..... PRESSURE	1		
-19	370741-191	98897	TUBE ASSY, UTILITY..... PRESSURE	1	A	
-20	19D2-3L	76906	VALVE, HYDRAULIC..... PRESSURE SNUBBER (LOCK- HEED SPEC DWG 695767-1)	1		
-21	MS28762-4-230	96906	HOSE ASSY.....	1		
-21A	LS35104HS-55	98897	DECAL	1		
-22	370741-59	98897	TUBE ASSY, LANDING GEAR..... DOWN	1		
-23	370741-60	98897	TUBE ASSY, LANDING GEAR..... UP	1		
-24	MS21908D12	96906	ELBOW	1		

As Published

SECTION IX

CARGO LOADING MANUAL FORMAT

9-1. GENERAL: This section provides representative data from a Cargo Loading manual.

a. Load planning is a primary requirement for achieving efficient on/off loading operations, correct load placement in the airplane, correct tiedown of the cargo after loading to ensure maximum utilization of the available cargo space within the airplane, and for establishing a minimum turnaround time for the airplane at its destination.

b. Load planning covers many factors that must be taken into consideration before any actual loading is accomplished. Load planning also makes it possible to know in advance whether a given load can be carried in the airplane while still maintaining the designed purpose of the particular mission. Load planning will also determine any additional loading aids that may be required for loading the cargo. The following are some items that should be considered in load planning.

(1) Ensure that cargo is prepared for air shipment in accordance with appropriate directives.

(2) Cargo inspection-contaminated items, general condition, dangerous material.

(3) Assemble cargo to be transported.

(4) Select the desired cargo center-of-gravity location limits as described in applicable technical manual weight and balance data.

(5) For items having critical loading clearances, determine if the cargo item can be loaded.

(6) Ensure that positioned cargo units are within cargo floor limitations of figure 4D-4.

(7) Plan position of cargo so that jettisonable cargo can be readily jettisoned.

(8) Compute total cargo load center of gravity location. (See figure 4A-7.)

(9) Compare total cargo load center of gravity with desired airplane center of gravity (if center of gravity differs appreciably, shift cargo to reduce differences).

(10) Compare contact-area pressures with contact-area pressure limitations.

(11) Compute compartment loads and check compartment load limitations.

(12) Determine shoring requirements, either rolling or parking.

c. The cargo load must be planned so that the center of gravity of the loaded airplane will be within the specified forward and aft limits for any given operating condition. A general rule for loading cargo into the airplane is to position the heavy units in the area of the optimum airplane center of gravity, and lighter units forward and aft to balance the load. To avoid trial-and-error shifting of heavy and bulky cargo units, the loadmaster may first plan the cargo placement and tentative tiedown on paper.

WARNING

Failure to comply with the following procedures could result in the airplane center of gravity limits being exceeded and result in an unsafe flight condition.

d. The agency offering cargo for air shipment is responsible for marking each item of cargo and all vehicle type cargo with the correct gross weight and center of balance point as follows:

(1) Any item measuring 10 feet or longer.

(2) Any item having a balance point at other than its center.

(3) Vehicle type cargo having a load carrying capability shall be marked indicating an empty or loaded center of gravity, as appropriate.

(4) Items not marked as outlined above shall not be accepted for airlift.

(5) The weight should be presented in terms of weight per pallet for cargo loads that span more than one pallet.

(6) If it is not possible to determine the weight per pallet for cargo loads that span more than one pallet, the combined weight will be provided and the calculated CG will be marked on the shipment.

9-2. GENERAL WEIGHT AND BALANCE REQUIREMENTS.

a. Maximum Weight Per Mission. The maximum weight that can be carried on any mission is limited by the maximum allowable gross weight and is dependent upon the airplane basic weight, number of crew members, and the amount of fuel and oil

As Transmitted

SECTION IX

CARGO LOADING MANUAL FORMAT

9-1. GENERAL. This section provides representative data from a Cargo Loading manual.

a. Load planning is a primary requirement for achieving efficient on/off loading operations, correct load placement in the airplane, correct tiedown of the cargo after loading to ensure maximum utilization of the available cargo space within the airplane, and for establishing a minimum turnaround time for the airplane at its destination.

b. Load planning covers many factors that must be taken into consideration before any actual loading is accomplished. Load planning also makes it possible to know in advance whether a given load can be carried in the airplane while still maintaining the designed purpose of the particular mission. Load planning will also determine any additional loading aids that may be required for loading the cargo. The following are some items that should be considered in load planning.

(1) \Ensure that cargo is prepared for air shipment in accordance with appropriate directives.

(2) \Cargo inspection-contaminated items, general condition, dangerous material.

(3) \Assemble cargo to be transported.

(4) \Select the desired cargo center-of-gravity location limits as described in applicable technical manual weight and balance data.

(5) \For items having critical loading clearances, determine if the cargo item can be loaded.

(6) \Ensure that positioned cargo units are within cargo floor limitations of figure 4D-4.

(7) \Plan position of cargo so that jettisonable cargo can be readily jettisoned.

(8) \Compute total cargo load center of gravity location. (See figure 4A-7.)

(9) \Compare total cargo load center of gravity with desired airplane center of gravity (if center of gravity differs appreciably, shift cargo to reduce differences).

(10) \Compare contact-area pressures with contact-area pressure limitations.

(11) \Compute compartment loads and check compartment load limitations.

(12) \Determine shoring requirements, either rolling or parking.

c. The cargo load must be planned so that the center of gravity of the loaded airplane will be within the specified forward and aft limits for any given operating condition. A general rule for loading cargo into the airplane is to position the heavy units in the area of the optimum airplane center of gravity, and lighter units forward and aft to balance the load. To avoid trial-and-error shifting of heavy and bulky cargo units, the loadmaster may first plan the cargo placement and tentative tiedown on paper.

WARNING

Failure to comply with the following procedures could result in the airplane center of gravity limits being exceeded and result in an unsafe flight condition.

d. The agency offering cargo for air shipment is responsible for marking each item of cargo and all vehicle type cargo with the correct gross weight and center of balance point as follows:

(1) \Any item measuring 10 feet or longer.

(2) \Any item having a balance point at other than its center.

(3) \Vehicle type cargo having a load carrying capability shall be marked indicating an empty or loaded center of gravity, as appropriate.

(4) \Items not marked as outlined above shall not be accepted for airlift.

(5) \The weight should be presented in terms of weight per pallet for cargo loads that span more than one pallet.

(6) \If it is not possible to determine the weight per pallet for cargo loads that span more than one pallet, the combined weight will be provided and the calculated CG will be marked on the shipment.

9-2. GENERAL WEIGHT AND BALANCE REQUIREMENTS.

a. Maximum Weight Per Mission. The maximum weight that can be carried on any mission is limited by the maximum allowable gross weight and is dependent upon the airplane basic weight, number of crew members, and the amount of fuel

As Published

Section IX. CARGO LOADING MANUAL FORMAT

9-1. GENERAL. This section provides representative data from a Cargo Loading manual.

a. Load planning is a primary requirement for achieving efficient on/off loading operations, correct load placement in the airplane, correct tiedown of the cargo after loading to ensure maximum utilization of the available cargo space within the airplane, and for establishing a minimum turnaround time for the airplane at its destination.

b. Load planning covers many factors that must be taken into consideration before any actual loading is accomplished. Load planning also makes it possible to know in advance whether a given load can be carried in the airplane while still maintaining the designed purpose of the particular mission. Load planning will also determine any additional loading aids that may be required for loading the cargo. The following are some items that should be considered in load planning.

(1) Ensure that cargo is prepared for air shipment in accordance with appropriate directives.

(2) Cargo inspection-contaminated items, general condition, dangerous material.

(3) Assemble cargo to be transported.

(4) Select the desired cargo center-of-gravity location limits as described in applicable technical manual weight and balance data.

(5) For items having critical loading clearances, determine if the cargo item can be loaded.

(6) Ensure that positioned cargo units are within cargo floor limitations of figure 4D-4.

(7) Plan position of cargo so that jettisonable cargo can be readily jettisoned.

(8) Compute total cargo load center of gravity location. (See figure 4A-7.)

(9) Compare total cargo load center of gravity with desired airplane center of gravity (if center of gravity differs appreciably, shift cargo to reduce differences).

(10) Compare contact-area pressures with contact-area pressure limitations.

(11) Compute compartment loads and check compartment load limitations.

(12) Determine shoring requirements, either rolling or parking.

c. The cargo load must be planned so that the center of gravity of the loaded airplane will be within the specified forward and aft limits for any given operating condition. A general rule for loading cargo into the airplane is to position the heavy units in the area of the optimum airplane center of gravity, and lighter units forward and aft to balance the load. To avoid trial-and-error shifting of heavy and bulky cargo units, the loadmaster may first plan the cargo placement and tentative tiedown on paper.

WARNING

Failure to comply with the following procedures could result in the airplane center of gravity limits being exceeded and result in an unsafe flight condition.

d. The agency offering cargo for air shipment is responsible for marking each item of cargo and all vehicle type cargo with the correct gross weight and center of balance point as follows:

(1) Any item measuring 10 feet or longer.

(2) Any item having a balance point at other than its center.

(3) Vehicle type cargo having a load carrying capability shall be marked indicating an empty or loaded center of gravity, as appropriate.

(4) Items not marked as outlined above shall not be accepted for airlift.

(5) The weight should be presented in terms of weight per pallet for cargo loads that span more than one pallet.

(6) If it is not possible to determine the weight per pallet for cargo loads that span more than one pallet, the combined weight will be provided and the calculated CG will be marked on the shipment.

9-2. GENERAL WEIGHT AND BALANCE REQUIREMENTS.

a. Maximum Weight Per Mission. The maximum weight that can be carried on any mission is limited by the maximum allowable gross weight and is dependent upon the airplane basic weight, number of crew members, and the amount of fuel and oil onboard the airplane. The center-of-gravity location is vitally important to airplane stability during flight. The airplane must be flown only when the center of gravity,

As Transmitted

SECTION IX

CARGO LOADING MANUAL FORMAT

9-1. GENERAL. This section provides representative data from a Cargo Loading manual.

a. Load planning is a primary requirement for achieving efficient on/off loading operations, correct load placement in the airplane, correct tiedown of the cargo after loading to ensure maximum utilization of the available cargo space within the airplane, and for establishing a minimum turnaround time for the airplane at its destination.

b. Load planning covers many factors that must be taken into consideration before any actual loading is accomplished. Load planning also makes it possible to know in advance whether a given load can be carried in the airplane while still maintaining the designed purpose of the particular mission. Load planning will also determine any additional loading aids that may be required for loading the cargo. The following are some items that should be considered in load planning.

- (1) \Ensure that cargo is prepared for air shipment in accordance with appropriate directives.
- (2) \Cargo inspection-contaminated items, general condition, dangerous material.
- (3) \Assemble cargo to be transported.
- (4) \Select the desired cargo center-of-gravity location limits as described in applicable technical manual weight and balance data.
- (5) \For items having critical loading clearances, determine if the cargo item can be loaded.
- (6) \Ensure that positioned cargo units are within cargo floor limitations of figure 4D-4.
- (7) \Plan position of cargo so that jettisonable cargo can be readily jettisoned.
- (8) \Compute total cargo load center of gravity location. (See figure 4A-7.)
- (9) \Compare total cargo load center of gravity with desired airplane center of gravity (if center of gravity differs appreciably, shift cargo to reduce differences).
- (10) Compare contact-area pressures with contact-area pressure limitations.
- (11) \Compute compartment loads and check compartment load limitations.
- (12) \Determine shoring requirements, either rolling or parking.

c. The cargo load must be planned so that the center of gravity of the loaded airplane will be within the specified forward and aft limits for any given operating condition. A general rule for loading cargo into the airplane is to position the heavy units in the area of the optimum airplane center of gravity, and lighter units forward and aft to balance the load. To avoid trial-and-error shifting of heavy and bulky cargo units, the loadmaster may first plan the cargo placement and tentative tiedown on paper.

WARNING

Failure to comply with the following procedures could result in the airplane center of gravity limits being exceeded and result in an unsafe flight condition.

\The agency offering cargo for air shipment is responsible for marking each item of cargo and all vehicle type cargo with the correct gross weight and center of balance point as follows:

- (1) \Any item measuring 10 feet or longer.
- (2) \Any item having a balance point at other than its center.
- (3) \Vehicle type cargo having a load carrying capability shall be marked indicating an empty or loaded center of gravity, as appropriate.
- (4) \Items not marked as outlined above shall not be accepted for airlift.
- (5) \The weight should be presented in terms of weight per pallet for cargo loads that span more than one pallet.
- (6) \If it is not possible to determine the weight per pallet for cargo loads that span more than one pallet, the combined weight will be provided and the calculated CG will be marked on the shipment.

9-2. GENERAL WEIGHT AND BALANCE REQUIREMENTS.

a. The maximum weight that can be carried on any mission is limited by the maximum allowable gross weight and is dependent upon the airplane basic weight, number of crew members, and the amount of fuel and oil onboard the airplane. The

Exhibit 17

As Published

**DEPARTMENT OF THE AIR FORCE
TECHNICAL ORDER**

**TCTO LGC-ATM-POCD-1840
DATA CODE: 1234567
30 JUNE 1987**

Rescission date: 30 JUNE 1988

**INSPECTION OF GENERATOR POWER FEEDER CABLES
FOR PROPER CLAMPING, C-5 AIRCRAFT**

NOTE Commanders are responsible for bringing this publication to the attention of all Air Force personnel cleared for operation of the affected system. All flight personnel will, prior to next flight, be made aware of the effect this TCTO has upon the operation of the equipment.

1. APPLICATION.

a. This technical order is applicable to all series C-5A aircraft and C-5B aircraft AF83-1285, 84-0059 through 84-0062, and 85-001 through 85-004. The intent of this inspection will be accomplished on C-5B aircraft AF85-005 and subsequent by the Contractor during production prior to delivery and on the following C-5A aircraft during wing modification: AF66-8307, 68-217, 68-224, 68-225, 69-003, 70-446, 70-460, 70-465, and 70-467.

b. Kits are not required by this TCTO.

c. Kit proof testing of this technical order in accordance with T.O. 00-5-15 has been waived by SA-ALC/MMURT.

2. PURPOSE.

The purpose of this TCTO is to ensure proper installation of generator power feeder cables in the outer wing leading edge near pylon No. 1.

3. WHEN TO BE ACCOMPLISHED.

Not later than 30 days after receipt of this TCTO. Failure to accomplish this TCTO by the preceding specified number of days shall automatically restrict operations or shall be justification for withdrawing affected system/equipment from service until compliance is accomplished.

4. BY WHOM TO BE ACCOMPLISHED.

Organizational/Intermediate level maintenance.

5. WHAT IS REQUIRED.

NOTE

AF activities will ensure that requisitioning of TCTO parts is effected in an expeditious manner to ensure accomplishment of this modification within the designated time period.

This technical order is required for official use or for administrative or operational purposes only. Distribution is limited to US Government agencies. Other requests for this document must be referred to San Antonio ALC/MMEDT, Kelly AFB, TX 78241-5990. .

As Transmitted

DEPARTMENT OF THE AIR FORCE TCTO LGC-ATM-POCD-1840
TECHNICAL ORDER 1234567
30 JUNE 1987
30 JUNE 1988
DATA CODE:

**INSPECTION OF GENERATOR POWER FEEDER CABLES
FOR PROPER CLAMPING, C-5 AIRCRAFT**

NOTE Commanders are responsible for bringing this publication to the attention of all Air Force personnel cleared for operation of the affected system. All flight personnel will, prior to next flight, be made aware of the effect this TCTO has upon the operation of the equipment. San Antonio ALC/MMEDT, Kelly AFB, TX 78241-5990.

1. APPLICATION.

a. This technical order is applicable to all series C-5A aircraft and C-5B aircraft AF83-1285, 84-0059 through 84-0062, and 85-001 through 85-004. The intent of this inspection will be accomplished on C-5B aircraft AF85-005 and subsequent by the Contractor during production prior to delivery and on the following C-5A aircraft during wing modification: AF66-8307, 68-217, 68-224, 68-225, 69-003, 70-446, 70-460, 70-465, and 70-467.

b. Kits are not required by this TCTO.

c. Kit proof testing of this technical order in accordance with T.O. 00-5-15 has been waived by SA-ALC/MMURT.

2. PURPOSE.

The purpose of this TCTO is to ensure proper installation of generator power feeder cables in the outer wing leading edge near pylon No. 1.

3. WHEN TO BE ACCOMPLISHED.

Not later than 30 days after receipt of this TCTO. Failure to accomplish this TCTO by the preceding specified number of days shall automatically restrict operations or shall be justification for withdrawing affected system/equipment from service until compliance is accomplished.

4. BY WHOM TO BE ACCOMPLISHED.

Organizational/Intermediate level maintenance.

5. WHAT IS REQUIRED.

NOTE

AF activities will ensure that requisitioning of TCTO parts is effected in an expeditious manner to ensure accomplishment of this modification within the designated time period.

a. Supply Information and Requirements.

(1) Kits/Parts/Materials Required.

The following parts will not be furnished as a complete kit. Complete kit concept waived by J. Bailey, SA-ALC/MMURT AV945-6924, for initial installation and will be requisitioned in accordance with AFM 67-1.

As Published

DEPARTMENT OF THE AIR FORCE
TECHNICAL ORDER

T.O. LGC-ATM-POCX-1840

DATA CODE: 1234567

30 JUNE 1987

Rescission date: 30 JUNE 1988

**INSPECTION OF GENERATOR POWER FEEDER CABLES
FOR PROPER CLAMPING, C-5 AIRCRAFT**

NOTE Commanders are responsible for bringing this publication to the attention of all Air Force personnel cleared for operation of the affected system. All flight personnel will, prior to next flight, be made aware of the effect this TCTO has upon the operation of the equipment.

1. APPLICATION.

a. This technical order is applicable to all series C-5A aircraft and C-5B aircraft AF83-1285, 84-0059 through 84-0062, and 85-001 through 85-004. The intent of this inspection will be accomplished on C-5B aircraft AF85-005 and subsequent by the Contractor during production prior to delivery and on the following C-5A aircraft during wing modification: AF66-8307, 68-217, 68-224, 68-225, 69-003, 70-446, 70-460, 70-465, and 70-467.

b. Kits are not required by this TCTO.

c. Kit proof testing of this technical order in accordance with T.O. 00-5-15 has been waived by SA-ALC/MMURT.

2. PURPOSE.

The purpose of this TCTO is to ensure proper installation of generator power feeder cables in the outer wing leading edge near pylon No. 1.

3. WHEN TO BE ACCOMPLISHED.

Not later than 30 days after receipt of this TCTO. Failure to accomplish this TCTO by the preceding specified number of days shall automatically restrict operations or shall be justification for withdrawing affected system/equipment from service until compliance is accomplished.

4. BY WHOM TO BE ACCOMPLISHED.

Organizational/Intermediate level maintenance.

5. WHAT IS REQUIRED.

NOTE

AF activities will ensure that requisitioning of TCTO parts is effected in an expeditious manner to ensure accomplishment of this modification within the designated time period.

a. Supply Information and Requirements.

(1) Kits/Parts/Materials Required.

The following parts will not be furnished as a complete kit. Complete kit concept waived by J. Bailey, SA-ALC/MMURT AV945-6924, for initial installation and will be requisitioned in accordance with AFM 67-1.

This technical order is required for official use or for administrative or operational purposes only. Distribution is limited to US Government agencies. Other requests for this document must be referred to San Antonio ALC/MMEDT, Kelly AFB, TX 78241-5990.

Exhibit 20

As Transmitted

DEPARTMENT OF THE AIR FORCE TCTO LGC-ATM-POCX-1840
TECHNICAL ORDER DATA CODE: 1234567
30 JUNE 1987

Rescission date: 30 JUNE 1988

**INSPECTION OF GENERATOR POWER FEEDER CABLES FOR PROPER
CLAMPING, C-5 AIRCRAFT**

NOTE Commanders are responsible for bringing this publication to the attention of all Air Force personnel cleared for operation of the affected system. All flight personnel will, prior to next flight, be made aware of the effect this TCTO has upon the operation of the equipment.

1. APPLICATION.

a. This technical order is applicable to all series C-5A aircraft and C-5B aircraft AF83-1285, 84-0059 through 84-0062, and 85-001 through 85-004. The intent of this inspection will be accomplished on C-5B aircraft AF85-005 and subsequent by the Contractor during production prior to delivery and on the following C-5A aircraft during wing modification: AF66-8307, 68-217, 68-224, 68-225, 69-003, 70-446, 70-460, 70-465, and 70-467.

b. Kits are not required by this TCTO.

c. Kit proof testing of this technical order in accordance with T.O. 00-5-15 has been waived by SA-ALC/MMURT.

2. PURPOSE.

The purpose of this TCTO is to ensure proper installation of generator power feeder cables in the outer wing leading edge near pylon No. 1.

3. WHEN TO BE ACCOMPLISHED.

Not later than 30 days after receipt of this TCTO. Failure to accomplish this TCTO by the preceding specified number of days shall automatically restrict operations or shall be justification for withdrawing affected system/equipment from service until compliance is accomplished.

4. BY WHOM TO BE ACCOMPLISHED.

Organizational/Intermediate level maintenance.

This technical order is required for official use or for administrative or operational purposes only. Distribution is limited to US Government agencies. Other requests for this document must be referred to San Antonio ALC/MMEDT, Kelly AFB, TX 78241-5990 .

As Published

OPERATIONAL SUPPLEMENT

TECHNICAL MANUAL

ORGANIZATIONAL MAINTENANCE

INSTRUMENTS

USAF SERIES

C-5A AND C-5B

AIRCRAFT

F33657-82-C-2117

THIS PUBLICATION SUPPLEMENTS T.O. 1C-5A-2-6 DATED 29 MARCH 1985. Reference to this supplement will be made on the title page of the basic publication by personnel responsible for maintaining the publication in current status.

COMMANDERS ARE RESPONSIBLE FOR BRINGING THIS SUPPLEMENT TO THE ATTENTION OF ALL AFFECTED AF PERSONNEL

This publication is required for official use or for administrative or operational purposes only. Distribution is limited to US Government agencies. Other requests for this document must be referred to SAN ANTONIO ALC/MMEDT, KELLY AFB, TEXAS 78241-5990.

Published under authority of the Secretary of the Air Force

30 JUNE 1987

SHORT TITLE: MADARS MULTIPLEXER PROCESSOR CIRCUIT BREAKERS

1. PURPOSE.

To provide coverage for circuit breakers added to multiplexer processor.

2. INSTRUCTIONS.

- (A) Title page is amended to add the words "PARTIALLY VERIFIED".
- (B) Add status page as shown on page 2 of this supplement prior to page i.
- (C) On page 6-23, amend figure 6-5 as shown in figure 1 of this supplement.
- (D) On page 6-25, add new step to paragraph 6-6 as follows:
 - dA. Ensure the NO. 1, NO. 2, and NO. 3 28 VDC MULTIPLEXER PROCESSOR MEMORY circuit breakers on multiplexer processor junction box in bay 3 avionics rack are closed. (See figure 2.)
- (E) On page 6-26, add new step to paragraph 6-7 as follows:
 - hA. Ensure the NO. 1, NO. 2, and NO. 3 28 VDC MULTIPLEXER PROCESSOR MEMORY circuit breakers on multiplexer processor junction box in bay 3 avionics rack are closed. (See figure 2.)
- (F) On page 6-41, add new step to paragraph 6-22 as follows:
 - bA. Open the NO. 1, NO. 2, and NO. 3 28 VDC MULTIPLEXER PROCESSOR MEMORY circuit breakers on multiplexer processor junction box in bay 3 avionics rack. (See figure 2.)

Exhibit 22
As Transmitted

TO LGC-ATM-POCD-1840S-1

OPERATIONAL SUPPLEMENT

OPERATIONAL SUPPLEMENT

TECHNICAL MANUAL

ORGANIZATIONAL MAINTENANCE

INSTRUMENTS

USAF SERIES

C-5A AND C-5B

AIRCRAFT

F33657-82-C-2117

THIS PUBLICATION SUPPLEMENTS T.O. 1C-5A-2-6 DATED 29 MARCH 1985. Reference to this supplement will be made on the title page of the basic publication by personnel responsible for maintaining the publication in current status.

COMMANDERS ARE RESPONSIBLE FOR BRINGING THIS SUPPLEMENT TO THE ATTENTION OF ALL AFFECTED AF PERSONNEL

This publication is required for official use or for administrative or operational purposes only. Distribution is limited to US Government agencies. Other requests for this document must be referred to SAN ANTONIO ALC/MMEDT, KELLY AFB, TEXAS 78241-5990.

Published under authority of the Secretary of the Air Force

30 JUNE 1987

SHORT TITLE: MADARS MULTIPLEXER PROCESSOR CIRCUIT BREAKERS \ PURPOSE.

To provide coverage for circuit breakers added to multiplexer processor. INSTRUCTIONS.

- (A) Title page is amended to add the words "PARTIALLY VERIFIED".
- (B) Add status page as shown on page 2 of this supplement prior to page i.
- (C) On page 6-23, amend figure 6-5 as shown in figure 1 of this supplement.
- (D) On page 6-25, add new step to paragraph 6-6 as follows: dA. Ensure the NO. 1, NO. 2, and NO. 3 28 VDC MULTIPLEXER PROCESSOR MEMORY circuit breakers on multiplexer processor junction box in bay 3 avionics rack are closed. (See figure 2.)
- (E) On page 6-26, add new step to paragraph 6-7 as follows: hA. Ensure the NO. 1, NO. 2, and NO. 3 28 VDC MULTIPLEXER PROCESSOR MEMORY circuit breakers on multiplexer processor junction box in bay 3 avionics rack are closed. (See figure 2.)
- (F) On page 6-41, add new step to paragraph 6-22 as follows: bA. Open the NO. 1, NO. 2, and NO. 3 28 VDC MULTIPLEXER PROCESSOR MEMORY circuit breakers on multiplexer processor junction box in bay 3 avionics rack. (See figure 2.)

OPERATIONAL SUPPLEMENT

1

Exhibit 23

As Published
OPERATIONAL SUPPLEMENT

TECHNICAL MANUAL

ORGANIZATIONAL MAINTENANCE

INSTRUMENTS

USAF SERIES

C-5A AND C-5B

AIRCRAFT

F33657-82-C-2117

THIS PUBLICATION SUPPLEMENTS T.O. 1C-5A-2-6 29 MARCH 1985. Reference to this supplement will be made on the title page of the basic publication by personnel responsible for maintaining the publication in current status.

COMMANDERS ARE RESPONSIBLE FOR BRINGING THIS SUPPLEMENT TO THE ATTENTION OF ALL AFFECTED AF PERSONNEL

This publication is required for official use or for administrative or operational purposes only. Distribution is limited to US Government agencies. Other requests for this document must be referred to SAN ANTONIO ALC/MMEDT, KELLY AFB, TEXAS 78241-5990.

Published under authority of the Secretary of the Air Force

30 JUNE 1987

SHORT TITLE: MADARS MULTIPLEXER PROCESSOR CIRCUIT BREAKERS

1. PURPOSE.

To provide coverage for circuit breakers added to multiplexer processor.

2. INSTRUCTIONS.

- (A) Title page is amended to add the words "PARTIALLY VERIFIED".
- (B) Add status page as shown on page 2 of this supplement prior to page i.
- (C) On page 6-23, amend figure 6-5 as shown in figure 1 of this supplement.
- (D) On page 6-25, add new step to paragraph 6-6 as follows:
 - dA. Ensure the NO. 1, NO. 2, and NO. 3 28 VDC MULTIPLEXER PROCESSOR MEMORY circuit breakers on multiplexer processor junction box in bay 3 avionics rack are closed. (See figure 2.)
- (E) On page 6-26, add new step to paragraph 6-7 as follows:
 - hA. Ensure the NO. 1, NO. 2, and NO. 3 28 VDC MULTIPLEXER PROCESSOR MEMORY circuit breakers on multiplexer processor junction box in bay 3 avionics rack are closed. (See figure 2.)
- (F) On page 6-41, add new step to paragraph 6-22 as follows:
 - bA. Open the NO. 1, NO. 2, and NO. 3 28 VDC MULTIPLEXER PROCESSOR MEMORY circuit breakers on multiplexer processor junction box in bay 3 avionics rack. (See figure 2.)

Exhibit 24
As Transmitted

TO LGC-ATM-POCX-1840S-1

OPERATIONAL SUPPLEMENT

OPERATIONAL SUPPLEMENT

TECHNICAL MANUAL

ORGANIZATIONAL MAINTENANCE

INSTRUMENTS

USAF SERIES

C-5A AND C-5B

AIRCRAFT

F33657-82-C-2117

THIS PUBLICATION SUPPLEMENTS T.O. 1C-5A-2-6 DATED 29 MARCH 1985. Reference to this supplement will be made on the title page of the basic publication by personnel responsible for maintaining the publication in current status.

COMMANDERS ARE RESPONSIBLE FOR BRINGING THIS SUPPLEMENT TO THE ATTENTION OF ALL AFFECTED AF PERSONNEL

This publication is required for official use or for administrative or operational purposes only. Distribution is limited to US Government agencies. Other requests for this document must be referred to SAN ANTONIO ALC/MMEDT, KELLY AFB, TEXAS 78241-5990.

Published under authority of the Secretary of the Air Force

30 JUNE 1987

SHORT TITLE: MADARS MULTIPLEXER PROCESSOR CIRCUIT BREAKERS

1. PURPOSE.

To provide coverage for circuit breakers added to multiplexer processor.

2. INSTRUCTIONS.

- (A) Title page is amended to add the words "PARTIALLY VERIFIED".
- (B) Add status page as shown on page 2 of this supplement prior to page i.
- (C) On page 6-23, amend figure 6-5 as shown in figure 1 of this supplement.
- (D) On page 6-25, add new step to paragraph 6-6 as follows: dA. Ensure the NO. 1, NO. 2, and NO. 3 28 VDC MULTIPLEXER PROCESSOR MEMORY circuit breakers on multiplexer processor junction box in bay 3 avionics rack are closed. (See figure 2.)
- (E) On page 6-26, add new step to paragraph 6-7 as follows: hA. Ensure the NO. 1, NO. 2, and NO. 3 28 VDC MULTIPLEXER PROCESSOR MEMORY circuit breakers on multiplexer processor junction box in bay 3 avionics rack are closed. (See figure 2.)
- (F) On page 6-41, add new step to paragraph 6-22 as follows: bA. Open the NO. 1, NO. 2, and NO. 3 28 VDC MULTIPLEXER PROCESSOR MEMORY circuit breakers on multiplexer processor junction box in bay 3 avionics rack. (See figure 2.)

OPERATIONAL SUPPLEMENT

1

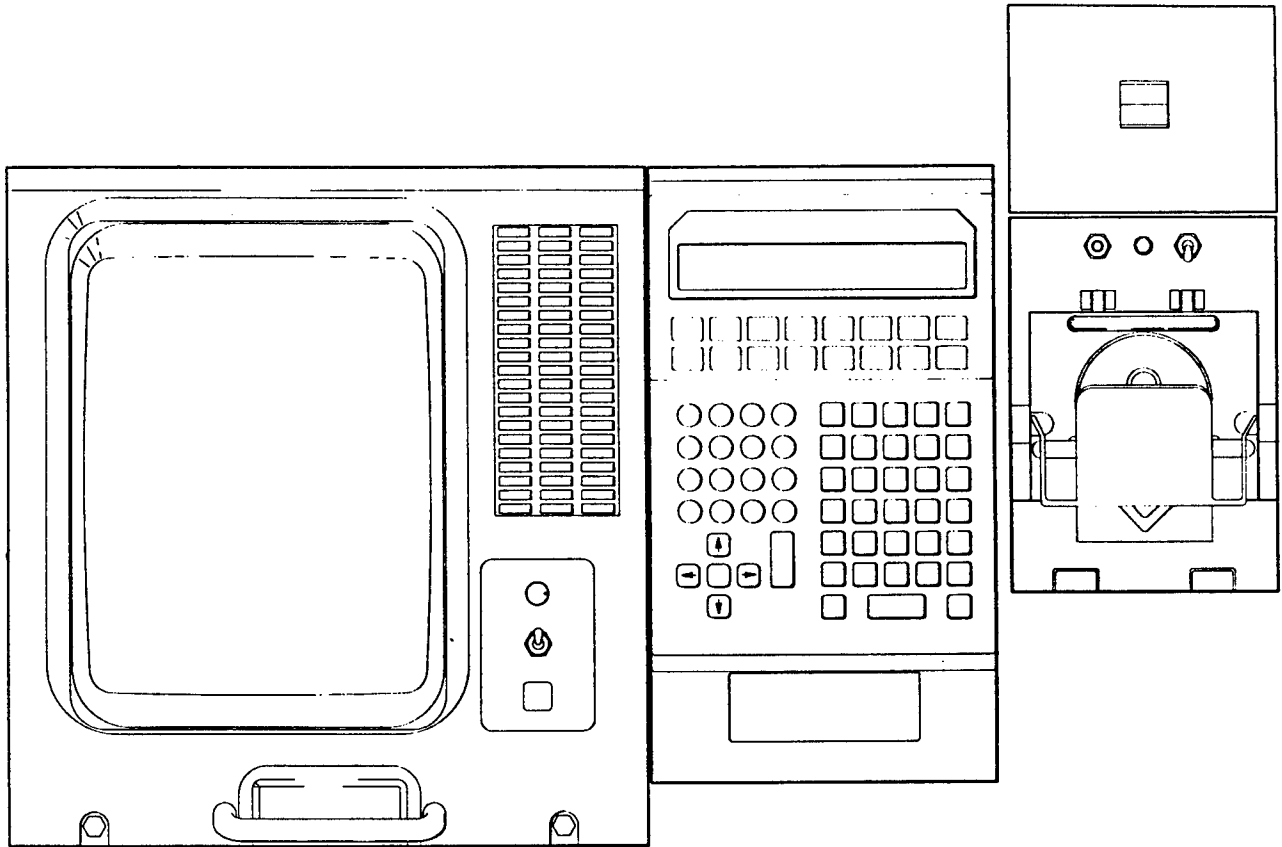

Figure 2-3. MADARS Control Display Group
(Auto-trol GS1000 to Auto-trol GS5000)(ART036)

Exhibit 26
As Transmitted

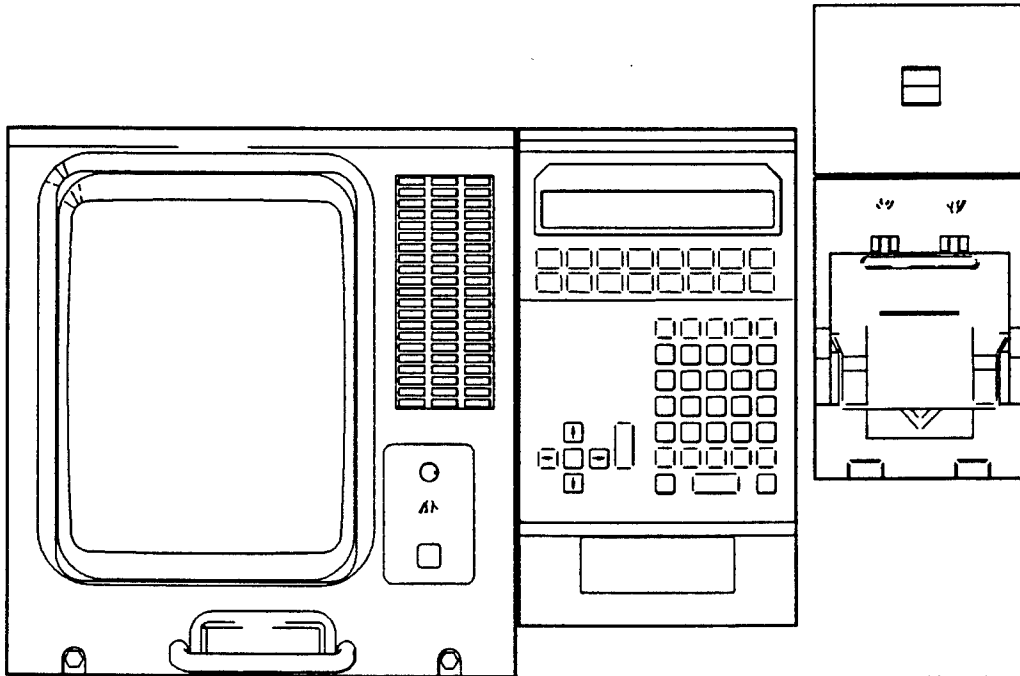
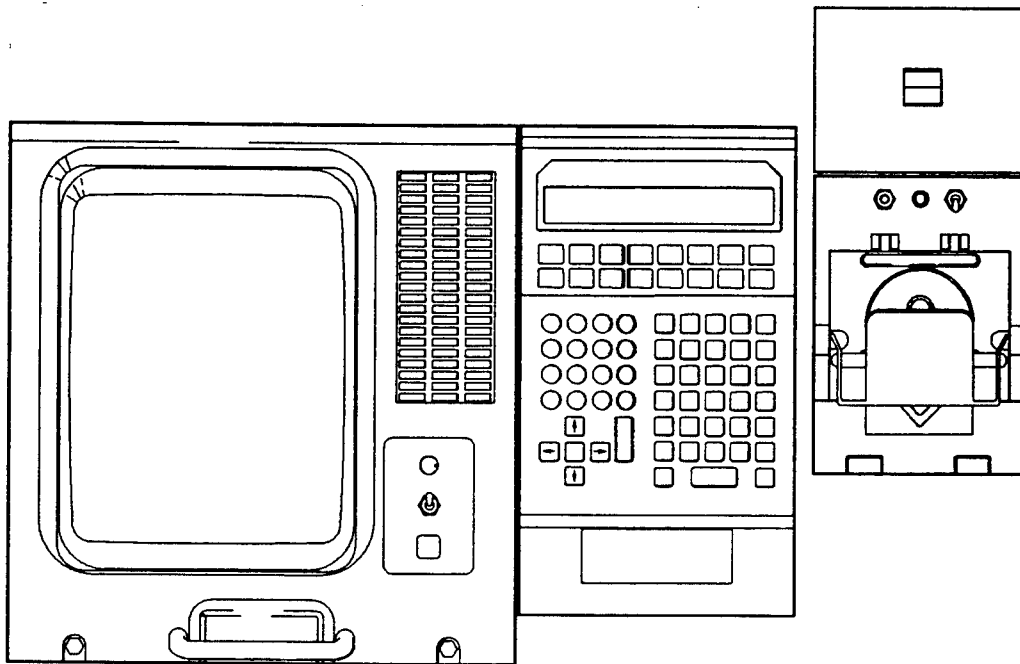
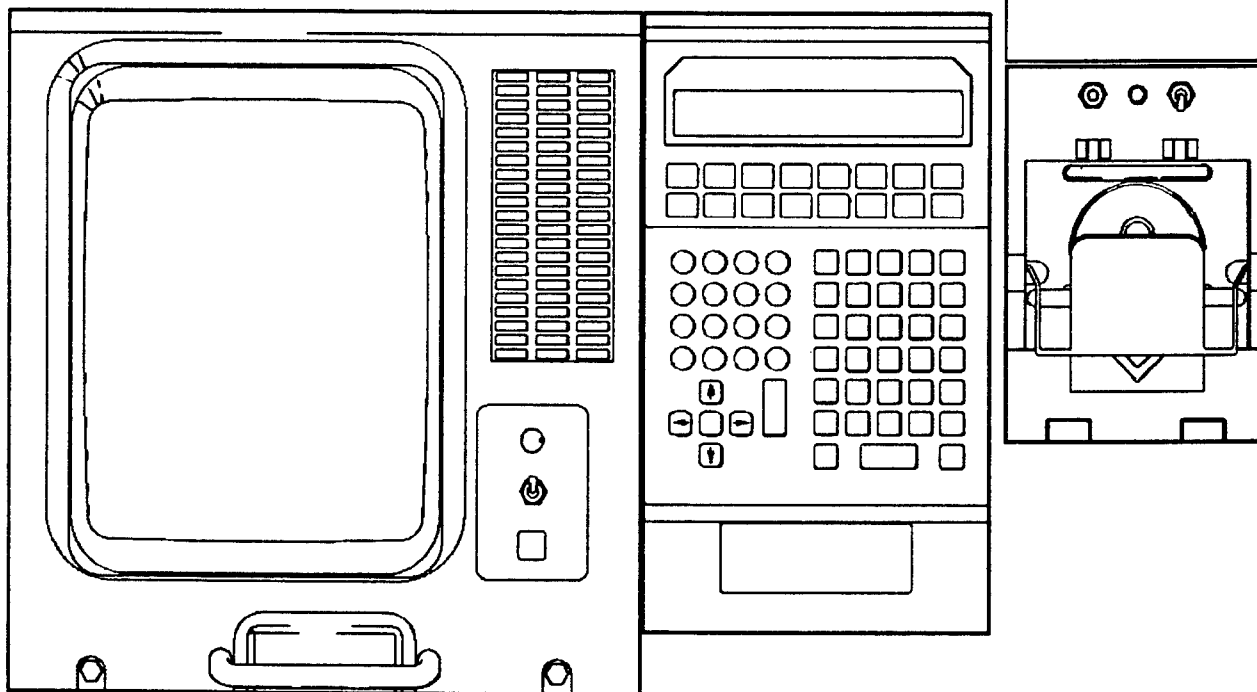

Exhibit 27

As transmitted (IGES/POCX)



As transmitted (IGES/Raster)



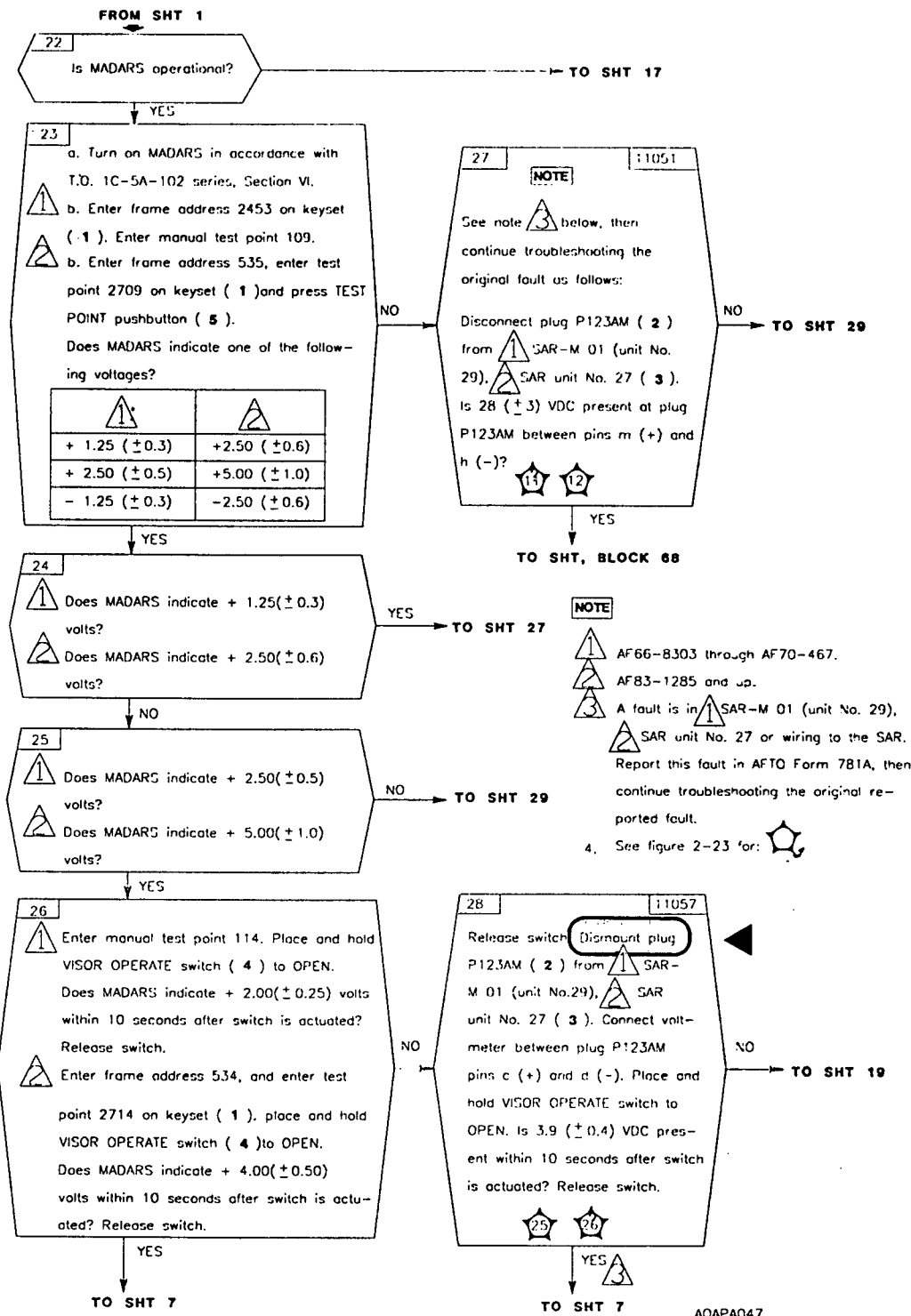
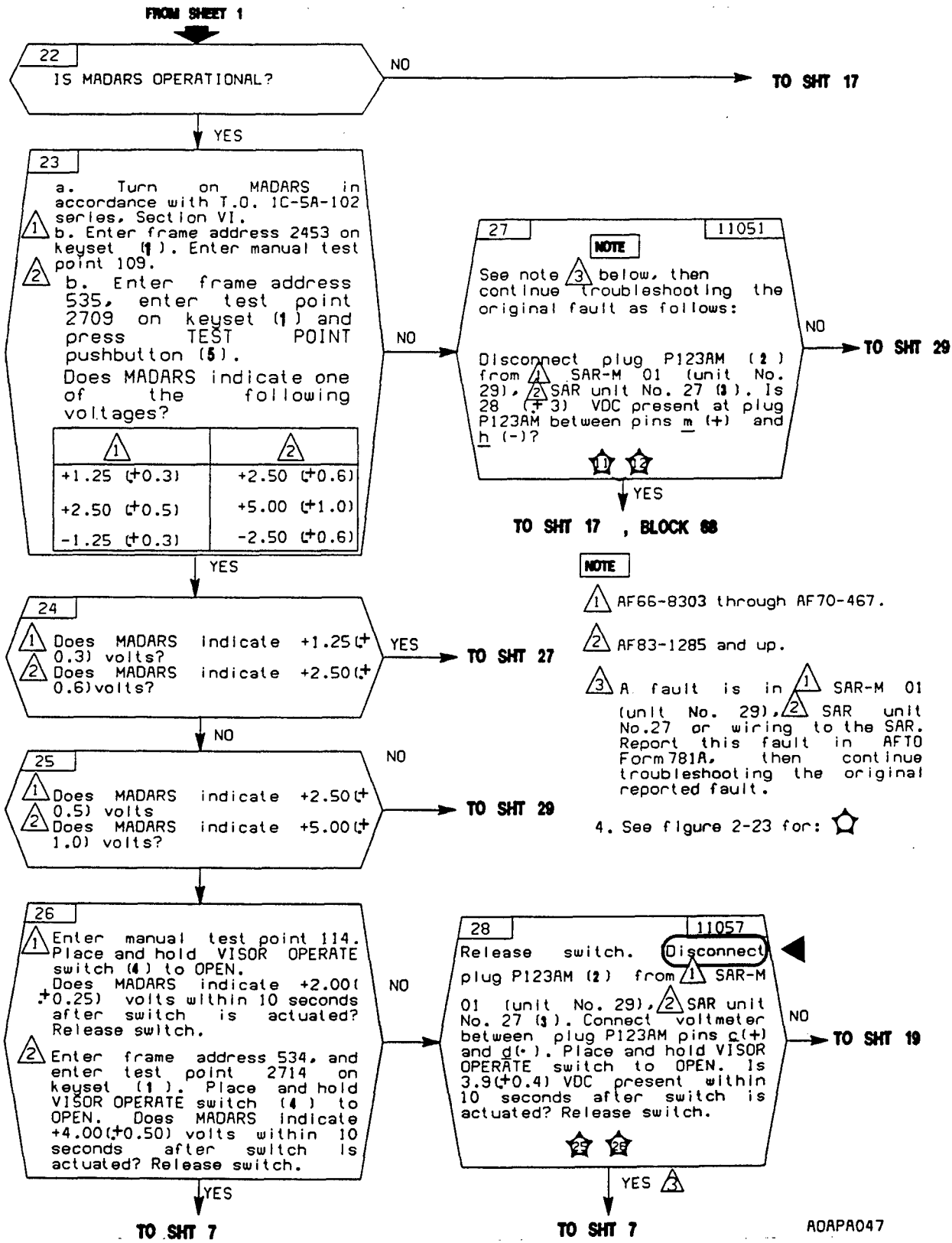

Figure 2-8. Visor Locks Do Not Unlock for Visor Open Sequence (Sheet 1 of 2)
(Drawn) (ART017)

Exhibit 30
As Transmitted



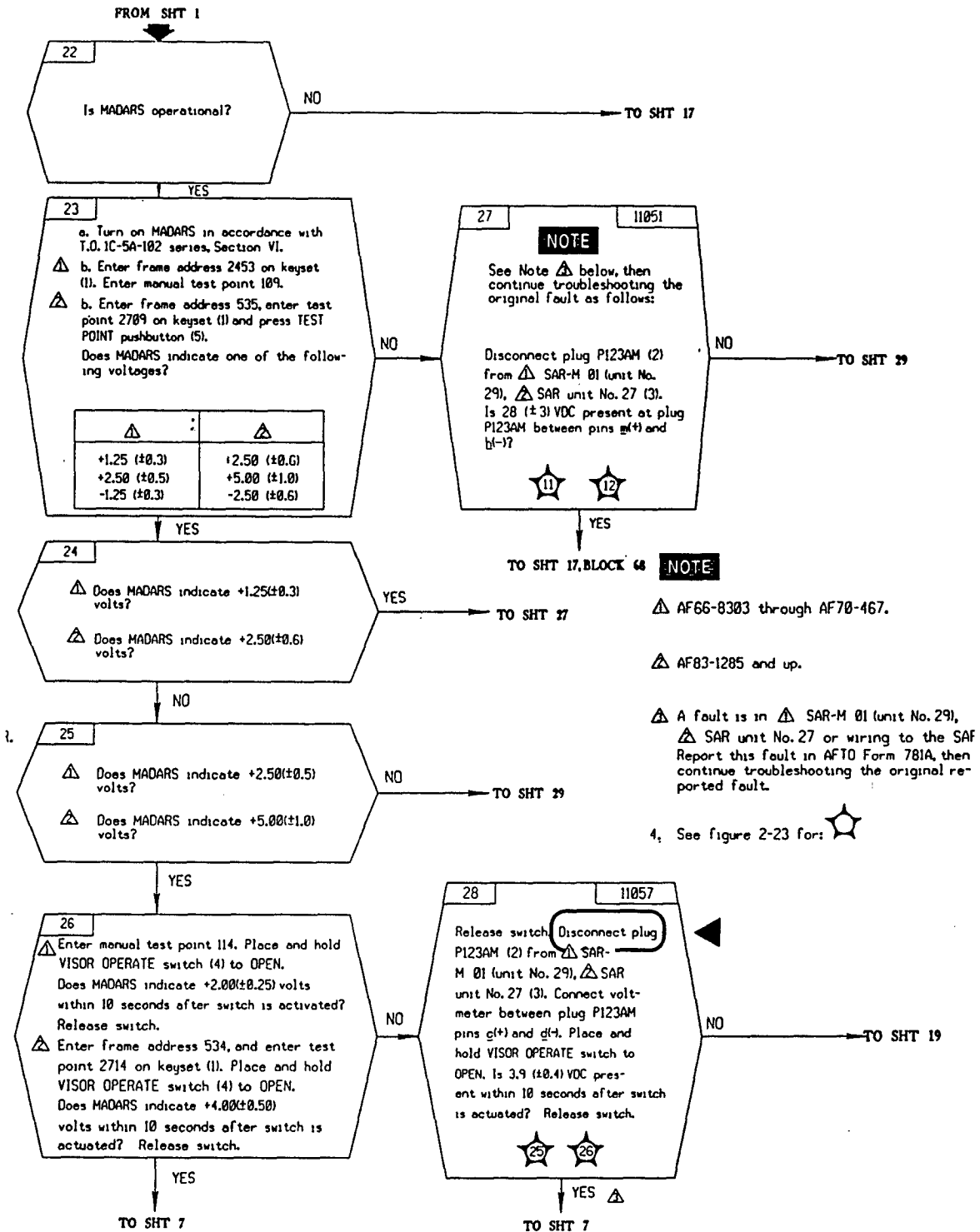
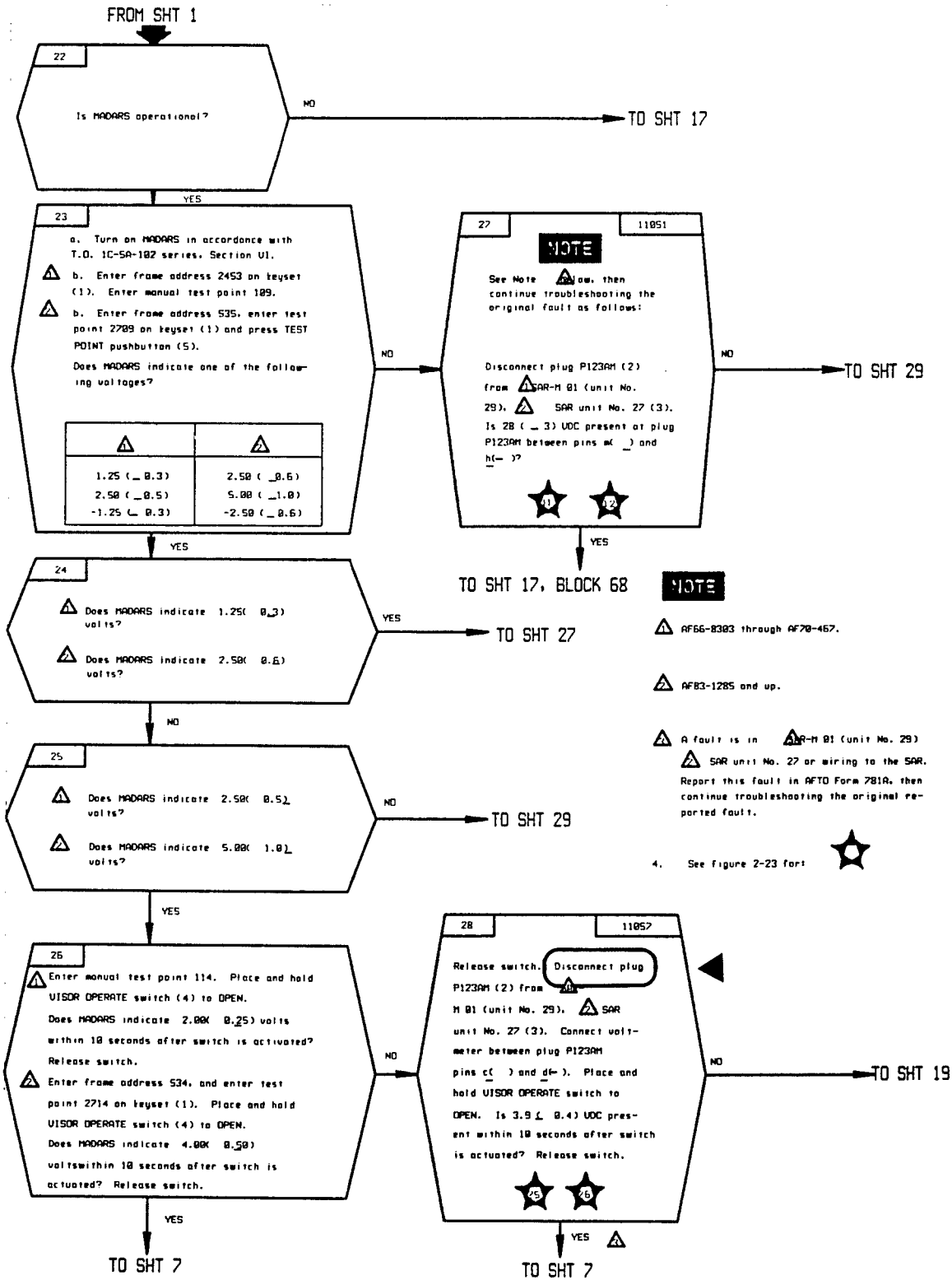

Figure 2-8. Visor Locks Do Not Unlock for Visor Open Sequence (Sheet 1 of 2)
(Drawn)(ART047)

CS-12-12F1-1-11-2-0-009-

Exhibit 32 As Transmitted



CS-(2-12F1-1-1)-2-0-009-5

As Published

SECTION X

ENGINE BUILDUP MANUAL FORMAT

10-1. GENERAL. This section provides representative data from an Engine Buildup manual.

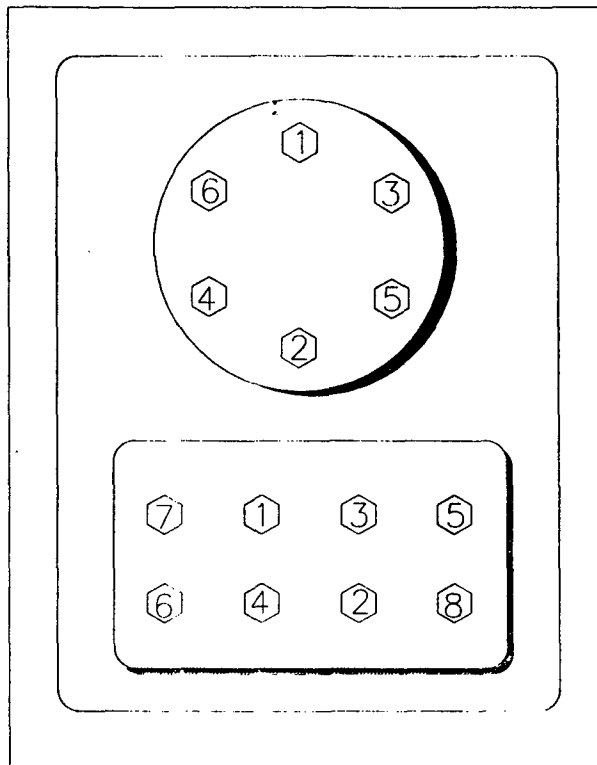

Figure 10-1. Bolt Tightening Sequence
(Drawn)(ART113)

10-2. THREAD ENGAGEMENT CRITERIA. Inspect all internally threaded rods, rod ends, turn-buckles, etc. which are equipped with inspection holes to ensure proper thread engagement. Proper thread engagement is ensured when the threads of the externally threaded component has completely blocked the inspection hole. If the installation is difficult to inspect visually, a piece of wire shall be inserted in the inspection hole to determine if there is sufficient thread engagement to block the hole.

10-3. SPECIAL TOOLS REQUIRED FOR BUILDUP. (See table 2-VII and figure 4-27.) For

illustration of special tools specified in table 2-VII, refer to part number listing in Section V. Adjacent to the part number listing will be the figure and index number of the tool illustration which can then be located in figure 4-25.

10-4. INSTALLATION OF V-BAND COUPLINGS ON PNEUMATIC DUCTS AND COMPONENTS. (See figure 2-4.)

a. The following procedures shall be observed for aligning and clamping bleed air ducts and components, irrespective of whether it is for initial installation of a new duct or reinstallation of an existing duct.

(1) - Lightly coat the inside surface of clamps with grease conforming to Specification MIL-L-25681 prior to each installation.

(2) Check for positive angle bend on sheet metal flanges by placing a gage block across the end of the duct. If flange is flat or has negative angle, reform duct flange in accordance with paragraph titled Reforming of Bleed Duct Flange in this section.

CAUTION

Ensure gap and alignment of clamped joints is within specified tolerance. Failure to comply could cause coupling failure.

(3) The gap and alignment in clamped joints shall be 0.060 inch prior to tightening the V-band coupling nut.

CAUTION

Do not use standard torque values for nuts and bolts when tightening V-band coupling nuts. Refer to specific installation procedures for the V-band being installed. Failure to comply may result in coupling failure.

Exhibit 34

IGES image as transmitted and processed

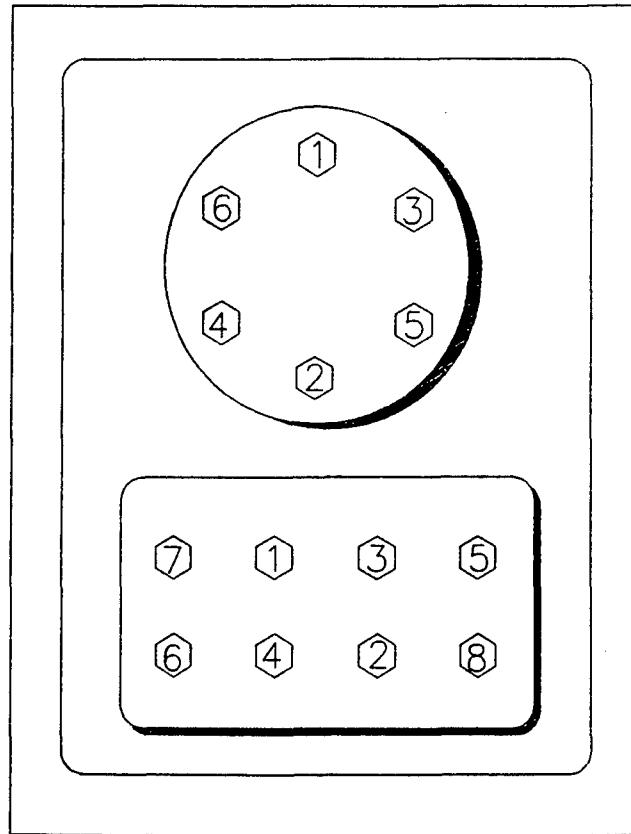

Section X. ENGINE BUILDUP MANUAL FORMAT

10-1. GENERAL. This section provides representative data from an Engine Buildup manual.

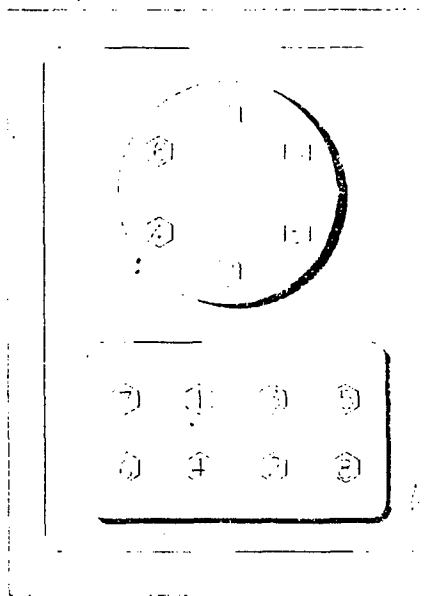

Figure 10-1. Bolt Tightening Sequence
(Drawn)(ART113)

10-2. THREAD ENGAGEMENT CRITERIA. Inspect all internally threaded rods, rod ends, turnbuckles, etc. which are equipped with inspection holes to ensure proper thread engagement. Proper thread engagement is ensured when the threads of the externally threaded component has completely blocked the inspection hole. If the installation is difficult to inspect visually, a piece of wire shall be inserted in the inspection hole to determine if there is sufficient thread engagement to block the hole.

10-3. SPECIAL TOOLS REQUIRED FOR BUILDUP. (See table 2-VII and figure 4-27.) For illustration of special tools specified in table 2-VII, refer to part number listing in Section V. Adjacent to the part number listing will be the figure and index number of the tool illustration which can then be located in figure 4-25.

10-4. INSTALLATION OF V-BAND COUPLINGS ON PNEUMATIC DUCTS AND COMPONENTS. (See figure 2-4.)

a. The following procedures shall be observed for aligning and clamping bleed air ducts and components, irrespective of whether it is for initial installation of a new duct or reinstallation of an existing duct.

(1) Lightly coat the inside surface of clamps with grease conforming to Specification MIL-L-25681 prior to each installation.

(2) Check for positive angle bend on sheet metal flanges by placing a gage block across the end of the duct. If flange is flat or has negative angle, reform duct flange in accordance with paragraph titled Reforming of Bleed Duct Flange in this section.

CAUTION

Ensure gap and alignment of clamped joints is within specified tolerance. Failure to comply could cause coupling failure.

(3) The gap and alignment in clamped joints shall be 0.060 inch prior to tightening the V-band coupling nut.

CAUTION

Do not use standard torque values for nuts and bolts when tightening V-band coupling nuts. Refer to specific installation procedures for the V-band being installed. Failure to comply may result in coupling failure.

CAUTION

Do not attempt to correct leaks by tightening clamp nuts. The flange of the duct shall be checked and, if necessary, reformed as described in paragraph titled Installation of V-Band Couplings on Pneumatic Ducts and Components, step (2). Failure to comply may result in duct joint failure.

CAUTION

Do not use pliers to squeeze coupling ends together. Failure to comply may cause coupling failure.

IGES image as transmitted and processed

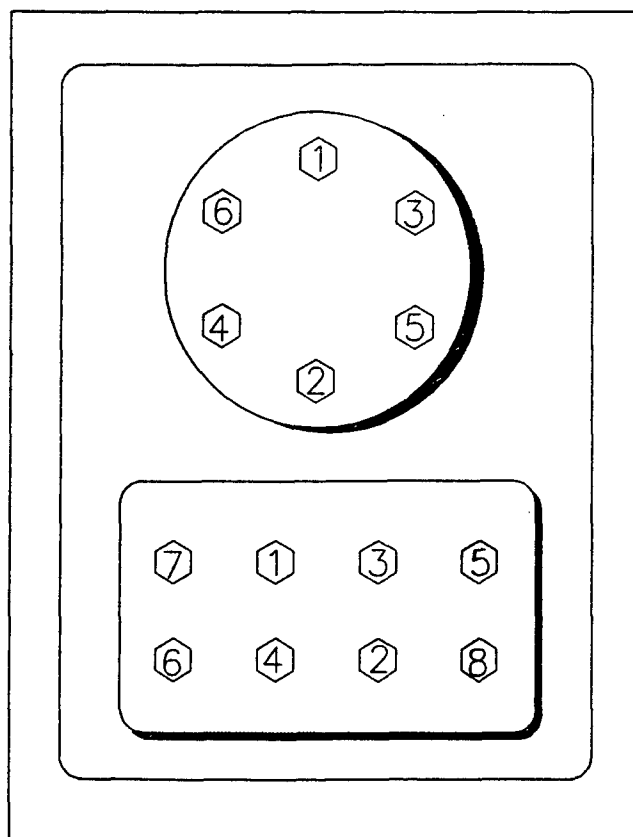
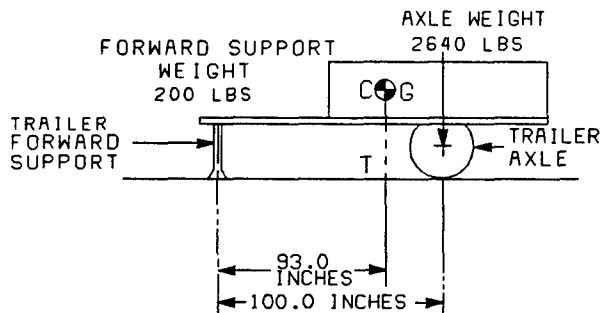

Exhibit 37
Image from IGES file



EXAMPLE PROBLEM:

LOCATE THE CG OF A TRAILER.

TO LOCATE THE CG OF A TRAILER PROCEED AS FOLLOWS:

1. MULTIPLY THE AXLE WEIGHT BY ITS DISTANCE FROM THE FORWARD SUPPORT

$$2640 \times 100 = 264000$$

2. ADD THE WEIGHT OF THE FORWARD SUPPORT (200 LBS) AND THE WEIGHT OF THE AXLE (2640 LBS) TOGETHER

$$200 + 2640 = 2840 \text{ LBS}$$

3. DIVIDE THE RESULT OF STEP 2 (2840 LBS) INTO THE RESULT OF STEP 1 (264000)

$$\frac{264000}{2840} = 93.0 \text{ INCHES}$$

ANSWER TO EXAMPLE PROBLEM = 93.0 INCHES
93.0 INCHES IS THE DISTANCE FROM THE FORWARD TRAILER SUPPORT TO THE TRAILER CG.

ADAPR111

CCITT Group IV file

EXAMPLE PROBLEM:

LOCATE THE CG OF A TRAILER.

TO LOCATE THE CG OF A TRAILER PROCEED AS FOLLOWS:

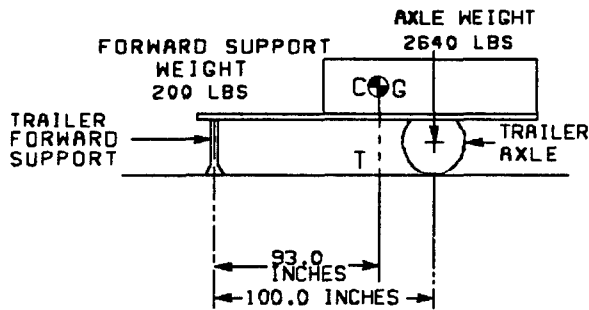

1. MULTIPLY THE AXLE WEIGHT BY ITS DISTANCE FROM THE FORWARD SUPPORT

$$2640 \times 100 = 264000$$

2. ADD THE WEIGHT OF THE FORWARD SUPPORT (200 LBS) AND THE WEIGHT OF THE AXLE (2640 LBS) TOGETHER

$$200 + 2640 = 2840 \text{ LBS}$$

3. DIVIDE THE RESULT OF STEP 2 (2840 LBS) INTO THE RESULT OF STEP 1 (264000)

$$\frac{264000}{2840} = 93.0 \text{ INCHES}$$

ANSWER TO EXAMPLE PROBLEM = 93.0 INCHES
93.0 INCHES IS THE DISTANCE FROM THE FORWARD TRAILER SUPPORT TO THE TRAILER CG.

Raster CCITT Group IV version of Exhibit 36

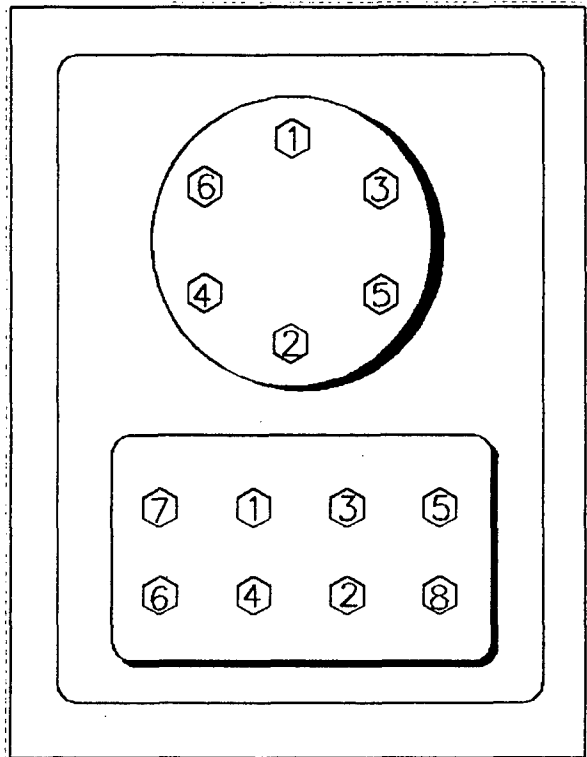

**Raster version of illustrations scanned
and vectorized, but not cleaned up**

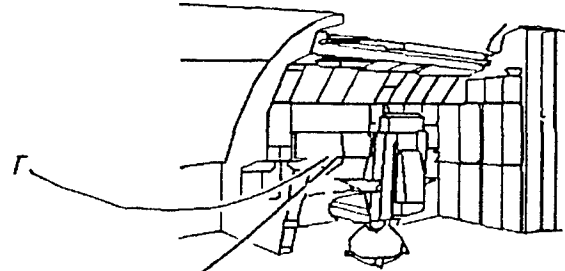
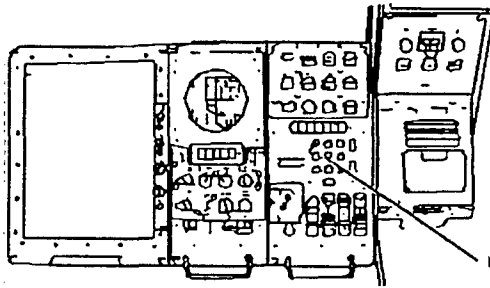

FLIGHT ENGINEER'S STATION

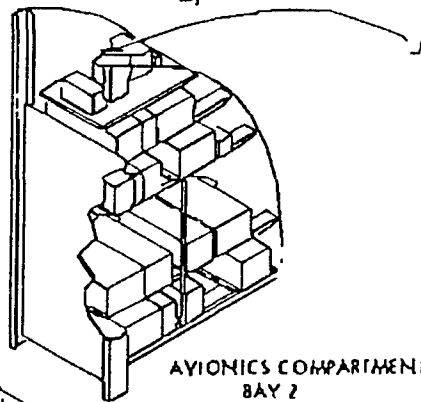
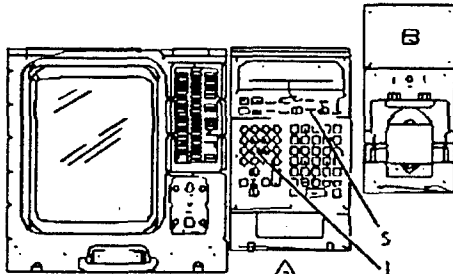

AVIONICS COMPARTMENT
BAY 2

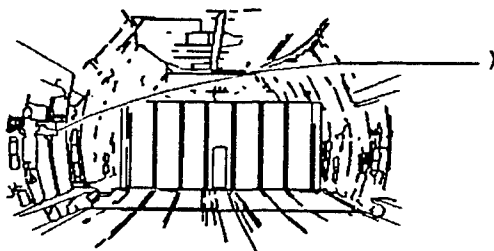
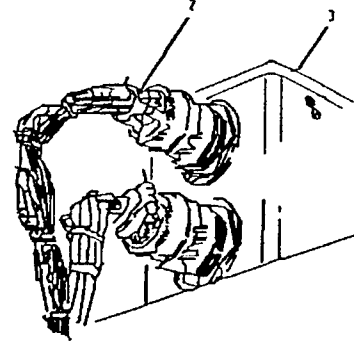

FORWARD CARGO

