

AITI Report
87-003

UCRL 15952 Rev 1
PO 1194803



Prepared for
Lawrence Livermore
National Laboratory
Air Force Logistics Command
AITI Project

Honeywell Technical Order Transfer Tests

June 12, 1987

DTIC QUALITY INSPECTED 4

19960826 102



Lawrence Livermore National Laboratory

DISTRIBUTION STATEMENT A
Approved for public release;
Distribution Unlimited

DISCLAIMER NOTICE



THIS DOCUMENT IS BEST QUALITY AVAILABLE. THE COPY FURNISHED TO DTIC CONTAINED A SIGNIFICANT NUMBER OF PAGES WHICH DO NOT REPRODUCE LEGIBLY.

DISCLAIMER

Work performed under the auspices of the U.S. Department of Energy by Lawrence Livermore National Laboratory under contract number W-7405-ENG-48.

This document was prepared as an account of work sponsored by an agency of the United States Government. Neither the United States Government nor the University of California nor any of their employees, makes any warranty, express or implied, or assumes any legal liability or responsibility for the accuracy, completeness, or usefulness of any information, apparatus, product, or process disclosed, or represents that its use would not infringe privately owned rights. Reference herein to any specific commercial products, process, or service by trade name, trademark, manufacturer, or otherwise, does not necessarily constitute or imply its endorsement, recommendation, or favoring by the United States Government or the University of California. The views and opinions of authors expressed herein do not necessarily state or reflect those of the United States Government or the University of California, and shall not be used for advertising or product endorsement purposes.

Contents

1	Executive Summary	1
2	File Set Preparation and Processing	5
3	Test Results	7
	Problem Numbering	7
	Transmission Envelope	7
	Analysis.....	7
	Statistics.....	8
	Recommendations.....	9
	Text Files	9
	AITI-Ref-1986-1 Analysis	9
	AITI-Ref-1986-1 Statistics	12
	T.O. NAVAIR 03-45BV-6 Analysis	12
	T.O. NAVAIR 03-45BV-6 Statistics	14
	Recommendations	14
	IGES Files	15
	AITI Ref-1986-1 Analysis	15
	T.O. NAVAIR 03-45BV-6 Analysis	15
	T.O. NAVAIR 03-45BV-6Statistics	15
	Recommendations	17
	CITT Files	17
4	Summary of Recommendations	19
	AQC Tools for Text Files	19
	Added SGML Tags	19
	IGES Improvements	19
	MIL-STD-1840A	19
5	Exhibits	21

1 Executive Summary

The AFLC/AITI Standards Project is testing the Military Standard for the Automated Interchange of Technical Information, MIL-STD-1840 (the Standard). The objective of the tests is to demonstrate the validity of the transfer protocol defined in the Standard itself and the viability of standardized formats for the transfer of technical information defined in other specifications used by the Standard.

Two documents (file sets) were prepared by Honeywell for this test. The documents were prepared in accordance with Appendix A of the December 12, 1986, draft revision of the Standard. The file sets, on magnetic tape, were delivered to the ATOS laboratory facility at SYSCON Corporation, San Diego, California for testing. Each file set consisted of a declaration file, SGML tagged text files, and IGES illustration files (for the second document only) written on magnetic tape in accordance with FIPS PUB 79 and the Standard.

The tape format was in complete accordance with FIPS PUB 79. The declaration files were also acceptable, with one error in placement observed.

The text files were successful in meeting the requirements of the USAF SGML tagging scheme, with some errors that were not fatal. The quality could be characterized as fair for a Sending System that regularly uses nearly the same SGML application as ATOS. After making a number of simple corrections, a reasonable reproduction of the original could be generated. The quality was not good enough for a production environment. Lack of automated quality control (AQC) tools could account for the errors.

The illustrations transmitted in IGES format did not match the originally published illustrations due to an assumed error in either the IGES pre- or postprocessor (see Fig. 1). Font problems with IGES reoccurred (IGES-1). In general, this part of the test was a limited success. No illustrations in CCITT group 4 format were transmitted.

The goal of the test was met, even with the deficiencies noted. Based on the results of this test and prior observation, it is recommended that:

1. Certain improvements be made to MIL-STD-1840A (see Summary of Recommendations).
2. Sending systems be provided with AQC tools (see AITI Report 87-002).
3. IGES be improved with respect to text fonts (see AITI Report 87-002).

Figure 1.

The transmitted images (right) in IGES format did not match the published originals (left) due to an assumed error in the IGES pre- or postprocessor.

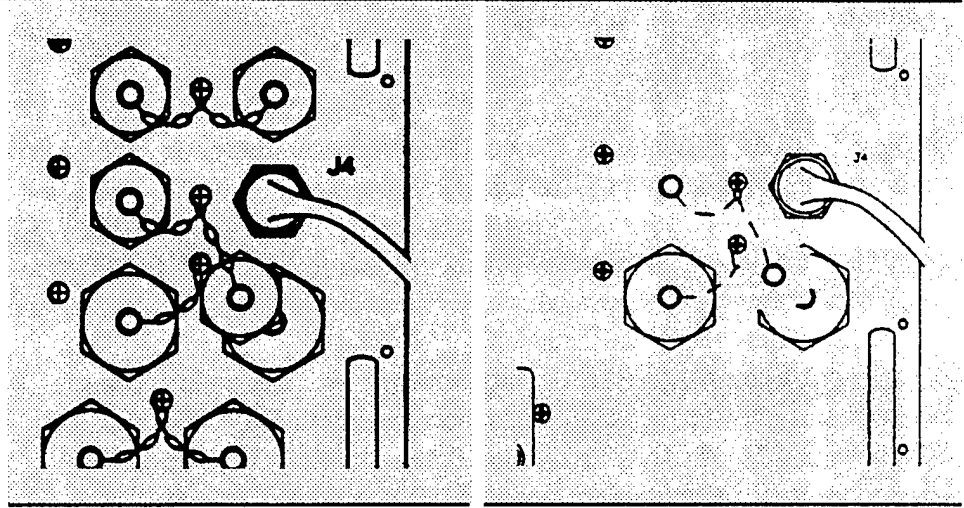

Major Compliance Categories	File Set		Comments
	1	2	
Transmission Envelope			
ANSI Level 3 tape	pass	pass	
MIL-STD-1840 tape	pass	part	Second Doc. Decl. file misplaced
Declaration file	pass	pass	
Header records	part	part	Trailing nulls in IGES headers Upper/lower case differences
SGML			
Correct use	pass	pass	
No minor errors	fail	fail	
No tag typo's	pass	pass	
IGES			
Version 3.0	-	fail	
Parser/Verify	-	part	
Subset compliance	-	pass	Accidental compliance
All good images	-	fail	
CCITT			
All good images	-	-	Preparation for transfer

Honeywell Avionics
Transfer Tests-Summary of
Compliances to MIL-STD-
1840 (12 December 1986).

- pass = compliant in all respects
- part = partial compliance, usable data
- fail = noncompliant, unusable data
- = no graphic data in this form
- * = unreadable tape

Explanation of Table of
 Summary of Compliance to
 MIL-STD-1840 (12 December
 1986).

Major Compliance Categories	Explanation of Category
Transmission Envelope ANSI Level 3 tape MIL-STD-1840 tape Declaration file Header records	The "wrapper" around the documents The tape complies with FIPS PUB 79 The tape complies with specific MIL-STD-1840 req'ments The Document Declaration files are correct The Header records for each data file are correct
SGML Correct use Required tags present Tags keyed correctly	SGML tagged text files The source system personnel under- stand SGML broadly All required tags are present All tags are keyed correctly
IGES V 3.0 Parser/Verify Subset compliance All good images	Illustrations in IGES format The files are in conformance with Version 3.0 The file passes the parser/verifier without serious error The files comply with MIL-STD-1840 IGES subset req'ments The IGES postprocessor produced an accurate image
CCITT All good images	Illustrations in CCITT Raster format Usable images can be derived from the data

- pass = compliant in all respects
 part = partial compliance, usable data
 fail = noncompliant, unusable data
 - = no graphic data in this form
 * = unreadable tape

2 File Set Preparation and Processing

The transmission tape was written at Honeywell, St. Louis Park, Minnesota, on a VAX. The text files were prepared (tagged) on the same system, presumably. The IGES illustrations were generated on an Auto-CAD system. The files were converted to IGES and transferred to the VAX by unspecified means.

Two documents were prepared by Honeywell for this test. The first document was the AITI Reference T.O. 86-1. The second was NAVAIR 03-45BV-6, Overhaul Instructions with Illustrated Parts Breakdown, Standard Control Panel A02VS110-1. The documents were prepared in accordance with Appendix A of the December 12, 1986, version of the Standard.

The file sets, on magnetic tape, were delivered to the ATOS laboratory facility at SYSCON Corporation, San Diego, California, for testing. The initial tape processing and the majority of the testing were performed on a VAX. An Auto-trol AGW 70 was used to convert the IGES files to a CAD format and subsequently to a plotter format. The plotter files were then converted to a form acceptable to the QMS laser printer. Text hardcopy was output on the same printer.

Appended to the body of the report are paired exhibits of pages from both documents in their as-published form and in the as-transmitted and processed form.

The file sets were processed in the ATOS laboratory with a combination of specially built and commercially available software. Each file set consisted of a declaration file and SGML tagged text files. The first document contained no illustration files. The second document contained IGES illustration files, but no raster images in CCITT group 4 format. Both file sets were written on magnetic tape in accordance with FIPS PUB 79 and the protocol specified in the Standard.

3 Test Results

The test results for the transmission envelope are presented first. Following that, the results for both documents are presented for the SGML text files and the IGES illustration files.

Problem Numbering

In order to avoid repetitious statement of recurring problems encountered during the preceding year of testing, certain problems will be identified by numbering them according to the standard involved and the order of occurrence: for example, IGES-1 or SGML-3. When the same problem is encountered in a submission from a different sending system, it will be referred to by that number. These numbered problems will include only difficulties or deficiencies inherent in the Standard or the specifications on which the Standard calls. Problems attributable to preparation by the sending system or by vendor-supplied hardware/software will be identified separately and specifically.

Transmission Envelope

Analysis

The document transmission envelope consists of the tape and file labels (found "in" the magnetic tape), the document declaration files, and the header records for the text and illustration files. The envelope created by Honeywell had two significant flaws and one minor anomaly. The significant flaws were:

- a. The Document Declaration file for the second document was not placed at the beginning of the tape as specified in the Standard.
- b. The header records for the IGES illustration files had a series of null bytes after the data for each header record.

The purpose of the requirement in the Standard for placing all Document Declaration files at the beginning of the tape is to provide the Destination System with an index or table of contents of the transmission. With foreknowledge of the contents of the transmission, the Destination system can account for each element of each document as it is encountered in the

transmission and determine, when the end of the transmission is reached, if the header records and file counts match what was specified in the Declaration files. Without this foreknowledge, the header records matches and file counts must be reconstructed after the fact, with noticeably greater operator effort and software complexity. Experience during this test program confirms the utility of this requirement.

The null characters used to fill the header records in the IGES files were unexpected. The Standard does not specify what characters are to be used for padding fixed length records or tape blocks. The unused portions of IGES Start and Directory records are padded with blanks, and it was expected that the added header records would be padded in the same way.

The minor anomaly had to do with the difference in upper/lower case usage between the records in the first Document Declaration file and the header records for the text file for the first document. This difference would not confuse a human operator, although it might cause a useless error message from intake processing software.

Statistics

The transmission contained two documents. The first document contained one text file, and no illustration files. The second document contained one text file, and three IGES files. Table 1 below summarizes the statistics on file sizes.

Table 1.
File Size Statistics (in bytes)

	AITI-Ref-1986-1	T.O. NAVAIR 03-45BV-6
23Declaration File	232	
Text Files		
T00*S0001.	44,010	34,548
Totals	44,010	34,548
IGES Files		
F002Q0001.	NA	37,840
F002Q0002.	NA	229,840
F002Q0003.	NA	114,080
Totals	NA	381,760
Grand Total	44,242	416,546

Recommendations

There are two occasions where padding characters are called for. In the first case, fixed length (ANSI type F) records must be padded to the designated length. Writers and readers of MIL-STD-1840 should be able to assume that the specification for the data format (e.g., IGES) defines what padding characters are to be used.

In the second case, the last block of a file usually will require padding characters. The Standard should define the padding characters to be used in this circumstance (1840A-3).

Text Files

AITI-Ref-1986-1 Analysis

The text of the document was transmitted in one file. The list of effective pages (LEP) and the Table of Contents (TOC) were not composed on ATOS. ATOS automatically generates these elements of the document. The LEP and TOC data were, however, subjected to all other phases of the testing.

The printed original document (AITI RefT.O. 86-1) was produced in the ATOS laboratory at SYSCON, San Diego, using SGML tags. In general terms, the purpose of this part of the validation test is to determine if a given application of SGML can adequately support the goals of the CALS policy as implemented by MIL-STD-1840. In a more specific sense, the purpose of this test was to discover if a printed document of known tagging characteristics (at the destination system) could be closely approximated in appearance and structure by the tags used by the sending system. This is intended as a test of the capability of a given application of SGML, not as a test of the expertise of the SGML coders at the sending system. The reader is asked to keep the distinction in mind since it is inevitable that the two issues become intertwined when test results are reported.

The general quality of the tagging by the sending system should be evaluated by noting that Honeywell uses an SGML application nearly identical to that used by the ATOS system. There were a few tagging errors discovered. Each of the tagging errors discovered was repaired and a comment line inserted in the text file noting what repair had been made. In the listing of the file "honey61.txt," these comment lines begin with the string "[co." This string, and any characters following it on the same line, is accepted by the ATOS text composition software as a comment and is

not processed into the final output. After the fixes were applied, the files were resubmitted to the error check process.

The tagging errors were:

- a. The tag <front> was missing
- b. There was no <page ... > tag after the </lep> tag
- c. There were no </section> tags at the end of any of the sections
- d. In the tag (invalid) <pi type=...> the attribute "ltu" was changed to "lt" in 12 instances.

ATOS accepts the tag <pi type=lt> and sets "<" in its place. It is not known if the use of "ltu" versus "lt" is correct in the Sending System. Once again, that absence of a simple lexical scanning and parsing software tool permitted these obvious errors to slip through.

In addition to the tagging errors, the characters "[" and "]" were changed to "{" and "}" because the square brackets are used as native markup delimiters in the ATOS text composition system. If the Sending system had not used the invalid tag <pi type=...> the characters "<" and ">" would also have to have been changed to something else. Use of this invalid tag was also noted in AITI Report 87-002. Both of the above changes were required because there is no provision for a meta language transition or escape sequence in this application of SGML. The currently proposed application of SGML (DOD-M-(SGML) approaches this problem by using PI (processing instructions). This writer does not consider the proposed solution at all satisfactory. This problem is assigned the label SGML-1.

Not listed as discrepancies are the change version of the pages in the LEP and the lack of change bars. The Honeywell text files were coded with change bars. The ATOS job setup to compose the text treated the input files as a "no change" document, thus the lack of change bars, etc.

The difference in appearance of the cover pages led to a short investigation and the following minor revelation. The tagging of several items in the document differed even though the Sending System was using virtually the same SGML application and implementation (provided by the same vendor that supplies ATOS). See Exhibits 1 and 2.

The input data (to composition) of the cover page text and tags are presented side by side below. Some of the text lines have been truncated

to permit side-by-side display. The column on the left is taken from the document as transmitted, while the column on the right is taken from the original AITI Reference Document.

<titlepg>	<titlepg>
<pubno>AITI-Ref-1986-1	<pubno>AITI-Ref-1986-1
<title>Test Plan	<pubid>Test Plan
<Nomen>Validation Test Plan for MIL-STD-1840 (USAF) AUTOMATED INTERCHANGE OF TECHNICAL INFORMATION	<title>Validation Test Plan for MIL-STD-1840 (USAF) Automated Interchange of Technical Information
<mfr>SYSCON CORPORATION LAWRENCE LIVERMORE NATIONAL	<mfr>SYSCON CORPORATION <contrno>Lawrence Livermore National
<contrno>Subcontract 8014805	Subcontract 8914805
<notice>Distribution will be	<notice type=b>Distribution will be
<basedate>1986 OCTOBER 24	<basedate> 1986 October 24
<chgdate>1986 December 15	<chgdate> 1986 December 15
</titlepg>	</titlepg>

Note the different usage of the following tags: title, pubid, nomen (invalid use), contrno, and notice. The missing tag, <pubid>, is a required tag. The tag <nomen> was used in an invalid manner. The ATOS composition software did not note that the <pubid> tag was missing or that the <nomen> tag was used improperly. The AITI lexical scanner (still in its early stages) did note that the tag <nomen> was out of context.

Other differences in appearance were noted. In summary, the only pages that contained blocks of text that seemed identical in appearance were pages 2-1, 3-1, 5-1, and 5-7. Pages 5-2 through 5-6 contain only full-page illustrations with the figure title set underneath. See Exhibits 3 through 6.

Table 5-1 differed only slightly from the original. The difficulties with the table were less than expected, but nevertheless very obvious. As noted in AITI Report 87-002, the application of SGML used for this test has been greatly revised with respect to table tagging in DOD-M-(SGML). See Exhibits 7a, 8, and 7b.

No spelling errors were detected. One text omission and one typo found in the ASCII files were also found in the text file submitted by Honeywell. It is assumed that Honeywell made use of the ASCII files supplied to them containing the text (without tags) of the AITI Reference Document.

It seems, even under the best of circumstances, that dependence on appearance can be misleading and unreliable for some of the purposes that MIL-STD-1840 is intended to serve. The three chief purposes, listed below, were recently confirmed by a DOD representative of the CALS program.

- a. Storage and distribution of technical information to end users, often in a format that parallels the paper presentation of the information
- b. Conservation and updating of that same information
- c. Database support for direct search or expert systems applications over and above the two prior objectives

The first objective might be met by the document if corrected (not as transmitted) in this case. There is definite doubt as to whether the second objective can be met. A document not properly tagged will be harder to maintain than one that is properly tagged. The third objective will definitely not be met by the document as transmitted. In this case, if an analyst were to look in a database of documents for test plans, a direct search on <pubid> will fail because the tag does not exist in the document as transmitted. An expert system might be able to include this document in a search if the <pubno> and <title> tags are used (an increased use of analyst and computer resources).

AITI-Ref-1986-1 Statistics

All of the tagged text for the document was contained in one file, T001S0001. The file contained 44,010 bytes, of which 455 tags used 3393 bytes. The statistics do not include the "[co]" comment lines used to record fixes to the text files.

T.O. NAVAIR 03-45BV-6 Analysis

The text of the document was transmitted in one file. The list of effective pages (LEP) and the Table of Contents (TOC) were not composed on ATOS. ATOS automatically generates these elements of the document. The LEP and TOC data were, however, subjected to all other phases of the testing.

The printed original document (AITI RefT.O. 86-1) was produced in the ATOS laboratory at SYSCON, San Diego, using SGML tags. In general terms, the purpose of this part of the validation test is to determine

if a given application of SGML can adequately support the goals of the CALS policy as implemented by MIL-STD-1840. In a more specific sense, the purpose of this test was to discover if a printed document of known tagging characteristics (at the destination system) could be closely approximated in appearance and structure by the tags used by the sending system. This is intended as a test of the capability of a given application of SGML, not as a test of the expertise of the SGML coders at the sending system. The reader is asked to keep the distinction in mind since it is inevitable that the two issues become intertwined when test results are reported.

The printed copy of this document and the text file did not contain all of the document as indicated in the list of effective pages and the table of contents. Sections 5, 6, and the indices and foldout sections were omitted. This is consistent with the submission of this same document for the 1986 small sample tests.

The document was composed initially using the ATOS default format: revision A of MIL-M-38784. This proved to be the wrong format for this document, although it was the right format for the first document in the transmission. It was recomposed using the format for the B revision, and the appearance and paragraph numbering were at least acceptable.

There is no provision in the Declaration File records for designating the military specification, revision and change level, or other output specification that is the intended format for the document. Noting this in conjunction with recent NSIA review discussions on the A revision to MIL-STD-1840, it would appear that a record should be added to the Declaration file that specifies the Output Specification to be used with the SGML application tags in the text file. This problem is assigned the label 1840A-2.

The ubiquitous "<pi type=...>" tag appeared again. The nine instances of this invalid tag were left intact in order to permit the document to compose readably. The motivations for its use were clearly the same as for the first document in the transmission.

In three cases the <figure...> tag lacked the required attribute "graphic=". This is remarkable in that all the other instances of the <figure> tag did have the required "graphic=" attribute. The ATOS text composition system here is supposedly the same as that at Honeywell, but will not accept a <figure> tag without the required attribute. The laboratory preprocessing software detected the errors and inserted the missing attribute.

Some minor differences in composition parameters between the sending system and the destination system format files resulted in a creeping forward flow of text throughout section 4 of the document. Occasionally the text flow gets back into synchronization, but this is pure coincidence deriving from the differences in space used by the tables in that section.

In posing the question, "If each page were composed separately using the page break tags required by the Standard, would the pages then match as to text content?," it was discovered that the page break tags did not match the page breaks in the printed document as supplied with the digital data. There is no obvious explanation for this discrepancy. The page breaks in other sections of this document and the other document transmitted were correct.

The original and still the only motivation for requiring the page break tags (not defined in the DTD and not implemented by ATOS) was to allow the destination system to compose displayable images that matched, word for word on each page, the paper images of the same document that had supposedly already been distributed. This idea also gives recognition to the fact that we will not achieve a "paperless" condition in this century, and that users of the original printed version will be comparing notes with users of the images (paper or electronic) produced by the destination system. Variances in these images, often side by side, can only lead to a state of doubt in the minds of the two sets of users. Doubt leads to wasted time. On the other hand, failure to note obvious differences in documents can also lead to error in using the wrong document version.

This problem is seemingly intractable. Even in the case where the document is not printed by conventional methods and distributed, but is composed and distributed by both the sending system and the destination system, there is no guarantee that the images from the two sources will match to a degree that will preclude uncertainty in the minds of the users. See Exhibits 9 through 12.

T.O. NAVAIR 03-45BV-6 Statistics

All of the tagged text for the document was contained in one file, T002S0001. The file contained 34,548 bytes, of which 450 tags used 2810 bytes. The statistics do not include the "[co]" comment lines used to record fixes to the text files.

Recommendations

Several conclusions can be reached at this point from the analysis of this document:

- a. The DTD (SGML application) for technical information needs to define tags for comments and for escaping from lexical rules in order to use characters which are otherwise reserved as tag delimiters (SGML-1).

- b. Quality Assurance problems arose during this test which were more subtle than those previously observed (misuse of the <nomen> tag). A full blown parser is the only protection against this sort of error. As noted in AITI Report 87-002, it seems to be time to deemphasize acceptance of text files based on their appearance after composition and printing in favor of a more rigorous and reliable tag analysis software.

IGES Files

AITI-Ref-1986-1 Analysis

No illustrations were provided with this document, although the original did contain numerous illustrations.

T.O. NAVAIR 03-45BV-6 Analysis

The three illustrations provided in this file set all suffered from assumed translation errors to a degree that made them unacceptable. It cannot be determined from the data on hand if the errors were introduced by the IGES preprocessor or the postprocessor. There are indications from the IGES Data Analysis processing log files that the problem may be with the preprocessor. See Exhibits 13 through 18.

To the extent that the illustrations could be converted to hardcopy, the difficulty with type fonts made its reappearance. This problem was labelled IGES-1 and described at length in AITI Report 87-002.

The objection to forcing entities to level zero was also present in this group of illustrations. This problem was labeled 1840A-1 and described at length in AITI Report 87-002.

T.O. NAVAIR 03-45BV-6 Statistics

The statistics tabulated below were compiled from the output generated by laboratory software developed for this test program.

Table 2 presents data on the number of records in the file for each illustration. The three illustrations in this document required 4,734 records and 0.38 million bytes for transmission in IGES uncompressed ASCII format.

Table 2.
 Number of Records per
 IGES File Section

Doc File	Section					T	Total	Avg. Byte
	S	G	D	P				
002 0001	2	3	282	179		1	467	264
002 0002	2	3	1590	1271		1	2867	288
002 0003	2	3	766	648		1	1420	296
Total	6	9	2638	2098		3	4754	283

Table 3 presents data on the count of entity types shown by the level to which the entity was assigned. The data are presented in two forms, or subtables. The first subtable shows, for each file (0001-0003) and for all files, the number of entities by type and level. The second subtable summarizes, for each file and for all files, the number of entities for each level.

Table 3.
 IGES Entity and by Level

Entity	Lvl	File Number			Total
		0001	0002	0003	
100	1	0	1	0	1
100	2	25	205	53	283
100	3	0	4	2	6
110	1	0	0	135	135
110	2	90	474	6	570
110	3	4	13	14	31
124	2	0	37	0	37
212	2	20	14	118	152
308	0	1	7	27	35
408	1	1	0	0	1
408	2	0	40	28	68
Total		141	795	383	1319

Lvl	File Number			Total
	0001	0002	0003	
0	1	7	27	35
1	1	1	135	137
2	135	770	205	1110
3	4	17	16	37
Total	141	795	383	1319

Recommendations

No additional recommendations can be provided based on this test other than those already stated in AITI Report 87-002 regarding the use of IGES.

CCITT Files

No illustrations in raster form (CCITT group 4) were transmitted.

4 Summary of Recommendations

AQC Tools For Text Files.

It is again recommended that sending systems be provided with AQC tools and improved reference documentation to assist preparers of SGML text files. Quality Assurance problems arose during this test which were more subtle than those previously observed (e.g., misuse of the <nomen> tag). As noted in AITI Report 87-002, it seems to be time to deemphasize acceptance of text files based on their appearance after composition and printing in favor of a more rigorous and reliable tag analysis software. See AITI Report 87-002 for a full explanation of this recommendation.

Added SGML Tags

The DTD (SGML application) for technical information needs to define tags for comments and for escaping from lexical rules in order to use characters which are otherwise reserved as tag delimiters (SGML-1)

IGES Improvements

It is recommended that the capability of IGES be expanded to include the parameterized definition of several fonts (IGES-1). See AITI Report 87-002 for a full explanation of this recommendation.

MIL-STD-1840A

It is recommended that the restriction imposed by MIL-STD-1840A on the level assignment for IGES entities be dropped entirely (1840A-1). See AITI Report 87-002 for a full explanation of this recommendation.

It is recommended that a record be added to the Declaration File that specifies the Output Specification to be used with the SGML application tags in the text file (1840A-2).

It is recommended that the Standard define what padding characters are to be used for logical records and tape blocks in those instances where another standard does not provide definite guidance (1840A-3).

5 Exhibits

Exhibits 1 through 18 follow this page. The table that follows numbers and describes the exhibits.

Publication Number, Abbreviated Title, and List of Exhibit Pages		
---	--	--

Table 4.
Exhibits

Cover	Exhibit 1	As published
	Exhibit 2	As transmitted and processed
Text page	Exhibit 3	As published
	Exhibit 4	As transmitted and processed
Text page	Exhibit 5	As published
	Exhibit 6	As transmitted and processed
Text (table)	Exhibit 7a	As published
	Exhibit 8	As transmitted and processed
	Exhibit 7b	As published

T.O. NAVAIR 03-45BV-6 Overhaul Instructions ... Control Panel		
--	--	--

Cover	Exhibit 9	As published
	Exhibit 10	As transmitted and processed
Page	Exhibit 11	As published
	Exhibit 12	As transmitted and processed
Page, (illus)	Exhibit 13	As published
	Exhibit 14	As transmitted and processed
Page, (illus)	Exhibit 15	As published
	Exhibit 16	As transmitted and processed
Page, (illus)	Exhibit 17	As published
	Exhibit 18	As transmitted and processed

AITHRef-1986-1

Test Plan

**VALIDATION TEST PLAN FOR
MIL-STD-1840 (USAF)
AUTOMATED INTERCHANGE OF
TECHNICAL INFORMATION**

**SYSCON CORPORATION
LAWRENCE LIVERMORE NATIONAL LABORATORY
Subcontract 8914805**

Distribution will be made by Lawrence Livermore National Laboratory

1986 OCTOBER 24
22 **CHANGE 1 - 1986 December 15**

TECHNICAL MANUAL

TEST PLAN

**VALIDATION TEST PLAN FOR
MIL-STD-1840 (USAF)
AUTOMATED INTERCHANGE OF
TECHNICAL INFORMATION**

**SYSCON CORPORATION
LAWRENCE LIVERMORE NATIONAL LABORATORY
SUBCONTRACT 8014805**

Distribution will be made by Lawrence Livermore National Laboratory

SECTION I

GENERAL

1-1. PURPOSE OF THE TEST PLAN. The Test Plan for verifying the validity and completeness of the body and the Technical Publication Application appendix of the MIL-STD-1840 (USAF) Automated Interchange of Technical Information (the Standard) has been prepared to fulfill the following objectives:

- To provide guidance for the management and technical effort necessary throughout the test period.
- To establish a comprehensive test plan and to communicate to the sponsor the nature and extent of the tests deemed necessary to provide a basis for evaluation of the Standard.
- To coordinate with the sponsor an orderly schedule of events, a specification of equipment and organizational requirements, the methodology of testing, a list of materials to be delivered, and a schedule of tests.
- To provide a written record of the actual test inputs to validate the system limits and critical capabilities, the instructions to permit execution of the test by the staff and operator personnel, and the expected outputs.

It is intended that the tests demonstrate the practicality of the AITI Standard (reference d) and that the tests generate a benchmark database. The database will be representative of the many document types and will serve as a benchmark for anyone wishing to employ the AITI Standard.

1-2. PROJECT REFERENCES.

Government Publications -

1. FIPS PUB 79 Magnetic Tape Labels and File Structure for Information Interchange (ANSI, X3.27-1978)

2. FIPS PUB 25 Recorded Magnetic Tape for Information Interchange (1600 CPI, PE) (ANSI X3.39-1973)

3. FIPS PUB 50 Recorded Magnetic Tape for Information Interchange (6250 CPI, Group-coded Recording) (ANSI X3.54-1976)

4. MIL-STD-1840 (USAF) Automated Interchange of Technical Information. 11 September 1986. Draft Revision 15 December 1986.

5. Text Standard Generalized Markup Language, Automated Technical Order System (ATOS), ATOS Project Office (OO-ALC/MMED-3) Hill AFB, Utah 84056. 23 May 1986. Prepared by Datalogics under contract F42650-85-C3410.

6. FED-STD 1065 - Telecommunications: Facsimile Coding Schemes and Coding Control Functions for Group 4 Facsimile Apparatus

Non-government publications -

7. American National Standard for Unrecorded Magnetic Tape for Information Interchange (9-track 200 and 800 CPI, NRZI, and 1600 CPI, PE), ANSI X3.40-1983

8. Initial Graphics Exchange Specification (IGES), Version 3.0, NBSIR 85-3359, U.S. Department of Commerce, National Bureau of Standards, April 1986.

9. Information Processing Systems - Text Preparation and Interchange - Processing and Markup Languages - Part Six: Generic Document Representation Specification (SGML). International Standard ISO 8879. ISO TC97/SC18/WG8, USA Secretariat: ANSI

SECTION I

GENERAL

1-1. PURPOSE OF THE TEST PLAN. The Test Plan for verifying the validity and completeness of the body and the Technical Publication Application appendix of the MIL-STD-1840 (USAF) Automated Interchange of Technical Information (the Standard) has been prepared to fulfill the following objectives:

- To provide guidance for the management and technical effort necessary throughout the test period.
- To establish a comprehensive test plan and to communicate to the sponsor the nature and extent of the tests deemed necessary to provide a basis for evaluation of the Standard.
- To coordinate with the sponsor an orderly schedule of events, a specification of equipment and organizational requirements, the methodology of testing, a list of materials to be delivered, and a schedule of tests.
- To provide a written record of the actual test inputs to validate the system limits and critical capabilities, the instructions to permit execution of the test by the staff and operator personnel, and the expected outputs.

It is intended that the tests demonstrate the practicality of the AITI Standard (reference d) and that the tests generate a benchmark database. The database will be representative of the many document types and will serve as a benchmark for any one wishing to employ the AITI Standard.

1-2. PROJECT REFERENCES.

Government Publications -

a. FIPS PUB 79 Magnetic Tape Labels and File Structure for Information Interchange (ANSI, X3.27-1978)

b. FIPS PUB 25 Recorded Magnetic Tape for Information Interchange (1600 CPI, PE) (ANSI X3.39-1973)

c. FIPS PUB 50 Recorded Magnetic Tape for Information Interchange (6250 CPI, Group-coded Recording) (ANSI X3.54-1976)

d. MIL-STD-1840 (USAF) Automated Interchange of Technical Information. 11 September 1986. Draft Revision 15 December 1986.

e. Text Standard Generalized Markup Language, Automated Technical Order System (ATOS), ATOS Project Office (OO-ALC/MMED-3) Hill AFB, Utah 84056. 23 May 1986. Prepared by Datalogics under contract F42650-85-C3410.

f. FED-STD 1065 - Telecommunications: Facsimile Coding Schemes and Coding Control Functions for Group 4 Facsimile Apparatus

Non-government publications -

g. American National Standard for Unrecorded Magnetic Tape for Information Interchange (9-track, 200 and 800 CPI, NRZI, and 1600 CPI, PE), ANSI X3.40-1983

h. Initial Graphics Exchange Specification (IGES), Version 3.0, NBSIR 85-3359. U.S. Department of Commerce, National Bureau of Standards, April 1986.

i. Information Processing Systems - Text Preparation and Interchange - Processing and Markup Languages - Part Six: Generic Document Representation Specification (SGML). International Standard ISO 8879. ISO TC97/SC18/WG8, USA Secretariat: ANSI

SECTION IV

TEST SPECIFICATION AND EVALUATION

4-1. **TEST SPECIFICATION.** This section presents four major topics: the test requirements, the test methodology, the progression of tests, and the evaluation of test results.

a. **Requirements.** The test requirements are allocated to four categories: magnetic tape media, the Document Declaration File, the Text files, the IGES files, and the CCITT group 4 files.

(1) **Magnetic Tape Media Requirements.** To be accepted, the magnetic tape must meet the following requirements.

1. The magnetic tape must be formatted in accordance with FIPS PUB 79 (reference 1).

2. The tape volume and file labels shall conform with level three or level four of FIPS PUB 79.

3. The data must be written on 9-track tape at a density of 1600 or 6250 bpi in accordance with FIPS PUBS 25, 50, 79 (references 2, 3, 1).

4. The tape volume identifier must consist of six characters. The first four characters shall identify the set and the last two character shall consist of the digits 0-9 and represent the number of the tape volume in the set.

5. The characters in the label must be limited to the ASCII uppercase letters and the digits 0-9.

6. The Document Declaration and Text files must be recorded with ANSI (reference 7) type D variable length records with block lengths of 2048 bytes.

7. The IGES (reference 8) files must be recorded with ANSI type F fixed length 80 byte records with block lengths of 2000 bytes.

8. The CCITT group 4 (reference 6) files must be recorded with the first block containing the the required header records in ANSI type F fixed length records with padding to 2048 bytes. The CCITT data must be written with 128 byte ANSI type F records in blocks of 2048 bytes.

9. The Document Declaration file(s) must precede all other types of files on the tape volume(s).

10. The data files must be grouped in the same order as the Document Declaration files. Files from different documents shall not be intermixed.

11. All records in the Document Declaration File and all header records specified for the text and illustration files are required.

(2) **Document Declaration File Requirements.** To be accepted, a Document Declaration file must meet the following requirements.

1. The filename and all records in the file must be ASCII characters.

2. The filename must contain exactly six characters.

3. The filename must be unique with respect to any other file name to be found in the set of files being transferred.

4. The first three characters of the filename must be 'DOC'.

5. The record type must be ANSI type D.

6. The record lengths must range from one byte to 256 bytes.

7. RECORD 1 - must contain an ASCII string agreed upon by the data source and the destination (SYSCON).

8. RECORD 2 - must contain an agreed upon ASCII string.

9. RECORD 3 - must contain an agreed upon ASCII string, or 'NONE'.

10. RECORD 4 - must contain an agreed upon ASCII string, or 'ORIGINAL'.

11. RECORD 5 - must contain an eight character string representing the date in the format YYYYMMDD, where $1970 \leq YYYY \leq 1987$; $01 \leq MM \leq 12$; $01 \leq DD \leq 31$.

12. RECORD 6 - must contain an agreed upon ASCII string.

13. RECORD 7 - must contain an agreed upon ASCII string.

14. RECORD 8 - must contain an agreed upon ASCII string, or 'NONE'.

15. RECORD 9 - must contain an eight character string representing the date in the format YYYYMMDD, where $1986 \leq YYYY \leq 1987$; $01 \leq MM \leq 12$; $01 \leq DD \leq 31$.

16. RECORD 10 - must contain an agreed upon ASCII string, or 'NONE'.

17. RECORD 11 - must contain one, two, three or four groups of ASCII digits. The groups must be separated with a comma. A space code following the comma is acceptable. The first group must

SECTION IV

TEST SPECIFICATION AND EVALUATION

4-1. TEST SPECIFICATION. This section presents four major topics: the test requirements, the test methodology, the progression of tests, and the evaluation of test results.

a. Requirements. The test requirements are allocated to four categories: magnetic tape media, the Document Declaration File, the Text files, the IGES files, and the CCITT group 4 files.

(1) Magnetic Tape Media Requirements. To be accepted, the magnetic tape must meet the following requirements.

(a) The magnetic tape must be formatted in accordance with FIPS PUB 79 (reference 1).

(b) The tape volume and file labels shall conform with level three or level four of FIPS PUB 79.

(c) The data must be written on 9-track tape at a density of 1600 or 6250 bpi in accordance with FIPS PUBS 25, 50, 79 (references 2, 3, 1).

(d) The tape volume identifier must consist of six characters. The first four characters shall identify the set and the last two character shall consist of the digits 0-9 and represent the number of the tape volume in the set.

(e) The characters in the label must be limited to the ASCII uppercase letters and the digits 0-9.

(f) The Document Declaration and Text files must be recorded with ANSI (reference 7) type D variable length records with block lengths of 2048 bytes.

(g) The IGES (reference 8) files must be recorded with ANSI type F fixed length 80 byte records with block lengths of 2000 bytes.

(h) The CCITT group 4 (reference 6) files must be recorded with the first block containing the the required header records in ANSI type F fixed length records with padding to 2048 bytes. The CCITT data must be written with 128 byte ANSI type F records in blocks of 2048 bytes.

(i) The Document Declaration file(s) must precede all other types of files on the tape volumet(s).

(j) The data files must be grouped in the same order as the Document Declaration files. Files from different documents shall not be internixed.

(k) All records in the Document Declaration File and all header records specified for the text and illustration files are required.

(2) Document Declaration File Requirements. To be accepted, a Document Declaration file must meet the following requirements.

(a) The filename and all records in the file must be ASCII characters.

(b) The filename must contain exactly six characters.

(c) The filename must be unique with respect to any other file name to be found in the set of files being transferred.

(d) The first three characters of the filename must be 'DOC'.

(e) The record type must be ANSI type D.

(f) The record lengths must range from one byte to 256 bytes.

(g) RECORD 1 - must contain an ASCII string agreed upon by the data source and the destination (SYSCON).

(h) RECORD 2 - must contain an agreed upon ASCII string.

(i) RECORD 3 - must contain an agreed upon ASCII string, or 'NONE'.

(j) RECORD 4 - must contain an agreed upon ASCII string, or 'ORIGINAL'.

(k) RECORD 5 - must contain an eight character string representing the date in the format YYYYMMDD, where 1970 < YYYY < 1987; 01 < MM < 12; 01 < DD < 31.

(l) RECORD 6 - must contain an agreed upon ASCII string.

(m) RECORD 7 - must contain an agreed upon ASCII string.

(n) RECORD 8 - must contain an agreed upon ASCII string, or 'NONE'.

(o) RECORD 9 - must contain an eight character string representing the date in the format YYYYMMDD, where 1986 < YYYY < 1987; 01 < MM < 12; 01 < DD < 31.

(p) RECORD 10 - must contain an agreed upon ASCII string, or 'NONE'.

Table 5-1. Test Procedure for TAPEVAL Magnetic Tape Validation Program.

Operator Action	Test Step/Expected Result	Pass/Fail Criteria
1. Mount/load tape to be tested on tape drive.	Tape mounted and at load point.	load/ready light displayed on tape unit.
2. Run TAPEVAL.COM command file.	Prompt displayed to enter tape volume label.	
3. Enter tape volume label at keyboard.	Prompt displayed to enter root directory to contain output files.	
4. Enter root directory at keyboard.	Prompt displayed for directory to contain tape label block scan results.	
5. Enter directory to receive SCANTAPE results.	Tapes moves across all documents on tape and then rewinds.	Successful tape Mount Message appears here.
6. Enter directory to store file name validations in FNVAL.	Display asks for directory to store FNVAL results in.	
7. Enter Y if FNVAL gave a good return.	Display asks if ti is OK to continue?	
8. Enter directory to store header results form DOCDECVAL execution.	Files are copied to system in preparation for header scan. Display asks for directory to contain DOCDECVAL header scan results.	TAPEVAL has run to completion.

Table 5-1. Test Procedure for TAPEVAL Magnetic Tape Validation Program.

Operator Action	Test Step/Expected Result	Pass/Fail Criteria
9. Print the catalog and process log files.		
i. Examine log files for any unrepaired discrepancies. Repair as required to continue test.		filenames and the ATOS component numbers, make a correspondence list for copying files. (Written. MOVEFILES.COM, COPYFILES.COM, DOEXTRACT.COM, MOVEFILES.DAT)
j. Using ATOS Manager menu and LEP gencode, define an ATOS job for this document. (ATOS staff will automate this process in '87.)		<ul style="list-style-type: none"> • @MOVEFILES 'jobname'
k. logout of AITI account.		
l. Login to ATOS as DLHOWE , type in 'MENU' and select the 'jobname', type in 'P' then type in 'E'. Get the menu listing from the line printer.		<ul style="list-style-type: none"> • @PSAVEFILES 'jobname'
m. Change directory to the 'jobname' directory. <ul style="list-style-type: none"> • CD ['.jobname'] • COPYTOOLS 'jobname' 		<ul style="list-style-type: none"> • @FINALPASS 'jobname'
n. Using EDIT, make appropriate adjustments to the PSAVEFILES*.DAT files. PSAVEFILES.DAT must have as many blank lines followed by 'E' as there are components listed on the menu print out. PSAVEFILES3.DAT must have the ordinal number of the TOC component and then an 'E'. PSAVEFILES2.DAT must have the ordinal number of the LEP component and then a 'E'.		<ul style="list-style-type: none"> • @FINALPASS 'jobname'
o. Copy text file components from the Test data directory to appropriate DLHOWE directories. If there is not a regular correspondence between the MARKUPnnnn.TXT		<ul style="list-style-type: none"> • @FINALPASS 'jobname'
		<ul style="list-style-type: none"> • @FINALPASS 'jobname'
		<ul style="list-style-type: none"> • @FINALPASS 'jobname'
		<ul style="list-style-type: none"> • @FINALPASS 'jobname'
		<ul style="list-style-type: none"> • @FINALPASS 'jobname'
		<ul style="list-style-type: none"> • @FINALPASS 'jobname'
		<ul style="list-style-type: none"> • @FINALPASS 'jobname'
		<ul style="list-style-type: none"> • @FINALPASS 'jobname'
		<ul style="list-style-type: none"> • @FINALPASS 'jobname'
		<ul style="list-style-type: none"> • @FINALPASS 'jobname'
		<ul style="list-style-type: none"> • @FINALPASS 'jobname'
		<ul style="list-style-type: none"> • @FINALPASS 'jobname'
		<ul style="list-style-type: none"> • @FINALPASS 'jobname'
		<ul style="list-style-type: none"> • @FINALPASS 'jobname'
		<ul style="list-style-type: none"> • @FINALPASS 'jobname'
		<ul style="list-style-type: none"> • @FINALPASS 'jobname'
		<ul style="list-style-type: none"> • @FINALPASS 'jobname'
		<ul style="list-style-type: none"> • @FINALPASS 'jobname'

Table 5-1. Test Procedure for TAPEVAL Magnetic Tape Validation Program

Operator Action	Test Step/Expected Result	Pass/Fail Criteria
1. Mount/load tape to be tested on tape drive.	Tape mounted and at load point.	load/ready light displayed on tape unit.
2. Run TAPEVAL.COM command file.	Prompt displayed to enter tape volume label.	
3. Enter tape volume label at keyboard.	Prompt displayed to enter root directory to contain output files.	
4. Enter root directory at keyboard.	Prompt displayed for directory to contain tape label block scan results.	
5. Enter directory to receive SCANTAPE results.	Tapes moves across all documents on tape and then rewinds.	Successful tape Mount Message appears here.
6. Enter directory to store file name validations in FNVAL.	Display asks for directory to store FNVAL results in.	
7. Enter Y if FNVAL gave a good return.	Display asks if ti is OK to continue?	
8. Enter directory to store header results form DOCDECVAL execution.	Files are copied to system in preparation for header scan. Display asks for directory to contain DOCDECVAL header scan results.	TAPEVAL has run to completion.
9. Print the catalog and process log files.		

THIS PAGE LEFT BLANK INTENTIONALLY

NAVAIR 03-45BV-6

TECHNICAL MANUAL

OVERHAUL INSTRUCTIONS WITH ILLUSTRATED PARTS LIST

STANDARD CONTROL PANEL

**A02VS110-1
(CG1127AA01)**

**HONEYWELL INC.
N00019-82-G-0067**

This publication is required for official use or for administrative or operational purposes only. Distribution is limited to U.S. Government agencies. Other requests for this document must be referred to Commanding Officer, Naval Air Technical Services Facility, 700 Robbins Avenue, Philadelphia, PA 19111.

Published by direction of the Commander, Naval Air Systems Command.

NAVAIR 03-45BV-6

TECHNICAL MANUAL

**OVERHAUL INSTRUCTIONS
WITH ILLUSTRATED PARTS LIST**

STANDARD CONTROL PANEL

A02VS110-1

(CG1127AA01)

HONEYWELL INC.
N00019-82-G-0067

This publication is required for official use or for administrative or operational purposes only. Distribution is limited to U.S. Government agencies. Other requests for this document must be referred to Commanding Officer, Naval Air Technical Services Facility, 700 Robbins Avenue, Philadelphia, PA 19111.

Published by direction of the Commander, Naval Air Systems Command.

NAVAIR 03-45BV-6

SECTION I
INTRODUCTION

1-1 EQUIPMENT DESCRIPTION.

1-1.1 Physical Characteristics. The control panel (figure 1-1) is a line-replaceable unit. Leading particulars are listed in table 1-1. All internal electrical circuits are hardwired with soldered or screw terminal connections; no printed circuit card assemblies are used. Two cable connectors on the back of the unit provide connection points for operation and test.

1-1.2 Functional Characteristics. The control panel is a component of the YG1773A01 Automatic Flight Control System (AFCS) used on the Boeing-Vertol CH-46 Helicopter. Four switches located on the control panel provide manual control of the AFCS unit. The switches are identified as follows:

1. AFCS (1/2/BOTH/OFF).
2. CYCLIC TRIM (TAXI/AUTO/FWD).
3. ALT HOLD (BARO/OFF/RDR).
4. HDG HOLD (ON/OFF).

1-2 GROUND SUPPORT EQUIPMENT.

1-2.1 Authorized GSE. Authorized GSE for depot-level maintenance of the control panel consists of the A02GS058-1 Bench-AFCS Test Set (AFCS bench test set) and assorted hand tools. Section II contains a list of the required GSE. GSE-related publications are listed in the foreword.

1-2.2 AFCS Bench Test Set. The AFCS bench test set simulates operating conditions for the control panel. The control panel is connected to the AFCS bench test set with cabling supplied with the test set. The AFCS bench test set is required for checkout, test, and troubleshooting procedures.

1-2.3 Hand Tools. Hand tools are required for disassembly, repair, and assembly procedures.

Table 1-1. Leading Particulars

Characteristic	Requirement
Width	5.75 in.
Depth	5.38 in.
Height	4.88 in.
Weight	2 lb 10 oz
Input power	Provided by aircraft or test set: +28 ± 4.0 Vdc; +12 ± 0.5 Vdc; 5 ± 0.5V rms, 400 ± 10 Hz single phase, 5 amp minimum

SECTION I

INTRODUCTION

1-1 EQUIPMENT DESCRIPTION.

1-1.1 Physical Characteristics. The control panel (figure 1-1) is a line-replaceable unit. Leading particulars are listed in table 1-1. All internal electrical circuits are hardwired with soldered or screw terminal connections; no printed circuit card assemblies are used. Two cable connectors on the back of the unit provide connection points for operation and test.

1-1.2 Functional Characteristics. The control panel is a component of the YG1773A01 Automatic Flight Control System (AFCS) used on the Boeing-Vertol CH-46 Helicopter. Four switches located on the control panel provide manual control of the AFCS unit. The switches are identified as follows:

1. AFCS (1/2/BOTH/OFF).
2. CYCLIC TRIM (TAXI/AUTO/FWD).
3. ALT HOLD (BARO/OFF/RDR).

4. HDG HOLD (ON/OFF).

1-2 GROUND SUPPORT EQUIPMENT.

1-2.1 Authorized GSE. Authorized GSE for depot-level maintenance of the control panel consists of the A02GS058-1 Bench-AFCS Test Set (AFCS bench test set) and assorted hand tools. Section II contains a list of the required GSE. GSE-related publications are listed in the foreword.

1-2.2 AFCS Bench Test Set. The AFCS bench test set simulates operating conditions for the control panel. The control panel is connected to the AFCS bench test set with cabling supplied with the test set. The AFCS bench test set is required for check-out, test, and troubleshooting procedures.

1-2.3 Hand Tools. Hand tools are required for disassembly, repair, and assembly procedures.

Table 1-1. Leading Particulars

Width	5.75 in.
Depth	5.38 in.
Height	4.88 in.
Weight	2 lb 10 oz
Input power	Provided by aircraft or test set: +28 ± 4.0 Vdc; +12 ± 0.5 Vdc; 5 ± 0.5V rms, 400 ± 10 Hz single phase, 5 amp minimum

..AVAIR 03-45BV-6

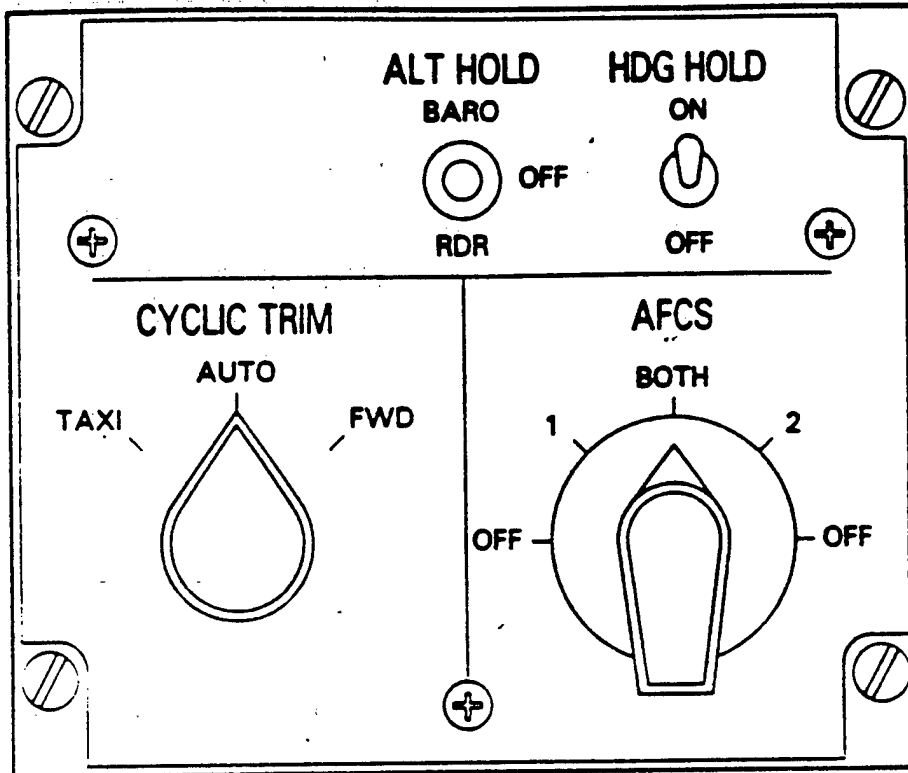

95-8253/1-1
CG1127AA (M)

Figure 1-1. CG1127 Standard Control Panel

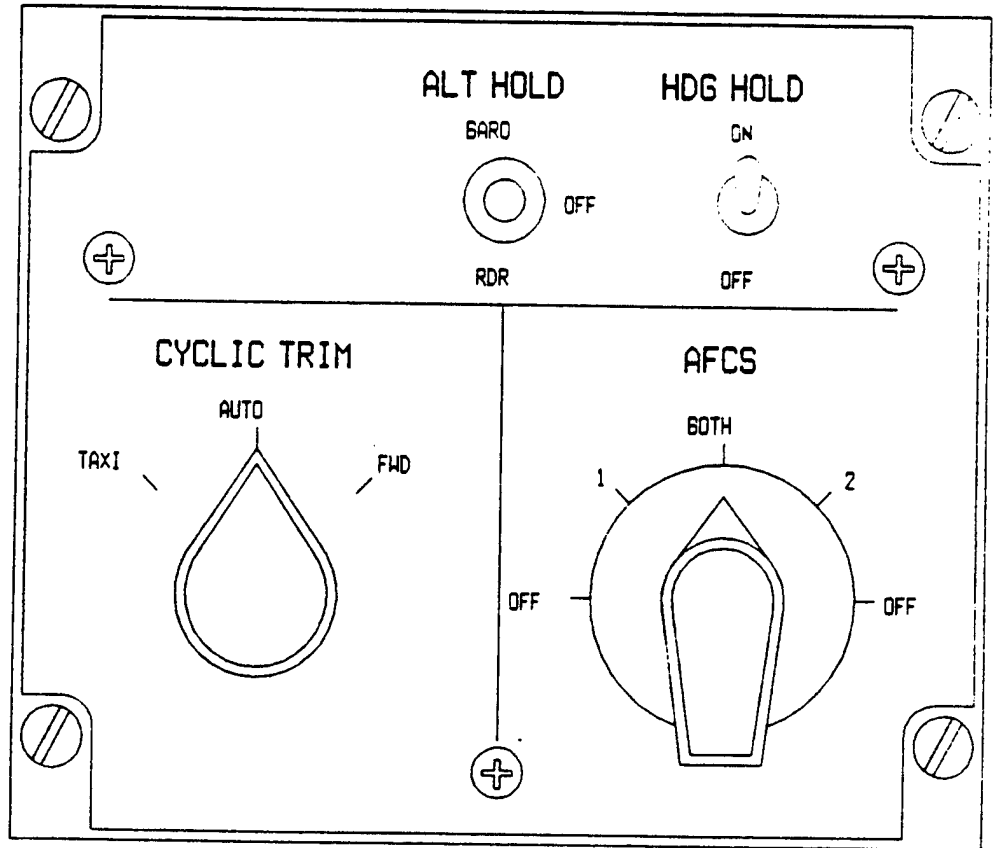

95-8253/1-1
CG1:12700



CYCLIC TRIM

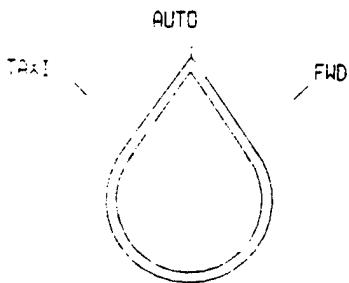

NAVAIR 03-45BV-6

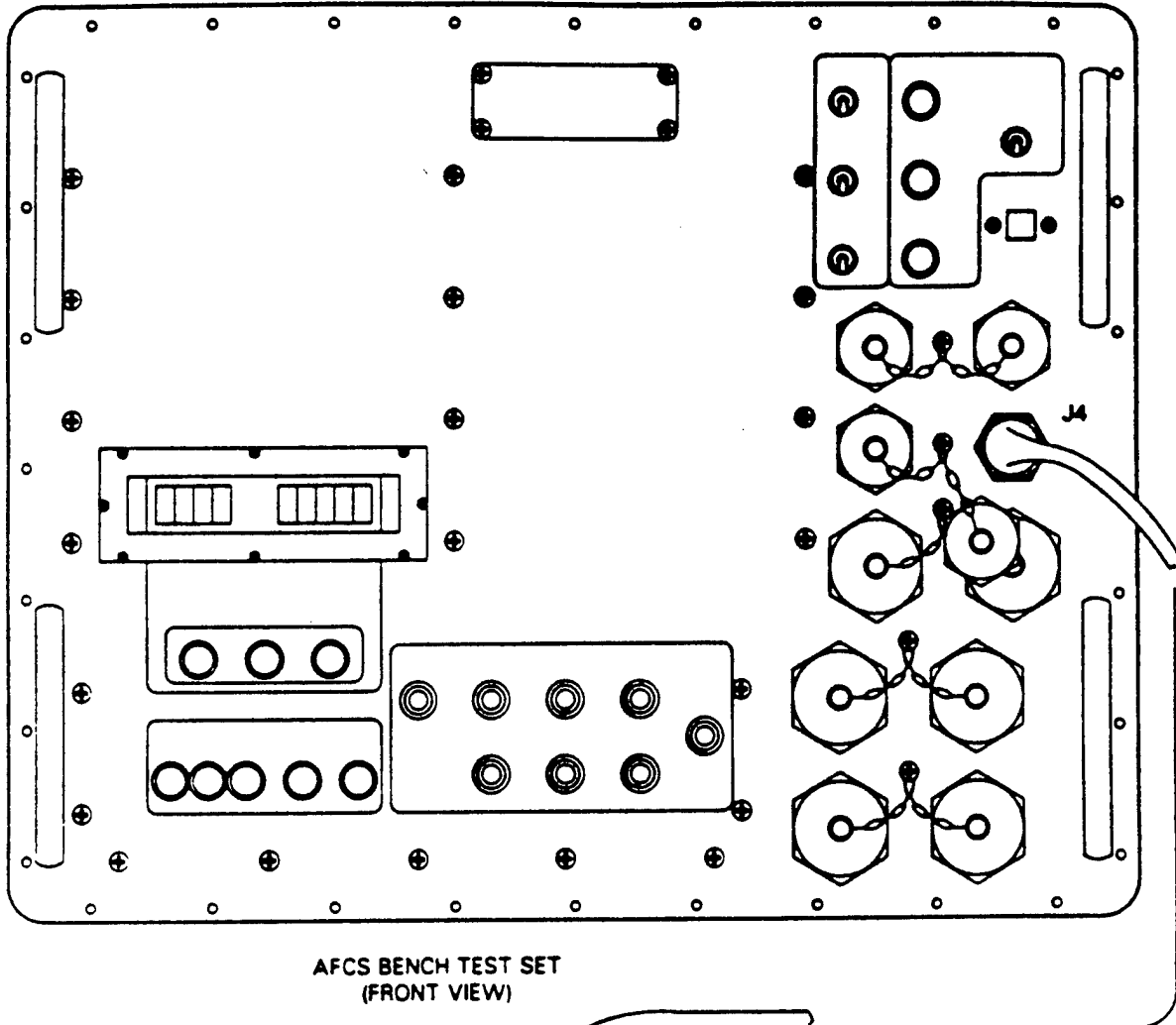

AFCS BENCH TEST SET
(FRONT VIEW)

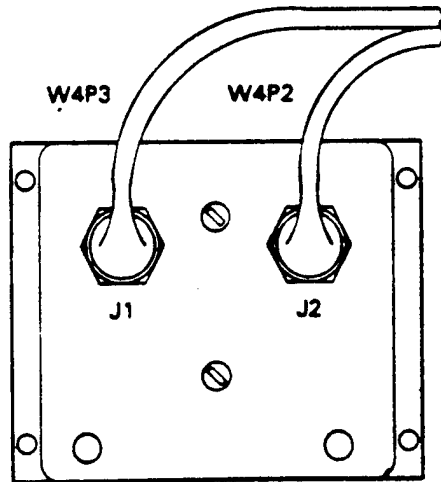

CABLE W4 FROM TEST SET
J4 TO CONTROL PANEL J1 AND J2

CONTROL PANEL
(REAR VIEW)

95-8253/4-1A
10082500 (C)

Figure 4-1. Test Setup

AITI Test Report 87-003
 Exhibit 16 - As Transmitted &
 Processed

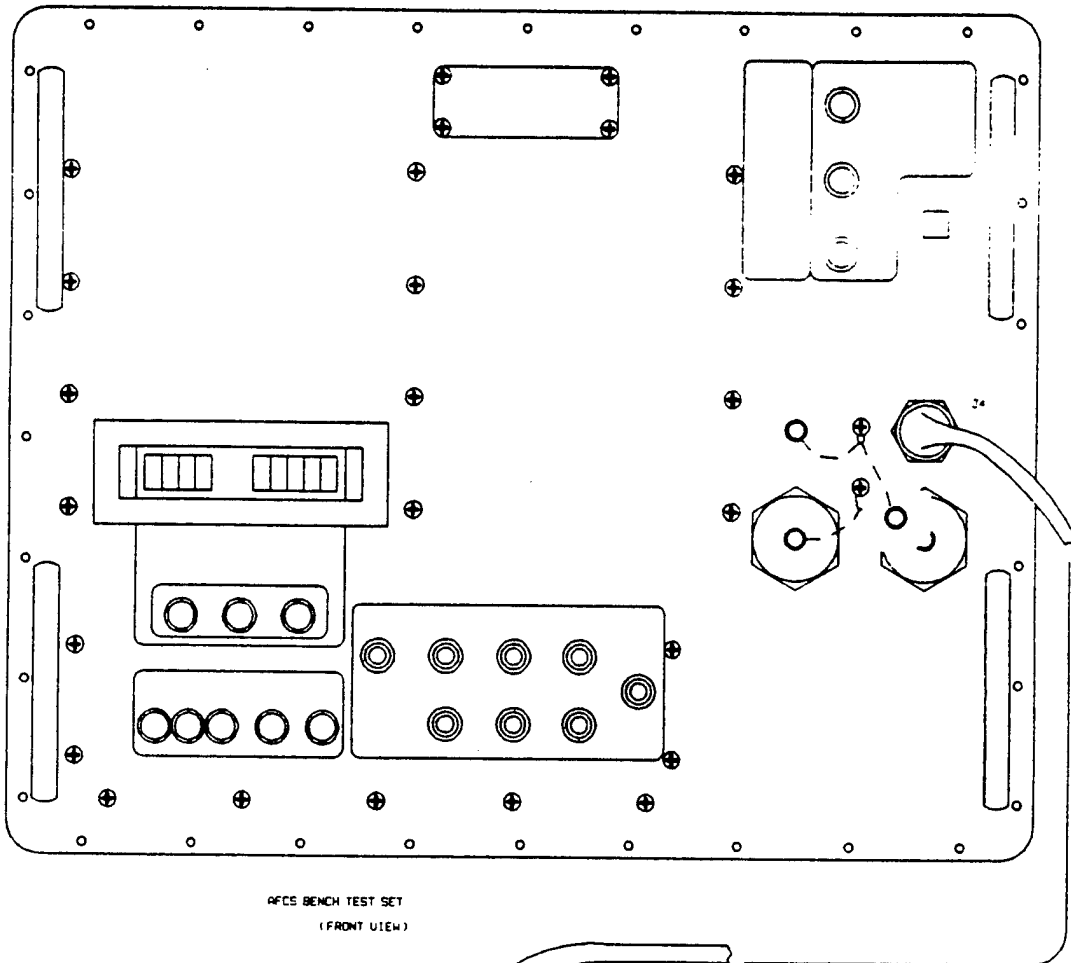

AFCS BENCH TEST SET
 (FRONT VIEW)

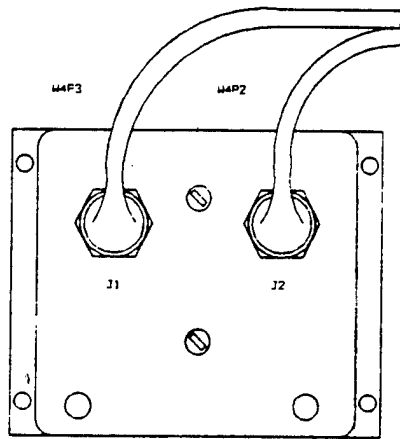

CONTROL PANEL
 (REAR VIEW)

CABLE 24 FROM TEST SET
 24 TO CONTROL PANEL J1 AND J2

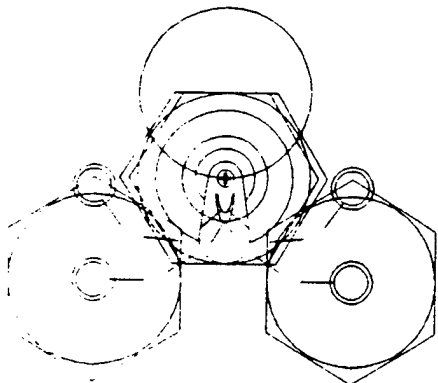

95-3253/4-16
 10032500

CONNECTOR J1
(FRONT VIEW)

AITI Test Report 87-003
Exhibit 18 - As Transmitted &
Processed

CONNECTOR J2
(FRONT VIEW)

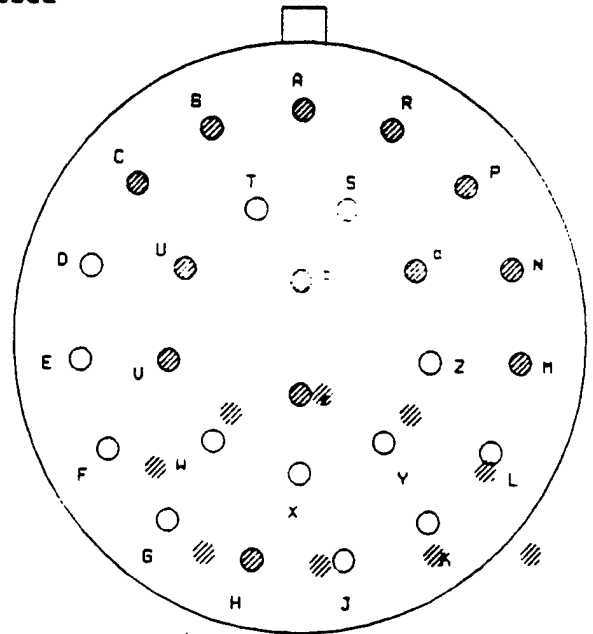
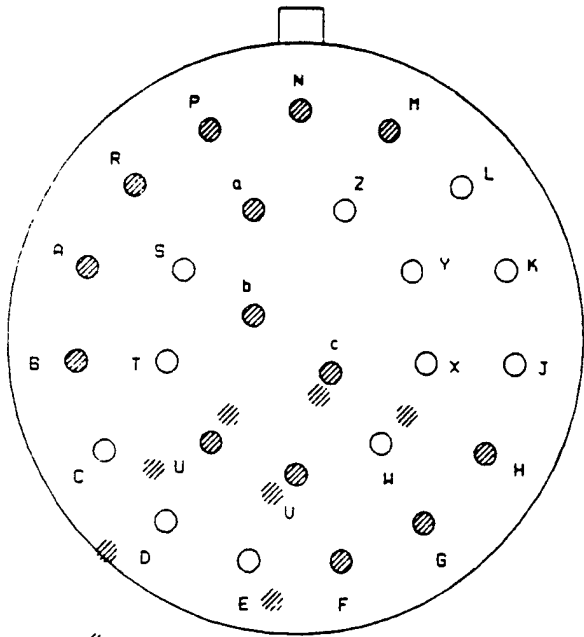

⊙ INDICATES CONTACT CONNECTION POINTS

CONNECTOR J1 PINS		CONNECTOR J2 PINS	
FROM	TO	FROM	TO
N	S4-61	A	S3-31
M	S3-25	B	J3-1
P	S4-64	C	J3-2
R	S4-62	R	S4-52
a	S4-43	P	S4-54
A	S3-11	N	S4-51
B	S2-8	a	S4-23
b	S4-41	b	S4-21
c	S4-44	U	S4-13
U	S4-33	U	S4-11
U	S4-31	c	S4-24
H	S1-3	M	S3-36
G	S2-3	H	S1-6
F	S2-6		