



CALS TEST NETWORK

**AFCTN Test Report
94-012**

**AFTB-ID
93-017**



Technical Publication Transfer

Using



Northrop Corporation Data

MIL-D-28000A (IGES)

MIL-M-28001A (SGML)

MIL-R-28002A (Raster)

MIL-D-28003A (CGM)

19960822 090

Quick Short Test Report

7 March 1993



Prepared for
Electronic Systems Center

DTIC QUALITY IMPROVED IS

DISTRIBUTION STATEMENT A
Approved for public release;
Distribution Unlimited

AFCTN Test Report
94-012

AFCTB-ID
93-017

**Technical Publication Transfer
Using:
Northrop Corporation's Data**

**MIL-D-28000A (IGES)
MIL-M-28001A (SGML)
MIL-R-28002A (Raster)
MIL-D-28003 (CGM)**

Quick Short Test Report

07 March 1993

Prepared By
Air Force CALS Test Bed
Wright-Patterson AFB, OH 45433

AFCTB Contact
Gary Lammers
(513) 427-2295

AFCTN Contact
Mel Lammers
(513) 427-2295

DTIC QUALITY INSPECTED 3

DISCLAIMER

This document was prepared as an account of work sponsored by the Air Force. Neither the United States Government, the Air Force, nor any of their employees makes any warranty, express or implied, or assumes any legal liability or responsibility for the accuracy, completeness, or usefulness of any information, apparatus, product, or process disclosed, nor represents that its use would not infringe on privately owned rights. Reference herein to any specific commercial products, process, or service by trade name, trademark, manufacturer, or otherwise, does not necessarily constitute or imply its endorsement, recommendation, or favoring by the United States Government or the Air Force. The views and opinions of authors expressed herein do not necessarily state or reflect those of the United States Government or the Air Force, and shall not be used for advertising or product endorsement purposes.

Available to the public from the
National Technical Information Service
U.S. Department of Commerce
5285 Port Royal Road
Springfield, VA 22161

This report and those involved in its preparation do not endorse any product, process, or company stated herein. Use of these means by anyone does not imply certification by the Air Force CALS Test Network (AFCTN).

Contents

| | | |
|---------|--|----|
| 1. | Introduction..... | 1 |
| 1.1. | Background..... | 1 |
| 1.2. | Purpose..... | 2 |
| 2. | Test Parameters..... | 3 |
| 3. | 1840A Analysis..... | 6 |
| 3.1. | External Packaging..... | 6 |
| 3.2. | Transmission Envelope..... | 6 |
| 3.2.1. | Tape Formats..... | 6 |
| 3.2.2. | Declaration and Header Fields..... | 6 |
| 4. | IGES Analysis..... | 7 |
| 5. | SGML Analysis..... | 8 |
| 6. | Raster Analysis..... | 9 |
| 7. | CGM Analysis..... | 10 |
| 8. | Conclusions and Recommendations..... | 12 |
| 9. | Appendix A - Tapetool Report Logs..... | 13 |
| 9.1. | Tape Catalog..... | 13 |
| 9.2. | Tape Evaluation Log..... | 14 |
| 9.3. | Tape File Set Validation Log..... | 19 |
| 10. | Appendix B - Detailed IGES Analysis..... | 23 |
| 10.1. | File Q004..... | 23 |
| 10.1.1. | Parser/Verifier Log..... | 23 |
| 10.1.2. | Output IGESView..... | 28 |

| | | |
|---------|--|----|
| 10.1.3. | Output IGESWorks..... | 29 |
| 10.1.4. | Output Preview..... | 30 |
| 10.2. | File Q005..... | 31 |
| 10.2.1. | Parser/Verifier Log..... | 31 |
| 10.2.2. | Output IGESView..... | 36 |
| 10.2.3. | Output IGESWorks..... | 37 |
| 10.2.4. | Output Preview..... | 38 |
| 10.3. | File Q006..... | 39 |
| 10.3.1. | Parser/Verifier Log..... | 39 |
| 10.3.2. | Output IGESView..... | 44 |
| 10.3.3. | Output IGESWorks..... | 45 |
| 10.3.4. | Output Preview..... | 46 |
| 10.4. | File Q007..... | 47 |
| 10.4.1. | Parser/Verifier Log..... | 47 |
| 10.4.2. | Output IGESView..... | 52 |
| 10.4.3. | Output IGESWorks..... | 53 |
| 10.4.4. | Output Preview..... | 54 |
| 11. | Appendix C - Detailed SGML Analysis..... | 55 |
| 11.1. | Parser Log..... | 55 |
| 11.1.1. | DTD Log..... | 55 |
| 11.1.2. | Text Log..... | 55 |
| 11.2. | Exoterica Parser..... | 56 |
| 11.2.1. | First Pass - DTD..... | 56 |
| 11.2.2. | Second Pass - DTD..... | 56 |

| | | |
|---------|--|----|
| 11.3. | SGMLs Parser Log..... | 56 |
| 12. | Appendix D - Detailed Raster Analysis..... | 57 |
| 12.1. | File R009..... | 57 |
| 12.1.1. | Output g42tiff/IslandPaint..... | 57 |
| 12.1.2. | Output HiJaak for Windows..... | 58 |
| 13. | Appendix E - Detailed CGM Analysis..... | 59 |
| 13.1. | File C008..... | 59 |
| 13.1.1. | Parser Log MetaCheck..... | 59 |
| 13.1.2. | validcgm Log..... | 60 |
| 13.1.3. | Output Harvard Graphics..... | 62 |
| 13.1.4. | Output cgm2draw/IslandDraw..... | 63 |

1. Introduction

1.1 Background

The Department of Defense (DoD) Air Force Continuous Acquisition and Life-Cycle Support (CALs) Test Network (AFCTN) is conducting tests of the military standard for the Automated Interchange of Technical Information, MIL-STD-1840A, and its companion suite of military specifications. The AFCTN is a DoD sponsored confederation of voluntary participants from industry and government managed by the Electronic Systems Center (ESC).

The primary objective of the AFCTN is to evaluate the effectiveness of the CALs standards for technical data interchange and to demonstrate the technical capabilities and operational suitability of those standards. Two general categories of tests are performed to evaluate the standards; formal and informal.

Formal tests are large and comprehensive, which follow a written test plan, require specific authorization from the DoD, and may take months to prepare, execute, and report.

Informal tests are quick and short, used by the AFCTN technical staff, to broaden the testing base. They include representative samples of the many systems and applications used by AFCTN participants. They also allow the AFCTN staff to gain feedback from many industry and government interpretations of the standards, to increase the base of participation in the CALs initiative, and respond to the many requests for help that come from participants. Participants take part voluntarily, benefit by receiving an evaluation of their latest implementation (interpretation) of the standards, interact with the AFCTN technical staff, gain experience using the standards, and develop increased confidence in them. The results of informal tests are reported in Quick Short Test Reports (QSTRs) that briefly summarize the standard(s) tested, the hardware and software used, the nature of the test, and the results.

1.2 Purpose

The purpose of the informal test, reported in this QSTR, was to analyze Northrop Corporation's interpretation and use of the CALS standards in transferring technical publication data. Northrop used its CALS Technical Data Interchange System to produce data, in accordance with the standards, and delivered it to the AFCTN technical staff on a 9-track magnetic tape.

2. Test Parameters

Test Plan: AFCTB 93-017

Date of Evaluation: 7 March 1993

Evaluators: George Elwood
Air Force CALS Test Bed
HQ AFMC/ENCT
Suite 200
4027 Col Glenn Hwy
Dayton OH 45431

Data Originator: John P. Kent
Northrop Corporation
B-2 Division
L591/GK
8900 East Washington Blvd
Pico Rivera CA 90660
(310) 948-0624

Data Description: Technical Manual Test
1 Document Declaration file
4 Initial Graphics Exchange Specification (IGES) files
1 Text/Standard Generalized Markup Language (SGML) file
1 Raster file
1 Computer Graphics Metafile (CGM) file
1 Format Output Specification Instance (FOSI)

Data Source System:

IGES

HARDWARE

Unknown

SOFTWARE

Unknown

Text/SGML
 HARDWARE Unknown
 SOFTWARE Unknown

Raster
 HARDWARE Unknown
 SOFTWARE Unknown

CGM
 HARDWARE Unknown
 SOFTWARE Unknown

Evaluation Tools Used:

MIL-STD-1840A (TAPE)
 SUN 3/280
 AFCTN Tapetool v1.2.8 UNIX
 XSoft CAPS/CALS v40.4
 Texas Instruments (TI) Tapetool v1.0.1

MIL-D-28000 (IGES)
 Sun SparcStation 2
 ArborText *iges2draw*
 IGES Data Analysis (IDA) *Parser/Verifier v92*
 IDA *IGESView v3.05*
 International TechneGroup Incorporated
 (ITI) *IGES/Works v1.3*
 Rosetta Technologies *Preview v3.2*

MIL-M-28001 (SGML)
 Cheetah Gold 486
 Exoterica *XGMLNormalizer v1.2e3.2*
 Public Domain *sgmls*

MIL-R-28002 (Raster)
 SUN SparcStation 2
 ArborText *g42tiff*
 AFCTN *validg4*
 AFCTN *calstb.475*
 IDA *IGESView v3.0*
 Island Graphics *IslandPaint v3.0*

Cheetah

Inset Systems *HiJaak v2.1*
Inset Systems *HiJaak Window v1.0*
Software Publishing Corporation
(SPC) *Harvard Graphics v3.0*
Corel Ventura Publisher

MIL-D-28003 (CGM)

SUN SparcStation 2
ArborText *cgm2draw*
Island Graphics *IslandDraw v3.0*
Cheetah Gold 486
Advance Technology Center
(ATC) *MetaView R 1.12*
ATC *MetaCheck R 2.05*
SPC *Harvard Graphics v3.05*
Inset Systems *HiJaak v2.1*
Inset Systems *HiJaak v1.0 Windows*
Micrografx *Designer v3.1*
Micrografx *Charisma v2.1*
Corel Ventura Publisher

Standards

Tested:

MIL-STD-1840A
MIL-D-28000A
MIL-M-28001A
MIL-R-28002A
MIL-D-28003

3. 1840A Analysis

3.1 External Packaging

The tape arrived at the Air Force CALS Test Bed (AFCTB) enclosed in a box in accordance with ASTM D 3951. The exterior of the box was marked with the magnetic tape warning label, as required by MIL-STD-1840A, para. 5.3.1.3.

The tape was not enclosed in a barrier bag as required by MIL-STD-1840A, para. 5.3.1.2. Inspection of the tape reel showed the label indicating the recording density, as required by MIL-STD-1840A, para. 5.3.1. Enclosed in the box was a packing list showing all files recorded on the tape.

3.2 Transmission Envelope

The 9-track tape received by the AFCTB contained MIL-STD-1840A files. The files were named per the standard conventions.

3.2.1 Tape Formats

The tape was run through the AFCTB *Tapetool* v1.2.8 utility. No errors were encountered while evaluating the contents of the tape labels.

The tape was also evaluated using TI's version of *Tapetool*. No errors were reported from this program.

3.2.2 Declaration and Header Fields

No errors were found in the Document Declaration file or data file headers.

4. IGES Analysis

The tape contained four IGES files. These files were evaluated using IDA's *Parser* and *Verifier* set for CALS Class I. No CALS errors were reported. All four files did contain basic IGES errors of two types.

*** Entity type: 104

WARNING 2265: Start point off conic by 1.336260E-03 at D 969.
WARNING 2039: End point off conic by 1.336260E-03 at D 969.

*** Entity type: 112

WARNING 2238: Polynomial segment (4) at D 1343 is degenerate.
WARNING 2238: Polynomial segment (1) at D 1487 is degenerate.

The AFCTB has several tools for viewing IGES files. These tools are not used to generate a pass/fail but to report how commercially available software can handle the files. Many of these products are used in the development of technical publications and are good indicators of usability. The use of these products is not an endorsement nor an indication of CALS capability. All operations were performed using the default settings.

All four files were converted using ArborText's *iges2draw* utility with no reported errors. When the resulting files were read into Island Graphics' *IslandDraw* nothing displayed. This error was reported to ArborText.

All four files were converted using Rosetta Technologies' *Prepare* and then viewed and printed using *Preview* with no problems. All files appeared to be complete.

All four files were read directly into IDA's *IGESView*, displayed, and printed without a reported error. The resulting files appear to be complete.

All four files were read into ITI's *IGESWorks* with no reported problems. The files displayed and printed what appear to be complete files.

The IGES files meet the CALS MIL-D-28000A specification.

5. SGML Analysis

The tape contained one text, one DTD, and one FOSI files. The AFCTB did not evaluate the FOSI.

The DTD was evaluated using the Exoterica *XGMLNormalizer* parser. The first pass through the DTD generated two errors. One was for an external entity which the AFCTB did not have. It should be noted that this is not an ISO external entity reference file. If this file is to be referenced, it should be included on the tape. When this entity was commented out, one error was still generated. This error referenced a content model which was judged ambiguous.

```
<!ENTITY % PUBspc PUBLIC "ISO 8879-1986//ENTITIES Tech Pubs  
Special Characters//EN">
```

```
C:\XGML\XGMLNORM.EXE --  
Error on line 467 in file entities/9317.dtd:  
A content model is ambiguous.  
For element 'TOC'. The input is 'CONTENTSENTRY'.  
<!-- The document prolog is in error. -->
```

The DTD was evaluated using another parser available within the AFCTB. The DTD was corrected by commenting out the external entity which did not exist in the AFCTB. It reported no errors. The DTD was then used to parse the included text file, and again, no errors were reported.

The DTD was parsed using the Public Domain *sgmls* parser after the unknown external entity and graphics entities were commented out. The parser reported the same ambiguous content model as the Exoterica parser. No errors were reported in the text file.

The SGML part of the tape does not meet the CALS MIL-M-28001A specification. The use of unknown external references should be made without including the required files. The DTD had a reported ambiguous content model.

6. Raster Analysis

The tape contained one Raster file. This file was evaluated using the AFCTN *validg4* utility. This program reported the file to be in error.

```
density      = 300  
path length  = 312  
scan lines   = 500  
bit format   = MSB
```

error reading input file

The an attempt to read the file into the AFCTN *calstb.475* generated a core dump.

The AFCTB has several tools for viewing Raster files. These tools are not used to generate a pass/fail but to report how commercially available software can handle the files. Many of these products are used in the development of technical publications and are good indicators of usability. The use of these products is not an endorsement nor an indication of CALS capability. All operations were performed using the default settings.

The file was read into Inset Systems' *HiJaak for Windows*. The image consisted of random lines. Per Beverly Bernard of Inset Systems, "the problems associated with *HiJaak for Windows v1.0* has been corected in *HiJaak PRO v2.0*."

The file was converted using ArborText's *g42tiff* utility with no report errors. When the resulting file was read into Island Graphics' *IslandPaint* only random lines were displayed.

The Raster file does not meet the CALS MIL-R-28002A specification.

7. CGM Analysis

The file was evaluated using ATC's *MetaCheck* with CALS options. This utility reported the file as meeting MIL-D-28003 specification.

The file was also evaluated using the AFCTN beta *validcgm* utility. This program reported one error. The log is in the Appendix to this report.

The AFCTB has several tools for viewing CGM files. These tools are not used to generate a pass/fail but to report how commercially available software can handle the files. Many of these products are used in the development of technical publications and are good indicators of usability. The use of these products is not an endorsement nor an indication of CALS capability. All operations were performed using the default settings.

The file was converted using ArborText's *cgm2draw* utility with no reported errors. The resulting file was read into Island Graphics' *IslandDraw*, displayed, and printed. The image appeared to be complete and usable.

The file was imported directly into Island Graphics' *IslandDraw*. The image appeared to be drawn along the top of the screen. It was not completely visible. When printed, nothing was generated.

The file was imported into SPC's *Harvard Graphics v3.05* with reported line style errors. The image displayed consisted of random lines.

An attempt was made to read the file into Inset Systems' *HiJaak for Windows* and the *Micrografx Designer*. Both programs reported errors and would not process the file. When the file read using Corel's *Ventura Publisher* and Inset Systems' *HiJaak for DOS*, the system hung and had to be rebooted.

According to Michael Harrison of Micrografx, "Micrografx is aware of the problems associated with reading these files and is working on a solution to be implemented in a future release of our products."

The file was read into ATC's *MetaView* and displayed. The image appeared to be complete and was acceptable except for font problems with *MetaView*.

The CGM file was reported as meeting the CALS MIL-D-28003 specification.

8. Conclusions and Recommendations

In summary, the tape from Northrop Corporation was correct. The tape could be read properly using both the AFCTN *Tape-tool* and the TI version with no reported errors. The physical structure of the tape meets the CALS MIL-STD-1840A requirements.

The four IGES files on the tape meet the CALS MIL-D-28000A specification.

The DTD contained reference to a file not available in the AFCTB and not referenced in MIL-M-28001A. The DTD also had a reported ambiguous content model. The SGML part of the tape does not meet the CALS MIL-M-28001A specification.

The tape included one Raster files which did not meet the CALS MIL-R-28002A specification. The AFCTN *validg4* utility reported the file as bad and two other utilities were able to read the file but generated an image with many random lines.

The tape contained one CGM file which was reported as meeting the CALS MIL-D-28003 specification.

The tape, because of errors in the SGML and Raster files, does not meet the CALS MIL-STD-1840A requirements.

9. Appendix A - Tapetool Report Logs

9.1 Tape Catalog

Air Force CALS Test Network Catalog Evaluation - Version 1.2; Release Number 8

Standards referenced:

- MIL-STD-1840A (1987) - Automated Interchange of Technical Information
- MIL-R-28003 (1988) - Digital Representation For Communication Of Illustration Data; CGM Application Profile
- ANSI X3.27 (1987) - File Structure and labeling of Magnetic Tapes for Information Interchange
- ANSI X3.4 (1986) - Coded Character Sets - 7 Bit ASCII

Wed Mar 3 14:32:49 1993

MIL-STD-1840A File Catalog

File Set Directory: /cals/tapetool8/Set069

Page: 1

| File Name | File Type | Record Format/ Length | Block Length/Total | Selected/ Extracted |
|-----------|----------------------|-----------------------------|-----------------------|------------------------|
| D001 | Document Declaration | D/00260 | 02048/000001 | Extracted |
| D001T001 | Text | D/00260 | 02048/000009 | Extracted |
| D001G002 | DTD | D/00260 | 02048/000010 | Extracted |
| D001H003 | Output Specification | D/00260 | 02048/000051 | Extracted |
| D001Q004 | IGES | F/00080 | 02000/000281 | Extracted |
| D001Q005 | IGES | F/00080 | 02000/000138 | Extracted |
| D001Q006 | IGES | F/00080 | 02000/000224 | Extracted |
| D001Q007 | IGES | F/00080 | 02000/000224 | Extracted |
| D001C008 | CGM | F/00080 | 00800/000062 | Extracted |
| D001R009 | Raster | F/00128 | 02048/000005 | Extracted |

Catalog Process terminated normally.

9.2 Tape Evaluation Log

Air Force CALS Test Network Tape Evaluation - Version 1.2; Release Number 8

Standards referenced:

ANSI X3.27 (1987) - File Structure and labeling of Magnetic Tapes
for Information Interchange

ANSI X3.4 (1986) - Coded Character Sets - 7 Bit ASCII

Wed Mar 3 14:32:01 1993

ANSI Tape Import Log

Allocating tape drive /dev/rmt0...

/dev/rmt0 allocated.

VOLLITDS01

CONTROLLER

4

Label Identifier: VOL1
Volume Identifier: ITDS01
Volume Accessibility:
Owner Identifier:
Label Standard Version: 4

HDR1D001

ITDS0100010001000100 93057 93057 000000 CONTROLLER

Label Identifier: HDR1
File Identifier: D001
File Set Identifier: ITDS01
File Section Number: 0001
File Sequence Number: 0001
Generation Number: 0001
Generation Version Number: 00
Creation Date: 93057
Expiration Date: 93057
File Accessibility:
Block Count: 000000
Implementation Identifier: CONTROLLER

HDR2D0204800260

00

Label Identifier: HDR2
Recording Format: D
Block Length: 02048
Record Length: 00260
Offset Length: 00

***** Tape Mark *****

Actual Block Size Found = 2048 Bytes.

Number of data blocks read = 1.

***** Tape Mark *****

EOF1D001 ITDS0100010001000100 93057 93057 000001 CONTROLLER

Label Identifier: EOF1
File Identifier: D001
File Set Identifier: ITDS01
File Section Number: 0001
File Sequence Number: 0001
Generation Number: 0001
Generation Version Number: 00
Creation Date: 93057
Expiration Date: 93057
File Accessibility:
Block Count: 000001
Implementation Identifier: CONTROLLER

EOF2D0204800260

00

Label Identifier: EOF2
Recording Format: D
Block Length: 02048
Record Length: 00260
Offset Length: 00

***** Tape Mark *****

HDR1D001T001 ITDS0100010002000100 93057 93057 000000 CONTROLLER

Label Identifier: HDR1
File Identifier: D001T001
File Set Identifier: ITDS01
File Section Number: 0001
File Sequence Number: 0002
Generation Number: 0001
Generation Version Number: 00
Creation Date: 93057
Expiration Date: 93057
File Accessibility:
Block Count: 000000

Implementation Identifier: CONTROLLER

HDR2D0204800260 00

Label Identifier: HDR2
Recording Format: D
Block Length: 02048
Record Length: 00260
Offset Length: 00

***** Tape Mark *****

Actual Block Size Found = 2048 Bytes.

Number of data blocks read = 9.

***** Tape Mark *****

EOF1D001T001 ITDS0100010002000100 93057 93057 000009 CONTROLLER

Label Identifier: EOF1
File Identifier: D001T001
File Set Identifier: ITDS01
File Section Number: 0001
File Sequence Number: 0002
Generation Number: 0001
Generation Version Number: 00
Creation Date: 93057
Expiration Date: 93057
File Accessibility:
Block Count: 000009
Implementation Identifier: CONTROLLER

EOF2D0204800260 00

Label Identifier: EOF2
Recording Format: D
Block Length: 02048
Record Length: 00260
Offset Length: 00

***** Tape Mark *****

<<<< PART OF LOG RMEOVED HERE >>>>

***** Tape Mark *****

Label Identifier: EOF2
Recording Format: F
Block Length: 02048
Record Length: 00128
Offset Length: 00

***** Tape Mark *****

***** Tape Mark *****

End of Volume ITDS01

End Of Tape File Set

Deallocating /dev/rmt0...

Tape Import Process terminated with 0 error(s), 0 warning(s),
and 0 note(s).

9.3 Tape File Set Validation Log

Air Force CALS Test Network File Set Evaluation - Version 1.2; Release Number 8
Standards referenced:

MIL-STD-1840A (1987) - Automated Interchange of Technical Information

MIL-R-28002 (1989) - Raster Graphics Representation In Binary
Format, Requirements For

Wed Mar 3 14:32:49 1993

MIL-STD-1840A File Set Evaluation Log

File Set: Set069

Found file: D001

Extracting Document Declaration Header Records...

Evaluating Document Declaration Header Records...

srcsys: John P. Kent, ITDS Chief Engineer, Northrop Corporation, B-2 Division, L591/GK
E. Washington Blvd., Pico Rivera, CA 90660-3765 (310) 948-0624

srcdocid: 1B-2A-2-21JG-10-1

srcrelid: NONE

chglvl: ORIGINAL

dteisu: 19910301

dstsys: Jeff Fisher, Integration Manager, USAF CALS Test Bed, HQ AFMC (I)/ENCT, Techne
4027 Col. Glenn Highway, Dayton, OH 45431-1601

dstdocid: 1B-2A-2-21JG-10-1

dstrelid: NONE

dtetrn: 19930226

dlvacc: NONE

filcnt: T1, H1, G1, C1, Q4, R1

ttlcls: UNCLASSIFIED

doccls: UNCLASSIFIED

doctyp: JOB GUIDE

doctl: ENVIRONMENTAL CONTROL - ECS CONTROL

Found file: D001T001

Extracting Text Header Records...

Evaluating Text Header Records...

srcdocid: 1B-2A-2-21JG-10-1

dstdocid: 1B-2A-2-21JG-10-1

txtfilid: W

doccls: UNCLASSIFIED

notes: NONE

Saving Text Header File: D001T001_HDR
Saving Text Data File: D001T001_TXT

Found file: D001G002
Extracting DTD Header Records...
Evaluating DTD Header Records...

srcdocid: 1B-2A-2-21JG-10-1
dstdocid: 1B-2A-2-21JG-10-1
notes: NONE

Saving DTD Header File: D001G002_HDR
Saving DTD Data File: D001G002_DTD

Found file: D001H003
Extracting Output Specification Header Records...
Evaluating Output Specification Header Records...

srcdocid: 1B-2A-2-21JG-10-1
dstdocid: 1B-2A-2-21JG-10-1
notes: NONE

Saving Output Specification Header File: D001H003_HDR
Saving Output Specification Data File: D001H003_OS

Found file: D001Q004
Extracting IGES Header Records...
Evaluating IGES Header Records...

srcdocid: 1B-2A-2-21JG-10-1
dstdocid: 1B-2A-2-21JG-10-1
txtfilid: W
figid: NONE
srcgph: B2AJG2111-0101A
doccls: UNCLASSIFIED
notes: NONE

Saving IGES Header File: D001Q004_HDR
Saving IGES Data File: D001Q004_IGS

Found file: D001Q005
Extracting IGES Header Records...
Evaluating IGES Header Records...

srcdocid: 1B-2A-2-21JG-10-1
dstdocid: 1B-2A-2-21JG-10-1
txtfilid: W

figid: NONE
srcgph: B2AJG2112-0101A
doccls: UNCLASSIFIED
notes: NONE

Saving IGES Header File: D001Q005_HDR
Saving IGES Data File: D001Q005_IGS

Found file: D001Q006
Extracting IGES Header Records...
Evaluating IGES Header Records...

srcdocid: 1B-2A-2-21JG-10-1
dstdocid: 1B-2A-2-21JG-10-1
txtfilid: W
figid: NONE
srcgph: B2AJG2112-0109C
doccls: UNCLASSIFIED
notes: NONE

Saving IGES Header File: D001Q006_HDR
Saving IGES Data File: D001Q006_IGS

Found file: D001Q007
Extracting IGES Header Records...
Evaluating IGES Header Records...

srcdocid: 1B-2A-2-21JG-10-1
dstdocid: 1B-2A-2-21JG-10-1
txtfilid: W
figid: NONE
srcgph: B2AJG2112-0110B
doccls: UNCLASSIFIED
notes: NONE

Saving IGES Header File: D001Q007_HDR
Saving IGES Data File: D001Q007_IGS

Found file: D001C008
Extracting CGM Header Records...
Evaluating CGM Header Records...

srcdocid: 1B-2A-2-21JG-10-1
dstdocid: 1B-2A-2-21JG-10-1
txtfilid: W
figid: NONE
srcgph: B2AJG2111-0103D

doccls: UNCLASSIFIED
notes: NONE

Saving CGM Header File: D001C008_HDR
Saving CGM Data File: D001C008_CGM

Found file: D001R009
Extracting Raster Header Records...
Evaluating Raster Header Records...

srcdocid: 1B-2A-2-21JG-10-1
dstdocid: 1B-2A-2-21JG-10-1
txtfilid: W
figid: NONE
srcgph: B2AJG2111-0104D
doccls: UNCLASSIFIED
rtype: 1
rorient: 000,270
rpelcnt: 000312,000500
rdensty: 0300
notes: NONE

Saving Raster Header File: D001R009_HDR
Saving Raster Data File: D001R009_GR4

Evaluating numbering scheme...
No errors were encountered during numbering scheme evaluation.
Numbering scheme evaluation complete.

Checking file count...
No errors were encountered during file count verification.
File Count verification complete.

No errors were encountered in Document D001.

No errors were encountered in this File Set.

MIL-STD-1840A File Set Evaluation Complete.

10. Appendix B - Detailed IGES Analysis

10.1 File Q004

10.1.1 Parser/Verifier Log

```
*** IGES DATA FILE ANALYSIS ***  
***      MARCH 1992      ***  
***   IGES Data Analysis   ***  
***   (708) 449-3430     ***
```

Input file is /novell/9317/q004.igs

Checking conformance to CALS Class I (MIL-D-28000A 2/10/92)

Today is March 4, 1993 4:47 PM

*** File and Product Name Information ***

```
File name from sender   = '0101A.gef.igs'  
File creation Date.Time = '930218.130008'  
Model change Date.Time = ''  
Author                  = 'NORTHROP B2 ITDS CTB'  
Department               = ''  
Product name from sender = '0101A.gef.igs'  
Destination product name = '0101A.gef.igs'
```

*** Parameter Delimiters ***

```
Delimiter = ','  
Terminator = ';' 
```

*** Originating System Data ***

```
System ID           = 'ITDS CONVERTER: GEF_IGES'  
Preprocessor version = '1.0'  
Specification version = 6 (IGES 4.0)
```

*** Precision levels ***

```
Integer bits = 32  
Floating point - Exponent = 38  Mantissa = 6  
Double precision - Exponent = 308  Mantissa = 15
```

*** Global Model Data ***

Model scale = 1.0000E+00
 Unit flag = 1
 Units = 'IN'
 Line weights = 1
 Maximum line thickness = 6.300000E-03
 Minimum line thickness = 6.300000E-03
 CAUTION 2317: Maximum line thickness equal to minimum thickness.
 Granularity = 1.000000E-03
 Maximum coordinate = 7.243750E+00

Drafting standard applicable to original data is not specified.

*** Status Flag Summary ***

| | | |
|---------------|----------------------------|------|
| Blank status: | Visible | 1850 |
| | Blanked | 0 |
| Independence: | Independent | 1838 |
| | Physically Subordinate | 8 |
| | Logically Subordinate | 4 |
| | Totally Subordinate | 0 |
| Entity use: | Geometry | 1831 |
| | Annotation | 19 |
| | Definition | 0 |
| | Other | 0 |
| | Logical/Positional | 0 |
| | 2D parametric | 0 |
| | Not Specified | 0 |
| Hierarchy: | Structure DE applies | 0 |
| | Subordinate DE applies | 1850 |
| | Hierarchy property applies | 0 |
| | Not Specified | 0 |

*** Entity Occurrence Counts ***

| Entity | Form | Level | Count | Type |
|--------|------|-------|-------|----------------------------|
| ----- | ---- | ----- | ----- | ----- |
| 104 | 1 | 0 | 659 | Conic arc - ellipse |
| 106 | 63 | 0 | 8 | Simple closed planar curve |
| 110 | 0 | 0 | 497 | Line |
| 112 | 0 | 0 | 5 | Parametric spline curve |
| 124 | 0 | 0 | 659 | Transformation matrix |
| 212 | 0 | 0 | 9 | General note |

| | | | | |
|-----|----|---|---|---|
| 230 | 0 | 0 | 8 | Sectioned area (Standard Crosshatching) |
| 404 | 0 | 0 | 1 | Drawing |
| 406 | 16 | 0 | 1 | Property - Drawing size |
| 406 | 18 | 0 | 2 | Property - Intercharacter spacing |
| 410 | 0 | 0 | 1 | View - Orthographic parallel |

*** Entity Count by Level ***

| | |
|-------|-------|
| Level | Count |
| 0 | 1850 |

*** Labeling Information ***

0% of the entities are labeled.

Unlabeled 1850

*** Line Fonts Used in Data ***

| | | | | | | | | |
|-----|-----|-----|-----|-----|-----|-----|-----|--------------|
| 100 | 102 | 104 | 106 | 108 | 110 | 112 | 114 | |
| - | - | - | - | - | - | - | - | Undefined |
| - | - | 166 | 8 | - | 42 | 4 | - | Solid |
| - | - | - | - | - | - | - | - | Dashed |
| - | - | 493 | - | - | 455 | 1 | - | Phantom |
| - | - | - | - | - | - | - | - | Center-line |
| - | - | - | - | - | - | - | - | Dotted |
| - | - | - | - | - | - | - | - | User defined |
| 116 | 118 | 120 | 122 | 124 | 125 | 126 | 128 | |
| - | - | - | - | 659 | - | - | - | Undefined |
| - | - | - | - | - | - | - | - | Solid |
| - | - | - | - | - | - | - | - | Dashed |
| - | - | - | - | - | - | - | - | Phantom |
| - | - | - | - | - | - | - | - | Center-line |
| - | - | - | - | - | - | - | - | Dotted |
| - | - | - | - | - | - | - | - | User defined |
| 130 | 132 | 134 | 136 | 138 | 140 | 142 | 144 | |
| - | - | - | - | - | - | - | - | Undefined |
| - | - | - | - | - | - | - | - | Solid |
| - | - | - | - | - | - | - | - | Dashed |
| - | - | - | - | - | - | - | - | Phantom |
| - | - | - | - | - | - | - | - | Center-line |
| - | - | - | - | - | - | - | - | Dotted |

- - - - - User defined

*** Line Widths Used in Data ***

| Weight | Count | Width |
|-----------|-------|----------|
| Defaulted | 1850 | (0.0063) |

*** Colors Used in Data ***

| | |
|-----------|------|
| Defaulted | 1784 |
| Black | 57 |
| White | 9 |

***** ENTITY ANALYSIS *****

*** Entity type: 104

WARNING 2265: Start point off conic by 1.190300E-03 at D 539.
WARNING 2265: Start point off conic by 1.234213E-03 at D 595.
WARNING 2039: Messages regarding conic end points suppressed.

*** Entity type: 106

*** Entity type: 110

-- 497 lines averaging 2.015512E-01 units --

*** Entity type: 112

*** Entity type: 124

659 transformation matrices, 659 non-zero translations.

NOTE 2341: 659 matrices contain translation information.

*** Entity type: 212

9 text strings in data file.
Average text aspect ratio in file is 0.9883842.
Minimum text aspect ratio in file is 0.9821430.
Maximum text aspect ratio in file is 0.9910715.

FONTS USED IN FILE

| FONT | COUNT | NAME |
|------|-------|------|
|------|-------|------|

1 9 Default ASCII Style

*** Entity type: 230

*** Entity type: 404

Drawing at D 5 contains 1 views.

Drawing at D 5 contains 0 annotation entities.

*** Entity type: 406

*** Entity type: 410

Scale of view at D 1 is 1.000000E+00.

Orthographic View entity at D 1 has 0 clipping planes specified.

XMIN = Not Set XMAX = Not Set

YMIN = Not Set YMAX = Not Set

ZMIN = Not Set ZMAX = Not Set

*** Message Summary ***

2015: 98 Mathematically incorrect definitions.

2018: 1 Problems with line weight/width display information.

*** Error Summary ***

0 fatal errors

0 severe errors

0 errors

98 warnings

1 cautions

0 nitpicks

1 notes

*** End of Analysis of /novell/9317/q004.igs ***

10.1.2 Output IGESView

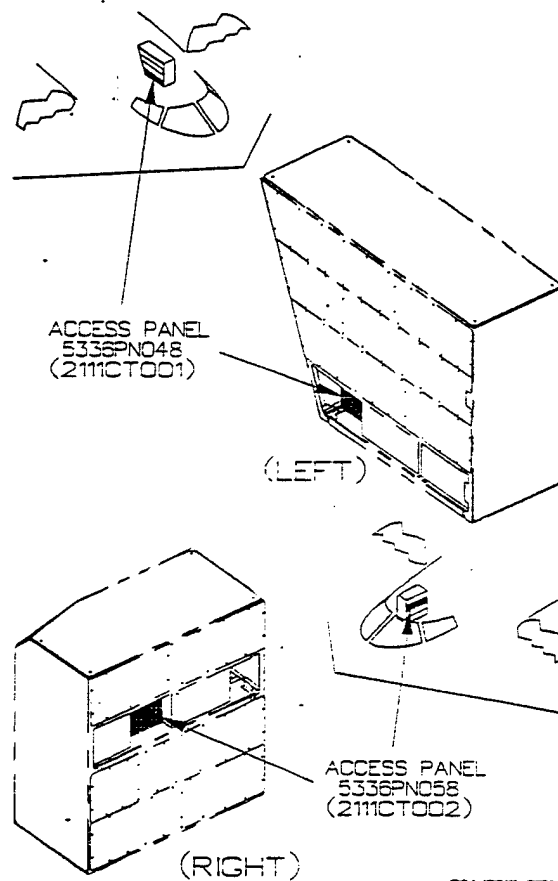

10.1.3 Output IGESWorks

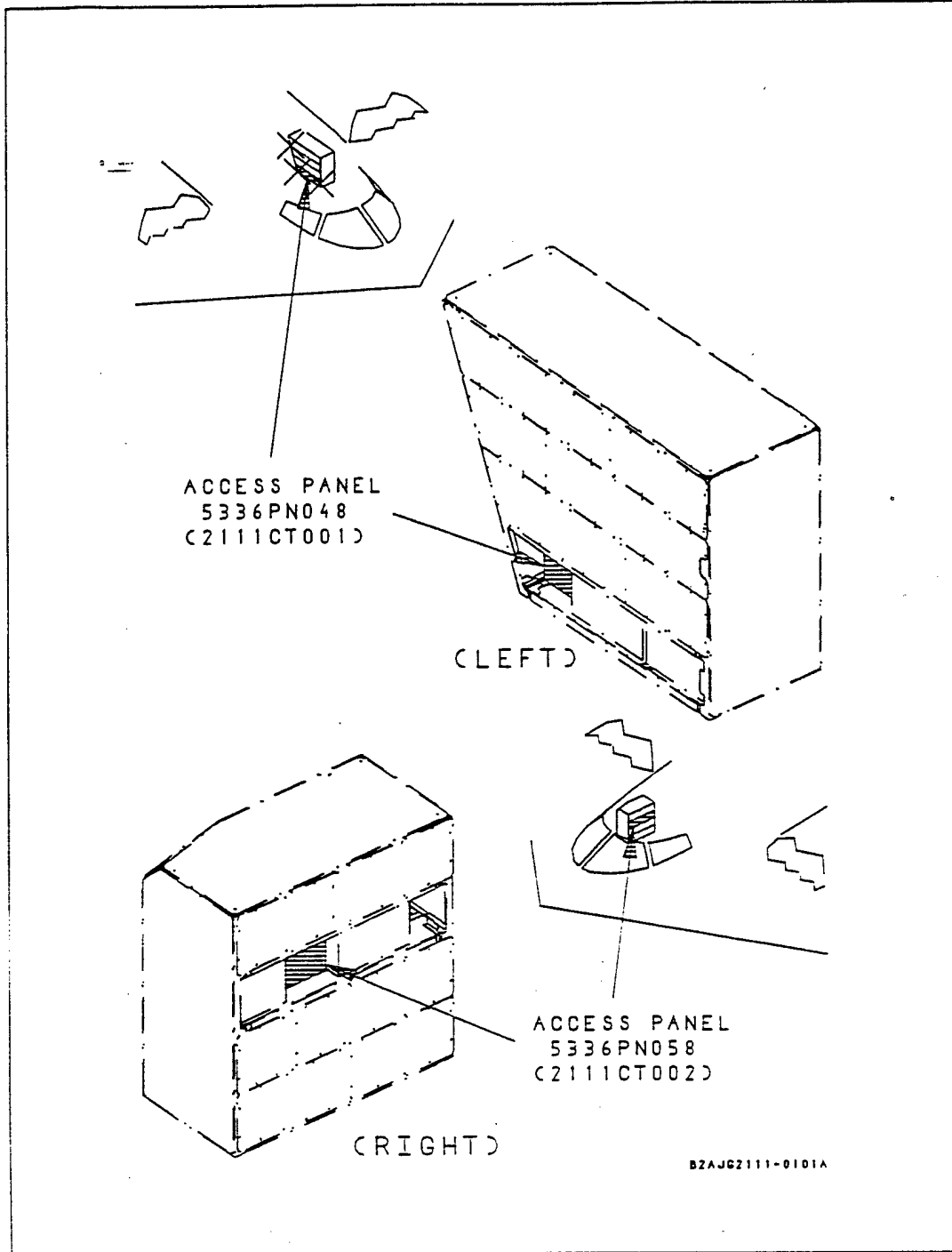

10.1.4 Output Preview

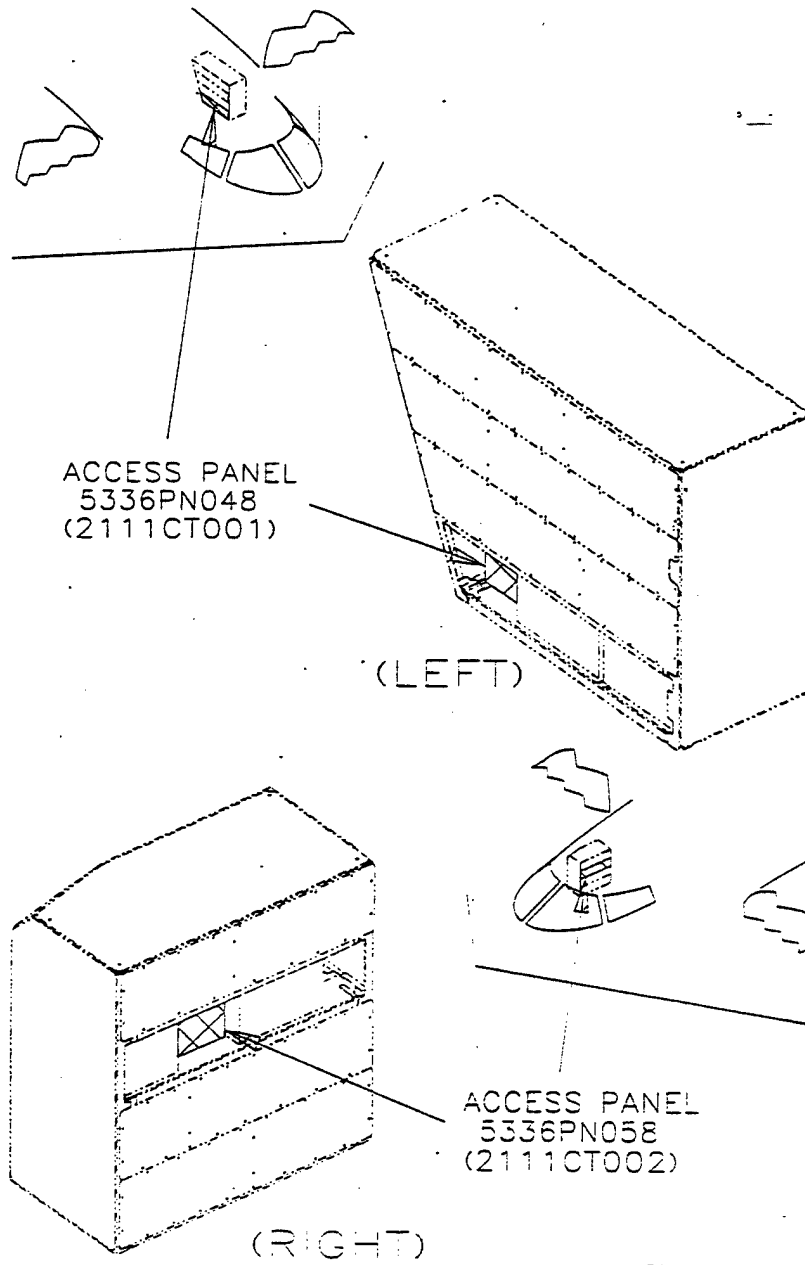

B2AJG2111-0101A

10.2 File Q005

10.2.1 Parser/Verifier Log

```
*** IGES DATA FILE ANALYSIS ***
***      MARCH 1992      ***
***  IGES Data Analysis  ***
***      (708) 449-3430  ***
```

Input file is /novell/9317/q005.igs

Checking conformance to CALS Class I (MIL-D-28000A 2/10/92)

Today is March 4, 1993 4:47 PM

*** File and Product Name Information ***

```
File name from sender   = '0101A.gef.igs'
File creation Date.Time = '930218.130511'
Model change Date.Time  = ''
Author                  = 'NORTHROP B2 ITDS CTB'
Department              = ''
Product name from sender = '0101A.gef.igs'
Destination product name = '0101A.gef.igs'
```

*** Parameter Delimiters ***

```
Delimiter = ','
Terminator = ';'

```

*** Originating System Data ***

```
System ID           = 'ITDS CONVERTER: GEF_IGES'
Preprocessor version = '1.0'
Specification version = 6 (IGES 4.0)
```

*** Precision levels ***

```
Integer bits = 32
Floating point - Exponent = 38  Mantissa = 6
Double precision - Exponent = 308  Mantissa = 15
```

*** Global Model Data ***

```
Model scale          = 1.0000E+00
Unit flag            = 1
```

Units = 'IN'
 Line weights = 1
 Maximum line thickness = 3.937490E-03
 Minimum line thickness = 3.937490E-03
 CAUTION 2317: Maximum line thickness equal to minimum thickness.
 Granularity = 1.000000E-03
 Maximum coordinate = 4.168750E+00

Drafting standard applicable to original data is not specified.

*** Status Flag Summary ***

| | | |
|---------------|----------------------------|-----|
| Blank status: | Visible | 834 |
| | Blanked | 0 |
| Independence: | Independent | 830 |
| | Physically Subordinate | 1 |
| | Logically Subordinate | 3 |
| | Totally Subordinate | 0 |
| Entity use: | Geometry | 830 |
| | Annotation | 4 |
| | Definition | 0 |
| | Other | 0 |
| | Logical/Positional | 0 |
| | 2D parametric | 0 |
| | Not Specified | 0 |
| Hierarchy: | Structure DE applies | 0 |
| | Subordinate DE applies | 834 |
| | Hierarchy property applies | 0 |
| | Not Specified | 0 |

*** Entity Occurrence Counts ***

| Entity | Form | Level | Count | Type |
|--------|------|-------|-------|---|
| ----- | ---- | ----- | ----- | ----- |
| 100 | 0 | 0 | 1 | Circular arc |
| 104 | 1 | 0 | 108 | Conic arc - ellipse |
| 106 | 63 | 0 | 1 | Simple closed planar curve |
| 110 | 0 | 0 | 421 | Line |
| 112 | 0 | 0 | 189 | Parametric spline curve |
| 124 | 0 | 0 | 108 | Transformation matrix |
| 212 | 0 | 0 | 1 | General note |
| 230 | 0 | 0 | 1 | Sectioned area (Standard Crosshatching) |
| 404 | 0 | 0 | 1 | Drawing |

| | | | | |
|-----|----|---|---|-----------------------------------|
| 406 | 16 | 0 | 1 | Property - Drawing size |
| 406 | 18 | 0 | 1 | Property - Intercharacter spacing |
| 410 | 0 | 0 | 1 | View - Orthographic parallel |

*** Entity Count by Level ***

| | |
|-------|-------|
| Level | Count |
| 0 | 834 |

*** Labeling Information ***

0% of the entities are labeled.

Unlabeled 834

*** Line Fonts Used in Data ***

| | | | | | | | | |
|-----|-----|-----|-----|-----|-----|-----|-----|--------------|
| 100 | 102 | 104 | 106 | 108 | 110 | 112 | 114 | |
| - | - | - | - | - | - | - | - | Undefined |
| 1 | - | 108 | 1 | - | 415 | 189 | - | Solid |
| - | - | - | - | - | - | - | - | Dashed |
| - | - | - | - | - | 1 | - | - | Phantom |
| - | - | - | - | - | 5 | - | - | Center-line |
| - | - | - | - | - | - | - | - | Dotted |
| - | - | - | - | - | - | - | - | User defined |
| 116 | 118 | 120 | 122 | 124 | 125 | 126 | 128 | |
| - | - | - | - | 108 | - | - | - | Undefined |
| - | - | - | - | - | - | - | - | Solid |
| - | - | - | - | - | - | - | - | Dashed |
| - | - | - | - | - | - | - | - | Phantom |
| - | - | - | - | - | - | - | - | Center-line |
| - | - | - | - | - | - | - | - | Dotted |
| - | - | - | - | - | - | - | - | User defined |
| 130 | 132 | 134 | 136 | 138 | 140 | 142 | 144 | |
| - | - | - | - | - | - | - | - | Undefined |
| - | - | - | - | - | - | - | - | Solid |
| - | - | - | - | - | - | - | - | Dashed |
| - | - | - | - | - | - | - | - | Phantom |
| - | - | - | - | - | - | - | - | Center-line |
| - | - | - | - | - | - | - | - | Dotted |
| - | - | - | - | - | - | - | - | User defined |

*** Line Widths Used in Data ***

| Weight | Count | Width |
|-----------|-------|----------|
| Defaulted | 834 | (0.0039) |

*** Colors Used in Data ***

| | |
|-----------|-----|
| Defaulted | 118 |
| Black | 715 |
| White | 1 |

***** ENTITY ANALYSIS *****

*** Entity type: 100

*** Entity type: 104

WARNING 2265: Start point off conic by 1.336260E-03 at D 969.
WARNING 2039: End point off conic by 1.336260E-03 at D 969.

<<<< PART OF LOG REMOVED HERE >>>>

*** Entity type: 106

*** Entity type: 110

-- 421 lines averaging 1.199761E-01 units --

*** Entity type: 112

WARNING 2238: Polynomial segment (4) at D 1343 is degenerate.
WARNING 2238: Polynomial segment (1) at D 1487 is degenerate.

<<<< PART OF LOG REMOVED HERE >>>>

*** Entity type: 124

108 transformation matrices, 108 non-zero translations.
NOTE 2341: 108 matrices contain translation information.

*** Entity type: 212

1 text strings in data file.
Average text aspect ratio in file is 0.9873866.

Minimum text aspect ratio in file is 0.9873866.
Maximum text aspect ratio in file is 0.9873866.

FONTS USED IN FILE

| FONT | COUNT | NAME |
|------|-------|-----------------------|
| 1 | 1 | ' Default ASCII Style |

*** Entity type: 230

*** Entity type: 404

Drawing at D 5 contains 1 views.
Drawing at D 5 contains 0 annotation entities.

*** Entity type: 406

*** Entity type: 410

Scale of view at D 1 is 1.000000E+00.
Orthographic View entity at D 1 has 0 clipping planes specified.
XMIN = Not Set XMAX = Not Set
YMIN = Not Set YMAX = Not Set
ZMIN = Not Set ZMAX = Not Set

*** Message Summary ***

2015: 14 Mathematically incorrect definitions.
2018: 1 Problems with line weight/width display information.

*** Error Summary ***

0 fatal errors
0 severe errors
0 errors
14 warnings
1 cautions
0 nitpicks
1 notes

*** End of Analysis of /novell/9317/q005.igs ***

10.2.2 Output IGESView

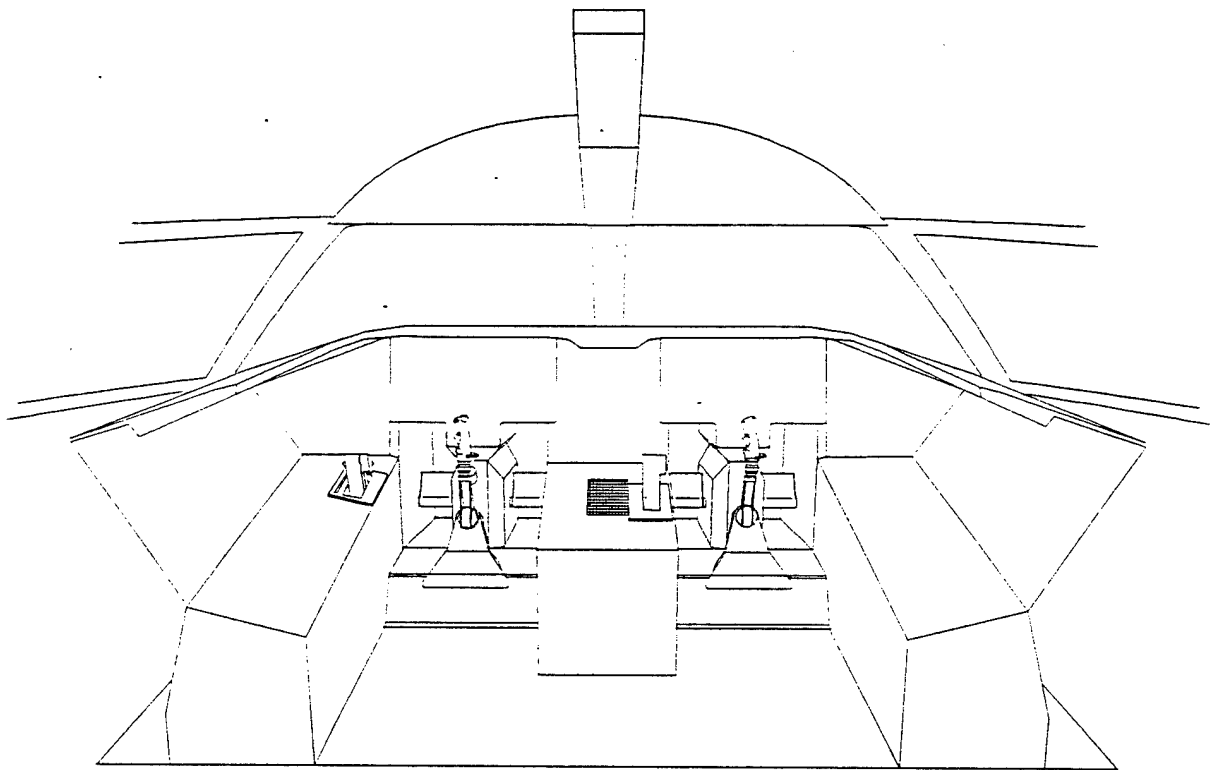

10.2.3 Output IGESWorks

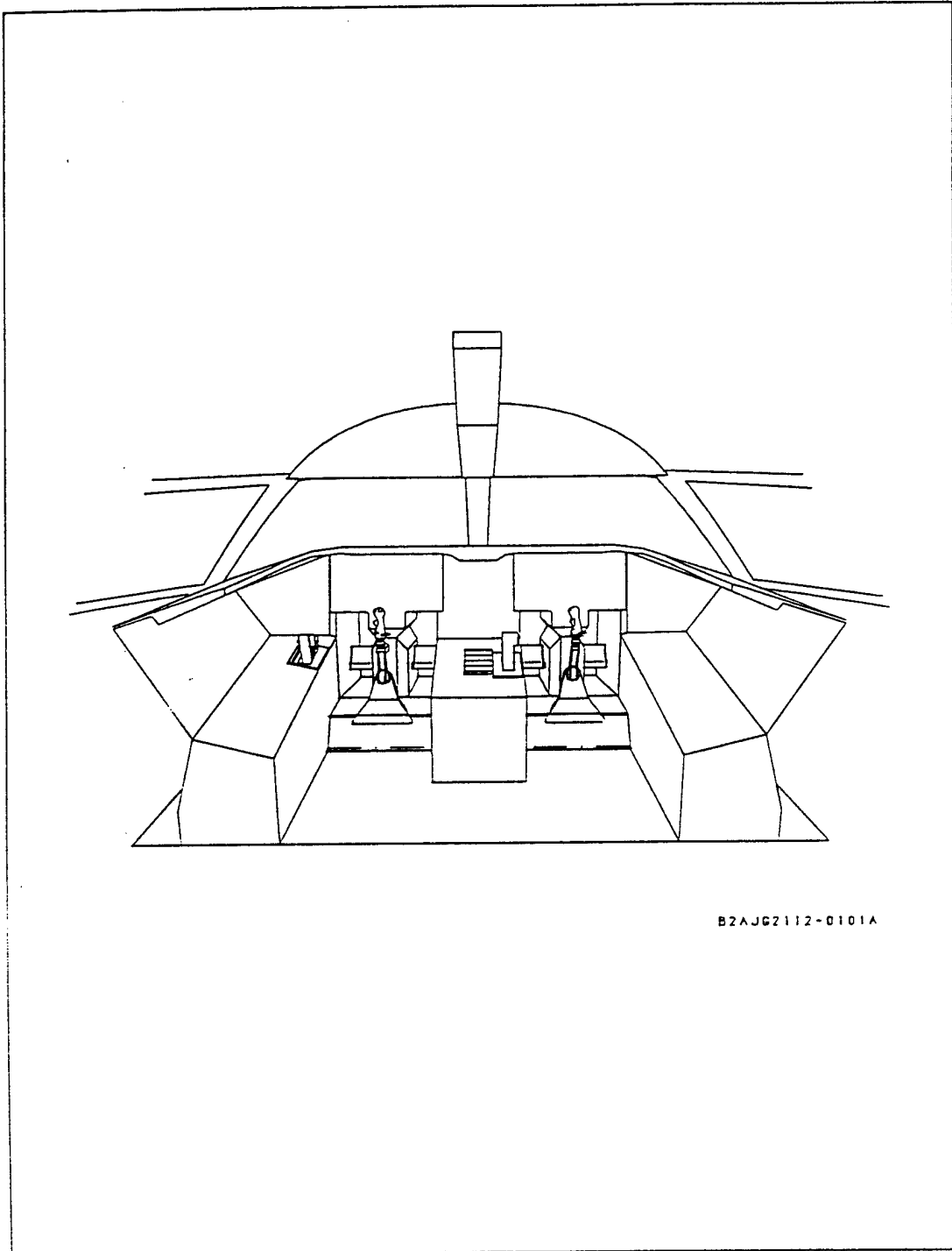

B2AJG2112-0101A

10.2.4 Output Preview

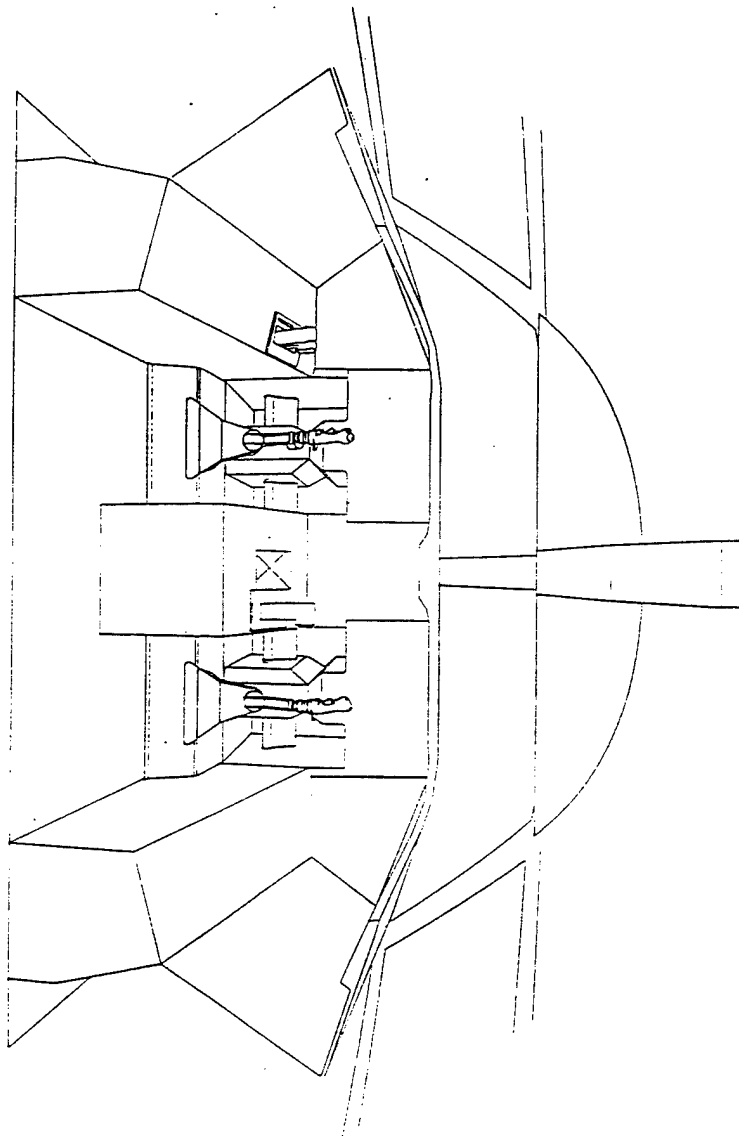

B2AJG2112-0101A

10.3 File Q006

10.3.1 Parser/Verifier Log

```
*** IGES DATA FILE ANALYSIS ***  
***      MARCH 1992      ***  
***  IGES Data Analysis  ***  
***    (708) 449-3430    ***
```

Input file is /novell/9317/q006.igs

Checking conformance to CALS Class I (MIL-D-28000A 2/10/92)

Today is March 4, 1993 4:47 PM

*** File and Product Name Information ***

```
File name from sender      = '0109C.gef.igs'  
File creation Date.Time   = '930218.130525'  
Model change Date.Time    = ''  
Author                    = 'NORTHROP B2 ITDS CTB'  
Department                = ''  
Product name from sender  = '0109C.gef.igs'  
Destination product name = '0109C.gef.igs'
```

*** Parameter Delimiters ***

```
Delimiter = ','  
Terminator = ';' 
```

*** Originating System Data ***

```
System ID          = 'ITDS CONVERTER: GEF_IGES'  
Preprocessor version = '1.0'  
Specification version = 6 (IGES 4.0)
```

*** Precision levels ***

```
Integer bits = 32  
Floating point - Exponent = 38  Mantissa = 6  
Double precision - Exponent = 308  Mantissa = 15
```

*** Global Model Data ***

```
Model scale          = 1.0000E+00  
Unit flag            = 1
```

Units = 'IN'
 Line weights = 1
 Maximum line thickness = 6.300000E-03
 Minimum line thickness = 6.300000E-03
 CAUTION 2317: Maximum line thickness equal to minimum thickness.
 Granularity = 1.000000E-03
 Maximum coordinate = 7.243750E+00

Drafting standard applicable to original data is not specified.

*** Status Flag Summary ***

| | | |
|---------------|----------------------------|------|
| Blank status: | Visible | 1432 |
| | Blanked | 0 |
| Independence: | Independent | 1422 |
| | Physically Subordinate | 6 |
| | Logically Subordinate | 4 |
| | Totally Subordinate | 0 |
| Entity use: | Geometry | 1417 |
| | Annotation | 15 |
| | Definition | 0 |
| | Other | 0 |
| | Logical/Positional | 0 |
| | 2D parametric | 0 |
| | Not Specified | 0 |
| Hierarchy: | Structure DE applies | 0 |
| | Subordinate DE applies | 1432 |
| | Hierarchy property applies | 0 |
| | Not Specified | 0 |

*** Entity Occurrence Counts ***

| Entity | Form | Level | Count | Type |
|--------|------|-------|-------|---|
| ----- | ---- | ----- | ----- | ---- |
| 100 | 0 | 0 | 11 | Circular arc |
| 104 | 1 | 0 | 266 | Conic arc - ellipse |
| 106 | 63 | 0 | 6 | Simple closed planar curve |
| 110 | 0 | 0 | 676 | Line |
| 112 | 0 | 0 | 189 | Parametric spline curve |
| 124 | 0 | 0 | 266 | Transformation matrix |
| 212 | 0 | 0 | 7 | General note |
| 230 | 0 | 0 | 6 | Sectioned area (Standard Crosshatching) |
| 404 | 0 | 0 | 1 | Drawing |

| | | | | |
|-----|----|---|---|-----------------------------------|
| 406 | 16 | 0 | 1 | Property - Drawing size |
| 406 | 18 | 0 | 2 | Property - Intercharacter spacing |
| 410 | 0 | 0 | 1 | View - Orthographic parallel |

*** Entity Count by Level ***

| | |
|-------|-------|
| Level | Count |
| 0 | 1432 |

*** Labeling Information ***

0% of the entities are labeled.

Unlabeled 1432

*** Line Fonts Used in Data ***

| | | | | | | | | |
|-----|-----|-----|-----|-----|-----|-----|-----|--------------|
| 100 | 102 | 104 | 106 | 108 | 110 | 112 | 114 | |
| - | - | - | - | - | - | - | - | Undefined |
| 11 | - | 252 | 6 | - | 600 | 189 | - | Solid |
| - | - | 1 | - | - | 19 | - | - | Dashed |
| - | - | 13 | - | - | 50 | - | - | Phantom |
| - | - | - | - | - | 7 | - | - | Center-line |
| - | - | - | - | - | - | - | - | Dotted |
| - | - | - | - | - | - | - | - | User defined |
| 116 | 118 | 120 | 122 | 124 | 125 | 126 | 128 | |
| - | - | - | - | 266 | - | - | - | Undefined |
| - | - | - | - | - | - | - | - | Solid |
| - | - | - | - | - | - | - | - | Dashed |
| - | - | - | - | - | - | - | - | Phantom |
| - | - | - | - | - | - | - | - | Center-line |
| - | - | - | - | - | - | - | - | Dotted |
| - | - | - | - | - | - | - | - | User defined |
| 130 | 132 | 134 | 136 | 138 | 140 | 142 | 144 | |
| - | - | - | - | - | - | - | - | Undefined |
| - | - | - | - | - | - | - | - | Solid |
| - | - | - | - | - | - | - | - | Dashed |
| - | - | - | - | - | - | - | - | Phantom |
| - | - | - | - | - | - | - | - | Center-line |
| - | - | - | - | - | - | - | - | Dotted |
| - | - | - | - | - | - | - | - | User defined |

*** Line Widths Used in Data ***

| Weight | Count | Width |
|-----------|-------|----------|
| Defaulted | 1432 | (0.0063) |

*** Colors Used in Data ***

| | |
|-----------|-----|
| Defaulted | 647 |
| Black | 778 |
| White | 7 |

***** ENTITY ANALYSIS *****

*** Entity type: 100

*** Entity type: 104

WARNING 2265: Start point off conic by 4.023317E-03 at D 953.
WARNING 2039: End point off conic by 4.023317E-03 at D 953.
WARNING 2265: Messages regarding invalid start point suppressed.
WARNING 2039: Messages regarding conic end points suppressed.

*** Entity type: 106

*** Entity type: 110

-- 676 lines averaging 1.383460E-01 units --

*** Entity type: 112

WARNING 2238: Polynomial segment (0) at D 1345 is degenerate.
WARNING 2238: Polynomial segment (1) at D 1423 is degenerate.
WARNING 2238: Polynomial segment (1) at D 1561 is degenerate.
WARNING 2238: Polynomial segment (0) at D 1563 is degenerate.
WARNING 2238: Polynomial segment (0) at D 1645 is degenerate.

*** Entity type: 124

266 transformation matrices, 266 non-zero translations.
NOTE 2341: 266 matrices contain translation information.

*** Entity type: 212

7 text strings in data file.

Average text aspect ratio in file is 0.9608803.
Minimum text aspect ratio in file is 0.8928572.
Maximum text aspect ratio in file is 0.9923470.

FONTS USED IN FILE

| FONT | COUNT | NAME |
|------|-------|---------------------|
| 1 | 7 | Default ASCII Style |

*** Entity type: 230

*** Entity type: 404

Drawing at D 5 contains 1 views.

Drawing at D 5 contains 0 annotation entities.

*** Entity type: 406

*** Entity type: 410

Scale of view at D 1 is 1.000000E+00.

Orthographic View entity at D 1 has 0 clipping planes specified.

XMIN = Not Set XMAX = Not Set

YMIN = Not Set YMAX = Not Set

ZMIN = Not Set ZMAX = Not Set

*** Message Summary ***

2015: 39 Mathematically incorrect definitions.

2018: 1 Problems with line weight/width display information.

*** Error Summary ***

0 fatal errors

0 severe errors

0 errors

39 warnings

1 cautions

0 nitpicks

1 notes

*** End of Analysis of /novell/9317/q006.igs ***

10.3.2 Output IGESView

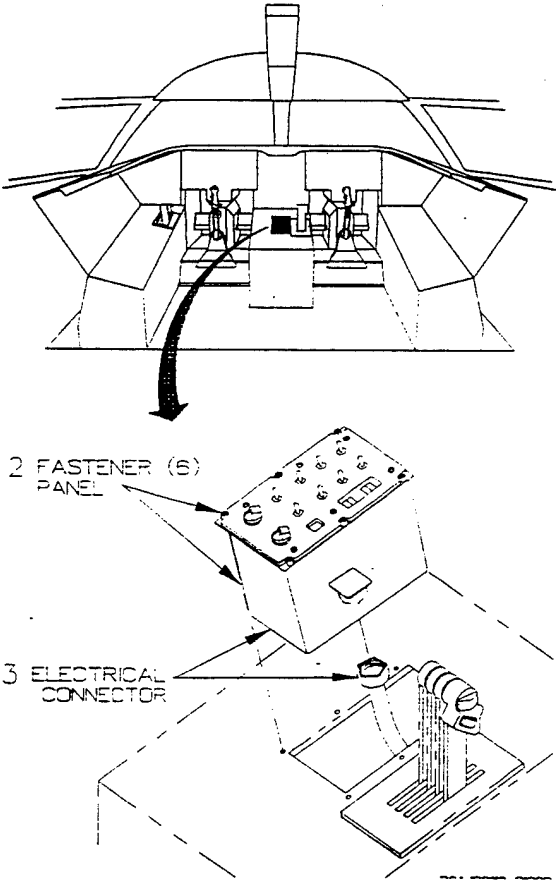

10.3.3 Output IGESWorks

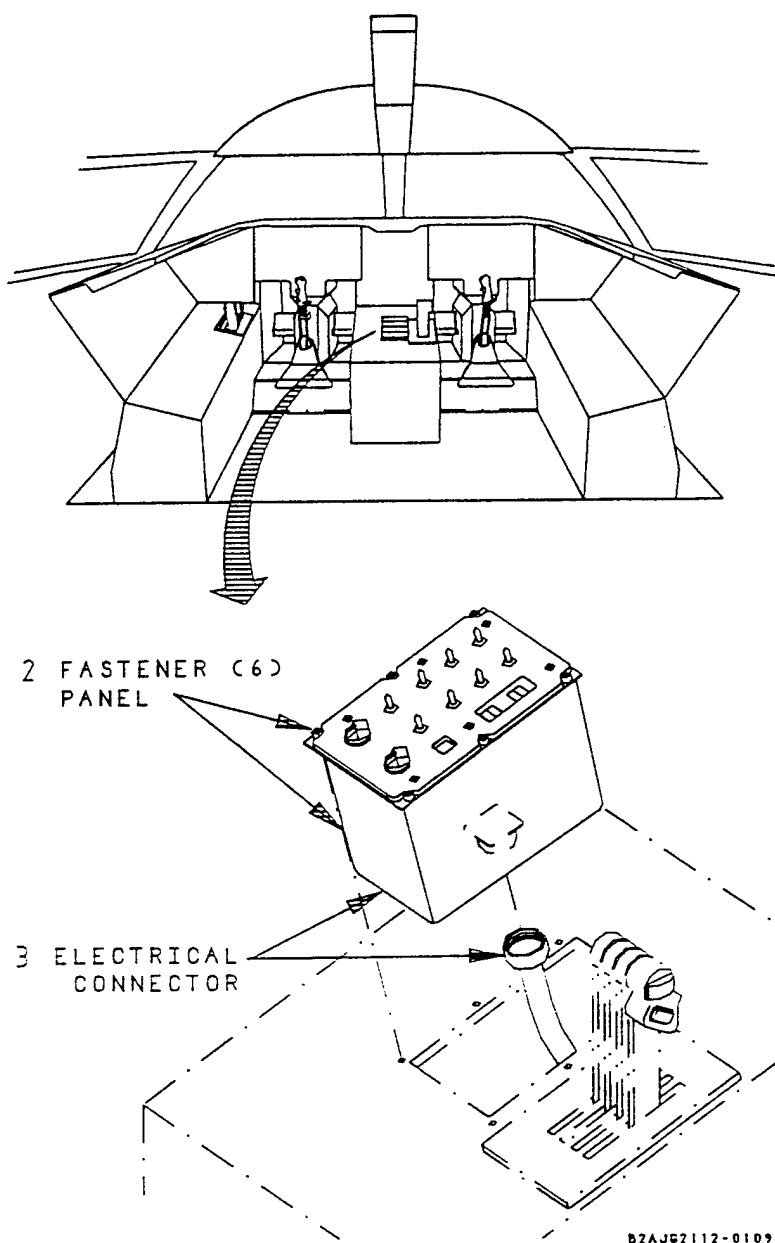

B2AJG2112-0109C

10.3.4 Output Preview

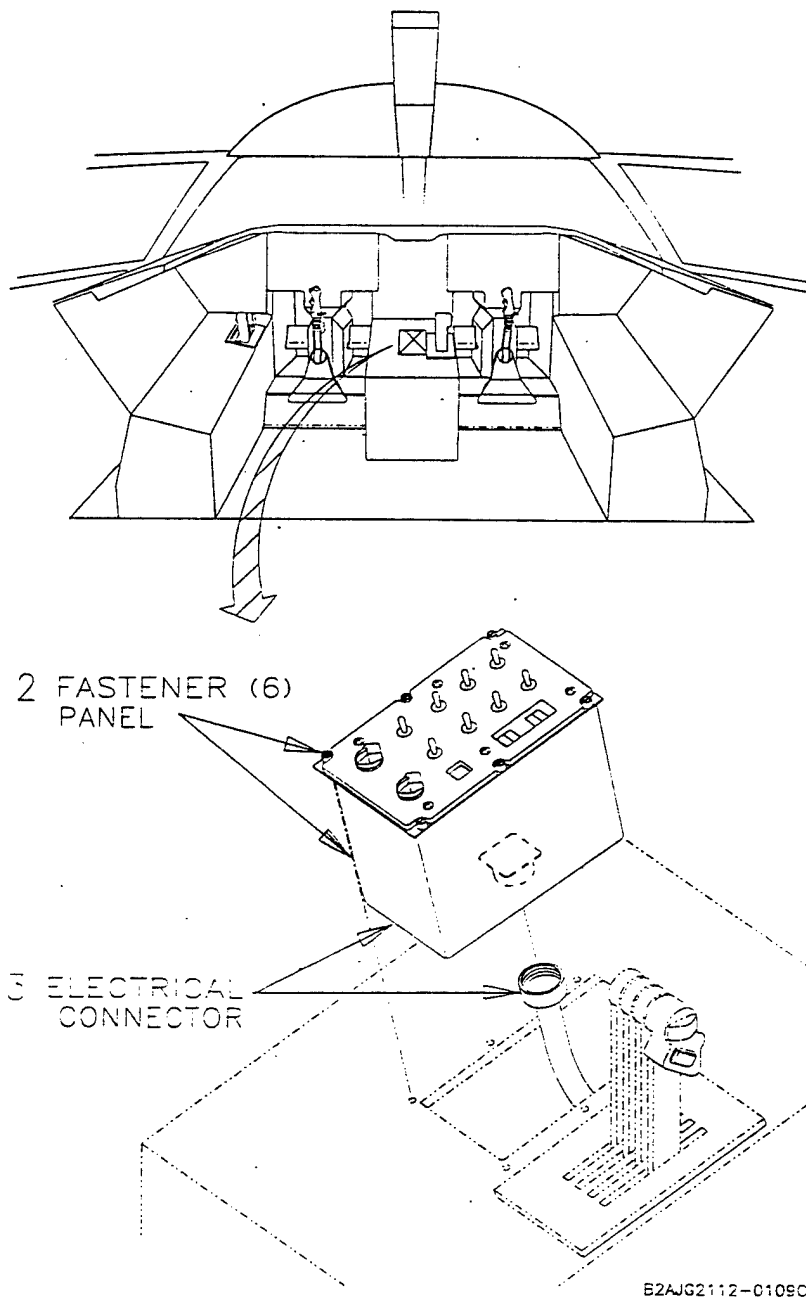

10.4 File Q007

10.4.1 Parser/Verifier Log

```
*** IGES DATA FILE ANALYSIS ***  
***      MARCH 1992      ***  
***   IGES Data Analysis   ***  
***   (708) 449-3430     ***
```

Input file is /novell/9317/q007.igs

Checking conformance to CALS Class I (MIL-D-28000A 2/10/92)

Today is March 4, 1993 4:48 PM

*** File and Product Name Information ***

```
File name from sender      = '0110B.gef.igs'  
File creation Date.Time   = '930218.130543'  
Model change Date.Time   = ''  
Author                    = 'NORTHROP B2 ITDS CTB'  
Department                = ''  
Product name from sender  = '0110B.gef.igs'  
Destination product name = '0110B.gef.igs'
```

*** Parameter Delimiters ***

```
Delimiter = ','  
Terminator = ';' 
```

*** Originating System Data ***

```
System ID          = 'ITDS CONVERTER: GEF_IGES'  
Preprocessor version = '1.0'  
Specification version = 6 (IGES 4.0)
```

*** Precision levels ***

```
Integer bits = 32  
Floating point - Exponent = 38  Mantissa = 6  
Double precision - Exponent = 308  Mantissa = 15
```

*** Global Model Data ***

```
Model scale          = 1.0000E+00  
Unit flag           = 1
```

Units = 'IN'
 Line weights = 1
 Maximum line thickness = 6.300000E-03
 Minimum line thickness = 6.300000E-03
 CAUTION 2317: Maximum line thickness equal to minimum thickness.
 Granularity = 1.000000E-03
 Maximum coordinate = 7.243750E+00

Drafting standard applicable to original data is not specified.

*** Status Flag Summary ***

| | | |
|---------------|----------------------------|------|
| Blank status: | Visible | 1433 |
| | Blanked | 0 |
| Independence: | Independent | 1423 |
| | Physically Subordinate | 6 |
| | Logically Subordinate | 4 |
| | Totally Subordinate | 0 |
| Entity use: | Geometry | 1417 |
| | Annotation | 16 |
| | Definition | 0 |
| | Other | 0 |
| | Logical/Positional | 0 |
| | 2D parametric | 0 |
| | Not Specified | 0 |
| Hierarchy: | Structure DE applies | 0 |
| | Subordinate DE applies | 1433 |
| | Hierarchy property applies | 0 |
| | Not Specified | 0 |

*** Entity Occurrence Counts ***

| Entity | Form | Level | Count | Type |
|--------|------|-------|-------|---|
| ----- | ---- | ----- | ----- | ----- |
| 100 | 0 | 0 | 11 | Circular arc |
| 104 | 1 | 0 | 266 | Conic arc - ellipse |
| 106 | 63 | 0 | 6 | Simple closed planar curve |
| 110 | 0 | 0 | 676 | Line |
| 112 | 0 | 0 | 189 | Parametric spline curve |
| 124 | 0 | 0 | 266 | Transformation matrix |
| 212 | 0 | 0 | 8 | General note |
| 230 | 0 | 0 | 6 | Sectioned area (Standard Crosshatching) |
| 404 | 0 | 0 | 1 | Drawing |

| | | | | |
|-----|----|---|---|-----------------------------------|
| 406 | 16 | 0 | 1 | Property - Drawing size |
| 406 | 18 | 0 | 2 | Property - Intercharacter spacing |
| 410 | 0 | 0 | 1 | View - Orthographic parallel |

*** Entity Count by Level ***

| | |
|-------|-------|
| Level | Count |
| 0 | 1433 |

*** Labeling Information ***

0% of the entities are labeled.

Unlabeled 1433

*** Line Fonts Used in Data ***

| | | | | | | | | |
|-----|-----|-----|-----|-----|-----|-----|-----|--------------|
| 100 | 102 | 104 | 106 | 108 | 110 | 112 | 114 | |
| - | - | - | - | - | - | - | - | Undefined |
| 11 | - | 252 | 6 | - | 600 | 189 | - | Solid |
| - | - | 1 | - | - | 19 | - | - | Dashed |
| - | - | 13 | - | - | 50 | - | - | Phantom |
| - | - | - | - | - | 7 | - | - | Center-line |
| - | - | - | - | - | - | - | - | Dotted |
| - | - | - | - | - | - | - | - | User defined |
| 116 | 118 | 120 | 122 | 124 | 125 | 126 | 128 | |
| - | - | - | - | 266 | - | - | - | Undefined |
| - | - | - | - | - | - | - | - | Solid |
| - | - | - | - | - | - | - | - | Dashed |
| - | - | - | - | - | - | - | - | Phantom |
| - | - | - | - | - | - | - | - | Center-line |
| - | - | - | - | - | - | - | - | Dotted |
| - | - | - | - | - | - | - | - | User defined |
| 130 | 132 | 134 | 136 | 138 | 140 | 142 | 144 | |
| - | - | - | - | - | - | - | - | Undefined |
| - | - | - | - | - | - | - | - | Solid |
| - | - | - | - | - | - | - | - | Dashed |
| - | - | - | - | - | - | - | - | Phantom |
| - | - | - | - | - | - | - | - | Center-line |
| - | - | - | - | - | - | - | - | Dotted |
| - | - | - | - | - | - | - | - | User defined |

*** Line Widths Used in Data ***

| Weight | Count | Width |
|-----------|-------|----------|
| Defaulted | 1433 | (0.0063) |

*** Colors Used in Data ***

| | |
|-----------|-----|
| Defaulted | 647 |
| Black | 778 |
| White | 8 |

***** ENTITY ANALYSIS *****

*** Entity type: 100

*** Entity type: 104

WARNING 2265: Start point off conic by 4.023317E-03 at D 955.
WARNING 2039: End point off conic by 4.023317E-03 at D 955.
WARNING 2265: Messages regarding invalid start point suppressed.
WARNING 2039: Messages regarding conic end points suppressed.

*** Entity type: 106

*** Entity type: 110

-- 676 lines averaging 1.380248E-01 units --

*** Entity type: 112

WARNING 2238: Polynomial segment (0) at D 1351 is degenerate.
WARNING 2238: Polynomial segment (1) at D 1421 is degenerate.
WARNING 2238: Polynomial segment (0) at D 1467 is degenerate.
WARNING 2238: Polynomial segment (1) at D 1567 is degenerate.
WARNING 2238: Polynomial segment (0) at D 1627 is degenerate.

*** Entity type: 124

266 transformation matrices, 266 non-zero translations.

NOTE 2341: 266 matrices contain translation information.

*** Entity type: 212

8 text strings in data file.

Average text aspect ratio in file is 0.9635382.
Minimum text aspect ratio in file is 0.8928572.
Maximum text aspect ratio in file is 0.9923470.

FONTS USED IN FILE

| FONT | COUNT | NAME |
|------|-------|---------------------|
| 1 | 8 | Default ASCII Style |

*** Entity type: 230

*** Entity type: 404

Drawing at D 5 contains 1 views.
Drawing at D 5 contains 0 annotation entities.

*** Entity type: 406

*** Entity type: 410

Scale of view at D 1 is 1.000000E+00.
Orthographic View entity at D 1 has 0 clipping planes specified.
XMIN = Not Set XMAX = Not Set
YMIN = Not Set YMAX = Not Set
ZMIN = Not Set ZMAX = Not Set

*** Message Summary ***

2015: 39 Mathematically incorrect definitions.
2018: 1 Problems with line weight/width display information.

*** Error Summary ***

0 fatal errors
0 severe errors
0 errors
39 warnings
1 cautions
0 nitpicks
1 notes

*** End of Analysis of /novell/9317/q007.igs ***

10.4.2 Output IGESView

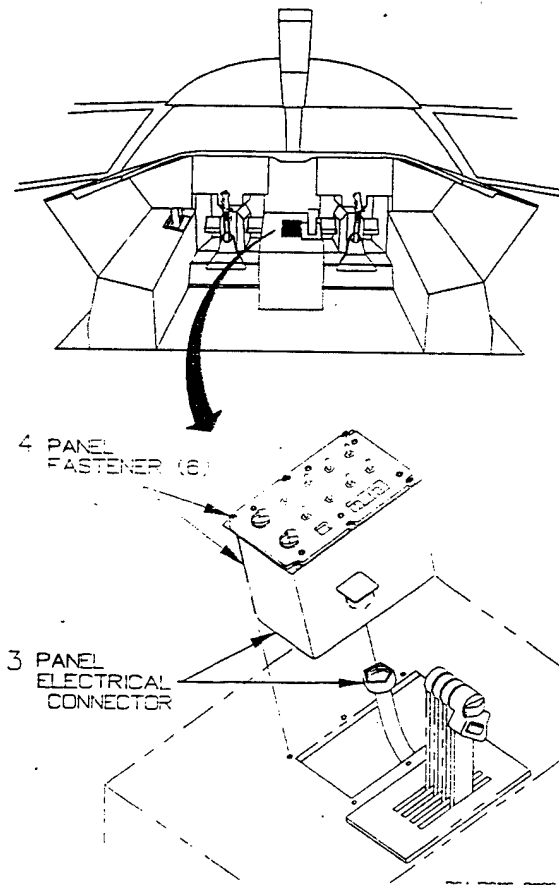

10.4.3 Output IGESWorks

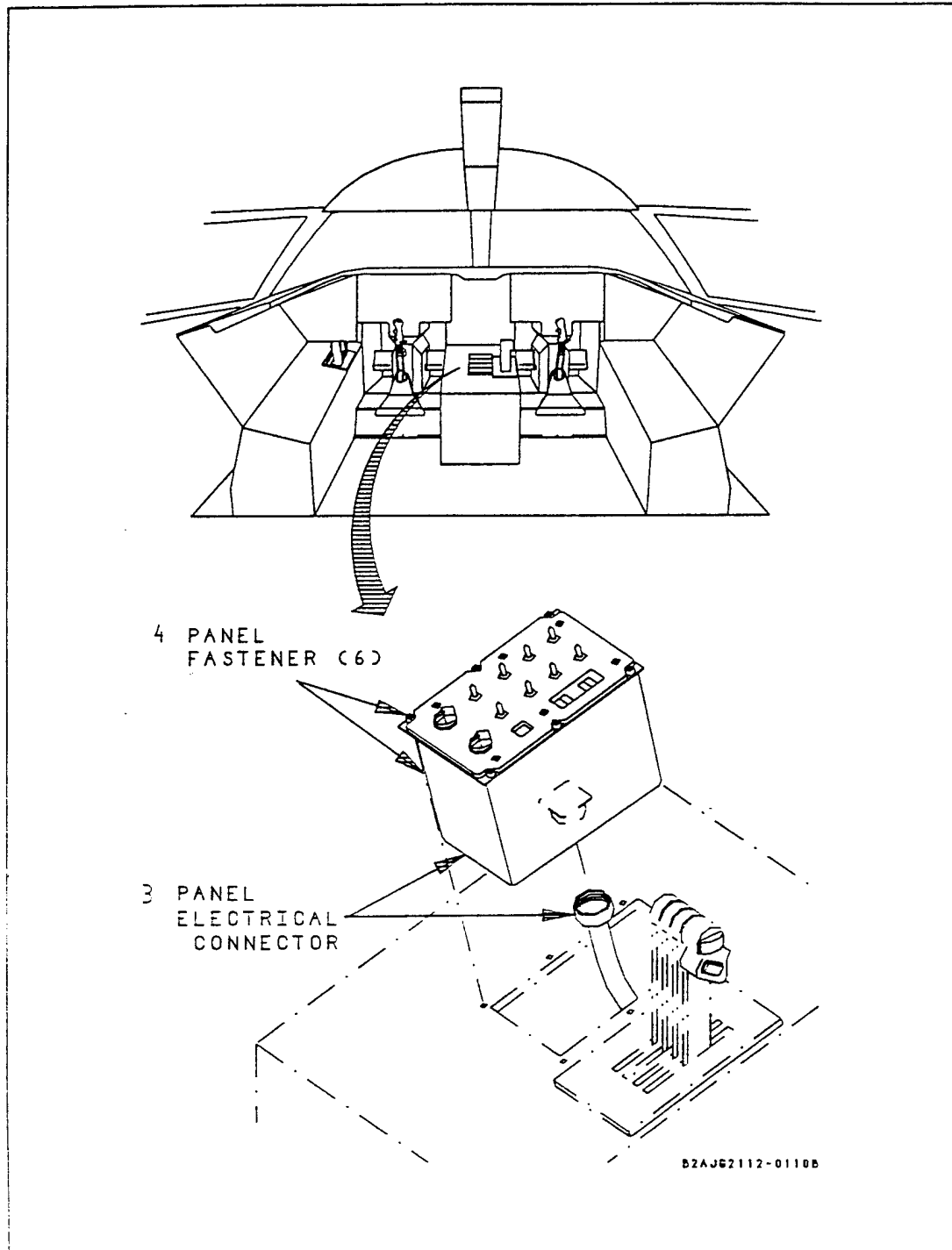

10.4.4 Output Preview

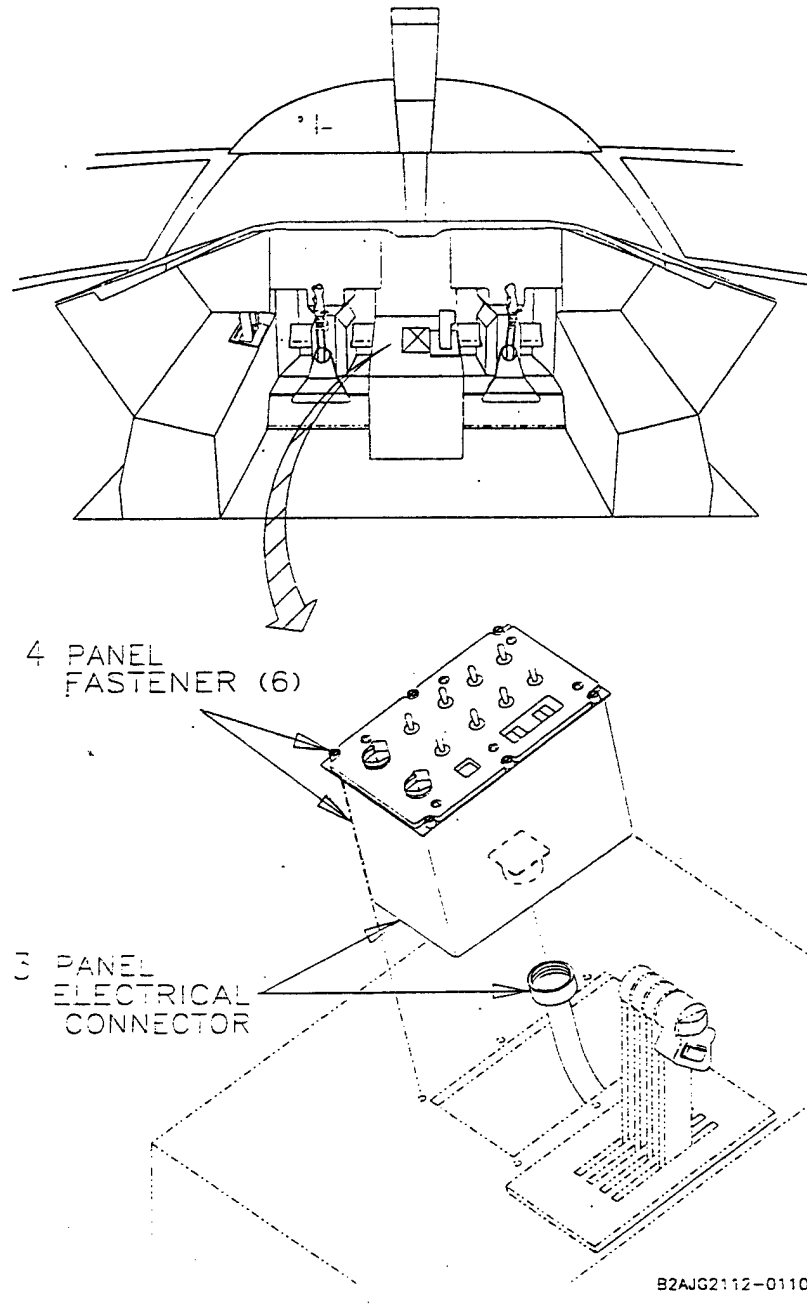

B2AJG2112-0110E

11. Appendix C - Detailed SGML Analysis

11.1 Parser Log

11.1.1 DTD Log

SGML Document Type Definition Parser
An SGML System Conforming to
International Standard ISO 8879
Standard Generalized Markup Language

Log file: '9317.LOG'
SDO File: 'ctndocl.sdo'
Namecase General is yes.
Namecase Entity is no.
Parsing DTD file: '9317.dtd'

This DTD conforms to the ISO 8879 standard

DTO file '9317.DTO' created

closing statistics:
Capacity points: 27360
Bytes of DTO file string space: 7904
SGML descriptor blocks: 2986

Document Type Definition is compliant and parsed normally.

Program status code: 0.

11.1.2 Text Log

IPA0108: *** SGML Instance Parser Log File *** Source Document File: '9317.txt'
File: '9317.jbf'. DTD File: ''. SGML Declaration File: ''.

Reading File '9317.jbf', File Type 'JOB FILE'.

Concrete Syntax Settings In Effect For This Parse: NAMECASE GENERAL: YES. NAMECAS
ENTITY: NO. NAMELEN: 32. SHORTTAG: YES. Closed '9317.jbf',
Type 'JOB FILE'. Reading File '9317.txt', File Type 'DIRECT INPUT FILE'.

--> Scanned Up To Line 100 In 9317.txt. --> Scanned Up To Line 200 In 9317.txt. --> Scanned Up To Line 300 In 9317.txt. --> Scanned Up To Line 400 In 9317.txt. --> Scanned Up To Line 500 In 9317.txt. Closed '9317.txt', File Type 'DIRECT INPUT FILE'. Document Parsed Successfully, No Errors or Warnings.

11.2 Exoterica Parser

11.2.1 First Pass - DTD

```
C:\XGML\XGMLNORM.EXE --
Error on line 34 in file entities/9317.dtd:
Invalid file specification (external identifier).
For the entity 'PUBspc':
The system id is "".
The public id is "ISO 8879-1986//ENTITIES Te ...".
```

11.2.2 Second Pass - DTD

```
C:\XGML\XGMLNORM.EXE --
Error on line 467 in file entities/9317.dtd:
A content model is ambiguous.
For element 'TOC'. The input is 'CONTENTSENTRY'.
<!-- The document prolog is in error. -->
```

11.3 sgmls Parser Log

sgmls: SGML error at 9317.dtd, line 470 in declaration parameter 4:

```
Content model is ambiguous
TOTALCAP 51541/200000
  ENTCAP 7648/200000
ENTCHCAP 3873/200000
  ELEMCAP 3456/200000
  GRPCAP 20320/200000
EXGRPCAP 256/200000
  EXNMCAP 544/200000
  ATTCAP 10752/200000
ATTCHCAP 296/200000
AVGRPCAP 3840/200000
  NOTCAP 192/200000
NOTCHCAP 364/200000
```

12. Appendix D - Detailed Raster Analysis

12.1 File R009

12.1.1 Output g42tiff/IslandPaint

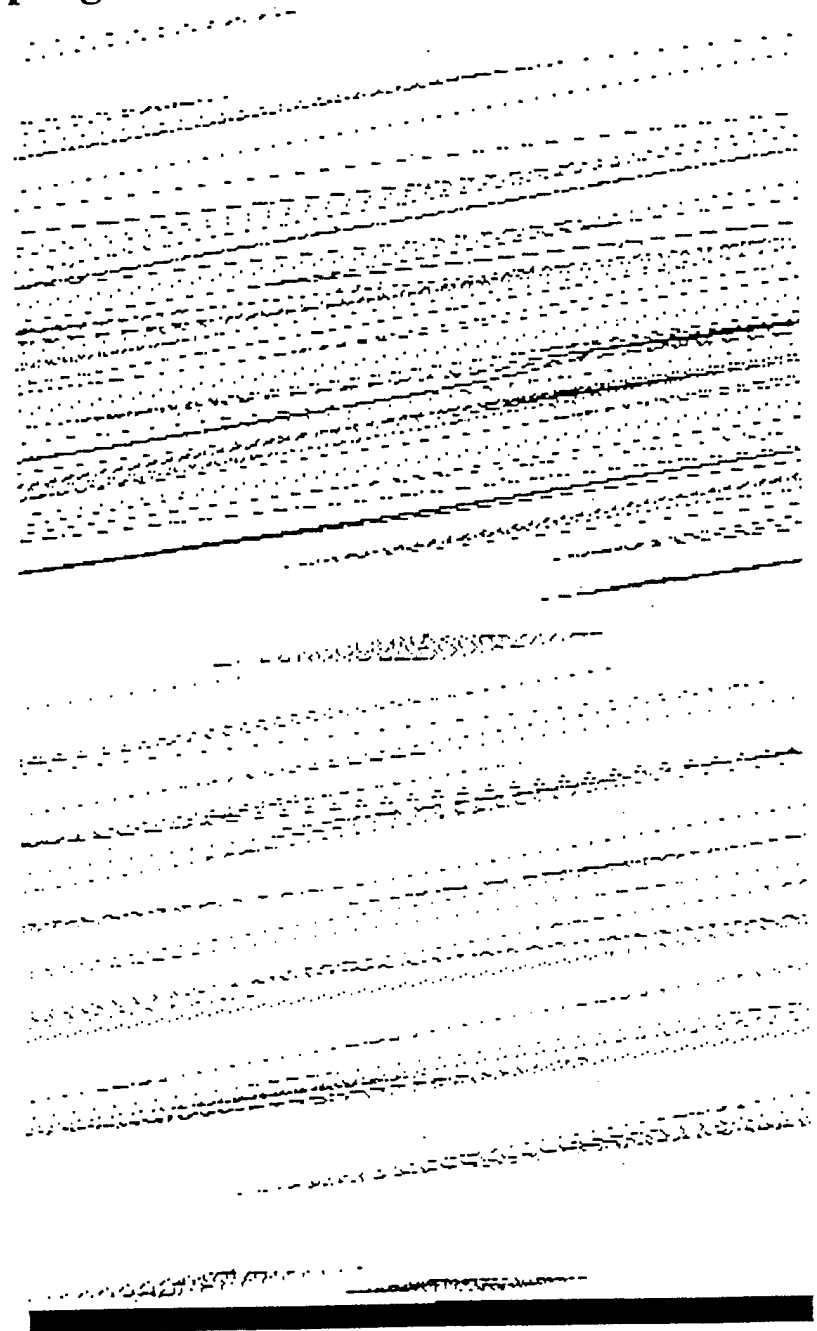

12.1.2 Output HiJaak for Windows

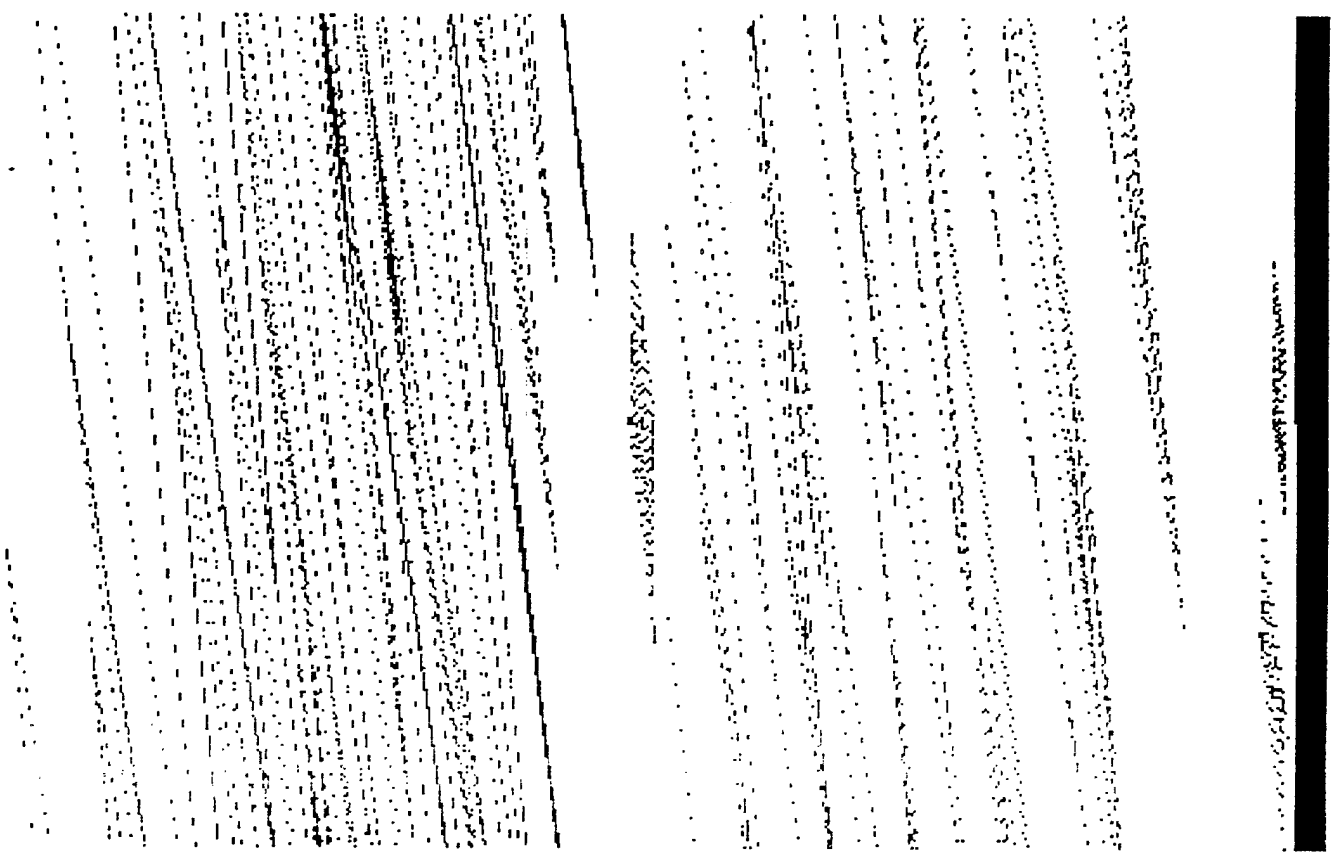

13. Appendix E - Detailed CGM Analysis

13.1 File C008

13.1.1 Parser Log MetaCheck

MetaCheck Version 2.05 -- CGM/MIL-D-28003 Conformance Analyzer
Copyright 1988-91 CGM Technology Software
Execution Date: 03/04/93 Time: 15:49:06

Metafile Examined : i:\9317\c008.cgm

Pictures Examined : All
Elements Examined : All
Bytes Examined : All

=====
Trace Report
=====

Tracing not selected.

=====
CGM Conformance Violation Report
=====

No Errors Detected

=====
CALC CGM Profile (MIL-D-28003) Report
=====

No profile discrepancies detected.

=====
Conformance Summary Report
=====

MetaCheck Version 2.05 -- CGM/MIL-D-28003 Conformance Analyzer
Copyright 1988-91 CGM Technology Software
Execution Date: 03/04/93 Time: 15:49:12

Name of CGM under test: i:\9317\c008.cgm
Encoding : Binary

Pictures Examined : All
Elements Examined : All
Bytes Examined : All

BEGIN METAFILE string : "0103D.cgm"
METAFILE DESCRIPTION : "NORTHROP B2 ITDS GEF, MIL-D-28003/BASIC-1"

Picture 1 starts at octet offset 154; string contains: "Picture 1"

Private values encountered in CGM

Conformance Summary : This file conforms to the CGM specification.

This file meets the CALS CGM Profile (MIL-D-28003).

Summary of Testing performed and Errors Found:

1 Pictures Tested
2192 Elements Tested
48616 Octets Tested

```
=====
| No Errors Were Detected |
=====
```

=====
===== End of Conformance Report =====

13.1.2 validcgm Log

Analysis for file c008.cgm using table table
ERROR: illegal in this state (2), std B
ERROR: required precursor (0, 4) not yet seen
(14.1, 0) (3, 6, 2) Clip Indicator OFF
(0, 1) occurred 1 time
(0, 2) occurred 1 time
(0, 3) occurred 1 time
(0, 4) occurred 1 time
(0, 5) occurred 1 time
(1, 1) occurred 1 time
(1, 2) occurred 1 time
(1, 3) occurred 1 time
(1, 4) occurred 1 time
(1, 5) occurred 1 time
(1, 6) occurred 1 time
(1, 7) occurred 1 time
(1, 8) occurred 1 time
(1, 9) occurred 1 time
(1, 10) occurred 1 time
(1, 11) occurred 1 time
(1, 12) occurred 1 time
(1, 13) occurred 1 time
(2, 2) occurred 1 time

(2, 6) occurred 1 time
(2, 7) occurred 1 time
(3, 2) occurred 1 time
(3, 6) occurred 1 time
(3, 6) occurred illegally 1 time
(4, 1) occurred 624 times
(4, 4) occurred 5 times
(4, 7) occurred 5 times
(4, 15) occurred 20 times
(4, 17) occurred 165 times
(4, 18) occurred 565 times
(5, 2) occurred 99 times
(5, 3) occurred 99 times
(5, 4) occurred 99 times
(5, 10) occurred 1 time
(5, 12) occurred 3 times
(5, 13) occurred 3 times
(5, 14) occurred 1 time
(5, 15) occurred 4 times
(5, 16) occurred 4 times
(5, 17) occurred 1 time
(5, 18) occurred 1 time
(5, 22) occurred 95 times
(5, 23) occurred 2 times
(5, 27) occurred 93 times
(5, 28) occurred 93 times
(5, 29) occurred 93 times
(5, 30) occurred 95 times
(5, 34) occurred 1 time

13.1.3 Output Harvard Graphics

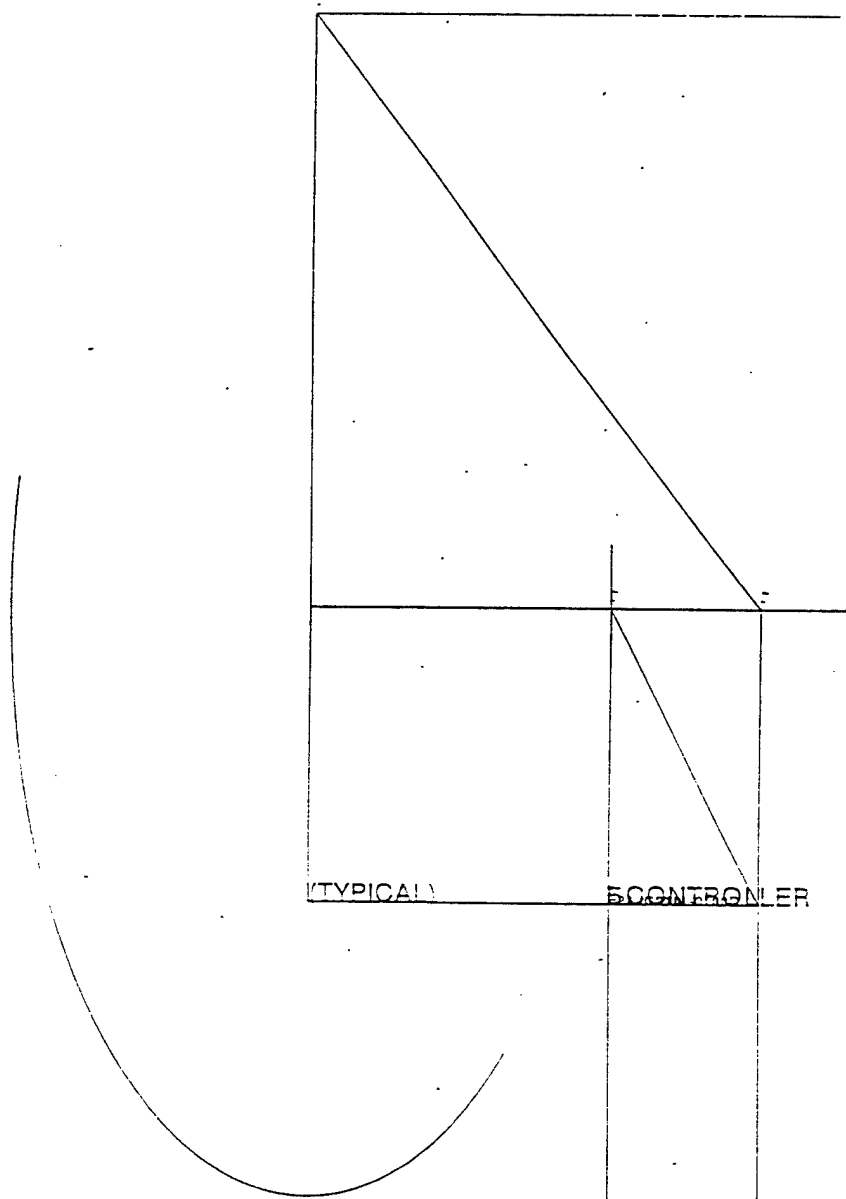

13.1.4 Output cgm2draw/IslandDraw

