



CALS TEST NETWORK

CTN Test Report 93-020



A User's Guide To MIL-M-28001B Graphics Attributes

16 July 1993

FORM 8-73

Prepared For
Air Force CALS Program Office
Det 2 HQ ESC/ENC
Wright-Patterson AFB OH 45431-1601

19960826 114

DISTRIBUTION STATEMENT A

Approved for public release;
Distribution Unlimited

CTN Report 93-020
16 July 1993

A USER'S GUIDE TO MIL-M-28001B
GRAPHIC ATTRIBUTES

16 July 1993

Prepared by:

Navy Test Bed, CALS Test Network
Carderock Division
Naval Surface Warfare Center
Bethesda, MD 20084-5000

NSWC Contacts:

Mary McCarthy
Patricia Beech

TABLE OF CONTENTS

SECTION	PAGE NUMBER
1. INTRODUCTION	1
1.1 GLOSSARY	1
1.2 FOSI GRAPHIC ENVIRONMENT	2
1.2.1 DEFAULT CHARACTERISTIC VALUES	3
2. GRAPHICS	5
2.1 REQUIRED ATTRIBUTE	6
2.1.1 BOARDNO	6
2.2 OPTIONAL (IMPLIED) ATTRIBUTES	6
2.2.1 REPROWID & REPRODEP	7
2.2.2 LLCORDRA & RUCORDRA	8
2.2.3 HSCALE & VSCALE	10
2.2.4 SCALEFIT	11
2.2.5 HPLACE & VPLACE	12
2.2.6 COORDST & COORDEND	14
2.2.7 ROTATION	16
2.2.8 GRAPHSTY	1
3. CONCLUSION	18
Appendix A - TABLE I. Element and attribute set descriptions	19

1. INTRODUCTION

This is a guide to the use of the attributes for the "graphic" element provided as part of the baseline tag set in MIL-M-28001. The "graphic" element and its attributes are to be used in mark-up of documents whose DTD is in conformance with MIL-M-28001. The data dictionary of the "graphic" tag can be found in MIL-M-28001B, Appendix A, pages 109-111. For the reader's convenience, a copy of this data dictionary for the "graphic" tag can be found in Appendix A of this report.

For more detailed information concerning the "graphic" attributes, see Appendix A Section 30.5.5, Appendix B Section 40.2, and Appendix B Section 60.14.1 of MIL-M-28001B.

1.1 GLOSSARY

Definitions of terms used in this guide are provided below:

A. SOURCE GRAPHIC

A source graphic is a graphic file that can be retrieved using the name provided by the "boardno" attribute. This source graphic can be cropped, scaled, and positioned within a reproduction area.

B. REPRODUCTION AREA

A reproduction area is a "window" in which a graphic will be placed. Specifications can be provided (via graphic attributes) for the positioning of the graphic within the reproduction area.

C. SIZE/DISTANCE

This value is used to express measurement. The syntax for describing a size/distance value is "number" followed by the "unit." For instance, "6pt" means 6 points. Numbers can be positive or negative. The numbers can also express precision in tenths or hundredths with the use of decimal points. For instance, "6.4pt" means 6 and 4/10ths of a point.

Each unit is expressed as a two-letter abbreviation ("pi" for picas, "pt" for points, "in" for inches, "mm" for millimeters, "cm" for centimeters, and "em" for em space). Combinations of units are allowed, but must be completely specified. For example, "5pi 3pt" is the

correct syntax for specifying 5 picas and 3 points.

D. INTEGER

An integer is a whole number that is either positive, zero, or negative. An integer may be used to specify a percentage.

E. FOSI

FOSI is an acronym for "Formatting Output Specification Instance." A FOSI contains a set of characteristics and values chosen from the Output Specification in MIL-M-28001 to represent formatting requirements for every element (and attributes if applicable) in the document's DTD, and for every context in which the element has a unique formatting requirement. It should be noted that in order for a graphic to be processed in accordance to the specifications provided by the graphic attributes, the FOSI must define the appropriate formatting characteristics and values for all of the "graphic" attributes.

F. IMPLIED ATTRIBUTE

An attribute with a value (as defined in the DTD) of "#IMPLIED" requires that either the value be provided in the instance or be provided by the application. In the case of cropping, scaling, and positioning a source graphic into a reproduction area based on values of the graphic attributes, IMPLIED attribute values that are not provided in an instance must be provided by the FOSI. The FOSI provides these attribute values through a "default" Graphic Environment. This default set of characteristic values allows the author to leave out attribute values that are supplied in the FOSI.

G. WORLD COORDINATES

The world coordinate system is used to describe the two-dimensional space in which the graphic is defined and placed. The point of origin is the lower left corner of the graphic and has the coordinates (0,0). The upper right corner has the coordinates (10000,10000).

1.2 FOSI GRAPHIC ENVIRONMENT

In order to accommodate the requirement for uniform graphic

styles and to ease the burden of having the author specify all graphic attribute values, a FOSI can provide different sets of graphic characteristic values which can be accessible by the "graphsty" ID. However, every FOSI must define a default Graphic Environment. This default set of characteristic values allows the author to leave out attribute values that are supplied in the FOSI and does not require the "graphsty" attribute to be specified.

For the examples in this user's guide, the graphic characteristic values specified below will be used as the default Graphic Environment.

```
<grphdesc>
<graphenv
  graphenvid="default">
<graphchars>
<repro
  repropwid="2.5in"
  reprodep="2in">
<sizing
  hscale="0"
  vscale="0"
  scalefit="yes"
  llcordra="0,0"
  urcordra="10000,10000">
<placemnt
  hplace="center"
  vrplace="middle"
  coordst="0,0"
  coordend="10000,10000"
  rotation="no">
```

1.2.1 DEFAULT CHARACTERISTIC VALUES

The default attribute values provided by the "default" FOSI Graphic Environment are provided below.

- A. REPROWID & REPRODEP: Default values are 2.5 inches width and 2 inches depth. Default values should be set up to satisfy the majority of graphics being placed in a document, if possible.
- B. LLCORDRA & RUCORDRA: Default values should indicate that entire graphic be scaled into the reproduction area.
- C. HSCALE & VSCALE: Default values should specify no

horizontal or vertical scaling.

- D. SCALEFIT: Default value should be "yes". However, if values for "hscale" & "vscale" are provided in an instance, they will take precedence over "scalefit".
- E. HPLACE & VPLACE: Default value of "hplace" should be "center"; "vplace" should be "middle". However, this is appropriate only if the reproduction area is larger than the size of the source graphic AND "scalefit" is not specified.
- F. COORDST & COORDEND: Default values should indicate that the entire reproduction area is used.
- G. ROTATION: Default value should indicate no rotation.

As is always the case where an author specifies attribute values that affect formatting, values supplied in an instance override the FOSI. This allows authors to make an exception where necessary, and also frees them from having to specify many attributes when they are already provided in the FOSI.

2. GRAPHICS

A graphic can be either stored as vector (MIL-D-28000 or MIL-D-28003) or raster (MIL-R-28002) data and is used as the source for an illustration in a document. The graphic below will be used as the source graphic for all examples in this user's guide. This graphic is 4.477 inches wide and 3.39 inches high. It is being displayed in a reproduction area which is 4.5 inches wide and 3.5 inches high. The graphic file should be stored on the processing system and accessible by the "boardno" attribute. For the examples in this user's guide, the source graphic is accessible using the "boardno" name "wire".

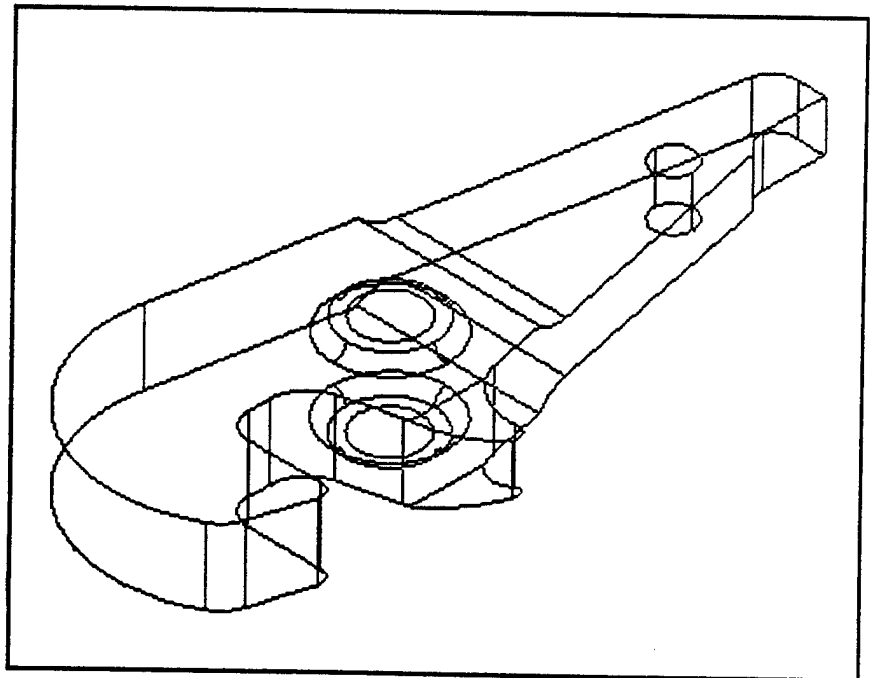

2.1 REQUIRED ATTRIBUTE

2.1.1 BOARDNO

The "boardno" attribute is a required attribute. To incorporate the source graphic used in this user's guide, the SGML tagging is:

```
<graphic boardno="wire">.
```

The purpose of this attribute is for entering the unique graphic identifier, and it acts as a pointer to reference an external file containing the source graphic. The declared value is ENTITY. Therefore, at the beginning of the SGML tagged document in the DOCTYPE statement, there must be an ENTITY defining the "boardno" name. For example:

```
<!ENTITY wire SYSTEM "hook.g4" NDATA fax>
```

where "wire" is the "boardno" attribute value and "hook.g4" is the filename containing the graphic. "NDATA" is non-SGML data containing codes outside the set declared to be valid SGML characters for the document. "fax" is the MIL-M-28001B required notation for raster data.

2.2 OPTIONAL (IMPLIED) ATTRIBUTES

The following is an overview of all the optional graphic attributes. The "reprowid" and "reprodep" attributes specify a reproduction area in which to place the graphic (See Section 2.2.1). The "llcordra" and "rucordra" attributes provide coordinates to identify a portion of the source graphic to be used (See Section 2.2.2). The "hscale" and "vscale" attributes allow the horizontal and vertical scaling of a graphic (See Section 2.2.3). The "scalefit" attribute can be used to automatically scale a graphic to fit a reproduction area (See Section 2.2.4). The "hplace" and "vplace" attributes can be used to indicate a general placement of a graphic within a reproduction area (See Section 2.2.5). The "coordst" and "coordend" attributes can be used to indicate an exact placement of a graphic within a reproduction area through use of coordinates (See Section 2.2.6). The "rotation" attribute can be used to specify the rotation of a graphic when being placed in the reproduction area (See Section 2.2.7). Finally, the "graphsty" attribute can be

used to access values for any or all of these attributes. These default values must be defined in the FOSI (See Section 2.2.8) and accessible by the "graphsty" ID. If no "graphsty" ID is provided for a "graphic", the FOSI uses the "default" values.

2.2.1 REPROWID & REPRODEP

REPROWID is used to specify the desired reproduction area width (size/distance). REPRODEP is used to specify the desired reproduction area depth (size/distance). If specifications are not provided for either attribute, the values specified in a "macrograph" tag should be used. If there is no "macrograph" tag or if there were no values specified in the "macrograph" tag, the FOSI provides the values.

Example:

```
<graphic boardno="wire" reprovwid="4.5in"  
reprodep="3.5in">
```

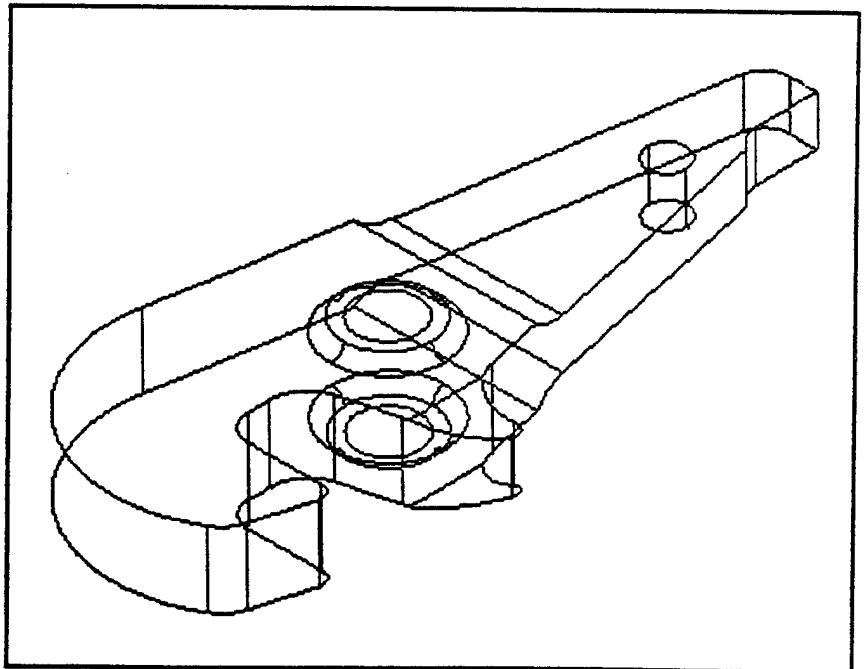

2.2.1a IMPLIED VALUES OF REMAINING ATTRIBUTES: The attribute

values that have not been specified take on the default values as specified in the FOSI. Default LLCORDRA & RUCORDRA specify that the entire graphic be used. Default HSCALE & VSCALE specify no scaling of the graphic. Default SCALEFIT specifies the graphic be scaled to fit the reproduction area. Default HPLACE & VPLACE specifies that "hplace" be "center"; "vplace" be "middle". Note that this is not appropriate since the graphic is being scaled to fit the reproduction area. Default COORDST & COORDEND specifies that the entire reproduction area be used. Default ROTATION specifies "no" rotation.

2.2.2 LLCORDRA & RUCORDRA

LLCORDRA is used to specify the left lower coordinate pair of the portion of a graphic to be placed in the reproduction area. The coordinates are separated by a comma. RUCORDRA is used to specify the right upper coordinate pair of the portion of a graphic to be placed in the reproduction area. The coordinates are separated by a comma. These attributes allow the ability to designate a particular portion of the graphic to be used for an illustration and employs "world coordinates."

The syntax for the llcordra attribute (left lower) is "integer,integer". The first integer is the starting position of the graphic window along the horizontal axis. The second integer is the starting position of the graphic window along the vertical axis. For instance, a LLCORDRA value of "0,0" means that the graphic window starts at the lower left point of the graphic.

The syntax for the rucordra attribute (right upper) is "integer,integer". The first integer is the ending position of the graphic window along the horizontal axis. The second integer is the ending position of the graphic window along the vertical axis. For instance, a RUCORDRA value of "10000,10000" means that the graphic window ends at the upper right point of the graphic.

Example:

```
<graphic boardno="wire" llcordra="0,0"  
rucordra="10000, 10000" reprowid="2.5in"  
reprodep="2in">
```

LLCORDRA value of "0,0" and RUCORDRA value of "10000,10000" specifies the entire graphic be used for the illustration.

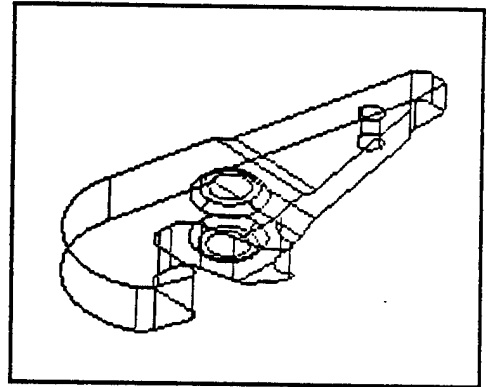

Example:

```
<graphic boardno="wire" llcordra="5000, 5000"  
rucordra="10000, 10000" reprowid="2.5in"  
reprodep="2in">
```

LLCORDRA value of "5000,5000" and RUCORDRA value of "10000,10000" specifies the upper right quadrant of the graphic be used for the illustration.

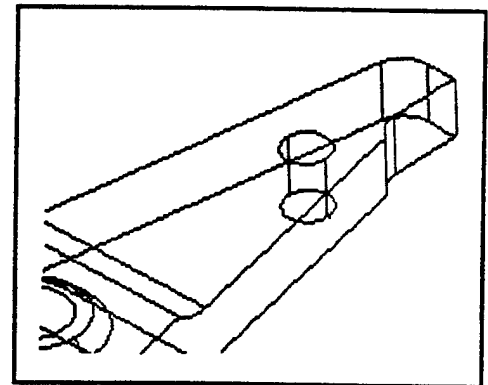

2.2.2a IMPLIED VALUES OF REMAINING ATTRIBUTES: The attribute

values that have not been specified take on the default values as specified in the FOSI. Default HSCALE & VSCALE provide no specific scaling of the graphic. Default SCALEFIT specifies the graphic be scaled to fit the reproduction area. Default HPLACE & VPLACE specifies that "hplace" be "center"; "vplace" be "middle". Note that this is not appropriate since the graphic is being scaled to fit the reproduction-area. Default COORDST & COORDEND specifies that the entire reproduction area be used. Default ROTATION specifies "no" rotation.

2.2.3 HSCALE & VSCALE

The hscale and vscale properties can be changed to scale the graphic to whatever size desired (either larger or smaller than the original). The scaling values are expressed in the form of percentages.

Examples:

```
<graphic boardno="wire" hscale="100"  
vscale="100" repropwid="5in" repropdep="4in">
```

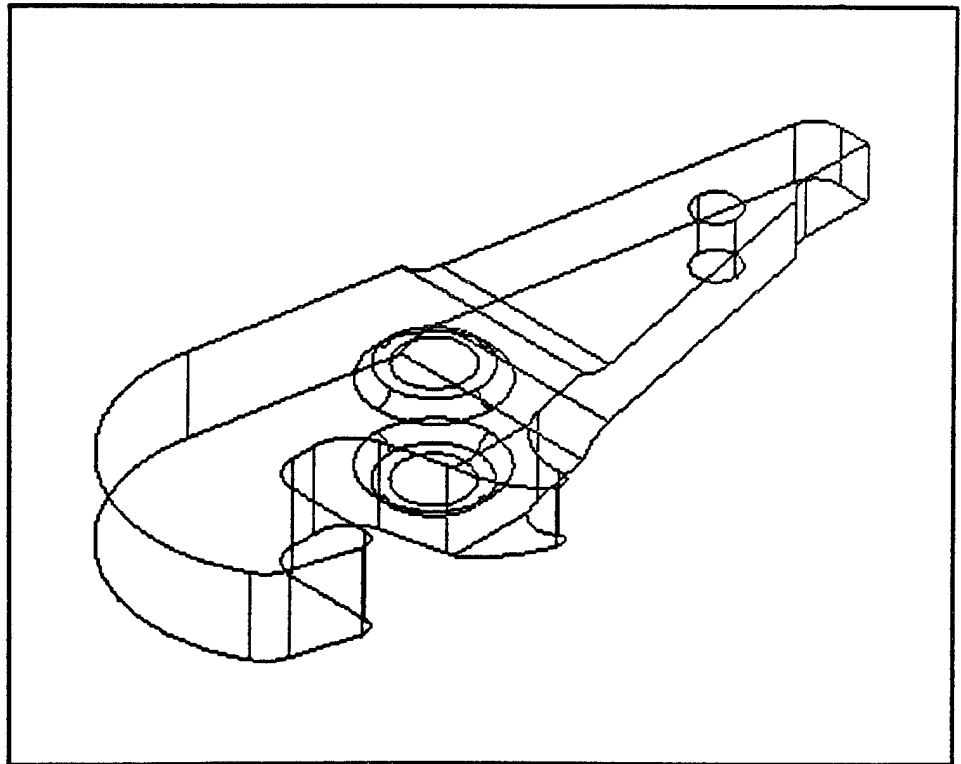

```
<graphic boardno="wire" hscale="50"  
vscale="50" reprojid="2.5in" reprodep="2in">
```

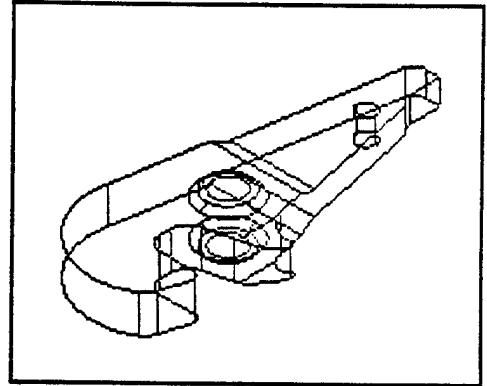

```
<graphic boardno="wire" hscale="25" vscale="25"  
reprojid="1.25in" reprodep="1.25in">
```

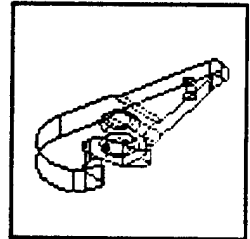

- 2.2.3a IMPLIED VALUES OF REMAINING ATTRIBUTES: The attribute values that have not been specified take on the default values as specified in the FOSI. Default LLCORDRA & RUCORDRA specify that the entire graphic be used. Default SCALEFIT specifies the graphic be scaled to fit the reproduction area. However, since HSCALE and VSCALE are being specified in the examples, these take precedence over SCALEFIT. Default HPLACE & VPLACE specifies that "hplace" be "center"; "vplace" be "middle". Default COORDST & COORDEND specifies that the entire reproduction area be used. Default ROTATION specifies "no" rotation.

2.2.4 SCALEFIT

This attribute allows the graphic to be scaled as needed to fit the size of the reproduction area. The factor for scaling is the same in both directions. If the scaling attributes (hscale and vscale) have values other than "0", these take precedence over the scalefit attribute.

The declared value is %yesorno; "1" for yes and "0" for no.

Example:

```
<graphic boardno="wire" reprowid="2.5in"  
reprodep="2in" scalefit="1">
```

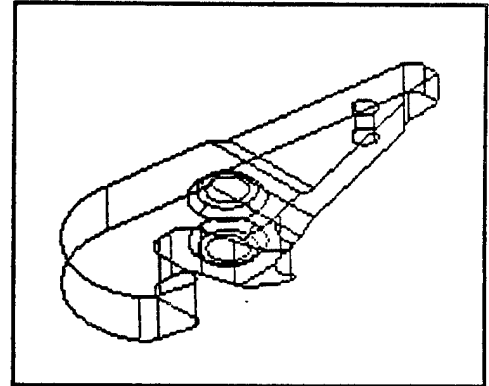

2.2.4a IMPLIED VALUES OF REMAINING ATTRIBUTES: The attribute values that have not been specified take on the default values as specified in the FOSI. Default LLCORDRA & RUCORDRA specify that the entire graphic be used. Default HSCALE & VSCALE provide no specific scaling of the graphic. Default HPLACE & VPLACE specifies that "hplace" be "center"; "vplace" be "middle". Note that this is not appropriate since the graphic is being scaled to fit the reproduction area. Default COORDST & COORDEND specifies that the entire reproduction area be used. Default ROTATION specifies "no" rotation.

2.2.5 HPLACE & VPLACE

The hplace attribute is used to specify a horizontal placement of the graphic within the reproduction area. With the use of the hplace attribute, a graphic can be placed to the left, right or center within the reproduction area.

The vplace attribute is used to specify the vertical placement of the graphics within the reproduction area. With the use of the vplace attribute, the graphics can be placed to the top, bottom, or middle of the reproduction area.

Examples:

```
<graphic boardno="wire" hplace="left"  
reprowid="2.25in" reprodep="2.25in" hscale="50"  
vscale="50">
```

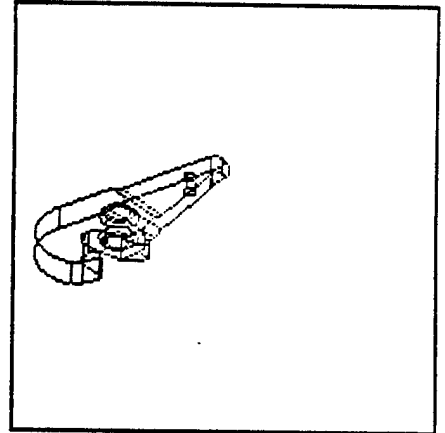

```
<graphic boardno="wire" vplace="top"  
reprowid="2.25in" reprodep="2.25in" hscale="50"  
vscale="50">
```

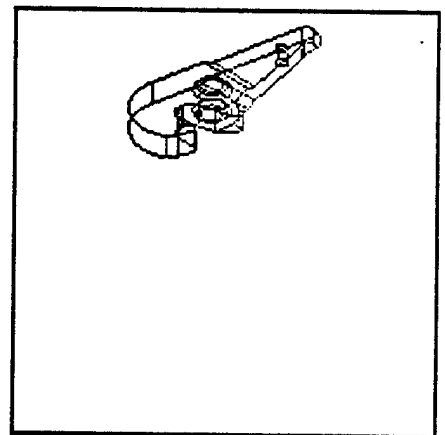

```
<graphic boardno="wire" hplace="right"  
vplace="bottom" reprodid="2.25in"  
reprodep="2.25in" hscale="50" vscale="50">
```

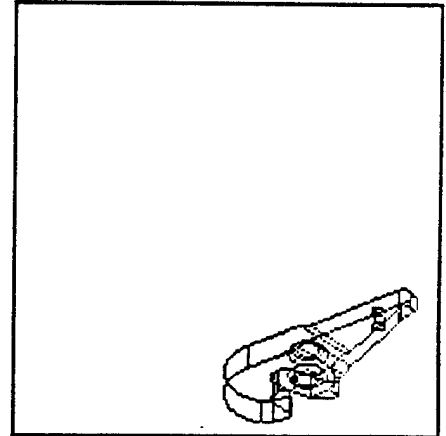

2.2.5a IMPLIED VALUES OF REMAINING ATTRIBUTES: The attribute values that have not been specified take on the default values as specified in the FOSI. Default LLCORDRA & RUCORDRA specify that the entire graphic be used. Default SCALEFIT specifies the graphic be scaled to fit the reproduction area. However, since HSCALE and VSCALE are being specified in the examples, these take precedence over SCALEFIT. Default COORDST & COORDEND specifies that the entire reproduction area be used. Default ROTATION specifies "no" rotation.

2.2.6 COORDST & COORDEND

The coordst attribute provides the left lower coordinate pair which specifies the start position in the reproduction area for placing the graphic. The coordend attribute provides the right upper coordinate pair. This is the end position in the reproduction area for placing the graphic. Both attributes employ the "world coordinates".

The syntax for the coordst attribute (left lower) is "integer, integer". The first integer is the starting position of the reproduction area along the horizontal axis. The second integer is the starting position of the reproduction area along the vertical axis. For instance, a COORDST value of "0,0" means that the lower left corner

of the graphic would be placed to the lower left of the reproduction area.

The syntax for the coordend attribute (right upper) is "integer, integer". The first integer is the ending position of the reproduction area along the horizontal axis. The second integer is the ending position of the reproduction area along the vertical axis. For instance, a COORDEND value of "10000,10000" means that the upper right corner of the graphic would be placed at the upper right point of the reproduction area.

Example:

```
<graphic boardno="wire" coordst="0,0"  
coordend="10000,10000" reprowid="2.25in"  
reprodep="2.25in" hscale="50" vscale="50">
```

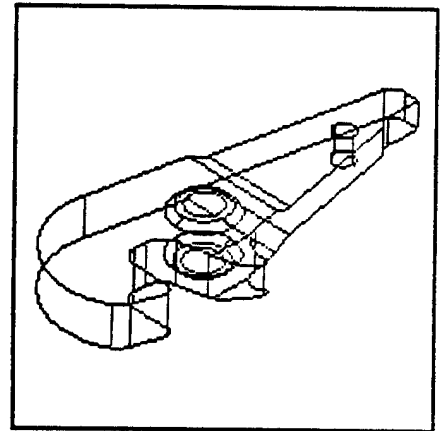

```
<graphic boardno="wire" coordst="5000,5000"  
coordend="10000,10000" hscale="25" vscale="25"  
reprowid="2.25in" reprodep="2.25in">
```

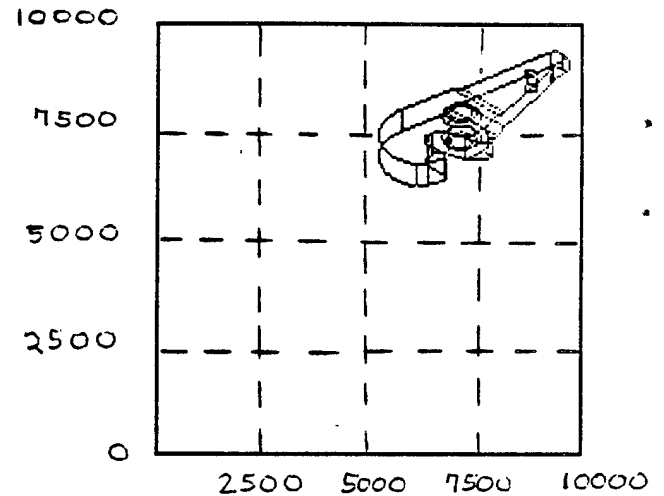

2.2.6a IMPLIED VALUES OF REMAINING ATTRIBUTES: The attribute values that have not been specified take on the default values as specified in the FOSI. Default LLCORDRA & RUCORDRA specify that the entire graphic be used. Default SCALEFIT specifies the graphic be scaled to fit the reproduction area specified by COORDEND and COORDST. However, since HSCALE and VSCALE are being specified in these examples, these take precedence over SCALEFIT. Default ROTATION specifies "no" rotation.

2.2.7 ROTATION

The ROTATION attribute value gives the degree of rotation on the graphics.

Example:

```
<graphic boardno="wire" reprodep="2.25"  
reprowid="2.25" hscale="50" vscale="50"  
rotation="90">
```

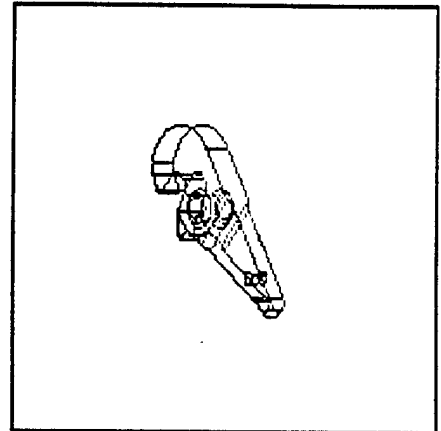

2.2.7a IMPLIED VALUES OF REMAINING ATTRIBUTES: The attribute values that have not been specified take on the default values as specified in the FOSI. Default LLCORDRA & RUCORDRA specify that the entire graphic be used. Default SCALEFIT specifies the graphic be scaled to fit the reproduction area. However, since HSCALE and VSCALE are being specified in the examples, these take precedence over SCALEFIT. Default COORDST & COORDEND specifies that the entire reproduction area be used.

2.2.8 GRAPHSTY

The graphsty attribute is a feature which allows access to Graphic Environments that have been pre-defined in a FOSI. Attribute values are defined in the FOSI and are accessible by the graphsty attribute "ID". In every FOSI there must be one Graphic Environment which has the name "default". This default set of characteristic values allows the author to leave out attribute values that are supplied in the FOSI. If the "graphsty" attribute is not included in an instance, the FOSI assumes that the "default" Graphic Environment is to be used. As is always the case where an author can specify attribute values that affect formatting, the author's values override the FOSI characteristics. This allows for authors to make

exception where necessary, but also frees them from having to specify many attributes when they are already provided in the FOSI.

3. CONCLUSION

The graphic attributes allow users to give specifications for cropping, scaling, and positioning of source graphics in a reproduction area. However, in order to format the graphics correctly, the FOSI requires careful interpretations of the graphic attributes values. The graphic attributes are defined in MIL-M-28001B, part of the Baseline Tag Set, and to be used in DTDs compliant with MIL-M-28001B.

MIL-M-28001B

APPENDIX A

TABLE I. <u>Element and attribute set descriptions</u>		
Element/Attribute	Full Name	Description
<graphic	Graphic	Identifies a graphic. A graphic is stored either as vector (MIL-D-28000 or MIL-D-28003) or raster (MIL-R-28002) data and is used as an illustration in the document.
boardno =x		<p>Required Attribute(s)</p> <p>BOARDNO: Enter unique graphic identifier. Declared Value = ENTITY</p>
graphsty =x		<p>Optional Attribute(s)</p> <p>GRAPHSTY: Characteristic provided to allow for cases where the "grphstyl" ID is to be used. Declared Value = NMTOKEN Default = IMPLIED (NULL implies only one style available).</p>
llcordra =x		<p>LLCORDRA: Left lower coordinate pair of the portion of the graphic to be placed in the portion of the repro area, separated by comma. Declared Value = CDATA Default = IMPLIED (NULL)</p>

MIL-M-28001B

APPENDIX A

TABLE I. <u>Element and attribute set descriptions</u> - Continued.		
Element/Attribute	Full Name	Description
rucordra =x		RUCORDRA: Right upper coordinate pair of the portion of the graphic to be placed in the portion of the repro area, separated by comma. Declared Value = CDATA Default = IMPLIED (NULL)
reprowid =x		REPROWID: Repro area width. Declared Value = NUTOKEN Default = IMPLIED (NULL implies value from <macrograph>, if available, NULL if not)
reprodep =x		REPRODEP: Repro area depth. Declared Value = NUTOKEN Default = IMPLIED (NULL implies value from <macrograph>, if available, NULL if not)
hscale =x		HSCALE: Horizontal scaling. Declared Value = NUTOKEN Default = IMPLIED (NULL)
vscale =x		VSCALE: Vertical scaling. Declared Value = NUTOKEN Default = IMPLIED (NULL)
scalefit = x		SCALEFIT: Characteristic allows the graphic to be scaled as needed to fit the size of the reproduction area. Declared Value = %yesorno; (NUMBER) Default = IMPLIED (NULL)

MIL-M-28001B

APPENDIX A

TABLE I. <u>Element and attribute set descriptions</u> - Continued.		
Element/Attribute	Full Name	Description
hplace =x		HPLACE: Horizontal placement in the available repro area. Declared Value = left, right, center, or none (equivalent to a null value which defaults to implied by the graphstyle). Default = IMPLIED (NULL)
vplace =x		VPLACE: Vertical placement in the available repro area. Declared Value = top, middle, bottom, or non (equivalent to a null value which defaults to implied by the graphstyle). Default = IMPLIED (NULL)
coordst =x		COORDST: Left lower coordinate pair, separated by comma. Start position in repro area for placement of the portion of the graphic specified by llcordra and rucordra. Declared Value = CDATA Default = IMPLIED (NULL)
coordend =x		COORDEND: Right upper coordinate pair, separated by comma, end position in repro area for placement of portion of the graphic. Declared Value = CDATA Default = IMPLIED (NULL)
rotation =x		ROTATION: Degree of rotation of the graphic. Declared Value = NUMBER Default = IMPLIED (NULL)

MIL-M-28001B

APPENDIX A

TABLE I. <u>Element and attribute set descriptions</u> - Continued.		
Element/Attribute	Full Name	Description
%bodyatt =x		%BODYATT;; Any of the attributes in the associated Attribute Set may be used with this element. Default = As appropriate for each attribute in the set.
%secur;>		%SECUR;; Any of the attributes in the associated Attribute Set may be used with this element. Default = As appropriate for each attribute in the set.