



# AFCTN Test Report 94-082

AFCTB-ID  
94-056



**Technical Publication Transfer Using:**

**Mr. Jessie Bailey's**



**Master Thesis Data**

**On Behalf of:**



**Eastern Kentucky University**



**MIL-STD-1840A  
MIL-M-28001B (SGML)  
MIL-R-28002A (Raster)**

**Quick Short Test Report**

**20 May 1994**

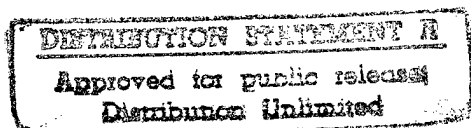

19960822 113



*Prepared for  
Electronic Systems Center  
Air Force CALS Program Office  
HQ ESC/AV-2  
4027 Colonel Glenn Hwy Suite 300  
Dayton OH 45431-1672*

**DTIC QUALITY INSPECTED 3**

# DISCLAIMER NOTICE



**THIS DOCUMENT IS BEST QUALITY AVAILABLE. THE COPY FURNISHED TO DTIC CONTAINED A SIGNIFICANT NUMBER OF PAGES WHICH DO NOT REPRODUCE LEGIBLY.**

**AFCTN Test Report**  
94-082

**AFCTB-ID**  
94-056

---

**Technical Publication Transfer**  
**Using:**  
**Mr. Jessie Bailey's Master Thesis Data**  
**On Behalf Of:**  
**Eastern Kentucky University**

**MIL-STD-1840A**  
**MIL-M-28001B (SGML)**  
**MIL-R-28002A (Raster)**

**Quick Short Test Report**

**20 May 1994**

---

**Prepared By**  
Air Force CALS Test Bed  
Wright-Patterson AFB, OH 45433

**DTIC QUALITY INSPECTED 3**

**AFCTB Contact**  
Gary Lammers  
(513) 427-2295

**AFCTN Contact**  
Mel Lammers  
(513) 427-2295

## DISCLAIMER

This document was prepared as an account of the work sponsored by the Air Force. Neither the United States Government, the Air Force, nor any of their employees makes any warranty, express or implied, or assumes any legal liability or responsibility for the accuracy, completeness, or usefulness of any information, apparatus, product, or process disclosed, nor represents that its use would not infringe on privately owned rights. Reference herein to any specific commercial products, process, or service by trade name, trademark, manufacturer, or otherwise, does not necessarily constitute or imply its endorsement, recommendation, or favoring by the United States Government or the Air Force. The views and opinions of authors expressed herein do not necessarily state or reflect those of the United States Government or the Air Force, and shall not be used for advertising or product endorsement purposes.

Available to the public from the  
National Technical Information Service  
U.S. Department of Commerce  
5285 Port Royal Road  
Springfield, VA 22161

This report and those involved in its preparation do not endorse any product, process, or company stated herein. Use of these means by anyone does not imply certification by the Air Force CALS Test Network (AFCTN).

---

# **Air Force CALS Test Bed**

## ***Notification of Test Results***

**20 May 1994**

This notice documents the results of an Air Force CALS Test Bed (AFCTB) Quick Short Test Report (QSTR) evaluation of data submitted by:

### **Eastern Kentucky University**

Identified as follows:

Title:	<b>Technical Publication Transfer</b>
Program:	<b>Master Thesis</b>
Program Office:	<b>Mr. Jessie Bailey</b>
Contract No.:	<b>N/A</b>
QSTR No.:	<b>AFCTB-ID 94-056</b>

Received on the following media:    Electronic Transfer

The results of the QSTR evaluation are as follows:

MIL-STD-1840A Standard	<b>Pass</b>
MIL-STD-1840A Media Format:	<b>Pass</b>
MIL-D-28000A IGES:	<b>N/A</b>
MIL-M-28001B SGML:	<b>Pass</b>
MIL-R-28002A Raster:	<b>Pass</b>
MIL-D-28003 CGM:	<b>N/A</b>

Formal results with associated disclaimer are documented and available from the AFCTB.

**Air Force CALS Test Bed  
HQ ESC/AV-2P  
4027 Colonel Glenn Highway, Suite 300  
Dayton, OH 45431-1672  
Phone: 513-257-3085      FAX: 513-257-5881**

---

## Contents

1.	Introduction.....	1
1.1.	Background.....	1
1.2.	Purpose.....	2
2.	Test Parameters.....	3
3.	1840A Analysis.....	5
3.1.	External Packaging.....	5
3.2.	Transmission Envelope.....	5
3.2.1.	Tape Formats.....	5
3.2.2.	Declaration and Header Fields.....	5
4.	IGES Analysis.....	5
5.	SGML Analysis.....	6
6.	Raster Analysis.....	7
7.	CGM Analysis.....	8
8.	Conclusions and Recommendations.....	9
9.	Appendix A - Tapetool Report Logs.....	10
9.1.	Tape Catalog.....	10
9.2.	Tape File Set Validation Log.....	11
10.	Appendix B - Detailed SGML Analysis.....	13
10.1.	ArborText Parser Log.....	13
10.2.	Exoterica XGMLNormalizer Parser.....	14
10.3.	Exoterica Validator.....	15
10.4.	Sema Mark-it Log.....	16

10.5. SoftQuad Log.....16

11. Appendix C - Detailed Raster Analysis.....17

    11.1. File D001R007.....17

        11.1.1. Output IGESView.....17

12. Appendix D - Published Document.....18

## 1. Introduction

### 1.1 Background

The Department of Defense (DoD) Air Force Continuous Acquisition and Life-cycle Support (CALs) Test Network (AFCTN) is conducting tests of the military standard for the Automated Interchange of Technical Information, MIL-STD-1840A, and its companion suite of military specifications. The AFCTN is a DoD sponsored confederation of voluntary participants from industry and government managed by the Electronic Systems Center (ESC).

The primary objective of the AFCTN is to evaluate the effectiveness of the CALs standards for technical data interchange and to demonstrate the technical capabilities and operational suitability of those standards. Two general categories of tests are performed to evaluate the standards; formal and informal.

Formal tests are large and comprehensive, which follow a written test plan, require specific authorization from the DoD, and may take months to prepare, execute, and report.

Informal tests are quick and short, used by the AFCTN technical staff, to broaden the testing base. They include representative samples of the many systems and applications used by AFCTN participants. They also allow the AFCTN staff to gain feedback from many industry and government interpretations of the standards, to increase the base of participation in the CALs initiative, and respond to the many requests for help that come from participants. Participants take part voluntarily, benefit by receiving an evaluation of their latest implementation (interpretation) of the standards, interact with the AFCTN technical staff, gain experience using the standards, and develop increased confidence in them. The results of informal tests are reported in Quick Short Test Reports (QSTRs) that briefly summarize the standard(s) tested, the hardware and software used, the nature of the test, and the results.

## 1.2 Purpose

The purpose of the informal test, reported in this QSTR, was to analyze Mr. Jessie Bailey's, of Eastern Kentucky University, interpretation and use of the CALS standards in transferring technical publication data. Mr. Bailey used his CALS Technical Data Interchange System to produce data, in accordance with the standards, and delivered it to the AFCTN technical staff via an electronic transfer.

The document set was presented as part of a Master Thesis for Mr. Bailey.

## 2. Test Parameters

Test Plan: AFCTB 94-056

Date of Evaluation: 20 May 1994

Evaluator: George Elwood  
Air Force CALS Test Bed  
DET 2 HQ ESC/AV-2P  
4027 Colonel Glenn Hwy  
Suite 300  
Dayton OH 45431-1672

Data Originator: Jessie Bailey  
Eastern Kentucky University  
PO Box 485  
Richmond KY 40476-0485

Data Description: Technical Manual Test  
1 Document Declaration file  
1 Document Type Definition (DTD)  
1 Text/Standard Generalized Markup Language (SGML) file  
8 Raster files

Data Source System:

1840

**HARDWARE**

Unknown

**SOFTWARE**

AFCTN Tapetool 1.2.10

Text/SGML

**HARDWARE**

PC 386

**SOFTWARE**

InContext's InContext v1.0

Raster

**HARDWARE**

PC 386

**SOFTWARE**

Inset Systems HiJaak Pro

---

Evaluation Tools Used:

MIL-STD-1840A (TAPE)

PC 486/50

AFCTN Tapetool v1.2.10 DOS

MIL-M-28001 (SGML)

HP 735

ArborText ADEPT v5.0

PC 486/50

Exoterica XGMLNormalizer v1.2e3.2

Exoterica Validator v2.2 ex1

SoftQuad Author/Editor v2.1

McAfee & McAdam Sema Mark-it v2.3

Public Domain sgmls

InContext InContext v1.0

MIL-R-28002 (Raster)

HP 735

InterCAP X-Change v7.82

ArborText g42tiff

SGI Indigo2

IGES Data Analysis (IDA) CALSView

SUN SparcStation 2

Carberry CADLeaf Plus v3.1

AFCTN validg4

AFCTN xrastb.sun4

IDA IGESView v3.0

PC 486

IDA IGESView Windows

Inset Systems HiJaak Pro

Expert Graphics RxHighlight v1.0

Standards

Tested:

MIL-STD-1840A

MIL-M-28001B

MIL-R-28002A

### **3. 1840A Analysis**

#### **3.1 External Packaging**

The file set arrived at the Air Force CALS Test Bed (AFCTB) via an electronic transfer to the internet server. No physical media was exchanged or evaluated.

#### **3.2 Transmission Envelope**

The electronic transfer file set received by the AFCTB contained MIL-STD-1840A files. The file set was named per the standard conventions.

##### **3.2.1 Tape Formats**

No tape was submitted for evaluation.

##### **3.2.2 Declaration and Header Fields**

No errors were reported in the Document Declaration file and data file headers. This portion of the file set meets the CALS MIL-STD-1840A requirements.

### **4. IGES Analysis**

No Initial Graphics Exchange Specification (IGES) files were included in this evaluation.

## 5. SGML Analysis

The file set contained one text file and one DTD. The submitted DTD was the baseline 38784C which is known to have errors.

The AFCTB has several parsers available for evaluating submitted DTD and text files. These tools are not used to generate a pass/fail but to report how commercially available software can handle the files. These products are used in the development of technical publications and are good indicators of usability. The use of these products is not an endorsement nor an indication of CALS capability. All operations were performed using the default settings unless specified in the report.

The text and DTD files were tested using the Exoterica *XGMLNormalizer* parser. This application reported three warnings, all relating to mixed content models in the DTD.

The text and DTD files were evaluated using the Exoterica *Validator exl* parser. This application reported four warnings. Three of which were mixed content models and the fourth was a defined and not used entity.

The text and DTD files were evaluated using McAfee & McAdam's *Sema Mark-it v2.3* parser. No errors were reported in either file.

The text and DTD files were evaluated using InContext's *InContext v1.0*. No errors were reported in either file.

The text and DTD files were evaluated using SoftQuad *Author/Editor*. This program reported a ambiguous content model in the element graphic. This is a bug in the software that has been corrected in the most current release.

The text file was imported into ArborText's *Adept* software. During the parsing procedure, six warnings were reported. All six warnings related to mixed content models. The graphics files were converted and the document was published using a generic Format Output Specification Instance (FOSI), available within the AFCTB. A copy of the document is included in Appendix D of this report.

---

According to Chris Moffett of ArborText, Inc., "This (or These) warning(s) may be due to a syntax error in the DTD."

The SGML files meet the CALS MIL-M-28001B specification.

## 6. Raster Analysis

The transfer set contained eight Raster files. All files were evaluated using the AFCTN *validg4* utility. This program reported all eight files meet the CALS MIL-R-28002A specification.

The files were read into the AFCTN *xrastb.sun4* viewing utility. No problems were noted.

The AFCTB has several tools for viewing Raster files. These tools are not used to generate a pass/fail but to report how commercially available software can handle the files. Many of these products are used in the development of technical publications and are good indicators of usability. The use of these products is not an endorsement nor an indication of CALS capability. All operations were performed using the default settings.

The files were converted using ArborText's *g42tiff* utility without a reported error. The resulting files were read into Island Graphics' *IslandPaint*, displayed and printed when the document was published.

The Raster files were read into Carberry's *CADLeaf* software without a reported error. The images were displayed with no noted errors.

The files were read and displayed using IDA's *CALSVIEW* without a reported error.

The files were read and displayed using IDA's *IGESVIEW* and *IGESVIEW for Windows* without a reported error.

The files were read and displayed using Inset Systems' *HiJaak for Windows* without a reported error.

The files were read and displayed using InterCAP's *X-Change* without a reported error.

---

The Raster files were imported and displayed using Expert Graphics' *RxHighlight* without a reported error.

The Raster files meet the CALS MIL-R-28002A specification.

## 7. CGM Analysis

No Computer Graphics Metafile (CGM) files were included in this evaluation.

## 8. Conclusions and Recommendations

The electronic data set submitted by Mr. Jessie Bailey of Eastern Kentucky University was correct.

The DTD was an older version that had known errors. Most of the parsers used by the AFCTB found and reported mixed content model warnings. The document was published using a generic FOSI available within the AFCTB. The SGML files meet the CALS MIL-M-28001B specification.

The Raster files meet the CALS MIL-R-28002A specification.

The document set submitted by Mr. Bailey meets the CALS MIL-STD-1840A requirements.

## 9. Appendix A - Tapetool Report Logs

### 9.1 Tape Catalog

CALS Test Network Catalog Evaluation - Version 1.2; Release 10 (O)

Standards referenced:

- MIL-STD-1840A (1987) - Automated Interchange of Technical Information
- ANSI X3.27 (1987) - File Structure and labeling of Magnetic Tapes  
for Information Interchange
- ANSI X3.4 (1986) - Coded Character Sets - 7 Bit ASCII

Thu May 19 16:27:52 1994

MIL-STD-1840A File Catalog

File Set Directory: C:\TF\SET016

Page: 1

File Name	File Type	Record Format/ Length	Block Length/Total	Selected/ Extracted
D001	Document Declaration	D/00256	02048/000000	Extracted
D001G001	DTD	D/00256	02048/000000	Extracted
D001R002	Raster	F/00128	02048/000000	Extracted
D001R003	Raster	F/00128	02048/000000	Extracted
D001R004	Raster	F/00128	02048/000000	Extracted
D001R005	Raster	F/00128	02048/000000	Extracted
D001R006	Raster	F/00128	02048/000000	Extracted
D001R007	Raster	F/00128	02048/000000	Extracted
D001R008	Raster	F/00128	02048/000000	Extracted
D001R009	Raster	F/00128	02048/000000	Extracted
D001T010	Text	D/00256	02048/000000	Extracted

Catalog Process terminated normally.

## 9.2 Tape File Set Validation Log

CALS Test Network File Set Evaluation - Version 1.2; Release 10 (O)

Standards referenced:

MIL-STD-1840A (1987) - Automated Interchange of Technical Information

Thu May 19 16:27:53 1994

MIL-STD-1840A File Set Evaluation Log

File Set: SET016

Found file: D001

Extracting Document Declaration Header Records...

Evaluating Document Declaration Header Records...

srcsys: Jesse A. Bailey

srcdocid: TO 35E4-197-3

srcrelid: NONE

chglvl: ORIGINAL

dteisu: 19940511

dstsys: AIR FORCE CALS TEST BED

dstdocid: TO 35E4-197-3

dstrelid: NONE

dtetrn: 19940511

dlvacc: NONE

filcnt: G1,R8,T1

ttlcls: UNCLASSIFIED

doccls: UNCLASSIFIED

doctyp: Technical Publication

docttl: NONE

Found file: D001G001

Extracting DTD Header Records...

Evaluating DTD Header Records...

srcdocid: TO 35E4-197-3

dstdocid: TO 35E4-197-3

notes: NONE

Saving DTD Header File: D001G001.HDR

Saving DTD Data File: D001G001.DTD

Found file: D001R002

Extracting Raster Header Records...

Evaluating Raster Header Records...

srcdocid: TO 35E4-197-3  
dstdocid: TO 35E4-197-3  
txtfilid: W  
figid: NONE  
srcgph: EXPNDREM  
doccls: UNCLASS  
rtype: 1  
rorient: 000,270  
rpelcnt: 000837,001197  
rdensty: 0300  
notes: NONE

Saving Raster Header File: D001R002.HDR  
Saving Raster Data File: D001R002.GR4

<<<<< PART OF LOG FILE REMOVED HERE >>>>>

Found file: D001T010  
Extracting Text Header Records...  
Evaluating Text Header Records...

srcdocid: TO 35E4-197-3  
dstdocid: TO 35E4-197-3  
txtfilid: W  
doccls: UNCLASSIFIED  
notes: NONE

Saving Text Header File: D001T010.HDR  
Saving Text Data File: D001T010.TXT

Evaluating numbering scheme...  
No errors were encountered during numbering scheme evaluation.  
Numbering scheme evaluation complete.

Checking file count...  
No errors were encountered during file count verification.  
File Count verification complete.

No errors were encountered in Document D001.

No errors were encountered in this File Set.

MIL-STD-1840A File Set Evaluation Complete.

---

## 10. Appendix B - Detailed SGML Analysis

### 10.1 ArborText Parser Log

(Parser Warning:

While parsing file 9456-da/9456/9456.dtd:

Potential problem in the mixed content model of element CALLOUT.

At some location within the model, the entry of separators between tags will not always be permitted. It is often possible to fix this problem by writing the #PCDATA model token in a repeatable OR group.

(err:768 line:2097 pos:33709)

Dtgen Parser Warning:

While parsing file 9456-da/9456/9456.dtd:

Potential problem in the mixed content model of element ITEM.

At some location within the model, the entry of separators between tags will not always be permitted. It is often possible to fix this problem by writing the #PCDATA model token in a repeatable OR group.

(err:768 line:2097 pos:33709)

Dtgen Parser Warning:

While parsing file 9456-da/9456/9456.dtd:

Potential problem in the mixed content model of element TERM.

At some location within the model, the entry of separators between tags will not always be permitted. It is often possible to fix this problem by writing the #PCDATA model token in a repeatable OR group.

(err:768 line:2097 pos:33709)

Dtgen Parser Warning:

While parsing file 9456-da/9456/9456.dtd:

Potential problem in the mixed content model of element CALLOUT.

At some location within the model, the entry of separators between tags will not always be permitted. It is often possible to fix this problem by writing the #PCDATA model token in a repeatable OR group.

(err:768 line:2097 pos:33643)

Dtgen Parser Warning:

While parsing file 9456-da/9456/9456.dtd:

Potential problem in the mixed content model of element ITEM.

At some location within the model, the entry of separators between tags will not always be permitted. It is often possible to fix this problem by writing the #PCDATA model token in a repeatable OR group.

(err:768 line:2097 pos:33643)

Dtgen Parser Warning:  
While parsing file 9456-da/9456/9456.dtd:  
Potential problem in the mixed content model of element TERM.  
At some location within the model, the entry of separators between tags  
will not always be permitted. It is often possible to fix this problem  
by writing the #PCDATA model token in a repeatable OR group.  
(err:768 line:2097 pos:33643)

## 10.2 Exoterica XGMLNormalizer Parser

C:\XGML\XGMLNORM.EXE --  
Warning on line 466 in file 9456.dtd:  
An element with mixed content does not permit data characters  
everywhere.  
Spaces and line breaks in element 'CALLOUT' may be treated as data  
characters, forcing insertion of markup.

C:\XGML\XGMLNORM.EXE --  
Warning on line 716 in file 9456.dtd:  
An element with mixed content does not permit data characters  
everywhere.  
Spaces and line breaks in element 'ITEM' may be treated as data  
characters, forcing insertion of markup.

C:\XGML\XGMLNORM.EXE --  
Warning on line 967 in file 9456.dtd:  
An element with mixed content does not permit data characters  
everywhere.  
Spaces and line breaks in element 'TERM' may be treated as data  
characters, forcing insertion of markup.

---

## 10.3 Exoterica Validator

```
<!-- **Warning** in "\xgml\9456.dtd", line 466:
  An element with mixed content should permit data characters ("#PCDATA")
  everywhere.
  The element being declared is "CALLOUT".
  <!ELEMENT callout      - - (#PCDATA | graphic) >
                                     /\
-->
<!-- **Warning** in "\xgml\9456.dtd", line 716:
  An element with mixed content should permit data characters ("#PCDATA")
  everywhere.
  The element being declared is "ITEM".
  <!ELEMENT item        - o (%text;, (%list;)*, footnote*) >
                                     /\
-->
<!-- **Warning** in "\xgml\9456.dtd", line 967:
  An element with mixed content should permit data characters ("#PCDATA")
  everywhere.
  The element being declared is "TERM".
  <!ELEMENT term        - o (%termele;) >
                                     /\
-->
<!-- **Warning** in "\xgml\9456.dtd", line 1049:
  An element is not allowed in the document instance because it does not
  appear in any accessible content model or it is completely excluded.
  The element is "SHORTTITLE".
-->
<!-- Capacity points/limits:
  TOTALCAP =99247/200000
  ENTCAP   =12960/200000
  ENTCHCAP =11069/70000
  ELEMCAP  =4672/70000
  GRPCAP   =24672/70000
  EXGRPCAP =576/70000
  EXNMCAP  =1056/70000
  ATTCAP   =28128/200000
  ATTCHCAP =708/70000
  AVGRPCAP =14880/70000
  NOTCAP   =192/70000
  NOTCHCAP =334/70000
  IDCAP    =0/70000
  IDREFCAP =0/70000
  MAPCAP   =0/70000
  LKSETCAP =0/70000
  LKNMCAP  =0/70000
-->
<!-- 4 warnings reported. -->
```

## 10.4 Sema Mark-it Log

No reported errors.

## 10.5 SoftQuad Log

Error in Document Type Declaration at offset 24725 of the input stream, on line 792 of the document: Ambiguous content model. An instance of element GRAPHIC could simultaneously match two or more tokens in the content model.

## 11. Appendix C - Detailed Raster Analysis

### 11.1 File D001R007

#### 11.1.1 Output IGESView

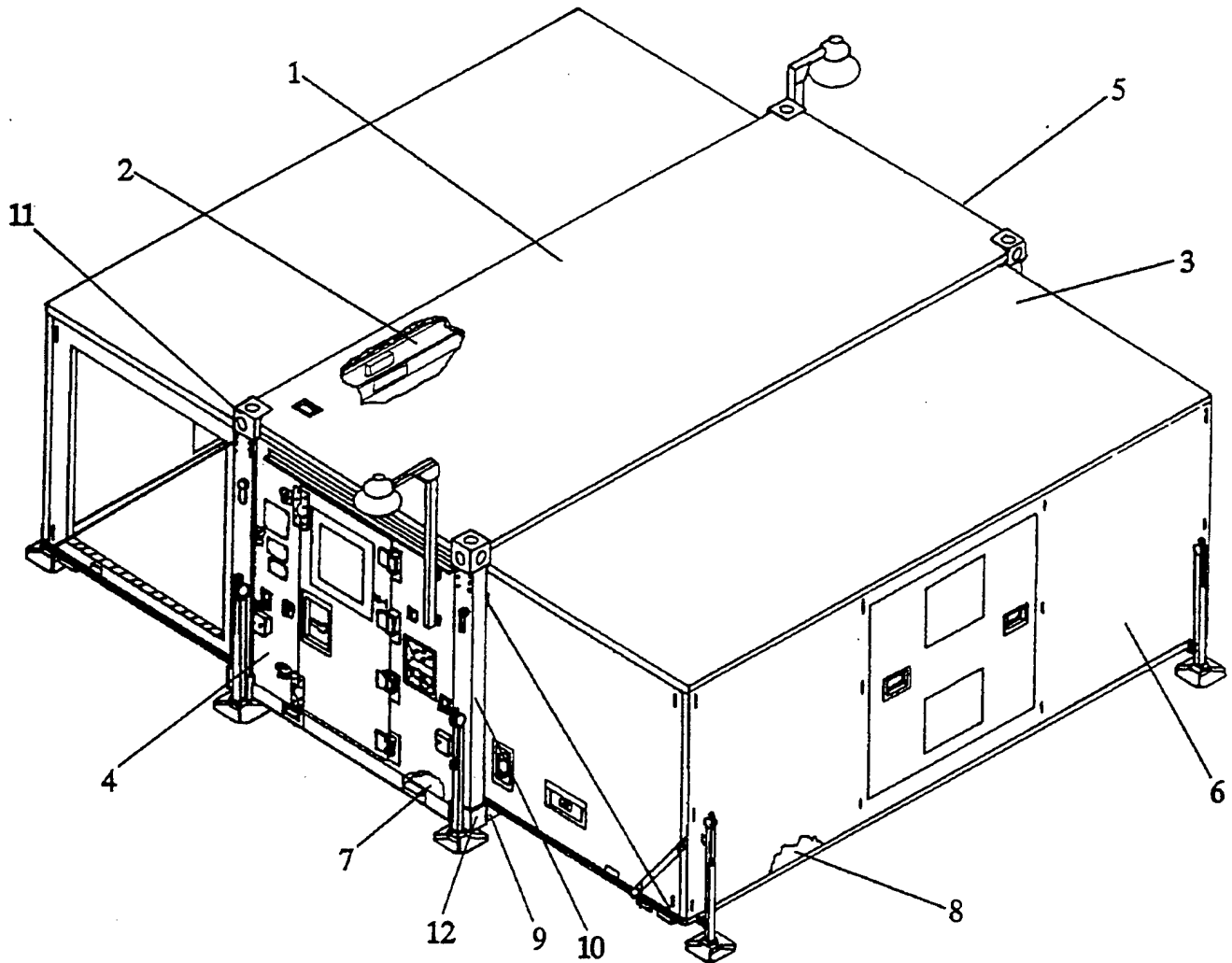

## **12. Appendix D - Published Document**

See following nineteen pages.

---

PRELIMINARY

TECHNICAL MANUAL  
OVERHAUL INSTRUCTIONS

**SHELTER, EXPANDABLE SHU-40/E** Comply with distribution statement and destroy by any method that will prevent disclosure of the contents or reconstruction of the document. Distribution authorized to US Government agencies and their contractors (Administrative or Operational Use) (31 January 1993). Other requests for this document shall be referred to WR-ALC/LZDTA, Robins AFB GA 31098-1622. Questions concerning technical content should be directed to WR-ALC/LYLCN, Robins AFB, GA, 31098-1638.

Published under authority of the Secretary of the Air Force.

## TABLE OF CONTENTS

Chapter	Page	Chapter	Page
TABLE OF CONTENTS . . . . .	i	<b>2 SPECIAL TOOLS AND TEST EQUIPMENT</b>	<b>2-1</b>
FOREWORD . . . . .	ii	2.1 SCOPE . . . . .	2-1
1 GENERAL . . . . .	???-ii	2.2 SPECIAL TOOLS AND TEST EQUIPMENT	2-1
2 SCOPE OF MANUAL . . . . .	???-ii	2.3 LIST OF CONSUMABLES . . . . .	2-1
2.1 Chapter1 - General Information . . . . .	0-ii	<b>3 DISASSEMBLY . . . . .</b>	<b>3-1</b>
2.2 Chapter 2 - Special Tools and Test Equipment	0-ii	3.1 HINGED SIDEWALL . . . . .	3-1
2.3 Chapter 3 - Disassembly . . . . .	0-ii	3.2 FIXED FLOOR . . . . .	3-1
2.4 Chapter 4 - Cleaning . . . . .	0-ii	<b>4 CLEANING . . . . .</b>	<b>4-1</b>
2.5 Chapter 5 - Inspection, Repair, and Replace- ment . . . . .	0-ii	4.1 DETERGENT CLEANING . . . . .	4-1
2.6 Chapter 6 - Assembly . . . . .	0-ii	4.2 SOLVENT CLEANING . . . . .	4-1
3 APPLICABLE SPECIFICATIONS AND STANDARDS . . . . .	???-ii	4.3 CORROSION REMOVAL . . . . .	4-1
4 APPLICABLE TECHNICAL ORDERS	???-ii	<b>5 INSPECTION, REPAIR, AND REPLACEMENT</b>	<b>5-1</b>
<b>1 GENERAL INFORMATION . . . . .</b>	<b>1-1</b>	5.1 REPAIR . . . . .	5-1
1.1 DESCRIPTION . . . . .	1-1	5.1.1 Panel Skin Damage . . . . .	5-1
1.1.1 Purpose of Expandable Shelter, SHU-40/E	1-1	5.2 REPLACEMENT . . . . .	5-1
1.1.2 Location and Description of Major Compo- nents . . . . .	1-1	5.2.1 Potted Inserts . . . . .	5-1
1.1.3 Leading Particulars . . . . .	1-3	5.2.2 Nonpotted Inserts . . . . .	5-3
1.1.4 Shelter Orientation . . . . .	1-4		

## FOREWORD

### 1 GENERAL

This manual contains overhaul instructions for the Shelter, Expandable, SHU-40/E. The shelter is used primarily in command and control operations but may be used in a variety of other applications. The basic shelter is manufactured by Brunswick (05699) and modified to the SHU-40/E Expandable Shelter configuration by Serv-Air, Inc. (7S976).

### 2 SCOPE OF MANUAL

The manual consists of six chapters as follows:

2.1 Chapter 1 - General Information This chapter contains a paragraph describing purpose of the shelter, location and description of components to be repaired or replaced, and a list of the shelter's leading particulars.

2.2 Chapter 2 - Special Tools and Test Equipment This chapter contains a list of special tools, test equipment, and consumables required to maintain the shelter.

2.3 Chapter 3 - Disassembly This chapter contains procedures for removing depot-level maintenance items.

2.4 Chapter 4 - Cleaning This chapter contains special cleaning procedures.

2.5 Chapter 5 - Inspection, Repair, and Replacement This chapter covers inspection, repair, and replacement of depot-level maintenance items.

2.6 Chapter 6 - Assembly This chapter contains procedures for installing depot-level maintenance items.

### 3 APPLICABLE SPECIFICATIONS AND STANDARDS

The specifications and standards used in the preparation of this manual are as follows: MIL-C-53072, Chemical Agent Resistant Coating (CARC), System Application Procedures and Quality Control Inspection MIL-M-38789A, Manuals, Technical: Overhaul Instructions and Overhaul Instructions with Illustrated Parts Breakdown MIL-M-38784C, Manuals, Technical: General Style and Format Requirements

### 4 APPLICABLE TECHNICAL ORDERS

TO 00-25-234; General Shop Practice Requirements for the Repair, Maintenance, and Test of Electrical Equipment, TO 1-1-691; Corrosion Prevention and Control for Aerospace Equipment, TO 35C1-2-1185-1; Operator, Unit, and Direct Support Maintenance Manual for Distribution Illumination Systems, Electrical (DISE) and Power Distribution Illumination Systems, Electrical (PDISE) Consisting of Electrical Feeder System M200, M200 A/P (6150-01-208-9755), (6150-01-308-5672), Electrical Feeder System M100, M100 A/P (6150-01-208-9754), (6150-01-308-5671), Electrical Distribution System M40, M40 A/P (6150-01-208-9753), (6150-01-307-9446), Electrical Distribution System M60, M60 A/P (6150-01-208-9752), (6150-01-307-9445), Electrical Utility Assembly M46 (6150-01-208-9751) TO 35C1-2-1185-4 Unit and Direct Support Maintenance Repair Parts and Special Tools List for Distribution Illumination Systems, Electrical (DISE) and Power Distribution Illumination Systems, Electrical (PDISE), consisting of Electrical Feeder System M200, M200 A/P (6150-01-208-9755), (6150-01-308-5672), Electrical Feeder System M100, M100 A/P (6150-01-208-9754), (6150-01-308-5671), Electrical Distribution System M40, M40 A/P (6150-01-208-9753), (6150-01-307-9446), Electrical Distribution System M60, M60 A/P (6150-01-208-9752), (6150-01-208-9752), (6150-01-307-9445), Electrical Utility Assembly M46 (6150-01-208-9751) TO 35E4-197-1 Operation and Maintenance Instructions, Shelter, Expandable, SHU-40/E TO 35E4-200-1 Organizational and Maintenance Instructions with IPB for Shelter Lifting and Rolling System 1350.6, 5 TO 35E5-8-1 Operator's, Unit, and Direct Support Maintenance Manual for Complexing Kit Passageway, Type I Forest Green, NSN: 8340-01-277-0620; Tan, NSN: 8340-01-277-061, and Type II, Class A, Forest Green, NSN 8340-01-260-7452; Tan, NSN: 8340-01-261-6650 TO 35E5-8-4 Unit and Direct Support Maintenance Repair Parts and Special Tools List for Complexing Kit Passageway, Type I, Forest Green, NSN: 8340-01-277-0620; Tan, NSN: 8340-01-277-061-9; Type II, Class A, Forest Green, NSN: 8340-01-260-7452; Tan, NSN: 8340-01-261-6650; Type II, Class B, Forest Green, NSN: (unassigned); Tan, NSN: (unassigned) TO 35E9-163-1 Operation and Maintenance Instructions with IPB for Air Conditioner A/E 32C-39 54000 BTU/HR PN 12090-601/602/603/604/605 TO 36A4-24 -1 Operator's, Organizational, Direct Support, and General Support Maintenance Manual (Including Repair Parts and Special Tools List) for Dolly Set, Lift, Transportable Shelter M689 Composed of Dolly, Trailer, Front: M690 and Dolly, Trailer, Rear M691 TO 36A4-34-1 Operator's, Unit, Direct Support, and General Support Maintenance Manual (Including Repair Parts and Special Tools List) Dolly Set, Lift, Transportable Shelter, 7 $\frac{1}{2}$  -Ton, M1022



## CHAPTER 1

### GENERAL INFORMATION

#### 1.1 DESCRIPTION

1.1.1 Purpose of Expandable Shelter, SHU-40/E The SHU-40/E Shelter is a self-contained utility shelter. The SHU-40/E Shelter has the capability to be used in many different applications and can be moved to various locations. However, the primary use of the SHU-40/E Shelter is command and control operations. The SHU-40/E Shelter is a member of

the family of standard rigid-wall International Organization for Standardization (ISO) shelters used by the Air Force. The SHU-40/E Shelter will be referred to as the shelter throughout the remainder of the manual.

1.1.2 Location and Description of Major Components The following list gives a breakdown of major component locations and their descriptions. See figure 1-1.

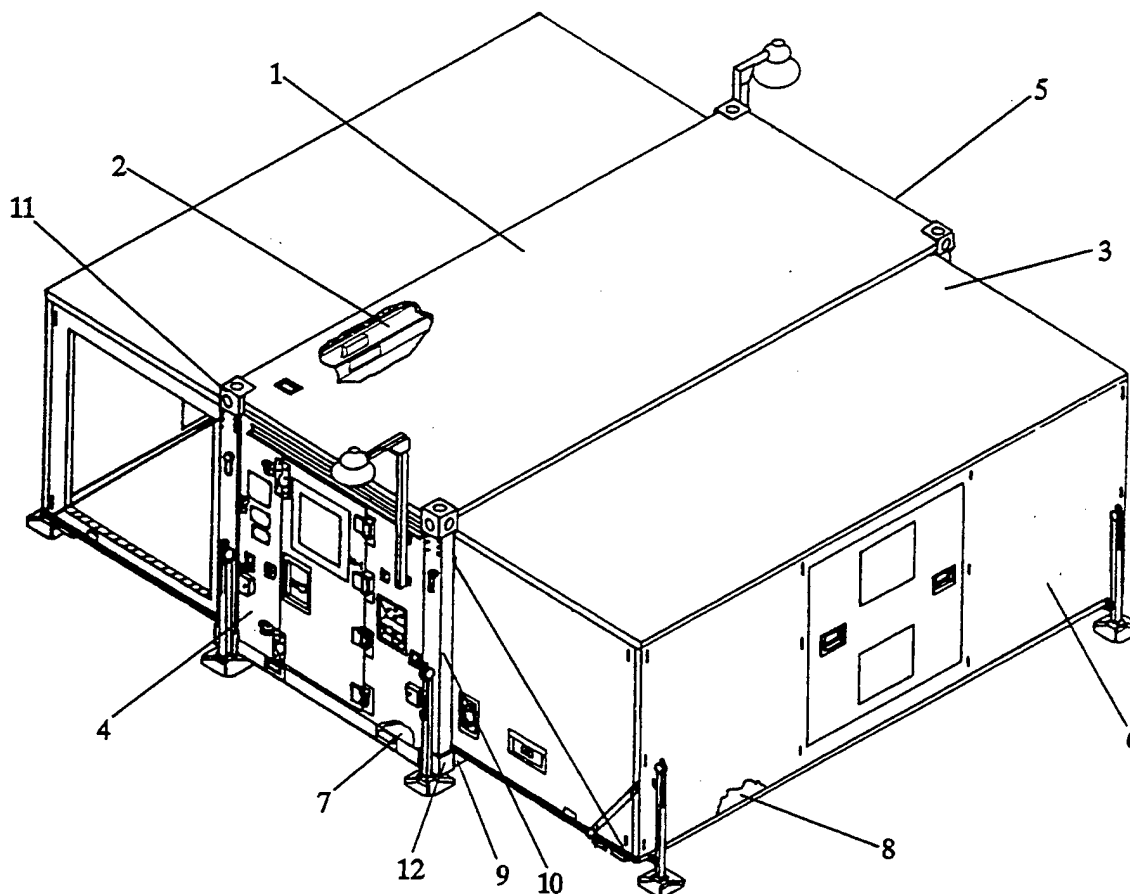

Figure 1-1 Major Components (Sheet 1 of 2)

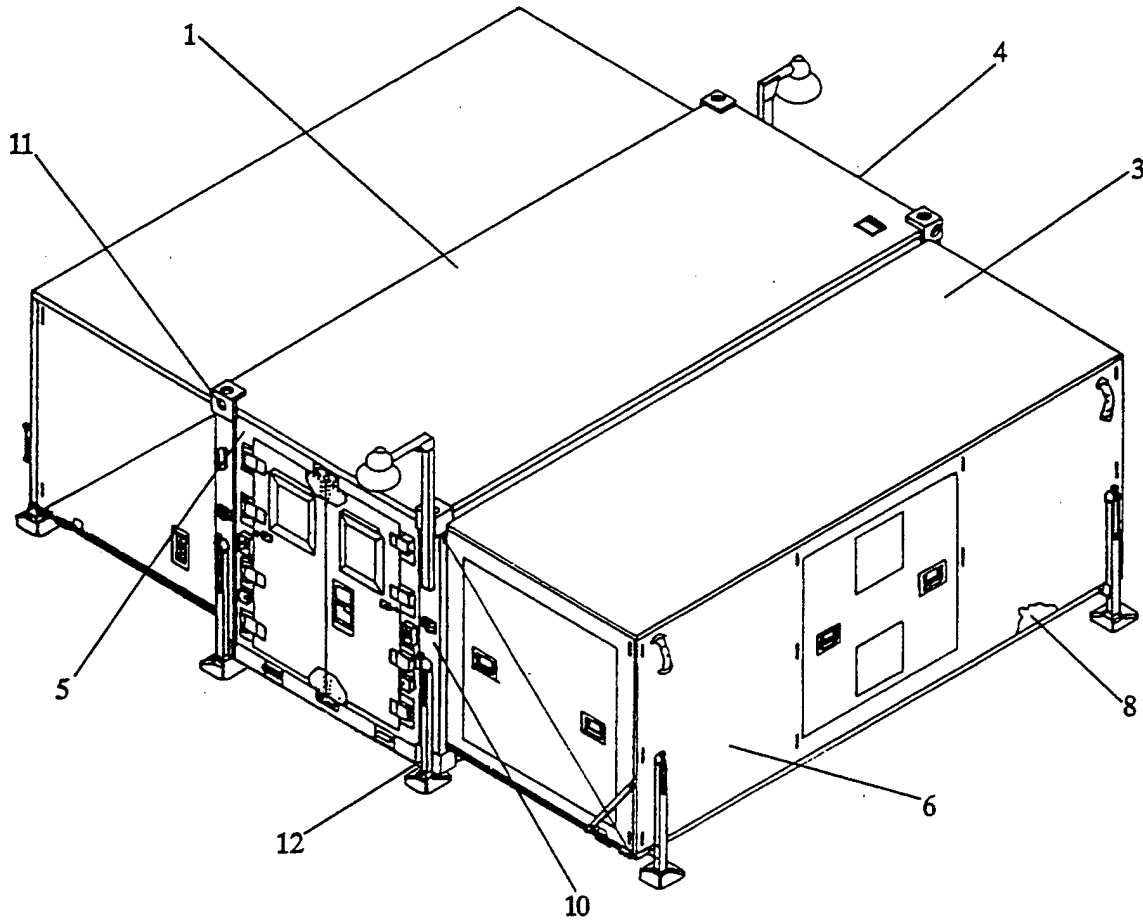

Figure 1-2 Major Components (Sheet 2 of 2)

- a. Fixed Roof (1). Provides roof for fixed section of shelter.
- b. Roof Beam (2). Provides structural support and serves as a raceway for shelter wiring.
- c. Hinged Roof Panel (3). Hinged to fixed roof (1). The hinged roof panel (3) swings up to provide roof for expanded section of the shelter.
- d. Personnel Fixed Endwall (4). Provides personnel door endwall for fixed section of shelter.
- e. Cargo Fixed Endwall (5). Provides cargo door endwall for fixed section of shelter.
- f. Hinged Sidewalls (6). Hinged to hinged floor panels (8). The hinged sidewall swings upward to form a sidewall.
- g. Fixed Floor Panel (7). Provides floor for fixed section of shelter.
- h. Hinged Floor Panel (8). Hinged to fixed floor panel (7). Provides additional floor space when shelter is expanded.
- i. Base Frame (9). Provides basic shelter structural support.

- j. Corner Post (10). Provides shelter structural support.
- k. Upper ISO Fitting (11). Provides upper contact point for lifting and moving of shelter.
1. Lower ISO Fitting (12). Provides lower contact point for lifting and moving of shelter.
- 1.1.3 Leading Particulars Refer to table 1-1.

Input Power Characteristics	120/208 VAC, 60 Hz, 3 phase, 5 wire								
Mobility Characteristics	Forklift - built in forklift provisions Transporters - equipped with mobilizer and ISO fittings (upper and lower) for transportation Model no. M832 - maximum capacity 10,000 lb (4546 kg) Model no. M1022 - maximum capacity 15,000 lb (6804 kg) Model no. A/E 32U-14 - maximum capacity 15,000 lb (6804 kg)								
Dimensions and Weight	Dimensions: Exterior dimensions (stowed shelter) Width - 8 ft, 5-1/2 in (2.58 m) Height - 8 ft (2.44 m) Length - 19 ft, 10-1/2 in (6.06 m) Exterior dimensions (expanded shelter) Width - 21 ft, 9 in (6.63 m) Height - 8 ft (2.44 m) Length - 19 ft, 10-1/2 in (6.06 m) Interior dimensions Minimum clear height - 80.29 in (2.04 m) Minimum clear width (stowed mode) - 77.78 in (1.98 m) Minimum clear length (stowed) - 229 in (5.82 m) Expanded shelter usable floor space - 400 sq ft (37.2 sq m) Weight: Less payload - 7730 lb(3506 kg) With payload (max) - 15,000 lb (6809 kg)								
Composition Material	Aluminum								
Environmental Limits	Temperature -65 deg. F to +125 deg. F(-53.9 to +51.7 deg. C)								
Emergency Fluorescent Light Power Supply	Illumination: Operates one 2-ft or 4-ft fluorescent lamp for 90 minutes Provides 80% of initial emergency output at end of 90-minute discharge Construction: Dual-voltage input capability (120 or 277 volts) Battery: Requires 24-hour battery recharge after 90 minute discharge Expected Life <table border="0"> <thead> <tr> <th>Ambient Temperature</th> <th>Life</th> </tr> </thead> <tbody> <tr> <td>100 deg F</td> <td>5 yrs</td> </tr> <tr> <td>77 deg F</td> <td>10 yrs</td> </tr> <tr> <td>30 deg F</td> <td>15 yrs</td> </tr> </tbody> </table>	Ambient Temperature	Life	100 deg F	5 yrs	77 deg F	10 yrs	30 deg F	15 yrs
Ambient Temperature	Life								
100 deg F	5 yrs								
77 deg F	10 yrs								
30 deg F	15 yrs								

## Figure 1-3 Leading Particulars

1.1.4 Shelter Orientation Shelter personnel door is point of reference for determining right and left. When personnel are standing outside, facing personnel door, all items located to right of shelter midpoint are right oriented. All items located

to left of shelter midpoint are left oriented. Midpoint of shelter is not a marked line, but is an imaginary, dividing line running parallel to the longest side of fixed roof.

## CHAPTER 2

### SPECIAL TOOLS AND TEST EQUIPMENT

#### 2.1 SCOPE

This section lists special tools, test equipment, and consumable items. The tools and test equipment are used for depot level maintenance of the shelter. Equivalent items or tools may be used.

#### 2.2 SPECIAL TOOLS AND TEST EQUIPMENT

Refer to table 2-1 for the special tools and test equipment list.

#### 2.3 LIST OF CONSUMABLES

Refer to table 2-2 for a list of consumables.



## CHAPTER 3

### DISASSEMBLY

#### 3.1 HINGED SIDEWALL

- a. Prepare a work area (21 ft by 9 ft) for the hinged sidewall (1, see figure 3-6). Support surface should be level and nonmarring.
- b. Perform shelter expansion procedure.
- c.

**WARNING**

Do not remove hinged sidewall closeout panel before removing hinged sidewall. Failure to observe warning could result in injury to personnel and/or damage to shelter equipment.

Remove rivets, disengaging threshold (2) from hinged floor (3).

- d. Attach clamps (4) to hinged sidewall (1).
- e. Attach lifting device to lifting beam (5). Attach lifting beam (5) to clamps (4).
- f. Lift beam (5), applying enough tension on the hinged sidewall (1) to allow for removal of the hinge pins (6) that connect the hinged sidewall (1) to the hinged floor (3).
- g. Place two additional scissor jacks under hinged floor, positioning scissor jacks an equal distance from the center of the hinged floor.
- h. Raise scissor jacks until top plate of scissor jack contacts hinged floor.
- i.

#### NOTE

It may be necessary to work hinged sidewalls back and forth to aid in hinged pin removal.

Using a 1/8-in punch and a hammer, drive hinge pins (6) away from the center of the hinged sidewall (1); remove hinge pins (6).

- j. Remove support braces (7); remove hinged sidewall (1) from hinged floor (3) and place on previously prepared work area.

- k. Remove rivets (8), disengaging hinges (9) from hinged sidewall (1).

#### 3.2 FIXED FLOOR

- a. Remove hinged sidewalls and floors from shelter.
- b.

**CAUTION**

A block of wood or thick cardboard should be placed between the shelter and the metal ratcheting device used to tighten the strap. If caution is not observed, damage to shelter panel skin could occur.

Place aircraft cargo tie-down straps (1, see figure 3-7) around the shelter, securing hinged roof and endwalls in place. Tighten strap (1).

- c. Remove bolts (2), lockwashers (3), and washers (4), disengaging the fixed floor (5) from the corner posts, personnel-end fixed endwalls, and the cargo-end fixed endwall.
- d.

**CAUTION**

Lifting beam and lifting device must be capable of lifting 8000 lb (3628.74 kg). If not observed, damage to shelter could occur.

Leave straps, installed during step b, in place until shelter body is reinstalled to fixed floor. If not observed, damage to shelter could occur.

Attach bridle sling (6) to lifting beam (7). Attach hooks (8) of bridle sling (6) to upper ISO fittings (9); lift shelter body away from fixed floor (5) and place on four pieces of dunnage; leave straps installed.



## CHAPTER 4

### CLEANING

#### 4.1 DETERGENT CLEANING

##### **WARNING**

Do not mix detergent cleaner (MIL-C-87936) with a solvent. Mixing these two items will create a fire hazard.

##### **CAUTION**

Do not apply MIL-C-87936 cleaner to electrical wiring or transparent plastic panels. Damage to wiring insulation and plastic panels may occur.

##### **NOTE**

The effectiveness of MIL-C-87936 cleaning compound is directly related to the proper cleaner-to-water mixing ratio and strict adherence to cleaning solution application procedures. Without the addition of water, the emulsifiers and cleaning agents contained in this material will not perform properly. The composition of this cleaning compound is such that the cleaning ability is reduced when used full strength (as received) or when mixed with other cleaning materials.

All areas should be first cleaned with a detergent (MIL-C-87936) before cleaning with a solvent. Heavily soiled areas may need to be cleaned repeatedly, reducing the need for solvent cleaning. Refer to TO 1-1-691 for detergent cleaning procedures.

#### 4.2 SOLVENT CLEANING

##### **WARNING**

Wear ANSI Z87.1, Type II goggles, protective wet weather clothing, solvent resistant gloves, boots, and head covering when using P-D-680. Failure to observe warning may result in injury to personnel.

Do not use P-D-680 in areas of oxygen storage and transfer systems. P-D-680 mixed with oxygen will cause an explosion and/or fire.

Use in a properly, well ventilated area to prevent prolonged breathing of vapors.

Do not mix with other cleaning compounds. Fire may result.

##### **CAUTION**

Do not allow P-D-680 to mix with other cleaning compounds. Damage to unprotected, nonmetallic materials may occur.

Utilize solvent (P-D-680) cleaning only when detergent cleaning is not adequate to remove foreign matter. Refer to TO 1-1-691 for solvent cleaning procedures.

#### 4.3 CORROSION REMOVAL

Refer to TO 1-1-691 for corrosion removal procedures. Re-paint in accordance with MIL-C-53072 and table 4-1. Refer to drawing 13226E7354 (Ft. Belvoir) for camouflage pattern.



## CHAPTER 5

### INSPECTION, REPAIR, AND REPLACEMENT

#### 5.1 REPAIR

5.1.1 Panel Skin Damage Refer to TO 35E4-197-1 for procedures.

#### 5.2 REPLACEMENT

5.2.1 Potted Inserts Use the following procedures to replace potted inserts (constructed of two parts, sleeve and expander). Table 5-1 lists the original insert part number and the spool-type insert replacement. A spool-type insert must be used in place of the original insert because of the increase in hole size created by removing the original insert.

- a. Select a drill bit to correspond with insert thread size. Refer to the following table.
- b.

**WARNING**

Wear safety goggles to protect eyes from flying chips.

Drill head flange from insert. See figure 5-1.

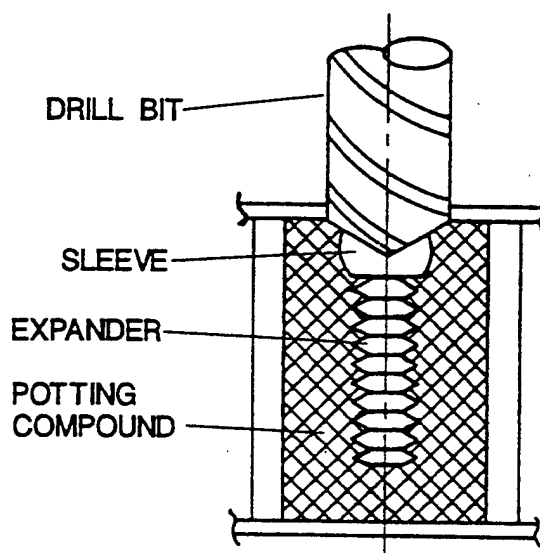

Figure 5-4 Figure 5-1. Drilling Head Flange

c.



Do not drill a hole larger in diameter than the drill bit selected in step a. Do not drill into opposite skin. If caution is not adhered to, damage to shelter will occur.

Drill small holes around insert body in potting compound to approximate depth of insert. See figure 5-2.

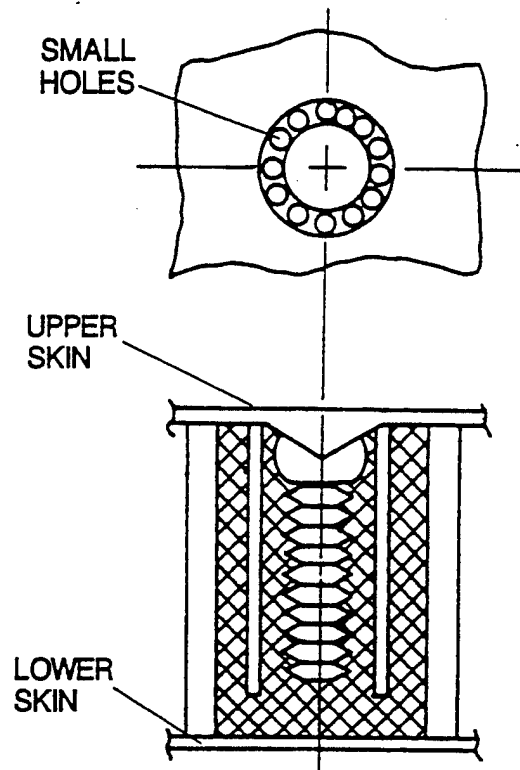

- d. Install bolt of corresponding thread size into insert.
- e. Use wrench to break insert loose; remove insert from hole.
- f.



Do not drill through opposite skin. If caution is not adhered to, damage to shelter will occur.

Using a drill bit slightly larger than replacement flange diameter (refer to table 5-1), drill a hole approximately 1/16 inch deeper than replacement insert length.

- g. Remove honeycomb from drilled hole until voided area is 1 inch in diameter with 0.125 to 0.250 inch of honeycomb material remaining at bottom of voided area.
- h.



Wear ANSI Z87.1, Type II goggles, protective wet weather clothing, solvent resistant gloves, boots, and head covering when using P-D-680. Failure to observe warning may result in injury to personnel.

Do not use P-D-680 in areas of oxygen storage and transfer systems. P-D-680 mixed with oxygen will cause an explosion and/or fire.

Use in a properly ventilated area to prevent prolonged breathing of vapors.

Do not mix with other cleaning compounds. Fire may result.

#### NOTE

After cleaning, handle insert with clean, white gloves (part no. JJ-G-001396).

Clean replacement insert with solvent (part no. P-D-680). Refer to paragraph 4-2 for solvent cleaning procedures.

- i. Mask skin area around hole with masking tape (part no. 2501IN). See figure 5-3.

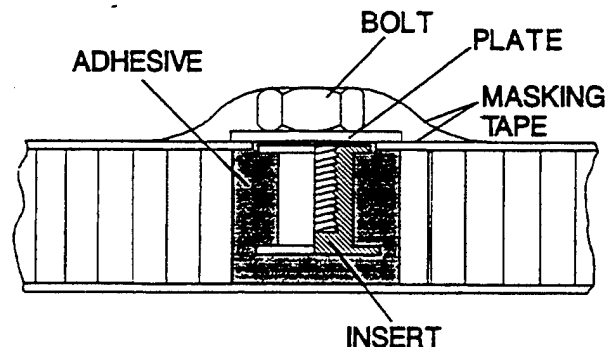

- j. Prepare aluminum plate approximately  $2 \times 2 \times 0.25$  inches with a center hole diameter equal to replacement insert thread size.
- k. Install bolt with same thread size through plate and into insert. Hand-tighten bolt against plate.
- l. Mix sufficient amount of adhesive (part no. FE6026) to fill voided area.
- m. Fill voided area with adhesive, ensuring there are no air pockets.
- n. Using a threading motion, force preassembled insert into filled hole until plate is flush against skin.
- o. Clean excess adhesive from work area. Apply masking tape over bolt, maintaining alignment during curing cycle.

- p. Cure inserts for 72 hours at 75 F.

5.2.2 Nonpotted Inserts Perform the following procedures to replace nonpotted inserts. Nonpotted inserts will not be found in honeycomb material.

- a. Select a drill bit to correspond with insert thread size.
- b.

**WARNING**

Wear safety goggles to protect eyes from flying chips.

Drill head flange from insert. See figure 5-4.

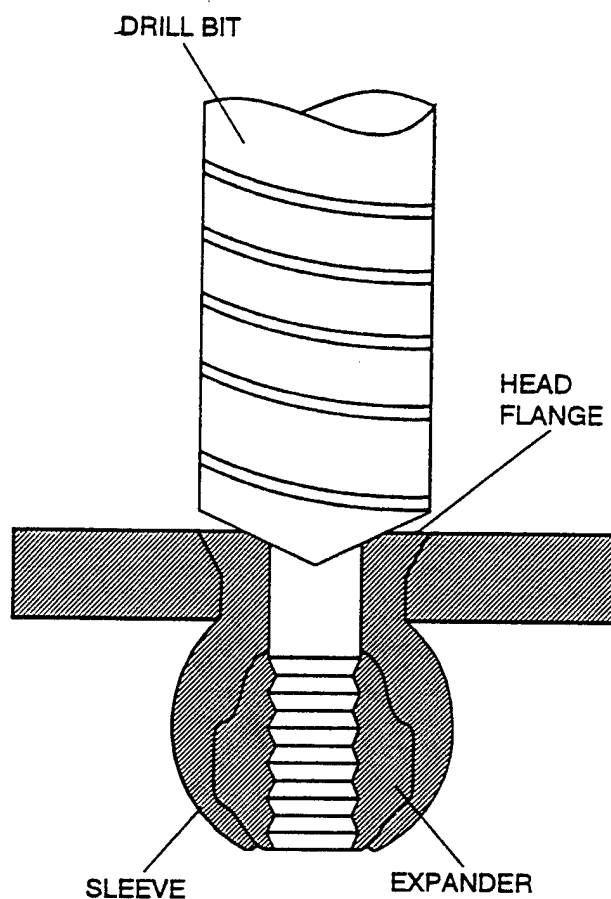

c. Using a punch and hammer, remove any remaining portion of the insert from the hole.

d. Insert appropriate mandrel, part of BH245-25 assembly, (see figure 5-5) through replacement sleeve.

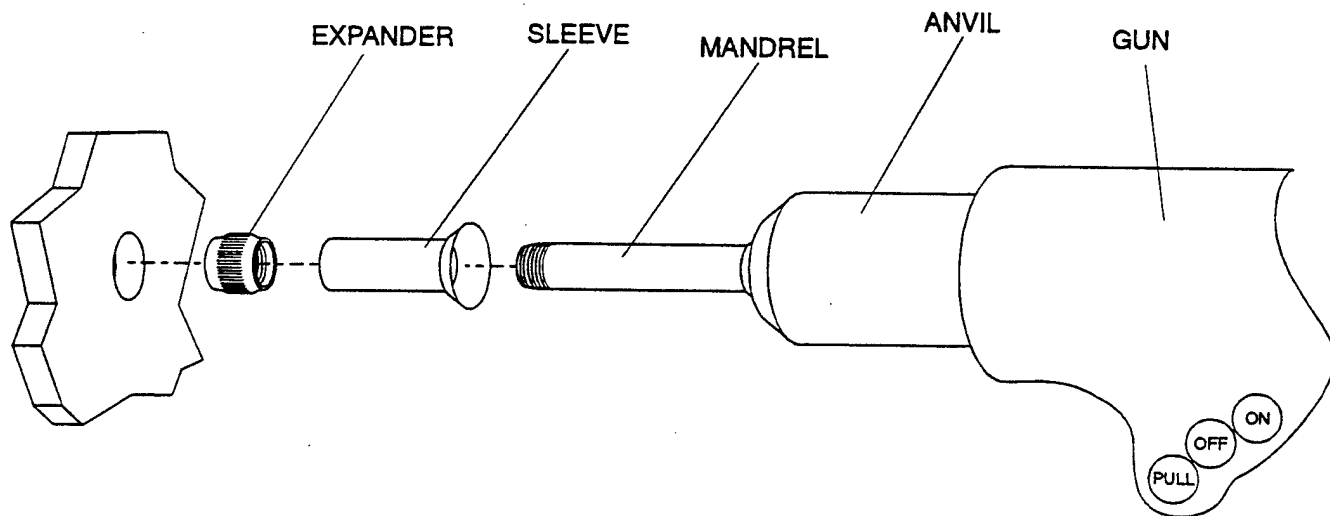

Figure 5-8 Figure 5-5. Gun Lockbolt

- e. Press gun (part no. BG2500, part of BH245-25 assembly) ON (red) control button to screw the mandrel onto the sleeve.
- f. Spin the anvil to seat against the sleeve head and tighten locknut.
- g. Spin the anvil to seat against the sleeve head and tighten locknut.
- h. Insert the assembled expander and sleeve on the mandrel through the hole.
- i. Press gun PULL (white) control button to pull the expander into the sleeve. Gun automatically backs off the sleeve head after the expander pull-up is completed.
- j. Press gun OFF (blue) control button to spin the mandrel out of the installed sleeve and expander.