

Naval Research Reviews

Office of Naval Research
Two/1995
Vol XLVII

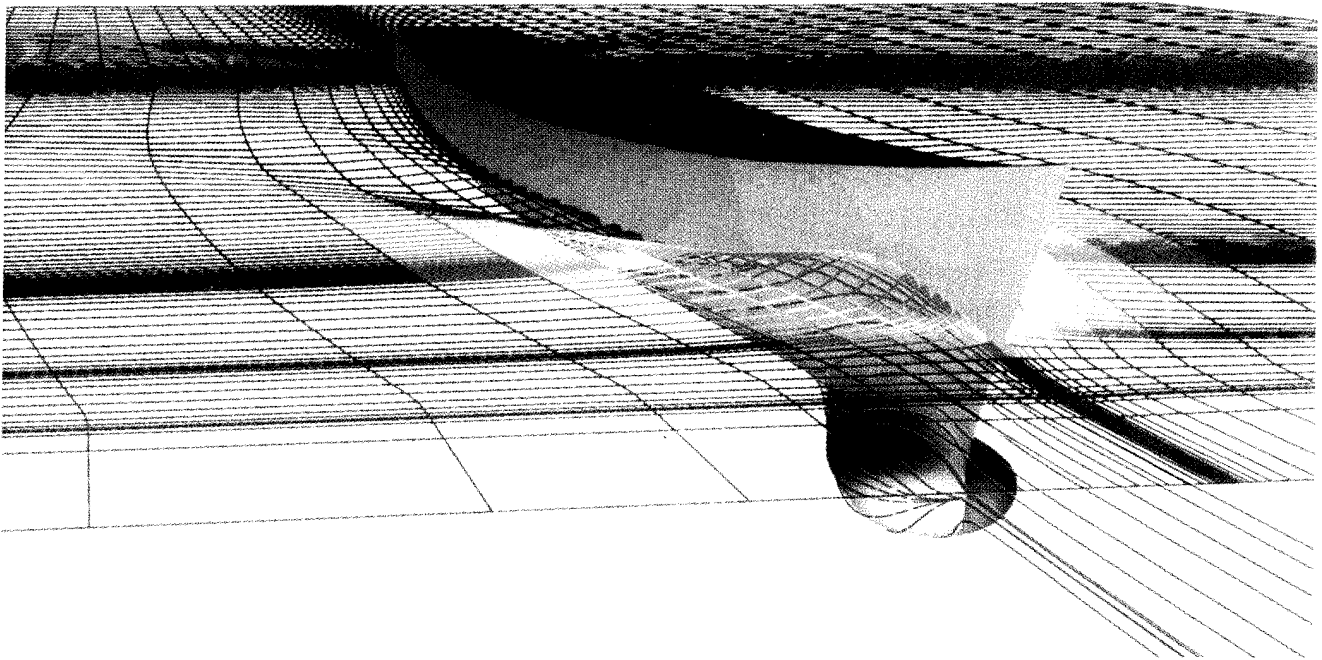

DISTRIBUTION STATEMENT A
Approved for public release
Distribution Unlimited

DTIC QUALITY INSPECTED 6

**Computational Fluid
Dynamics**

19960819 105

AXIS SWITCHING IN THE SQUARE JET

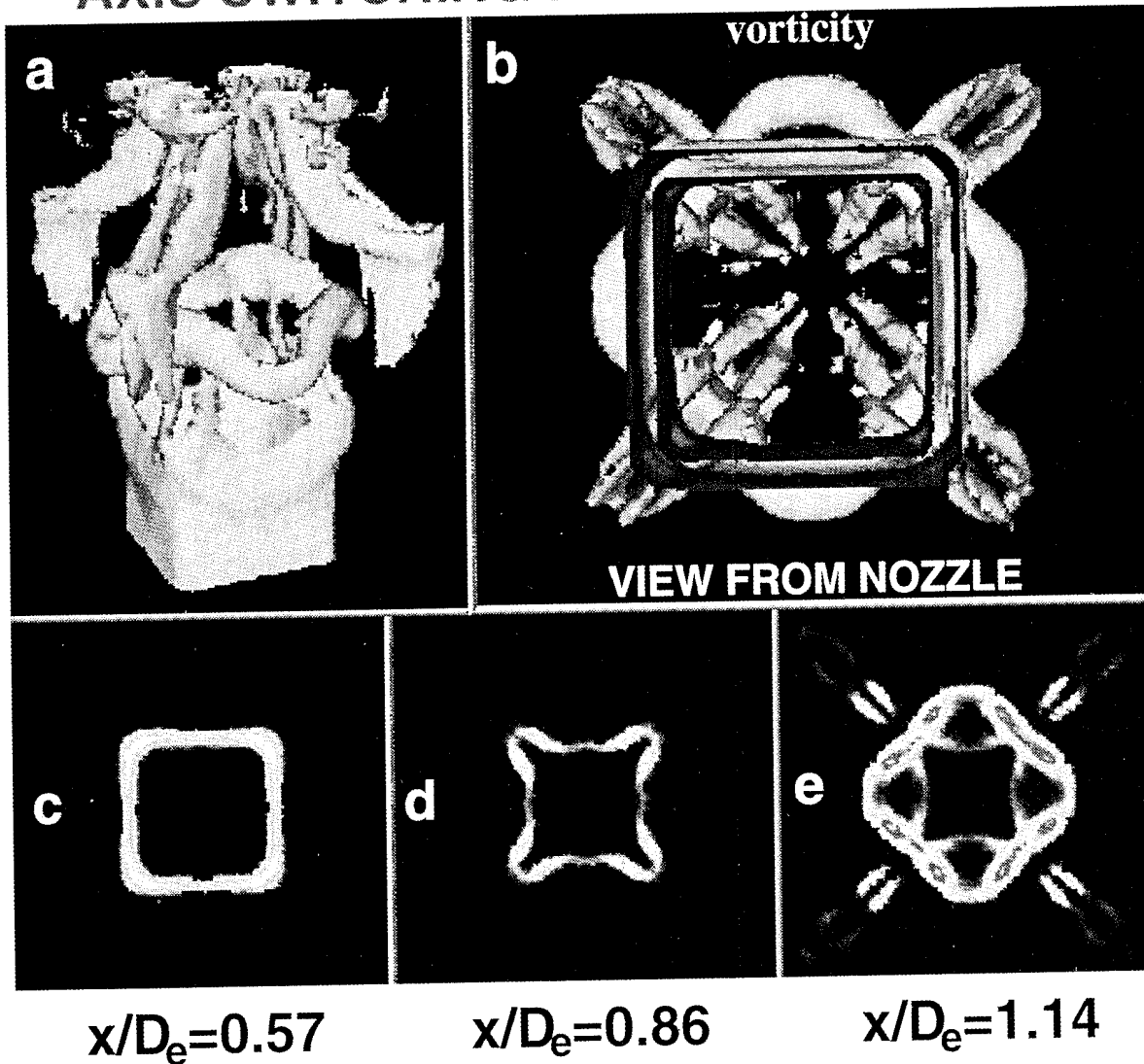

The above figures show the axis-switching process which results in enhanced entrainment and mixing of a jet from a square nozzle when compared to a jet from a circular nozzle. The figure (a) shows the topology of the coherent structures in the square jet in terms of isosurfaces of constant vorticity magnitude. A view from the nozzle (b) and the vorticity distributions at fixed streamwise locations (c, d, and e) show the apparent 45 degree change in the cross section of the jet. Much more than just axis-switching of the rings is involved in the process as seen from the complex topology of the jet shown in figure (a).

Articles

2
**Computational Fluid
Dynamics – Navy Perspective**
Spiro G. Lekoudis

8
**The Emergence of
Computational Ship
Hydrodynamics**
Edwin P. Rood

20
**Turbulence: A Roadblock
to Computational Fluid
Dynamics**
L. Patrick Purtell

26
**Computational Analysis of a
Missile at a High Angle of
Attack**
Robert Van Dyken

32
**Computational Combustion
Approaches to a Complex Phenomenon**
K. Kailasanath and G.D. Roy



CHIEF OF NAVAL RESEARCH
RADM Marc Pelaez, USN

DEPUTY CHIEF OF NAVAL RESEARCH
TECHNICAL DIRECTOR
Dr. Fred Saalfeld

CHIEF WRITER/EDITOR
William J. Lescure

SCIENTIFIC EDITORS
*Dr. Robert J. Nowak
Dr. J. Dale Bullman*

MANAGING EDITOR
Norma Gerbozy

ART DIRECTION
*Typography and Design
Desktop Printer, Arnold, MD*

Departments

19
Profiles in Science

About the Cover

The hydrodynamic flow around the FF1052 as represented by computational ship hydrodynamics; the nonlinear wave deformations are made evident by the grid on the water surface, and the flow around the dome at the base of the bow is depicted by particle trajectories initiated upstream from the hull. (courtesy of F. Stern, University of Iowa.)

Naval Research Reviews publishes articles about research conducted by the laboratories and contractors of the Office of Naval Research and describes important naval experimental activities. Manuscripts submitted for publication, correspondence concerning prospective articles, and changes of address, should be directed to Code OPARI, Office of Naval Research, Arlington, VA 22217-5000. Requests for subscriptions should be directed to the Superintendent of Documents, U.S. Government Printing Office, Washington, DC 20403. *Naval Research Reviews* is published from appropriated funds by authority of the Office of Naval Research in accordance with Navy Publications and Printing Regulations. NAVSO P-35.

Computational Fluid Dynamics – Navy Perspective

*Spiro G. Lekoudis, Guest Editor
Office of Naval Research*

Abstract

Computational Fluid Dynamics (CFD) combines numerical algorithms, fluid dynamics, and computer software and hardware, with the goal of predicting flows. With rapid developments during the last three decades, CFD changed/is changing the design process for aircraft, ships, submarines and weapons. CFD will be important to the Navy, even if it does not impact future developments as prominently as it did in the past. This is the case because, currently, there are no other paths to efficient design of Naval systems whose performance and stealth are significantly influenced by flows.

Introduction

About two decades ago I was learning Computational Fluid Dynamics (CFD) on the job, while working as a research engineer in the defense industry. No university curricula included CFD as a topic in the early 1970s, and, as is the case with novel ideas, the science & technology community was not sure about its potential. I was importing CFD software from the “best available” sources in government and universities, and I was applying them to my problems. It is interesting that this practice, a generation later, is still not universally accepted as the most cost efficient. I had both time-constraints as well as technological barriers and they were as important as the need to publish my work. I had to make sure that design engineers were pleased with the capabilities that I was

offering them! Since time was critical and such capabilities were in their infancy, I had to learn to access the “best and the brightest” and their software in other organizations. CFD is the product of this generation and it is interesting to contemplate what CFD will offer to the Navy as the “CFD generation” is getting closer to retirement! ONR, always involved with the forefront of science & technology, supported members of this “CFD generation” early in their careers.

About twenty five years ago, researchers developed the ideas needed to compute steady subsonic flows with embedded supersonic regions using the assumption of potential flow. In less than a decade the computation of such flows became common in the industry, and CFD changed forever the way aircraft are designed. Such change is occurring in the, much smaller, shipbuilding industry. Although empirical data dominate the shaping of marine vehicles several exceptions exist, such as the use of CFD in designing the winged-keel of racing yachts. The change in the hydrodynamic design process is influenced by increased technological demands that are not easily met by the “cut-and-try” methods, by the power of computers, and by the emerging ability to deal with vortical flows. Unlike the cruise condition of a commercial jet, where very significant quantities, such as lift, can be approximated by potential flow CFD, current supercomputers as well as powerful workstations allow efforts at simulating complex flows, such as interacting streamwise vortices, crucial to Naval technology.

CFD is a combination of fluid mechanics, numerical algorithms, and computer software and hardware, that attempts to simulate fluid flows. The relative importance of these three components of CFD has been changing over the years. Algorithm development dominated CFD in the 1970s, but both its pace and impact is slowing down, as the parallel supercomputer industry enters a more "mature" stage, and load balancing becomes the primary concern of users of such machines. The emergence and availability of parallel supercomputers in the 1980s made them a major driver in CFD development. In the 1990s powerful workstations provide new access to processing power. Algorithm development of a different kind is occurring. These new algorithms are not targeted at flow solvers but implement ideas from optimal control theory to design using CFD and require solutions of the adjoint Navier-Stokes equations. Such ideas deal with the inverse problem in vortical flows. The solution to the inverse problem produces solid object shapes with prescribed constraints on flow loading distributions.

A roadblock that slows the ever increasing applicability of CFD is our inability to simulate turbulence at high Reynolds numbers and for the interesting complex geometries. Thus, the importance of understanding the fluid dynamics using theory and measurements cannot be overemphasized, and all three components are crucial for further developments. Unlike the early stages of CFD development, where the emphasis was in obtaining quantitative information for engineering purposes, CFD is also being used to obtain scientific information, for example, guiding measurements.

The design and operation of surface ships and underwater vehicles require understanding of phenomena that involve incompressible flows, two-phase flows, cavitation, hydroacoustics, and free-surfaces. The presence of moving solid surfaces adds further complication. Predicting and controlling such phenomena can be crucial to the efficiency of various systems and to their stealth. In general the Reynolds numbers are very large, and CFD is tasked to link subscale laboratory data with "full scale" flows around real vehicles. The Reynolds number is proportional to the characteristic velocity and length, while the Froude number is proportional to the characteristic velocity, divided by the square root of the characteristic length. Since the Reynolds number and the Froude number scale differently, either empirical formulas or CFD has to be used for "scaling up". In this way low Reynolds number wave tank data are used to infer data at full scale. It is difficult to achieve confidence in this process, but this extrapolation is probably the most useful function of CFD in ship design. CFD needs to provide information that reduces design uncertainties, and reduces the amount of testing and trial and error procedures that are associated with design. There is another role for CFD in hydrodynamic design. CFD can be used as the extrapolation tool that allows exploration or radical departures from existing designs.

The Navy involvement with CFD started at the Office of Naval Research (ONR) and at the Naval Research Laboratory (NRL). ONR supported both fluid dynamics and numerical algorithms. Several successful CFD methods were supported by the Navy at the early stages of their development, before they became practice in the US and abroad. Examples include panel methods, spectral methods and full-potential transonics in the 1960s and early 1970s, and Euler solvers, multi-grid for Navier-Stokes, spectral elements, unstructured grids, and CFD for parallel computers later on. Research in Computational Physics at the Naval Research Laboratory focused, amongst other issues, on shock waves and reacting flows. The Naval Air Warfare Center, the Naval Surface Warfare Center, and the Naval Undersea Warfare Center develop and implement CFD software for various Naval technology uses, for example platform/weapon loads during weapons release, both in air and underwater.

The remainder of the article emphasizes CFD topics that are important and/or unique to the Navy's mission. The Navy does benefit from CFD developments in general, but there are areas that are of particular importance. Moreover the DoD emphasis on service reliance and the significant CFD activities at NASA and industry help to increase the focus of Navy activities. There is a variety of physics that has been incorporated into CFD software. Panel methods and boundary layer methods continue to be refined, used, and contribute to technology, but will not be discussed because they are mature technology. The focus will be on CFD for the Navier-Stokes equations, which are used at some point in vehicle design process by the sophisticated design teams.

Some Challenging Issues for Navy Relevant CFD.

The incompressibility condition introduces an elliptic constraint in the unsteady (parabolic) Navier-Stokes equations. This constraint has been numerically satisfied in several ways. In formulations that involve vorticity, the pressure is eliminated and the elliptic effect is maintained via auxiliary Poisson equations, or by other means. In methods that involve primitive variables a Poisson equation for the pressure, or a pressure-like variable, is solved. Early formulations date back to the 1960s, although Navier-Stokes solvers were then a matter of academic curiosity. Another approach is to mimic a fully parabolic problem by introducing artificial compressibility. If we confine our attention to numerical algorithms for single processor computers, compressible (and single phase and species) flow CFD is a rapidly maturing subject. Artificial compressibility makes some of the compressible CFD methods candidates for the incompressible problem. Using compressible flow solvers for incompressible flows is, in general, not efficient, due to the time step limitations as the Mach number approaches zero.

Vortical motions and turbulence underneath or at the free surface interact with the free surface, generate waves, and may include complex gas-liquid flows. The chemical effects of surfactants on the surface tension complicate the physics. CFD developments are needed to model such flows, both underwater and with free-surfaces present. Most of the current approximations used involve integral parameters for the interaction of bubbles with the surrounding liquid, and the modification of wave motions from turbulent wakes. Currently parabolized Navier-Stokes are used to compute the evolution of ship wakes, and this evolution is correlated to wave generation. The free surface motion couples with the dynamics of ship motions. CFD could become crucial in understanding and engineering for such motions, especially at high sea states. Such problems are currently beyond the capability of Navier-Stokes to predict. To do that, the sophistication of CFD predictions of large free-surface deformations, including turbulence, need significant improvements.

Surface ships generate rather complex flowfields. Design considerations involve powering requirements, sea-keeping characteristics, and acoustic and nonacoustic signatures. Technologies related to powering and sea-keeping characteristics require knowledge of the near ship flows, especially their dominant (bulk) features. These flows have very high Reynolds numbers, sometimes in the billions. Such Reynolds numbers bring to focus the issues of roughness effects and wall functions in CFD. Dominant feature of near ship flows are the free surface and the separated vortical flows surrounding the hull. Current flow solvers address such flows about realistic hull shapes with fully nonlinear boundary conditions at the free surface and with "conventional" turbulence models. These Reynolds-Averaged-Navier-Stokes (RANS) solvers employ mostly algebraic turbulence models, and the total wave drag predicted agrees with that inferred from the measurements. Computational ship hydrodynamics is an emerging area and is discussed in the article by Ed Rood in this volume.

It is a real challenge to predict similar flows either while the ship is maneuvering, or at high sea states, unless the influence of breaking waves and free-surface turbulence is minimal, and this is a research subject for Navier-Stokes CFD. Current results for such flows are generated using unsteady potential flow methods with fully nonlinear free-surface conditions. Because of the very high Reynolds number unsteady flows of interest, a RANS solution, where all scales are modeled, needs to be investigated. However, due to large scale unsteadiness, it is not clear at this time if a RANS approach, or a Very-Large-Eddy-Simulation (VLES) approach, where most of the scales are modeled, is a superior "predictor". A major additional consideration for the computation of viscous unsteady flows is the severe increase in computing resources required to resolve some of the unsteady phenomena with time accuracy. If the physics issues related to the predictive capability of the software are resolved, the significant new power

of parallel supercomputers will allow routine design procedures to be developed for viscous, unsteady, three-dimensional flows around complex geometries. However the fidelity of such predictions depends on models for turbulence, maybe more so than in "steady" flows. Currently, predictions of unsteady loads via RANS solutions are expensive, not always reliable, and thus a research subject.

The features of small scale free-surface waves are important in remote sensing applications. Thus free-surface turbulence and the effect of surfactants play a significant role in the physics of the small scale features. Simulations have been used to examine the effects of large scale vortical motions on the characteristics of the free surface. Direct numerical simulations of turbulent open channel flow produced turbulence statistics on a free surface, with an unperturbed mean location. The behavior of air-sea interface is part of a larger area where numerical fluid dynamics plays an important role. Oceans are full of dynamic events, and the Navy is very much interested in capabilities that allow prediction of the dynamic behavior of the oceans at all scales. Temperature and density variations, bottom geometry, and air-sea interactions influence such predictions. Given the difficulty of obtaining detailed measured data in the ocean, the role of simulations may be crucial in advancing our capabilities.

In underwater vehicles the designer deals with elongated bodies, where separated flow is present, and where the propulsor operates while immersed in viscous rotational flow. These flows have to be predicted and controlled. In general they are more complex than, for example, attached three-dimensional boundary layer flows. Major considerations include acoustic radiation, ability to listen, and ability to absorb impinging acoustic waves. These considerations involve flow over acoustic sensors, fluid loads that lead to structural vibration and radiation, and flows over coatings that absorb sound. CFD is tasked to help design with acoustics considerations. RANS computation for complex submarine flows task the most powerful of supercomputers, but can, in principle, provide time-averaged and deterministic (i.e. non-turbulent) unsteady pressure and shear loads.

In the submarine world acoustics is extremely important, and flow details that do not contribute much to loads can become significant. Moreover the unsteady nature of the flow has to be considered. This unsteadiness ranges from the large streamwise vortices originating at corner flows and moving while a submarine is turning, to the complex pressure footprints of turbulent structures within boundary layers over acoustic sensors. The unsteady interaction of wakes from control surfaces with propulsors involve complex three-dimensional phenomena that CFD is tasked to predict. The difficulties faced by CFD are illustrated by the following example. Assume that a clever designer could "engineer out" much of the shape that leads to flow complexity. Then with simplifying assumptions, for example potential flow CFD, he

could get satisfactory steady and (maybe) unsteady loads. This would be only a good first step, because designing for acoustics would require additional details. These details, such as surface pressure fluctuations, necessitate sophisticated CFD models that can deal with the unsteady, separated, turbulent flows around modern marine propulsors. RANS seem to be the lowest order CFD model that could give accurate distribution of important unsteady flow quantities over solid surfaces. This is because RANS, with an appropriate turbulence model, can, in principle, capture flow separation from smooth surfaces. Flow separation, large vortical motions, and unsteady loads contribute to noise generation by solid surfaces, as such surfaces move through complex flows. An appropriate remark on this topic is that we should not confuse our inability to model turbulence with the errors associated with neglecting physics. As an example, poor performance by a turbulence model can be addressed in a systematic way, but inadequate separation criteria from ad-hoc assumptions require new assumptions. Turbulence and modeling are discussed in the article by Pat Purtell in this volume.

Hydroacoustic design capabilities, currently under development, would benefit from CFD improvements that can speed up the computation of unsteady flows. Flow loads lead to structural vibrations that can result in acoustic radiation, which invites comparisons with aeroelasticity. Aeroelasticity is important for the design of propellers and helicopter blades and involves large structural deformations that may require truly interactive procedures for prediction and control. In such procedures the structural deformation is predicted by coupling the equations of motion of the deforming structure with CFD. In water, the structural deformation can be orders of magnitude smaller to that in air by comparison, and still produce unwanted acoustic radiation. Important physics for acoustic sensors are due to the fact that turbulent flow events at high wavenumbers, couple with similar events in the structure that are difficult to simulate. Moreover low wavenumber events in the structure, that are easier to compute, couple with low wavenumber, and much lower amplitude events in the flow, that are extremely difficult to simulate with CFD. Thus this linear flow/structure interaction problem is very difficult to analyze, and novel computational methods could contribute to this topic.

Computational hydroacoustics is in an early stage of development, but progressing rapidly. Future coupling of acoustic "sources" where the fluid dynamics and the structural vibrations dominate, with propagating and scattering fields, where computational acoustics is needed, will provide the Navy with enhanced understanding and novel predictive methods. Cavitation and two-phase (bubbly) flows occur in a variety of situations. The acoustic effects of cavitation are important to the stealth of Navy systems, hence cavitation is to be avoided. It relates to the local pressure field, which in turn depends on the flow near solid boundaries and/or wakes.

The development of bubbly flows can be influenced by the surrounding turbulence near solid boundaries. Current engineering CFD predictions rely on empirical mixing of information known from single phase turbulence, with integral parameters that incorporate the density variation present in bubbly flows, or by computing "two species" flows. This is an excellent research area for CFD.

Both surface ships and submarines have to be able to withstand shock waves generated by a hostile weapon. In case of underwater explosions both the shock wave and the subsequent generation of a large gas bubble can inflict damage. Understanding how to design for minimum damage, and/or for maximizing weapon effectiveness requires CFD coupled with prediction of structural deformation and damage. This and other similar nonlinear flow/structure interaction problems are very difficult to analyze. The great variety of the time and spatial scales, and the transient physics, increase the demands on CFD. For example simulating an explosion near a free surface involves the energy releasing bubble gases, the bubble free surface, the ocean surface, the structural modes of the ship, and the structural failure criteria.

Landing on an aircraft carrier in adverse weather conditions requires special attention and knowledge of the forces and moments applied to the landing vehicle. CFD is tasked to provide information about such forces and moments by computing the complex flow around the aircraft/carrier deck geometry. Computing separated vortical flows is a major CFD thrust, especially as we begin to quantify the airflow interaction with moving control surfaces and the loads generated from weapons release. Modern military aircraft were influenced by CFD technology, and they are examples of systems with signature requirements as design drivers. CFD is also impacting the evaluation of mechanical and thermal loads on turbomachinery. Navy Warfare Centers are investigating issues related to missile warfare with CFD, such as vertical launch systems with confined plumes and airframe/missile interactions during weapons release. Missile related CFD is discussed by Robert Van Dyken in this publication.

When turbulence dominates, flow control is not only a most difficult research topic, it is also of great technological importance. In the past CFD had essentially no role to play in flow control of the small turbulent scales. The advent of direct and large-eddy simulations provide new opportunities to examine flow control. The computer, in principle, can be used to speed up the search and confine the parameter space to, hopefully, an area of technological significance. Turbulent shear flows are easier to control when they are away from walls, as opposed to turbulent boundary layers. An example of an effort to use CFD for control, at the research stage, is CFD of simulations of combustion instabilities. Such simulations, together with measurements, are used to develop active combustion control strategies. The topic of computational combustion is discussed by Kailasanah and Roy in this volume.

Such efforts point to how crucial is the coupling of CFD with measurements. The influence of small turbulent scales on the large vortical motions at high Reynolds numbers is a complex issue, and improved understanding via both simulations and measurements may lead to technologically important control strategies. Direct Numerical Simulations of turbulence (DNS), although have solved the "turbulence problem" at low Reynolds numbers, will nor become engineering practice (high Reynolds numbers) in the foreseeable future. However DNS may help with novel turbulence control approaches, where local "event controlling" schemes may be explored. The rapid development of microelectromechanical systems (MEMS), and neural net controllers may help the implementation of such approaches. However, several turbulence control approaches looked good in the Lab but never became practice because the scaling laws were not in their favor .

Additional Remarks.

All of the topical areas that were discussed depend on all components of CFD, fluid dynamics, algorithms and software/hardware. The emergence of parallel supercomputers creates opportunities to develop software with increased performance. Although the time scales for developing and implementing such software for engineering use depend on the objectives of the individual organizations involved, there is a clear path to vastly increased computational power. Another change in computer hardware will also affect the level of sophistication that is acceptable for design. New powerful workstations are increasing the cost effectiveness of sophisticated software.

However, as we demand increased capabilities for predicting complex flows, our dependence on modeling turbulence is increasing. Most of the remaining challenges in flow prediction cannot be overcome unless we understand turbulence better. The fact is that low Reynolds number turbulence can be directly simulated today, and that numerical fluid dynamics is providing information not possible to obtain by measurements. The practitioners and the sponsors of CFD work should make special efforts to identify the sources of disagreement between computations and measurements. For example, there no longer excuse for not knowing that the computation of two-dimensional flow suffers from inadequate numerics, including lack of grid resolution. Then the errors associated with modeling turbulence are easier to assess. Turbulence remains probably as the most difficult unsolved problem in the mechanics of continuous media. We have better numerics and larger computers than the days when predicting attached transonic flows over high aspect ratio transport wings was the forefront of CFD. However in those days the accuracy of the turbulence model was less important; we were primarily interested in the evaluation of integral quantities, such as wing lift, while now we are seeking prediction of local phenomena,

such as heat transfer on turbine blades and species concentration in missile plumes.

The development of appropriate, predictive CFD methods for high Reynolds number turbulent flows is the central issue of CFD. Coupled with the interdisciplinary missions that modern CFD is tasked with brings two major barriers into focus. These barriers cannot be overcome by better numerical algorithms and more powerful parallel supercomputers alone. One barrier is due to lack of good models for turbulence, and for associated multidisciplinary physics, for example, turbulent combustion. Theory is crucial in accomplishing this, and the importance of new theoretical developments cannot be overemphasized. The second barrier is due to lack of measurements at high Reynolds numbers, so that the correct physics can assist the modeling efforts. Facilities such as the ARPA "Superpipe" at Princeton and the new NASA/Industry high Reynolds number facilities (at the drawing board) will contribute to obtaining such data. It is CFD validation, the process by which software and measurements are critically examined to establish the capabilities and limits of the software that will promote further acceptance of CFD. Such validation efforts, costly in resources and time, are absolutely necessary.

Even if we only partially succeed in translating new knowledge about turbulence to engineering tools, CFD has already contributed in another way. CFD driven knowledge about numerical algorithms and supercomputer use is being incorporated into other scientific and technological areas, for example, computational electromagnetics. CFD matured algorithms that are used to improve manufacturing processes, such as the design and analyses of computer chips, to understand the behavior of structures under impact loading, and to improve combustion and energy conversion related technologies. These few examples point to current and future activities that will increase the Navy's ability to perform its mission. Although such activities are not within my definition of CFD they benefit from it, because CFD stands out as an example of how large computers proved useful to DoD in important product development.

Summary.

Computational Fluid Dynamics changed/is changing the platform design process and is influencing several other Navy relevant technologies. This occurred not only because of the capabilities of new supercomputers, but also because CFD reduced the cost of obtaining technologically significant quantities. However, as is the case with all areas of science and technology that compete for resources, its future significance depends on continuing technological impact. There are major obstacles in CFDs very successful path. Current, planned and envisioned computer hardware improvements can help to overcome these obstacles, but, by themselves, cannot remove them. Such obstacles are primarily due to lack of appropriate

models and of appropriate measurements for high Reynolds number turbulence, and for the problems generated when such turbulence affects other phenomena.

Both the engineering and the scientific questions that challenge CFD today are very demanding. In the future, CFD will be part of simulation science and simulation science will be dominant in concurrent engineering and simulation based design (SBD). The vision of combining fluid dynamics with numerical algorithms and powerful supercomputers has already helped the design of new platforms. Moreover, there are currently no alternatives to CFD that satisfy Navy needs in the topics discussed in this article.

Acknowledgements.

A major advantage of working at ONR is the opportunity to interact with premier scientists and engineers involved in CFD. I believe that Naval technologies that involve fluid dynamics have, are, or will be influenced by CFD, and thus by the individual investigators whose ideas created and shaped CFD.

Biography

Spiro Lekoudis is the Acting Director of the Mechanics & Energy Conversion Science & Technology Division at ONR. Before ONR he worked in industry and in academia. He has done research in Computational Fluid Dynamics and has over 40 publications.

The Emergence of Computational Ship Hydrodynamics

*Edwin P. Rood
Office of Naval Research*

Abstract

The field of computational ship hydrodynamics has recently emerged as a result of the application of contemporary computational fluid dynamics to ships and submarines. Computational ship hydrodynamics incorporates a validated numerical process that models as one system the interacting hydrodynamic phenomena in the flow around a marine vehicle. Hydrodynamic flows around marine vehicles are unique because the vehicles are characteristically drag-producing and become dynamic-lift-producing only in turns or at exceptionally high speeds. The vehicles have complex responses to control surface loads as a consequence. Often ship hydrodynamic flows are bounded by free-surfaces and require a solution for the boundary deformation as well as the field variables such as the velocity and pressure. Usually marine propulsors are located in the wake of the hull and appendages, as well as the wake of their own shafts and struts. There is a strong interaction between the flow around the hull and the flow through the propulsor and the rudder. As in many other engineering areas, the availability and the exploitation of supercomputer resources has provided the needed breakthrough to rationally analyze and design complex ship hydrodynamic systems. Recent computational milestones include the steady hydrodynamic flow around propelled surface ships and the design of complex integrated stern/propulsor systems. Numerical capability has produced results that are more detailed than existing measurement data; hence there is a need for new, more accurate, highly resolved measurements of the unsteady flow around large model ships in towing tanks and maneuver-

ing basins in order to validate and calibrate the computations. In the near future computational ship hydrodynamics will be an integral part along with traditional towing tank tests for design conception and evaluation. In the not-too-distant future the naval architect can expect to use a numerical towing tank as the primary design tool, with the towing tank providing calibration and limited validation at model scale for the final design.

Introduction

Fluid dynamics is a venerable subject occupying the scientific minds of mathematicians, physicists, and engineers. Fluid dynamics as a modern science arguably dates from 1500 with Leonardo da Vinci's flow visualizations (Lugt, 1983). Four hundred years later, the modern age of the supercomputer has been a revolutionary period for fluid dynamics. As recent as 1980, only visionaries anticipated that numerical simulations of the physics of such flows as three-dimensional turbulent jets interacting with the free surface (Mangiavacchi, et al., 1994) and wave interactions with turbulent patches on the free surface (Dommermuth, et al., 1994) would be commonplace in 1995. This article is about how computational fluid dynamics is impacting the field of naval ship hydrodynamics, and about how and why the emergence of computational ship hydrodynamics from a numerical supplement to a numerical complement to towing tank tests will lead to a turn-of-the-century revolution in the design process.

Ship hydrodynamics is similar to airplane aerodynamics in many respects, especially in the needs to properly grid the

Figure 1.

Characteristic Free-Surface Features of the Hydrodynamic Flow Around a Ship.

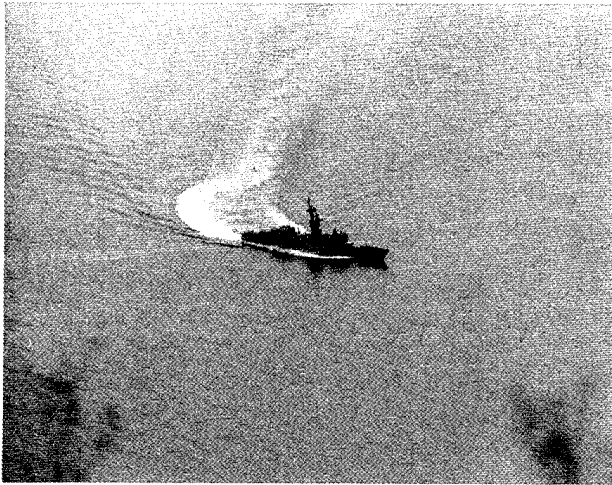

vehicle geometry, to utilize an appropriate turbulence model, and to account for flow separations, and unlike airplane fluid dynamics in many other respects. For instance, ships and submarines are essentially drag bodies with the propulsor in the wake of the vehicle whereas airplanes are lifting bodies with the propulsors in front of the body. Flow features such as the free surface and two-phase flows, shown in Figure 1, must be included in computational ship hydrodynamics whereas those features are absent from airplane aerodynamics. Marine propulsors are characterized by complex geometry featuring strongly three-dimensional flows, whereas aircraft propulsors feature flows more two-dimensional in character. These dissimilarities between ship hydrodynamics and airplane aerodynamics have led to the specialized field of computational ship hydrodynamics.

This article is directed at scientists and technologists with little background in fluid dynamics as well as to computational ship hydrodynamicists interested in the larger role of numerical methods in science and technology and Navy R&D. The article continues the perspective generated by Lekoudis (1993, 1995) but focused here on ship hydrodynamics. The article is long on the role and technological implications of computational ship hydrodynamics and short on the description of numerics. It is an overview with selected illustrative examples of recent milestone accomplishments including computations of the fully nonlinear free-surface turbulent flow around a combatant surface ship, the computation of the propeller-hull interaction and in particular the elusive "effective wake", and the computation of the flow around a sailing yacht at yaw including the lifting surface keel. In addition, examples of very high resolution simulations of selected phenomena in the flow around a ship are presented. These high resolution simulations

are used to obtain coefficients for models embedded in the numerical method for predicting the overall flow around the ship.

The Equations

The future for computational ship hydrodynamics is in the numerical solution of the unsteady Reynolds-Averaged Navier-Stokes (RANS) equations in which the complete Navier-Stokes equations for a fluid are approximated by assuming the flow is incompressible and by modeling the Reynolds stresses (the "turbulence"). It turns out that these assumptions do not practically affect the validity of the equations for ship hydrodynamics. The equations are solved subject to the boundary conditions presented by the ship hull and the environment, such as the deformable free surface and the muddy ocean bottom.

The unsteady RANS equations are the momentum equations, or the equations of motion, for the fluid:

$$\frac{\partial \vec{u}}{\partial t} + \vec{u} \cdot \nabla \vec{u} = \frac{\nabla p}{\rho} + \nu \nabla^2 \vec{u} + \nabla \langle u' u' \rangle$$

where

$$\langle u' u' \rangle = u_i u_j \quad (i = 1, 2, 3; j = 1, 2, 3)$$

is the nine-component velocity correlation tensor for the turbulent velocity fluctuations; it is the Reynolds stress tensor. These equations (one for each coordinate direction) admit important flow characteristics including stratification, temperature distribution, and bubble clouds with the appropriate coupled equations.

The unsteady RANS equations are obtained by averaging over characteristic times longer than the turbulence characteristic time yet shorter than the characteristic time for ship motions. The equations predict motions corresponding to ship turning, propeller rotation, and wave encounter while accounting for the averaged effect of small scale random motions. The Reynolds stress represents the average effect of the small scales, and is obtained by averaging the nonlinear velocity term in the Navier-Stokes equation. Hence it is an inertial term rather than a viscous term. It is the Reynolds stress for which models are sought in the quest to "solve turbulence" (Purtell, 1995).

The RANS equations are solved subject to mass conservation and the boundary conditions. The boundary conditions are specified on all the boundaries of the fluid, including the ship hull, the deformable free surface, and the bottom and sides of the fluid domain. Often the sides are considered to be sufficiently far from the ship that they do not have a direct effect on the flow around the ship. In this case the boundary of the fluid is the boundary of the numerical grid, and condi-

Figure 2.

Photograph of the Complex Stern, Propeller, Strut, and Rudder Geometry Leading to Complicated Three-Dimensional Flow Interactions.

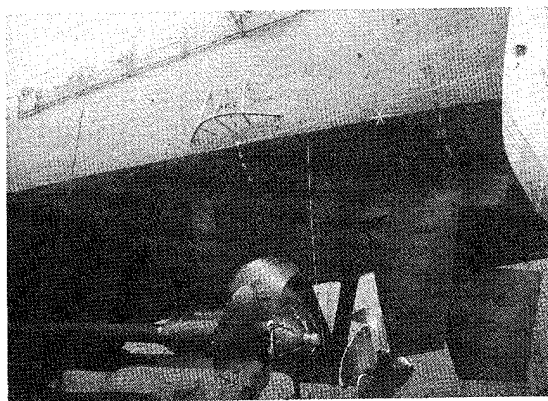

S. TONE N/M 85LPI 45" TABLE 1

CV= 1 MX= 70% MY= 70% S= 03

DMIN=0.17 DMAX=1.29 HL= 10% SHD= 75% HB=0 SB=0

tions such as no wave reflection and no streamwise gradients of flow quantities are imposed at the boundary of the grid.

The hull boundary conditions are expressed as a consequence of the "no-slip" condition which specifies that the fluid at the surface of the hull assumes the velocity of the hull. This leads to regions near the hull, and in shed vorticity, in which the flow exhibits very large momentum gradients. There is then a wide range of length scales to be resolved by computations of the flow. The range of scales is effectively defined by the Reynolds number (the ratio of the inertial to the viscous forces), with the range increasing rapidly with increasing Reynolds number. The Reynolds number is small in laboratory experiments, moderate in towing tank tests, and very large for full scale ship hydrodynamics. These high gradient regions cannot be ignored because they are the boundaries between the bulk fluid field and the hull and hence transmit the fluid force to the hull, and because they are the sources for various flow interactions as the high-gradient fluid is advected downstream.

The free surface is a material surface boundary to the liquid flow domain on which additional boundary conditions are imposed. Those conditions range from the simplest, in which the surface is considered to be a constant pressure boundary with zero viscous stress, to more complex in which the wind-induced viscous stress is included in the boundary

condition. Even in the simplest case, the presence of the free surface complicates the computation because the location of the free surface must be determined as part of the solution to the problem.

Submarines are included as "ships" in this article. Although in many cases, such as deep submergence, free surface effects are absent, the submarine hydrodynamics are characterized by their own peculiar features attributable to the wake inflow to the propulsor and to unusual motions caused by high incidence angles to the flow and irregular flow separations during maneuvers.

The Essence of Computational Ship Hydrodynamics

Computational ship hydrodynamics includes the collection of numerical methods, the verification of the methods through study of the convergence characteristics of the numerical methods, and the validation of the computed results by physical measurements. Convergence studies and validation measurements are necessary because the numerical methods are alternative representations of the equations for the flow, and feature dynamics dictated by their method of solution as well as by the flow physics. It is possible for a method to converge to the wrong answer, or to give a seemingly reasonable answer which is grid dependent and hence not converged.

The naval requirement is to understand the details of the flow around marine vehicles at several levels. At the coarsest level, knowledge of the accurate time-dependent evolution of the macroscale flow over the body, especially including interference effects of appendages and propulsors, is required to determine forces and moments during maneuvers. Even at this coarse level the complexity of the ship geometry, an example of which is shown in Figure 2, leads to very complicated three-dimensional flow interactions. The computed forces and moments must be sufficiently accurate that they can be used to predict and control surface ship motions in response to a seaway, and submarine trajectories for extreme maneuvers, such as might be expected under emergency situations. At a more detailed level, a prediction of the accurate time-dependent evolution of the flow details into the propulsor is required for acoustic design. These details include, for example, the spatial distribution of the inflow to the propeller. This spatial distribution, which appears as a time-dependent flow in the rotating coordinate frame of the propeller, is required to predict vibrations of the propeller. Inherent in the computation of the inflow for marine vehicles is the need to correctly predict the evolution of the vortical wakes produced by upstream disturbances such as appendages and even by the hull if it is inclined to the flow. Hence the computational method must not be overly dissipative. At the most detailed level, the accurate simulation of the microscale evolution of the flow is

required. Such simulations are used for example to reproduce the flow as a numerical measurement for the calibration of turbulence models.

The process of computing the hydrodynamic flow around a ship begins with the specification of the ship geometry. This first step is crucial. The ship hull, appendage, and propeller geometry defines the boundary to the flow; small changes in the geometry can, under appropriate circumstances, lead to significant changes in vehicle performance. Discontinuities in the geometry can produce disproportionate disruptions to the computed flow. The geometry is developed initially in computer aided design applications, and includes highly resolved interfaces between such components as the hull and appendages.

The next step in the process is the conversion of the flow volume and boundary surface geometry to a discrete grid. In this step the continuous ship geometry is transformed to a numerically similar array of points in space according to the complexity of the geometry and the anticipated flow. The fluid volume and the deformable free surface are also transformed to a three-dimensional array of points in space representative of the actual continuous fluid domain. The creation of the grid is a major consumer of resources, especially in the case of time-dependent flows in which the grid must be adjusted at each time step to account for the evolving flow, such as the changing free surface deformation or the downstream movement of vortices. The grid must be sufficiently fine to resolve space and time details but must facilitate efficient computations and not lead to unstable or nonconverged solutions.

In the next step, the equations of motion and mass conservation are discretized and coupled to a numerical solution method. The discretization and solution method can be any one of a number, including finite volume and finite difference methods. The discretization is a numerical approximation to the analytic equations; inversion of the discretized equations produces a mathematical expression only approximating the initial equation. It is expected that the solution first obtained is not the desired representation of the actual flow. A crucial check on the approximation is convergence with changing grid size and with iterations in time. The numerical solution is "unstable" if the computations become unrealistic as the convergence is pursued. Stability is essential for the computations to produce a meaningful answer and can sometimes be obtained by increasing the effective damping in the numerical solution method. A stable numerical procedure is "robust". However, there is a critical balance struck between the damping necessary to stabilize the equation solutions and the marginal stability required to retain flow details. For example, robust and over-damped computations will cause vortical motions to decay unnaturally and lead to false conclusions regarding the

effects of upstream-generated vorticity on downstream flow features.

The next step in the computational process is the presentation and communication of the computed results as useable information. This step is a major problem: the flows are complicated and the geometry highly complex, and the data space is multidimensional including geometry, velocity, pressure, temperature, density, and derivatives such as vorticity. Analysis of this information requires very sophisticated visualization processing, that can render iso-surface contours and perspective views "instantaneously." Such "post processing" is always accompanied by three-dimensional visual presentation of the data, usually generated by sophisticated computer workstations. Characteristically such information appears as visual tracking of flow particles as they move in time through color-coded pressure regions, with changes in views and perspectives being made "instantaneously". Virtual reality will soon have an impact by permitting the analyst/designer to virtually walk around the flow and observe phenomena. This observation is crucial for the full exploitation of computational ship hydrodynamics.

The final step in the process of computing the hydrodynamic flow around a ship is the validation of the results. A limited set of physical measurements is required to provide assurance that the computations are useable for analysis and design. Within a reasonable latitude, such measurements can be used to actually calibrate the computed solution; for example, certain turbulence model coefficients may be set by the measurements. The process that led to the validated solution can then be safely repeated to develop a data base for various conditions.

In time, and with extensive experience, the validated computational ship hydrodynamics process can lead to a certified process able to be relied upon for absolute engineering solutions. Computational ship hydrodynamics has not realized this state of maturity.

Towards a Numerical Towing Tank

Computational fluid dynamics has reached a level of sophistication and validity such that it is routinely used to compute hydrodynamic flows around various components of the ship, such as the hull, the appendages, and the propeller. The next important step is to combine the computational methods into one or more comprehensive computational methodologies and techniques, or computational ship hydrodynamics. Such a computational ship hydrodynamics capability is technically feasible today as a tool useable by the design community.

Experience with successful applications of computational fluid dynamics to real-world problems has demonstrated the need to form a group of individual specialists dedicated to

Figure 3.

Photographs Comparing Free-Surface Features Observed for Full Scale CVN68 and for a Model CVN68 in a Towing Tank Test.

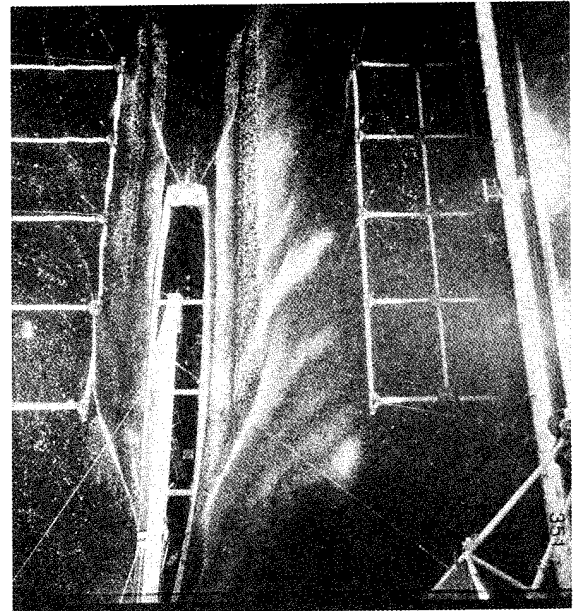
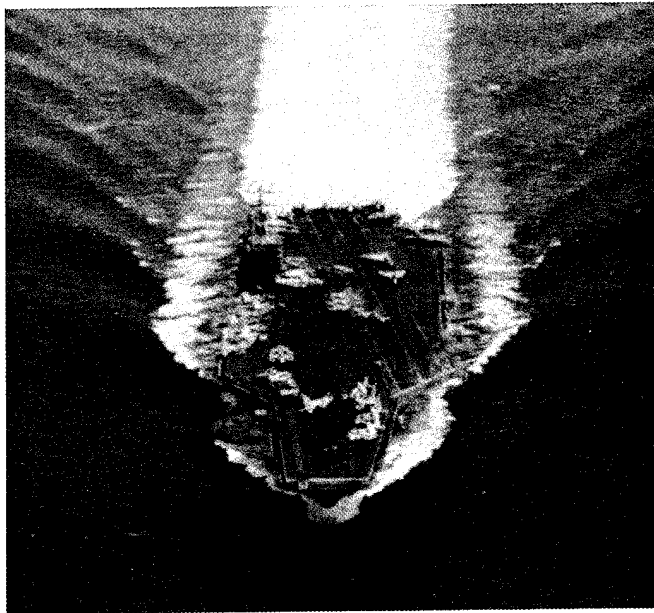

applications-driven research (Whitfield, 1995a). This management concept is contrasted to modified matrix-management often advocated but usually lacking the dedication characteristic of a team. In particular, experience indicates that the Navy is best served by a hydrodynamics center devoted to computational ship hydrodynamics. This center would gain experience as the individual specialists (grid generation, turbulence models, wake simulation, post-processing, etc.) work as a dedicated team on a variety of problems. The Navy has established the Hydrodynamics/Hydroacoustics Technology Center at the David Taylor Model Basin in Bethesda, Maryland, to address the implementation of computational ship hydrodynamics in the design world.

Of all the hydrodynamic components on a ship, the propeller has been the most designed by numerical computational methods. Propeller design traditionally includes a substantial reliance on computational fluid dynamics in combination with experience. Numerical methods ranging from lifting line to obtain spanwise blade loading, lifting surface to design the chordwise loading, and (more recently) panel methods to design to avoid cavitation are used to obtain a set of geometries which are evaluated in water tunnels for applications. Computational ship hydrodynamics is now admitting the capability to predict the combined interaction flow for a propelled ship. It is anticipated by naval hydrodynamicists that the role of computational ship

hydrodynamics will become increasingly more visible and credible. The rate at which there will be increased utilization of computational ship hydrodynamics is regulated more by perception of validity than by technological capability.

Computational ship hydrodynamics has reached a level of maturity at which it can be used for sorting various real-world designs at least for a relative ranking. The expectation in the hydrodynamics community is that computational ship hydrodynamics can and should be a major tool for the conceptual and preliminary designs for the next surface combatant (SC-21), and that this tool will prove essential for problem-solving in response to towing tank test results for designs.

The computational ship hydrodynamics approach is developed for a particular range of geometry and operating conditions. This specialization is required for the foreseeable future because of the sensitivity of the results from computational methods and models to geometry and flow conditions. The methods are necessarily marginally stable to ensure maximum fidelity of the computations. The procedure is to calibrate the computations with a limited set of towing tank measurements, such as the straight-ahead operation in calm and moderate sinusoidal waves for one set of operating conditions. The calibration is not complete because the model scale flow is not the same as the full scale flow, in part because of the incongruence of modeling both the gravitational and viscous forces simultaneously. Nevertheless, the model scale flow exhibits features similar to those found on full scale, as

shown in Figure 3 comparing full scale and model scale features.

Once validated and calibrated for the design condition, computational ship hydrodynamics can be used to analyze geometry modifications and off-design operation including maneuvers. For example, wake-adapted propulsors designed for minimum unsteady loading in the straight ahead condition may be better optimized over a range of angles of incidence produced by maneuvers or by waves. Designs can incorporate the range of parameters expected under normal operation rather than being focussed on the "straight ahead" condition with heuristic knowledge incorporated into the design.

In the world of computational ship hydrodynamics, there is no practical limitation on the scale for the ship. Therefore the computed model scale data can be scaled to full scale values useful for design. This procedure does not entirely remove the empirical "correlation" connecting model scale and full scale results, but it does significantly increase the confidence in the results because the scaling is physics-based. This is especially important if the information desired lies outside the historical parameter range.

Computational ship hydrodynamics can be utilized in several ways to impact design and analysis. The following several examples serve to illustrate some of those ways.

Ship motions, and in particular rolling motions, are greatly affected by the viscous and turbulent damping of the motion by the water. This damping depends on the Reynolds number, which is very large for full-scale ships, and small for model scale ships. Once validated with model scale data, computational ship hydrodynamics produces the crucial damping information required to predict full scale motions.

Computational ship hydrodynamics provides the tool to explore the effects of nonconventional geometry on ship performance. For example, catamaran and trimaran configurations applied to modified monohulls for wave cancellation, and radical bow shaping for wave-piercing, including sweep down rather than sweep up, are approachable with computational ship hydrodynamics. Computational ship hydrodynamics is already being used to evaluate modifications to the bow sonar dome for the DDG-51 as an "after the fact" demonstration. The original modifications were made based solely on towing tank tests, and were limited by resources to a selected set of geometry. The goal with the demonstration is to examine the accuracy of a numerical process, and perhaps to result in a better design for the modification.

Computational ship hydrodynamics can be employed to develop control systems, and in particular by providing force and moment loads for input to control system design and optimization especially for cases of extreme maneuvers. It is very difficult to obtain required towing tank (or more specifically, maneuvering basin) model data for free-running models. A particular problem to anticipate by design or operation extreme maneuvers for submarines, or other appended bodies of revolution. Typically

predictions are made using system identification techniques, and validation of the design is attempted by measuring trajectories for free-running models. Computational ship hydrodynamics permits the scaling of the results to full scale, and is a technique for analyzing the flow round the body to determine the causes of unfavorable loadings. Alternative physical measurements of the details of the flow are very expensive in both money and time.

Another example concerns the design of propellers. Currently they are designed using a variety of specialized and nonintegrated computational methods, developed piecemeal over years of development. The movement is toward flow solvers that capture all the features, but compute only what is needed. For example, gridding can focus on regions of the flow of interest with large density grids, with much smaller density of gridding elsewhere, to capture the major effects on the region of interest.

A significant step towards a numerical towing tank will soon take place when "simultaneous" towing tank measurements and RANS computations will be made with the self-propelled DTMB Model 5415 Surface Combatant. The computations and measurements will leap-frog to guide the entire investigation toward an archival database of information on propeller/hull interactions, flow separations, wave breaking, and transom stern flows in support of advanced surface ship designs.

Computational Ship Hydrodynamics Today

In the selected examples that follow, it is shown that the complicated three-dimensional flows around various components of ships are represented by computational ship hydrodynamics. All of the cases discussed below consider the turbulent flow around the ship by including the Reynolds stresses. The flow solvers are generally known as "fully nonlinear free-surface RANS codes" or more simply as "RANS codes" in the case that the free surface is not a factor. All of the computational ship hydrodynamics computer codes include time in the solutions. In the case of steady motions, evolving time is used to arrive at the steady motion and may not be an accurate representation of real fluid motion as a trade-off for computational efficiency. Although sophisticated computational methods that neglect turbulence are used for computational fluid dynamics, and will always have a proper place in design methodology because of the reduced computational resources required, the proper prediction of the flow by computational ship hydrodynamics for final design or for analysis must include turbulence.

Recent examples of computations for surface ships include the prediction of the nonlinear free-surface turbulent flow around a modern naval combatant by Stern, et al. (1995) and around a sailing yacht by Farmer, et al. (1995). The

computation around the surface combatant features the effects of the bulbous bow and the transom stern. A sample result from the computation is shown in Figure 4. As with all the advanced computational methods, the discretization of the entire flow field permits the full interaction of the low speed boundary layer next to the hull and the wavemaking on the free surface. The computations predict a "double rooster tail" associated with the two peaks in the free surface just aft of the stern. A comparison with measurements obtained in a towing tank test shows that the twin peaks are present in the real flow. In the second example the computations for the sailing yacht include the effects of yaw angle, in which the flow around the submerged keel, acting as a wing, generates a lifting force and a downstream trailing vortex that interacts with the rudder. Simulation and modeling of these types of interactions are essential for the prediction of the inflow to propulsors and rudders, and for the appendage interactions on maneuvering submarines, especially near to or broached at the free surface. The numerical procedure that produced these computations is expected to be applied to the America's Cup designs for 1999 in what promises to be an intense effort by the United States to reclaim the trophy.

Computations of the flow interaction between the ship hull and the operating propeller have been made by Stern, et al. (1994) for a full domain solution and by Weems, et al. (1994) for a partial-domain solution (in which the flow away from the hull is approximated by inviscid flow) for a ship model used by the International Towing Tank Conference for comparison of measurement and computation methods (Series 60, $C_b = 0.6$). In both cases the propeller flow is computed using potential flow methods that do not fully account for the viscous, turbulent flow but do predict the lifting force on the propeller blades. This force is embedded in the RANS computations as a body force, distributed azimuthally and radially as appropriate in the propeller disc region. The result is that the interactive effect of the propeller and the hull is captured in the computations. This is an important effect required for propeller design; it arises from the suction effect of the propeller on the hull, which changes the momentum distribution of the hull boundary layer upstream from the immediate region of the propeller. The change in the upstream boundary layer momentum then appears as a change in the effective open-water inflow to the propeller, leading to a change in propeller loading. Propeller design depends on the proper accounting for this effective wake, which is not measurable. Comparisons of computed and measured velocity profiles for the flow around the propeller demonstrate that the flow is qualitatively captured by the computations, but that detailed resolution of the flow is missing. The results will be improved with better turbulence models and higher resolution computational methods, and these are active research areas.

The marine propeller is a complex geometry with a complicated flow. Specialized computational methods have been

Figure 4.

Results of Computation of the Free-Surface Deformation of the Flow Around the FF1052 at Froude Number - 0.3 and Reynolds Number 4,000,000.

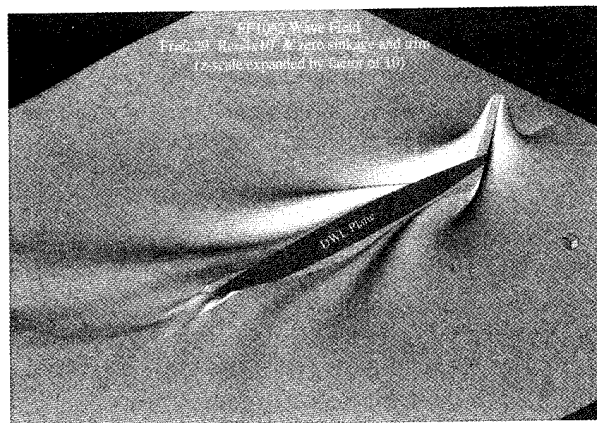

applied to the propeller and its interactions with the flow around the ship. Clearly modern propellers with large three-dimensional curvatures to the blades and possibly with a surrounding duct are complex geometries. Specification of these geometries, and the maintenance of the surface integrity in gridding of the surface is a specialized subject. The details of the propeller, such as the intersection of the blade root with the hub and the clearance between the blade and the duct, must be precisely specified in cases where the vortical flows in such regions can lead to nuisance cavitation. The complex geometry produces a complex flow which is made more difficult to predict by the interactions between the propeller flow and the flow around the hull as described above. The need for even higher performance propellers has led to the need to predict the hull and propeller flow simultaneously. Kerwin, et al. (1994) have developed a design method for complex propulsors which includes a rational B-spline method for geometry specification as well as a blend of RANS computations for the axisymmetric inflow and a lifting surface method for the blade loading. Figure 5 shows a geometry characteristic of modern propulsors. There are very significant flow interactions between the components, including the blade-to-blade and blade-row-to-row, and the upstream boundary layer and the flow through the propulsor. Such designs are further complicated by the full integration of the propulsor and the stern appendage flows. With this type of integration the stern and appendages and the propulsor, considered separately, will not meet requirements. But the combination, working together, does meet the requirements. To compute the flow for these types of arrangements it is necessary to consider the full turbulent flow through the system.

Significant and substantial progress has recently been made in the computation of the unsteady turbulent flow around

Figure 5.

Drawing of the Complex Geometry Characteristic of Modern Turbomachinery-Like Propulsors.

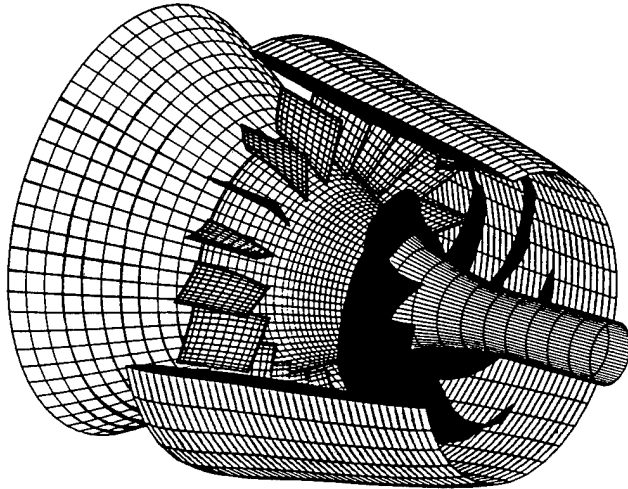

a propeller. (Stern, et al., 1994) describe a computational method for steady flow around a marine propeller with a large amount of curvature to the blades. Such a highly three-dimensional geometry produces complicated three-dimensional flow separations, which contribute to blade passage vortices and the wake of the propeller. The computational method was validated with experimental data and found to be at least as accurate as the existing inviscid computational methods. The added capability of this RANS method is the prediction of the turbulent viscous wake without approximation, except for the turbulence model. It is expected that such methods, free of the artificial models incorporated in inviscid models, will accurately treat complicated geometry such as that shown in Figure 5. A companion paper by Chen, et al. (1994) describes a successful attempt to compute the unsteady flow around a lifting surface. This method is being extended to the complete flow around a propeller operating in a spatially nonuniform inflow.

The computation of flows around submarines generally excludes the need to include the free surface, but necessarily includes increased emphasis on predicting vortical flows. These vortical flows arise as the lifting surfaces used for control generate trailing vortices both at their root and tip ends as the consequence of lift, and at their root in addition as an interaction with the hull boundary layer, and along the hull if it is at incidence to the flow. These vortical flows interact with downstream surfaces, such as other appendages and the propeller. The computational burden is to accurately predict the evolution of the vortical flow, which is characterized by large velocity gradients and the suppression of turbulence in the

core. Computational methods must not be overly dissipative or the vorticity will artificially dissipate; hence the computer codes are very sensitive to moderate changes in input.

RANS computational methods have been successfully used to model the separated flow around a body of revolution at an angle of incidence. This flow is complicated by the three-dimensional flow separations that occur along the sides of the body. Such separations are difficult to model because the flow detaches from the smooth surface of the body rather than from a sharp edge defining the point of detachment. Sung & Huang (1994) have produced validated computations for the forces and moments on the body at incidence for large model-scale Reynolds numbers. In order to achieve the successful computations, it was necessary to customize the turbulence model for the appearance of the longitudinal vortices generated by the flow separations. Submarines have appendages, which must be included in the full computation of the flow around the submarine. A chief difficulty is the prediction of the flow around the intersection of the appendage with the body. Such intersections produce a roll-up of the boundary layer fluid along the body to produce horseshoe vortices wrapping around the leading edge of the appendage. The consequence is that the boundary layer is inverted downstream from the appendage. This feature must be captured by high spatial resolution computations. An efficient solver for this flow has been validated with experimental data (Sung & Huang, 1994). The solver utilized multiblock, multigrid, local refinement, preconditioning, and adaptive artificial dissipation models to achieve 90 percent savings in both memory and cpu time. Such efficiencies are required to permit practical computational ship hydrodynamics applications.

The research group at the Applied Research Laboratory/Pennsylvania State University has been using unsteady RANS flow solvers for unsteady motion to determine the forces and moments on a submarine (see Figure 6). With this information, predictions of the trajectory of the submarine are possible. This work is ongoing, and it is expected that the computations will be used to design a validation test in which the computed and measured trajectories will be compared in the near future. Current research with surface ships is also emphasizing time-dependent solutions. Particular interest is focused on turns in shallow water, and the effects of channel crossings.

Surface ships are characterized by motions induced by interactions with waves as well as by maneuvers of the vehicle itself. Recent efforts to predict ship motions include the effects of curved hulls in the transverse cross-section and the transom stern. These geometry features have important effects on the motions and loads on ships because they are major factors in the hydrostatic loading and the viscous flow. The state-of-the-art for ship motion computations is inviscid panel methods. These methods rely on various boundary integral formulations to represent the flow around the ship. Viscous effects

Figure 6.

Computed Flow Trajectories for a Submarine-Like Body Undergoing Sudden Pitch (Whitfield, 1995b).

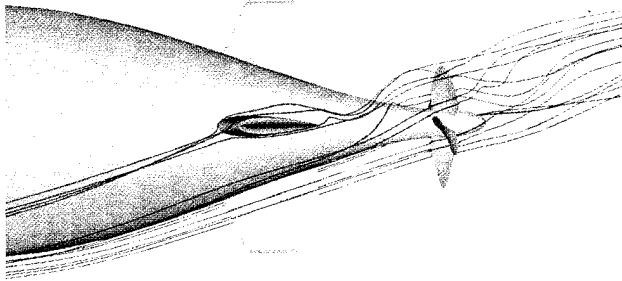

are accounted for at the stern by enforcing a Kutta condition so that the flow smoothly exits from the hull. Sclavounos, Nakos & Huang (1994) have developed a robust computational method (SWAN) that treats the unsteady frequency domain ship motion problem as a linear perturbation of the nonlinear solution. SWAN accounts for three-dimensional flow effects for hulls with flare and transom sterns, and preliminary results show very good agreement with experimental data for pitch and heave motions. The inviscid methods are more suited for pitch and heave than for roll and yaw, which are dependent on viscous effects along the entire hull and require a full treatment of viscosity and turbulence. Nevertheless, the inviscid SWAN method is currently under validation studies as a significant improvement to the current two-dimensional methods used for traditional ship motion design. A significant research effort is underway to develop and apply unsteady RANS computations to the rolling motion of a surface ship in a seaway. The damping of roll motion is strongly dependent on the viscous turbulent flow and cannot be represented by inviscid methods.

Numerical Simulations and Surrogate Models

Computational ship hydrodynamics is based on solutions to the unsteady RANS equations. It is not possible with those equations to explicitly compute all the details of the flow. The equations themselves are averaged over a short characteristic time, a process that inherently loses detail. A more practical problem arises in consideration of the computational resources in both time and hardware that would be required to compute the details for short characteristic times as well as the longer ship motion time scales. In practice, models are used to reproduce the effects of the small details of the flow on the macroscale features. These models can be obtained through interpretation of physical measurements or of direct numerical

simulations of the flow. Numerical simulations are often preferred because spatial and temporal resolution can be greater than in a physical measurement, and because many variables can be computed which are not easily measured (such as the pressure-velocity correlation). As much as computational ship hydrodynamics is not complete without the performance validations at the end, it is also not complete without the simulations and modeling required at the beginning to develop the equations to be solved. There are two examples considered here, the simulation of the disconnection of the vortex ring as a turbulence mechanism and the modeling of the turbulent wake of the spilling breaking wave as a RANS surrogate model.

Vortex Disconnection

Free-surface turbulence models are needed to represent the evolution of the turbulent flow near the free surface. In this case the boundary is shear-free, and is different than the no-slip boundary characteristic of the turbulent flow along the ship hull. A fundamental mechanism for free-surface turbulence is the vortex disconnection event during which vorticity appears (or disappears) on the free-surface boundary of the fluid. This process is analogous to the hairpin vortex mechanism underlying solid body boundary layer mechanics. Observations of the event were first made for a vortex ring interacting with the free surface (Bernal & Kwon, 1989); a mechanism was postulated by Rood (1994) using a rigorous analysis of the mathematical physics; and laboratory measurements confirmed the presence of the mechanism (Gharib, 1994). The details of the three-dimensional flow as it evolves in time were investigated with numerical experiments, which proved to be the key to obtaining the needed quantification of the various dynamics underlying the event (Yue, 1995). Figure 7 is a computer-generated picture of one stage of the event. Because the computer computations have captured the quantitative information for all the variables, the computations can be used to obtain details important for assessing the role of various terms in turbulence models.

Breaking Spilling Wave

An example flow that must be modeled for computational ship hydrodynamics is the wake of the spilling breaking wave, such as the bow wave. A scenario for the model for the wake of the spilling breaking wave consists of several embedded numerical computations. Initially the RANS computation of the free-surface deformation indicates that the wave is building to a height indicative of incipient wave breaking (Paterson, Tahara, & Stern, 1995). A numerical simulation using exact physics is performed to determine the onset of wave breaking (Dommermuth & Mui, 1995). The breaking wave is then modeled as a mixing layer with vorticity flux emanating from the toe of the wave (Cointe & Tulin, 1994). The value for the vorticity flux is obtained from the local velocity upstream from

Figure 7.

Numerical Simulation of Vortex Loop Disconnecting to the Free Surface (Successive Time from Top to Bottom).

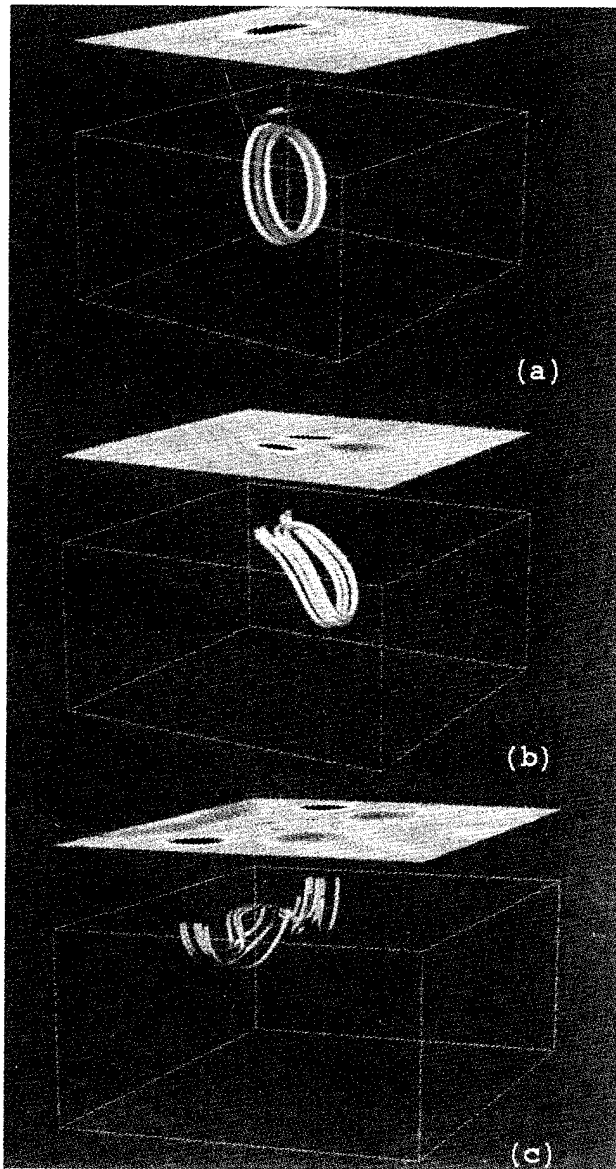

the wave as determined from the RANS computation of the three-dimensional nonbreaking wave (Rood, 1995). A large eddy simulation is employed to compute the roll up and production of the turbulent features of the mixing layer, which are then characterized as a turbulence spectrum. This turbulence spectrum is used to compute the Reynolds stresses, which are then inserted as a turbulence model in the RANS computations immediately downstream from the breaking

wave. The RANS computations then predict the evolution of the turbulent wake as it moves downstream from the wave.

The turbulence model for the breaking wave is a surrogate model that is obtained from embedded simulations within the RANS computation. The surrogate model links the information from the detailed physics obtained with the embedded simulation to the macroscale flow description (or effects) required to advance the hydrodynamic system computations. The embedded simulations are computationally burdensome, and in this scenario they are made only occasionally in time and locally in space as needed to obtain the coefficients required for the turbulence model for breaking wave.

The Future

The emergence of computational ship hydrodynamics is a beginning. It is the beginning of a major change in the way ships and submarines are designed, analyzed, and operated. The issue is how to manage and capitalize on this revolution to make it affordable. Intelligent and informed leadership is required to maintain a steady helm and an even keel along the path to simulation-based design, the ultimate goal.

Computational ship hydrodynamics is not inexpensive. A typical RANS computation for the flow around a surface combatant currently consumes some 70 CPU hours on a supercomputer. To be a useful engineering tool, computational ship hydrodynamics must suffer the processes of accreditation and certification. Naval hydrodynamicists must assume that computer hardware capability and algorithm development will pace each other to produce orders of magnitude more capability.

Is computational ship hydrodynamics more (or less) expensive than the cost for towing tank tests? This is like comparing apples and oranges; computations and measurements must be viewed as complementary tools with an overlap in which validation is obtained. In any case, towing tank measurements themselves will become more costly and sophisticated as such innovations as digital particle image velocimetry are employed to measure the time dependent flow of large eddies around ship hulls to develop higher performance ships. Computations cannot practically capture all the details of the flow, which contribute to the macroscale features such as the breaking wave and air entrainment. Measurements cannot capture all the parameterization available to computations, such as ranges of angle of incidence. Once the computation is established (converged and stable, and validated and calibrated), the geometry can be modified with ease to produce a range of information.

At the turn of the century, naval hydrodynamicists expect computational ship hydrodynamics to predict the hydrodynamic flow system, consisting of the hull, appendages, propeller for arbitrary ship orientation in a single frequency seaway. The computations will predict maneuvering and transient shal-

low water operations. Such a code will be a numerical unsteady Reynolds-Averaged Navier Stokes prediction method. The computer code will be validated but may require calibration against towing tank test, and will be used to extend the range of parameters and to scale results to full scale.

Biography

Dr. Edwin P. Rood graduated from Catholic University with a Doctorate of Philosophy in Mechanical Engineering (Fluid Mechanics). He is a program officer for the Office of Naval Research, and was previously a supervisory naval architect with the David Taylor Model Basin. He has been involved in naval hydrodynamics for over thirty years.

References

1. Bernal, L.P. & Kwon, J.T., "Vortex Ring Dynamics at a Free Surface," *Physics of Fluids A*, 1, 3, 1989, pp. 449-451.
2. Chen, B., Stern, F., and Kim, W.J., "Computation of Unsteady Viscous Marine Propulsor Blade and Wake Flow," *ONR Twentieth Symposium on Naval Hydrodynamics*, Santa Barbara, CA, 1994.
3. Cointe, R. & Tulin, M.P., "A Theory of Steady Breakers," *Journal of Fluid Mechanics*, 276, 1994, pp. 1-20.
4. Dommermuth, D.G. & Mui, R.C.Y., "The Vortical Structure of a Near-Breaking Gravity-Capillary Wave," *Journal of Fluids Engineering*, accepted and to appear, 1995.
5. Dommermuth, D.G., Novikov, E.A., & Mui, R.C.Y., "The Interaction of Surface Waves With Turbulence," *Free-Surface Turbulence*, ASME FED-Vol. 181, 1994, pp.123-139.
6. Farmer, J., Martinelli, L., & Jameson, A., "YACHT97: A Fully Viscous Nonlinear Free-Surface Analysis Tool for IAAC Yacht Design," *The Twelfth Chesapeake Sailing Yacht Symposium*, SNAME, 1995, pp. 157-170.
7. Gharib, M., "Some Aspects of Near-Surface Vortices," *Applied Mechanics Reviews*, 47, 6, Pt. 2, Jun 1994, pp. S157-S162.
8. Kerwin, J.E., Keenan, D.P., Black, S.D., and Diggs, J.G., "A Coupled Viscous/Potential Flow Design Method for Wake-Adapted, Multi-Stage, Ducted Propulsors Using Generalized Geometry," Annual Meeting of the Society of Naval Architects and Marine Engineers, Nov 1994, Paper No. 2.
9. Lekoudis, S.G., "Computational Fluid Dynamics - Navy Perspective," *11th CFD Conference*, AIAA-93-3294, 1993.
10. Lekoudis, S.G., "this issue"
11. Lugt, H.J., *Vortex Flow in Nature and Technology*, John Wiley & Sons, New York, 1983, pp. 10-13.
12. Mangiavacchi, N., Gundlapalli, R., & Akhavan, R., "Dynamics of a Turbulent Jet Interacting With a Free Surface," *Free-Surface Turbulence*, ASME FED-Vol. 181, 1994, pp. 69-82.
13. Paterson, E.G., Tahara, Y., and Stern, F., "Shipflow-Iowa: Computational Fluid Dynamics Method for Surface-Ship Boundary Layers and Wakes and Wave Fields," in preparation, Iowa Institute of Hydraulic Research, The University of Iowa, Iowa City, IIHR Report, 1995.
14. Purtell, L.P., "Turbulence: A Roadblock to CFD", this issue
15. Rood, E.P., "Interpreting Vortex Interactions With a Free Surface," *Journal of Fluids Engineering*, 116, 1, 1994, pp. 91-94.
16. Rood, E.P., "Origins of Vorticity on the Free-Surface Boundary of a Viscous Irrotational Flow", *Symposium on Interaction of Surface Waves, Currents, Bodies and Wakes at or Near a Free Surface Phenomena*, ASME AMD Volume, 1995.
17. Sclavounos, P. D., Nakos, D.E., & Huang, Y.-F., "Seakeeping and Wave Induced Loads on Ships with Flare by a Rankine Panel Method", *Proc. 6th Int. Conf. Numerical Ship Hydrodynamics*, National Academy Press, 1994, pp. 57-77.
18. Stern, et al. for the FF1052
19. Stern, F., Kim, H.T., Zhang, D.H., Toda, Y., Kerwin, J., & Jessup, S., "Computation of Viscous Flow Around Propeller-Body Configurations: Series 60 CB= 0.6 Ship Model," *Journal of Ship Research*, 38, No. 2, Jun 1994, pp. 137-157.
20. Stern, F., Zhang, D., Chen, B., Kim, H. & Jessup, S., "Computation of Viscous Marine Propulsor Blade and Wake Flow," *ONR 20th Symposium on Naval Hydrodynamics*, Santa Barbara, CA, 1994.
21. Sung, C.H. & Huang, T.T., "Recent Progress in Incompressible Reynolds-Averaged Navier-Stokes Solvers," *Proceedings of International Conference on Hydrodynamics*, 1994, pp. 492-506.
22. Weems, K., Korpus, R., Lin, W.-M., & Fritts, M., "Near-Field Flow Predictions for Ship Design," *Proceedings of Twentieth Symposium on Naval Hydrodynamics*, Aug 1994.
23. Whitfield, D.L., "Perspective on Applied CFD," *33rd Aerospace Sciences Meeting and Exhibit*, AIAA-95-0349, 1995a.
24. Whitfield, D.L., private communication to be published, 1995b.
25. Yue, D.K.P., private communication to be published, 1995.

Profiles in Science

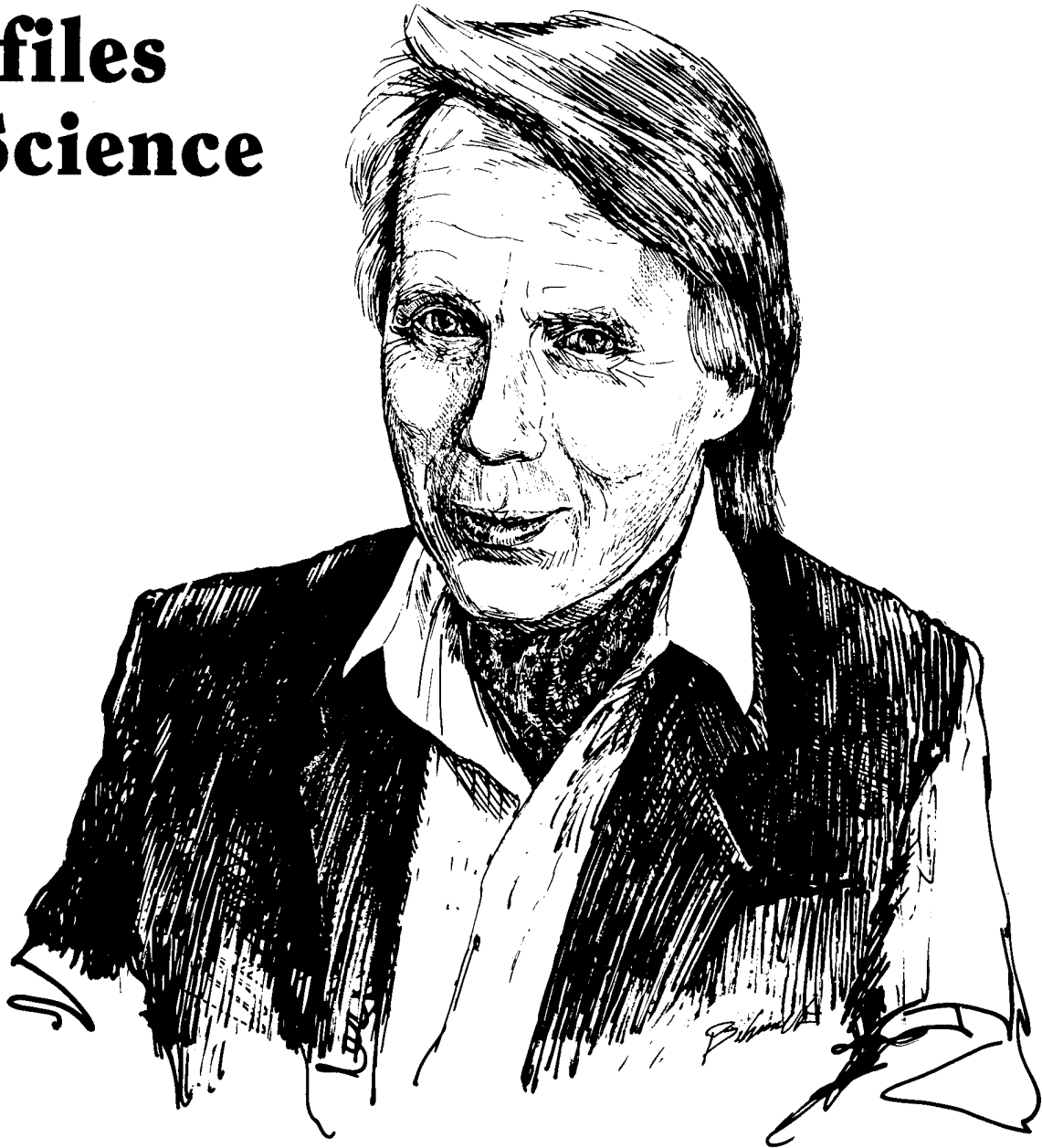

Antony Jameson

Antony Jameson is the James S. McDonnell Distinguished University Professor of Mechanical and Aerospace Engineering at Princeton and for many years has been a principal investigator of the Mechanics Division of the Office of Naval Research.

After graduating from Cambridge University, England, he remained to get a Ph.D. in magnetohydrodynamics and continued as a Research Fellow of Trinity Hall. He came to the U.S. in 1966 to work for Grumman Aerospace Corporation

where his research was directed toward the application of automatic control theory to stability augmentation systems and the problem of predicting transonic flow.

The computational fluid dynamic algorithms and software that he created have been used to design several commercial and military airplanes, including the F-22 and modifications to the Navy's F-14. For the past several years, Professor Jameson has been successfully employing optimal control theory to the design problem in fluid dynamics.

Turbulence: A Roadblock to Computational Fluid Dynamics

L. Patrick Purtell
Office of Naval Research

Abstract

Continuing, indeed accelerated, advances in computational fluid dynamics (CFD) are required to meet the challenges of simulation-based analysis and design of naval hydrodynamics systems. The great progress achieved in the power of computers and in numerics applicable to the equations of fluid mechanics exposes the critical need for adequate representations of turbulence. An existing extensive hierarchy of turbulence models must be evaluated, and new, more sophisticated models need to be developed for the truly complex flow fields of practical interest.

Introduction

Richard Feynman is said to have remarked, "Turbulence is the last great unsolved problem of classical physics." Despite decades of extensive, dedicated, innovative, even ingenious attempts to derive a "theory of turbulence" which can predict its statistical characteristics (eg., average fluctuation levels), turbulence as a whole remains beyond our analytical capability. Nevertheless there is a very practical need to predict turbulent flowfields in remarkably diverse conditions: around ships and aircraft, in pipes and ducts, in chemical mixers and combustors, and in the atmosphere and ocean.

This need to provide solutions to pressing technical problems led to the development over many years of numerous simple correlations and approximate ad hoc methods in fluid mechanics. However, the explosive growth in computer power

and associated numerical techniques in the last few decades has correspondingly reduced the need for such methods. The ability to calculate discretized versions of the equations of fluid mechanics has evolved rapidly and has been limited primarily by computer power. The representation of turbulence in these codes, however, has not kept pace, though significant advances have been made. As computer power increases and numerical methods are improved, the limitations to accuracy caused by inadequate turbulence models become more and more apparent.

A brief summary of the fundamentals underlying contemporary turbulence models is in order here. The Navier-Stokes Equations (NSE), the fundamental equations of viscous flow relate changes in momentum to forces

$$\frac{\partial u_i}{\partial t} + u_j \frac{\partial u_i}{\partial x_j} = \frac{1}{\rho} \frac{\partial \sigma'_{ij}}{\partial x_j}$$

where u_i is the velocity and σ_{ij} is the stress tensor. Two characteristics of the NSE in particular should be noted: first, the nonlinearity of the second, "convective", term (the source of "richness" for the physicist and of "problems" for the engineer!) and second, the requirement that at a solid boundary the fluid velocity equals the velocity of the boundary (eg., zero for a stationary boundary). For flows of low momentum and high viscosity (ie., flows of low Reynolds number, the ratio of momentum to viscous resistance), the flow will be smooth and generally predictable, even in unsteady conditions. Numerous analytical solutions to the NSE

have been derived for such conditions, and today computational techniques render such flows effectively solved. However, such flows are rare in practice, and at realistic Reynolds numbers, the flow is unstable and becomes turbulent through a variety of dynamical processes (the study of which, "stability and transition", is a field of its own).

Turbulence has numerous intriguing characteristics which would require volumes to describe in detail. For present purposes it will suffice to summarize only a few of them. First, *turbulence has not been found to disobey the NSE* at any point or time in the flow. This is crucial, of course, since otherwise we would need to rederive the fundamental equations of motion. Second, turbulence involves fluctuations over a *wide range of length and time scales*, a range which increases with the Reynolds number. The largest fluctuation, or "eddy", is of the order of the size of the flow, such as the width of a wake or the diameter of a pipe. The smallest scale is limited by viscous dissipation, but it is typically orders of magnitude smaller than the largest scales.

Third, *the eddies are strongly affected by the average motion* and likewise affect the average motion. They are not merely "swept along" with the flow. It should be noted, though, that turbulent flow is, on average, "similar to" laminar flow; it is not radically different in overall character (eg., a wake is still a wake). This is critical for computational approaches. Fourth, and finally, *turbulence is important*. It cannot be ignored, and it cannot often be replaced by simple approximations.

Representations of Turbulence

Observation of eddies and thus a perception of turbulence long predates the modern development of fluid mechanics, so it is no surprise that attempts to account for turbulence analytically nearly coexisted with the development of the NSE themselves. The gross "similarity" of turbulent flows to laminar flows mentioned before soon prompted the concept of an "eddy viscosity" analogous to the molecular viscosity. Thus the expression for the shear stress in unidirectional laminar flow, σ'_{12} , which is proportional to the rate of strain (ν is the kinematic viscosity and ρ is the density):

$$\sigma'_{12} = \rho \nu \frac{\partial u'_1}{\partial x_2}$$

is replaced by

$$\overline{\sigma'_{12}} = \rho (\nu + \nu_t) \frac{\partial \overline{u'_1}}{\partial x_2}$$

where the overbar indicates a time-average (or ensemble average for unsteady flows), and an "eddy viscosity", ν_t , has been added to the molecular kinematic viscosity. Dimensionally, the eddy viscosity is a characteristic length (squared)

over a characteristic time. A straightforward use of a constant eddy viscosity would imply that the turbulence is a property of the *fluid*, whereas it is a strong property of the *flow*, varying widely throughout a typical flowfield. Simple expressions for the eddy viscosity are at the foundation of many turbulence models, but work only in flows for which they are tightly calibrated and in conditions where the turbulence is in approximate equilibrium with the mean flow, eg., in far wakes or jets. It has been pointed out² that "... eddy viscosity concepts underlie the entire range of models for turbulence..." from representing all of the turbulence (simple models) to representing specific quantities (such as terms in higher order transport models). The latter are really generalized eddy viscosities which may vary in space and time.

There are several broad categories of theoretical approaches to turbulence, eg., statistical theories utilizing the extensive body of mathematics developed for statistical mechanics, wave (Fourier) descriptions concerned in particular with energy flow among scales of motion, and more recently dynamical systems theory (chaos). These will not be discussed here where the focus is on the more utilitarian aspects of modeling and its use in computational fluid dynamics (CFD). However, advances in fundamentals of modeling are likely to depend more and more on sound theoretical concepts. Rational approaches utilizing renormalization group theory or rapid distortion theory are more frequently found in the literature today underlying important advances in sophisticated models.

Osborne Reynolds³ introduced a concept which today forms the basis of the representation of turbulence in most of computational fluid dynamics (CFD). He decomposed the velocity into a time- (or ensemble-) averaged part, U_i , and a fluctuating part, u_i ,

$$u'_i = U_i + u_i$$

He then introduced this decomposition into the equations of motion, averaged the equations over time (or ensembles), and produced what today are named the Reynolds-Averaged Navier-Stokes (RANS) equations. The nonlinearity of the convective terms produces an average (or correlation) of the product of the fluctuating components termed the "Reynolds stress", $\overline{u_i u_j}$

$$u'_j \frac{\partial u'_i}{\partial x_j} \rightarrow U_j \frac{\partial U_i}{\partial x_j} + \frac{\partial \overline{u_i u_j}}{\partial x_j}$$

where $\overline{u_i u_j}$ is frequently denoted by τ_{ij} . The eddy viscosity concept then has τ_{ij} set proportional to the average rate-of-strain.

Simple expressions of this concept wherein the eddy viscosity is determined by algebraic expressions are termed "zero-equation" models since no auxiliary differential equation must be solved. The more developed examples of these, eg. Cebeci-Smith and Baldwin-Lomax models, are popular for

boundary layers because of their simplicity and low demands on computer resources. They are, however, inaccurate for complex flows and require "calibration" for the particular type of flow encountered.

Instead of employing algebraic expressions for the characteristic length and velocity (and thus the eddy viscosity), "moments" of the NSE may be derived. The NSE may be considered as "transport equations" for the momentum. If they are multiplied by velocity and then averaged, a transport equation for kinetic energy may be derived, and in a similar manner transport equations for other quantities may be developed.

This approach demands some further discussion. The higher moment equations are derived completely from the NSE and thus contain *no additional information* about the flowfield! It is merely hoped that by modeling terms in the higher order equations instead of in the first order we may incorporate more complex physics in the flow. This can indeed be convincingly argued, but proper models for some of the complicated higher order terms are so difficult to construct and evaluate that the cumulative errors may overwhelm the advantages of more physics.

Models which utilize a transport equation for the turbulent kinetic energy alone are the "one-equation" models in which the eddy viscosity is written:

$$\nu_t = K^{1/2} l_o$$

where l_o is a length characteristic of the turbulent eddies and K is the turbulent kinetic energy. Since we must still devise a method for specifying l_o , these models are considered by some to be not much of an improvement over the zero-equation models. (There are exceptions for specific cases, and they are still much simpler to incorporate in numerical codes than the second moment classes of models.)

If a second transport equation is written for a quantity which determines l_o , typically ϵ , the viscous dissipation of turbulence, then we have the "two-equation" class of models. These models are considered the simplest "complete" models in that both the characteristic length and the characteristic velocity are determined from PDE's and not ad hoc functions. Sophisticated extensions to include anisotropic eddy viscosities or other complexities are still being investigated.

An alternative to an eddy viscosity formulation involves writing a transport equation for τ_{ij} itself. The resulting "second moment" equations, or "second order closure" (SOC), for the Reynolds stress components comprise the most complex representation of turbulence which can be modeled for practical purposes. Because of the nonlinearity of the NSE, however, third order terms appear in these equations which must be modeled. Higher order equations would likewise contain even higher order terms; this is referred to as the "closure" problem in turbulence.

Variations on the standard RANS theme arise from time to time which have intriguing characteristics. One such approach which gets occasional mention is sometimes termed the "split-spectrum method".⁴ This technique, and others similar to it, prescribe multiple time or length scales (not just the single scales of standard RANS). Because of increased complexity and added difficulty of calibrating such models, they have not been extensively pursued. However, the availability of direct simulation data today and the realization that more sophisticated models will be needed for complex flows may bring a revival of these and other approaches.

Though the focus here is on turbulence modeling as related to CFD, an important topic which has the potential to describe some problems not addressable by RANS deserves mention. Large-eddy simulation⁵, wherein the smaller scales of turbulence are modeled and the larger scales are directly computed, is a topic of intense development. It is intermediate between direct numerical simulation (DNS) of the NSE with its tremendous demand on computer resources and RANS which describes turbulence only at one point. One particular need in naval applications is the ability to compute spatial correlations of pressure fluctuations on surfaces for acoustic source predictions. Models for the small (subgrid) scales are developed utilizing the same theories underlying RANS development, but the hope is that these small scales are much more universal in nature than turbulence as a whole and thus capable of description over a wide range of flow conditions.

This concludes a very brief and coarse-grained summary of turbulence modeling as pursued today. The models are numerous and vary in level of complexity, details of calibration, and numerical implementation. Their performance likewise varies on a wide range of flow configurations which have been addressed.

CFD: Equations, Numerics, and Grids

Computational Fluid Dynamics (CFD) is the prediction of fluid flow by numerical solution of equations of motion. Equations are selected, discretizations and numerical procedures are chosen, and the geometry of the flowfield specified. All of these are important and difficult steps in constructing a numerical model of the flow under consideration. However, several decades of intensive study have raised many aspects of the art to a science so that today CFD is routinely used in the design process of many fluid flow systems.

Only fairly recently has computer power become so available and inexpensive that solution of the full NSE have been utilized for design purposes. For large and complex systems where viscous effects may be (or at least are *declared* to be) unimportant or accounted for in other ways, inviscid methods are utilized. These may be derived in terms of a velocity potential ("potential" methods) or by setting the viscosity to zero in the NSE ("Euler" methods).

Appropriate numerical techniques and corresponding grids are then selected for the computations. The importance, and difficulty, of these two steps should not be underestimated. However, there have been tremendous advances in these areas, both in reducing required computer resources and in improving accuracy. Thus difficulties in turbulence modeling when using a Navier-Stokes code become more apparent and more important to further improvements.

Performance

One difficulty in evaluating a turbulence model is the separation of errors due to the model from errors due to other sources such as the numerics, the grid resolution, and perhaps the most difficult, the interaction of the model with these others. However, techniques for estimating numerical error by analysis and for determining grid problems by grid refinement studies can in general isolate sources of problems. One other problem which must be considered, though, is that of error in *experimental data* used for comparison with calculations. Here, too, there are techniques for error analysis if they are employed properly.

Prediction of viscous flow around surface ships has received more attention recently than in the past and has brought to light the difficulties in the computation of this highly complex, vortical, high Reynolds number flow. One effort⁶ which included the needed examination of error sources concluded, "Grid refinement in the near wake or application of new accurate discretization schemes have ... little effect on the quality of the solution in the wake." For their particular turbulence models, a zero-equation model and several two-equation $k-\epsilon$ models, the authors concluded that the errors were caused by "... too high levels of turbulence viscosity." They provided further evidence of this by arbitrarily decreasing the eddy viscosity in the critical hull vortex region and got much better agreement with experimental data. (See also the companion article in this volume, "The Emergence of Computational Ship Hydrodynamics")

The design of aircraft has long been a driver for advances in CFD. Here, as in any engineering environment, "...different accuracy demands (in design work) lead to different accuracy demands on the design tools."⁷ The authors of that review paper also concluded that turbulence models were critical to meeting design requirements: "In general weakly interacting flows can be predicted well... [but] ... strongly interacting flows of all kinds... often cannot be predicted well." In particular they propose focusing turbulence modeling on complex flows exemplified by three-dimensional separation.

Some flows are more strongly influenced by turbulence than others. A recent study of flow over a wing-body configuration⁸ found that for various low-order turbulence models, "...the wing pressure distribution is predicted very well [at zero lift]...". However, the drag coefficient was overpredicted by

Figure 1.

Computed and experimental pressures at 30° angle of attack.

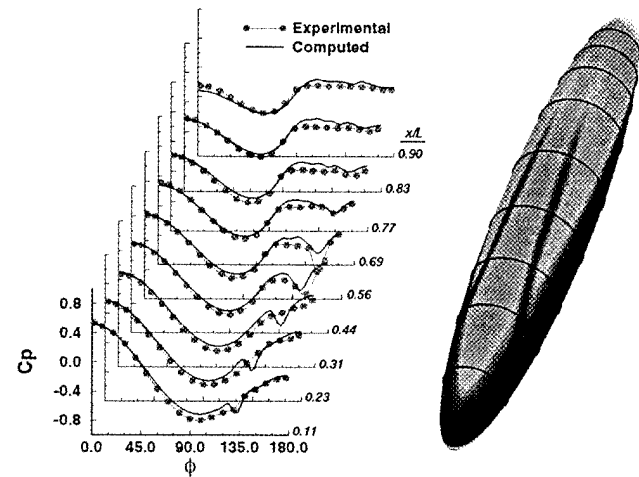

nearly 30%. Also, the lift coefficient was predicted only to within 5% for a 3 degree angle of attack. For some requirements, eg., maneuvering, normal forces (such as lift) may be of primary concern and errors in drag can be ignored, but in other cases (such as in commercial aircraft) an accurate prediction of drag is of paramount concern.

One important aspect of the flows around naval surface ships and submarines is the extensive regions of highly three-dimensional flow and especially three-dimensional separations. These 3-D separations are gradual developments of shear layers which lift off from the surface and wrap into sheets of vorticity. They are sensitive to surface (skin) friction and thus to turbulence in the boundary layer. Predictions are both important and difficult. An example which shows both the advances which have been made in the state of the art and the need for further developments is shown in Fig. 1⁹. The important qualitative features of the separations have been captured, and even the quantitative agreement is impressive over much of the body, but the pressures on the important regions near the stern and near the vortex sheets require further developments. The authors point in particular to the need for further work in the turbulence modeling.

Other requirements may demand accurate prediction of flow *details* such as the junction vortices around control surfaces or vanes in a compressor. Some recent work on tip vortex flow concluded that a specialized one-equation turbulence model worked well for the velocity distributions, which are of primary importance for aircraft applications. However, the *pressure* in the vortex core was severely underpredicted (25%) which would have a major impact on cavitation prediction for naval applications. The authors argue that the error results

from "...a poor representation of the normal Reynolds stresses typical of one-equation turbulence models."

Most of the examples mentioned so far have utilized simple, zero- or one-equation models for the turbulence which we know require ad hoc specification of at least one characteristic scale. Two equation models, the minimum in complexity which do not require ad hoc specification of turbulence scales at the most basic level, require a significant increase in computer resources and care with numerical stability and accuracy. Their inherent capabilities, however, should justify their use in practical problems containing significant flow complexity. Even here, though, care must be taken to include sufficient capability demanded by the problem to be addressed. Fig. 2. compares the development of turbulent kinetic energy in homogeneous turbulence subject to suddenly imposed homogeneous shear at time zero. Standard models, including standard two-equation models, are far from adequate in predicting this flow. A two-equation model which includes a special modification based on a perturbation analysis is required to capture the development of the flow. It should be noted that the models are evaluated against a *direct numerical simulation* of the flow. Such comparisons are now much more commonplace and provide needed details for model evaluation.

"Standard" two-equation models which do not incorporate strain-dependent coefficients cannot, even in principle, predict the effects of streamline curvature, system rotation, or secondary flows arising from normal Reynolds stress anisotropies. In the past these deficiencies were overcome by ad hoc modifications, but today more sophisticated, but still two-equation, models are being developed to address these problems. One difficulty, however, is that this extensive research "...has led to large numbers of specialized CFD codes limited to specific problems" and thus "...seriously impede the acceptance of CFD in the design community."¹²

Do even more complicated models (second order closures) perform better still? Here at best we find confusion. A recent study¹³ compared an advanced two-equation model with a standard full second order closure (SOC) for a rather simple but challenging two-dimensional diffuser with flow separation at the wall. The two-equation model performed well, but the more complex model failed to predict even the *occurrence* of separation! However, the state of two-equation modeling is still confusing for application purposes; recently an engineering manager of a major aerospace firm stated that they have for the present completely "abandoned" two-equation models for lack of confidence in them.

Considering the hesitation to embrace even two-equation models, full SOC is clearly merely a research topic at this point. The state of the art in this area has been summarized thus:¹⁴ "...existing SOC's are not capable of describing flows that are far from equilibrium and have major problems with wall-bounded flows." The latter point concerning wall-

bounded flows deserves further discussion because of its importance. It has been stated¹⁵ that the "Achilles heel of second-order closures is wall-bounded turbulent flows." The reasons are rather arcane, but they necessitate in many cases specifying ad hoc models of higher order terms near walls which depend on the distance from the wall – a difficulty in complex geometries. The author concludes, "Entirely new non-equilibrium models are needed..." for the terms causing the difficulties. It is further pointed out, though, that a SOC, not a two-equation model, *will be needed* for problems which include relaxation or extensive nonlocal effects.

Future Directions

The two opposing desires – CFD codes which are more accurate and general, and CFD codes which are faster and cheaper – will continue to define the directions of development in numerics, gridding, and turbulence modeling. For example, in numerics a tradeoff may be between a higher order method and a faster code requiring less memory. In gridding the simplicity of structured and fixed grids may compete with the generality and potential overall accuracy of unstructured and adaptive grids.

Figure 2.

Evolution of kinetic energy in homogeneous turbulence subjected to uniform shear at $t^0 = 0$.

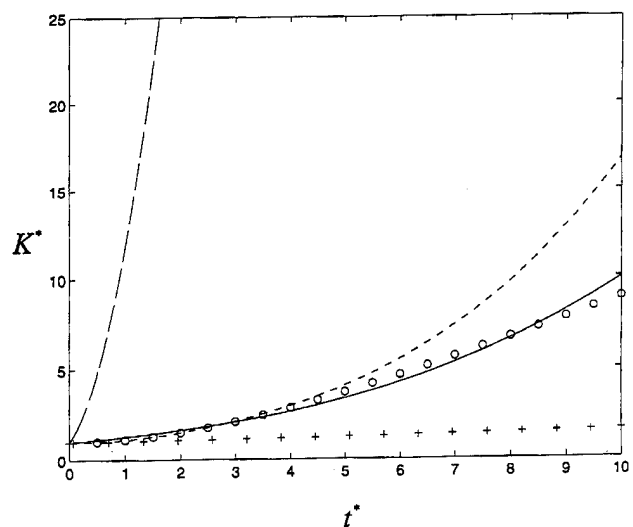

In turbulence modeling the tradeoffs themselves are not yet well-defined. It is generally agreed that higher order models should permit inclusion of more physics in the computations. But the performance today of the most sophisticated models is mixed at best. The simpler models have been shown repeatedly to be applicable only to limited types of flow and not accurate enough even then for many requirements.

Developments continue to occur, however, and there is some hope in recently proposed models at the intermediate, two-equation level. The newer models¹⁶ are formally derivable from full SOCs and contain increased generality via strain-dependent terms and coefficients to overcome some deficiencies in earlier models. However, they are still strictly applicable only to turbulence which is locally homogeneous and in equilibrium, or very nearly so.

An alternative, or perhaps parallel, approach is a cataloging of existing lower order models and the applications for which they have been validated. This is at best a temporary measure unless the concept of "zonal" modeling is developed, wherein turbulence models are selected dynamically depending on the type of flow encountered. In the near term categories of models selected for specific design problems may be useful, but significant design efforts usually involve new configurations significantly different from previous ones which thus preclude this approach.

In the intermediate and far term the significant advantages of full SOC still appear promising. There are definite problems to be overcome, but formal approximation techniques continue to be developed and applied for generating appropriate models of higher order quantities. Among the many benefits of the development of direct numerical simulation of turbulence (DNS) over the past dozen years or so is the ability to examine turbulence quantities that have been impossible to measure. Such simulations have led to important developments in modeling the higher order terms in the SOCs. If the critical problem of calculating near a wall is solved, the SOC will become impossible to ignore, even though a major computer resource cost penalty may be incurred.

The proper representation of turbulence is indeed a significant roadblock to the ultimate promises of CFD. However, advances on many fronts – from cataloged, validated lower order models to rationally constructed two-equation models to advances in full second order closures – indicate important new capabilities ahead for the many areas of engineering design involving the flow of fluids. The history of progress in this area is a prime example of researchers, developers, and designers interacting, though not without a struggle, to realize the promises of CFD.

Biography

Dr. L. Patrick Purtell graduated from the University of Maryland with a Doctorate of Philosophy in Mechanical Engineering. He is a Program Officer for the Office of Naval Research and previously held positions at the David Taylor Model Basin and at the National Institute of Standards and Technology.

References

1. Rouse, H.; Ince, S., *History of Hydraulics*, Iowa Institute of Hydraulic Research, 1957.
2. Frisch, U. & Orszag, S.A., *Physics Today* P. 24, January, 1990.
3. Reynolds, O., *Phil. Trans. Royal Soc. London, Series A. Vol. 186*, 1895.
4. Hanjalic, K., *Int. J. Heat and Fluid Flow*, vol. 15, no. 3, June, 1994.
5. Ghosal, S., & Moin, P., *J. comp. Phys.*, vol. 118, 1995.
6. Deng, G.B.; Queutey, P.; Visonneau, M., *Proc. Numerical Ship Hydrodynamics*, 1993.
7. Hirschel, E.H.; Stock, H.W.; Cousteix, J., *Proc. 2nd Intl. Symp. Engr. Turb. Modeling and Measurements*, W. Rodi & F. Martelli editors, Elsevier Science Publ., 1993.
8. Marconi, F.; Sislari M.; Carpenter, G.; Chow, R., *AIAA-94-2237*, 1994.
9. Taylor, L.K.; Arabshahi, A.; Whitfield, D.L., *AIAA-95-0313*, 1995.
10. Dacles- Mariani, J.; Zilliac, G.G.; Chow, J.S.; Bradshaw, P., to be published, 1995.
11. Speziale, C. & Xu, X.-H., *Towards the Development of Second-order Closure Models for Non-equilibrium Turbulent Flows*, to be presented at the Tenth Symp. on Turb. Shear Flows, University Park, PA, Aug., 1995.
12. Melnik, R.E.; Siclari, M.J.; Barber, T.; Verhoff, A., *AIAA-94-2235*, 1994.
13. Durbin, P.A., *Center for Turb. Res. Manuscript 152*, Stanford Univ., 1994.
14. Speziale, C.G., "Modeling of Turbulent Transport Equations", to be published, 1995.
15. *Ibid.*
16. Speziale, C.G., *Proc. 20th Symp. Naval Hydrodynamics*, Natl. Acad. Press, to be published, 1995.

Computational Analysis of a Missile at a High Angle of Attack

*Robert Van Dyken
Naval Air Warfare Center Weapons Division
China Lake, California*

Introduction

Air-to-air missiles currently deployed in the fleet are not designed for high angle of attack launches from maneuvering aircraft. The missile airframes are aerodynamically stable and “tip-off” or “weather-cock” into the free stream when launched at angles of attack greater than 30 degrees. Survival in air combat depends in part on the design of agile missile airframes. Airframe control must be maintained even in very high angle of attack situation— aerodynamic conditions well beyond current design code capabilities.

In the past, missiles were designed with the use of empirical databases, flight test data, wind tunnel testing, engineering judgment, and computer codes based on panel methods with capabilities restricted to moderate angles of attack. Recent advances in numerical analysis methods and advanced computing power allow solutions of three-dimensional flowfields with better models for the physics of the flow. Detailed flow-field analysis is provided by computational fluid dynamics (CFD) methods which can predict vortex flow development, vortex bursting, and flow asymmetries for high angle of attack flight performance. However, these CFD codes must be validated by comparing the CFD results with extensive and detailed experimental data including flowfield information, in addition to the usual surface and integrated forces and moment measurements.

At the higher angles of attack, which occur at subsonic speeds, the flowfield is complex and dominated by strong

vortices. Viscous effects significantly affect the growth and dissipation of separated and rotational flows, requiring the use of Navier-Stokes equations to accurately predict missile performance. CFD methods using the Navier-Stokes equations represent the most concise formulation of the conservation laws with all the relevant physics to predict the performance of missile airframes at high angles of attack. The analysis method also gives a better understanding of the stability and control required in a missile to safely and successfully deploy it from aircraft with supermaneuvering capabilities, up to 70-degree angles of attack.

The Navy has long since been interested in resolving the high angle of attack problem; thus, work that focuses on predicting steady and unsteady, post-stall performance of marginally stable missile airframes, operating at both high angles of attack and at high acceleration levels, has begun.

An Analytical Approach to the High Angle of Attack Problem

For the steady angle of attack results described herein, the OVERFLOW code developed at NASA-Ames is used for the numerical simulation. In this code, the overset Chimera technique is implemented. The vortical flows are computed by using the Baldwin-Lomax eddy viscosity model with the modifications suggested by Degani and Schiff.¹

The complex surface geometry is subdivided into simpler components. The numerical mesh for the components such as

Figure 1.

Grid Partition for the Complete Missile Configuration.

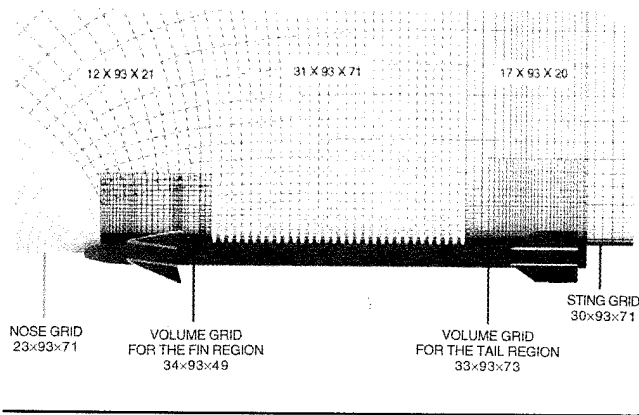
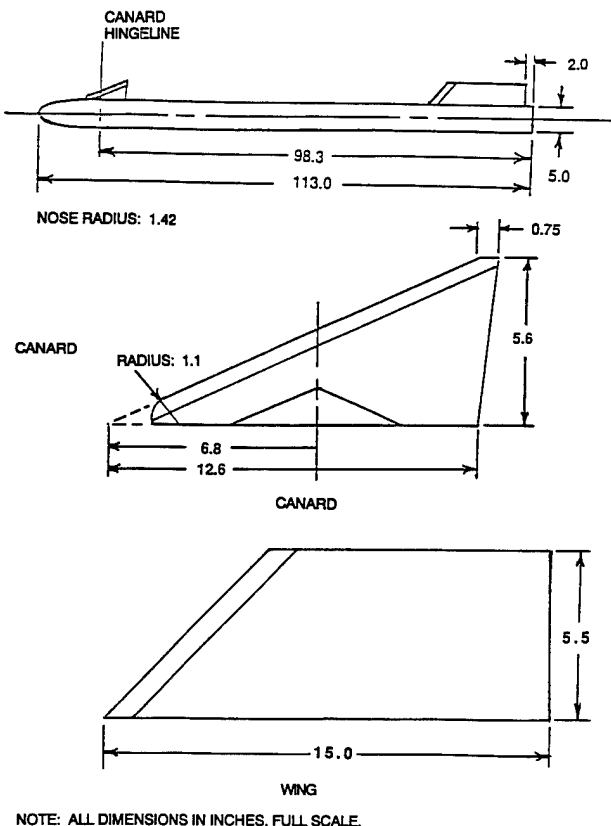

Figure 2.

Missile Configuration With Full Wings.



fins, tails, and the missile body are generated first, then brought together to form a unit. Partitioning helps reduce the in-core memory requirements and allows local grid refinement in selected flow regions. The grid partitioning for a complete missile configuration is shown in Figure 1.

The PEGSUS code was used to preprocess the grid data, providing interpolation stencils at the grid interfaces and defining regions where holes are cut by one grid into another. The overset method provides flexibility in decomposing the computational domain and facilitates the grid generation over complex geometries, as well as small modifications to the original configuration. Symmetric solutions for a half body were obtained, using reflection at the symmetry plane.

The code uses the thin-layer compressible Navier-Stokes equations to obtain the numerical solutions. The strong conservation law form of the governing equations for a curvilinear coordinate system (ξ, η, ζ) along the axial, circumferential, and normal direction, respectively, is as follows:

$$\partial_t \widehat{Q} + \partial_\xi \widehat{F} + \partial_\eta \widehat{G} + \partial_\zeta \widehat{H} = \text{Re}^{-1} \partial_\zeta \widehat{S} \quad (1)$$

The numerical integration is performed using a partially flux-split numerical scheme. A two-factor scheme is selected which uses Steger-Warming flux vector splitting for the stream direction and central differences for the other two directions. For the central differencing directions, implicit and explicit smoothing are used. The resulting two-factored algorithm is

$$\begin{aligned} & [I + h\delta_\xi^b (A^+)^n + h\delta_\zeta C^n - h\text{Re}^{-1} \delta_\zeta J^{-1} M^n J - D_{i\zeta}] \\ & \times [I + h\delta_\xi^f (A^-)^n + h\delta_\eta B^n - D_{i\eta}] \Delta q^n \\ & = -\Delta t \{ \delta_\xi^b [F^+]^n - F_\infty^n \} + \delta_\xi^f [F^-]^n - F_\infty^n \\ & \quad + \delta_\eta (G^n - G_\infty) + \delta_\zeta (H^n - H_\infty) \\ & \quad + \text{Re}^{-1} \delta_\zeta (S^n - S_\infty) \} + D_e (q^n - q_\infty) \quad (2) \end{aligned}$$

In Eq. (2), D_e are the explicit dissipation terms that are used along the directions where central differencing is employed, and D_i are the implicit dissipation terms that are added for numerical stability. The dissipation terms used are a combination of second- and fourth-order terms.¹

Steady CFD Results for an Advanced Configuration

Using the analytical approach described above, the missile flowfield for an advanced missile configuration was computed for 45-degree roll, which is the preferred orientation during flight requiring maneuvers to the target.² The missile configuration considered is shown in Figure 2. Solutions were

Figure 3.

Missile Forebody and Fin Gap Grids.

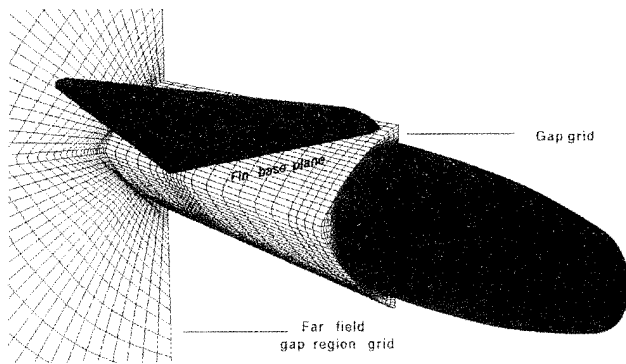

obtained for a free-stream Mach number of 0.3, angles of attack up to 60 degrees, and a Reynolds number of 1 million, which is typical of a high angle of attack launching scenario. Flowfield solutions were computed with the fins off and on. The gap between the body and fin was also modeled, as shown in Figure 3. The Reynolds number, based on the missile diameter, was high enough to assume fully turbulent flow which was used in the analysis.

Shaded contours of Mach numbers are shown in Figure 4 at a crossflow plane aft of the forward canards. The flow is coming from the lower right to upper left in the figure, with the missile body at a 45-degree angle of attack and both canards deflected an additional 10 degrees. The darker blue regions above the missile body are the result of flow separation over the upper and lower canards. However, where the fins do not influence the flow on the windward side of the body, an accelerated flow region is shown in red. The characteristics of shear flow are shown in the small area between the two flow regions.

For the same flow conditions, the vortex system with helicity (measure of the vortex strength) densities at several crossflow planes is shown in Figure 5. Flow over the fins was shown to be highly separated with no coherent leading edge vortex. The forebody vortex, as well as the vortices generated in the gap between the fins and the body, is complicated, merging into a single vortical flowfield region over the upper fin. Downstream of the canards, vortices are generated by the missile body which did not lift away from the missile surface, but, rather, merged with the tail vortical flowfield.

Normal force and pitching moment coefficients for experimental data, computations, and Missile DATCOM (Data Compendium Air Force generated aerodynamic database) are shown in Figure 6 for the missile in the "x" orientation with canard fins deflected 10 degrees. For this case, the 1993 Missile DATCOM database gives good results; however, no

Figure 4.

Mach Number Contours in Crossflow Plane Aft of Canards.
 $M_\infty = 0.3, \alpha = 45^\circ, \phi = 45^\circ, \delta_{can} = 10^\circ, Re_D = .95 \times 10^6$.

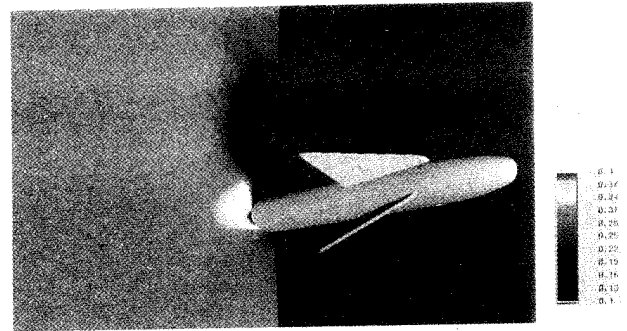

knowledge is gained about the details of the flowfield to assist in making rapid design improvements.

The computed flowfield over the missile indicates that the complex flow pattern generated by the deflected fins plays an important role in the development of the vortical flowfield over a missile at high angles of attack. In the future, complete body modeling may be required because of the asymmetric vortices that are known to be generated by long slender bodies at higher angles of attack to get better agreement with experimental data.

For the missile in the "+" orientation with zero canard fin deflection, shown in Figure 7, computations executed with the General Aerodynamic Simulation Program³ (GASP) give excellent agreement with experiments, while Missile DATCOM grossly underpredicts both the normal force and pitching moment coefficients.⁴ The details of GASP calculations are beyond the scope of this discussion, therefore are not included herein.

Unsteady CFD Results for Pitching Missile Body

A Navier-Stokes simulation of laminar, low subsonic flow over a pitching missile body was executed for incidence angles up to 25 degrees. The CFL3D⁵ code was used to obtain the numerical solutions. (Details on this code can be found in Reference 5). The flow was assumed to be symmetric with respect to the pitching plane throughout the calculations. Computed results of helicity at several crossflow planes along the body are given for a missile body pitching at a high rate of 500 deg/s.⁶

Figure 8 gives the computed helicity for a missile body alone at the peak angle in the oscillation cycle shown in the shape of a horseshoe around the body. A prominent vortical

Figure 5.

Vortical Flow Field over the Missile Shown by Helicity.
 $M_\infty = 0.3, \alpha = 45^\circ, \phi = 45^\circ, \delta_{can} = 10^\circ, Re_D = .95 \times 10^6$.

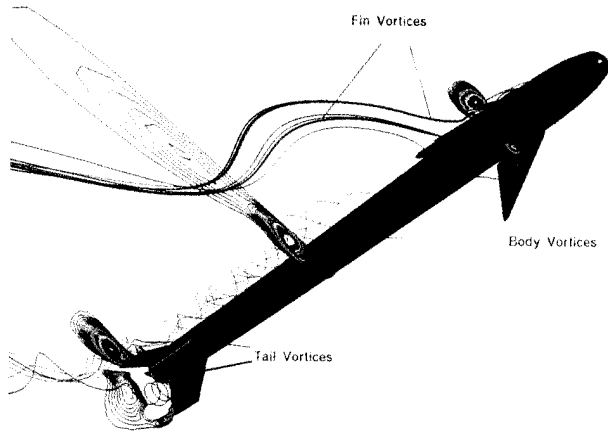

flow structure is shown at a 25-degree angle of attack with vortices beginning to spread away from the body because the pitch rate has decreased to 0 deg/s at the top of the oscillation cycle.

The computations clearly show the vortex lag effects during the oscillation cycle, as shown in Figures 9 and 10, where the vortex strengths are larger on the downstroke when compared with those at the same angle of attack on the upstroke. However, the missile body produces more lift on the upstroke at 15 degrees when the vortices are tightly concentrated around the leeward side of the body, as opposed to the large circular and spread vortical flow patterns for 15 degrees on the downstroke, as shown in Figure 9. Only the start of vortical flow development at the last crossflow location is shown in Figure 10 at a 5-degree angle of attack on the upstroke, but vortical flow still exists at all crossflow locations for 5-degree angle of attack on the downstroke.

An extension of the unsteady-body-alone work is in progress for the advanced missile configuration with undeflected canards and tail fins in the same angle of attack range and at a more realistic pitching rate of 250 deg/s.

A Look at the Future

Two-dimensional viscous analyses with Reynolds-averaged Navier-Stokes equations are easily computed and give reliable results for most aerodynamic design purposes. Over the years, it has become evident that numerical solutions, including a transition model, most closely match the extensive

experimental results for a fin at high angles of attack in the transitional Reynolds number flight regime.

In recent years, three-dimensional viscous analysis has become a more common occurrence, enabled by more advanced computational vector processing. In fact, numerical investigations have been performed to compute the flow over delta and double-delta wings at high angles of attack, and successful efforts have been conducted to obtain major flow features with reasonable accuracy, including the very difficult phenomenon of vortex breakdown. In addition, preliminary computations have been successfully completed for an advanced missile configuration at several steady angles of attack using the OVERFLOW code with various turbulence models.

Figure 6.

Comparison of Measured and Computed Normal Forces and Pitching Moment Coefficients ("x" orientation).
 $M_\infty = 0.3, \phi = 45^\circ, \delta_{can} = 10^\circ, Re_D = .95 \times 10^6$.

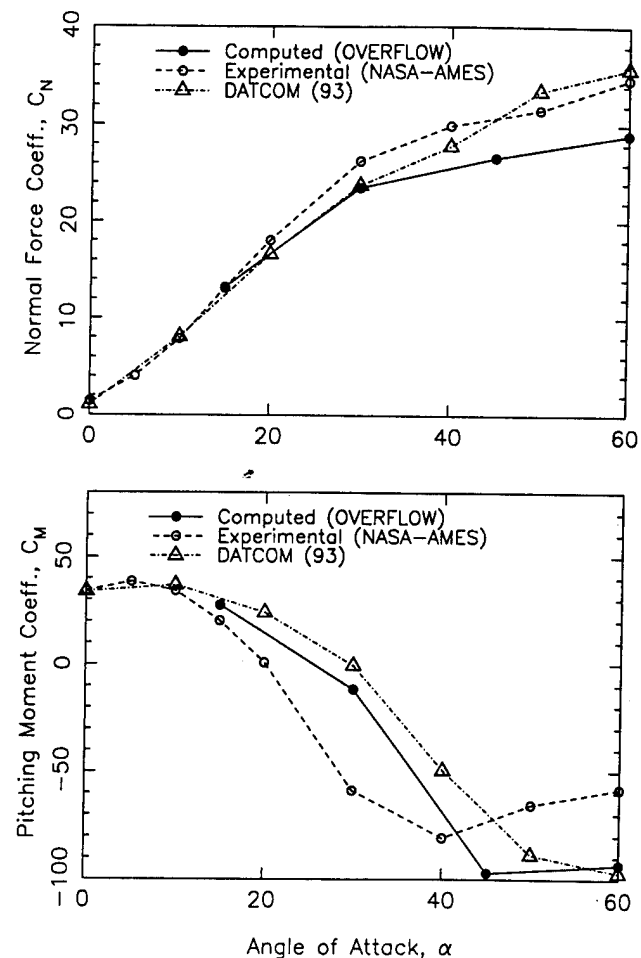
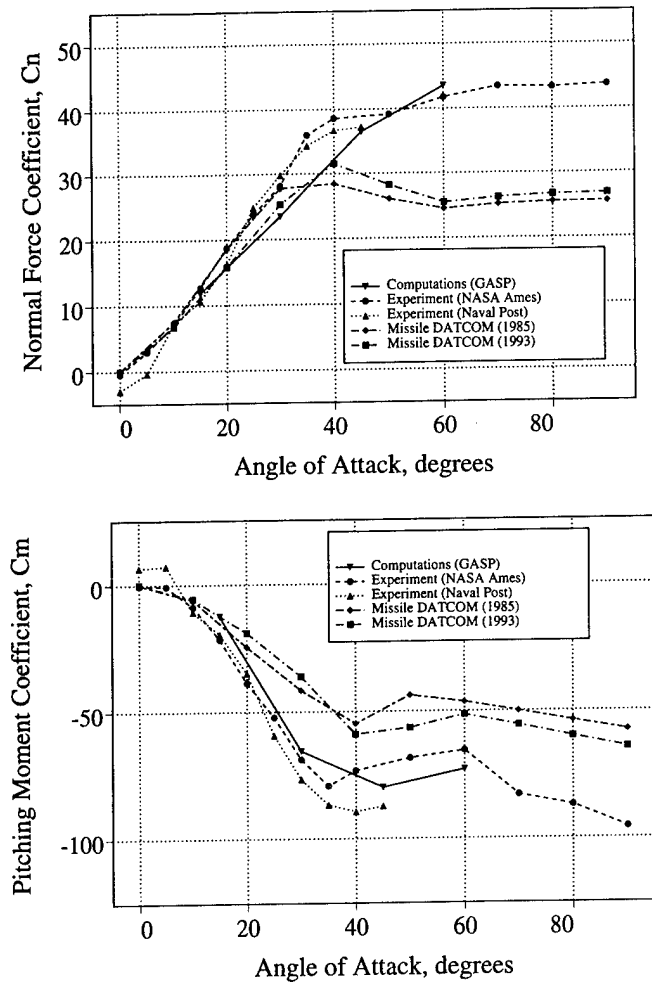

Figure 7.

Comparison of Measured and Computed Normal Forces and Pitching Moment Coefficients ("+" orientation).
 $M_\infty = 0.3, \phi = 0^0, \delta_{can} = 0^0, Re_D = .95 \times 10^6$.



As CFD capabilities advance, so does the confidence in this tool. Where in the past, wind tunnel tests, flight tests, and simulations were the workhorses in the development of missiles, today it is becoming more cost effective and advantageous to rely more on CFD work and less on the other methods, although some of each is still necessary.

As a direct result of CFD advances, design capability is quickly improving. In the near future, it will allow designers to rapidly predict performance and conduct static or dynamic stability analysis in the various design stages in an efficient and reasonably accurate manner. Understanding the mechanisms that generate vortex breakdown and the ability to predict its occurrence, for example, are crucial to efforts for improving missile designs and missile performance in flight at high angles of attack.

Acknowledgments

The author wishes to thank the Office of Naval Research, in particular Mr. David Siegel, the technology area manager, for his continued support of this project. The program is managed at China Lake by Dr. Craig Porter. Grateful thanks go also to Dr. M. Platzer, Dr. J. Ekaterinaris, and Dr. I. Tuncer of the Naval Postgraduate School, Monterey, and Dr. C. Hsieh of the Naval Surface Warfare Center, for their valuable contributions to this work.

Biography

Robert Van Dyken is currently a principal technical investigator at the Naval Air Warfare Center Weapons Division, China Lake, CA. He obtained his B.S. in Aerospace and Mechanical Engineering from Montana State in 1971, and his M.S. in ME from Cal State University, Northridge, in 1988. He is presently a PhD candidate in unsteady aerodynamics with emphasis on transitional fluid flow phenomena at the Naval Postgraduate School, Monterey.

References

1. Ying, S. X., Steger, J. L., Schiff, L. B., and Baganoff, D. "Numerical Simulation of Unsteady, Viscous High-Angle-of-Attack Flows Using a Partially Flux-Split Algorithm," AIAA Paper 86-2179, Aug. 1986.
2. Ekaterinaris, J. A. "Computations of Flowfields over Missile Configurations," 12th Applied Aerodynamics Con-

Figure 8.

Computed Helicity at Selected Missile Body Crossflow Planes, $M_\infty = 0.2, \alpha = 25^0$ (peak angle in oscillation cycle).

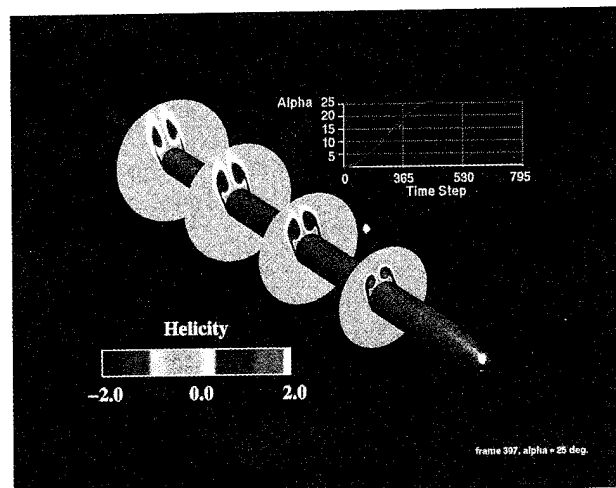

Figure 9.

Computed Helicity for Selected Missile Body Crossflow Planes, $M_\infty = 0.2$, (a) $\alpha = 15^\circ$ (up), (b) $\alpha = 15^\circ$ (down).

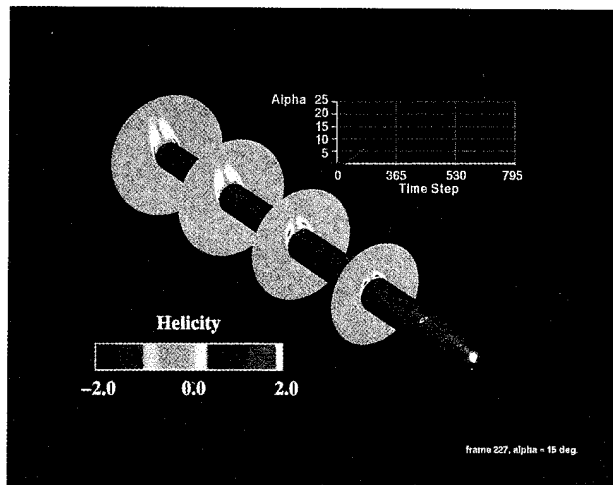
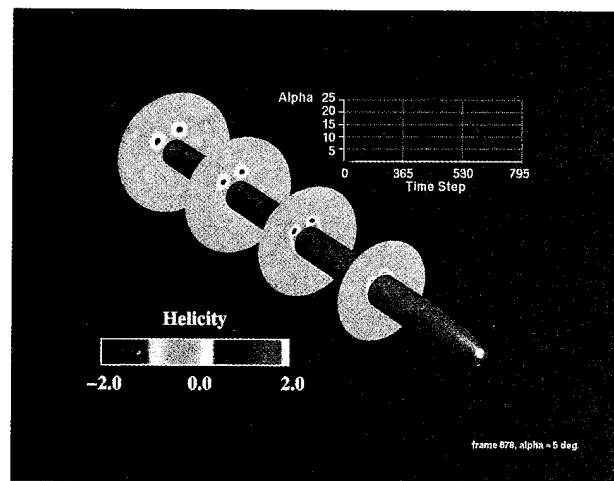
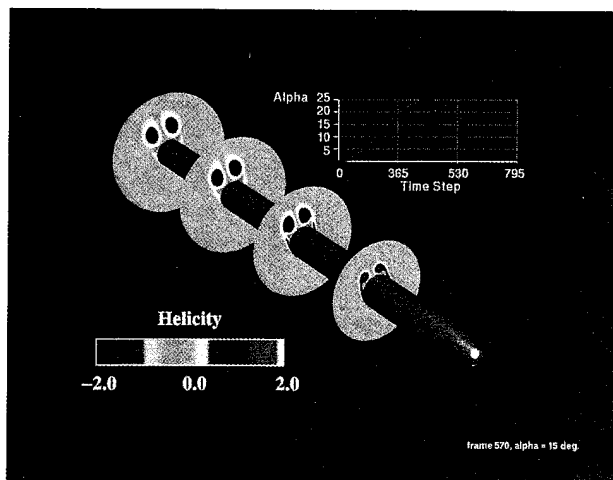
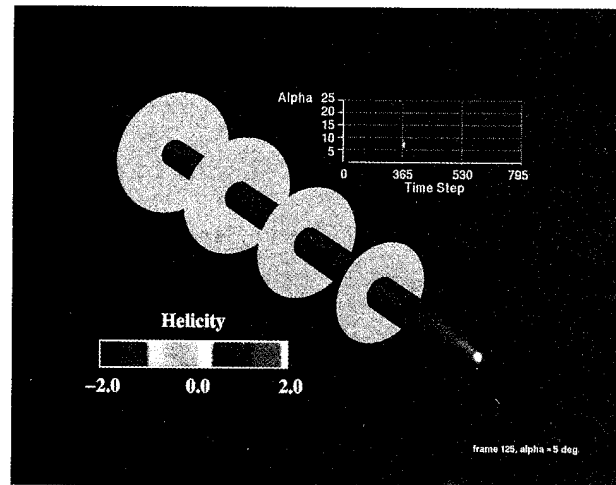

Figure 10.

Computed Helicity at Selected Missile Body Crossflow Planes, $M_\infty = 0.2$, (a) $\alpha = 5^\circ$ (up), (b) $\alpha = 5^\circ$ (down).



ference, Colorado Springs, CO, 20-23 June 1994. AIAA Paper No. 94-1915.

- Walters, R. W., Slack, D. C., Cinnella, P., Applebaum, M. P., and Frost, C. "A User's Guide to GASP," Virginia Polytechnic Institute and State University, Dept. of Aerospace and Ocean Engineering, Nov. 1990.
- Hsieh, T., Priolo, F. J., Wardlaw, A. B., Jr., and Van Dyken, R. D., "Navier-Stokes Calculation of Flow Over a Complete Missile to 60 Degree Incidence," 33rd Aerospace Sciences Meeting and Exhibit, 9-12 January 1995. AIAA Paper No. 95-0760.

- Thomas, J. L., Taylor, S. L., and Anderson, W. K. "Navier-Stokes Computations of Vortical Flows Over Low Aspect Ratio Wings," January 1987. AIAA Paper No. 87-0207.
- Hsieh, T., and Wardlaw, A. B., Jr. "Unsteady Aerodynamics of a Transient Pitching Missile Body from 0 to 25 Degrees," Paper presented at the Pacific International Conference on Aerospace Science and Technology, 6-9 December 1993. AIAA Paper No. 94-3500-CP.

Computational Combustion: Approaches to a Complex Phenomenon

*K. Kailasanath, Naval Research Laboratory
and
G. D. Roy, Office of Naval Research*

Introduction

Combustion is a complex phenomenon involving fluid dynamic mixing between the fuel and oxidizer, chemical reactions with the associated kinetics and thermodynamics, and heat transfer to the system and surroundings. It is further complicated by the complex geometries of the combustion chambers in use today. Current and future applications require increased energy release with reduced chamber volume, increased equilibrium temperatures, multiphase reacting flows with radiative heat transfer and sometimes even electric and magnetic fields. Basic understanding of the physical and chemical processes involved in combustion becomes a necessity for the design of efficient and reliable combustion systems.

Traditional development of combustion systems based largely on empirical data, and relatively simple design models will not be sufficient if energy utilization is to be maximized. Detailed full-scale experiments have become exceedingly expensive and often times very difficult. This is particularly so when a parametric evaluation is desired. On the other hand, "numerical experiments" open an avenue for isolating and understanding the influence of different parameters in complex combustion situations. It also provides a potential design tool for future combustion and propulsion systems. However, this is not simple or straight forward as will be discussed below.

Rapid advances in super computing and massively parallel processing has brought forth computational capabilities hitherto unheard of. Successful predictions of the detailed flow fields in complex aerodynamic systems have been demonstrated, and employed in design. Extension of Computational Fluid Dynamics (CFD) to combustion, oftentimes, has been considered as adding a few more terms in the governing fluid flow equations. However, when one realizes that combustion involves utilization of fuels and other species of vastly different molecular properties, chemical reactions with vastly different time scales, wide range of stoichiometry and load conditions, and slurries, gels, solids and gas-particle systems with precise thermal and exhaust emission management (for pollution and signature control), the complexity is obvious.

Because of the complexity of the problem, it is not feasible to directly simulate the turbulent reacting flow in a typical Navy propulsion system. Simplifying assumptions, sometimes drastic, need to be made. The simplifications will vary with the problem and in an industrial context may also depend on economic and temporal constraints. The resources allocated for computations and turn-around time needed is quite different in a design process than in a point design analysis or failure-analysis scenario. The level of detail included in the numerical models and the simplifying assumptions made will also be different depending on the problem to be solved and

the level of detail expected in the results. Therefore, in this paper, instead of focussing on a specific scenario of perhaps greater practical interest, we address the general problem of computational combustion. By doing so, we hope the reader will have an appreciation of the complexity of the combustion phenomena and the need to carefully choose the simplifying assumptions needed in particular applications.

The Office of Naval Research (ONR) has been sponsoring studies on computational combustion involving gaseous, liquid and solid fuels, and presently a new class of strained high-energy hydrocarbon fuels. Substantial accomplishments have been made, and the scientific understanding of combust-ing flows has been greatly enhanced by these studies. An attempt is made, in this paper, to address the various issues involved and the progress made in computationally simulating combustion problems of relevance to the Navy, with an emphasis on research sponsored by ONR.

For most Navy propulsion applications, combustion takes place in a turbulent flow. Hence, the approaches adopted to compute a turbulent flow, discussed elsewhere in this issue, are of interest to turbulent combustion. However, even for low Mach number applications, incompressible flow assumptions are not appropriate for combustion because of the large density changes and pressure waves generated by the energy released. In this report, we first discuss the various physical and chemical processes that must be considered in a general combustion problem. This brings out the complexity of the combustion phenomenon and the difficulties in trying to solve directly the governing equations. A laminar flame problem is used as an illustrative example since it one of the problems that can be solved directly and is often used to evaluate and calibrate simplified models for use in more practical Navy problems. This is followed by brief discussions of various approaches adopted in turbulent combustion in work sponsored by ONR and the progress made recently. Irrespective of the approach used for a particular problem, whether it be modeling or simulation, issues such as chemistry solvers and models, multiphase flow effects, soot, and heat transfer including radiation need to be considered in practical combustion problems. Therefore, the progress made in these areas are also highlighted with specific examples. Future prospects and research needs in computational combustion are discussed throughout and highlighted in the final section.

Computational Combustion

Computational combustion is sometimes thought of CFD with an additional source term in the energy equation to account for the heat released in chemical reactions. Although the overall exothermicity is what makes combustion of interest to Navy propulsion, there are various other physical and chemical processes involved in combustion that must be understood to optimize and control the energy release in order to

safely, cleanly and efficiently operate the propulsion systems. Some of the physical and chemical processes that must be considered in a typical combustion system is illustrated schematically in Figure 1.

The energetic decomposition of a fuel or the reaction of a fuel with an oxidizer produces a large number of intermediate species which need to be identified and tracked. The properties of these individual species such as their molecular weights and chemical properties are quite distinct. Therefore, as many convective transport equations as there are species are needed. In addition, these species tend to diffuse into each other, conduct heat to varying degrees and some of them may also radiate. Therefore, diffusive transport processes such as multi-species diffusion, heat conduction, viscous and thermal diffusion need to be considered. Furthermore, all these processes are coupled together and may interact with each other non linearly. In general, combustion takes place in confined geometries for propulsion applications, and therefore, heat transfer to the walls, boundary layers and surface reactions must also be considered. Quite often, the fuel is stored in the form of a liquid. Therefore, the atomization, droplet-gas interactions and vaporization of fuels need to be accounted for. Depending on the specific problem, external forces on the system such as buoyancy forces and magnetic and electrical fields may also need to be included. Because of the high temperatures and pressures encountered in some applications, various equations of state may also need to be considered.

The complexity of the problem of computational combustion is what also provides one of its major strengths. Since different interacting processes are accounted for, we can gain better understanding of many combustion problems by turning processes on and off or by assigning desired values for them. For example, the behavior of flames or fires in space can be simulated by assigning low or a zero value for the gravitational acceleration term in the governing equations. That is, a computational combustion model can be used as a tool to perform numerical experiments which are difficult, expensive or even

Figure 1.

A schematic illustration of some of the physical and chemical processes in a typical combustion system.

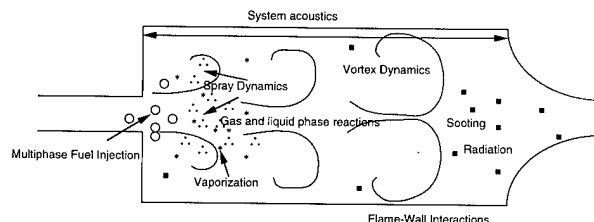

impossible to perform in the laboratory. These numerical experiments can provide valuable information for the design of new and innovative combustion devices and to improve existing designs.

Basic Numerical Requirements

It is not just the presence of additional terms in the governing equations that make the computation of combustion problems more complex than CFD, but the numerical requirements imposed by the underlying processes represented by these additional terms. The basic numerical requirements discussed here are applicable to both turbulent and laminar flame situations but the focus in the discussion below is more on a freely-propagating laminar flame. A laminar flame is of direct interest to the Navy because some of the most difficult fires to put out on ships are those from small fuel spills. They also have other dual-use applications such as burners. In addition to practical combustion problems, a more important use of the laminar flame is as a unit problem to test and evaluate sub-models such as for chemistry that is needed in other practical applications of interest to the Navy. A detailed model of a flame must contain accurate representations of at least the convective, diffusive, and chemical processes.

Diffusive transport processes play a very important role in flames and must be properly resolved. Numerically this means that any numerical diffusion in the calculation must be considerably less than any important physical diffusion effect. A Lagrangian method is ideally suited for the convective transport because eliminating the advection term in effect means eliminating numerical diffusion from the calculation. However, extending Lagrangian methods to multidimensions is both very difficult and expensive. Therefore Eulerian methods have to be considered for multidimensional flames. Eulerian methods have been successfully used to simulate flames, but these methods need finer grids than their Lagrangian counterparts in order to minimize numerical diffusion. Minimizing numerical diffusion is also important for maintaining the sharp gradients present in flames. Therefore, an important factor in the simulation of flame propagation is the choice of the spatial grid size or resolution.

Spatial resolution is achieved by having a large number of grid points in regions where the gradients are steep. In a detailed flame model, steep gradients in different species usually occur at different spatial locations necessitating the use of fine resolution all across the flame. The simplest gridding approach then would be to estimate the smallest grid size required to resolve the feature of the flame under investigation and use this grid size over the whole computational domain. The cost of such an approach is usually prohibitive and therefore a non-uniform grid is used where only a part of the computational domain is finely gridded (with small grid size). In a time-dependent problem, the flame may change its spatial location and then an adaptive gridding approach in which the

finely gridded region moves with some characteristic feature of the flame is chosen. This is feasible in one- or two-dimensional flows but extremely complex in three-dimensional flows in complex geometries.

Since flames are slow (when compared to the speed of sound), one would like to use large time-steps to study the dynamics. However, if an explicit method is used to advance the solution in time, very small time steps which are restricted by the speed of sound must be taken to keep the calculations numerically stable. Explicit methods are those in which the solution at the current time-step depends only the solutions at the previous steps. Explicit methods are easier to code and the cost per step is lower than implicit methods. Implicit methods are those in which the solution at the current time-step depends also on a previous estimate of the solution at the current time-step. Thus it requires an iterative procedure or matrix inversion and is more expensive per time-step. However, for slowly evolving problems, implicit methods are more efficient because they require fewer but larger time-steps to obtain the solution for a given time interval.

Simulating in detail the combustion of complex hydrocarbon fuels could easily involve hundreds of species and thousands of elementary reactions among them. Solving a set of detailed chemical reaction rate equations is usually the most expensive part of detailed flame models. In general, the numerical accuracy required of chemistry algorithms is lower in a fluid flow situation than in a purely chemical kinetics problem. So the emphasis on chemistry solvers is more on speed than on higher orders of accuracy. Some of the recent developments in faster chemistry solvers on parallel computers are discussed later.

The last but most important part of flame models is the coupling between the various processes. One approach is to solve all the equations simultaneously. This requires some form of iterative method because the equations are nonlinear. In general, this is a very expensive approach and difficult to efficiently parallelize but it has been adopted successfully in many specific situations such as the determination of burning velocity and a steady flame-structure. Another approach is to use an operator or time-step split procedure in which the individual processes are solved using the most efficient methods and then the solutions are appropriately coupled. Here particular care must be taken in the coupling procedure. This approach has been adopted successfully in a wide variety of reactive-flow calculations¹ and some examples are discussed later in this paper. A recent paper compares an operator-split scheme and unsplit scheme for the simulation of one-dimensional flames and comes to the conclusion that the split approach is slightly superior to the unsplit approach in problems involving detailed chemistry². Various approaches in between the process-splitting and the fully coupled approaches have also been taken and shown to give satisfactory results in many specific situations.

Figure 2.

Comparison of the instantaneous reaction-rate distributions from a reactive jet simulation with distributions of an intermediate chemical species (OH) used to characterize the experimental combustion regions. (Grinstein, Ref. 5)

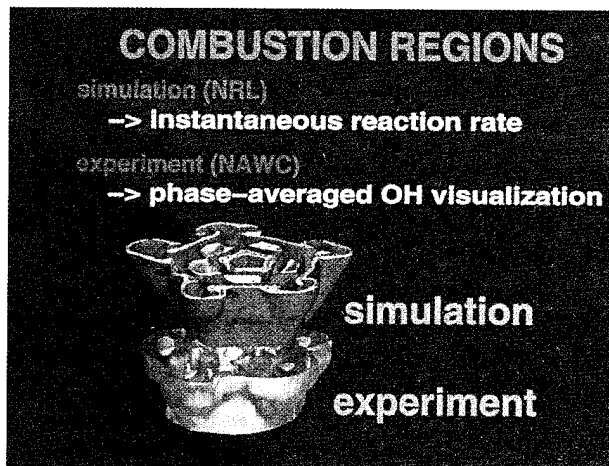

Turbulent Flows

Even with the rapid advances in computers and computational methodologies, it is not currently possible to simulate combustion in a complex propulsion device by directly solving the basic equations discussed above, because the flow is usually turbulent. The difficulties associated with and the issues that need to be addressed in simulating turbulent flows are discussed elsewhere in this issue. They are relevant to turbulent combustion and will not be elaborated on. Here, attention is focussed on additional issues that are specific to combustion.

Numerical simulations of turbulent combustion must be capable of resolving a broad range of spatial and temporal scales including multi-species transport. Direct numerical simulations (DNS) of combustion which involves directly solving the basic equations can be performed only for a small class of problems, typically involving low Reynolds (Re) numbers. For other problems of interest, simplifying assumptions need to be made. One of the simplifying assumptions that is often made in turbulent combustion is the assumption of a single-step global reaction between the fuel and the oxidizer. This not only simplifies the chemical kinetics but also reduces the number of species involved to a fuel, oxidizer, product(s) and usually a diluent. There are a number of papers dealing with a single-step reaction in conjunction with the DNS of the underlying fluid flow in very simple systems³. Research⁴ sponsored by ONR also considers the temperature and species dependent diffusive transport processes and realistic inflow

and outflow boundary conditions. This paper is part of a larger effort⁵ at the Naval Research Laboratory (NRL) to use numerical simulations to study the dynamics and topology of non-axisymmetric jets because of their enhanced characteristic entrainment properties relative to those of round jets. It shows that direct simulations are invaluable for obtaining a comprehensive understanding of phenomena such as axis-switching and its role in enhancing the mixing of non-circular jets over circular jets.

However, for higher Re number unsteady reactive flows in larger systems, it also brings out the need to adopt a large-eddy simulation (LES) approach. In the LES approach, the flow is decomposed into two parts. The first part contains the large scales and depends on the boundary conditions of the flow. The second part contains the small scales and is modeled using subgrid scale turbulence models. Adequate subgrid scale models for compressible, multi-species reactive flows do not exist now. Therefore, models from CFD⁶ or those implicit in non-linear algorithms⁷ such as the monotonically integrated large-eddy simulation (MILES) are usually used. In either case, comparisons and calibration with experiments need to be performed. For example, in Fig.~2, the instantaneous chemical reaction-rate distributions from a reactive jet simulation is compared with distributions of an intermediate chemical species (OH) used to characterize the experimental combustion regions. In this particular example, the axisymmetry of a circular jet is broken up by introducing vortex generators or tabs along the edge of the nozzle. This provides an alternate to using non-circular nozzles to enhance the mixing of a fuel jet with the surrounding air. With the confidence gained by comparisons to experimental data, numerical simulations can be used to gain insight into the details of mixing process using information such as the time evolving vorticity field which cannot be obtained in experiments.

Classical approaches to modeling turbulence based on a statistical treatment of fluctuations about a stationary or slowly varying state have also been adapted to combustion⁸. As in modeling non-reactive turbulent flows, the primary variables in the equations are divided into two parts: a mean, time-averaged part of the flow and a fluctuating part representing deviations from the mean. Models relating the fluctuations to the known quantities of the flow must be postulated to close the system of equations. The closures from the Reynolds averaged Navier Stokes (RANS) approaches in fluid dynamics are not sufficient because of the additional processes that must be considered in turbulent combustion. The large changes in density that is typical of combustion problems also suggests the use of averaging procedures such as the Favre or mass-averaged approach. As part of the ONR propulsion program, stochastic modeling of turbulent flows is also sponsored in addition to DNS and LES⁹. For example, the maximum rate of mean reactant conversion in a homogeneous turbulent reacting flow problem, obtained from a model is compared to DNS data

in Fig.-3. This also brings out another use of DNS, as a tool to perform idealized simulations (unit problems) to evaluate and calibrate models for use in more practical computations. More recently¹⁰, in this research effort both probability density function (pdf) and moment methods are considered with a focus on 1) mathematical modeling of the conditional statistics of scalars in turbulent mixing and reaction and 2) development of algebraic closures for the turbulent flux of scalars transported in reacting flows.

Even approaches based on solving the time-averaged multidimensional equations with phenomenological models for closure are often too expensive (time consuming) and not accurate enough for routine use in the design of combustors¹¹. The more common approach adopted in the industry is based on semi-empirical correlations¹¹. Significant advances still need to be made in simulating turbulent combustion for it to be used on a routine basis in an industrial environment driven more by cost than by technological advancements. With the current emphasis on timed fuel injection for increased fuel efficiency and reduced emissions, unsteady aspects of the flow will have to be resolved. This necessitates the development of a new class of turbulence models that are applicable for unsteady flows.

The approach adopted to compute the flow in a combustor or idealized representation of it, will depend on the specific problem under consideration. Time and cost constraints will always necessitate the use of models and approximations in practical combustion scenarios. In some cases, the focus may be on combustion instability and the role of large-scale vortex dynamics. In this case, resolving the inviscid vortex-dynamics and acoustics by solving the unsteady Euler equations may all that be required. Irrespective of the approach adopted, in combustion, additional processes such as chemical reactions and heat release, soot formation and destruction and heat transfer must be represented in terms of sub-models. Issues related to these processes and recent advances made in the research sponsored by ONR are discussed next.

Reduced Chemistry Models

The combustion of fuels involve the decomposition of the fuel, formation of intermediate species and reactions among them and the oxidizer to release chemical energy. Tens of species and hundreds of reactions among them are needed to represent the combustion of typical hydrocarbon fuels used in the Navy. In many situations, useful information can be obtained by considering the species to be in chemical equilibrium and ignoring the reaction kinetics. There are many other situations where the flow times and dynamics are such that, chemical equilibrium does not exist. However, solving a detailed set of elementary reactions in conjunction with a complex flow is prohibitively expensive. Therefore, there is a need to develop reduced chemistry models.

Figure 3.

Comparison of Model data (-) to DNS (□) for the temporal variation of normalized mean fuel concentration in a homogeneous turbulent reacting flow. (Givi et al., Ref. 9)

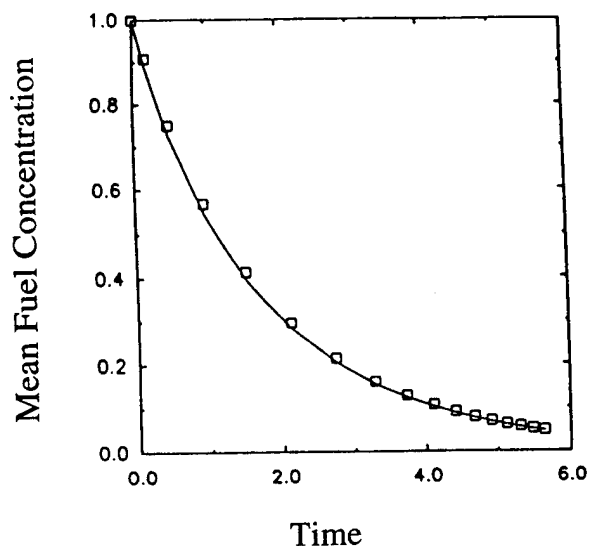

For example, with the current emphasis on environmentally-sound ships, there is a need for a predictive tool for the emission of NO_x from Diesel Engines and Gas turbines. The work of Williams¹² uses a four-step model for fuels of interest in Diesel combustion. In this approach, the first step is an overall fuel-consumption step that produces CO, H₂ and CO₂. The second step is the water-gas shift or CO consumption step. The third and fourth steps are associated with the radical recombination and oxygen consumption. The rates of these four reduced steps are derived from the rates of the elementary reactions.

In addition, a one-step description of the NO_x production is given by:

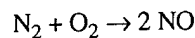

as the overall process. The elementary steps that determine the rate of this process depend on the specific mechanism of NO_x production. The relative importance in different scenarios of the three popular mechanisms of NO_x production can be assessed with the implementation of such reduced chemistry in the appropriate reactive flow simulation models. As an example, NO formation in a Heptane diffusion flame as predicted by different models is shown in Fig. 4. This brings out another valuable contribution that can be made by computational combustion. It also shows that further work needs to be done in improving the reduced chemistry models.

The systematic development of single-step or multi-step reduced chemistry models need a detailed reaction mechanism as the starting point. In addition, it is important to assess the validity of the simplified models by comparing the results obtained using them to those from detailed models. This is often done for a simplified unit problem such as a laminar premixed or diffusion flame or a shock-tube problem. Therefore, there is a need to develop efficient ways to compute multi-species reactive flow problems. Such an approach is discussed next.

Parallel Reactive-flow Simulations

As discussed previously, a reactive flow problem involves a variety of physical and chemical processes that evolve at their own characteristic time scales. An efficient approach to solve such problems is to use process or time-step splitting¹³. In this approach, the various processes are solved using appropriate algorithms and coupled together. However, this approach results in the amount of computations to be different at different grid points and to vary with time. For example, the chemistry solver will require different number of sub-cycles to compute for an overall time-step depending on the local stiffness of the solution at a specific grid-point at that time. Because of this difference in the amount of computations at different grid points, a simple domain decomposition approach where you distribute the various grid-points among the processors is not adequate. Therefore, a new approach has been developed in collaboration with the University of Maryland [Moon et al.¹⁴].

In this approach, the various processes in the flame are placed into one of two groups:

Structured, where the computation is based on structured meshes. Certain processes, e.g. heat conduction, are represented by partial differential equations which are discretized by a finite volume technique. In these methods, the solution procedure requires a good deal of communication with neighboring points, but the amount of computation at each point is nearly the same.

Independent, where computation at each grid point can be carried out independently without requiring any communication between neighboring points, e.g. chemistry. However, the solution procedure may require a different amount of computation at each grid point. This distribution of work load may change from time step to time step as the flame evolves.

In a flame simulation, the structured processes and the independent processes alternate within each time step. The implication here is that there exist two conflicting demands for efficient parallel computation: (1) the necessity of regular block partitioning of the grid to take advantage of simplicity and efficiency of the structured computation, and (2) the achievement of good load balance in the independent processes. Two sets of runtime support primitives, Multiblock

Figure 4.

Comparison of NO mole fraction in a Heptane diffusion flame as predicted by different chemistry models. (Williams, Ref. 12)

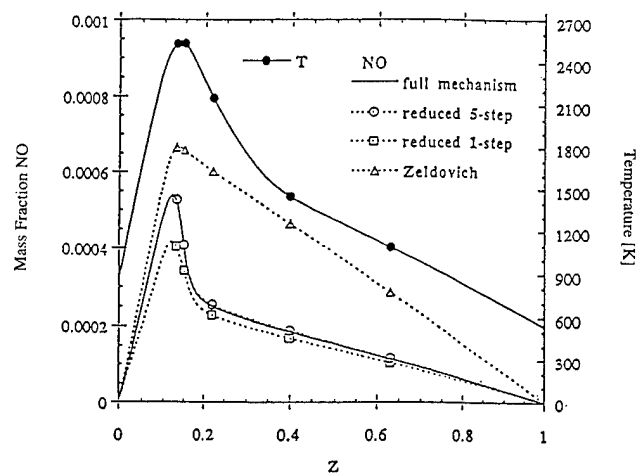

PARTI and CHAOS, (developed at the University of Maryland under an ONR initiative on Massively Parallel Computational Science) have been applied to cope with both of the demands successfully. In addition, a multigrid method, based on MAD-PACK is used as the solution technique for the elliptic equation that arises in the fluid convection model. To balance the work load of the independent processes, block-partitioned data must be redistributed across processors, and then moved back into the original locations for the next structured process. This approach inherently requires a substantial amount of communication to redistribute data every time step. New algorithms and runtime primitives which perform the redistribution of work load and minimize communication volume at low cost have been developed and tested.

With these advancements, the entire NRL flame code has been parallelized and test problems computed using it have produced identical results to those obtained using the Cray C-90 version. For a typical methane flame structure computation, it requires 64 nodes of the Intel Paragon or 16 nodes of the IBM SP2 to equal one C-90 processor. Figure 5 shows the scaling of the different processes in terms of the computational time per time step on different number of processors. All processes except the convection scale extremely well. Convection scales poorly because it requires communication across the entire grid. Fluid convection, however, takes only a small portion of the overall computational time and can be minimized by considering larger problems or problems involving more complex chemistry than methane. Thus, with the advances in parallel computers, larger and more complex flame problems can be solved with such an approach.

Modeling Effects of Heat Losses

Combustion in propulsion systems occurs in confined systems or at least in systems with walls. Heat transfer to such bounding surfaces from the burning flame must also be accounted for. Heat losses not only represent a loss of useful energy but may also play a significant role in determining the detailed structure, stability and dynamics of flames. Conductive heat losses, such as to a flame holder or burner can be accounted for by the choice of appropriate boundary conditions¹⁵. Information is needed on the material used for the combustor and its heat transfer characteristics. Surface chemistry such as recombination of radicals at the walls may also need to be included in some studies. Another form of heat loss is that due to radiation from by-products of combustion such as water, CO₂ and soot. It is fairly straight forward to formulate a sub-model to account for radiative losses if the flame can be assumed to be optically thin. This is a useful approximation when the self-absorption of radiation in the hot gas can be neglected. In this formulation we need information on the Planck mean absorption coefficient as a function of temperature for the species of interest. For example, an eighth-degree polynomial fit has been developed from data available in the literature for the absorption coefficient for water and CO₂¹⁶. Radiation from sooting flames is more complicated since the optically thin assumption may not be adequate. More complex radiation transport models have been considered in the diffusion flame studies of Kaplan et al.¹⁷. The effects of using different levels of radiation models and their input data are currently being investigated under the high-energy fuels combustion program¹⁸.

Multi-Phase Flows

So far the discussion has focused on the combustion of gaseous fuels. Although these models are directly applicable to pre-vaporized and super critical systems in addition to gaseous systems, many practical applications involve the combustion of liquid fuel sprays and heterogeneous gas-particle systems. While directly simulating the breakup and combustion of a multi-component fuel jet injected into a gaseous stream is beyond current capabilities, significant progress has been made in the simulation of single droplet combustion and the representation of dilute and dense sprays in gaseous background flows.

In the computational studies of energetic fuel droplet combustion, a spherically symmetric geometry is considered and the solution domain is divided into three regions: a liquid droplet core, a two-phase foamy layer and the surrounding gaseous region¹⁹ as shown schematically in Figure 6. The continuity, momentum, energy and species conservation equations are solved numerically in each region. An exothermic, temperature-dependent reaction mechanism is included in the liquid phase but mass diffusion in the liquid phase is neglected.

The input parameters for such a simulation include initial droplet size and temperature, ambient pressure and temperature, heat of reaction in the liquid, activation energy and pre-exponential constant for the liquid-phase reaction, and thermophysical properties for the gas and liquid. Progress to date using such an approach can be found in Ref.¹⁹.

Information on the vaporization and combustion of single droplets may be used as sub-models in the simulation of spray combustion. If the spray is dilute, it is feasible to track the motion of individual droplets or particles in a flow system. Such an approach has been used to study the dispersion of particles injected into the high-speed shear layer of an axisymmetric combustor. The particles' position in the flow field is computed by solving the Lagrangian equations of motion for the particles taking into account the inertial drag force that depends on the density and size of the particles. The flow field is computed using the MILES approach with the Flux-corrected Transport (FCT) algorithm. Details of the model as well as more comprehensive discussion of the various cases simulated are documented elsewhere²⁰ while only highlights are presented here.

For a typical case, an axisymmetric jet with a mean velocity of 100 m/s flows through a cylindrical inlet of diameter D into a cylindrical combustion chamber of twice the diameter. An annular exit at the end of the combustion chamber is modeled to produce choked flow. Particles are injected from the inlet-combustor junction with a stream wise velocity of 50 m/s and zero radial velocity. In Figure~7, the particle positions within the combustor for particles of different sizes are shown at a particular time, 20 000 time steps (~7.5 ms) from the start

Figure 5.

Scaling of different processes in a methane flame calculation on the Intel Paragon. (moon et al., Ref. 14)

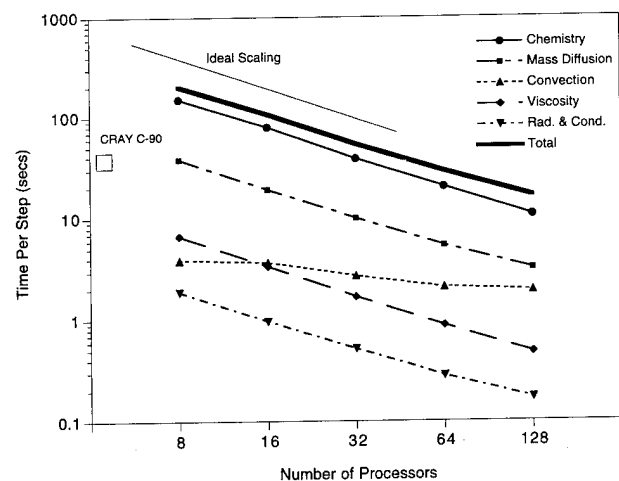

of the simulations. This figure highlights the distinctly different interactions between large-scale vortical structures and particles of different sizes. Very small particles such as the 1 micron particles are engulfed by the vortical structures and move with them. Very large particles such as the 30 micron particles are not strongly affected by the structures while the intermediate size particles show a strong interaction in the sense they appear to form distinct sheets as they are entrained along the outer regions of the vortical structures and then flung out. These observations support the different mechanisms for particle dispersion postulated in the earlier study of particle dispersion in axisymmetric jets²¹. Another significance of this study is on the choice of particle sizes used in flow diagnostics to track the fluid flow. It is also relevant to the combustion of multi-component fuels with additives that may remain in solid form in a gaseous background. For the combustion of dense sprays, the interactions among the different particles/droplets must also be taken into account. Furthermore, it is not computationally practical to follow individual particles when there are a very large number of them and they are of different sizes. The traditional method of modeling polydisperse sprays is to partition the initial droplet size distribution into bins and fix these bins so that during the calculation as the droplets evaporate, they can change bins. This becomes difficult for dense sprays because at a given location, the range in droplet sizes can be very large. A variation of this approach is currently being considered²². In this approach, only the initial droplet size distribution is partitioned into finite-size bins. Each size is then followed through the conservation equations in its own system of coordinates which moves with the droplets. Thus

Figure 6.

Schematic of a vaporizing liquid-fuel energetic droplet shows (a) the initial droplet at $t_1 = 0$, while (b) and (c) show the droplet at progressively longer times, t_2 and t_3 . (Sirignano et al., Ref. 19)

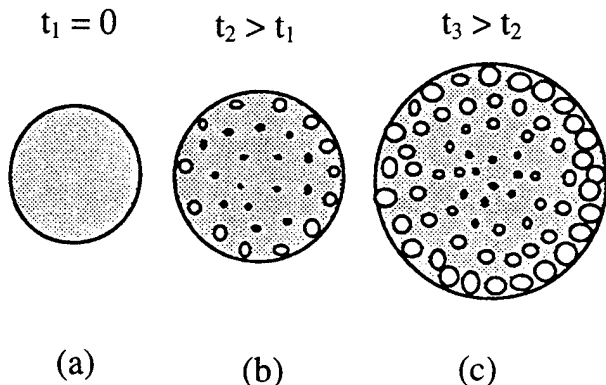
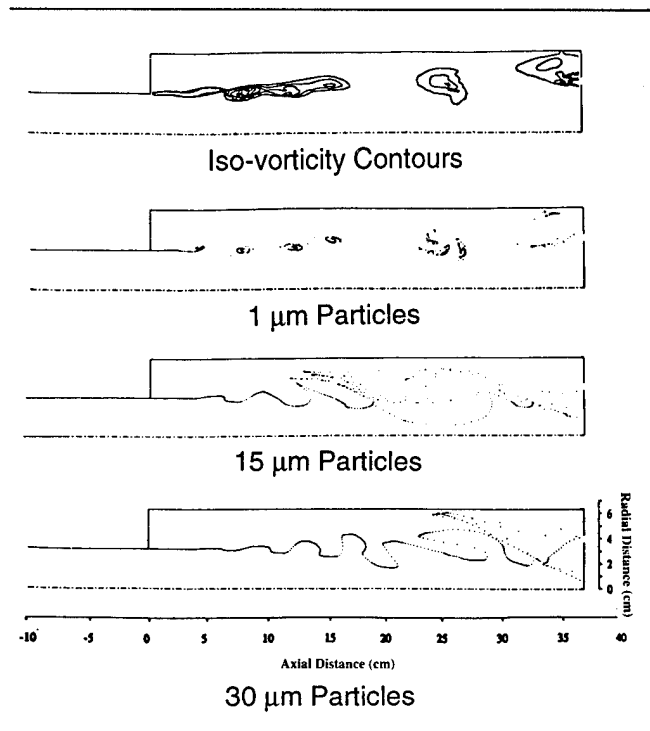

Figure 7.

Instantaneous spatial distribution of vorticity and particles of different sizes in an axisymmetric ramjet combustor. (Kailasanath et al., Ref. 18)



each initially mono-size bin develops a continuum of droplet sizes as the droplets evaporate. Parametric studies using this model suggest that polydispersity is beneficial to spray combustion in that the smaller droplets provide the fuel vapor to initiate the flame whereas the large droplets provide the means for the fuel to penetrate into the oxidizer and thus propagate the flame²².

The progress in the modeling of particles and droplets in fluid flows will also be useful in the simulation of the formation and destruction of soot.

Combustion of Sooting Fuels

Most often combustion in propulsion systems takes place in a diffusion flame scenario and most of the hydrocarbon fuels in use in the Navy have a tendency to soot. Particularly so are the new class of high-energy fuels being developed which have a large carbon to hydrogen ratio, and hence an increased sooting tendency. Reduction of soot is crucial to reduce signatures from propulsion system exhausts as well as to improve their efficiency. Numerical simulation of sooting flames is still in its infancy. Better chemical-mechanistic understanding of the formation and destruction of soot²³ is needed for the development of sub-models for inclusion in numerical simulations.

As a first step, sooting methane-air flames have been simulated using a flame sheet approximation²⁴. For these simulations, additional equations for the transport of soot volume fraction and number density have been formulated. The soot volume fraction is computed as a function of the local gas properties (temperature, density, fuel mole fraction) using a simplified model that is based on experimental measurements²⁵. However, the model does not consider the effects of nucleation, surface growth, coagulation, and oxidation.

In spite of the simplifications adopted in the model, comparisons between the computations and experiments show reasonable agreement in the overall location of the flame surface and the flame height. The temperature and soot volume fractions are also in reasonable agreement at most measurement locations. Although the comparisons are encouraging, further studies need to be made in more complex combustion scenarios.

Concluding Remarks

In this article, we have highlighted the unique computational issues that need to be addressed to simulate combustion problems relevant to the Navy's propulsion program. We have briefly reviewed the recent progress focusing on the work sponsored by the Navy, either directly by ONR or indirectly through NRL. The work takes advantage of developments in CFD but as discussed above there are also several unique aspects of combustion that must be addressed directly. Advances in computers and progress in computational methodology will continue to expand the range of problems that can be tackled. Because of the complexity of the combustion phenomenon, modeling of turbulence and other processes such as soot formation and destruction, radiation and chemistry will be required. With the increased emphasis on timed fuel injection for increased fuel efficiency and reduced pollution, more emphasis will be placed on modeling time-dependent turbulent combustion. Meanwhile, simulation of more idealized systems and scenarios have already made an impact in improving our current understanding of the dynamics and control of combustion. This is also paving the way for optimized design of complex combustion systems.

Biographies

Dr. K. Kailasanath is currently the Head of the Center for Reactive Flow and Dynamical Systems at the Naval Research Laboratory. His research interests include the structure, stability and dynamics of flames and detonations; combustion instabilities in ramjets; shock-induced combustion, multiphase flows, subsonic and supersonic mixing and noise generation; and the simulation of advanced propulsion system concepts such as Ram Accelerators. He is author or co-author of over one hundred papers in the above areas.

Gabriel D. Roy received his Ph.D. in Engineering Science from the University of Tennessee. He served as a faculty member for 12 years and as a researcher and research manager in university and industry for 15 years. At the Office of Naval Research since 1987, Dr. Roy manages the Propulsion and Pulse Power Physics programs. He has over 40 publications, and two patents. His research interests include plasma dynamics, MHD, pulse power, propulsion, fuels, and environmental pollution. He is an Associate Fellow of AIAA, and a member of the Sigma Xi Honor Society. He served as an Associate Editor of the *AIAA Journal of Propulsion and Power*.

References

1. Oran, E.S. and Boris, J.P., *Numerical Simulation of Reactive Flow*, Elsevier, New York, 1987.
2. Goyal, G., Paul, P.J., Mukunda, H.S., and Deshpande, S.M., *Combust. Sci. and Tech.* **60**, 167-189 (1988).
3. See Papers in Vol. 3 of the *Proceedings of the Ninth Symposium on Turbulent Shear Flows*, Kyoto, Japan, August 1993.
4. Grinstein, F.F. and Kailasanath, K., *Combust. Flame* **100**, 2-10 (1995)
5. Grinstein, F. F., "Dynamics and Topology of Non-Axisymmetric Jets", pp. 216-221, in *Proceedings of the Seventh ONR Propulsion Meeting*, Buffalo, NY, 1994.
6. Menon, S., and Yeung, P.K., "Analysis of Subgrid Models using Direct and Large-Eddy Simulations of Isotropic Turbulence", Paper No. 10, 74th AGARD Fluid Dynamics Panel Symposium on *Application of Direct and Large Eddy Simulation to Transition and Turbulence*, 1994. (see also AIAA Paper No. 94-2387, AIAA, Washington, DC)
7. Boris, J. P., Grinstein, F.F., Oran, E.S. and Kolbe, R.J., *Fluid Dyn. Res.*, **10**, 199 (1992).
8. Libby, P. A., and Williams, F.A. (Eds.), *Turbulent Reacting Flows*, Topics in Applied Physics, Vol. 44, Springer-Verlag, 1980.
9. Givi, P., Madnia, C.K., Frankel, S.H., Miller, R.S., Steinberger, C.J., and Adumitroaie, V., "DNS, LES and Stochastic Modeling of Turbulent Reacting Flows", pp. 128-131, in *Proceedings of the Sixth ONR Propulsion Meeting*, Boulder, CO, 1993.
10. Miller, R.S., Jaber, F.A., Adumitroaie, V., Taulbee, D.B., and Givi, P., "Stochastic Modeling and Simulation of Complex Reacting Turbulent Flows", pp. 260-269, in *Proceedings of the Seventh ONR Propulsion Meeting*, Buffalo, NY, 1994.
11. Mongia, H.C., "Dry Low Emissions Combustor Technology and Fundamental Research Challenges", pp. 1-18, in *Proceedings of the Seventh ONR Propulsion Meeting*, Buffalo, NY, 1994.

12. Williams, F.A., "Predictions of NO_x Emissions from Large Diesels, pp. 19-27, in *Proceedings of the Seventh ONR Propulsion Meeting*, Buffalo, NY, 1994.
13. Yanenko, N.N., *The Method of Fractional Steps*, Springer-Verlag, New York, 1971.
14. Moon, B., Patnaik, G., Bennett, R., Fyfe, D., Sussman, A., Saltz, J., Kailasanath, K. and Douglas, C., "Runtime Support and Dynamic Load Balancing Strategies for Structured Adaptive Applications, *Proceedings of the 7th SIAM Conference on Parallel Processing for Scientific Computing*, 1994.
15. Patnaik, G. and Kailasanath, K., "Simulations of Multidimensional Burner-Stabilized Flames, *AIAA Paper No. 93-0241*, AIAA, Washington, D.C., 1993.
16. Hubbard, G.L. and Tien, C.L., *J. Heat Transfer*, 100: 235-239, 1978.
17. Kaplan, C.R., Baek, S.W., Oran, E.S. and Ellzey, J.L., *Combustion & Flame*, 96:1-21, 1994.
18. Kailasanath, K., Chang, E., Patnaik, G. and Kaplan, C., "Numerical Simulations of Relevance to High Energy Fuels Combustion, pp. 153-158, in *Proceedings of the Seventh ONR Propulsion Meeting*, Buffalo, NY, 1994.
19. Zhu, Q.H., Schiller, D., Bhatia, R., and Sirignano, W.A., "Energetic Fuel Droplet Gasification with Liquid-Phase Reaction, pp. 19-27, in *Proceedings of the Seventh ONR Propulsion Meeting*, Buffalo, NY, 1994.
20. Chang, E.J. and Kailasanath, K., "Simulations of Particle Dynamics in an Axisymmetric Ramjet Combustor", *AIAA Paper No. 95-0812*, AIAA, Washington, D.C., 1995.
21. Uthuppan, J., Aggarwal, S.K., Grinstein, F.F. and Kailasanath, K., *AIAA J.*, 32, pp.2004-2014 1994.
22. Bellan, J., "Dispersion of Dense Sprays for Soot Control, pp. 19-27, in *Proceedings of the Seventh ONR Propulsion Meeting*, Buffalo, NY, 1994.
23. Gupta, S.B., Ni, T., and Santoro, R.J., "Chemical Mechanistic Approaches to Soot Control in High Energy Density Fuels, pp. 138-144, in *Proceedings of the Seventh ONR Propulsion Meeting*, Buffalo, NY, 1994.
24. Kaplan, C.R., Shaddix, C.R. and Smyth, K.C., "Experimental and Computed Profiles of Soot Volume Fraction and Temperature in a Laminar Methane-Air Diffusion Flame", submitted to *Combust. Flame*, 1995.
25. Syed, K.J., Stewart, C.D. and Moss, J.B., *Proceedings of the Twenty-Third Symposium (International) on Combustion*, The Combustion Institute, Pittsburgh, pp. 1533-1541, 1990.