

# AFCTN Test Report 94-028

AFCTB-ID  
93-002



## Technical Publication Transfer

Using:



Hughes Missile Systems Group's  
Data



MIL-M-28001A (SGML)  
MIL-R-28002A (Raster)  
MIL-D-28003 (CGM)



**DISTRIBUTION STATEMENT 4**  
Approved for public release;  
Distribution Unlimited

## Quick Short Test Report



20 January 1993

19960827 049



Prepared for

Electronic Systems Center

DTIC QUALITY INSPECTED 3

**Technical Publication Transfer**  
**Using:**  
**Hughes Missile Systems Group's Data**

**MIL-M-28001A (SGML)**

**MIL-R-28002A (Raster)**

**MIL-D-28003 (CGM)**

**Quick Short Test Report**

**20 January 1993**

---

**Prepared By**

Air Force CALS Test Bed  
Wright-Patterson AFB, OH 45433

**AFCTB Contact**

Gary Lammers  
(513) 427-2295

**AFCTN Contact**

Mel Lammers  
(513) 427-2295

**DTIC QUALITY INSPECTED 3**

## **DISCLAIMER**

This document was prepared as an account of work sponsored by the Air Force. Neither the United States Government, the Air Force, nor any of their employees, makes any warranty, express or implied, or assumes any legal liability or responsibility for the accuracy, completeness, or usefulness of any information, apparatus, product, or process disclosed, nor represents that its use would not infringe on privately owned rights. Reference herein to any specific commercial products, process, or service by trade name, trademark, manufacturer, or otherwise, does not necessarily constitute or imply its endorsement, recommendation, or favoring by the United States Government or the Air Force. The views and opinions of authors expressed herein do not necessarily state or reflect those of the United States Government or the Air Force, and shall not be used for advertising or product endorsement purposes.

Available to the public from the  
National Technical Information Service  
U.S. Department of Commerce  
5285 Port Royal Road  
Springfield, VA 22161

This report and those involved in its preparation do not endorse any product, process, or company stated herein. Use of these means by anyone does not imply certification by the Air Force CALS Test Network (AFCTN).

---

---

## Contents

1.	Introduction.....	1
1.1.	Background.....	1
1.2.	Purpose.....	2
2.	Test Parameters.....	3
3.	1840A Analysis.....	6
3.1.	External Packaging.....	6
3.2.	Transmission Envelope.....	6
3.2.1.	Tape Formats.....	6
3.2.2.	Declaration and Header Fields.....	6
4.	IGES Analysis.....	8
5.	SGML Analysis.....	8
6.	Raster Analysis.....	8
7.	CGM Analysis.....	10
8.	Conclusions and Recommendations.....	12
9.	Appendix A - Tapetool Report Logs.....	13
9.1.	Tape Catalog.....	13
9.2.	Tape Evaluation Log.....	14
9.3.	Tape File Set Validation Log.....	21
9.4.	Other Tape Reading Log.....	25
10.	Appendix B - Detailed SGML Analysis.....	26
10.1.	Parser Log.....	26
10.2.	Exoterica Parser.....	27

11.	Appendix C - Detailed Raster Analysis.....	28
11.1.	File D001R003.....	28
11.1.1.	Error Log validg4.....	28
11.1.2.	Output Harvard Graphics.....	29
11.1.3.	Output IGESView.....	30
11.1.4.	Output IslandPaint.....	31
11.1.5.	Output Preview.....	32
11.2.	File D001R003.....	33
11.2.1.	Error Log validg4.....	33
11.2.2.	Output Harvard Graphics.....	34
11.2.3.	Output IGESView.....	35
11.2.4.	Output IslandPaint.....	36
11.2.5.	Output Preview.....	37
11.3.	File D001R005.....	38
11.3.1.	Output Harvard Graphics.....	38
11.3.2.	Output IGESView.....	39
11.3.3.	Output IslandPaint.....	40
11.3.4.	Output Preview.....	41
11.3.5.	Output Ventura Publisher - All Files...	42
12.	Appendix D - Detailed CGM Analysis.....	43
12.1.	File D001C001.....	43
12.1.1.	Parser Log MetaCheck.....	43
12.1.2.	validcgm Log.....	45
12.1.3.	Output Harvard Graphics.....	47

---

- 12.1.4. Output cgm2draw/IslandDraw.....48
- 12.1.5. Output IslandDraw.....49
- 12.2. File D001C002.....50
  - 12.2.1. Parser Log MetaCheck.....50
  - 12.2.2. validcgm Log.....51
  - 12.2.3. Output Harvard Graphics.....53
  - 12.2.4. Output cgm2draw/IslandDraw.....54
  - 12.2.5. Output IslandDraw.....55
  - 12.2.6. Output Ventura Publisher - All Files...56

## 1. Introduction

### 1.1 Background

The Department of Defense (DoD) Air Force Continuous Acquisition and Life-Cycle Support (CALs) Test Network (AFCTN) is conducting tests of the military standard for the Automated Interchange of Technical Information, MIL-STD-1840A, and its companion suite of military specifications. The AFCTN is a DoD sponsored confederation of voluntary participants from industry and government managed by the Electronic Systems Center (ESC).

The primary objective of the AFCTN is to evaluate the effectiveness of the CALS standards for technical data interchange and to demonstrate the technical capabilities and operational suitability of those standards. Two general categories of tests are performed to evaluate the standards; formal and informal.

Formal tests are large and comprehensive, which follow a written test plan, require specific authorization from the DoD, and may take months to prepare, execute, and report.

Informal tests are quick and short, used by the AFCTN technical staff, to broaden the testing base. They include representative samples of the many systems and applications used by AFCTN participants. They also allow the AFCTN staff to gain feedback from many industry and government interpretations of the standards, to increase the base of participation in the CALS initiative, and respond to the many requests for help that come from participants. Participants take part voluntarily, benefit by receiving an evaluation of their latest implementation (interpretation) of the standards, interact with the AFCTN technical staff, gain experience using the standards, and develop increased confidence in them. The results of informal tests are reported in Quick Short Test Reports (QSTRs) that briefly summarize the standard(s) tested, the hardware and software used, the nature of the test, and the results.

---

## 1.2 Purpose

The purpose of the informal test, reported in this QSTR, was to analyze Hughes Missile Systems' interpretation and use of the CALS standards in transferring technical publication data. Hughes used its CALS Technical Data Interchange System to produce data, in accordance with the standards, and delivered it to the AFCTN technical staff on a 9-track magnetic tape.

## 2. Test Parameters

Test Plan: AFCTB 93-002

Date of Evaluation: 20 January 1993

Evaluators: George Elwood  
Air Force CALS Test Bed  
DET 2 HQ ESC/AV-2P  
Suite 300  
4027 Colonel Glenn Hwy  
Dayton OH 45431-1672

Data Originator: Marilyn Lopez  
Hughes Missile System Group  
P.O. Box 7928  
Bldg 276 M/S T13  
8433 Fallbrook Avenue  
Canoga Park, CA 91309  
(818) 702-3131

Data Description: Technical Manual Test  
1 Document Declaration file  
1 Document Type Definition (DTD)  
1 Text/Standard Generalized Markup Language (SGML) file  
3 Raster files  
2 Computer Graphic Metafile (CGM) files

Data Source System:

Text/SGML

**HARDWARE**

Unknown

**SOFTWARE**

Unknown

Raster

**HARDWARE**

Unknown

**SOFTWARE**

Unknown

CGM

**HARDWARE**

Unknown

**SOFTWARE**

Unknown

**Evaluation Tools Used:**

**MIL-STD-1840A (TAPE)**

SUN 3/280

AFCTN Tapetool v1.2.8 UNIX  
XSoft CAPS/CALS v40.4

**MIL-M-28001 (SGML)**

SUN SparcStation 2

ArborText ADEPT v4.2.1  
SoftQuad Author/Editor v2.1

Cheetah Gold 486

Exoterica XGMLNormalizer v1.2e3.2  
Exoterica OmniMark  
SoftQuad Author/Editor v2.1  
McAfee & McAdam Sema Mark-it v2.2.2

**MIL-R-28002 (Raster)**

SUN SparcStation 2

ArborText g42tiff  
XSoft CAPS ccitt2caps v6.0x  
AFCTN validg4  
AFCTN calstb.475  
IGES Data Analysis (IDA) IGESView v3.0  
Island Graphics IslandPaint v3.0

Cheetah

Inset Systems HiJaak v2.02  
Software Publishing Corporation  
(SPC) Harvard Graphics v3.0  
Corel Ventura Publisher

**MIL-D-28003 (CGM)**

SUN SparcStation 2

XSoft CAPS cgm2ps v6.0x  
ArborText cgm2draw  
Island Graphics IslandDraw v3.0

Cheetah Gold 486

Advance Technology Center  
(ATC) MetaView R 1.12  
ATC MetaCheck R 2.05

---

*SPC Harvard Graphics v3.0*  
*Inset Systems HiJaak v2.02*  
*Micrografx Designer v3.1*  
*Micrografx Charisma v2.1*  
*Corel Ventura Publisher*

**Standards**

**Tested:**

MIL-STD-1840A  
MIL-M-28001A  
MIL-R-28002A  
MIL-D-28003

### **3. 1840A Analysis**

#### **3.1 External Packaging**

The tape arrived at the Air Force CALS Test Bed (AFCTB) enclosed in a box in accordance with ASTM D 3951. The exterior of the box was marked with the magnetic tape warning label, as required by MIL-STD-1840A, para. 5.3.1.3.

The tape was enclosed in a barrier bag as required by MIL-STD-1840A, para. 5.3.1.2. Inspection of the tape reel showed the label indicating the recording density, as required by MIL-STD-1840A, para. 5.3.1. Enclosed in the box was a packing list showing all files recorded on the tape.

#### **3.2 Transmission Envelope**

The nine-track tape received by the AFCTB contained MIL-STD-1840A files. The files were named per the standard conventions.

##### **3.2.1 Tape Formats**

The tape was run through the AFCTB *Tapetool v1.2.8* utility. No errors were reported while evaluating the contents of the tape labels.

No errors were reported when the tape was read using the XSoft *CAPS read1840A* utility.

##### **3.2.2 Declaration and Header Fields**

Four errors and four notes were reported in the Document Declaration file and data file headers. In file D001, an Invalid change level was flagged. The value inserted was "0" while MIL-STD-1840A, para. 5.1.1.2 shows the change level as "ORIGINAL" or the revision number, change level number and change level date.

---

chglvl: 0

\*\*\* ERROR (MIL-STD-1840A; 5.1.1.2) - Invalid change level encountered.  
\*\*\* NOTE (MIL-STD-1840A; 5.1.1.2) - Change level should be the word ORIGINAL or a Revision Number followed by a Change Level Number followed by a Change Level Date. They should be separated by a comma or space.

The next error was reported in file D001R003 and D001R004. The error was the use of an invalid value for the Raster density.

rdensty: 0130

\*\*\* ERROR (MIL-R-28002; 3.1.1.2) - Invalid value for 'rdensty:'.  
Expected image density => 200, 240, 300, 400, 600, or 1200.

The last reported error was in file D001R005. The txtfilid record contained and incorrect value. Note, the correct value was inserted in the two Raster files immediately in front of this file.

txtfilid: NONE

\*\*\* ERROR (MIL-STD-1840A; 5.1.4.4) TABLE II - Invalid value for 'txtfilid:'.  
\*\*\* NOTE (MIL-STD-1840A; 5.1.4.4) TABLE II - The value for 'txtfilid:' should be 'W' when there is only one text file.  
\*\*\* NOTE - The header record will be given the value W.  
\*\*\* NOTE - Correction made in new %s Header File.

This portion of the tape does not meet the CALS MIL-STD-1840A requirements.

#### 4. IGES Analysis

No Initial Graphics Exchange Specification (IGES) files were included on this tape.

#### 5. SGML Analysis

The Text files from this document were tested using the Exoterica XGML parser. The DTD and Text file parsed without a reported errors.

#### 6. Raster Analysis

All three Raster files were evaluated using the AFCTN *validg4* utility. This program reported that files D001R003 and D001R004 were not valid files. The error message indicated an error at the end of the file. When an octal dump was made of the file it was noted that the required end of file coding was not present. Shown below is the octal dump from file D001R003 and D001R004. Note that the end-of-file coding is not present.

```
0011000 045733 143512 154040 054100 115510 137530 021236 133115
0011020 143305 030364 153322 104210 104151 022041 042107 177777
0011040 177777 177400 057136 057136 057136 057136 057136 057136
0011060 057136 057136 057136 057136 057136 057136 057136 057136
```

\*

```
0011200
```

```
0043060 177777 177777 177131 112401 124066 077777 177131 105440
0043100 050146 002406 060120 063005 003140 050146 002406 060331
0043120 177777 177777 177777 177777 177777 177777 177626 064330
0043140 014612 037777 177626 110650 026613 177777 174551 126203
0043160 053777 177743 177777 177777 177777 177776 000040 001000
0043200
```

```
~~~~~
End-of-file coding
```

All 3 Raster images were checked using the AFCTN *calstb.475* utility. Files D001R003 and D001R004 displayed and resulted in a core dump. File D001R005 displayed without a problem.

The files were converted using Rosetta Technologies' *Prepare* without a reported problem. The resulting files were read into Rosetta Technologies' *Preview*, displayed and printed without a problem. File D001R003 and D001R005 were not high quality images.

The files were imported directly into IDA's *IGESView* without a reported problem. The images were displayed and printed without a problem.

The files were converted to both PCX and IMG format using Inset Systems' *HiJaak*. No problems were reported.

The PCX files were imported into SPC's *Harvard Graphics v3.05* without a problem.

The IMG files were imported into Corel's *Ventura Publisher* without a reported problem.

Because of the missing EOF coding on files D001R003 and D001R004, the Raster files do not meet the CALS MIL-D-28002A specification.

## 7. CGM Analysis

The tape contained two CGM files. Both files were evaluated using ATC's *MetaCheck* with CALS options. This utility reported that both files meet the CALS MIL-D-28003 specification. *MetaCheck* reported many basic errors in file D001C001. All of these errors were zero area polygons.

Bulletin 20002: Element Class/ID: 4/8    Offset: 4634 octets Element No. 328  
Warning; zero area POLYGON SET.

Both files were evaluated using the beta AFCTN *validcgm* utility. This program reported several errors, in both basic CGM and CALS CGM. The log files are included in the Appendix to this report.

The AFCTB has many different CGM utilities available. The results are presented below. The AFCTB does not endorse any of the tools but reports the results in an effort to develop a more complete picture of submitted files.

An attempt was made to read the CGM files into the *Micrografx Designer 3.1* and *Charisma 2.1*. Both of these program reported internal errors and would not import the files.

According to Michael Harrison of Micrografx, "Micrografx is aware of the problems associated with reading these files and is working on a solution to be implemented in a future release of our products."

The files were imported into SPC's *Harvard Graphics v3.05*. File D001C001 had three reported errors during this procedure, clipped objects, non-CGM entities, and adjusted points. File D001C002 had no reported errors. When file D001C001 was displayed on the screen, the bottom part of the image was missing. The text font size was large and overflowed the desired areas. File D001C002 appeared to be correct.

The files were imported into Corel's *Ventura Publisher* without a reported error. File D001C001 appeared upside

down and all text was missing. The image did appear to be complete. File D001C002 appeared to be complete although the text size was too small to read.

The files were converted using ArborText's *cgm2draw* utility with no reported errors. The resulting files were read into Island Graphics' *IslandDraw*, displayed and printed. File D001C001 appeared to be upside down. This included the text. Many of the circles were displaced from where they should be located. File D001C002 appeared to be correct with the exception of displaced circles.

NOTE: Per Andrew Bridge of Island Graphics, "The *IslandDraw v3.0*, which was used for this report, is not the most current version available." Version 4.0 was made available to the AFCTB in August of 1993 and will be used on all future tests conducted.

The files were directly imported into Island Graphics' *IslandDraw*. No problems were reported during this procedure. File D001C001 had many displayed problems, see the hard copy in the Appendix. File D001C002 appeared to be correct.

The files were viewed using ATC's *MetaView* software. File D001C001 was missing the bottom of the image and had many misaligned parts. File D001C002 had a text font size problem and a reported error.

Even though the files were reported as meeting the CALS MIL-D-28003 specification by ATC's *MetaCheck*, file D001C001 was not usable in the publishing systems available in the AFCTB, and therefore does not meet the specification.

## 8. Conclusions and Recommendations

In summary, the tape from Hughes Missile Systems has problems in the CALS headers. For this reason, the tape does not meet the CALS MIL-STD-1840A requirements.

The DTD and text were parsed using several tools available in the AFCTB. The DTD and text files meet the CALS MIL-M-28001A specification.

The errors with the Raster images are serious. The construction of the Raster files D001R003 and D001R004 appears to be flawed with missing EOF coding. Even though the coding was not correct, the tools available in the AFCTB were able to display and print the files. The Raster files do not meet the CALS MIL-R-28002A specification.

The two CGM files meet the CALS MIL-D-28003 specification by ATC's *MetaCheck*. When the files were imported into various tools available in the AFCTB, file D001C001 was found to be unusable. The CGM file does not meet the CALS MIL-D-28003 specification.

The tape provided by Hughes Missile Systems does not meet the CALS MIL-STD-1840A requirements.

---

## 9. Appendix A - Tapetool Report Logs

### 9.1 Tape Catalog

Air Force CALS Test Network Catalog Evaluation - Version 1.2; Release Number 8

Standards referenced:

- MIL-STD-1840A (1987) - Automated Interchange of Technical Information
- MIL-R-28003 (1988) - Digital Representation For Communication Of Illustration Data; CGM Application Profile
- ANSI X3.27 (1987) - File Structure and labeling of Magnetic Tapes for Information Interchange
- ANSI X3.4 (1986) - Coded Character Sets - 7 Bit ASCII

Tue Jan 19 08:57:17 1993

MIL-STD-1840A File Catalog

File Set Directory: /cals/tapetool8/Set096

Page: 1

File Name	File Type	Record Format/ Length	Block Length/Total	Selected/ Extracted
D001	Document Declaration	D/00260	02048/000001	Extracted
D001C001	CGM	F/00080	00800/000013	Extracted
D001C002	CGM	F/00080	00800/000014	Extracted
D001R003	Raster	F/00128	02048/000003	Extracted
D001R004	Raster	F/00128	02048/000008	Extracted
D001R005	Raster	F/00128	02048/000009	Extracted
D001T006	Text	D/00260	02048/000023	Extracted
D001G007	DTD	D/00260	02048/000027	Extracted

Catalog Process terminated normally.

## 9.2 Tape Evaluation Log

Air Force CALS Test Network Tape Evaluation - Version 1.2; Release Number 8  
Standards referenced:

- ANSI X3.27 (1987) - File Structure and labeling of Magnetic Tapes  
for Information Interchange
- ANSI X3.4 (1986) - Coded Character Sets - 7 Bit ASCII

Tue Jan 19 08:57:08 1993

ANSI Tape Import Log

Allocating tape drive /dev/rmt0...

/dev/rmt0 allocated.

VOL1CALS01

4

Label Identifier: VOL1  
Volume Identifier: CALS01  
Volume Accessibility:  
Owner Identifier:  
Label Standard Version: 4

HDR1D001                    CALS0100010001000100 92350 00000 000000Ileaf Ver 1.6

Label Identifier: HDR1  
File Identifier: D001  
File Set Identifier: CALS01  
File Section Number: 0001  
File Sequence Number: 0001  
Generation Number: 0001  
Generation Version Number: 00  
Creation Date: 92350  
Expiration Date: 00000  
File Accessibility:  
Block Count: 000000  
Implementation Identifier: Ileaf Ver 1.6

HDR2D0204800260

00

Label Identifier: HDR2  
Recording Format: D  
Block Length: 02048  
Record Length: 00260  
Offset Length: 00

---

\*\*\*\*\* Tape Mark \*\*\*\*\*

Actual Block Size Found = 2048 Bytes.

Number of data blocks read = 1.

\*\*\*\*\* Tape Mark \*\*\*\*\*

EOF1D001 CALS0100010001000100 92350 00000 000001Ileaf Ver 1.6

Label Identifier: EOF1  
File Identifier: D001  
File Set Identifier: CALS01  
File Section Number: 0001  
File Sequence Number: 0001  
Generation Number: 0001  
Generation Version Number: 00  
Creation Date: 92350  
Expiration Date: 00000  
File Accessibility:  
Block Count: 000001  
Implementation Identifier: Ileaf Ver 1.6

EOF2D0204800260 00

Label Identifier: EOF2  
Recording Format: D  
Block Length: 02048  
Record Length: 00260  
Offset Length: 00

\*\*\*\*\* Tape Mark \*\*\*\*\*

HDR1D001C001 CALS0100010002000100 92350 00000 000000Ileaf Ver 1.6

Label Identifier: HDR1  
File Identifier: D001C001  
File Set Identifier: CALS01  
File Section Number: 0001  
File Sequence Number: 0002  
Generation Number: 0001  
Generation Version Number: 00  
Creation Date: 92350  
Expiration Date: 00000  
File Accessibility:  
Block Count: 000000

---

Implementation Identifier: Ileaf Ver 1.6

HDR2F0080000080 00

Label Identifier: HDR2  
Recording Format: F  
Block Length: 00800  
Record Length: 00080  
Offset Length: 00

\*\*\*\*\* Tape Mark \*\*\*\*\*

Actual Block Size Found = 800 Bytes.

Number of data blocks read = 13.

\*\*\*\*\* Tape Mark \*\*\*\*\*

EOF1D001C001 CALS0100010002000100 92350 00000 000013Ileaf Ver 1.6

Label Identifier: EOF1  
File Identifier: D001C001  
File Set Identifier: CALS01  
File Section Number: 0001  
File Sequence Number: 0002  
Generation Number: 0001  
Generation Version Number: 00  
Creation Date: 92350  
Expiration Date: 00000  
File Accessibility:  
Block Count: 000013  
Implementation Identifier: Ileaf Ver 1.6

EOF2F0080000080 00

Label Identifier: EOF2  
Recording Format: F  
Block Length: 00800  
Record Length: 00080  
Offset Length: 00

\*\*\*\*\* Tape Mark \*\*\*\*\*

<<<< PART OF LOG REMOVED HERE >>>>

\*\*\*\*\* Tape Mark \*\*\*\*\*





File Identifier: D001T006  
File Set Identifier: CALS01  
File Section Number: 0001  
File Sequence Number: 0007  
Generation Number: 0001  
Generation Version Number: 00  
Creation Date: 92350  
Expiration Date: 00000  
File Accessibility:  
Block Count: 000023  
Implementation Identifier: Ileaf Ver 1.6

EOF2D0204800260

00

Label Identifier: EOF2  
Recording Format: D  
Block Length: 02048  
Record Length: 00260  
Offset Length: 00

\*\*\*\*\* Tape Mark \*\*\*\*\*

HDR1D001G007

CALS0100010008000100 92350 00000 000000Ileaf Ver 1.6

Label Identifier: HDR1  
File Identifier: D001G007  
File Set Identifier: CALS01  
File Section Number: 0001  
File Sequence Number: 0008  
Generation Number: 0001  
Generation Version Number: 00  
Creation Date: 92350  
Expiration Date: 00000  
File Accessibility:  
Block Count: 000000  
Implementation Identifier: Ileaf Ver 1.6

HDR2D0204800260

00

Label Identifier: HDR2  
Recording Format: D  
Block Length: 02048  
Record Length: 00260  
Offset Length: 00

\*\*\*\*\* Tape Mark \*\*\*\*\*

---



### 9.3 Tape File Set Validation Log

Air Force CALS Test Network File Set Evaluation - Version 1.2; Release Number 8  
Standards referenced:

MIL-STD-1840A (1987) - Automated Interchange of Technical Information  
MIL-R-28002 (1989) - Raster Graphics Representation In Binary  
Format, Requirements For

Tue Jan 19 08:57:17 1993

MIL-STD-1840A File Set Evaluation Log

File Set: Set096

Found file: D001

Extracting Document Declaration Header Records...

Evaluating Document Declaration Header Records...

srcsys: hmsc\_cals\_training\_document

srcdocid: sun1

srcrelid: ASG\_manual\_AFCTN

chglvl: 0

\*\*\* ERROR (MIL-STD-1840A; 5.1.1.2) - Invalid change level encountered.

\*\*\* NOTE (MIL-STD-1840A; 5.1.1.2) - Change level should be the word ORIGINAL or  
a Revision Number followed by a Change Level Number followed by  
a Change Level Date. They should be separated by a comma or space.

dteisu: 15 December 1992

dstsys: AFCTN

dstdocid: AFCTN

dstrelid: AFCTN

dtetm: 19921216

dlvacc: NONE

filcnt: T1, G1, R3, C2

ttlcls: Unclass

doccls: Unclass

doctyp: Maintenance Manual

docttl: Acoustic Sound Generator

1 error(s), 0 warning(s), and 1 note(s) were encountered  
in Document Declaration File D001.

Found file: D001C001

Extracting CGM Header Records...

Evaluating CGM Header Records...

srcdocid: sun1

---

dstdocid: AFCTN  
txtfilid: W  
figid: 1  
srcgph: ASG-1  
doccls: Unclass  
notes: NONE

Saving CGM Header File: D001C001\_HDR  
Saving CGM Data File: D001C001\_CGM

Found file: D001C002  
Extracting CGM Header Records...  
Evaluating CGM Header Records...

srcdocid: sun1  
dstdocid: AFCTN  
txtfilid: W  
figid: 01  
srcgph: ASG  
doccls: Unclass  
notes: Figure 1-1

Saving CGM Header File: D001C002\_HDR  
Saving CGM Data File: D001C002\_CGM

Found file: D001R003  
Extracting Raster Header Records...  
Evaluating Raster Header Records...

srcdocid: sun1  
dstdocid: AFCTN  
txtfilid: W  
figid: 03  
srcgph: pack  
doccls: Unclass  
rtype: 1  
rorient: 000,270  
rpelcnt: 000472,000653  
rdensty: 0130  
\*\*\* ERROR (MIL-R-28002; 3.1.1.2) - Invalid value for 'rdensty:'.  
Expected image density => 200, 240, 300, 400, 600, or 1200.  
notes: Figure 1-3

1 error(s), 0 warning(s), and 0 note(s) were encountered  
in Raster File D001R003.

Saving Raster Header File: D001R003\_HDR  
Saving Raster Data File: D001R003\_GR4

---

Found file: D001R004  
Extracting Raster Header Records...  
Evaluating Raster Header Records...

srcdocid: sun1  
dstdocid: AFCTN  
txtfilid: W  
figid: 04  
srcgph: tools  
doccls: Unclass  
rtype: 1  
rorient: 000,270  
rpelcnt: 001494,001422  
rdensty: 0230  
\*\*\* ERROR (MIL-R-28002; 3.1.1.2) - Invalid value for 'rdensty:'.  
Expected image density => 200, 240, 300, 400, 600, or 1200.  
notes: Figure 1-4

1 error(s), 0 warning(s), and 0 note(s) were encountered  
in Raster File D001R004.  
Saving Raster Header File: D001R004\_HDR  
Saving Raster Data File: D001R004\_GR4

Found file: D001R005  
Extracting Raster Header Records...  
Evaluating Raster Header Records...

srcdocid: sun1  
dstdocid: AFCTN  
txtfilid: NONE  
\*\*\* ERROR (MIL-STD-1840A; 5.1.4.4) TABLE II - Invalid value for 'txtfilid:'.  
\*\*\* NOTE (MIL-STD-1840A; 5.1.4.4) TABLE II - The value for 'txtfilid:' should  
be 'W' when there is only one text file.  
\*\*\* NOTE - The header record will be given the value W.  
\*\*\* NOTE - Correction made in new %s Header File.  
figid: 0  
srcgph: seal  
doccls: Unclass  
rtype: 1  
rorient: 000,270  
rpelcnt: 001920,001944  
rdensty: 0600  
notes: NONE

1 error(s), 0 warning(s), and 3 note(s) were encountered  
in Raster File D001R005.

---

Saving Raster Header File: D001R005\_HDR  
Saving Raster Data File: D001R005\_GR4

Found file: D001T006  
Extracting Text Header Records...  
Evaluating Text Header Records...

srcdocid: sun1  
dstdocid: AFCTN  
txtfilid: W  
doccls: Unclass  
notes: NONE

Saving Text Header File: D001T006\_HDR  
Saving Text Data File: D001T006\_TXT

Found file: D001G007  
Extracting DTD Header Records...  
Evaluating DTD Header Records...

srcdocid: sun1  
dstdocid: AFCTN  
notes: NONE

Saving DTD Header File: D001G007\_HDR  
Saving DTD Data File: D001G007\_DTD

Evaluating numbering scheme...  
No errors were encountered during numbering scheme evaluation.  
Numbering scheme evaluation complete.

Checking file count...  
No errors were encountered during file count verification.  
File Count verification complete.

A total of 4 error(s), 0 warning(s), and 4 note(s) were  
encountered in Document D001.

A grand total of 4 error(s), 0 warning(s), and 4 note(s) were  
encountered in this File Set.

MIL-STD-1840A File Set Evaluation Complete.

---

## 9.4 Other Tape Reading Logs

No reported errors during the read operation using XSoft  
CAPS read1840A utility.

## 10. Appendix B - Detailed SGML Analysis

### 10.1 Parser Log

IPA0108: \*\*\* SGML Instance Parser Log File \*\*\*  
Source Document File: '9302.txt'.  
Job File: '9302.jbf'.  
DTD File: ''.  
SGML Declaration File: ''.

Reading File '9302.jbf', File Type 'JOB FILE'.

Concrete Syntax Settings In Effect For This Parse:

NAMECASE GENERAL: YES.  
NAMECASE ENTITY: NO.  
NAMELEN: 32.  
SHORTTAG: YES.

Closed '9302.jbf', File Type 'JOB FILE'.

Reading File '9302.txt', File Type 'DIRECT INPUT FILE'.

IPA0143: Unknown Attribute Name: 'SERVICE'.

Error On Line 1.  
State: ''.

IPA0073: REQUIRED Or CURRENT Attribute Is Not Specified: 'BRANCH'.

Error On Line 2.  
State: ''.

IPA0066: Unknown Attribute Value: '(null)'.

IPA0020: Invalid Or Missing Tag. Last Tag Encountered: '<SEAL>'.

Error On Line 18.  
State: 'DOC.FRONT.IDINFO'.

IPA0054: Unknown Attribute In General Entity Name 'seal'.

Error On Line 18.  
State: 'DOC.FRONT.IDINFO.SEAL'.

IPA0054: Unknown Attribute In General Entity Name 'ASG'.

Error On Line 68.  
State: 'DOC.BODY.CHAPTER.PARA0.FIGURE'.

--> Scanned Up To Line 100 In 9302.txt.  
--> Scanned Up To Line 200 In 9302.txt.

IPA0054: Unknown Attribute In General Entity Name 'ASG-1'.

Error On Line 253.  
State: 'DOC.BODY.CHAPTER.PARA0.FIGURE'.

--> Scanned Up To Line 300 In 9302.txt.  
--> Scanned Up To Line 400 In 9302.txt.

IPA0020: Invalid Or Missing Tag. Last Tag Encountered: '</STEP2>'.

Error On Line 468.  
State: 'DOC.BODY.CHAPTER.PARA0.SUBPARA1.STEP1.STEP2'.

--> Scanned Up To Line 500 In 9302.txt.  
IPA0054: Unknown Attribute In General Entity Name 'pack'.  
Error On Line 567.  
State: 'DOC.BODY.CHAPTER.SECTION.PARA0.SUBPARA1.FIGURE'.  
--> Scanned Up To Line 600 In 9302.txt.  
IPA0054: Unknown Attribute In General Entity Name 'tools'.  
Error On Line 612.  
State: 'DOC.BODY.CHAPTER.SECTION.PARA0.PARA.FIGURE'.  
--> Scanned Up To Line 700 In 9302.txt.  
--> Scanned Up To Line 800 In 9302.txt.  
--> Scanned Up To Line 900 In 9302.txt.  
--> Scanned Up To Line 1000 In 9302.txt.  
--> Scanned Up To Line 1100 In 9302.txt.  
--> Scanned Up To Line 1200 In 9302.txt.  
Closed '9302.txt', File Type 'DIRECT INPUT FILE'.  
Document Parsed With 9 Error(s) And 0 Warning(s).

## 10.2 Exoterica Parser

No reported errors.

## 11. Appendix C - Detailed Raster Analysis

### 11.1 File D001R003

#### 11.1.1 Error Log validg4

density = 130  
path length = 472  
scan lines = 653  
bit format = MSB

error getcode, no match in 12 bits  
s=653 word=50 pos=2596

file = d001r003

### 11.1.2 Output Harvard Graphics 3.0

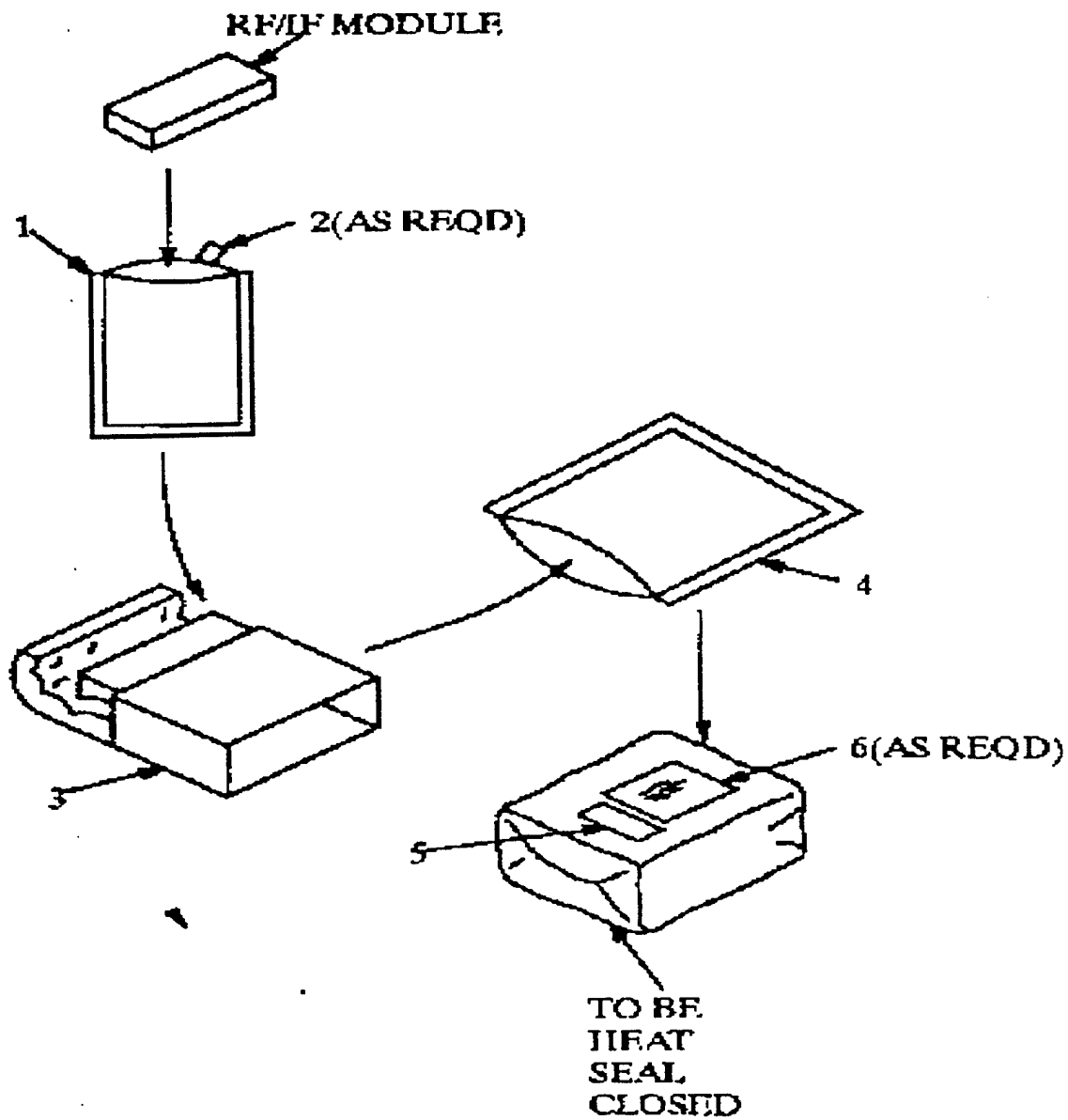

### 11.1.3 Output IGESView

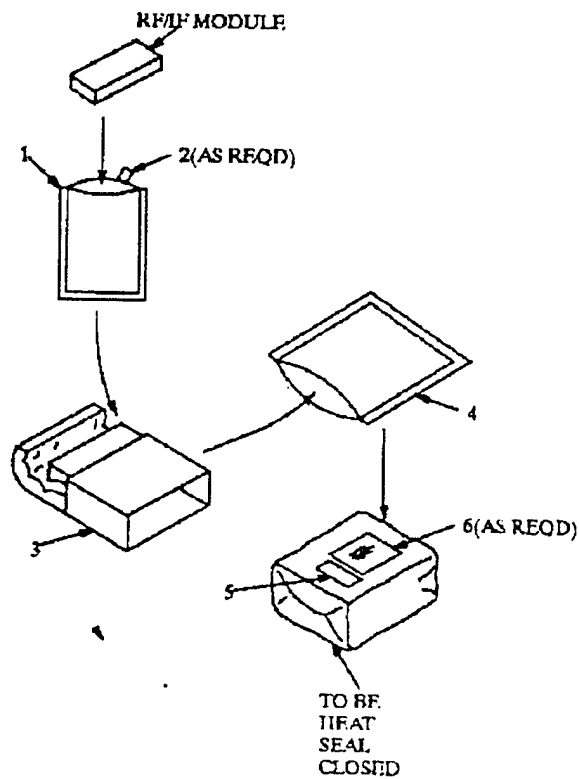

### 11.1.4 Output IslandPaint

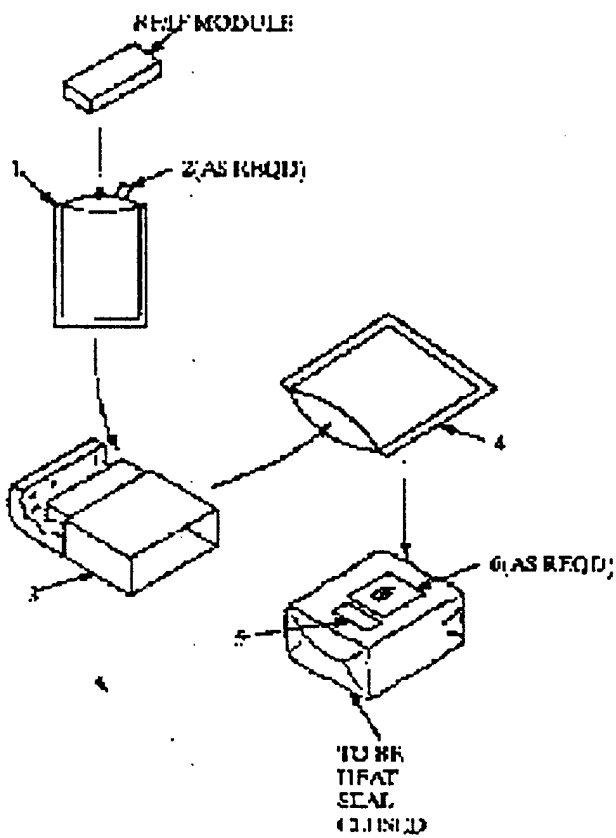

### 11.1.5 Output Preview

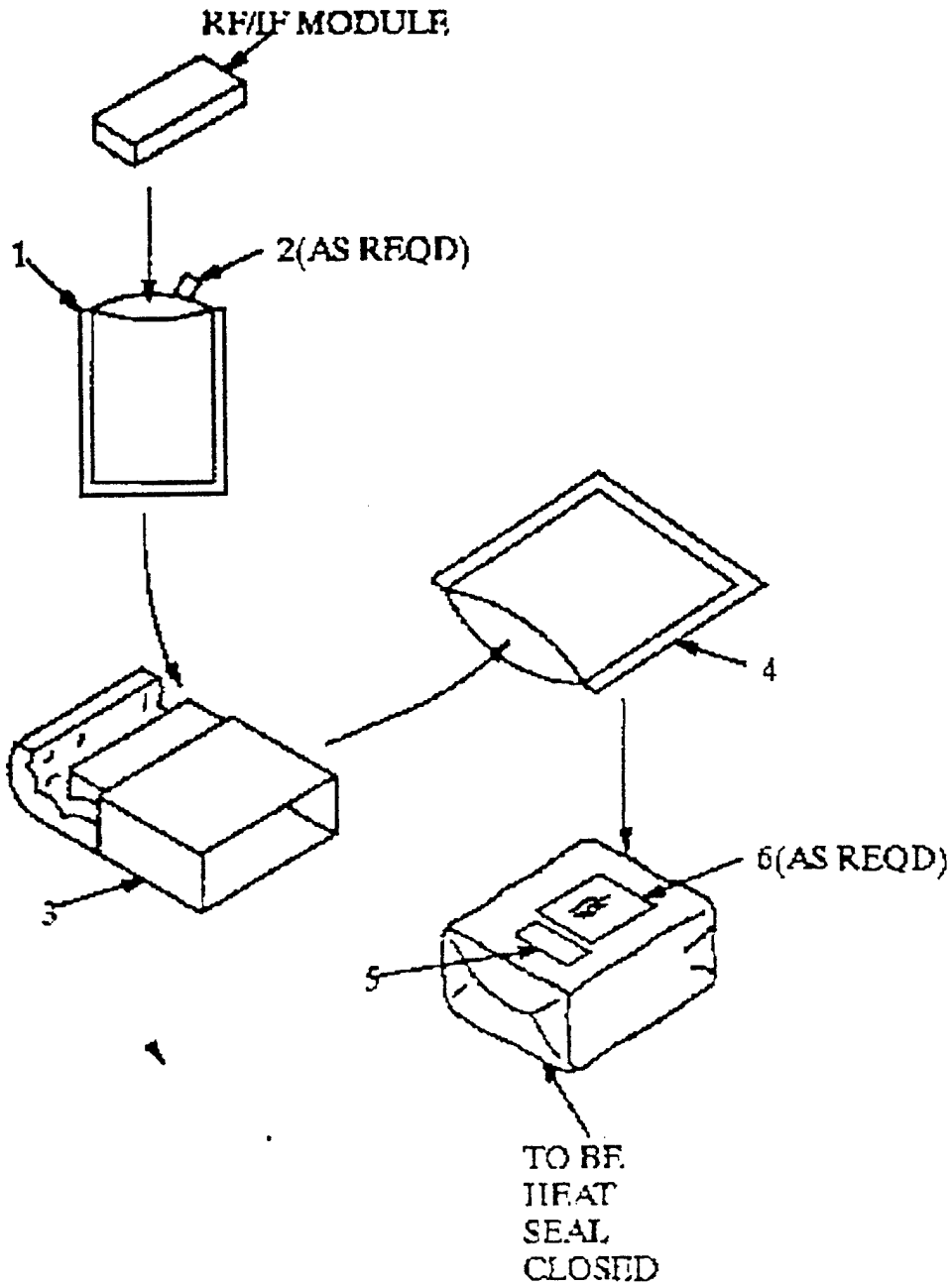

## 11.2 File D001R003

### 11.2.1 Error Log validg4

density = 230  
path length = 1494  
scan lines = 1422  
bit format = MSB

error getcode, no match in 12 bits  
s=1422 word=20 pos=13396

file = d001r004

### 11.2.2 Output Harvard Graphics 3.0

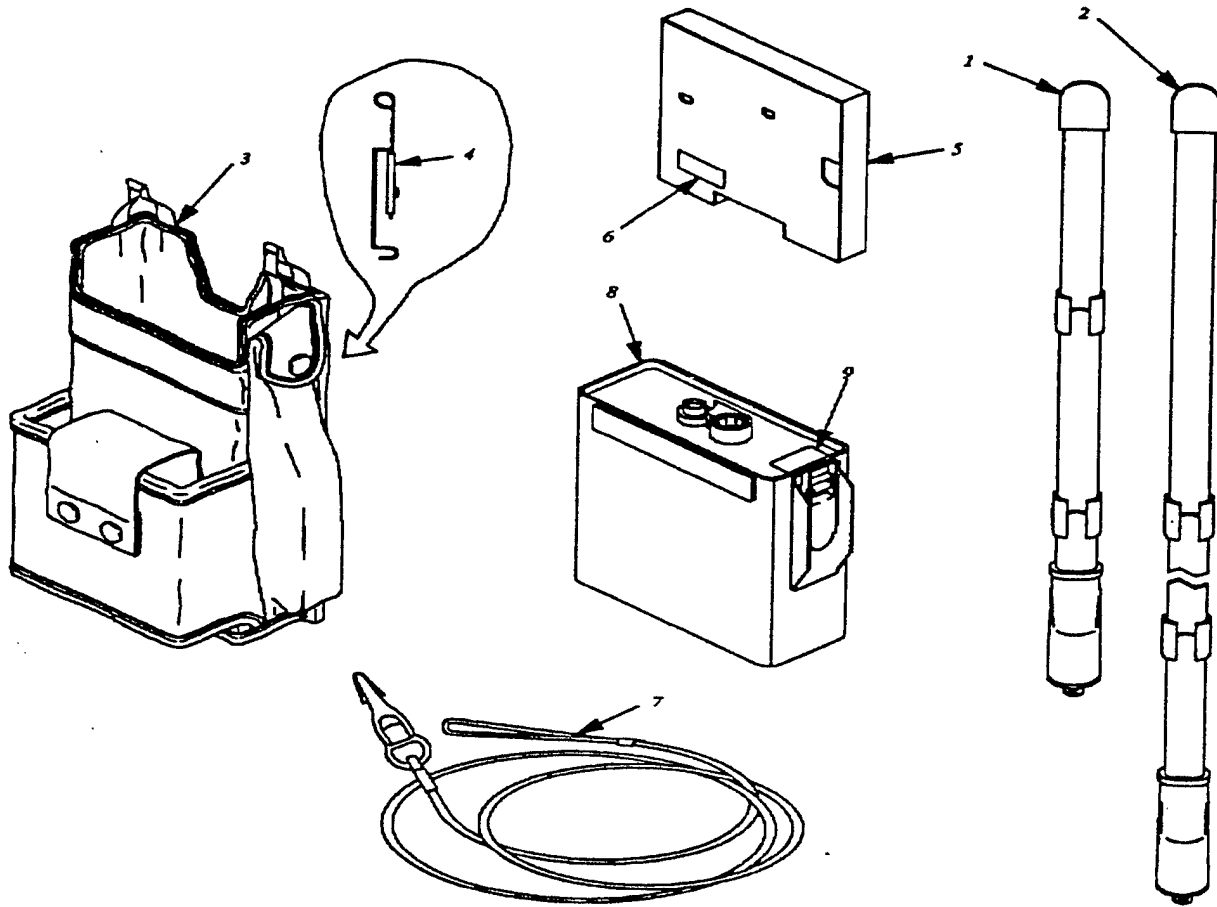

### 11.2.3 Output IGESView

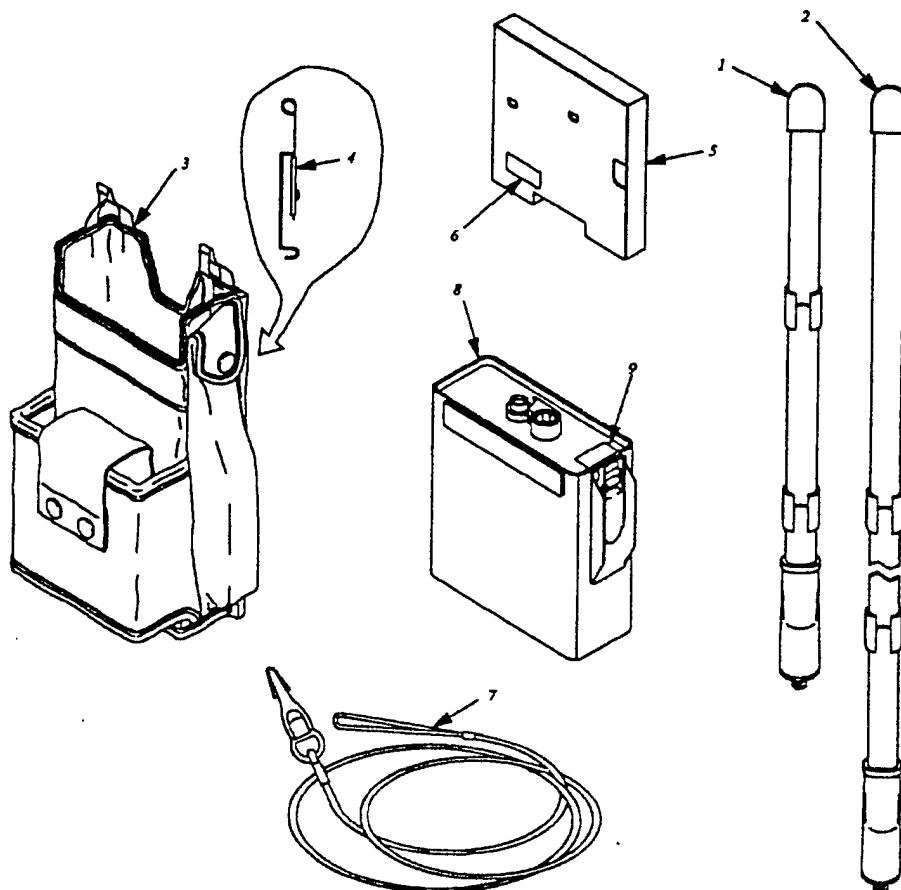

### 11.2.4 Output IslandPaint

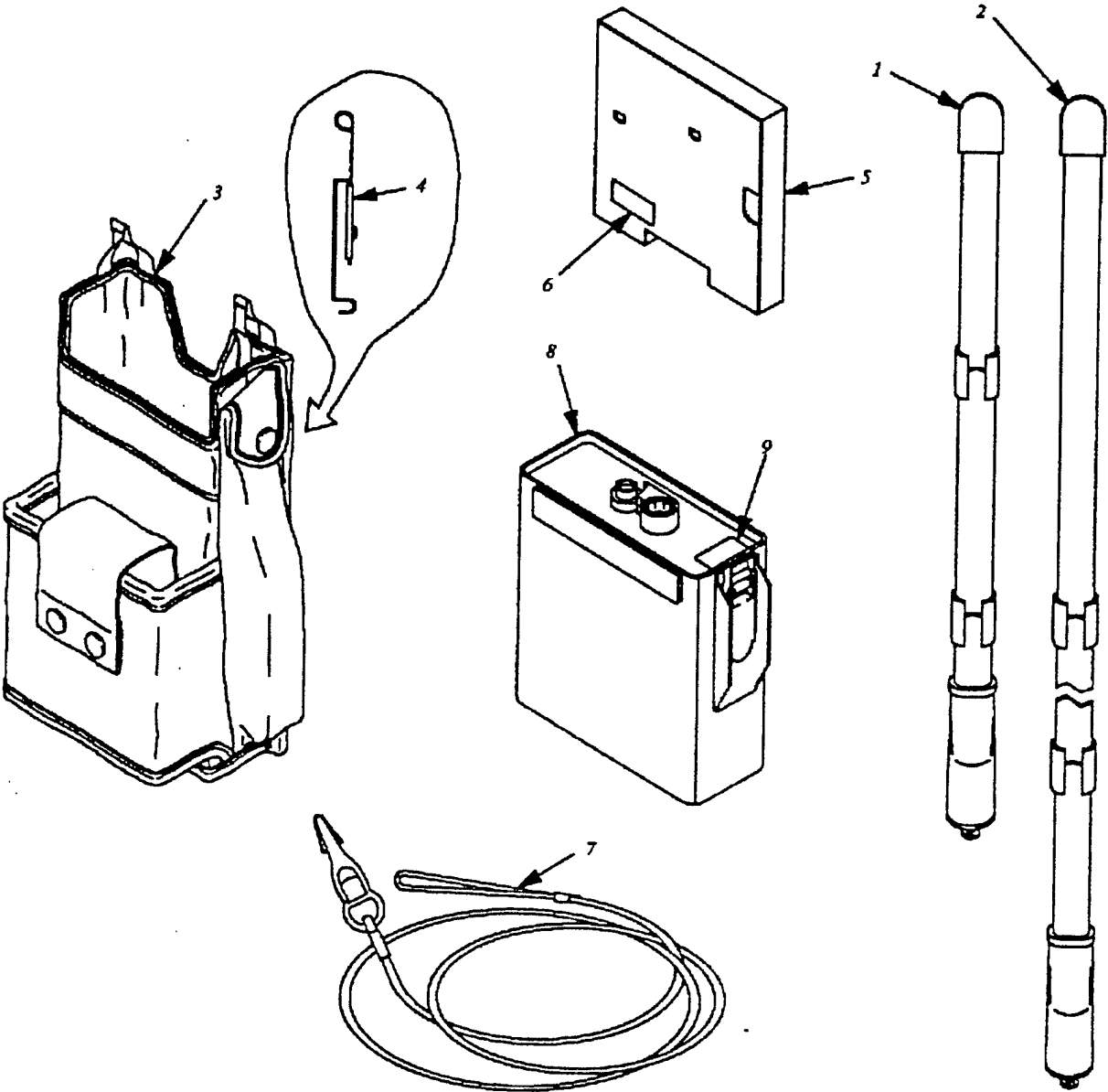

### 11.2.5 Output Preview

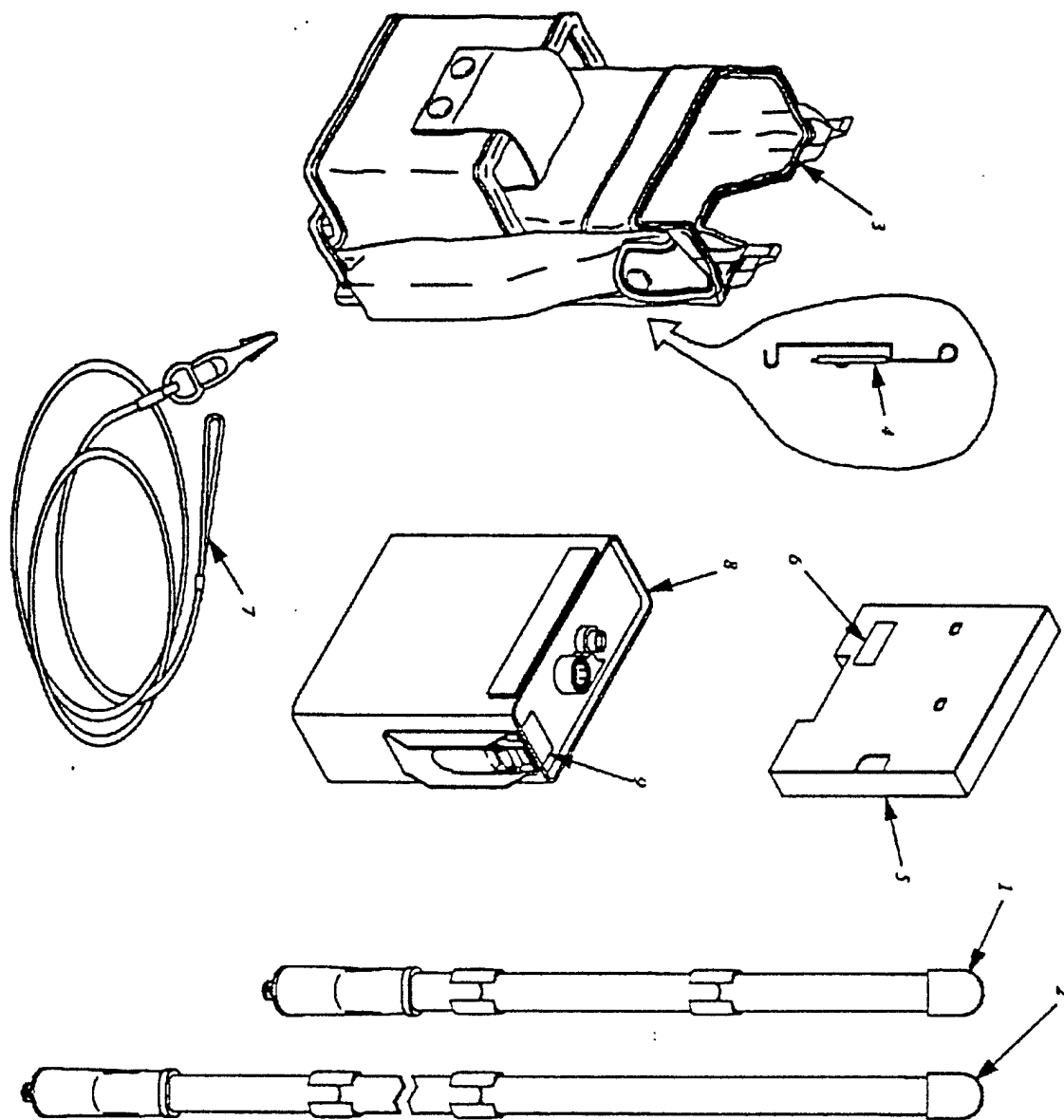

## 11.3 File D001R005

### 11.3.1 Output Harvard Graphics 3.0



### 11.3.2 Output IGESView



### 11.3.3 Output IslandPaint



### 11.3.4 Output Preview



### 11.3.5 Output Ventura Publisher - All Files

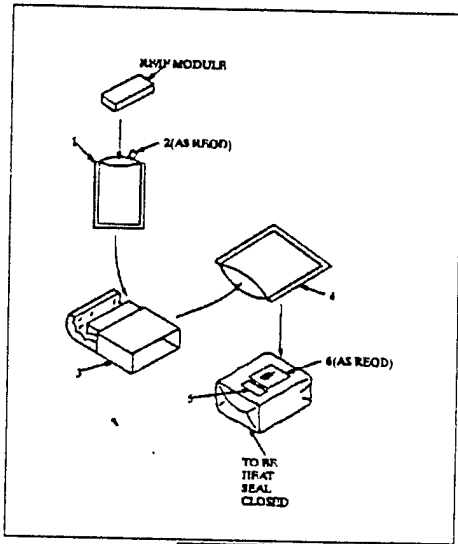

D001R003

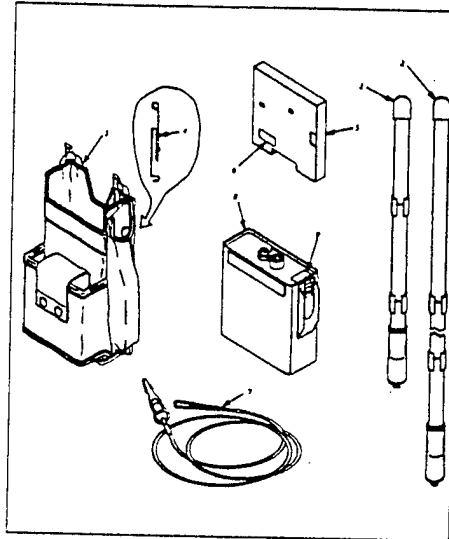

D001R004



D001R005

## 12. Appendix D - Detailed CGM Analysis

### 12.1 File D001C001

#### 12.1.1 Parser Log MetaCheck

MetaCheck Version 2.05 -- CGM/MIL-D-28003 Conformance Analyzer  
Copyright 1988-91 CGM Technology Software  
Execution Date: 01/19/93 Time: 15:42:00

Metafile Examined : \9302\c001

Pictures Examined : All

Elements Examined : All

Bytes Examined : All

=====  
===== Trace Report =====

Tracing not selected.

=====  
===== CGM Conformance Violation Report =====

Bulletin 20002: Element Class/ID: 4/8 Offset: 4634 octets Element No. 328  
Warning; zero area POLYGON SET.

Bulletin 20002: Element Class/ID: 4/8 Offset: 4634 octets Element No. 328  
Warning; zero area POLYGON SET.

Bulletin 20002: Element Class/ID: 4/8 Offset: 4656 octets Element No. 329  
Warning; zero area POLYGON SET.

<<<<< PART OF LOG REMOVED HERE >>>>>

Bulletin 20009: Element Class/ID: 4/1 Offset: 9186 octets Element No. 684  
Warning; POLYLINE with only one distinct vertex.

=====  
===== CALS CGM Profile (MIL-D-28003) Report =====

No profile discrepancies detected.

=====  
===== Conformance Summary Report =====

MetaCheck Version 2.05 -- CGM/MIL-D-28003 Conformance Analyzer  
Copyright 1988-91 CGM Technology Software

---

---

Execution Date: 01/19/93      Time: 15:42:04

Name of CGM under test: \9302\c001.cgm  
Encoding                   : Binary

Pictures Examined       : All  
Elements Examined       : All  
Bytes Examined           : All

BEGIN METAFILE string : "ASG-1.cgm from ASG-1.doc"  
METAFILE DESCRIPTION : "Interleaf Inc. MDL/G CGM 1992 \*\*\*  
                                  MIL-D-28003/BASIC-1"

Picture 1 starts at octet offset 374; string contains: "ASG-1"

Conformance Summary : This file conforms to the CGM specification.

                                  This file meets the CALS CGM Profile (MIL-D-28003).

Summary of Testing Performed and Errors Found:

      1 Pictures Tested  
      687 Elements Tested  
      9222 Octets Tested

0 Illegal CGM Elements	1000 - 1999
0 Incorrect CGM Element Lengths	2000 - 2999
0 CGM State Errors	3000 - 3499
0 Required CGM Elements Missing or Wrong	4000 - 4499
0 CGM Parameter Values Out of Range	6000 - 6499
0 CGM Structure Errors	7000 - 7499
0     ***       CGM Errors Found (total)	***
0 Profile State Errors	3500 - 3999
0 Illegal Profile Elements	4500 - 4999
0 Profile Parameter Values Out of Range	6500 - 6999
0 Profile Data Limits Exceeded	8500 - 8999
0 Other Profile Constraints Violated	9500 - 9999
0     *** Profile Violations Found (total)	***
48 Warnings (Advisory Remarks)	20000 - 20999

2 distinct errors and warnings were reported.

===== End of Conformance Report =====

---

## 12.1.2 validcgm LOG

Analysis for file c001.cgm using table table  
ERROR: invalid times used per CGM (2), std B  
ERROR: invalid times used per Picture (2), std B  
(14, 242) (1, 12, 12) Metafile Defaults Replacement  
ERROR: illegal in this state (2), std B  
ERROR: required precursor (0, 3) not yet seen  
(14.1, 0) (2, 6, 8) VDC Extent (0, 0) (32767, 32767)  
ERROR: invalid times used per CGM (3), std B  
ERROR: invalid times used per Picture (3), std B  
(15, 258) (1, 12, 6) Metafile Defaults Replacement  
ERROR: illegal in this state (2), std B  
ERROR: required precursor (0, 4) not yet seen  
(15.1, 0) (5, 11, 2) Text Precision Stroke  
(0, 1) occurred 1 time  
(0, 2) occurred 1 time  
(0, 3) occurred 1 time  
(0, 4) occurred 1 time  
(0, 5) occurred 1 time  
(1, 1) occurred 1 time  
(1, 2) occurred 1 time  
(1, 3) occurred 1 time  
(1, 4) occurred 1 time  
(1, 5) occurred 1 time  
(1, 6) occurred 1 time  
(1, 7) occurred 1 time  
(1, 8) occurred 1 time  
(1, 9) occurred 1 time  
(1, 10) occurred 1 time  
(1, 11) occurred 1 time  
(1, 12) occurred 3 times  
(1, 12) occurred illegally 2 times  
(1, 13) occurred 1 time  
(1, 15) occurred 1 time  
(2, 1) occurred 1 time  
(2, 2) occurred 1 time  
(2, 3) occurred 1 time  
(2, 4) occurred 1 time  
(2, 5) occurred 1 time  
(2, 6) occurred 2 times  
(2, 6) occurred illegally 1 time  
(2, 7) occurred 1 time  
(3, 1) occurred 1 time  
(4, 1) occurred 369 times  
(4, 5) occurred 13 times

(4, 7) occurred 3 times  
(4, 8) occurred 16 times  
(4, 12) occurred 102 times  
(4, 13) occurred 111 times  
(4, 18) occurred 21 times  
(5, 4) occurred 14 times  
(5, 11) occurred 1 time  
(5, 11) occurred illegally 1 time  
(5, 14) occurred 1 time  
(5, 15) occurred 1 time  
(5, 16) occurred 1 time  
(5, 18) occurred 1 time  
(5, 22) occurred 1 time  
(5, 23) occurred 2 times  
(5, 29) occurred 1 time  
(5, 30) occurred 1 time  
(5, 34) occurred 1 time

### 12.1.3 Output Harvard Graphics

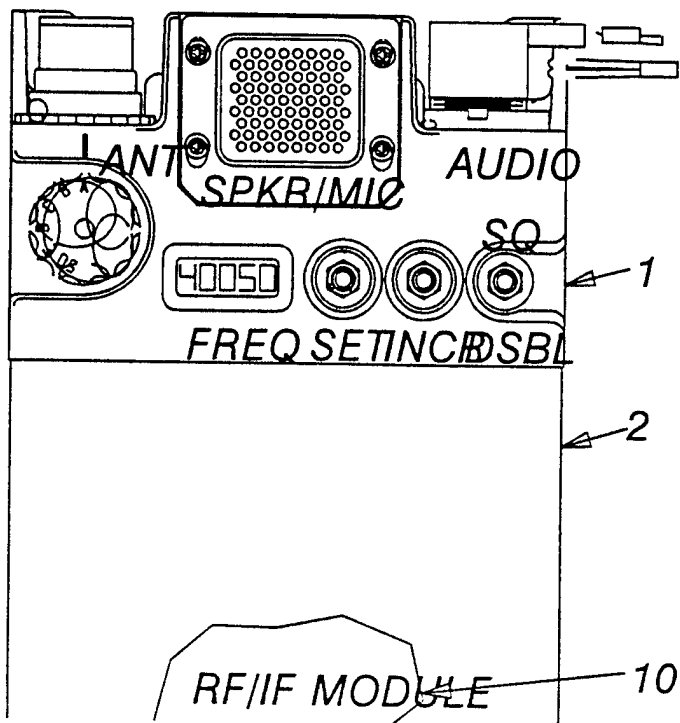

### 12.1.4 Output cgm2draw/IslandDraw

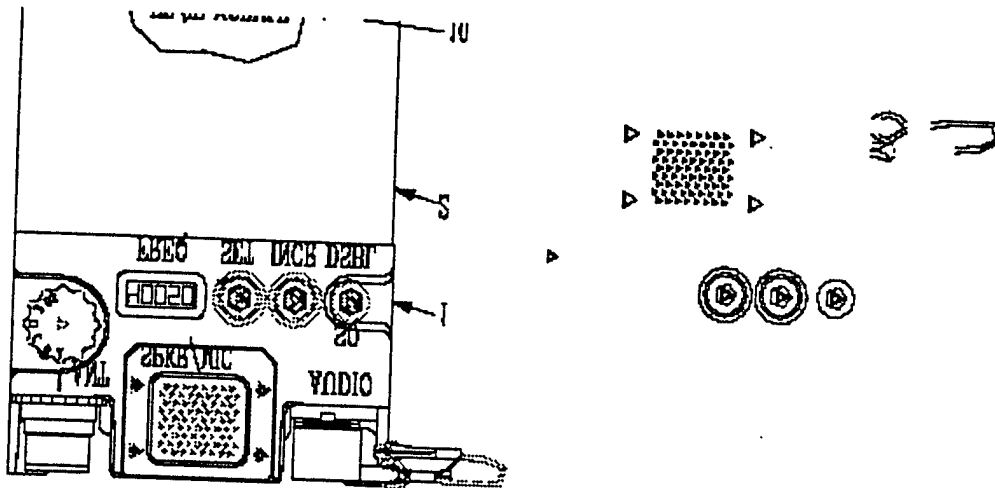

### 12.1.5 Output Island Draw

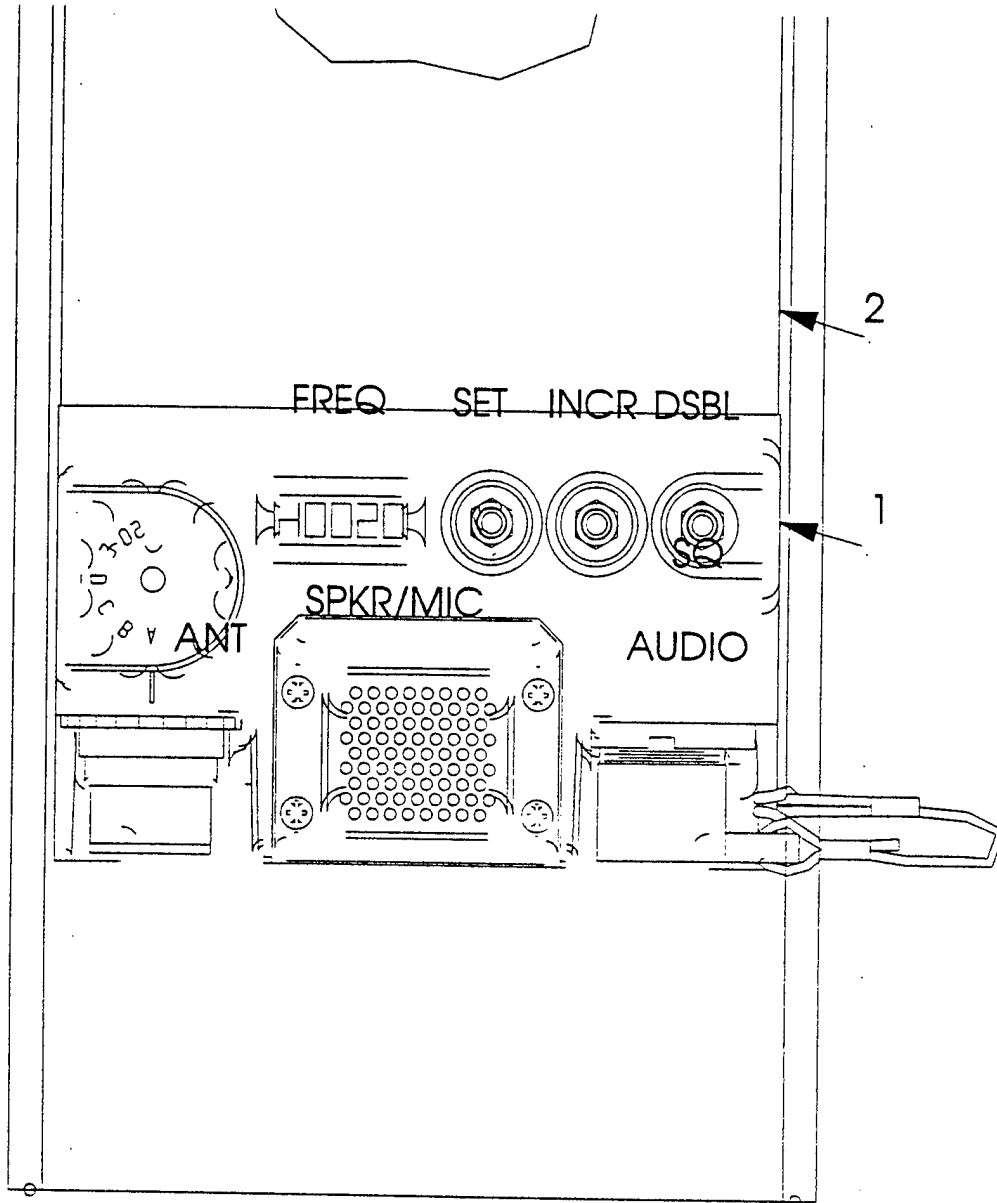

## 12.2 File D001C002

### 12.2.1 Parser Log MetaCheck

MetaCheck Version 2.05 -- CGM/MIL-D-28003 Conformance Analyzer  
Copyright 1988-91 CGM Technology Software  
Execution Date: 01/19/93 Time: 15:42:11

Metafile Examined : \9302\c002

Pictures Examined : All  
Elements Examined : All  
Bytes Examined : All

=====  
===== Trace Report =====

Tracing not selected.

=====  
===== CGM Conformance Violation Report =====

No Errors Detected

=====  
===== CALS CGM Profile (MIL-D-28003) Report =====

No profile discrepancies detected.

=====  
===== Conformance Summary Report =====

MetaCheck Version 2.05 -- CGM/MIL-D-28003 Conformance Analyzer  
Copyright 1988-91 CGM Technology Software  
Execution Date: 01/19/93 Time: 15:42:14

Name of CGM under test: \9302\c002.cgm  
Encoding : Binary

Pictures Examined : All  
Elements Examined : All  
Bytes Examined : All

BEGIN METAFILE string : "Created file ASG\_cgm from ASG\_cgm.sty"  
METAFILE DESCRIPTION : "Interleaf Inc. MDL/G CGM 1992 \*\*\*  
MIL-D-28003/BASIC-1"

Picture 1 starts at octet offset 386; string contains: "ASG"

---

---

Conformance Summary : This file conforms to the CGM specification.

This file meets the CALS CGM Profile (MIL-D-28003).

Summary of Testing Performed and Errors Found:

1 Pictures Tested  
788 Elements Tested  
10042 Octets Tested

```
=====
| No Errors Were Detected |
=====
```

===== End of Conformance Report =====

## 12.2.2 validcgm LOG

Analysis for file c002.cgm using table table  
ERROR: invalid times used per CGM (2), std B  
ERROR: invalid times used per Picture (2), std B  
(14, 254) (1, 12, 12) Metafile Defaults Replacement  
ERROR: illegal in this state (2), std B  
ERROR: required precursor (0, 3) not yet seen  
(14.1, 0) (2, 6, 8) VDC Extent (0, 0) (32767, 32767)  
ERROR: invalid times used per CGM (3), std B  
ERROR: invalid times used per Picture (3), std B  
(15, 270) (1, 12, 6) Metafile Defaults Replacement  
ERROR: illegal in this state (2), std B  
ERROR: required precursor (0, 4) not yet seen  
(15.1, 0) (5, 11, 2) Text Precision Stroke  
(0, 1) occurred 1 time  
(0, 2) occurred 1 time  
(0, 3) occurred 1 time  
(0, 4) occurred 1 time  
(0, 5) occurred 1 time  
(1, 1) occurred 1 time  
(1, 2) occurred 1 time  
(1, 3) occurred 1 time  
(1, 4) occurred 1 time  
(1, 5) occurred 1 time  
(1, 6) occurred 1 time  
(1, 7) occurred 1 time  
(1, 8) occurred 1 time  
(1, 9) occurred 1 time

(1, 10) occurred 1 time  
(1, 11) occurred 1 time  
(1, 12) occurred 3 times  
(1, 12) occurred illegally 2 times  
(1, 13) occurred 1 time  
(1, 15) occurred 1 time  
(2, 1) occurred 1 time  
(2, 2) occurred 1 time  
(2, 3) occurred 1 time  
(2, 4) occurred 1 time  
(2, 5) occurred 1 time  
(2, 6) occurred 2 times  
(2, 6) occurred illegally 1 time  
(2, 7) occurred 1 time  
(3, 1) occurred 1 time  
(4, 1) occurred 628 times  
(4, 4) occurred 10 times  
(4, 7) occurred 8 times  
(4, 12) occurred 6 times  
(4, 13) occurred 72 times  
(4, 17) occurred 7 times  
(4, 18) occurred 10 times  
(5, 3) occurred 1 time  
(5, 4) occurred 1 time  
(5, 11) occurred 1 time  
(5, 11) occurred illegally 1 time  
(5, 14) occurred 1 time  
(5, 15) occurred 1 time  
(5, 16) occurred 1 time  
(5, 18) occurred 1 time  
(5, 22) occurred 2 times  
(5, 23) occurred 3 times  
(5, 28) occurred 1 time  
(5, 29) occurred 1 time  
(5, 30) occurred 5 times  
(5, 34) occurred 1 time

### 12.2.3 Output Harvard Graphics

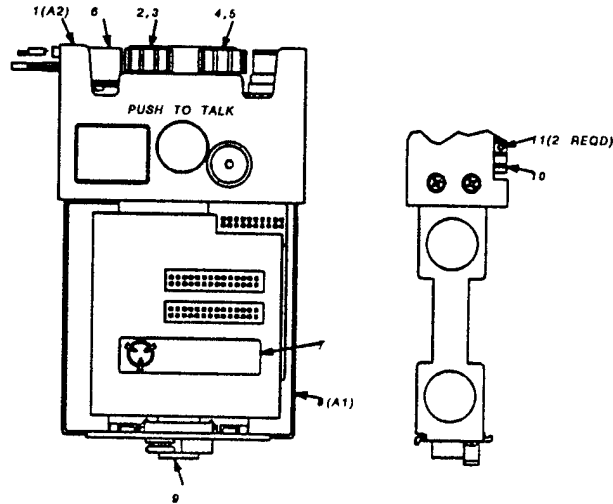

### 12.2.4 Output cgm2draw/IslandDraw

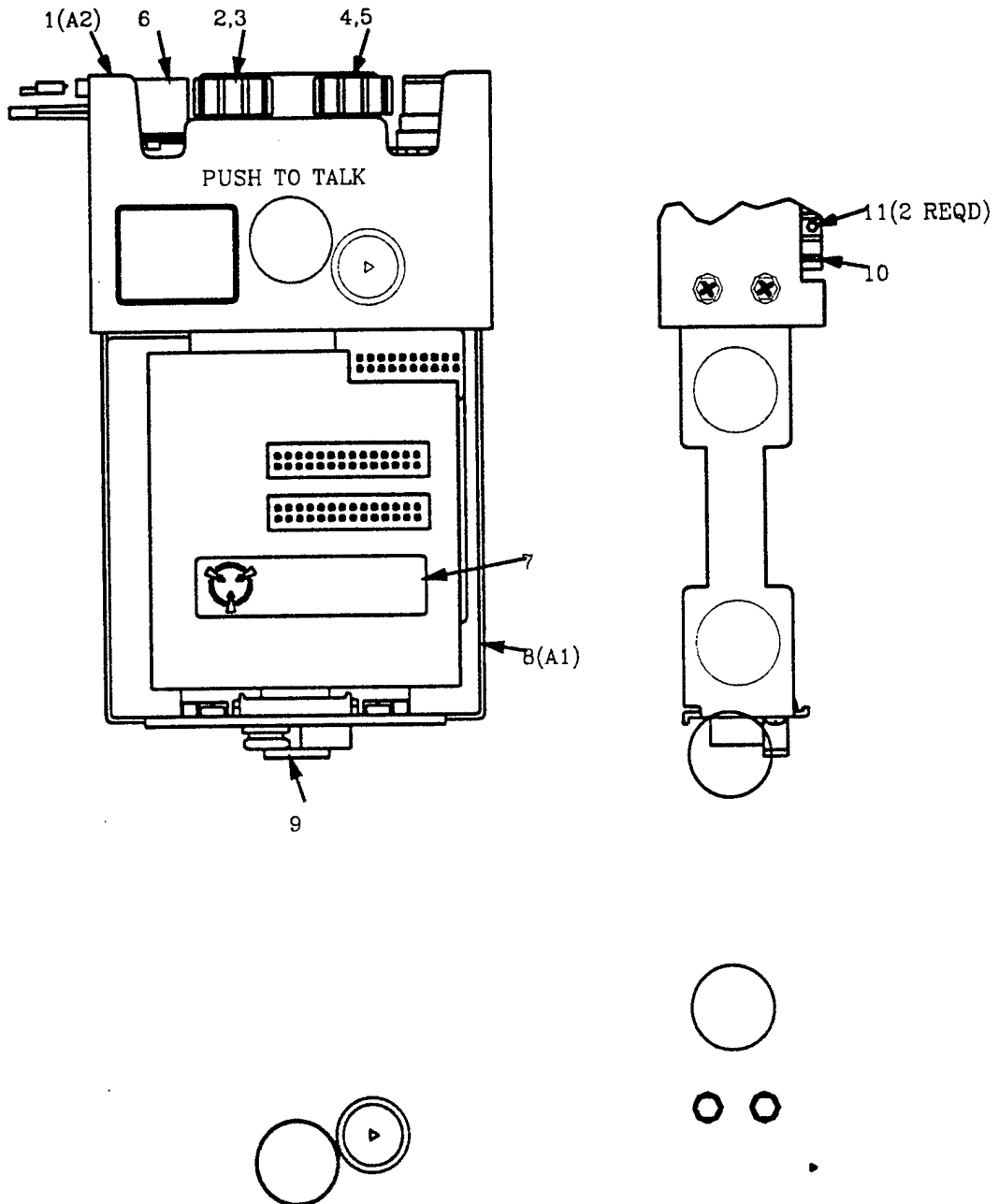

### 12.2.5 Output IslandDraw

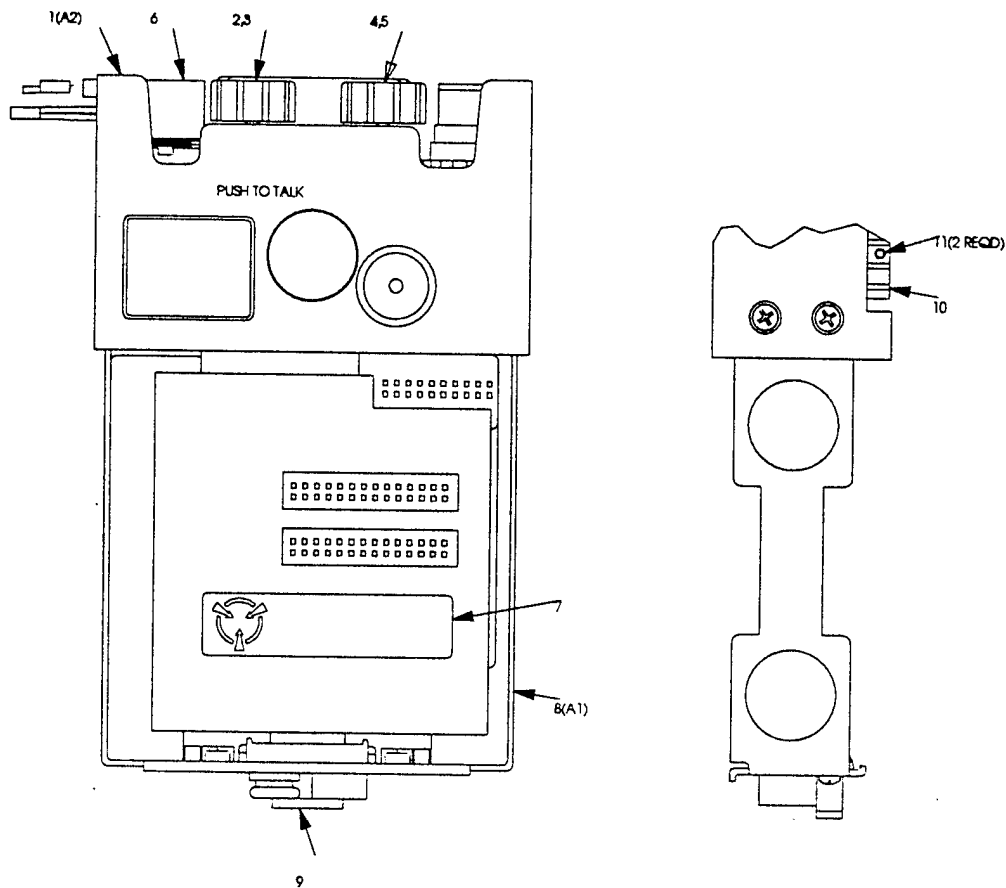

## 12.2.6 Output Ventura Publisher - All Files

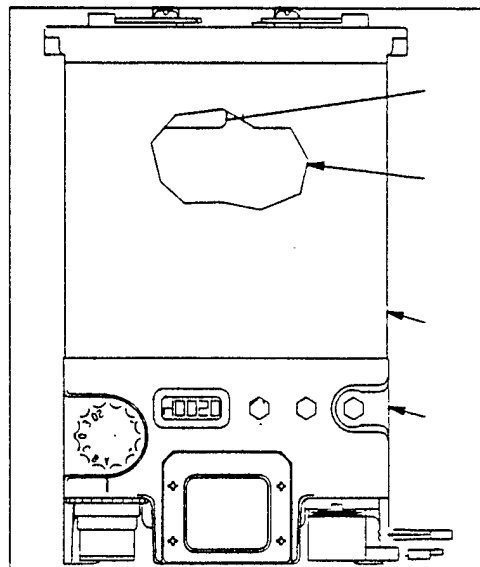

D001C001

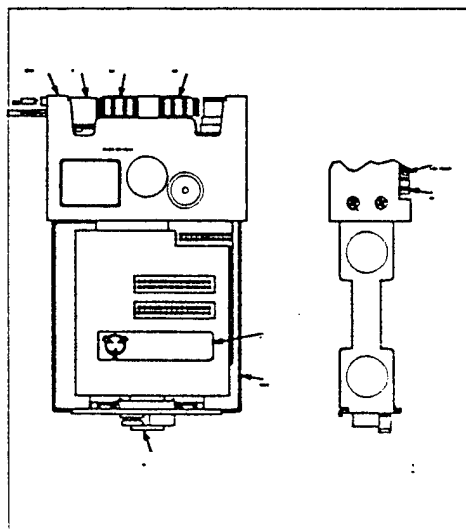

D001C002