

AD \_\_\_\_\_

MIPR: 95MM5586

TITLE: Mechanical Characteristics of the Femoral Intramedullary  
Nailing Systems Available from Five Different Manufacturers

PRINCIPAL INVESTIGATOR: Keith D. Wilkey, MAJ, M.D.  
William Mehserle, M.D.

CONTRACTING ORGANIZATION: Brooke Army Medical Center  
Fort Sam Houston, TX 78234-6200

REPORT DATE: 28 Nov 95

TYPE OF REPORT: Final

PREPARED FOR: U.S. Army Medical Research and Materiel Command  
Fort Detrick, Frederick, Maryland 21702-5012

DISTRIBUTION STATEMENT: Approved for public release;  
distribution unlimited

The views, opinions and/or findings contained in this report are those of the author(s) and should not be construed as an official Department of the Army position, policy or decision unless so designated by other documentation.

19960828 042

# REPORT DOCUMENTATION PAGE

Form Approved  
OMB No. 0704-0188

Public reporting burden for this collection of information is estimated to average 1 hour per response, including the time for reviewing instructions, searching existing data sources, gathering and maintaining the data needed, and completing and reviewing the collection of information. Send comments regarding this burden estimate or any other aspect of this collection of information, including suggestions for reducing this burden, to Washington Headquarters Services, Directorate for Information Operations and Reports, 1215 Jefferson Davis Highway, Suite 1204, Arlington, VA 22202-4302, and to the Office of Management and Budget, Paperwork Reduction Project (0704-0188), Washington, DC 20503.

1. AGENCY USE ONLY (Leave blank)	2. REPORT DATE 28 Nov 95	3. REPORT TYPE AND DATES COVERED Final (9 Jan 95 - 30 Sep 95)	
4. TITLE AND SUBTITLE <b>Mechanical Characteristics of the Femoral Intramedullary Nailing Systems Available from Five Different Manufacturers</b>		5. FUNDING NUMBERS  95MM5586	
6. AUTHOR(S)  Keith D. Wilkey, MAJ, M.D. William Mehserle, M.D.		8. PERFORMING ORGANIZATION REPORT NUMBER	
7. PERFORMING ORGANIZATION NAME(S) AND ADDRESS(ES)  Brooke Army Medical Center Fort Sam Houston, TX 78234-6200		10. SPONSORING/MONITORING AGENCY REPORT NUMBER	
9. SPONSORING/MONITORING AGENCY NAME(S) AND ADDRESS(ES)  Commander U.S. Army Medical Research and Materiel Command, Fort Detrick, Frederick, MD 21702-5012		11. SUPPLEMENTARY NOTES	
12a. DISTRIBUTION / AVAILABILITY STATEMENT  Approved for public release; distribution unlimited		12b. DISTRIBUTION CODE	
13. ABSTRACT (Maximum 200 words)  There are few non proprietary papers addressing the mechanical strength of intramedullary nailing devices; none address the characteristics of the proximal and distal ends of these devices. Independent testing of eight femoral intramedullary nail systems was undertaken at the proximal, middle, and distal regions for rigidity (stiffness) and strength. Each device was a reconstruction nail, 42-46 cm in length. Four or five nails of each size, 10-13 mm diameter, per system were loaded to failure using a four-point bend test. Significant variation was found between systems for strength (yield) and stiffness at the proximal and distal aspects of the rods. A significant difference was observed when comparing the properties of earlier designs with the properties of more recent designs. Mechanical properties did not increase with increasing rod diameter for all systems.			
14. SUBJECT TERMS  Femoral Nails, Mechanical Characteristics		15. NUMBER OF PAGES  44	
17. SECURITY CLASSIFICATION OF REPORT  Unclassified		16. PRICE CODE	
18. SECURITY CLASSIFICATION OF THIS PAGE  Unclassified	19. SECURITY CLASSIFICATION OF ABSTRACT  Unclassified	20. LIMITATION OF ABSTRACT  Unlimited	

## GENERAL INSTRUCTIONS FOR COMPLETING SF 298

The Report Documentation Page (RDP) is used in announcing and cataloging reports. It is important that this information be consistent with the rest of the report, particularly the cover and title page. Instructions for filling in each block of the form follow. It is important to *stay within the lines* to meet *optical scanning requirements*.

**Block 1.** Agency Use Only (Leave blank).

**Block 2.** Report Date. Full publication date including day, month, and year, if available (e.g. 1 Jan 88). Must cite at least the year.

**Block 3.** Type of Report and Dates Covered. State whether report is interim, final, etc. If applicable, enter inclusive report dates (e.g. 10 Jun 87 - 30 Jun 88).

**Block 4.** Title and Subtitle. A title is taken from the part of the report that provides the most meaningful and complete information. When a report is prepared in more than one volume, repeat the primary title, add volume number, and include subtitle for the specific volume. On classified documents enter the title classification in parentheses.

**Block 5.** Funding Numbers. To include contract and grant numbers; may include program element number(s), project number(s), task number(s), and work unit number(s). Use the following labels:

<b>C</b> - Contract	<b>PR</b> - Project
<b>G</b> - Grant	<b>TA</b> - Task
<b>PE</b> - Program Element	<b>WU</b> - Work Unit Accession No.

**Block 6.** Author(s). Name(s) of person(s) responsible for writing the report, performing the research, or credited with the content of the report. If editor or compiler, this should follow the name(s).

**Block 7.** Performing Organization Name(s) and Address(es). Self-explanatory.

**Block 8.** Performing Organization Report Number. Enter the unique alphanumeric report number(s) assigned by the organization performing the report.

**Block 9.** Sponsoring/Monitoring Agency Name(s) and Address(es). Self-explanatory.

**Block 10.** Sponsoring/Monitoring Agency Report Number. (If known)

**Block 11.** Supplementary Notes. Enter information not included elsewhere such as: Prepared in cooperation with...; Trans. of...; To be published in.... When a report is revised, include a statement whether the new report supersedes or supplements the older report.

**Block 12a.** Distribution/Availability Statement. Denotes public availability or limitations. Cite any availability to the public. Enter additional limitations or special markings in all capitals (e.g. NOFORN, REL, ITAR).

**DOD** - See DoDD 5230.24, "Distribution Statements on Technical Documents."

**DOE** - See authorities.

**NASA** - See Handbook NHB 2200.2.

**NTIS** - Leave blank.

**Block 12b.** Distribution Code.

**DOD** - Leave blank.

**DOE** - Enter DOE distribution categories from the Standard Distribution for Unclassified Scientific and Technical Reports.

**NASA** - Leave blank.

**NTIS** - Leave blank.

**Block 13.** Abstract. Include a brief (*Maximum 200 words*) factual summary of the most significant information contained in the report.

**Block 14.** Subject Terms. Keywords or phrases identifying major subjects in the report.

**Block 15.** Number of Pages. Enter the total number of pages.

**Block 16.** Price Code. Enter appropriate price code (*NTIS only*).

**Blocks 17. - 19.** Security Classifications. Self-explanatory. Enter U.S. Security Classification in accordance with U.S. Security Regulations (i.e., UNCLASSIFIED). If form contains classified information, stamp classification on the top and bottom of the page.

**Block 20.** Limitation of Abstract. This block must be completed to assign a limitation to the abstract. Enter either UL (unlimited) or SAR (same as report). An entry in this block is necessary if the abstract is to be limited. If blank, the abstract is assumed to be unlimited.

# DISCLAIMER NOTICE

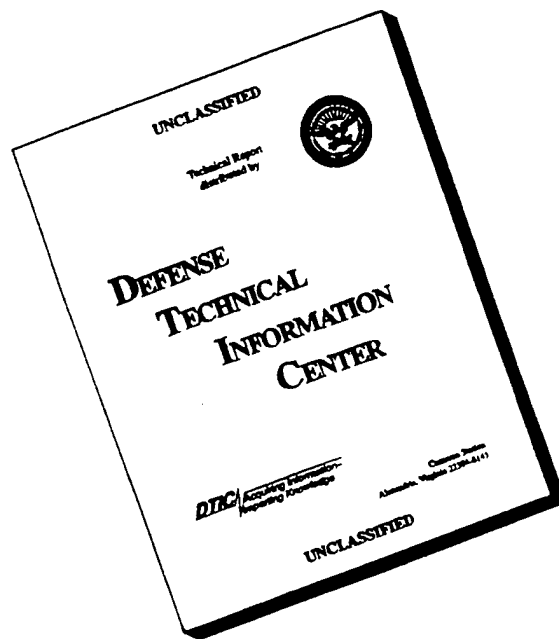

**THIS DOCUMENT IS BEST QUALITY AVAILABLE. THE COPY FURNISHED TO DTIC CONTAINED A SIGNIFICANT NUMBER OF PAGES WHICH DO NOT REPRODUCE LEGIBLY.**

## FOREWORD

Opinions, interpretations, conclusions and recommendations are those of the author and are not necessarily endorsed by the US Army.

Where copyrighted material is quoted, permission has been obtained to use such material.

Where material from documents designated for limited distribution is quoted, permission has been obtained to use the material.

✓ Citations of commercial organizations and trade names in this report do not constitute an official Department of Army endorsement or approval of the products or services of these organizations.

In conducting research using animals, the investigator(s) adhered to the "Guide for the Care and Use of Laboratory Animals," prepared by the Committee on Care and Use of Laboratory Animals of the Institute of Laboratory Resources, National Research Council (NIH Publication No. 86-23, Revised 1985).

For the protection of human subjects, the investigator(s) adhered to policies of applicable Federal Law 45 CFR 46.

In conducting research utilizing recombinant DNA technology, the investigator(s) adhered to current guidelines promulgated by the National Institutes of Health.

In the conduct of research utilizing recombinant DNA, the investigator(s) adhered to the NIH Guidelines for Research Involving Recombinant DNA Molecules.

In the conduct of research involving hazardous organisms, the investigator(s) adhered to the CDC-NIH Guide for Biosafety in Microbiological and Biomedical Laboratories.

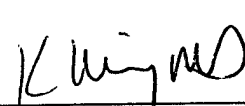
  
Principal Investigator's Signature

11/28/95  
Date

## TABLE OF CONTENTS

Cover	i
Report Documentation Page	ii
Foreword	1
Table of Contents	2
Abstract	3
Introduction	4
Materials and Methods	5
Results	7
Discussion	9
References	15
Tables	17
Figures	24
Appendix	31

## ABSTRACT

There are few non-proprietary papers addressing the mechanical strength of intramedullary nails; none address the characteristics of the proximal and distal ends of these devices.

Independent testing of eight femoral intramedullary nail systems was undertaken at the proximal, middle, and distal regions for strength and flexural rigidity (stiffness).

Each device, usually a reconstruction nail, was 42-46 cm in length. Four or five nails of each available size (range 9-13 mm diameter) were tested for each system. The nails were cut into proximal, middle, and distal thirds. Each nail section was loaded to failure using a four-point bend test on a custom fixture (modification of the American Society of Testing Materials standard test). Significant variations ( $p$ -values  $< 0.05$ ) were found for strength and stiffness between the middle and the proximal or distal aspects of some rods. A significant difference ( $p$ -value  $< 0.05$ ) was observed when comparing the properties of earlier designs with the properties of more recent designs. Newer rod designs all performed in a similar manner with regard to strength. Strength and rigidity increased with increasing rod diameter in some, but not in all systems.

Although none of the newer designs appeared to have superior static strength, the individual systems had significant variations in their mechanical properties (bending rigidity), particularly at the proximal and distal sections. It is important that the surgeon become familiar with the individual characteristics of strength and rigidity for the particular devices available and how these might impact upon fracture healing. Consideration of this data could alter the decision to select one system over another in a complex fracture situation.

## INTRODUCTION

The mechanical characteristics of a nailing system include its static strength, bending rigidity, and its fatigue properties. Current available data for static mechanical properties are proprietary studies that examine these factors using a four-point bend test outlined by the American Society of Testing Materials standard (ASTM) on IM rod testing, ASTM F: 383-73<sup>1</sup>. All currently available studies examine the central portion of the nail while avoiding the proximal and distal ends<sup>6,7,12</sup>.

This testing is not adequate because the nail is not a uniform device; the ends have been altered and are filled with notches, screw threads and holes that must be included for fixation. These loci, and specifically the proximal of the two distal locking screw hole sites, have been clinically more likely to fail than the central area<sup>2,5,14</sup>. Furthermore, earlier work done by Russell<sup>12</sup> has determined that the central third of most available implants are designed and composed of materials that have similar rigidity and strength.

In a tertiary care referral center, it is not uncommon to see a previously nailed high energy femur fracture complicated by femoral nail implant failure. Reports by Bucholz<sup>2</sup>, Chi-Chuan<sup>4</sup>, Franklin<sup>5</sup>, and others, have noted that failure of these devices usually occurs in the proximal and distal sections, not in the middle third. Because this clinical phenomenon could be explained if there were differences in the mechanical properties of proximal and distal regions, analysis at these loci is critical. In this study, testing of eight femoral intramedullary locking nail systems was undertaken in the proximal, middle, and distal regions for strength and rigidity.

## MATERIALS AND METHODS

Eight femoral intramedullary nailing systems that could be used for complex proximal femur fractures, usually a reconstruction nail, were investigated in this study (Table 1). Each device was 42-46 cm in length. Four or five nails (five from the four donated systems and four for purchased systems) of each available size between ten and thirteen millimeters in diameter, were evaluated for each system. During the test period, the titanium unreamed had no 13 mm size, therefore testing began with the 9 mm size. Also, the CFX was available for testing in the 11 and 13 mm sizes only.

Nails were tested in sequence by increasing diameter. Nails within a particular diameter (size) were randomly assigned to a test order sequence after proper labeling. All testing assistants were blinded to the manufacturer of the device during preparation and testing. To facilitate fixturing of the specimen, each IM rod was sectioned in a standardized manner. A band saw with an abrasion blade immersed in an oil-immersion bath sectioned each nail with two cuts. The cuts were made 12.5 cm from either end, resulting in 12.5 cm "proximal" and "distal" segments and a "middle" segment of 17 to 21 cm. These cuts allowed a minimum length of five mm from the cut to the test zone of each segment.

The load test configuration was based on the ASTM standard for testing intramedullary rods<sup>1</sup>. Each specimen was loaded to failure using a four-point bend test on a custom fixture (Figure 1). The fixture consists of two roller-type supports, 11.4 cm apart, with two loading points through rollers located at 3.8 cm and 7.6 cm from the left support. Segments were placed in the fixture with the center of the fixture aligned with the distal locking screw hole for the

proximal section, the midpoint of the middle section, and the proximal locking hole for the distal section. In all tests, the load was applied such that the curvature of the anterior-posterior bend was further accentuated. An Instron device (Instron Corp., Canton, MA) was used to apply equal loads at the two loading points, at a stroke rate of 10 mm/min. A load-deformation (vertical displacement of the nail at the loading points) curve was plotted by the Instron during testing. The yield point was identified by the Instron software where there was a change in the slope of the curve from the elastic to the plastic regions and the rigidity of the device was calculated as the maximum slope of the elastic region (smoothing was used by the Instron software for this calculation). The test was terminated when plastic deformation of the device exceeded the yield point by four millimeters or fracture of the device occurred. The ASTM standard was modified slightly in that we chose to report strength and rigidity in terms of load instead of moment<sup>1</sup>.

### **Data Analysis**

A three-factor analysis of variance was performed on strength and rigidity data using system, nail size, and nail region as factors. A one-way analysis of variance followed by a Student-Neuman-Kuels test were used to identify statistically significant differences (p-values <0.05) between combinations of factors, as appropriate. For interactions, each combination of system, size, and region was treated as a separate group for the Student-Neuman-Kuels testing. In a similar manner, another three-factor analysis of variance was performed on strength data with factors of design generation, nail size, and nail region.

Statistical analysis between the different systems for each nail size and section resulted in a large volume of significant data. To organize this data into a format that allowed clearer comparisons, further analysis was limited to the 11 and 13 mm sizes only and the statistical technique of hierarchical cluster analysis was utilized. Hierarchical Cluster Analysis groups together those systems with similar characteristics (i.e. strength and rigidity) and also shows the relative differences between these groups. The hierarchical cluster analysis results were condensed into tabular form by reporting only the major differences between cluster groups<sup>10</sup>.

To determine the correlation that existed between size and strength, a plot of strength versus size was constructed. Linear regression was used to obtain the slope of this plot. Hierarchical cluster analysis was performed on these slopes to group together those systems with similar strength versus size relationships.

## RESULTS

### Strength and Rigidity Testing

The mean values (over 4 or 5 nails) of strength and rigidity, for all systems, all sizes, all nail sections, are shown in Figures 2 to 7. Statistically significant differences (p-values < 0.05) between the middle section and the proximal or distal sections for strength and rigidity are indicated by a ">" or "<" symbol above the column. The results of the three-factor analyses are reported in Table 2.

The results of the strength and rigidity testing for the middle portion of the nail are presented in Figures 2 and 3, respectively. As expected, most devices had an increasing strength and rigidity with increasing diameter. However, the mean strength value of the 12 mm ZMS

device was 3.6KN less than the 11 mm ZMS device and more flexible by 3570 KN/m ( $p$ -value < 0.05). The small decrements in strength and/or rigidity with size observed in other systems was not statistically significant.

The proximal strength of these devices is shown in Figure 4. The RT, ZMS, and Uniflex systems demonstrated a significantly increased strength in the proximal region, compared to the middle region. The Universal, G-K, Alta, and CFX nails showed no statistically significant differences between proximal and middle region strength. Little variation in proximal strength to size is noted in the RT and Uniflex systems, while the ZMS system shows a decrease in strength with an increase in size from 11 to 12 mm. Differences in proximal strength between the Titanium unreamed 9 and 10 mm sizes and the Uniflex 12 and 13 mm sizes were not statistically significant.

The RT, ZMS, and Uniflex systems had greater rigidity in the proximal section than in the middle section for most of the sizes tested. Some of the other designs had isolated sizes with mean rigidity values that were statistically different between the proximal and the middle sections. Of particular interest is the maximum mean value of nearly 16 KN/m for the ZMS 11 mm nail, and the significant decline in rigidity of the 12 and 13 mm devices. Also, the RT 12 mm device was significantly less rigid than the 11 and 13 mm sizes. This data is presented in Figure 5.

Figures 6 and 7 present the results of strength and rigidity for the distal portion. The distal portion of the nail showed increasing values of strength and rigidity with increasing diameter for most systems tested. Several of the Titanium unreamed and the Uniflex sizes were statistically weaker at their distal ends than in their mid-sections.

A significant trend, observed in the middle portion of the nail, is that nails composed of a stainless steel alloy had less increase in strength, with a similar increase in size, than those composed of a titanium alloy. Slopes of strength versus size for the middle section of all systems are presented in Table 3. Hierarchical Cluster Analysis confirmed a major difference between the stainless steel and the titanium alloy groups (also shown in Table 3).

#### **Comparisons Between Manufacturers - Hierarchical Cluster Analysis**

The analysis for strength (Table 4) demonstrated a major difference between the older and newer designs and that these differences were independent of the section of the nail. The older, simple, tubular stainless steel (Universal and G-K) designs were always in the weakest grouping, by size. The newer designs composed of complex, tubular, stainless steel, and most of the titanium designs, with notable exceptions being the Alta and CFX 11 mm devices, were in the strongest group. Table 4 summarizes this data.

When hierarchical cluster analysis was used to examine the relative differences for rigidity, a much more complex pattern was found. There were differences noted depending on the sections examined (Tables 5, 6, and 7). Devices with reinforced proximal and distal sections were more rigid than simple tubular devices. Also, simple, tubular, stainless steel and titanium designs were more flexible than the designs with complex geometry.

### **DISCUSSION**

The current medical literature contains several articles consisting of case and series reports of femoral nail mechanical failure prior to fracture healing<sup>2,4,5,8,14,16</sup>. Generally, this information concerns older generation nails and has been associated with complex fracture patterns and early

weight bearing. Specifically, the patient at most risk is the one who is weight bearing before fracture healing of his comminuted proximal femur fracture. In this situation, the most proximal of the two distal locking screw holes is at greatest risk for failure.<sup>2</sup> To overcome these problems, the manufacturers of current generation devices have engineered more complex products. Design concepts have tended toward increasing the diameter of the device, "cold working" at the screw hole sites, using closed sectioned devices, and abandoning steel alloys for the stronger and less rigid titanium alloys.

For technical ease during implantation and for cost containment reasons, ideally the same implant design should be used for both simple transverse midshaft femur fractures and complex proximal and distal femur fractures. For these complex fractures, there is concern that some currently available femoral intramedullary nailing systems are resulting in implantation of a more rigid or, potentially worse, a weaker device in the area of concern. Also, there are conflicting claims from competing manufacturers regarding the mechanical characteristics of their devices. To our knowledge, there have not been any published independent studies comparing the strength, stiffness, and fatigue of these newer generation femoral nails. More worrisome is the lack of any study comparing these devices in the critical proximal and distal sections. Also, data regarding variations in mechanical characteristics of the device with respect to the diameter are limited. There have been few case series and one randomized clinical study demonstrating the clinical efficacy of some of these devices<sup>3,13</sup>. This study presents the static mechanical properties, strength and rigidity, of the devices tested.

Compared to the mid-region, our data has clearly shown that there are statistically significant differences in the strength and rigidity between the middle and the proximal and distal sections of some devices. Obviously, a stronger device is more desirable than a weaker one as this characteristic is more closely related to durability and fatigue than any other<sup>9</sup>. The rigidity of the design is also important. Flexibility is necessary to allow the nail to be inserted without damaging the femur and allow stress transfer to the bone during healing. If the device is too rigid (more rigid than the femur), however, alterations in fracture repair and resorption of the surrounding bone can result. These changes have been implicated in delays in healing<sup>11</sup>. This delay in healing causes the implant to be loaded for a longer period of time, resulting in device failure, either from fatigue or because it is stressed beyond its ultimate strength, prior to fracture healing. The problem is that the rigidity tends to increase at a rate greater than the strength of the device. This phenomenon might explain why the designs with reinforced proximal section and distal sections still fail in these regions. The optimum value of these two opposing characteristics has yet to be determined and computer assisted design models are currently being undertaken to aid in the optimization of these parameters.

The results of size versus strength (reference Figures 2-7) for stainless steel as a group and titanium as a group would indicate that a surgeon using a stainless steel design might be able to easily justify not "reaming up" to a larger sized nail; there is less of an increase in strength of these devices with size than their titanium alloy counterparts. Clearly, if the surgeon is using a titanium system, and particularly those with the weak smaller size (Alta and CFX) the converse of this concept would be applicable. Although the rigidity of the largest diameter titanium devices is

usually below that of the newer generation stainless steel counterparts, the data also shows that the rigidity of these designs usually increases rapidly with increasing diameter. The surgeon may feel that the added advantage of strength does not outweigh the disadvantage of increased rigidity. One exception to this is the Titanium unreamed design from Synthes. Its strength increases more rapidly than its rigidity as size increases. The 12 mm size nail is significantly stronger and yet more flexible than the 12 mm nails of other manufacturers. Another exception is the ZMS system. There is a 4450 KN/m increase in the middle section rigidity from the 10 to 11 mm size. To overcome an excessively rigid 12 mm size, a switch to a slotted less rigid design was made for the 12 and 13 mm sizes. This is why the 12 mm size is less strong and rigid than the 11 mm size.

Due to the large volume of statistically significant data obtained while making comparisons between different manufacturers' devices, hierarchical cluster analysis was used to organize this information into a useable format. The results of the three-factor analysis comparing the older and newer designs and the dendrograms produced by this analysis on strength data showed that there existed a major difference between older, simple, stainless steel and the newer complex, stainless steel and titanium designs. The clinical case series on implant failure involves these older designs. There is a notable absence in the literature for reporting similar implant failure for the newer designs. This finding would suggest that the newer and statistically stronger designs have improved beyond a baseline failure threshold for routine fracture management. In short, when comparing the relative differences between manufacturers' designs, the data presented

here does not indicate that any one of the new rod designs will perform in a superior manner with regard to strength than any of the other new designs.

As for rigidity, the complex behavior of this mechanical characteristic makes conclusions difficult. However, devices that were reinforced at the proximal and distal ends (R-T, ZMS, and Uniflex) were consistently more rigid than the simple designs (Universal, Ti unreamed, Alta, G-K, and CFX). As noted above, a device with rigidity nearer to that of the femur is thought to be more desirable. Therefore, consideration should be made for the unique rigidity of the chosen system during preoperative planning, particularly with a complex proximal or distal femur fracture.

A custom fixturing apparatus was required to hold the test specimen securely and apply the load in a consistent manner. The resulting standard deviations were small enough to allow statistical comparisons between size, region, system, and generation. Also, data regarding the strength and rigidity of the middle sections of two manufacturer's femoral nails was available prior to our study<sup>6,7</sup>. These proprietary papers reported their results in terms of load instead of moment, thus altering the ASTM standard slightly. In order to allow comparisons between their data and our own, we chose to report our data in a similar manner. Lastly, we recognize that most intramedullary femoral nails fail in fatigue, with a rare exception being a second major injury resulting in a large force being applied to an already fatigued device. As strength testing is the best static test to approximate fatigue testing, valuable information can be gained from this data<sup>9</sup>.

This research would agree with Winquist, that with the noted exceptions, the difference in the static strength among newer designs of intramedullary locking femoral nails is minimal<sup>15</sup>.

However, individual systems have significant variations in their mechanical properties (bending rigidity), particularly at the proximal and distal sections. No single locking intramedullary femoral nailing system can be recommended for all femur fractures. Along with the knowledge of the interplay of implant mechanical properties and its impact upon fracture healing, a surgeon confronted with a complex femur fracture can utilize the data presented in this study to select the system that will work best for this particular challenging fracture.

## REFERENCES

1. American Society for Testing and Materials (1987), Annual Book of ASTM Standards Section 13 Medical Devices: PCN: 01-130187-54 87-88, Philadelphia.
2. Bucholz, R.; Ross, S.; and Lawrence, K.: Fatigue fracture of the interlocking nail in the treatment of fractures of the distal part of the femoral shaft. *J. Bone and Joint Surg.*, 71-A: 336-340, 1987.
3. Cameron, C.; Meek, R.; Blachut, P.; O'Brien, P.; and Pate, G.: Intramedullary nailing of the femoral shaft: A prospective, randomized study. *J. Orthop. Trauma*, 6(4):448-451, 1992.
4. Chi-Chuan, W.; and Chun-Hsiung, S.: Biomechanical analysis of the mechanism of interlocking nail failure. *Arch. Orthop. Trauma Surg.*, 11(5):268-272, 1992.
5. Franklin, J.; Winqvist R.; Benirschke, S.; and Hansen, S.: Broken intramedullary nails. *J. Bone and Joint Surg.*, 70A(10):1463-1471, 1988.
6. Levy, M.S.[letter author]: Testing of the Alta Rod System. Howamedica U.S.A., Pfizer Hospital Products Group, 359 Veterans Boulevard, Rutherford, N.J. Response to Inquiry Letter, February 1994.
7. McKellop, H.A.; Ebramzadeh, E.; Park, S.H.; Wiss, D.; Brien, W.; and Grover, J.S.: Development and clinical performance of a reversible titanium alloy femoral interlocking nail. A Scientific Exhibit, American Academy of Orthopaedic Surgeons, 58th Annual Meeting, Anaheim, California, March 1991.
8. Meislin, R.; Frankel, V.; Kummer, F.: Intramedullary nailing of subtrochanteric fractures: A critical review of device failure and case analysis. *Bulletin Hospital for Joint Diseases*, 52(2): 17-20, 1993.

9. Nicolai, L.M.: *Fundamentals of Aircraft Design*, pp19-4 to 19-6. San Jose, METS Inc., 1975.
10. Norusis, M.J.: SPSS/PC+, In *Professional Statistics*, pp. 95-121. Chicago, SPSS Inc., 1992.
11. Rockwood, C. and Green, D: (eds): *Fractures in Adults*, 3rd ed., pp. 199-200. Philadelphia, Lippincott Co., 1991.
12. Russell, T.A.; Taylor, J.; LaVelle, D.; Beals, N.; Brumfield, D.; and Durham, A.: Mechanical characterization of femoral interlocking intramedullary nailing systems. *J. Orthop. Trauma*, 5(3):332-339, 1991.
13. Taylor, J.; Russell, T.A.; LaVelle, D.; and Callandruccio, R.: Clinical results of 100 femoral shaft fractures treated with the Russell-Taylor interlocking nail system. Read at the Annual Meeting of the American Academy of Orthopaedic Surgeons, San Francisco, January 26, 1987.
14. Weinstein, A.; Clemow, A.; Starkebaum, W.; Milicic, M.; Klawiter, J.; and Skinner, H.: Retrieval and analysis of intramedullary rods. *J. Bone and Joint Surg.*, 63-A:1443-1448, 1981.
15. Winqvist, R.: Locking femoral nailing. *J. Am. Academy of Orthop. Surg.*, 1(2):95-105, 1993.
16. Zimmerman, K.; and Klasen, H.: Mechanical failure of intramedullary nails after fracture union. *British J. Bone and Joint Surg.*, 65-B(3):274-275, 1983.

TABLE 1

## Systems Investigated

Manufacturer	System	Source	Design Generation	Material	Design Type	Sizes
Synthes	Universal	Donated	old	stainless steel	simple, tubular	10, 11, 12, 13
Howmedica	Grosse and Kempf (G-K)	Purchased	old	stainless steel	simple, tubular	10, 11, 12, 13
Richards	Russel-Taylor Delta	Purchased	new	stainless steel	complex, tubular	10, 11, 12, 13
Zimmer	Recon and Recon (RT)					
	ZMS	Donated	new	stainless steel	complex, tubular	10, 11, 12, 13
Howmedica	Alta	Purchased	new	titanium	simple, tubular	10, 11, 12, 13
Howmedica	CFX	Purchased	new	titanium	simple, tubular	11, 13
Synthes	Titanium unreamed Solid (Ti unreamed)	Donated	new	titanium	simple, solid	9, 10, 11, 12
Biomet	Uniflex	Donated	new	titanium	complex, tubular	10, 11, 12, 13

TABLE 2  
Three-Factor Analyses

**Factors: System, size, and region**

Source	Significance for Strength	Significance for Rigidity
system	0.000	0.000
size	0.000	0.000
region	0.087	0.000
system by size	0.000	0.000
system by region	0.007	0.000
system by size by region	0.000	0.000

**Factors: Design generation, size and region**

Source	Significance for Strength
design	0.000
size	0.000
region	0.002
design by size	0.66
design by region	0.008
size by region	0.675
design by size by region	0.848

TABLE 3

Slope of Plot - Strength Versus Size/Middle Section

System	Alloy	Slope	Corr.	Sign	HCA grouping
ZMS	stainless	0.23	0.158	0.507	lesser
G-K	stainless	0.55	0.867	0.000	lesser
Universal	stainless	0.65	0.915	0.000	lesser
R-T	stainless	0.78	0.786	0.000	lesser
Ti unreamed	titanium	1.71	0.911	0.000	greater
Uniflex	titanium	1.88	0.886	0.000	greater
CFX	titanium	1.93	0.971	0.000	greater
Alta	titanium	2.54	0.997	0.000	greater

Table 4

## Hierarchical Cluster Analysis

**Strength - Middle, Distal, and Proximal Sections**

11mm - 2 groups

13mm - 3 groups

**Weakest group****Weakest group**

Universal

Universal

G-K

G-K

Alta

**Intermediate group**

CFX

RT

**Strongest group**

ZMS

RT

Alta

ZMS

CFX

Uniflex

**Strongest group**

(Ti unreamed)

Uniflex

**TABLE 5**  
**Hierarchical Cluster Analysis**

**Rigidity - Middle Section**

11mm - 3 groups

**Flexible group**

Universal

Alta

CFX

**Intermediate group**

G-K

Uniflex

(Ti unreamed)

**Rigid group**

RT

ZMS

13mm - 3 groups

**Flexible group**

Universal

G-K

**Intermediate group**

ZMS

Alta

CFX

Uniflex

**Rigid group**

RT

TABLE 6  
Hierarchical Cluster Analysis

**Rigidity - Distal Section**

11mm - 3 groups

**Flexible group**

Universal

Alta

CFX

**Intermediate group**

G-K

Uniflex

(Ti unreamed)

**Rigid group**

RT

ZMS

13mm - 2 groups

**Flexible group**

Universal

G-K

**Rigid group**

RT

ZMS

Alta

CFX

Uniflex

TABLE 7  
Hierarchical Cluster Analysis

**Rigidity - Proximal Section**

11mm - 2 groups

**Flexible group**

Universal

G-K

Alta

CFX

(Ti unreamed)

**Rigid group**

RT

ZMS

Uniflex

13mm - 2 groups

**Flexible group**

Universal

G-K

Alta

CFX

**Rigid group**

RT

ZMS

Uniflex

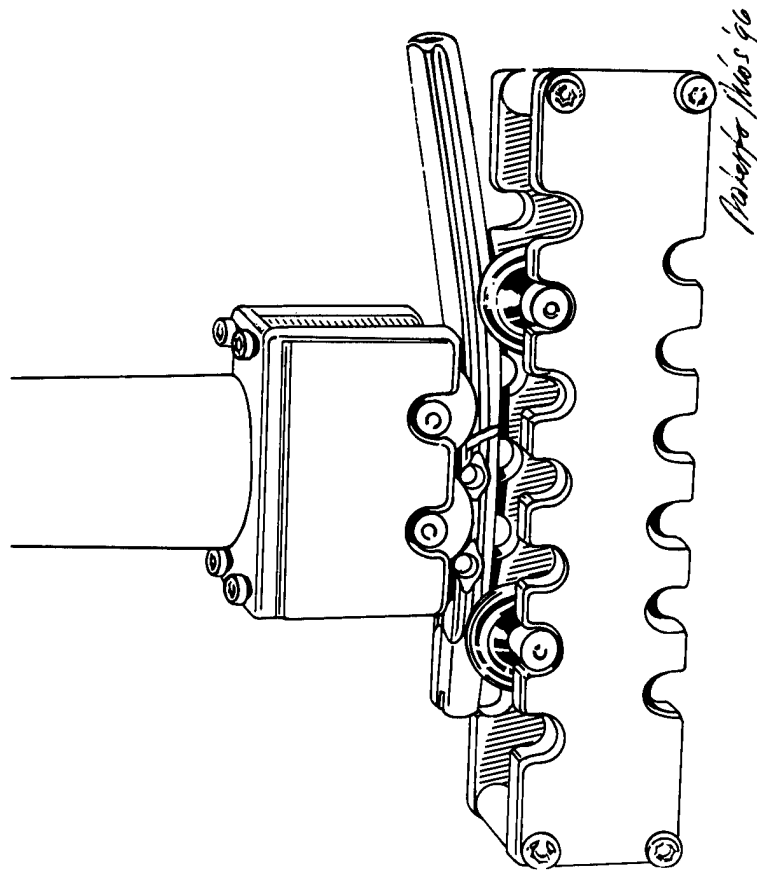

Figure 1: Custom fixture device. Four-point bend test on proximal third section of an Alta nail.

# STRENGTH - MIDDLE

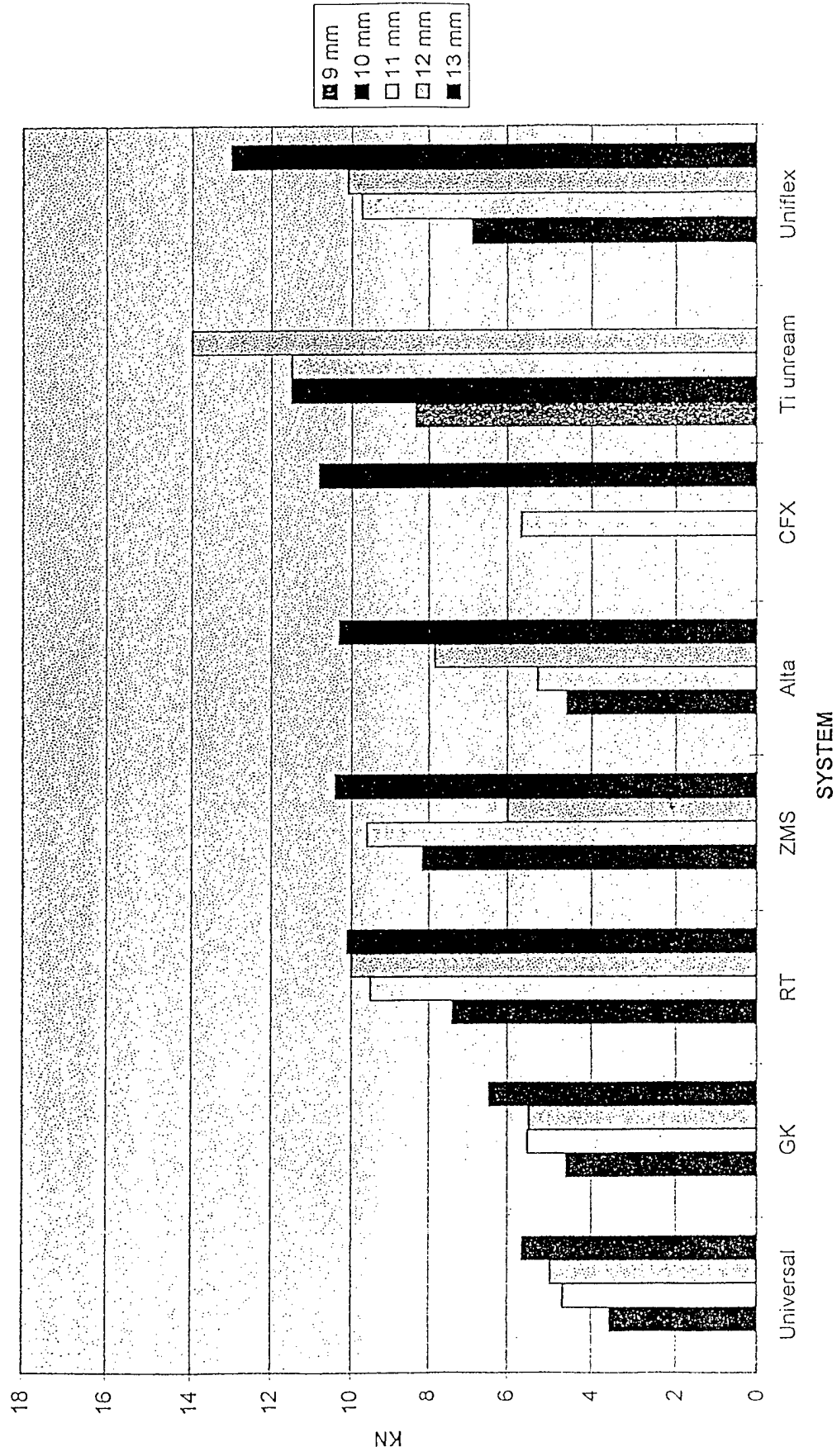

Figure 2: Middle section strength as a function of system and size.

# RIGIDITY - MIDDLE

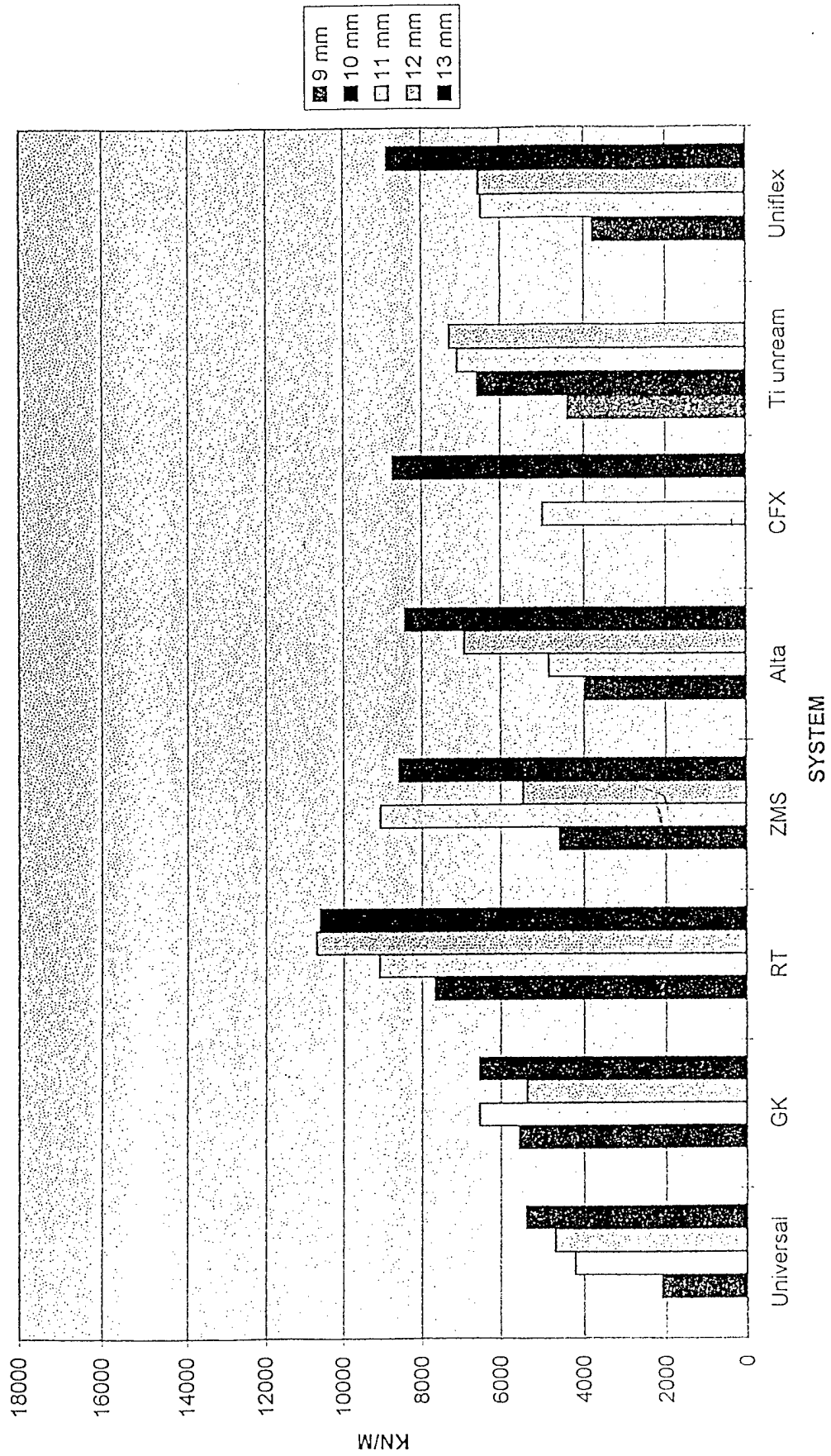

Figure 3: Middle section rigidity as a function of system and size.

# STRENGTH - PROXIMAL

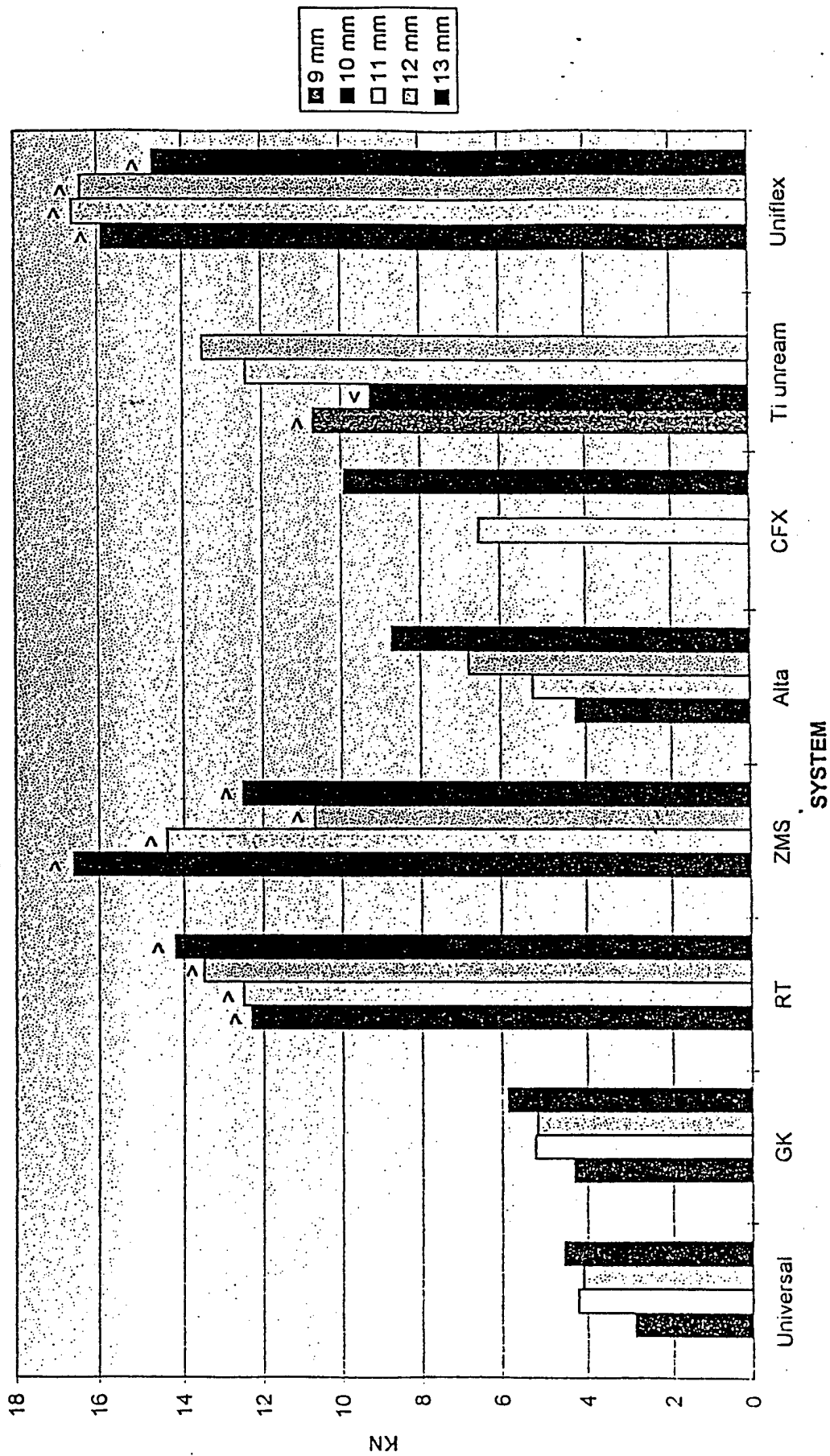

Figure 4: Proximal section strength as a function of system and size. A Character above a bar indicates that a statistically significant difference exists for this section as compared with the middle section. The character also indicates whether the value is greater than or less than the middle section.

# RIGIDITY - PROXIMAL

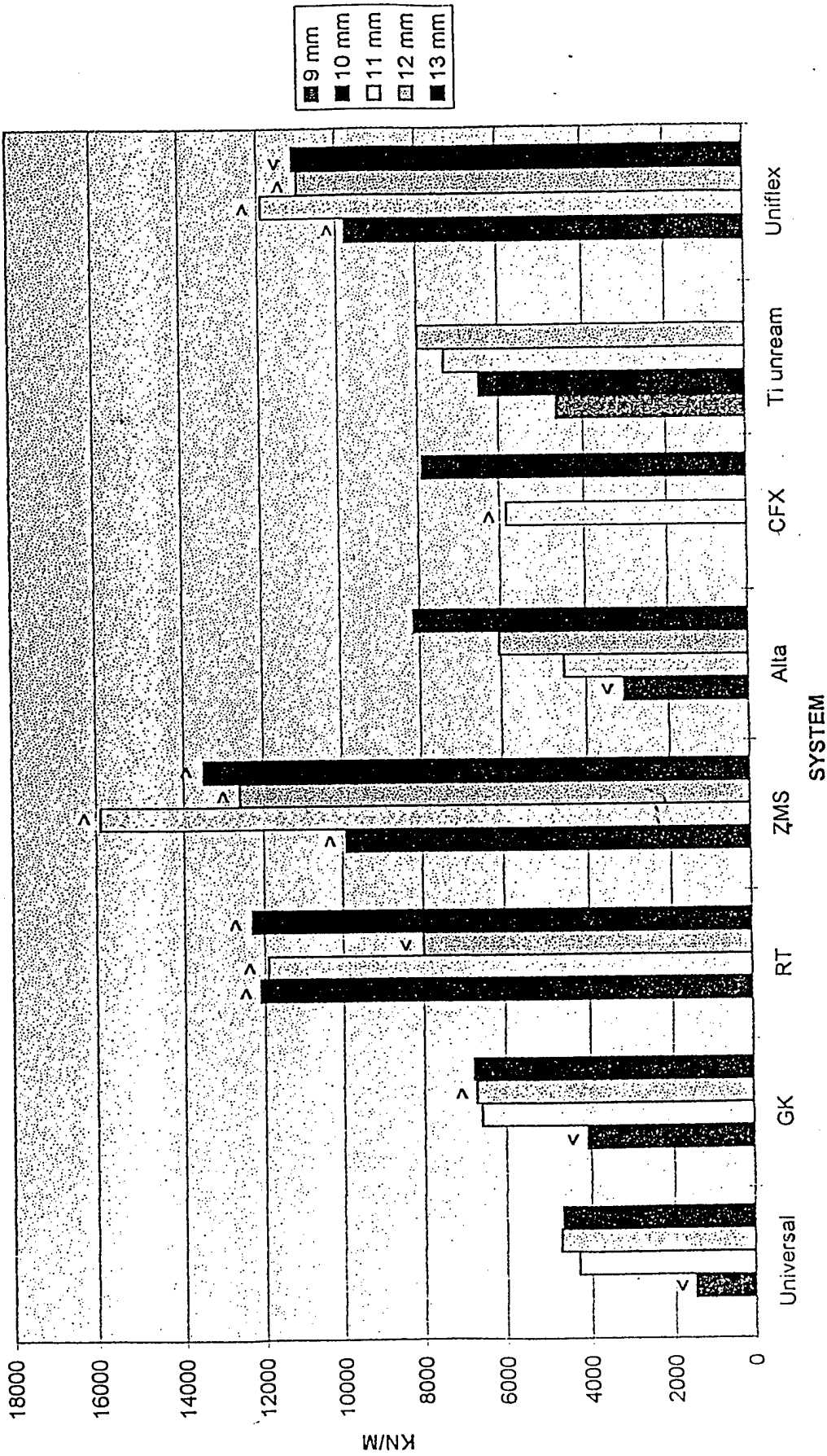
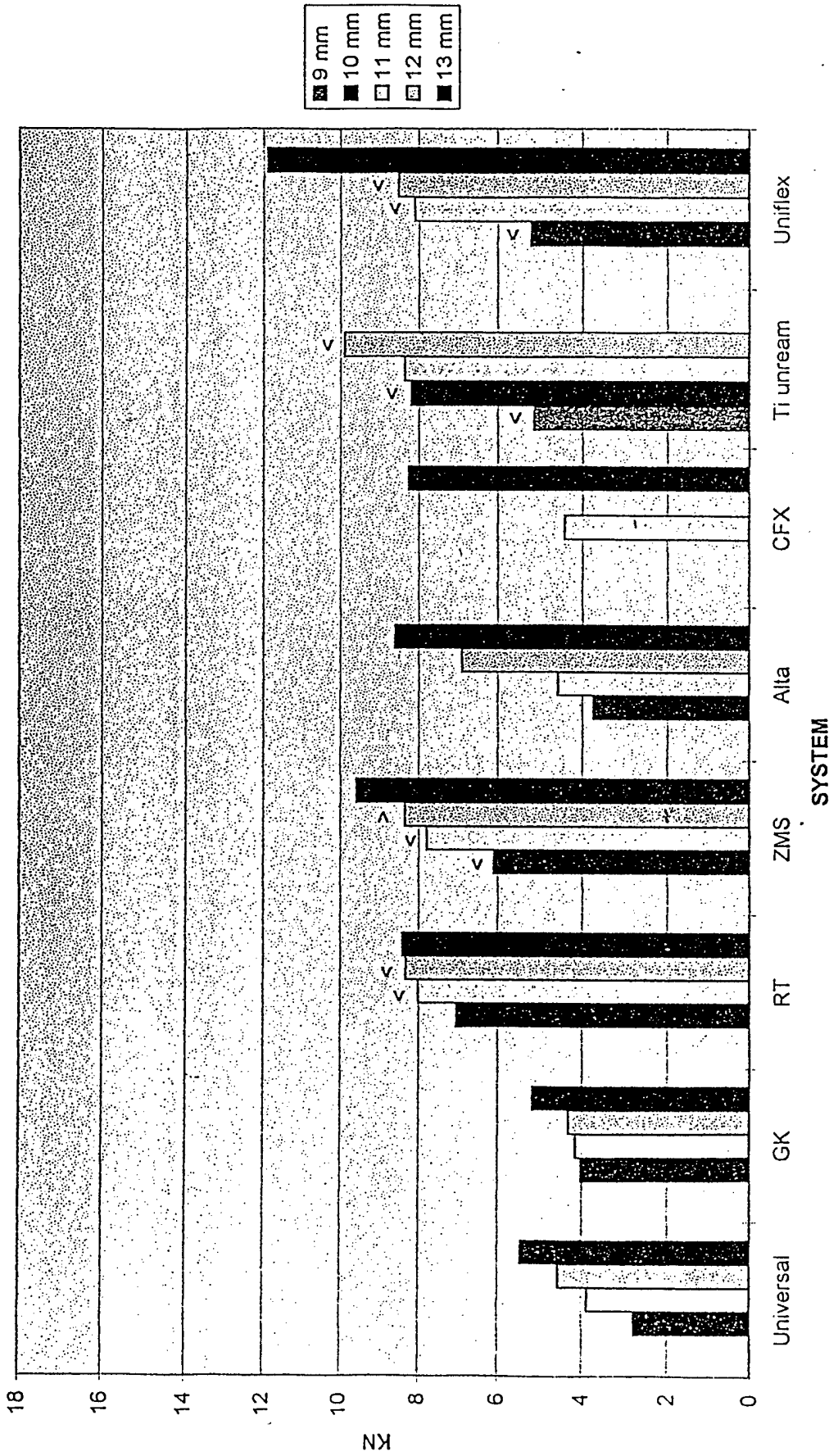

Figure 5: Proximal section rigidity as a function of system and size. Character above a bar indicates that a statistically significant difference exists for this section as compared with the middle section. The character also indicates whether the value is greater than or less than the middle section.

# STRENGTH - DISTAL



**Figure 6:** Distal section strength as a function of system and size. Character above a bar indicates that a statistically significant difference exists for this section as compared with the middle section. The character also indicates whether the value is greater than or less than the middle section.

# RIGIDITY - DISTAL

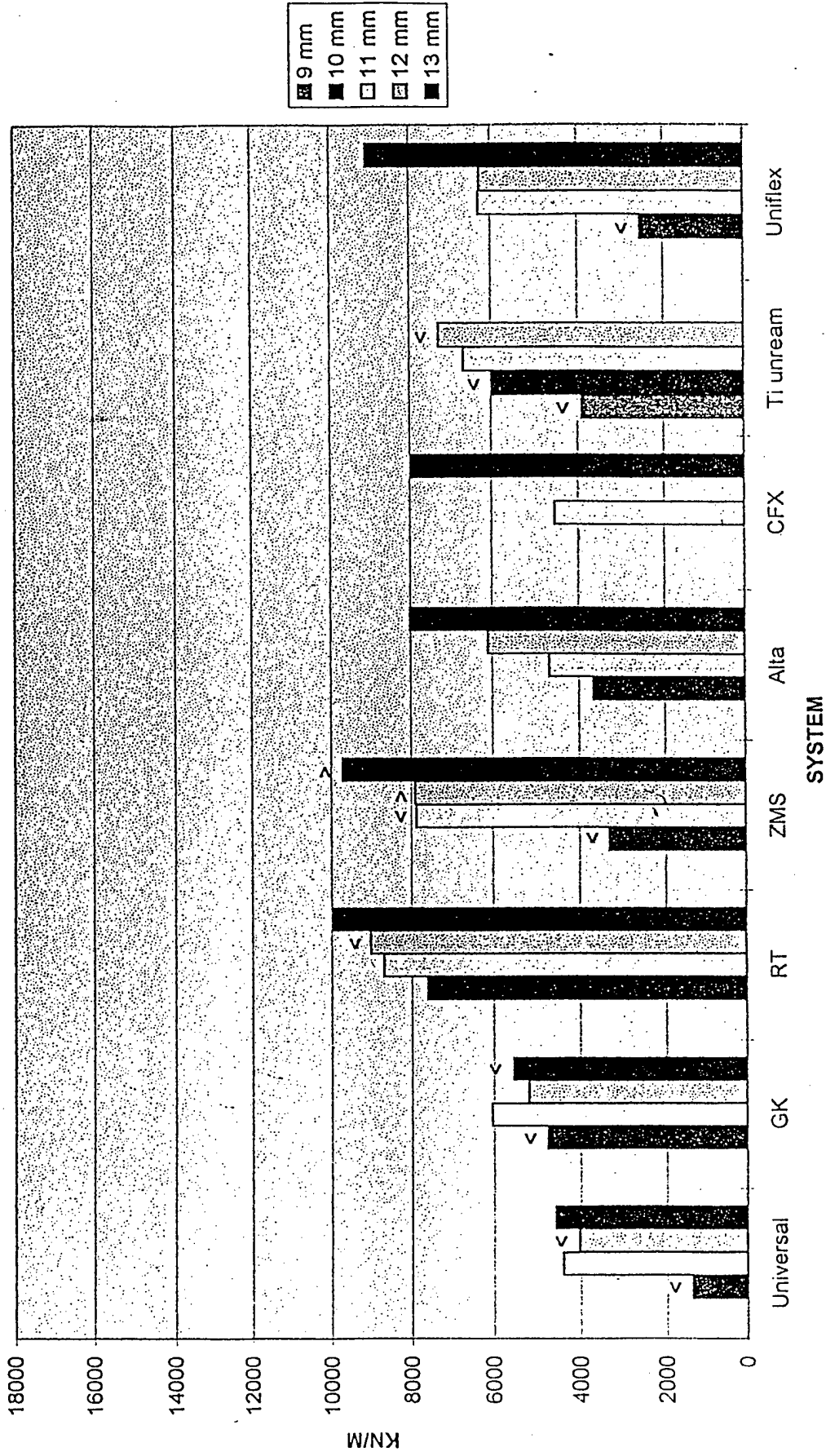

**Figure 7:** Distal section rigidity as a function of system and size. Character above a bar indicates that a statistically significant difference exists for this section as compared with the middle section. The character also indicates whether the value is greater than or less than the middle section.

APPENDIX 1 - DATA FOR STRENGTH AND RIGIDITY BY MANUFACTURER, SYSTEM, AND SIZE  
 NOTE: >, < INDICATES A GREATER OR LESSER STATISTICALLY SIGNIFICANT  
 DIFFERENCE BETWEEN MIDDLE AND PROXIMAL OR DISTAL SECTIONS (P<0.05)

MANUFACTURER	SYSTEM	SIZE mm	SECTION	STRENGTH KN	S.D. KN	P < 0.05	RIGIDITY KN/M	S.D. KN/M	P < 0.05
SYNTHESE	UNIVERSAL	10	M	3.54	0.118		2090	144	
			P	2.88	0.283		1500	179	<
			D	2.78	0.093		1380	246	<
		11	M	4.68	0.18		4220	425	
			P	4.22	0.148		4300	42	
			D	3.88	0.161		4400	405	
		12	M	4.97	0.333		4700	328	
			P	4.1	0.241		4730	160	
			D	4.56	0.404		4030	374	<
	13	M	5.63	0.363		5380	465		
		P	4.54	0.6		4680	548		
		D	5.45	0.428		4570	329		
HOWMEDICA	G-K	10	M	4.59	0.319		5550	101	
			P	4.3	1		4080	567	<
			D	4.02	0.289		4750	349	<
		11	M	5.51	0.255		6500	235	
			P	5.2	0.369		6580	614	
			D	4.15	0.364		6040	260	
		12	M	5.48	0.115		5370	314	
			P	5.16	0.431		6690	120	>
			D	4.32	0.276		5190	148	
	13	M	6.44	0.353		6520	249		
		P	5.84	0.77		6760	704		
		D	5.17	0.246		5540	384	<	

MANUFACTURER	SYSTEM	SIZE mm	SECTION	STRENGTH KN	S.D. KN	P < 0.05	RIGIDITY KN/M	S.D. KN/M	P < 0.05
RICHARDS	RT	10	M	7.38	0.363	>	7650	259	>
			P	12.31	0.884	>	12100	216	>
			D	7.04	0.279	<	7610	131	>
	11	M	9.51	0.369	>	9060	432	>	
		P	12.5	0.386	<	11900	225	>	
		D	8.01	0.313	<	8690	51.3	>	
	12	M	10	0.0264	>	10702	228	<	
		P	13.5	1.36	<	7990	869	<	
		D	8.33	0.364	>	9020	461	<	
13	M	10.1	0.72	>	10600	695	>		
	P	14.2	3.25	<	12300	486	>		
	D	8.41	0.0954	>	9950	235	>		
ZIMMER	ZMS	10	M	8.15	0.232	>	4590	351	>
			P	16.6	0.814	<	9910	356	<
			D	6.1	0.0857	>	3320	72.5	<
	11	M	9.61	0.421	>	9040	207	>	
		P	14.4	2.11	<	15900	1050	>	
		D	7.79	0.435	>	7870	155	<	
	12	M	5.99	0.0838	>	5470	146	>	
		P	10.7	0.471	>	12600	605	>	
		D	8.35	0.665	>	7910	451	>	
13	M	10.4	0.339	>	8560	209	>		
	P	12.5	0.65	>	13500	533	>		
	D	9.6	0.383	>	9710	180	>		

3	MANUFACTURER	SYSTEM	SIZE mm	SECTION STRENGTH KN	S.D. KN	P < 0.05	RIGIDITY KN/M	S.D. KN/M	P < 0.05
3	HOWMEDICA	ALTA	10	M	4.58	0.429	3950	117	
				P	4.23	0.229	3090	544	<
				D	3.74	0.475	3670	50.1	
			11	M	5.27	0.0563	4850	134	
				P	5.23	0.192	4530	169	
				D	4.58	0.534	4670	286	
		12	M	7.84	0.609	6900	194		
			P	6.78	0.61	6040	262		
			D	6.9	0.183	6090	152		
	HOWMEDICA	CFX	11	M	10.3	0.146	8410	166	
				P	8.7	0.514	8150	391	>
				D	8.61	0.88	8010	452	
13			M	5.66	0.154	5000	113		
			P	6.51	0.357	5840	269		
			D	4.42	0.186	4540	85		
	13	M	10.8	0.224	8710	326			
		P	9.91	0.963	7890	789			
		D	8.26	0.274	7960	261			

MANUFACTURER	SYSTEM	SIZE mm	SECTION STRENGTH KN	S.D. KN	P < 0.05	RIGIDITY KN/M	S.D. KN/M	P < 0.05
SYNTHESES	T1 UNREAMED	9	8.33	0.124		4390	104	
			10.7	0.988	>	4640	364	
			5.13	0.524	<	3900	226	<
		10	11.5	0.639		6560	54	
			9.23	0.395	<	6460	99	
			8.2	0.633	<	5970	61.8	<
		11	11.5	0.337		7070	144	
			12.4	0.729		7320	288	
			8.36	0.445		6650	272	
BIOMET		12	14	0.743		8180	340	
			13.5	1.36		7990	869	
			9.91	1	<	7270	399	<
		10	6.87	0.52		3780	287	
			15.9	1.17	>	9780	925	>
			5.21	0.625	<	2540	287	<
		11	9.75	0.5		6460	412	
			16.6	1.44	>	11900	551	>
			8.1	0.636	<	6270	317	<
		12	10.1	0.268		6520	482	
			16.4	0.437	>	11000	266	>
			8.52	0.238	<	6250	289	<
	13	13	1.83		8850	1070		
		14.7	2	>	11100	532	>	
		11.9	0.962		9070	795		



## APPENDIX 2 (CONT) / STRENGTH

11 mm		MID							
	Univer	G-K	Alta	CFX	RT	ZMS	Uniflex	Ti unre	
Universal									
G-K									
Alta									
CFX									
RT	>	>	>	>					
ZMS	>	>	>	>					
Uniflex	>	>	>	>					
Ti unream	>	>	>	>	>	>	>		

11 mm		PROX							
	Univer	G-K	Alta	CFX	Ti unre	RT	ZMS	Uniflex	
Universal									
G-K									
Alta									
CFX	>								
Ti unream	>	>	>	>					
RT	>	>	>	>					
ZMS	>	>	>	>	>	>			
Uniflex	>	>	>	>	>	>	>		

11 mm		DIST							
	Univer	G-K	CFX	Alta	ZMS	RT	Uniflex	Ti unre	
Universal									
G-K									
CFX									
Alta									
ZMS	>	>	>	>					
RT	>	>	>	>					
Uniflex	>	>	>	>					
Ti unream	>	>	>	>					











## APPENDIX 3 (CONT) / RIGIDITY

13 mm	MID						
	Univer	G-K	Alta	ZMS	CFX	Uniflex	RT
Universal							
G-K	>						
Alta	>	>					
ZMS	>	>					
CFX	>	>					
Uniflex	>	>					
RT	>	>	>	>	>	>	

13 mm	PROX						
	Univer	G-K	CFX	Alta	Uniflex	RT	ZMS
Universal							
G-K	>						
CFX	>	>					
Alta	>	>					
Uniflex	>	>	>	>			
RT	>	>	>	>	>		
ZMS	>	>	>	>	>	>	

13 mm	DIST						
	Univer	G-K	CFX	Alta	Uniflex	ZMS	RT
Universal							
G-K							
CFX	>	>					
Alta	>	>					
Uniflex	>	>					
ZMS	>	>	>	>			
RT	>	>	>	>			