

DECISION MAKER'S GUIDE TO ISSUES EFFECTING POST-CLOSURE  
REUTILIZATION OF MUNICIPAL SOLID WASTE LANDFILLS

BY

ROBERT W. GANOWSKI  
LT, CEC, USN

UNCLASSIFIED UNRESTRICTED 4

A REPORT PRESENTED TO THE GRADUATE COMMITTEE  
OF THE DEPARTMENT OF CIVIL ENGINEERING IN  
PARTIAL FULFILLMENT OF THE REQUIREMENTS  
FOR THE DEGREE OF MASTER OF ENGINEERING

UNIVERSITY OF FLORIDA

Summer 1996

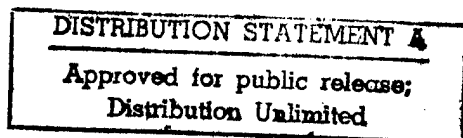

19960826 069

# DISCLAIMER NOTICE

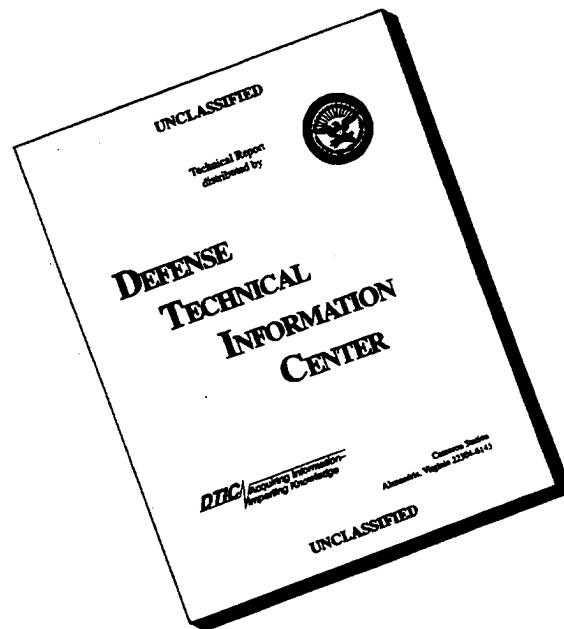

**THIS DOCUMENT IS BEST QUALITY AVAILABLE. THE COPY FURNISHED TO DTIC CONTAINED A SIGNIFICANT NUMBER OF PAGES WHICH DO NOT REPRODUCE LEGIBLY.**

AD NUMBER	DATE 15 Aug 96	DTIC ACCESSION NOTICE
1. REPORT IDENTIFYING INFORMATION		<b>REQUESTER:</b> 1. Put your mailing address on reverse of form. 2. Complete items 1 and 2. 3. Attach form to reports mailed to DTIC. 4. Use unclassified information only. 5. Do not order document for 6 to 8 weeks.  <b>DTIC:</b> 1. Assign AD Number. 2. Return to requester.
A. ORIGINATING AGENCY NAVAL POSTGRADUATE SCHOOL, MONTEREY, CA 93943		
B. REPORT TITLE AND/OR NUMBER A report presented to the graduate committee of the dept of Civil Engr in partial fulfillment		
C. MONITOR REPORT NUMBER University of GANOWSKI, Robert W Thesis Florida Summer 1996		
D. PREPARED UNDER CONTRACT NUMBER N00123-89-G-0549		
2. DISTRIBUTION STATEMENT  APPROVED FOR PUBLIC RELEASE; DISTRIBUTION UNLIMITED		

DTIC Form 50  
DEC 91

PREVIOUS EDITIONS ARE OBSOLETE

DECISION MAKER'S GUIDE TO ISSUES EFFECTING POST-CLOSURE  
REUTILIZATION OF MUNICIPAL SOLID WASTE LANDFILLS

BY

ROBERT W. GANOWSKI  
LT, CEC, USN

A REPORT PRESENTED TO THE GRADUATE COMMITTEE  
OF THE DEPARTMENT OF CIVIL ENGINEERING IN  
PARTIAL FULFILLMENT OF THE REQUIREMENTS  
FOR THE DEGREE OF MASTER OF ENGINEERING

UNIVERSITY OF FLORIDA

Summer 1996

DISTRIBUTION STATEMENT A

Approved for public release;  
Distribution Unlimited

## TABLE OF CONTENTS

ABSTRACT .....	iv
Problem Statement .....	v
Objective .....	v
Literature Search .....	v
CHAPTER 1 - INTRODUCTION .....	1
CHAPTER 2 - EVOLUTION OF LANDFILLS .....	3
Historical Perspective .....	3
Development of Modern Landfills .....	4
Landfills as a Component of the Integrated Solid Waste Management Hierarchy .....	5
CHAPTER 3 - LIFE CYCLE OF A LANDFILL .....	8
Need for a Landfill .....	8
Planning and Siting .....	9
Design .....	11
Construction .....	12
Operation .....	12
Closure .....	13
Post-Closure .....	14
CHAPTER 4 - CLOSURE AND POST-CLOSURE .....	15
Landfill Closure .....	15
Post-Closure .....	18
CHAPTER 5 - SOCIOECONOMIC FACTORS .....	21
Why Consider Landfill Re-use .....	21
Compatibility .....	22
Liability .....	22
Investment .....	23

CHAPTER 6 - LANDFILL GAS GENERATION, MIGRATION AND CONTROL .....	25
Gas Composition and Generation .....	25
Landfill Gas Hazards .....	28
Control Measures .....	30
Prevention of Lateral Migration .....	31
Prevention of Migration into Structures .....	35
Beneficial Recovery of Landfill Gas .....	38
Industry Hills Landfill Gas Recovery Case Study .....	42
Venice Park Landfill Gas Recovery Case Study .....	42
CHAPTER 7 - DIFFERENTIAL SETTLEMENT .....	44
Causes and Mechanics of Settlement .....	44
Analysis and Design Considerations .....	46
Mitigating Effects of Settlement .....	47
Structural Systems .....	47
Utilities .....	53
Site Improvements .....	55
CHAPTER 8 - REVEGETATION .....	56
Landfill Gas .....	56
Landfill Cover Penetration .....	58
Landfill Environment .....	58
Revegetation Steps .....	59
CHAPTER 9 - RECLAMATION AS A PROGRESSIVE OPTION .....	60
Benefits of Reclamation .....	60
Concerns Regarding Reclamation .....	62
Promising Developments .....	62
CHAPTER 10 - CONCLUSION .....	63

APPENDIX A - Closure Plan for Alachua County, FL. Southwest Landfill . . . . .	65
APPENDIX B - Cost Estimate for Final Cover at Alachua County, FL. Southwest Landfill . . . . .	75
APPENDIX C - Landfill Closure Design and Construction Checklist . . . . .	76
APPENDIX D - Miscellaneous End-Use Plans . . . . .	77
REFERENCES . . . . .	83

## ABSTRACT

Municipal solid waste landfills serve as society's primary waste handling mechanism and have promising potential to continue as a community asset well after their capacity has been reached. This guide aims to familiarize the reader with landfills and the issues that can effect their potential after closure.

Landfills have evolved into technologically advanced facilities that are designed, constructed, and operated with strict environmental controls. When a landfill reaches capacity, it must be formally and properly closed, ensuring that the environment and public health will continue to be protected. To establish a baseline, the guide will discuss the landfill's evolution, its life-cycle, and closure/post-closure requirements.

The acreage of a closed landfill site offers wonderful opportunities for beneficial re-use. There are, however, several imperative issues that must be appreciated and considered when evaluating options for a closed, or soon to close, landfill: socioeconomics, landfill gas, settlement, and revegetation. Each of these issues is a potential obstacle to successful re-use. Conversely, if their associated hazards are known and mitigating methods are selectively applied, the issues can breed innovation and opportunity. The focus of this guide is to address these issues and present techniques that can lead to a fruitful re-use effort.

Although post-closure re-use is a logical goal, this guide will also introduce developments and research in landfill mining and accelerated waste decomposition that offer promise for extending the life of landfills. Extending the life of a landfill complements a proactive re-use strategy. Accounting for the issues discussed in this guide and exercising foresight will facilitate the smooth transition of a closed landfill into a symbol of community pride.

## **Problem Statement**

There is a lack of comprehensive literature for decision makers regarding the issues that can influence beneficial re-use of closed municipal solid waste landfills.

## **Objective**

The objective of this document is to provide a comprehensive guide that familiarizes the reader with the issues influencing post-closure re-use of municipal solid waste landfills. The guide will present the issues, discuss associated risks, and outline steps that can be taken to mitigate the risks.

## **Literature Search**

In developing this guide, the author pursued the following reference categories:

1. General books relating to solid waste management and landfill design.
2. Scholarly reports and conference papers related to landfill gas, differential settlement, and revegetation.
3. Magazine and professional journal articles relating to closure and post-closure, re-use case studies, and landfill mining developments.
4. Applicable Federal and State regulations
5. Documents relating to a local landfill approaching closure.
6. Summaries and reports of related conferences and workshops.
7. Documentation of successful landfill re-use projects.

The categories listed above are not exhaustive. The references are listed in the guide and are excellent sources for further study of the issues presented.

## CHAPTER ONE INTRODUCTION

Municipal Solid Waste Landfills have evolved into a community asset and must continue that function after closure. Waste disposal practices have progressed from crude dumping to environmentally proactive landfilling. The progression has involved innovative technology and sweeping legislation with the objective of reducing the risks to public health and the environment. Today the landfill is a carefully engineered and constructed facility with regulations guiding every aspect of its life-cycle, from conception to post-closure. Appreciating the history and life-cycle of a modern landfill is essential to making sound decisions regarding its continued role as a community asset.

The closure and post-closure requirements for a completed landfill are largely governed by regulation, however, they should be tailored to the planned end-use of the facility. Current regulations mandating closure and post-closure plans at the beginning of the landfill's life-cycle facilitate successful re-use. Unfortunately, many older facilities have operated without such plans guiding their operation. Communities across our nation and abroad have proactively converted landfills of various age and construction to beneficial facilities such as parks, playing fields, golf courses, ski areas and wildlife areas. The end-uses vary greatly in function and complexity. Regardless of the planned end-use, socioeconomic factors, the effects of landfill gas and differential settlement, and revegetation challenges must be considered and accounted for.

Landfill re-use can have aesthetic, functional and economic benefits. Community leaders must, however, emphasize practical and affordable development on sites that are believed to be free of hazardous waste deposits.

Although a potential hazard, landfill gas can be effectively controlled and even recovered as an energy or fuel source. There are proven methods to prevent the lateral migration of gas or its migration into on-site structures. Today's design, construction, and monitoring requirements significantly minimize any risks.

Differential settlement can potentially cause significant structural and site damage. Settlement, similar to landfill gas generation, is inevitable. The detrimental effects can be mitigated through time, site improvements and special construction techniques, allowing various types of development.

The revegetation of a site will be required in all cases. Planting on closed landfill is effected by landfill gas, root restrictions and a harsh environment. Successful revegetation will require careful plant selection, soil amendment and close monitoring.

Although beneficial re-use of a closed landfill is a respected goal, delaying closure has obvious benefits. Landfill reclamation through mining is an inviting option to consider as a landfill approaches closure. Recent reclamation projects and research related to accelerated decomposition of landfills promise progressive changes in landfill operation.

Advance planning, foresight, and an open mind can classify a municipal solid waste landfill as an indefinite community asset. Neglect or ignorance of post-closure end-use issues can lead to project failure, financial loss and worst of all, death or injury of citizens.

## CHAPTER TWO EVOLUTION OF LANDFILLS

### Historical Perspective

Modern Municipal Solid Waste (MSW) disposal practices have evolved through a series of pivotal and progressive changes. Solid wastes have been historically discarded whenever and wherever convenient, often without regard for the impact on public health or the environment. Fortunately, in the pre-industrial era, wastes generated did not have the toxicity that developed with the onset of technological advances. These wastes, composed primarily of food and animal remains, were commonly thrown into streets and waterways, leading to the spread of disease carrying vectors. This practice was most evident in the cities of medieval Europe. As cities grew and became more densely populated, some changes eventually occurred. In the 19th century, people realized that wastes had to be collected and disposed of in a sanitary manner to control carriers of disease (1, p.5). Consequently, it became common practice to dispose of waste 'out of sight and out of mind' by simply burning or covering it.

With the onset of manufacturing processes during the Industrial Revolution and beyond, the wastes that needed to be disposed of became increasingly toxic to humans, wildlife and the environment. Hazardous by-products were generated without much change in the waste disposal practices. Population skyrocketed both abroad and in the United States; cities sprouted and flourished; industry and manufacturing rates exploded. The generation of wastes by residential, commercial and industrial sources increased accordingly. The complex waste streams were primarily deposited in uncontrolled open dumps or in the coastal waters.

## Development of Modern Landfills

Unplanned and unengineered disposal sites flourished well into the 20th century (1, p.361). As the health and environmental risks of open dumps became apparent to field experts, government agencies, and the public, legislation and technology was developed in an attempt to dispose of society's wastes in a manner that minimized risks. These initiatives led to the design, construction and operation of 'sanitary landfills'. A 'sanitary landfill' can be defined as an engineered method of land-based solid waste disposal that protects human health and the environment, by spreading waste in thin, compacted layers, and applying suitable cover material at the end of each working day (1, p.911). This type of facility was introduced in the 1940's (1, p.8). Even though progress was evident, problems and inconsistencies with landfilling practices continued. By the 1970's, 94% of all landfill sites were classified as open dumps (2, p. 1).

The Resource Conservation and Recovery Act (RCRA) of 1976 was the first legislation that significantly changed disposal practices nationwide. RCRA called for the survey and closure of open dumps (1, p.28). Under the authority of RCRA, in 1979, the U.S. Environmental Protection Agency (EPA) issued the Criteria of Classification of Solid Waste Disposal Facilities and Practices, Volume 40 of the Code of Federal Regulations Part 257 [40 CFR 257]. The Criteria established minimum environmental performance standards for sanitary landfills and required the states to develop plans for prohibiting new open dumps and upgrading or closing existing ones (3, p.10).

Since the imposition of RCRA, the design, construction and operation of sanitary landfills continued to be studied by professionals and scrutinized by the public. Public laws and

amendments to RCRA were accordingly issued with continually stricter mandates and guidelines. These legislative actions focused on protection of the environment and the public, thus influencing further advancements in landfill technology . Today, minimal standards for municipal solid waste landfills are promulgated in 40 CFR 258, Criteria for Municipal Solid Waste (MSW) Landfills. This regulation provides specific guidance for siting, operation and design, groundwater monitoring, closure and post closure (4). The states can, however, and in many cases do, impose stricter regulations. A modern MSW landfill is comprised of numerous advanced components such as composite liners and leachate collection systems, providing layers of engineered protection. Despite these assurances, concerns for the environment, property values, traffic congestion and aesthetics continue to persist (5, p.11).

#### **Landfills as a Component of the Integrated Solid Waste Management Hierarchy**

In the 1980's, government agencies, solid waste professionals and community leaders began advocating and actively implementing an integrated approach to solid waste management. This initiative is exemplified by such localized legislative action as the Florida Solid Waste Management Act of 1988. This act, similar to many others around the nation, established policy to promote waste reduction, recycling and resource recovery as an alternative to landfilling of wastes (6, p.1). Landfilling of waste, however continues to be a very important component of this strategy. In Florida, for example, approximately 38 % of MSW generated was landfilled in 1995 (7). Figure 2-1 shows the trend for MSW management in the State of Florida. Although the percentage of MSW being landfilled has decreased significantly since 1989, the annual rate of decrease has subdued.

## FLORIDA MSW MANAGEMENT, WEIGHT %

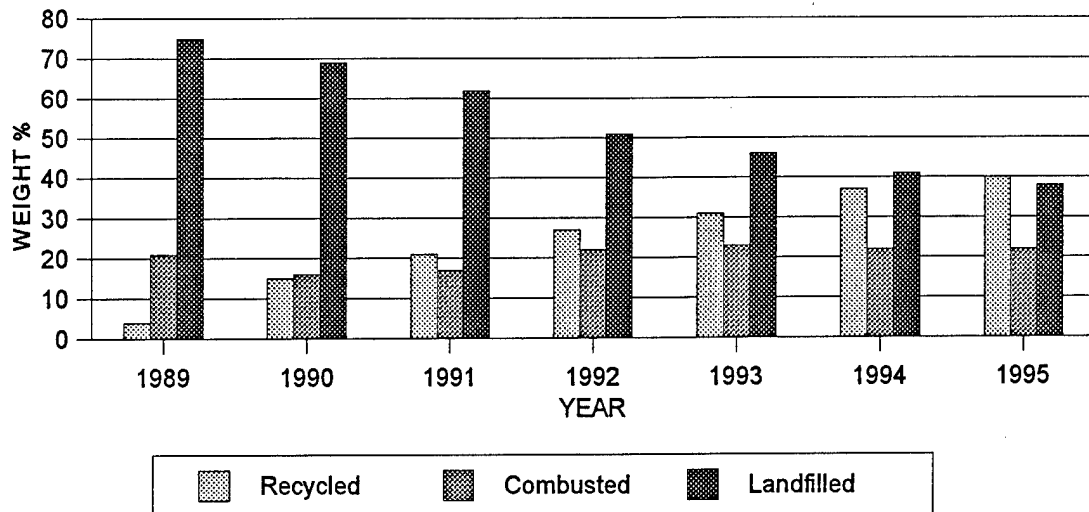

**Figure 2-1.** Florida MSW Management Trends [1989-1995] (Source: Florida Department of Environmental Protection, Waste Management, Solid Waste Section)

The currently accepted hierarchy of waste management, as initiated by the U.S. Environmental Protection Agency (EPA), is source reduction, recycling, waste transformation and finally landfilling for residue materials and products that cannot be effectively or economically recycled or transformed (1, p.15). Source reduction relates to action that reduces the quantity of wastes generated. Recycling results in the reuse, reprocessing and remanufacture of waste materials. Waste transformation alters the properties of the waste material, ultimately reducing the amount of the original waste that must be landfilled. Landfilling is the least preferred, yet inevitable, component of the hierarchy (1, p.15-16).

Even though recycling initiatives and waste minimization programs reduce the amount of waste, they cannot solve the problem alone (8, p.22). Innovative research, such as that conducted by the University of Florida, in the area of waste decomposition and waste

treatment provides great hope in stunting the explosive expansion of landfill acreage (9). Increasing population will inevitably work against technology and positive management actions. The cross-section, operation, and technology of landfills will definitely change in the future. Issues such as regionalization of waste facilities, landfill siting, and protection of the environment will continue to make headlines. Landfills will, however, always be with us in some form and must become a community and public asset instead of a liability, perceived or real (1, p.21).

## CHAPTER 3 LIFE CYCLE OF A LANDFILL

Preparation for evaluating MSW landfill post-closure options begins with an understanding and appreciation of the landfilling cycle, from conception through long-term care. The decisions, considerations and technology that shaped a particular landfill are extremely important elements when planning practical uses. The landfilling process is complicated and advanced and will simply be summarized in this guide.

### **Need for a Landfill**

The complex structures known as landfills by some, or 'dumps' by others, arise from a municipality's need to safely dispose of waste that 'cannot' be handled through other means. Today, landfills are primarily conceptualized when an existing landfill is on the verge of being filled to capacity or has been ordered to close because of non-compliance with regulations. This reality of need often becomes a premier issue in community planning and politics. Municipalities may consider many options and strategy combinations in hope of delaying or eliminating the need for a landfill. Recycling plans are reviewed; source reduction is revisited; composting and incineration is pondered. Frequently, transporting MSW to a distant regional landfill is studied. When all is 'said and done', many municipalities are still left with no choice but to begin planning for a landfill to serve a growing population. Even with the most effective MSW management plans and diversion programs, a landfill of some form will most likely be needed.

## **Planning and Siting**

Once the reality of a landfill takes root, the most agonizing phase of the process begins; the landfill site must be chosen. The planners and engineers first consider the projected waste production and the percentage of the waste that will ultimately be landfilled. This involves careful analysis of expected population changes, changes in the composition of the waste, and the projected effect of current or planned diversion programs. An aggressive yard waste or paper recycling program, for example, will reduce the disposal volumes. Such analysis leads to an estimate of landfill size for a desired life expectancy. Adjoining support structures and buffer zones are incorporated into the final required acreage.

With a space estimate known, complex siting criteria must be evaluated. The factors that typically impact site selection can be categorized as economic, political, and environmental, and are summarized in Table 3-1 (3, p.19). The factors will have varied levels of significance

**Table 3-1. Landfill Siting Factors**

<b>Economic</b>	<b>Political</b>	<b>Environmental</b>
Land availability and cost	Archaeological and historical	Wetlands and Flood Plains
Utility connections	Land Use Compatibility/Zoning	Threatened or Endangered Species
Site Access	Noise and Dust	Slope
Site Flexibility	Aesthetics	Air Quality and Odors
Capacity potential	Traffic	Soils and Geology
Development, Operation, and maintenance cost	End-Use potential	Topography
Compatibility with existing solid waste management systems	Property values	Monitoring requirements
Haul Distance		Surface and Groundwater Hydrology
		Climatology

**Source:** ( 1, 3 and 10)

to communities. Some of the factors, however, are regulated through legislation. Minimum guidelines for location restrictions are promulgated in 40 CFR 258; the restrictions apply to areas in the vicinity of airports, floodplains, wetlands, fault areas, seismic impact areas and unstable areas (4). Individual states will often impose additional restrictions, depending on the perceived threat to the local environment. Florida, for example, has published specific prohibitions in Florida Administrative Code [FAC], Chapter 62-701, Solid Waste Management Facilities (11). A review of regulatory restrictions, soil and hydrology data, and land use guidelines will normally eliminate many areas from consideration. More detailed studies are then conducted to determine the best site. Final selection of a site is based on the results of a detailed site survey, engineering design and cost studies, and an environmental impact statement (1, p.377).

Violent opposition to the landfill is inevitable. This opposition, whether founded or unfounded, has been labeled as the "Not In My Backyard" (NIMBY) syndrome. This attitude has a long history and continues to prevail as citizens have strong concerns over environmental pollution, health risk, decreasing property values and aesthetics. This opposition is normally met with portrayals of the environmental protection measures planned, statistics showing minimal risks, and post closure plans of parks and golf courses. This public process is a time consuming affair. The objective is to select a site that promises the greatest protection to the environment in the event the technology fails (3, p. 19).

## Design

Once a decision is reached regarding the best site, the detailed design and permitting process begins. The design should incorporate best available technology to adequately protect the environment and public health. Minimum design criteria are given in 40 CFR 258.40 (4) and are normally expanded in state regulations. Florida promulgates specific standards in FAC, Rule 62-701.400 (11).

The local geological and hydrological characteristics form the baseline for the design. Borings, soil and groundwater samples must be, therefore, obtained to ascertain the stability and vulnerability of the site. For prevention and detection of leachate or gas migration, intricate liners and collection and monitoring networks must be designed and costed. The handling of the leachate and landfill gas is also an important consideration. Will the leachate be collected and treated or will it be recirculated through the landfill to accelerate decomposition (9). Will the gases be flared or will they be collected, processed and used for energy generation? Specific tolerances and performance criteria need to be determined for critical system components and then balanced with cost effectiveness. Although environmental controls are given priority, perimeter support facilities that ensure safe and efficient operation and administration must also be incorporated into the site.

Closure and post-closure plans are integral elements of the design and permitting stage. Consideration of end uses at this stage is imperative. Unfortunately, in many cases, post-closure application of the site is not adequately evaluated or is brought up too late. With adequate foresight, the landfill components and operational plan can be designed with a particular use in mind. If this is not done, post closure uses may be limited, risky, or involve

large capital expenditures. The design process will effect the landfill's operation and behavior for many years to come.

### **Construction**

The construction of a modern landfill is a costly and complex endeavor. It requires flawless attention to the specifications delineated by the designers, and meticulous quality control and assurance from ground breaking to completion. Elements of the construction process include land clearing, excavation, installation of the liner, installation of leachate, gas and storm water control systems, and installation of the groundwater monitoring system (10, p.446). The testing requirements, progress checkpoints and costs must be closely monitored throughout. Flaws in any component can lead to a devastating release to the environment when the landfill opens for operation. Since the landfill owner is ultimately responsible for any faulty construction, the quality control personnel and procedures must be carefully planned (12, p.245). When construction is complete, all related documents such as specifications, quality control reports and as-built drawings need to be retained. Such information will become invaluable for troubleshooting and end use considerations.

### **Operation**

When the landfill structure is in place, the first load of MSW is not far behind. Controls must be established to monitor quality and quantities of waste placed in the landfill. Monitoring for the influx of hazardous wastes is especially critical. The placement of the waste in the fill site is planned to maximize efficiency. The enforcement of proper compaction and placement of daily cover will lengthen the life of the landfill while minimizing odor, vectors and blowing of the waste. Ensuring the availability of the daily cover material

requires long-term planning due to the substantial quantities involved (10, p.441). Other site operating issues include control of noise, odor, litter, dust, birds, rodents and insects (10, p.450-453). Record keeping, security and user convenience are also important components of the operations plan (10, p.453-455).

Environmental monitoring is mandatory as promulgated by state legislation. Normally monitoring requirements include groundwater, liner performance, landfill gas, leachate and surface water (10, p.458-459). Any detection of regulated contaminants above minimum standards will have to be reported and can lead to expensive testing and remediation.

A maintenance plan for the collection and monitoring systems needs to be actively implemented to ensure safe and efficient operation. The costs of operation and maintenance should be closely monitored for efficiency and future planning purposes. Since the owner or operator of a landfill must demonstrate the financial capability to perform closure and post closure activities, a funded trust should be established during the active life of the site (10, p.445). Astute operation and control of an active landfill will undoubtedly minimize negative public perception and environmental risk.

### Closure

Once the landfill reaches capacity, it must be properly and formally closed. As with the previous phases of the life-cycle, there are specific regulations that dictate closure requirements. These regulations strive to ensure continued protection of the environment and public from potential releases. Volume 40 CFR 258 calls for the installation of a layered final cover system that is designed to minimize infiltration and erosion (4). The regulation further specifies that closure activities must begin no later than 30 days after the date on which the

landfill unit receives the known final receipt of wastes; closure activities must be complete within 180 days following beginning of closure (4). All activities and controls are to be in accordance with a required closure plan that was initiated before the landfill opened.

### Post-Closure

Once closure is complete, the facilities at a closed landfill must be maintained over the period of time that a landfill is producing products of decomposition (1, p.790). Prescribed maintenance periods, governed by regulation, are normally 20-30 years (1, p.791). The post closure maintenance period is designed to minimize threat to the environment and ensure a smooth integration of the site into the surrounding community.

The costs of closure and post-closure requirements can be extremely high, particularly if a release to the environment is detected. Municipalities across the nation are, nevertheless coming up with innovative ways to return landfill sites to the community. The elements of closure and post-closure are discussed in Chapter 4.

**CHAPTER 4  
CLOSURE AND POST-CLOSURE**

**Landfill Closure**

Proper closure of an active landfill is an integral step to transforming a disposal site into a continued community asset. "Closing a landfill can be much more difficult than starting a new one. The owner desires effectiveness and economy, the engineer is often provided sketchy background information, and the contractor faces almost certain changed conditions and disputes" (13, p.107). The purpose of a formal closure process is to ensure that the completed landfill continues to function effectively as an environmental control unit well into the future (1, p.769).

The closure process actually begins during the design phase with the development of a closure plan. Standard elements of a closure plan are presented in Table 4-1.

**Table 4-1. Standard Closure Plan Elements**

<b>Element</b>	<b>Typical Activity</b>
Post Closure End-Use	Designate and Adopt
Final Cover Design	Select the barrier system, final surface slopes and vegetation
Surface Water and Drainage Control	Calculate runoff quantities and select perimeter channel locations to collect stormwater
Control of Landfill Gases	Select locations and frequency of gas monitoring and set operations schedule for gas collection system
Control and Treatment of Leachate	Set the operation schedule for leachate removal and treatment
Environmental Monitoring Systems	Designate sampling locations, frequency of monitoring and constituents to be monitored

**Source:** ( 1, p. 771, Table 16-1)

Federal and state regulations will, however, delineate specific requirements for closure activities and elements. 40 CFR 258.60 governs closure criteria. This regulation mandates the installation of a final cover system that is designed to minimize infiltration and erosion (4).

A cross section of such a cover system is shown below in Figure 4-1.

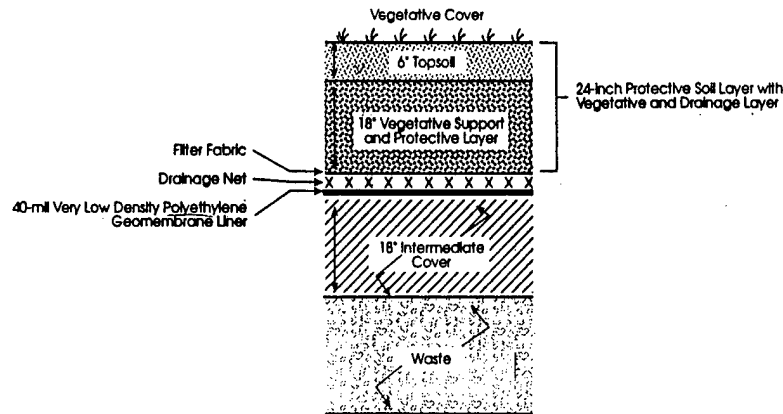

**Figure 4-1.** Typical landfill final cover system (Source: 14, p. 2-29, Fig. 2-10).

The criteria also require the preparation of a written closure plan that describes the steps necessary to close the landfill at any point during its active life. The federal regulation only touches on the primary issues and delegates the responsibility of implementation to the state agencies. The states, in turn, publish more detailed requirements. In Florida, closure is governed by FAC Rule 62-701.600 (11). Florida requires an extensive closure plan in order to obtain a closure permit. Essential components of this closure plan are summarized below.

1. Closure Report consisting of general site information, geotechnical investigation report, water quality monitoring plan, land-use information, gas migration analysis, and an assessment of the effectiveness of landfill design and operation.
2. Closure Design Plan consisting of:
  - a. Plan sheet showing phases of site closing.
  - b. Drawings showing existing topography and proposed final grades.

- c. Provisions to close MSW disposal units upon reaching approved design dimensions.
  - d. Final elevations before settlement.
  - e. Final side slope design.
  - f. Final cover design and installation plans.
  - g. Proposed method of stormwater control.
  - h. Proposed method of access control
3. Closure Operation Plan consisting of:
    - a. Specific actions which will be taken to close the landfill.
    - b. Schedule for completion of the closing and long-term care.
    - c. Proposed method of demonstrating financial responsibility for the long-term care and monitoring and maintenance.
    - d. Plans for development and implementation of a water quality monitoring plan.
    - e. Plans for development and implementation of a gas monitoring program.
    - f. Additional equipment and personnel requirements.
  4. Closure Procedures including inspection, survey, certification and notification.
  5. Long-Term/Post-Closure Care Plan.
  6. Demonstration of Financial Assurance.

Appendix [A] is a closure plan developed by CH2M Hill, Inc., for the Alachua County, FL., Southwest Landfill (15).

The demonstration of financial assurance is a relatively new addition to landfill legislation. Since the costs of landfill closure can cripple a community's finances, planning to meet this requirement must begin early in the landfill life cycle. Unit construction costs will vary with the improvements that must be made to the site, however, \$80,000 to \$100,000 per acre is a reasonable estimate (16,17). Appendix [B] is a 1991 estimate for a cover system at the Alachua County, FL. Southwest Landfill. Methods for establishing and maintaining

financial assurance include bonds, sinking funds, enterprise funds, and pledged revenues or assets of the site owner (1, p.797).

Given this long term investment, advance planning, complete and accurate data, and close coordination between owner, regulator and post-closure operator is critical to success (13). Appendix [C] is a landfill closure design and construction checklist developed by Beaudoin, Stockman and Fletcher (13, p. 111). The checklist was formulated through experience gained on several closure projects.

Additional challenges are faced when integrating regulatory requirements with the unique design elements of post-closure end-use. Although innovation and technology can go a long way in meeting this challenge, a lack of planning is a sure route to failure. Fortunately, the closure regulations tend to compel municipalities to exercise foresight.

#### **Post-Closure**

Once a landfill is formally and legally closed, long-term care and monitoring begins. The FAC Rule 62-701.620 states the following: "The owner or operator of any landfill which receives waste after January 6, 1993, shall continue to monitor and maintain the integrity and effectiveness of the final cover as well as other appurtenances of the facility in accordance with an approved closure plan for 30 years from the date of closing" (11). Under certain circumstances, where the risks to health and environment are essentially non-existent, a reduced care period may be approved. Responsibilities include assuring that the leachate and gas control systems are functioning properly, and that there is no evidence of contamination migrating away from the landfill site. If migration is detected, immediate corrective action will have to be initiated, undoubtedly delaying post-closure plans.

The primary issues that must be addressed in a landfill post-closure plan include (1, p.791):

1. Component inspection procedures and frequency
2. Infrastructure maintenance
  - a. Grading and Landscaping
  - b. Stormwater control systems
  - c. Landfill gas management systems
  - d. Leachate collection networks and treatment facilities
3. Environmental monitoring systems
4. End-use site plans
5. Continuance of financial assurance

Closed landfill inspection items, frequency of inspection and potential problems to be observed are shown in Table 4-2.

**Table 4-2. Post-Closure Inspection**

<b>Inspection Item</b>	<b>Frequency of Inspection</b>	<b>Potential Problems</b>
Final Cover	Annually and after significant precipitation	Erosion/Landslides
Vegetative Cover	Four times per year	Dead Plants
Final Grades	Twice per year	Ponding
Surface Drainage	Four times per year and after significant precipitation	Debris in drains; broken drain pipes
Gas Monitoring	Continuous as required by Post-Closure Plan	Odors; compressor and flare equipment inoperable; high gas readings in monitoring probes; broken gas well pipes
Groundwater Monitoring	As required by equipment and Post-Closure Plan	Damaged wells; inoperable sampling
Leachate Management	As required by Post-Closure Plan	Inoperable pumps; blocked pipes

**Source:** (1, p. 792, Table 16-8)

The post-closure phase of the landfill cycle is very costly and may transcend the tenure of solid waste managers, public works directors and local politicians. Alachua County, FL, expects long-term care costs to be 170% of the landfill final cover system cost (5, p.43).

A municipality has essentially two choices for the closed site. The status-quo choice is to revegetate and monitor the site. The proactive choice is to transform the site into a beneficial community asset for the indefinite future. Although often a challenging venture, communities across the nation have accomplished 'miracles' with closed landfills. Landfills have been successfully reclaimed for many purposes including municipal parks, sports facilities, golf courses, wildlife habitats, a public works complex (18), an environmental community center (19) and an airport extension (20). Whether a beneficial end-use is planned or not, long-term care will have to continue. In order to successfully transform a closed landfill into a community asset, there are imperative issues that must be carefully evaluated and accounted for. These issues are discussed in the forthcoming chapters.

## CHAPTER 5 SOCIOECONOMIC FACTORS

### Why Consider Landfill Re-use

The logical goal upon landfill closure is to maximize the beneficial return to a community. There have been, and will continue to be, innovative conversion and reclamation projects, as open land available for public use dwindles under development pressures. The closed landfill offers precious acreage that can be utilized as a public asset. Since the landfill site is usually owned by the municipality, a significant land acquisition cost is avoided. A San Francisco based organization, Trust for Public Land, recommends that cities explore the possibility of converting former landfills in order to promote cost and space efficiency (21, p.28). Although each project will face unique challenges, a well planned endeavor can turn a long-standing 'eyesore' into an attractive and functional facility.

Although the prospect of economical acreage is the primary attraction of developing closed landfill sites, there are other advantages as well. "Landfill reclamation projects can offset some of the costs associated with the closing of an old landfill and even help turn a profit. The town of Marlborough, MA. earned \$400,000 when it signed a 10-year lease that will turn its 'dump' into a driving range. The facility will be fully constructed and operated by a private company" (22, p.10). In urban areas, closed landfill development can be combined with infrastructure related excavation projects (22, p.10). In Elmhurst, IL., the use of excess material from a flood control project to mitigate settlement on a landfill conversion saved nearly \$2 million in transportation and disposal costs (23, p.30). Such initiatives can undoubtedly lower the construction costs of both projects while benefiting the general public.

The development of closed landfill sites can stimulate economic development and property values. Such a prospect can be the factor that suppresses opposition for a much needed landfill. In Southwest Charlotte, N.C., a MSW landfill was transformed into the York Road Renaissance Community Park. The park houses a full service 18-hole golf course, five lighted softball fields and four lighted soccer fields. The Charlotte Park Superintendent claims that the new park is fostering economic growth in a once stagnant area, attracting businesses and boosting land values (24, p.52). The benefits, both tangible and intangible, of landfill reutilization undoubtedly justify consideration of options.

### Compatibility

The foremost challenge is to decide what form of end-use is best fitted for a community or region. Closed landfills can be found in urban, suburban and rural settings. What will thrive in an urban environment may prove to be a failure in a rural area. As with conventional developments, there is an appropriate place for everything.... a place that makes sense financially and logistically. For example, a golf course is probably not the best choice for a site that is inconvenient for the majority of the potential customers. Growth projections and an honest evaluation of citizen demand are essential considerations. Citizen involvement and input must be encouraged throughout the planning process, since they will be the mainstay of any development. A reuse option that complements the surrounding area and is sustainable will hold the greatest potential for success.

### Liability

Before a closed landfill is considered for re-use, the owner must be confident that the site is free of hazardous wastes that may pose serious health, environmental and financial risks.

This confidence is difficult to garner, especially on older sites with questionable contents. The problem of hazardous wastes is much more significant with landfills opened and operated before RCRA (24, p.53). To establish liability for hazardous waste releases and the clean-up of contaminated sites by responsible persons, the Comprehensive Environmental Response, Compensation and Liability Act [CERCLA] was passed in 1980 (25, p.2-16). This legislation places a direct legal and financial risk on an owner of a site where illegal dumping of hazardous wastes may have occurred. Fortunately, landfills constructed since the implementation of RCRA have been planned and operated in a more responsible manner. Improved recordkeeping should provide a prospective developer information needed to plan for conversion of the site (26, p.258). Regardless of apparent site history or public concern, a thorough subsurface investigation should be executed in order to better ascertain the risks and form a baseline for required corrective measures.

### **Investment**

Unfortunately, the investment required for development of a closed landfill site may be a controlling factor. The closure and post-closure baseline costs are alone ominous. Any further development by a municipality is going to require additional funding. The municipality must consider the capital cost and the maintenance and operation cost of the end-use facility. Surely, there are ventures that will generate proceeds, however, the break-even point is most likely going to be well into the future. An economic analysis is strongly recommended to compare post-closure options. Although the intangible benefits such as aesthetics and public enjoyment are difficult to cost, they do impart much value to a project. There are innovative financing options such as grants and public/private partnerships than can significantly reduce

the burden to the taxpayer. Research into these options may subsidize projects that a community could never afford by itself.

Careful consideration of community impacts and needs, sustainability, and economics will bring a landfill re-use project one step closer to a success story. Hasty decisions can lead to disappointment and citizen mistrust.

## CHAPTER 6 LANDFILL GAS GENERATION, MIGRATION AND CONTROL

### Gas Composition and Generation

The presence of landfill gas and its associated hazards can be a significant deterrent to post-closure development. A grasp of landfill gas make-up and its generation process is essential to understanding the risks and evaluating mitigating techniques.

Landfill gas is a primary output of a landfill and is produced from the microbiological decomposition of organic wastes. The generation of these gases is a complex, yet sequential process. This process can be divided into the following phases (1, pp.385-387; 10, pp.72-73; 27, pp.15-16; ):

1. *Aerobic*: The oxygen that makes up air voids in the deposited wastes and cover material enhances aerobic bacterial decomposition. As the oxygen is consumed by the microorganisms, carbon dioxide is being produced and tends to replace the oxygen. This aerobic process takes only a few days.
2. *Anaerobic, non-methanogenic*: As oxygen is depleted, the landfill becomes anaerobic. Initially the wastes are broken down into soluble components such as glucose, amino acids and fatty acids. These products are then used by the microbes to produce simpler organic acids, water, carbon dioxide, ammonia and hydrogen. Carbon dioxide is produced at an accelerated rate in this phase.
3. *Anaerobic, methanogenic, unsteady*: Carbon dioxide and hydrogen production rates decline. Methane production begins through conversion of acetic acid and hydrogen gas. Significant methane production has been observed as early as three months after closure of a landfill cell.

4. *Anaerobic, methanogenic, steady*: This phase is characterized by the steady generation of relatively constant composition gas. Studies show that the composition will vary from 40-70% methane with the remaining constituents being carbon dioxide and other minor and trace compounds of varying toxicity. Although the methane production rate decreases over time, production can continue for more than 30 years.

The described landfill gas production pattern has been delineated by Farquhar and Rovers and is reproduced below in Figure 6-1.

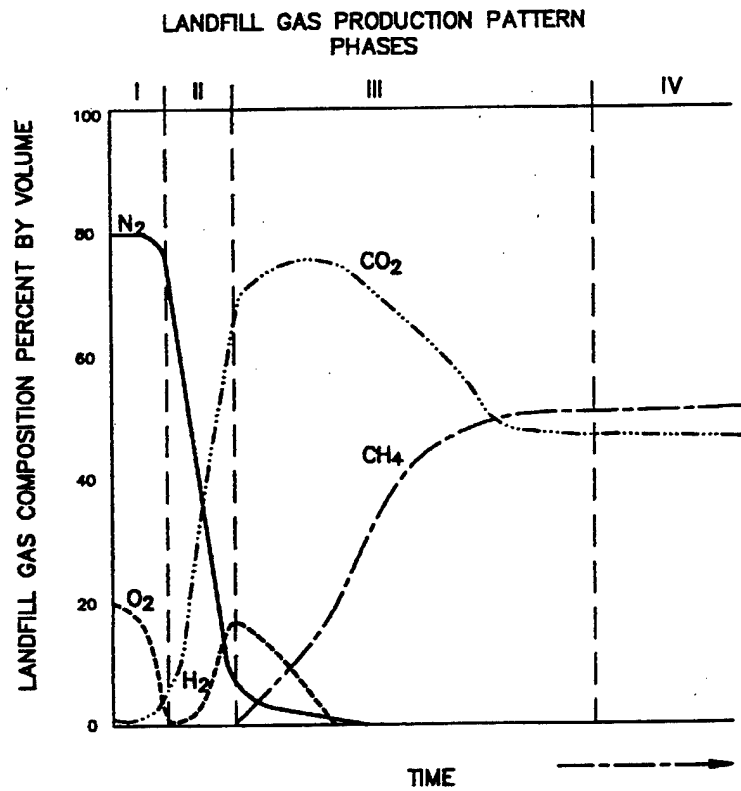

Figure 6-1. Landfill Gas Production Pattern (Source: 10, p.72, Figure 4.8)

The typical composition of MSW landfill gas is shown below in Table 6-1.

**Table 6-1. Typical Composition of Landfill Gas**

Component	Percent (dry volume basis)
Methane	45-60
Carbon dioxide	40-60
Nitrogen	2-5
Oxygen	0.1-1.0
Sulfides, disulfides, mercaptans, etc.	0-1.0
Ammonia	0.1-1.0
Hydrogen	0-0.2
Carbon monoxide	0-0.2
Trace constituents	0.01-0.6

**Source:** (1, p.382, Table 11-2)

It is important to note that Figure 6-1 does not show specific timeframes nor does Table 6-1 show exact percentages. This is because various factors affect the production timing, production rate and composition of landfill gas. The main factors are moisture content, waste composition, temperature, acidity or alkalinity, availability of nutrients, and soil type; moisture content appears to be the most influential parameter factor (27, p.19). These factors will vary by location, season and regulatory climate (27, p.10). The production parameters may also vary within a particular landfill because of varying compositions and waste deposit times. The potential consequences of landfill gas, both hazardous and beneficial, depend on its composition and production rate. These parameters must, therefore, be modeled and estimated with the aforementioned factors as key inputs.

## Landfill Gas Hazards

The inevitable presence and dynamic characteristics of landfill gas present a very real hazard potential. This risk must be appreciated since death and property damage can result if the gases are not properly controlled.

Methane gas, being the primary and seemingly most dangerous component of landfill gas, is odorless and colorless with a density less than air. The gas, therefore, has a tendency to rise and accumulate undetected. Landfill gas can typically leave a landfill through migration into adjacent soils, on-site structures or through atmospheric emissions (28, p.2-2). Figure 6-2 shows possible landfill gas escape paths.

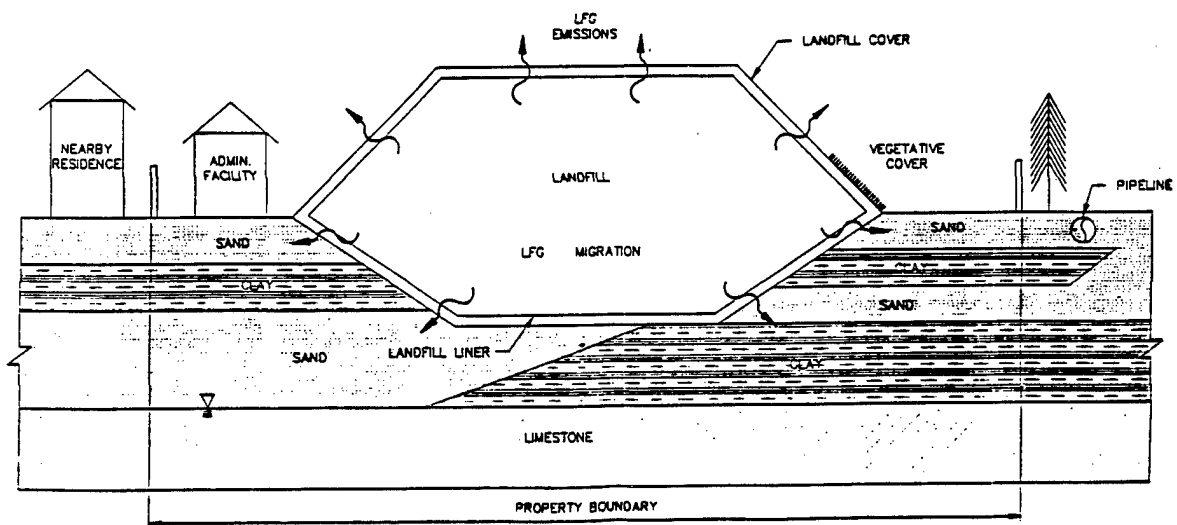

Figure 6-2. Landfill Gas Migration Pathways (Source: 28, Exhibit 2-1)

Before impermeable covers were required, the gas could readily diffuse through the cover layers. With the onset of impermeable covers to prevent infiltration of moisture, the gas is forced to transverse laterally through the landfill, potentially migrating off site. If the gas is not properly controlled, post closure re-use options can be adversely affected by the following hazards:

1. *Explosion.* This hazard is probably the most publicized. The uncontrolled movement of methane laden landfill gas can lead to its collection in confined spaces within nearby structures. When methane is combined with air in the range of 5% to 15% by volume, the mixture becomes explosive (29, p.362). Above this range, the methane/air mixture will burn thus posing a fire hazard (30, p.65). There are many cases where property damage or personnel injury has resulted. One such event occurred in the 1970's when migrating landfill gas caused an explosion at a National Guard Armory in Winston Salem, N.C., killing three occupants and injuring twenty-five. The closest section of the armory concrete block construction was about thirty feet away from the landfill. The facility was built on a six inch reinforced concrete slab (3, p.127; 28, p. 2-1). The migration of gas into the building may have been aggravated by the recent placement of additional cover material on the waste (30, p.66). Most of the documented incidents occurred prior to the requirement for impermeable liners and gas control systems.
2. *Toxicity.* The trace constituents present in landfill gas have the potential of acute and chronic toxicity. Many of these constituents, at sufficient concentrations, are known or suspected human carcinogens (28, p.2-1).
3. *Asphyxiation.* Methane and carbon dioxide are both asphyxiants and present a hazard in closed structures where landfill gas has a tendency to silently accumulate and deplete the oxygen concentration (28, p.2-1).

4. *Odors.* Trace compounds such as hydrogen sulphide and complex organics can cause unpleasant odors as emitted (29, p.362).
5. *Vegetation damage.* Migrating landfill gas displaces oxygen from the root zones in the vegetative cover and can result in extensive die-off (29, p.362).

The degree of hazard risk will depend on the gassing characteristics of the landfill, the effectiveness of natural or synthetic barriers in place, and the sensitivity of the proposed and/or existing developments (29, p.363). These factors must be carefully evaluated. Evaluation will include testing and modeling the gas production and migration potential. The results will form the baseline and gauge the effectiveness of possible mitigating techniques (10, p.382).

#### **Control Measures**

Fortunately the aforementioned hazards can today be minimized through innovative design and strategic placement of gas control systems. There are various ways to effectively collect and disperse, or reutilize, the gas, creating a safe environment for beneficial re-use. Any control system, however, needs to be designed with an adequate margin of safety which reflects the following items (29, p.363):

1. The inherent characteristics of landfill gas
2. The reliability of the measured gas concentrations and emission rates
3. The durability/serviceability of the control system during the design life the development
4. The proposed end-use of the landfill

Measures for controlling landfill gas can be classified as either controls for preventing lateral migrations beyond the site boundary or controls for preventing migration into confined spaces within building structures (29, p.363). Control measures can be further classified into passive and active systems. Passive systems provide an engineered pathway for the gas to safely vent to the atmosphere, relying on the inherent tendency of landfill gas to take the path of least resistance. Active systems, on the other hand, incorporate the use of energy to extract the gas from the landfill. A blower is typically used to create a vacuum, drawing the gas through a collection network. The gas is then routed to a flare or a reutilization facility. The use of a blower driven pumping system represents a transition from the passive to active type (10, p.403).

#### **Prevention of Lateral Migration**

Use of a passive system for this purpose is most suitable where gas generation is low, off site migration is not expected, and odors are not an issue (12, p.222). Passive systems can be employed either within the landfill, around the perimeter, or both. An effective passive system designed to prevent lateral migration of gas will typically have the following components:

1. A gravel trench with a perforated vertical vent pipe, facilitating exhaust to the atmosphere (1, p. 403). See Figure 6-3 [a].
2. A perforated horizontal collector system, connecting the vertical vent pipes (12, p. 223). See Figure 6-3 [b]. Integration facilitates transition to an active system (10, p. 403).
3. A barrier system to further dissuade migration (28, exhibit 4-11). See Figure 6-3 [c]. In modern landfills, regulations will often require a liner which will act as a barrier to migration.

4. Where the depth of gassing material is in excess of five meters, gas wells may be required, constructed to the full depth of the gassing fill (29, p.365).

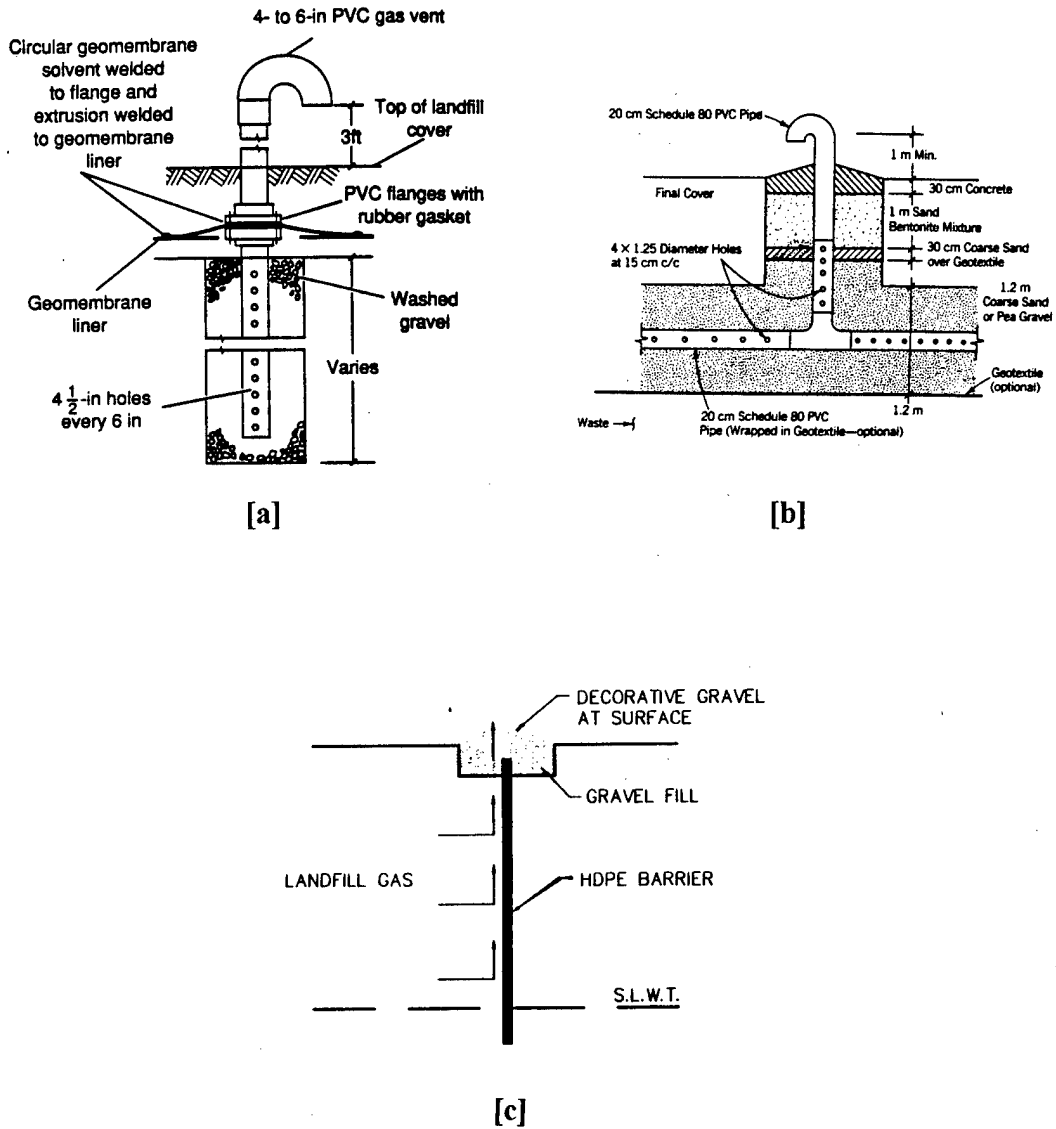

Figure 6-3. Passive gas control measures: [a] gravel trench with vent pipe (Source: 1, p.403); [b] horizontal collector system (Source: 12, p.223, Fig. 8-29); [c] barrier system (Source: 28, Exhibit 4-11).

The use of an active gas control system is more applicable to development of a closed landfill, especially where public use will be commonplace. Although more complex and costlier, an active system reduces the potential for migration, provides the capability for conversion of gas to fuel or energy, and minimizes detrimental effects to air quality and the emission of odors. Air quality has most recently become a factor with the promulgation of MSW landfill emission standards by the EPA effective March 12, 1996 (31). The EPA has determined that "municipal solid waste landfills cause, or contribute to, air pollution that may be reasonably anticipated to endanger public health or welfare" (31, p.9905). If a landfill emits above standard concentrations, an active gas collection system, meeting published performance standards, may be required (31).

Active systems are preferred whenever any of the following conditions exist: the MSW age is less than twenty years, the depth of the MSW is greater than ten meters, or the development to be protected is less than one-half kilometer away from the landfill (10, p.401). An effective active control system designed to prevent lateral migration of gas will typically have the following additional components (1, pp.406-411; 32):

1. Series of manifolded pipes connected to extraction wells or vent trenches
2. An exhaust blower that discharges into a combustion device such as a flare, or into a treatment facility for reutilization.

This type of system will usually be a combination of wells within the landfill and on the outside of the landfill [See Figure 6-4]. The placement and performance standards of the system are based on the results of gas testing and modeling, risk factors, and regulatory requirements.

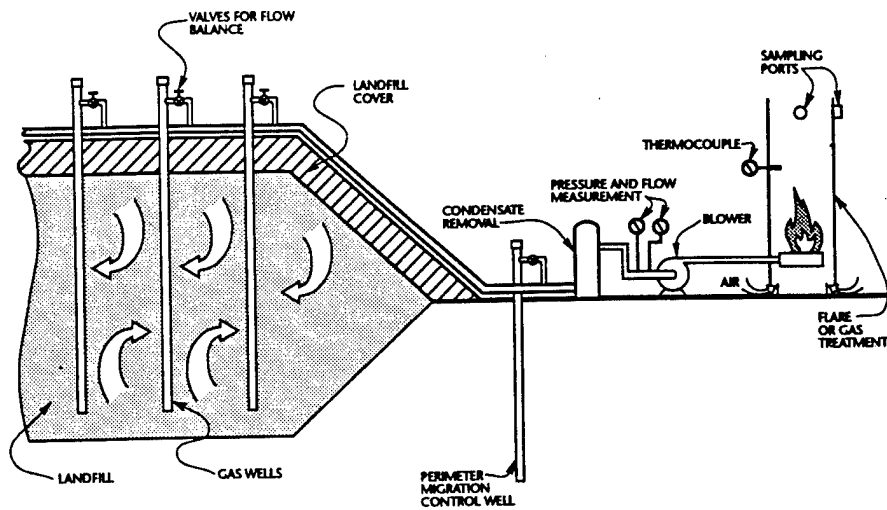

[a]

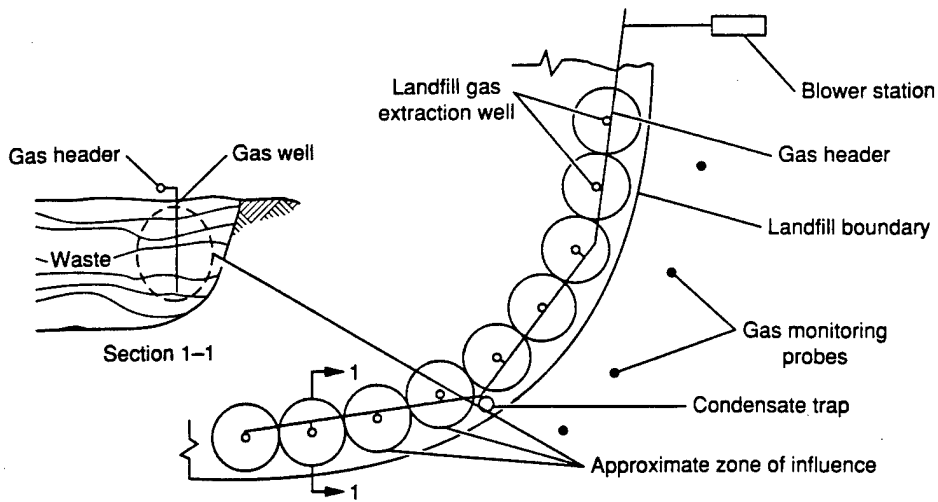

[b]

Figure 6-4. [a] Active Landfill Gas Control System, elevation view; (Source: 32)  
 [b] Active Landfill Gas Control System, plan view;  
 (Source: 1, p.407, Fig. 11-19)

### Prevention of Migration into Structures

If building structures are to be constructed on or near the landfill, the above controls are not adequate to protect lives and property. Card (29, p.68) claims that the safest approach to the potential of gas collecting in buildings erected on landfill sites is simply to avoid building on MSW. Although this viewpoint cannot be argued, there are construction techniques that can be used to greatly minimize the risk. These techniques may also be applied to structures that are built around the landfill site as part of a recreational development. Secondary control measures must be introduced around the structure itself. One of the primary barriers to gas migration into a structure is a floor system where cracks, construction joints, and penetrations in the slab are minimized and properly sealed (33, p.58).

The following measures are considered essential:

1. The floor slab should be cast in excellent quality concrete and incorporate an impervious geotextile membrane (28, exhibit 4-16; 29, p.366). See Figure 6-5[a]
2. Service ducts should not penetrate the slab. All services should be routed around the edge of the slab. Any service that must go through the ground slab should incorporate a specially-designed 'boot' to maintain a gas-tight seal (28, exhibit 4-17; 29, p.366). See Figure 6-5[b].
3. Install an audible methane detection and alarm system that is tailored to each structure's use, form of construction, and possible entry points for gas migration. Sensors should be located in susceptible locations such as poorly ventilated spaces within and beneath buildings, and linked to a central display and alarm panel (29, p.371).
4. Incorporate an air space or gravel bedding beneath the slab (30, p.68).

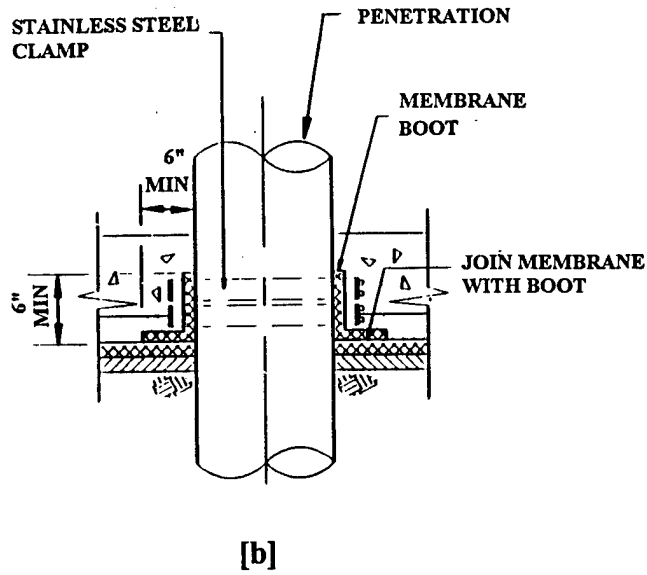
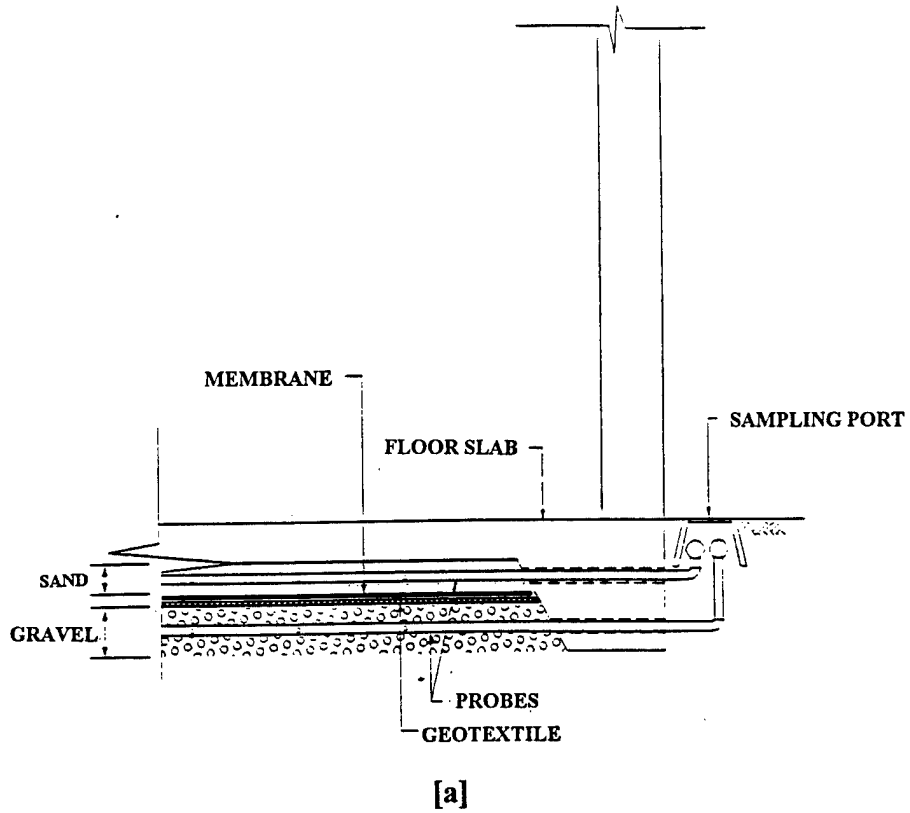

Figure 6.5. [a] Sub-Slab Geotextile Membrane (Source: 28, Exhibit 4-16)  
 [b] Utility Service Penetration Through Slab (Source: 28, Exhibit 4-17)

The venting of this medium can be passive or active, depending on the mechanism utilized. If passive venting through an air space is chosen, air bricks can be placed between the floor slab and the surface of the ground. If the air space is backfilled with gravel bedding, PVC vents are placed in the bedding. These vents are connected to risers that ventilate the gases above the roof of the structure. (28, p.4-7, Exhibit 4-15; 29, p.367; 30, p.68). See Figure 6-6.

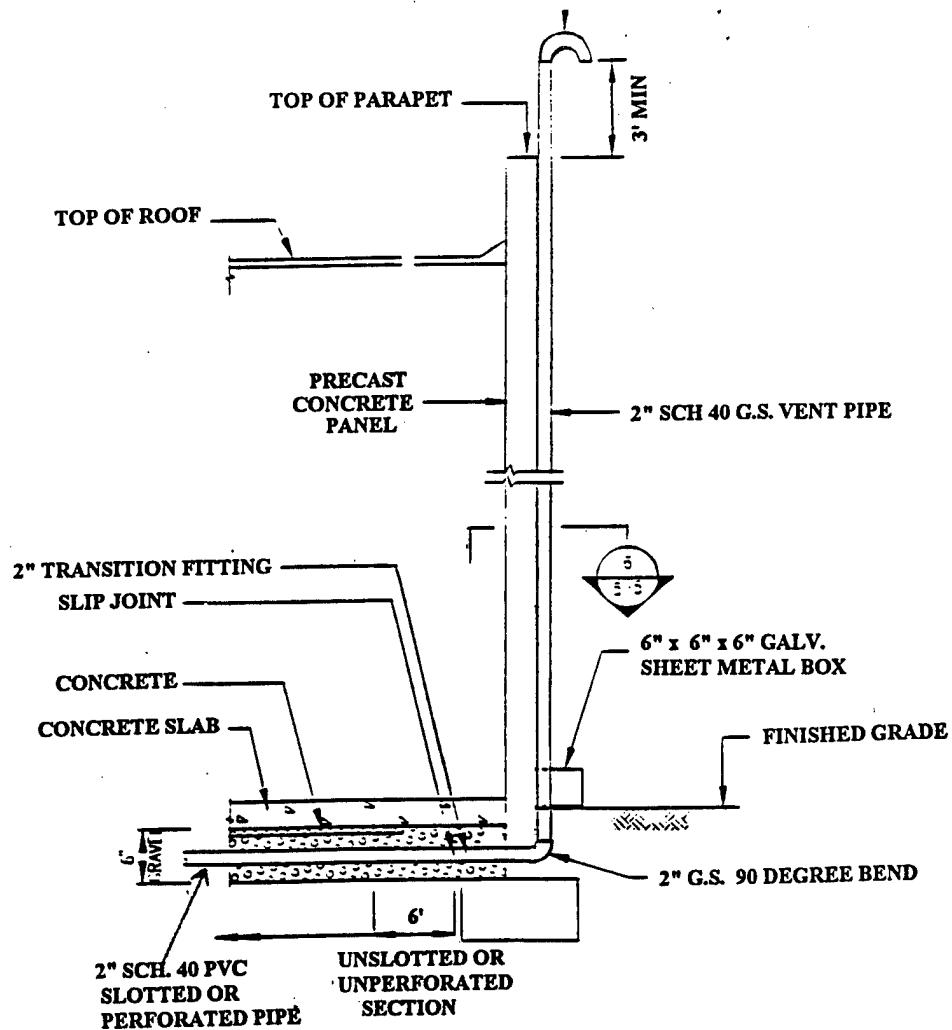

Figure 6-6. Sub-Slab Landfill Gas Vent (Source: 28, Exhibit 4-15)

Forming a ventilated void space requires the use of costly suspended ground slab construction. The gravel bedding option offers a compromise (29, p.367). The passive venting system should be designed to keep gas levels from approaching regulated design concentrations (29, p.366).

The use of a roof blower constitutes active extraction (33, p.59). The collected gas will most likely be vented to the atmosphere using a riser similar to that shown in Figure 6-6. An active system could be activated by gas sensors within the ventilation void (29, p.367). Because of the maintenance and testing requirements and the possibility of accidental failure, exclusive reliance on continuous active venting is not considered suitable to prevent the accumulation of gas beneath buildings. A more appropriate control technique would combine a gas-resistant membrane, continuous passive venting, and an audible detection and warning system (29, p.367). Well designed active collection systems and reliable barriers within the landfill will also continue to decrease the risk of gas migration into buildings.

#### **Beneficial Recovery of Landfill Gas**

With an active gas control system most likely being the best solution to protect the public and increase development options, one must decide what to do with the collected landfill gas. One option is to thermally destruct the gases through a flaring facility (1, p.413). Although a common method, flaring does not put the gas to good use. Since the typical composition of landfill gas is half methane and half carbon dioxide, it is a potential fuel supply (10, p.413). "Methane recovery provides public and private entities an opportunity to convert a previously untapped resource and landfill hazard into both a productive fuel and revenue source" (10, p.413). Figure 6-7 shows a simplified layout of a gas recovery system.

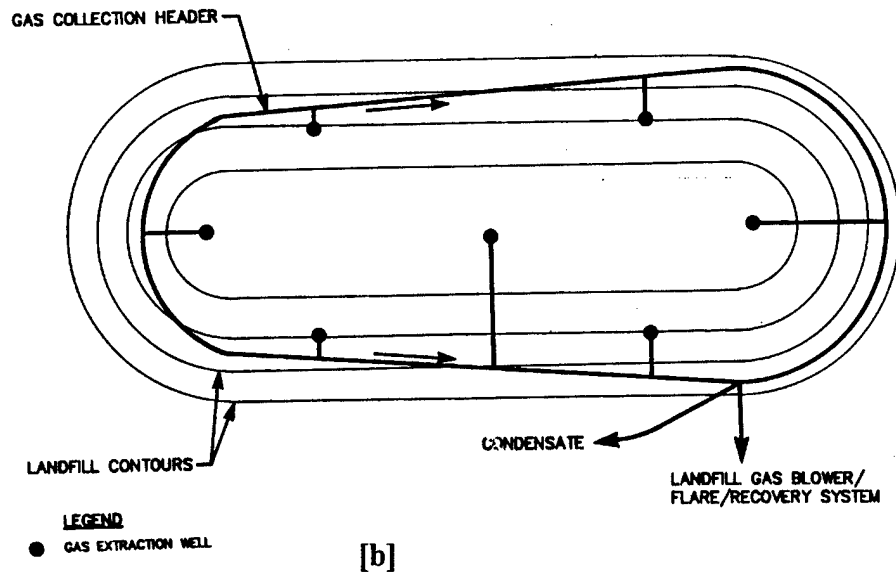
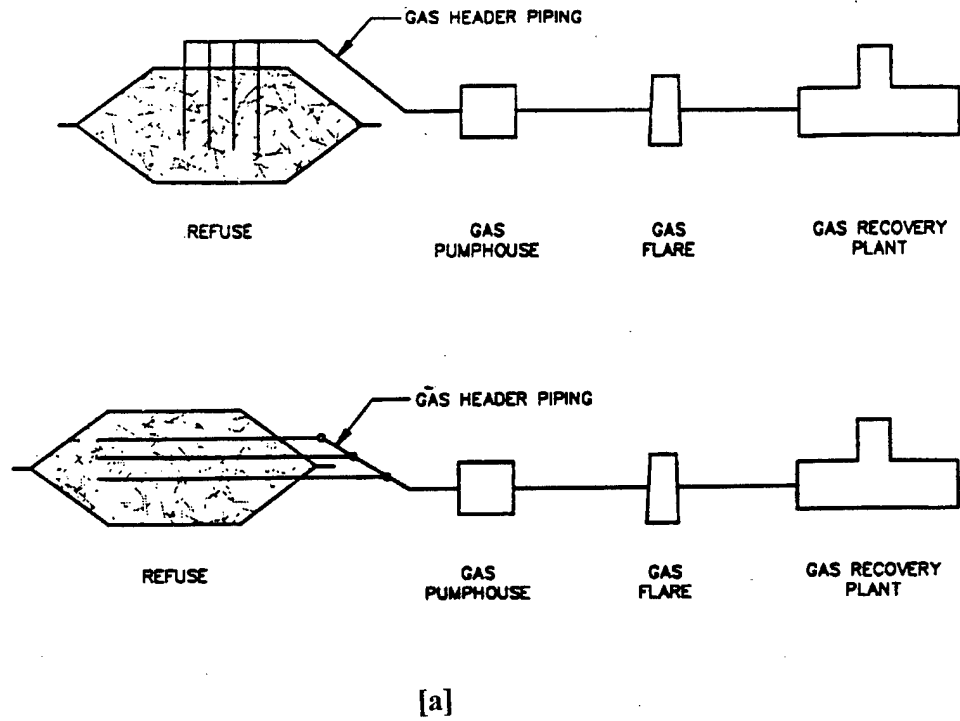
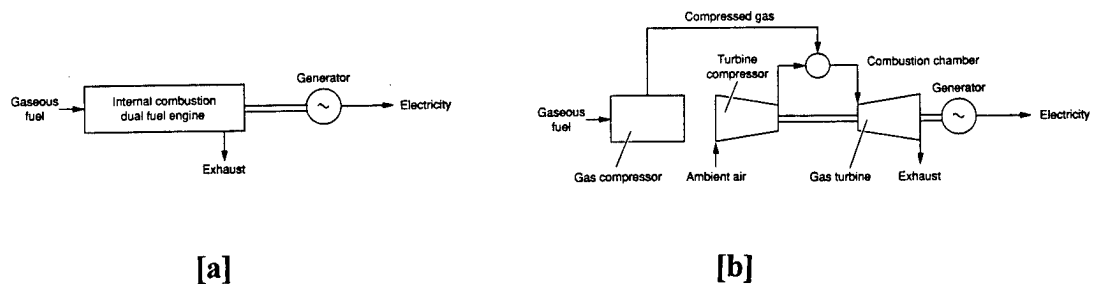

Figure 6-7. [a] Layout of Landfill Gas Recovery System, elevation view  
 (Source: 10, p.418, Fig. 14.2)  
 [b] Layout of Landfill Gas Recovery System, plan view  
 (Source: 10, p. 420, Fig. 14.4)

The feasibility of recovering landfill gas is very site-specific. Factors include quantity and quality of recoverable gas, the availability of a market within a practical radius, and the unit price obtainable for the energy product. For a recovery system to be viable, it must involve a landfill with a minimum in-place waste quantity of 500,000 to 1,000,000 tons and a minimum depth of fifteen meters (10, p.414).

There are proven methods available to treat and convert the generated gases to fuel, heat or electricity for a variety of end-uses. Uses can vary from heating an adjacent supporting facility to supplementing a power generation facility. Three alternatives are normally considered (32):

1. Direct use of the raw landfill gas to fuel a nearby boiler or for space heating. This may require compression of the gas and construction of a dedicated pipeline.
2. Use of the gas in an engine-generator or gas turbine-generator set to produce electricity on the landfill site. Figure 6-8 shows a layout of such systems. Arrangements can be made with the local utility to purchase the generated power.
3. Remove the carbon dioxide and other impurities from the gas and sell it to a natural gas utility.



**Figure 6-8.** Flow Diagrams for the Recovery of Energy from Landfill Gas: [a] using internal combustion engine and [b] using a gas turbine (Source: 1, p.416, Fig. 11-29).

In a mid 1980's survey of methane recovery facilities in the U.S., a majority used the gas produced to generate electricity on site; the average facility produced 1.9 mega-watts of electric power (10, p.431). The use of the gas by public utilities will today depend on the profit potential. A study by Pernicano (34) at the University of Florida in 1993 concluded that the best alternative for landfill gas utilization, at the Alachua County, FL., Southwest Landfill, is for direct use of the methane as a vehicle fuel; the methane for fuel resulted in the highest Net Present Value because of lower capital and operating costs and relatively high energy retention (34, p.2).

Moisture, combustion temperatures, and compositions will have to be controlled in order to preserve efficiency and equipment (6, pp.416-417). Landfill gases that are 50-60% methane hold the most promise as an energy source, but must be processed to at least remove the liquids that condensate when the saturated gases are compressed (27, p.35). Problems that commonly occur in gas collection processes are air intrusion into the gas collection equipment and the accumulation of condensate in the header pipes (34, pp.19-20). Either problem can result in operation and efficiency problems.

Processing can vary greatly in nature and extent as well as in capital, operation and maintenance cost. "Choosing which option to pursue requires reliable projections relating to product costs, risks, and returns" (10, p.425). The quality and generation rates of the methane gas are critical in assessing the viability and cost effectiveness of gas recovery. Gas testing and modeling should be carried out before any long-term investments are made. If the landfill's gas production is questionable, beneficial recovery is unlikely. The following case studies show that successful recovery is indeed possible.

### **Industry Hills Landfill Gas Recovery Case Study** (35, p.66)

Although there are many examples of gas recovery success stories, a review of the system implemented at Industry Hills Recreation and Conference Center in California presents a large scale recovery in a regulatory stringent state. The 617 acre site, of which approximately 155 acres were used for a sanitary landfill, houses two 18- hole golf courses, a conference center, an olympic-size swimming pool, a tennis complex, an equestrian center, a laundry facility, and an 11-story, 248 room hotel. Landfill gas management was effectively incorporated into the design of the facility and consists of two primary systems. The first prevents the accumulation of methane gas beneath on-site structures and methane migration beyond property lines. Landfill gas is collected then destroyed in a blower/flare station. The second system is designed for landfill gas recovery. The energy potential of landfill gas is fully capitalized at Industry Hills by fueling water heaters and boilers at the swim/tennis complex, laundry facility, and the conference center. The gas is processed to remove liquids, pressurized, and distributed to the various end user locations. A significant portion of the development's energy demands are met by the recovery process. The natural gas bills at Industry Hill are typically reduced by approximately \$15,000 to \$18,000 per month.

### **Venice Park Landfill Gas Recovery Case Study** (36, p.42)

Venice Park Landfill in Michigan is an eighty acre site that successfully supports a co-generation methane gas plant. The gas is collected through a series of thirty to fifty foot wells and a horizontal collection system. A compressor pulls the gas through a series of valves and flow measuring stations on the way to a cooling and drying unit. Two Caterpillar engines then use the gas to power two generators that produce nearly 1600 kilowatts of electrical energy.

A layout of this system is shown in Figure 6-9. This energy is apparently enough to power over 1000 homes.

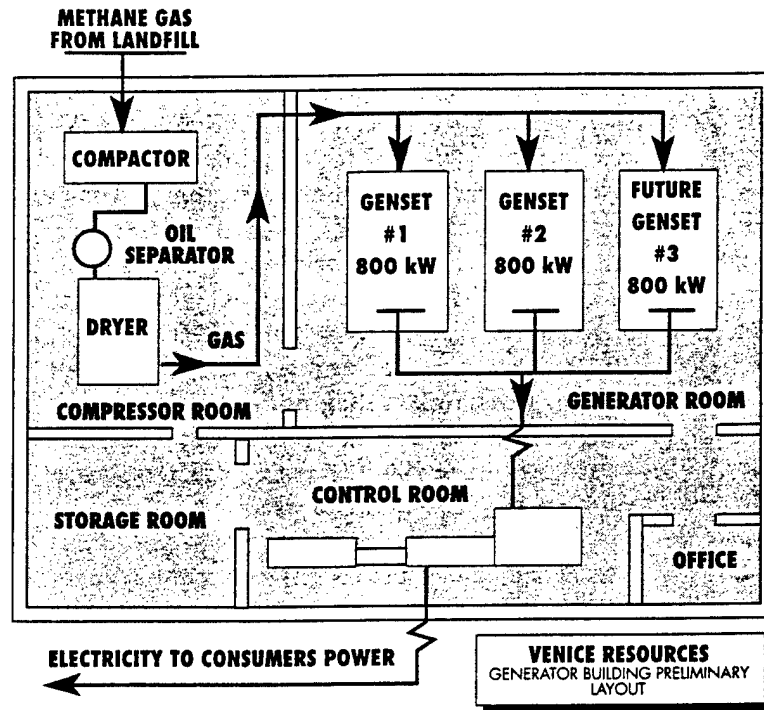

Figure 6-9. Venice Park Landfill Methane to Energy Plant (Source: 36, p.40, Fig. 1)

## CHAPTER 7 DIFFERENTIAL SETTLEMENT

The prospect of landfill settlement poses a challenge to development of closed landfills. Foundations can crack and collapse, utility lines can snap or flows reverse, gas and leachate collection systems can be compromised, and surface drainage patterns can be altered. Infrastructure must, therefore, be designed with techniques and materials to accommodate the predicted settlement magnitude and rate. Ignorance or avoidance of this inevitable phenomenon can result in serious damage and costly recurring repairs. Similar to gas generation, the settlement of a MSW landfill is dependent on many factors. Realizing the site-specific factors and taking them into consideration when planning post-closure uses is imperative.

### **Causes and Mechanics of Settlement**

The settlement of a landfill is primarily the result of a complex interaction between the following mechanisms (37, p.141; 38, p.51; 39, p.226):

1. Mechanical or physical compression through the reduction of void spaces or compression of loose material. Contributing elements include MSW self-weight and overlying loads such as landfill covers, engineered fill, stockpiled soils or foundation structures.
2. Raveling or movement of smaller material into larger voids. These voids can be caused by collapse, seepage, or vibrations.
3. Chemical decay of MSW by percolating waste liquids or leachate.
4. Biological decomposition.

The effect of these mechanisms depends on variables such as moisture, waste characteristics, initial MSW compaction, fill height, the volume of cover material used with respect to the volume of wastes disposed of, and the compaction achieved during construction (1, p.459; 39, p.226; 40, p.70). During the years that a typical landfill is in operation, waste streams and compaction rates will vary. This variation of the in-situ characteristics of a landfill will inevitably lead to differential settlement. The behavior of one landfill will most likely be different from that of another. Climate, moisture infiltration barriers, and age of the landfill will also cause significant variations.

Because of the complex composition of landfills and the differences between landfills, settlement characteristics, magnitudes and rates are very difficult to predict or stereotype. There have been various studies done on this topic. One opinion is that approximately 90% of settlement will occur in the first five years, although it may continue for twenty-five or more years at a slower rate (41, p.87). Total landfill settlements of 25% of the initial MSW fill thickness can be expected (37, p.142). Figure 7-1 shows how the degree of settlement can vary as a function of the initial compaction.

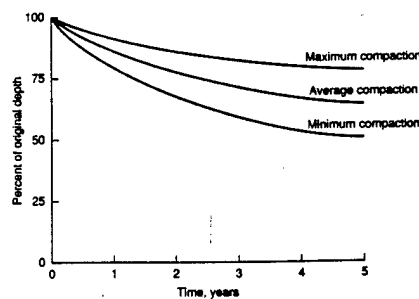

Figure 7-1. Settlement of Compacted Landfills (Source: 1, p.460, Fig. 11-56).

A logical conclusion is that settlement of landfills is definitely site specific and must be analyzed on a case by case basis.

### Analysis and Design Considerations

Before any development or reuse of a landfill site commences, careful study of related historical documents and the determination of site characteristics is essential. Critical documents that should be studied include original landfill grading plans, an existing topographic map, the landfill operations summary, an existing utilities and environmental control system layout and any evidence of previous uses (42, p.163). Once this base information is digested, the settlement potential of the landfill site must be estimated. Although the required analysis can be complex and sometimes inconsistent, the resulting data is indispensable to the design of adaptable infrastructure and landscaping.

Use of test fills is encouraged to assess compressibility of the landfill. In addition to the benefit of pre-loading the waste, test fills are effective for obtaining reliable, low cost parameters for the long-term behavior of the waste material. Test fills should be planned at least a year ahead of any construction (43, p.94).

The best substitute for a test fill is to survey site settlement at a number of permanent monitoring locations; monitoring should be done along at least two profiles across the landfill to provide an indication of differential settlement (37, p.145). Ideally, settlement monitoring would begin with landfill closure and continue for two years to provide a satisfactory amount of observed data to make predictions on future rates of settlement (42, pp.164-165). In the areas where construction of foundations is planned, a detailed sub-surface investigation may be warranted. Resulting data can lead to a more accurate representation of the area and ultimately better design recommendations. Once the settlement characteristics are projected

and the areas of pronounced differential settlement are identified, the site planning and design process can proceed with a renewed sense of confidence.

Based on the analysis, the development potential of the site can be assessed. The type of facilities that the landfill can support and the location of facility components must be determined. These important decisions are made realizing that the analysis will not be flawless. The areas that require particular consideration of differential settlement include structural systems, utilities and site improvements (42, p.171). The design of each one of these areas must incorporate an adequate level of safety and be comprised of components that will adapt to the long-term, uncertain movements.

#### **Mitigating Effects of Settlement**

All components of a prospective development on a closed landfill are susceptible to the effects of settlement. The major areas that must be addressed are structural systems, utilities and site improvements (42, p.171). Techniques and materials can be applied to each area that will minimize the risks to development and result in a beneficial venture for both owners and users. Although there have been failures in the past, the majority of them can be attributed to design and construction which failed to deal effectively with the unique characteristics of landfills (37, p.140).

#### **Structural Systems**

The potential detriment of foundation systems is an obvious concern when planning development on closed landfill sites. Figure 7-2 shows possible failure and settlement mechanisms. Structural supports can, however, be effective if they are tailored to the unique

characteristics of the site. The magnitude of total and differential settlement is the primary issue in the selection of foundations for landfill development (37, p.141).

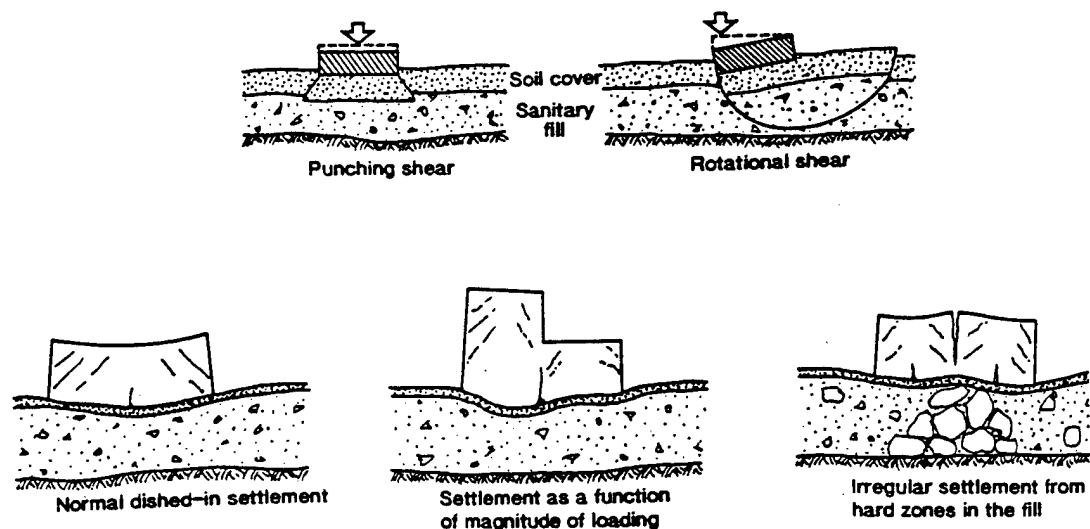

Figure 7-2. Failure and Settlement Mechanisms (Source: 44, p.195, Fig. 7)

Since settlement potential drives the foundation requirements, modifications to the site that can decrease settlement potential should first be evaluated. Modification options include (37, p.146):

1. Allowing the waste to reach an acceptable level of decomposition, either by delaying construction or enhancing decomposition by techniques such as leachate recirculation. If a development can be postponed until at least five years after closure, some of the problems can be minimized. Recreational developments can be phased over time, beginning with perimeter facilities shortly after closure, and planning on-site construction for a later date (26, p.259). At Salt Meadows Park in Fairfield, CT., passive recreation was proposed for the area around a recently closed landfill; when the landfill becomes more stable, an outdoor amphitheater complete with stage, bandshell, dressing rooms, storage rooms and restrooms is planned (45, p.59).

2. Supplemental compaction of the waste. This technique is normally limited to depths of less than three meters.
3. Preloading the site with heavy material, usually soil, and monitoring the settlement.
4. Dynamic compaction by dropping blocks weighing five to twenty tons from heights of 30 meters. Materials properly treated by this method can exhibit a higher bearing capacity with a reduction in primary settlement by 70% and secondary settlement by 50% (3, pp.189-191). The use of dynamic compactions must be evaluated in regard to possible damage of the cover system and environmental controls. Max Keech, Vice President/Principal of Brian Kangas Foulk, claims that "dynamic compaction is rarely useful within the main body of the landfill since it inevitably damages the barrier layer and creates its own boundary conditions at the limit of the compaction effort" (42, p.172).
5. Injection of lime-slurry grout or fly-ash.
6. Increasing the soil thickness used for final cover to overcome low bearing capacity. The minimum suggested soil thickness is 1.5 times the width of the structural footings (41, p.88).

Although the aforementioned pre-construction techniques are worth considering, the design and construction of an appropriate foundation system will strongly influence the success of the project. The two types of systems normally used are classified as either shallow or deep. Shallow foundation systems are cheaper, less complex and are generally preferred to support small, relatively light structures that can tolerate minor damage (44, p.194). The use of shallow foundations is largely dependant on the bearing capacity and settlement projections of the underlying fill. Common types of shallow foundations are depicted in Figure 7-3 and include conventional spread footings, reinforced concrete mats,

and grid foundations. Grid foundations consist of column footings tied together with system of grade beams and an integral concrete floor.

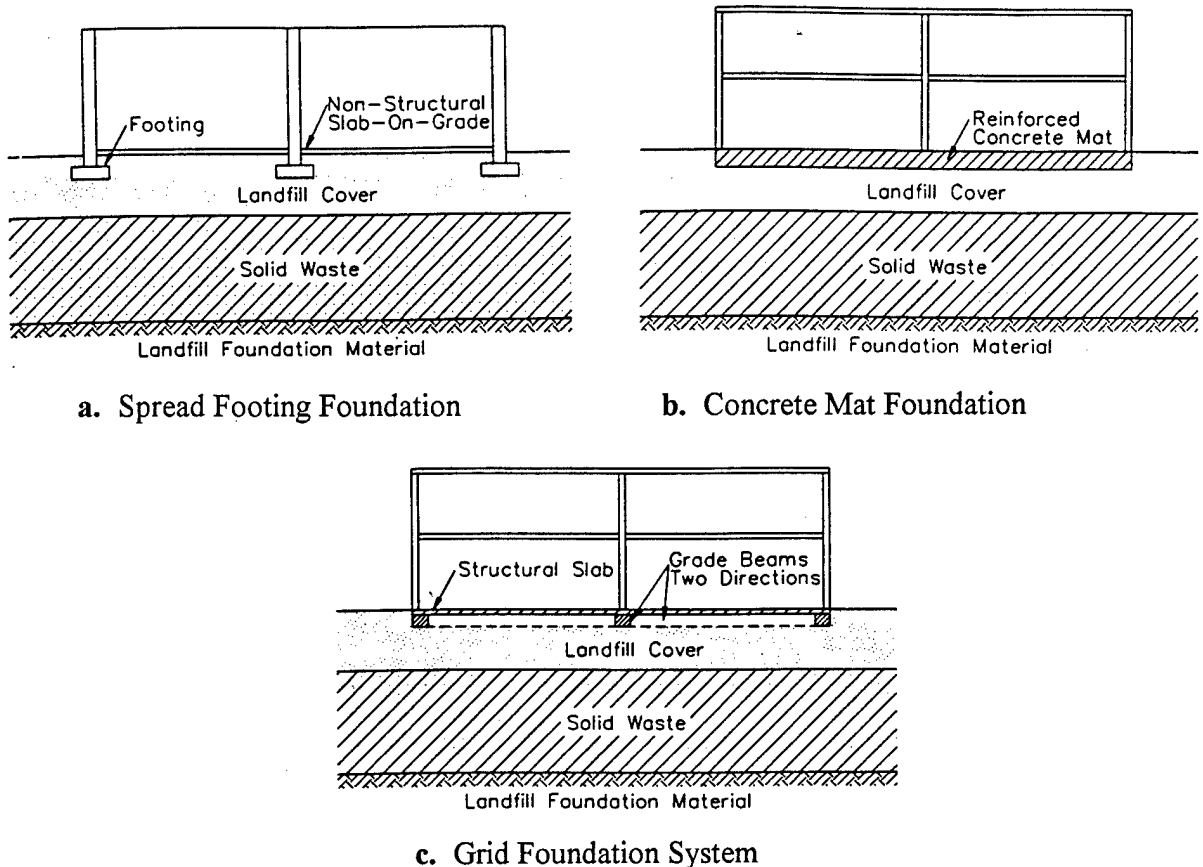

**Figure 7-3. Shallow Foundation Types (Source: 37, p.147, Fig. 2)**

Each of the listed foundations will be stiffened by additional reinforcing steel to compensate for the uncertainties of settlement at the landfill (37, p.148).

If the settlement projections are significant and the practicality or effect of site improvements is questionable, deep foundations should be considered. If large structures are planned, deep foundations are the most likely option. "Driven piles are the type of deep foundation system nearly always utilized to support larger structures constructed on closed

landfills" (37, p.148). Design of pile foundations on landfills must include analysis of the following issues (37, p.149; 44, p.197):

1. Required vertical and lateral pile capacity
2. Bearing capacity of underlying soils
3. Downdrag loads; Negative skin friction occurs when the settlement of the material surrounding a pile exceeds the downward movement of the pile shaft.
4. Constructability and construction impact on the landfill environment
5. Corrosion resistance of piles
6. Environmental protection and integrity of the liner and cover systems
7. Composition of landfill and potential obstructions
8. Water table level

Deep foundation design considerations are shown below in Figure 7-4.

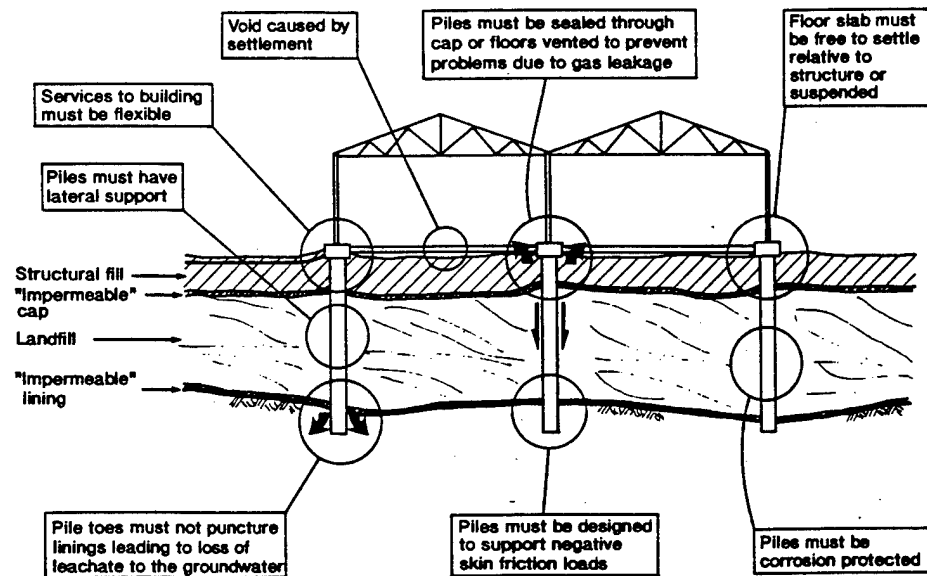

Figure 7-4. Deep Foundation Design Considerations (Source: 44, p. 197, Fig. 8)

Deep foundations are not a panacea and present additional challenges when considered in modern landfills with liner and cover systems. David Thompson of Halley/Aldrich feels that

“placing piles through landfills with both a cap and a liner is impractical” (46, p.51). Cost and constructability considerations surrounding piles favor light structures that can be supported by shallow foundations.

Regardless of the foundation system chosen, building interfaces will have to be designed to accommodate settlement. At these points, a vertical dislocation of 1.5 ft or more may be encountered (42, p.177). Methods used to mitigate boundary conditions at building interfaces include (42, pp.177-179):

1. Incorporate hinged slabs to allow angular rotation and accommodate desired access.  
See Figure 7-5.
2. Form exterior face of grade beams and footings to provide a smooth slip surface.
3. Set exterior edge of grade beams flush with building face.
4. Place foundations systems at a depth to be fully covered after anticipated site settlement; otherwise provide ‘skirts’.

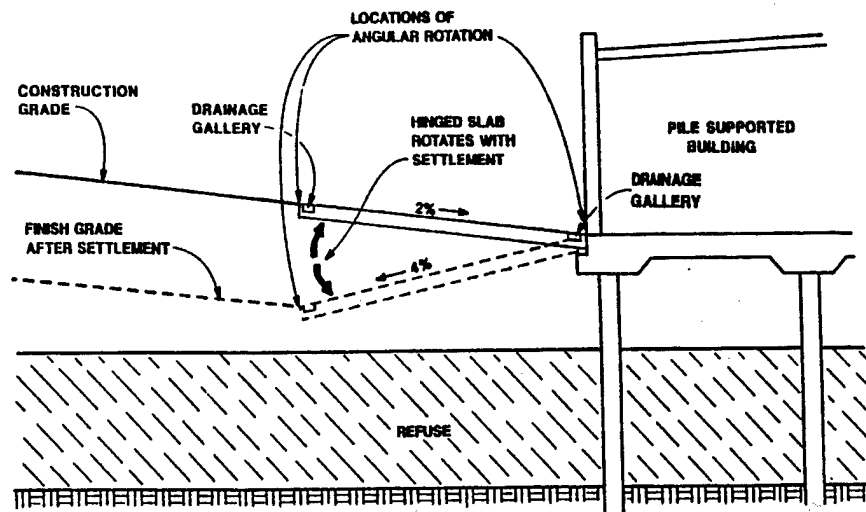
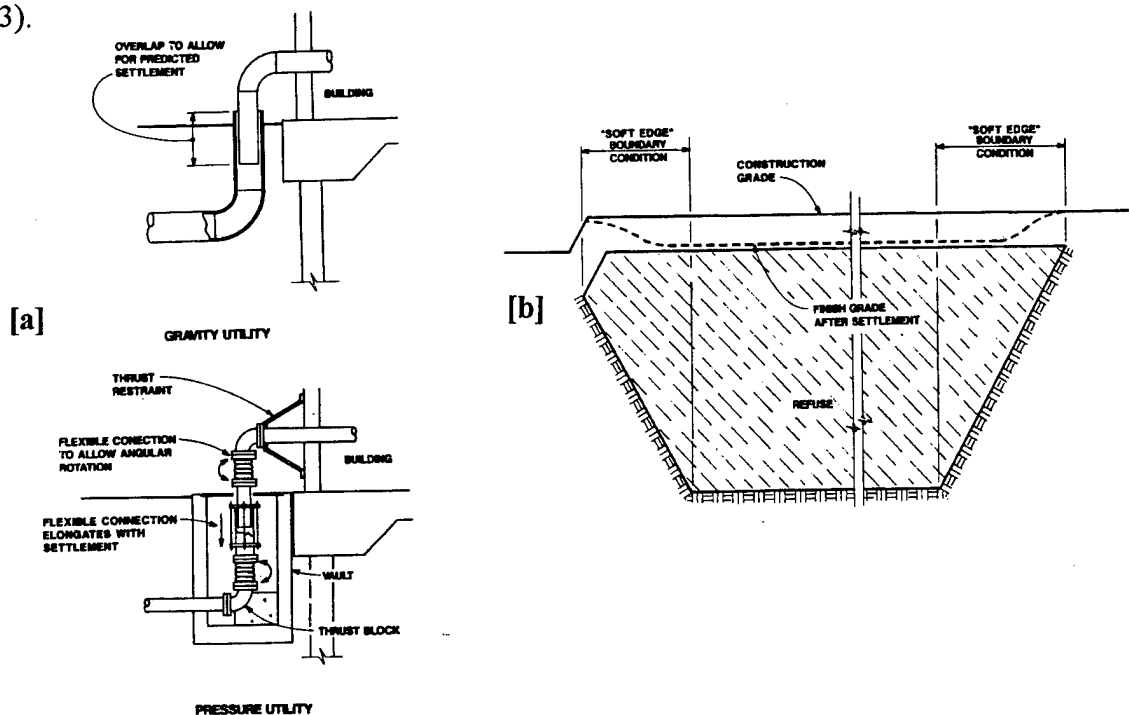

Figure 7-5. Hinged Slab at Building Entrance (Source: 42, p.178).

## Utilities

While specially constructed foundation systems may minimize the effect on the buildings, the area surrounding the structures housing the utility lines will continue to settle. The utility network that will serve a development is thus extremely susceptible to the effects of settlement. When planning end-uses, it is ideal to minimize utilities traversing through areas over the MSW fill. Where this is not possible, the utility lines will have to be designed with flexible materials and connections, as shown in Figure 7-6 [a], to account for the long-term differential settlement and vertical dislocation. Adequate gradients must be incorporated to preclude the reversal of flow as exhibited by the bowl phenomenon in Figure 7-6 [b] (42, pp.173-174). Since utility lines have been known to act as conduits for the migration of landfill gas, underground pipes should be adequately sealed to prevent entry of the gas (48, p.73).



**Figure 7-6.** [a] Flexible Utility Connections (Source: 42, p.179, Fig. 9).  
[b] Bowl Phenomenon (Source: 42, p.174, Fig.5).

Additional utility design considerations include (42, pp.174-176):

1. Incorporate overflow, leak detection and secondary containment as necessary
2. Install utility systems above-ground where practical
3. Minimize barrier layer penetrations through integration; Figure 7-7 [a].
4. Apply cathodic protection for corrosion control
5. Backfill utility systems beneath structural slabs with a non-cohesive backfill, such as pea gravel, to minimize dislocation; Figure 7-7 [b].

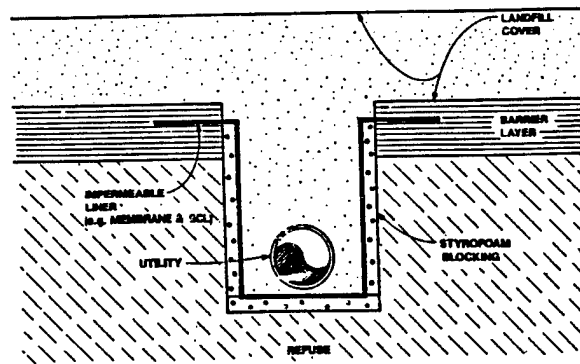

[a]

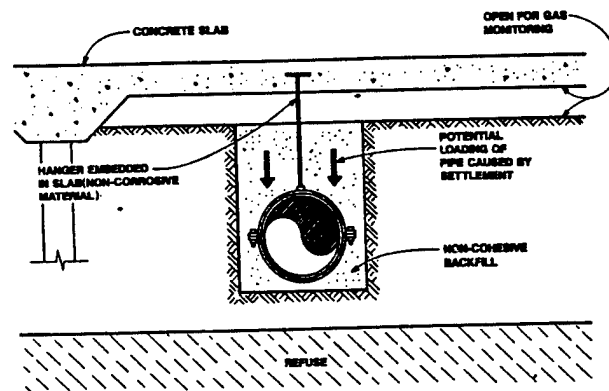

[b]

Figure 7-7. [a] Utilities Penetrating Landfill Barrier (Source: 42, p.176, Fig.7)  
[b] Utilities Suspended Below Pile Supported Slabs (Source: 42, p.180, Fig.10)

### Site Improvements

The final grade and drainage pattern of a site can also be adversely affected by differential settlement. Even a site with minimal structural or utility needs such as athletic fields can suffer damages. Changes in topography can cause drainage problems or slopes that render a facility unusable for its intended purpose. "Surface slopes must therefore be designed to provide appropriate slopes after settlement. It is generally good practice to slope surface improvements in the direction of increasing settlement to avoid future reversal of surface flow. Changes of 1%-2% in future surface slopes due to settlement are not uncommon on deep landfills" (42, p.171).

Additional precautions such as the use of a geotextile fabric have proven successful in minimizing damage. On a golf course in Hampton, VA. and on playing fields at Eldridge Park in Elmhurst, IL., such fabric was placed below the finished grade to reduce the potential for uneven settlement. The fabric reinforces the area, spanning any pockets of settlement that may continue to occur further down within the landfill (23, p.30; 49, p.84). If any pavements are planned for the site, flexible materials should be the rule. With advance planning, active monitoring, and preventive maintenance, site improvements are likely to support the intended end-use well into the future.

## CHAPTER 8 REVEGETATION

Landfill re-use at any level will require some form of revegetation effort. The reason for revegetation may be related to post closure regulatory requirements, erosion control, recreation needs, or wildlife attraction. Growing vegetation, whether it is grass, shrubs, or trees, on a closed landfill is more difficult than conventional planting. Landfill gas, a harsh environment and root restrictions are limiting factors which must be overcome. Success stories in the form of top quality golf courses, playing fields and refuges for wildlife are apparent across our nation. Success however requires technology, persistence, and innovation.

### Landfill Gas

Rising methane gas is probably the most notable impediments to growth. As evident in confined spaces, methane has the tendency to displace oxygen. This characteristic applies when methane gas is allowed to build up in vegetative soil. Oxygen is depleted and the root zones become anaerobic, stunting growth and contributing to die-outs. Although methane is not itself a toxic gas, the other major constituent of landfill gas, carbon dioxide has been shown to be directly toxic to plants (1, p, 779). If an impermeable cap such as clay or a geosynthetic membrane is installed as a cover component, in addition to a gas collection system, the risks of landfill gas related damage are minimized. Although very unlikely in today's regulatory climate, a landfill that is not vented or does not have an active gas recovery system will not support tree growth; meadows of native grasses and wildflowers will be more adaptable (50, p.58).

Additional gas inhibiting measures where vegetation is critical to habitat, aesthetics, or function include supplementing the cover with a layer of high quality topsoil. This amendment can enhance oxygenation and provide better support of root systems and growth habits of larger vegetation (51, p.51; 52, p.67). Research has shown that with topsoil, net methane concentrations have decreased, emphasizing the importance of these cover elements in site restoration strategies (53, p.335). Any measure that isolates the roots from methane will increase the survivability of plant varieties. Figure 8-1 shows designs that can protect plants from methane gas intrusion.

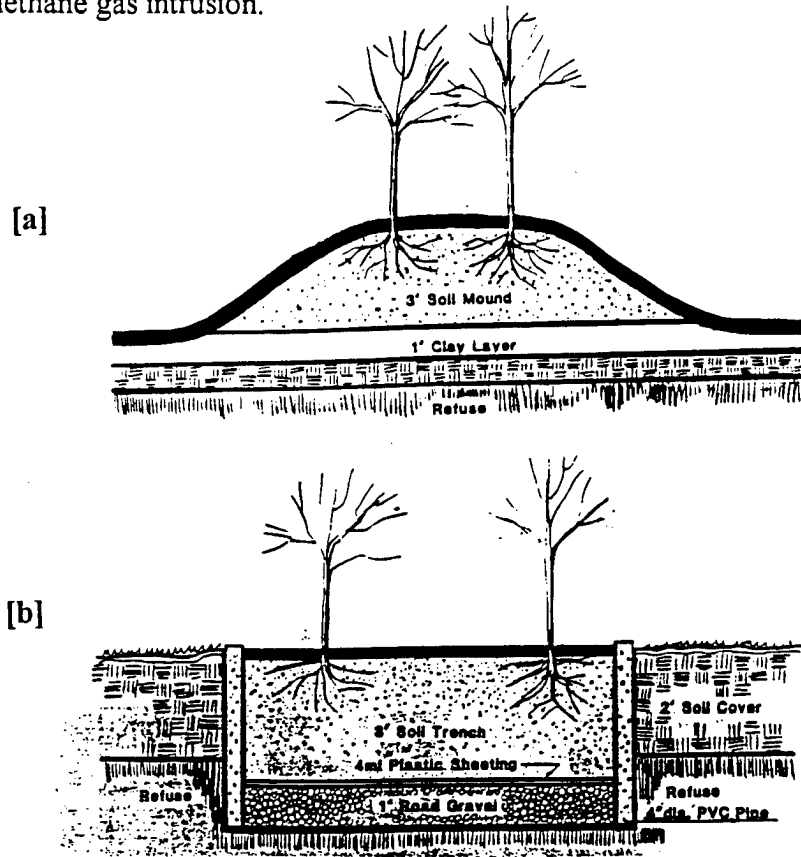

Figure 8-1. Designs to protect plants from methane intrusion; [a] berm, [b] trench (Source: 45, p.60).

### **Landfill Cover Penetration**

Even though an impermeable cover is a sure way to protect plants from landfill gas, the possibility of deep roots damaging cover systems is a concern. The safest way to avoid this possibility is to plant vegetation that inherently has shallow and laterally spreading roots. "There are numerous medium and small trees with fibrous root systems that will not injure the integrity of the cap system" (50, p.58). Such species also have the benefit of maximizing slope stability and preventing erosion and scour (54, p.246). On Staten Island, N.Y.'s Fresh Kills- 'the world's largest landfill'- a project to re-establish native woodland communities has provided encouraging news. Eighteen woody native species were planted on a six acre demonstration site and several years later, the clay cap remained in tact, undisturbed by tree roots (55). "Recent research by Rutgers University indicates that landfill caps engineered with hydraulic conductivities of  $10E-7$ cm/sec are a deterrent to root penetrations" (54, p.244). Such conclusions further promote revegetation possibilities.

### **Landfill Environment**

Besides the hazards of landfill gas and limitations on root depth, the landfill environment presents additional harmful elements such as drought conditions, high winds and poor soil composition. Although some of these elements are inherent to a landfill, revegetation can be facilitated through research, planning and proper introduction of native plant communities. "Poor planting practices can actually be more hazardous than adverse landfill conditions" (56, p.80). The process should not be hastily executed. The end-use and site specific conditions and characteristics must be first considered. "Unless the closed landfill is used for golf courses or other intensive uses, every effort should be made to blend the closed landfill into

the natural surroundings” (1, p.788). “Rather than planting foreign species and trying to sustain them, mimicking natural communities provides a lower cost framework which over time will withstand drought, infestation, blight and harsh conditions more successfully” (57, p.15). Whatever the choice for vegetation, proper planting techniques, required soil amendments and aggressive maintenance is required for success. The developer must not hesitate to consult experts in the field.

### **Revegetation Steps**

Prioritized steps to accomplish revegetation are (1, pp.789-790; 41, p.90, Table 2):

1. Coordinate project with experts involved in end-use planning.
2. Determine depth of cover; cover soil must be at least 60cm deep for grass establishment and 90cm for trees.
3. Implement erosion control program.
4. Determine soil nutrient status and bulk density.
5. Identify landfill tolerant vegetation types and their availability.
6. Prepare site (additional cover, environmental control devices, drainage).
7. Apply soil modification.
8. Plant grass and ground covers, considering seasonal constraints.
9. Monitor for growth patterns for at least one year.
10. Develop tree and shrub growth.
11. Monitor and maintain.

Proactive revegetation techniques will lead to an aesthetically pleasing, stable, and functional environment that can complement a variety of uses.

## CHAPTER 9 RECLAMATION AS A PROGRESSIVE OPTION

To this point, this guide has focused on the considerations that must be taken when planning for post-closure re-use of a landfill. Even though a closed landfill can undoubtedly become a community asset, closing a landfill inevitably means financial outlay and the need for an alternate disposal site. Emerging reclamation technology throws an inviting twist into options for a landfill that is approaching closure. Landfill reclamation is a process of excavating a landfill using conventional surface mining technology to recover recyclables, soils and the land resource itself (58, p.60). With closure and post-closure costs being potentially exorbitant and siting so complex, reclamation can be viewed as the ultimate re-use strategy. "Peter Block, of Browning and Ferris Industries [BFI], Houston, contends that the landfill problem is such that closing is the last option" (59, p.46).

### Benefits of Reclamation

By reclamation, the landfill is in effect being recycled. "In addition to reclaiming valuable resources, the recovered site can either be upgraded into a state of the art landfill, closed, or redeveloped for some other purpose" (58, p.60). The potential benefits of landfill reclamation include (60, p.33; 61, p.83):

1. Extending the life of existing landfills.
2. Reducing the need for siting new landfills.
3. Reclaiming marketable recyclables, particularly metals, soils, organics and plastics.
4. Installing liners, leachate and gas collection systems in old landfills.
5. Allowing inspection of landfill liners and permit repairs.

6. Reducing the footprint of the waste, thereby reducing closure costs and increasing the land available for conventional development.
7. Removing an entire landfill to end liability.

Communities have successfully reduced the sizes of landfills, extended their life and in some cases completely eliminated the landfill. A landfill in Edinburg, N.Y. was reduced from five to two acres, while in Hague, N.Y., a seven acre landfill was completely removed and the land reused for recreational purposes (62, p.40). In Fairhaven, MA, a 23-acre landfill is being mined with the expectation of providing enough room for twelve more years of garbage (63, p.16). "By either consolidating waste or removing it entirely, reclamation replaces or complements existing landfill closure and capping methods" (62, p.42). "Reclamation of 80% of the original landfill capacity is reportedly achievable" (58, p.60). The first and one of the most renowned reclamation projects in the U.S. completed the reclamation of 26 acres in 1994. This Collier County, FL. program has saved five million dollars through landfill cover re-use, sale of metals and recovery of disposal capacity (61, p.83). Collier County's method of reclamation is shown in Figure 9-1. Mining can be accomplished on a smaller scale in order to make a section of a landfill more suitable for construction or revegetation. The excavated waste can be replaced with more stable supporting fill.

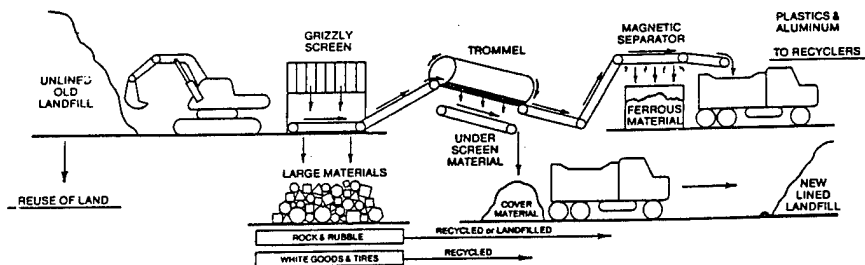

Figure 9-1. Landfill Reclamation, Collier County, Florida (Source: 64, Schematic)

### Concerns Regarding Reclamation

Reclamation through mining appears to be an inviting option, however it does come without some safety and logistical concerns. The contents of a landfill that has been in operation for many years may be questionable. Presence of hazardous wastes can result in health and disposal problems. The best way to deal with the possibility of finding hazardous waste is to establish personal protective procedures and hazardous waste handling, testing and disposal mechanisms. It is a good idea to take borings from the fill to get a cursory idea of its composition before committing to a mining operation. Another concern is the public sentiment regarding 'digging up a dump'. Although an obstacle, public opposition can be mitigated through education and open communication. A community must ultimately consider the advantages and disadvantages, both socioeconomic and environmental, to make the best decision.

### Promising Developments (5)

Research, such as that conducted at the University of Florida, is showing the viability of operating the landfill as an indefinite bio-reactor. The research is based on accelerated waste stabilization through leachate recirculation, followed by mining and re-use of landfill cells. Estimates predict that over a fifty year life, the combined effects of bio-decomposition, cover soils recovery and re-use, recovery and recycling of mined wastes, and only permanent entombment of the stabilized residuals will reduce the landfill acreage required from 203 acres to 65 acres. Such developments promise extended life of landfill sites and stabilized cells upon closure. The stabilized cells will be better suited for ultimate development.

## CHAPTER 10 CONCLUSION

Municipal solid waste landfills have emerged from being widely classified as 'dumps' and liabilities to community assets that serve as an essential component of integrated solid waste management. The role of the landfill as an asset can successfully continue long after closure. Solid waste managers, community leaders and local citizens must be informed about the potentials and pitfalls of a landfill site that has closed, or is approaching closure. There are many possibilities for re-use that will benefit a community or region functionally, aesthetically, and financially. Appendix [D] presents several proposed end-use plans.

These options need to be tailored to the needs of the community and the unique characteristics of a particular landfill. The issues presented and discussed in this guide must be carefully considered and accounted for when planning development on a closed landfill site. Avoidance or haste can be a costly error. The degree of risk that is involved with each issue is largely dependant on the landfill's age. The age will be indicative of established environmental controls and operational procedures. The established controls and procedures can provide a reliable baseline for additional risk mitigation that will be required prior to implementation of a re-use plan. Landfill mining offers an excellent opportunity to correct historic deficiencies within a landfill, stabilize a section of the site, or even delay the closure.

A community must do the best they can with an old landfill, however planning for the end-use of a future landfill must begin at conception. Foresight can influence the design, construction and operation of the landfill to best suit post-closure visions. The placement of utilities, environmental control networks, support facilities, and waste can be modified to

better accommodate planned development. Continued advancements in accelerated waste biodegradation complemented by a proactive reutilization strategy will undoubtedly promote modern landfills as an indefinite asset to society.

**APPENDIX A**  
**CLOSURE PLAN FOR ALACHUA COUNTY, FL. SOUTHWEST LANDFILL**

**Closure**

Certain activities must be performed during closure of the Southwest Landfill so that it will not significantly threaten human health or the environment. Much of the information required in this subsection appears elsewhere in this permit application. Therefore, this subsection references the appropriate subsections of this application as applicable.

The operational conditions of the closure plan are expected to achieve the following results:

- Decrease the long-term potential for release of contaminants from the landfill to the environment
- Decrease future operation and maintenance costs associated with the leachate collection, handling, and treatment system
- Address the closure of the waste tire storage and processing area and the asbestos disposal area

**Closure Schedule**

At least 1 year before the projected date when wastes will no longer be accepted, Alachua County will submit to FDER's Northeast District Office a schedule for cessation of waste acceptance and closure of the landfill. At least 120 days before closure, the County will also provide notice of closure to users of the landfill by posting and maintaining signs at the landfill entrance. These signs will give the date of closure, the location of alternative disposal facilities, and the name of the person responsible for closing the landfill. Within 10 days before closure, the County will publish a notice of the closure in the legal advertising section of a newspaper of

general circulation in Alachua County. Proof of such notification will be provided to FDER within 7 days after publication.

At least 90 days before closure, Alachua County will notify FDER and, if necessary, submit a revised closure plan to FDER that is in compliance with FAC Rule 17-701.073.

## **Closure Plan**

### ***General Information***

**Identification.** The Alachua County Southwest Landfill is located in the southwest corner of Alachua County, Florida, approximately 2 miles southwest of the town of Archer, Florida, on SR 24. The landfill contains Class I and Class III disposal facilities.

**Person to Contact.** The primary person to contact regarding the landfill is Mr. John Carter, Assistant Director of Public Works for Waste Management, P.O. Box 1188, Gainesville, Florida, 32602-1188 (phone, 904/495-9215), or his designated representative.

**Consultants.** This closure report has been prepared by CH2M HILL, Gainesville, Florida. The primary engineer of record is R.J. Bruner, III, P.E.

**Owner and Operator.** The landfill is owned by Alachua County, Florida, and operated under the jurisdiction of the Alachua County Public Works Department, Gainesville, Florida.

**Location.** The main entrance of the landfill is located in Section 19, Township 11 south, Range 18 east, at 29° 30' 45" latitude and 82° 32' 53" longitude.

**Total Area.** The landfill property covers a total area of 232.54 acres. A number of disposal areas at the site have received final cover, including the 30-acre unlined Class I disposal area, the 11-acre unlined Class I disposal area, and the 7-acre Class III disposal area. Active disposal areas at the site include a 12-1/2-acre, lined Class I disposal area (Section 1); another 15-acre, lined Class I disposal area (Section 2); and an 11-acre Class III disposal area. At the time of closure, 18 acres will have been devoted to the disposal of Class III waste and 68.5 acres to the disposal of Class I waste, and approximately 27.5 acres of the Class I disposal area will have a liner with a leachate collection and removal system.

**Legal Description.** The following legal description was prepared for the landfill property (Alachua County Department of Public Works, 1992):

86°22'15" West, a distance of 3,607.70 feet, to a set R/C no. 244; thence North 0°57'30" West 299.96 feet to the north line of said Section 30;

Thence South 86°22'15" East along the north line of said Section 30 and the south line of said Section 19, a distance of 300.00 feet, to the point of beginning. All lying and being in Alachua County, Florida.

Containing 232.54 acres, more or less.

**History.** A detailed history of the landfill is presented in sections 1 and 6 of this permit application.

**Waste Types.** The landfill has two active disposal areas to be permitted under this application: the Class I lined disposal area and the Class III disposal area. The Class I area will receive only Class I municipal solid waste and the Class III area will receive only Class III waste. A detailed description of the wastes disposed of in the landfill is presented in Section 3 of this document.

### ***Area Information***

Information for the area surrounding the landfill site (minimum 1-mile radius from the landfill property boundaries) is provided in Section 2 of this document. Discussions on the following topics can be found in Section 2:

- Topography
- Hydrology
- Geology
- Hydrogeology
- Ground and surface water quality
- Land use information

### ***Ground Water Monitoring Plan***

The proposed ground water monitoring plan is discussed in detail in this section.

### ***Gas Migration Investigation***

The gas migration investigation is discussed in this section under the heading, Gas and Odor Control.

### ***Effectiveness of Existing Landfill Design and Operation***

A report assessing the effectiveness of the landfill design and operation will be prepared by Alachua County and submitted as part of the closure permit application. This report, which will be based on the area information report, the ground water

monitoring plan, and the gas migration report, will discuss the effects of the landfill on adjacent ground and surface waters and the landfill area. The following concerns will also be addressed in the closure permit application:

- Effectiveness and results of the ground water investigation
- Effects of surface water runoff, drainage patterns, and existing storm water controls
- Extent and effects of methane gas migration, Lower Explosive Limit (LEL) percentage readings in migration paths, and description of the gas venting system
- Condition of the existing cover, thickness, and types of soils or materials used for cover, and effectiveness of cover material as a leachate control mechanism
- Nature and characteristics of the wastes disposed of at the landfill

### *Closure Design Plan*

When the lined Class I disposal area has reached capacity, the landfill will enter the final closure period. The Class I disposal area, Class III disposal area, tire processing and storage area, and asbestos disposal area will simultaneously undergo final closure to make the transition to the new solid waste management facility. As described in this section, a number of areas have already received final cover, however, a request for permitted closure will not be made until the lined Class I area is filled to capacity. This will eliminate the need for two separate closure permit applications.

Upon closure of the landfill facility, public access to the waste tire processing and storage area will be stopped and no waste tires will be accepted. A notice will be posted at the facility gates indicating the site is closed and identifying the location of the nearest waste tire facility. All remaining waste tires stored onsite will be processed (either chipped or cut), and all processed tires and residuals will be disposed of in the Class III disposal area before final closure. FDER will be notified upon closure of the waste tire processing and storage area.

**Topography.** The existing topography is depicted in Figure 5-14.

**Final Cover Installation Plans.** Plans describing the installation of the final cover are presented in this section under the heading, Cover. Long-term maintenance of the cover is discussed in this section under the heading, Post-Closure and Maintenance.

**Leachate Control.** Leachate control for the Class III waste cell is affected by the relatively impervious final cover and by routing storm water off of the cover to

surface water retention basins on the landfill property. The Class I lined disposal area uses these surface features and includes a liner with a leachate collection and treatment system. The existing leachate recirculation ponds will be filled and the leachate will be treated by either recirculation through direct injection into the closed, Class I, lined, disposal area or pretreatment at the onsite treatment plant. Leachate handling is discussed in greater detail in this section under the headings Leachate Collection System and Leachate Treatment and Handling. A schematic diagram of the leachate treatment system is provided in Figure 5-9.

**Ground Water Protection.** As described in this section, prevention of ground water contamination is being accomplished by a number of methods. Cover selection and control of runoff limit the quantities of leachate-producing water entering the closed cell. Additionally, the Class I lined cell has a liner and a leachate collection system to prevent leachate from seeping through the bottom of the Class I disposal area and subsequently contaminating the ground water. Finally, the ground water monitoring system described in this section will check that these protective methods are functioning properly.

**Gas and Odor Control.** As discussed in this section under the heading, Gas and Odor Control, gas and odors will be monitored and controlled.

**Storm Water Control.** Storm water will be routed off of the covers through a series of drainage ditches to seven percolation ponds located on the property. Drainage facilities and percolation ponds are designed for the 100-year storm of critical duration.

**Access Control.** The landfill property is surrounded by a chain link fence, with access limited by a gate at the property entrance. After closure of the landfill, the gate will be locked to prevent unauthorized persons from entering the site. The property will be inspected periodically by a County employee to assure that no unauthorized use or destruction is occurring. Restricted access will remain in effect until the landfill has stabilized and there is no evidence that the property is being used as an unauthorized dump site.

**Final Use.** Final use of the property is discussed under the heading, Final Use, in this section.

### ***Closure Operation Plan***

Closure operations will begin at the end of the active life of the Class I disposal area. Final cover will be applied to all disposal areas at the facility within 180 days of the final application of waste to the lined Class I area. Final cover for all disposal areas (Class I, Class III, and asbestos) is discussed in detail in this section under the heading, Cover. Cover installation includes seeding and maintaining grass.

Gas and odor control features consist of active gas collection for the Class I areas and passive gas venting for the Class III areas, with installation as described in this section under the heading, Gas and Odor Control.

Drainage features consist of lined and unlined ditches constructed at the tops of the berms surrounding the Class I lined and Class III disposal areas and leading to the appropriate percolation ponds on the landfill property. Design of the drainage features is discussed in this section under the heading, Storm Water. After the lined Class I disposal area has received the final application of waste, final cover will be applied to that area and to the remaining disposal areas at the facility. The landfill will be closed to any further waste disposal. The landfill property will be maintained as grassland for a period of 20 years from the official closing date (see Closure Procedures below). During this 20-year period, all relevant aspects of the closure design plan will be maintained, including leachate control, ground water protection, gas and odor control, storm water control, access control, and final use.

### **Closure Procedures**

Upon approval of the closure plan and the issuance of a closure permit by FDER, the County will close the landfill in accordance with the approved plans and any special permit provisions.

**Survey Monuments.** The County will install concrete monuments to mark the boundaries of the landfill property and other permanent markers to outline the waste-filled areas. These latter markers will be tied to one or more of the boundary markers by a survey performed by an engineer or registered land surveyor. The location and elevation of all markers will be shown on the site plan filed with the "Declaration to the Public" described below. .

**Final Survey.** The County will have a final survey performed by an engineer or registered land surveyor to verify that final contours and elevations of the facility are in accordance with the plans approved of in the permit. Contours will be shown at no greater than 5-foot intervals. The County will include this information in an as-built report, which will be submitted to FDER in accordance with the closing schedule. .

**Declaration to the Public.** After closure operations are inspected and approved by FDER, the County will file a declaration to the public in the deed records in the Alachua County Clerk's office. The declaration will include a legal description of the property and a site plan specifying the area filled with solid waste, with reference to the monuments referred to earlier in this section. The declaration will also include a notice that any future owner or user of the site should consult with FDER prior to planning or initiating an activity that would disturb the landfill cover, monitoring system, or other control structures. A certified copy of the declaration will be filed with FDER.

**Official Closing Date.** Upon receipt of the documents required under the heading above, Declaration to the Public, FDER will acknowledge by letter to the County within 30 days that notice of termination of operations and closing of the facility has been received. The date of this letter will be the official date of landfill closing for the purposes of determining the long-term care period.

**Use of Closed Areas and Construction on Closed Landfill.** Closed landfill areas, if disturbed, are a potential hazard to public health, the ground water, and the environment. FDER will be consulted prior to conducting any activities at the closed landfill site. Complete information regarding activities after closure of the landfill is presented in this section under the headings, Final Use, Storm Water, Ground Water Monitoring Plan, and Post-Closure Inspection and Maintenance.

### **Post-Closure Inspection and Maintenance**

Post-closure inspection and maintenance involves the long-term care of the landfill so that it will not threaten human health or safety or the environment. Because abuse or misuse of the landfill property or decay or damage of the various design features could affect human health or safety or the environment, it is essential that the landfill and its design features be inspected periodically during post-closure.

#### **Responsibility**

The Alachua County Department of Public Works will be responsible for making sure that the landfill, once finally closed, will not pose a threat to human health or safety or the environment. This responsibility will last for a minimum 20-year period following the official closing date of the landfill. Post-closure care will consist of a regularly scheduled program to maintain dikes, cover, vegetation, erosion control, drainage systems, leachate collection/treatment systems, spray fields, ground water monitoring systems, and site security.

Alachua County will maintain a record of each inspection of the closed facility during the post-closure maintenance period. These records will indicate the person who performed the inspection and the date the inspection was made. The records also will indicate whether deficiencies or significant changes were observed and will describe the corrective action taken. These records, which will be archived by Alachua County for a period of 20 years after final site closure, will be available for review upon request by representatives of FDER.

During the post-closure period, Mr. John Carter, Assistant Director of Public Works for Waste Management, should be contacted, if necessary, at P.O. Box 1188, Gainesville, Florida 32602-1188 (phone, 904/495-9215), or his designated representative or successor should be contacted. Mr. Carter is responsible for seeing that the post-closure maintenance plan is carried out. If a different person is assigned this

responsibility, his or her name and address will be incorporated into the post-closure maintenance plan.

### *Inspections*

The following items will be inspected and maintained during the post-closure and maintenance period:

- Fencing and security
- Vegetation
- Cover
- Berms
- Drainage system
- Leachate collection, handling, and treatment system
- Gas vents
- Monitor wells

A sample post-closure inspection sheet, which may be used as a guide for these inspections, is presented in Figure 5-15.

**Fencing and Security.** The security fence and gates must be secure to prevent unauthorized entry into the landfill. Damage to the security fence and gates will be noted on the inspection sheet and repaired as soon as practical. Also, landfill grounds will be inspected for signs of unauthorized use. Signs of such activity will be duly noted on the inspection sheet and brought to the attention of the person responsible for the post-closure and maintenance plan so that corrective measures can be taken.

**Vegetation.** Vegetative cover will be inspected for its viability. Watering, fertilizing, and pesticide application will be performed, as necessary, to maintain the grass crops that cover the disposal areas. These crops will also be weeded, as necessary, to eliminate vegetation that might destroy the grass crop or the cover, such as deep root systems, which could penetrate and damage the moisture barrier layer of the cover. Similarly, trees should not be allowed to establish themselves on or near the berms surrounding the Class I lined cell as their roots may damage elements of the liner or leachate collection system.

**Cover.** Covers will be inspected for signs of storm water ponding or damage that may be caused by burrowing animals, erosion, or settlement. The nature and suspected cause of such damage will be noted on the inspection sheet and brought to the attention of the person responsible for the post-closure and maintenance plan so that remedial action can be taken as soon as practical. Repairs will be undertaken in a manner that maintains the integrity of the moisture barrier (clay) and drainage (sand) layers of the cover.

## Post-Closure Inspection Sheet

Item	Condition
<b>Security Fencing and Gates</b>	
Breaks in Fence	_____
<b>Vegetation</b>	
Established Growth	_____
<b>Cover</b>	
Erosion	
Uneven Subsidence	
Ponding of Water	_____
Surface Cracking	_____
<b>Gas Vents</b>	
Obstructions	
Breakage	
Unusual Odor	
<b>Berms</b>	
Erosion	_____
Uneven Subsidence	_____
<b>Drainage System</b>	
Obstruction	_____
Overtopping	_____
Proper Slope	_____
Erosion	_____
<b>Leachate Collection and Treatment System</b>	
Visible Damage	_____
Effluent	_____
Odor	_____
Effluent Sample Analysis (Attach Results)	_____
<b>Monitor Wells</b>	
Integrity	_____
Sampling	_____
Analysis (Attach Results)	_____
Ground Water Elevation (msl)	_____

**Comments:** (Attach Sheet)

Name	Signature	Date
------	-----------	------

**Berms.** Berms will be inspected for signs of sloughing or erosion, which will be noted on the inspection sheet and repaired as soon as practical. Repairs will include restoring earth or vegetation lost as a result of the damage.

**Drainage System.** Drainage trenches will be maintained free of debris that might block or inhibit drainage. Damage to the trenches or their liners, which may be caused by settlement, erosion, or misuse, will be noted on the inspection sheet and repaired as soon as practical.

**Leachate Collection, Handling, and Treatment System.** The leachate collection, handling, and treatment system will be maintained in good working order. Analyses of raw samples and samples taken from the treatment system's effluent will indicate the effectiveness of both the recirculation system and the treatment system. Measurements of effluent flow rates can indicate the integrity of the leachate collection system and the integrity of the Class I lined disposal area's cover. Visible damage, abnormal flow rates, unusual odors, and similar characteristics will be noted on the inspection sheet.

**Gas Vents.** At the time of cover inspection, the gas venting system will be inspected to be certain it is free of obstructions and that it is functioning properly. Damage or excessive odors will be noted on the inspection sheet.

**Monitor Wells.** Monitor wells will be inspected and sampled according to the schedule outlined under the heading, Ground Water Monitoring Plan, in this section. If any of the wells have been destroyed or fail to operate, it will be noted on the inspection sheet and the person responsible for the post-closure inspection and maintenance plan will be notified. The Alachua County Department of Public Works will then notify FDER, in writing, of the damage. Alachua County will replace inoperable wells within 60 days of the inspection that discovered the damage unless notified otherwise, in writing, by FDER.

**APPENDIX B**  
**COST ESTIMATE FOR FINAL COVER AT**  
**ALACHUA COUNTY, FL. SOUTHWEST LANDFILL**

**ESTIMATE SUMMARY**

PROJECT: ALACHUA COUNTY SOUTHWEST LANDFILL  
 FACILITY: FUTURE CLASS 1 COVER SYSTEM - 6 INCH CLAY COVER

DESCRIPTION	QTY	U N T	INSTALLED COSTS		CONTINGENCY 25.00%	MOB/BOND/INS 6.00%	OH & P 20.00%	TOTAL
			UNITS	AMOUNT				
<b>MECHANICAL</b>								
<b>STORMWATER POND P3</b>								
-15" CMP	60	LF	\$15 00	\$900	\$225	\$68	\$239	\$1,431
-30" CMP	200	LF	\$25 00	\$5,000	\$1,250	\$375	\$1,325	\$7,950
-42" CMP	100	LF	\$40 00	\$4,000	\$1,000	\$300	\$1,060	\$6,360
-STORMWATER DITCH	1400	CY	\$300 00	\$420,000	\$105,000	\$31,500	\$111,300	\$667,800
<b>FINISHES</b>								
<b>STORMWATER POND P3</b>								
-SEEDING	6000	SY	\$0 15	\$900	\$225	\$68	\$239	\$1,431
-FERTILIZER	6000	SY	\$0 03	\$180	\$45	\$14	\$48	\$286
-MULCHING	6000	SY	\$0 15	\$900	\$225	\$68	\$239	\$1,431
-SURFACE PREP	6000	SY	\$0 06	\$360	\$90	\$27	\$95	\$572
<b>STORMWATER POND P6</b>								
-SEEDING	6500	SY	\$0 15	\$975	\$244	\$73	\$258	\$1,550
-FERTILIZER	6500	SY	\$0 03	\$195	\$49	\$15	\$52	\$310
-MULCHING	6500	SY	\$0 15	\$975	\$244	\$73	\$258	\$1,550
-SURFACE PREP	6500	SY	\$0 06	\$390	\$98	\$29	\$103	\$620
<b>COVER</b>								
-SODDING	14800	SY	\$3 00	\$44,400	\$11,100	\$3,330	\$11,766	\$70,596
-SEEDING	136900	SY	\$0 15	\$20,535	\$5,134	\$1,540	\$5,442	\$32,651
-FERTILIZER	151700	SY	\$0 03	\$4,551	\$1,138	\$341	\$1,206	\$7,236
-MULCHING	136900	SY	\$0 15	\$20,535	\$5,134	\$1,540	\$5,442	\$32,651
-SURFACE PREP	151700	SY	\$0 06	\$9,102	\$2,276	\$683	\$2,412	\$14,472
<b>GAS SYSTEM</b>								
<b>HDPE PIPE</b>								
-18" PIPE	2700	LF	\$45.54	\$122,958	\$30,740	\$9,222	\$32,584	\$195,503
-12" PIPE	1210	LF	\$24.42	\$29,548	\$7,387	\$2,216	\$7,830	\$46,982
-4" PIPE	2500	LF	\$4.15	\$10,375	\$2,594	\$778	\$2,749	\$16,496
-18" X 4" CROSS	5	EA	\$900.00	\$4,500	\$1,125	\$338	\$1,193	\$7,155
-18" X 18" X 12" TEE	2	EA	\$637.00	\$1,274	\$319	\$96	\$338	\$2,026
-12" X 4" CROSS	5	EA	\$297.00	\$1,485	\$371	\$111	\$394	\$2,361
-2" PVC BALL VALVE	40	EA	\$50.00	\$2,000	\$500	\$150	\$530	\$3,180
-18" PVC BFV	4	EA	\$4,245.00	\$16,980	\$4,245	\$1,274	\$4,500	\$26,998
-12" PVC BFV	2	EA	\$834.00	\$1,668	\$417	\$125	\$442	\$2,652
<b>TOTAL</b>								<b>\$3,109,000</b>

APPENDIX C  
LANDFILL CLOSURE DESIGN AND CONSTRUCTION CHECKLIST

<b>LANDFILL CLOSURE DESIGN &amp; CONSTRUCTION CHECKLIST</b>	
<p><b>P R E - D E S I G N</b></p> <ul style="list-style-type: none"> <li><input type="checkbox"/> Benchmarks and ground topography have been independently verified.</li> <li><input type="checkbox"/> Horizontal limits of waste have been verified, staked in the field, and surveyed.</li> <li><input type="checkbox"/> Vertical limits of waste have been confirmed through historical research and investigation.</li> <li><input type="checkbox"/> All potential sources of liquid generation have been identified and quantified.</li> <li><input type="checkbox"/> The general closure performance objectives have been presented to the regulators in a face-to-face meeting.</li> </ul> <p><b>D E S I G N</b></p> <ul style="list-style-type: none"> <li><input type="checkbox"/> Performance standards (e.g., minimum/maximum grades), rather than exact grades or specifications, have been used liberally.</li> <li><input type="checkbox"/> All potential confined-space entry situations have been eliminated.</li> <li><input type="checkbox"/> Provisions have been made to handle gas in leachate collection system.</li> <li><input type="checkbox"/> Careful consideration has been given to exclude surface water and storm-saturated ground from the leachate collection system.</li> <li><input type="checkbox"/> Rugged, proven systems and materials have been specified (keep it simple).</li> <li><input type="checkbox"/> At 50% design stage, an on-site meeting and walk-through between owner, engineer, and independent, experienced contractor has been held.</li> <li><input type="checkbox"/> Details (e.g., trench widths, gabion sizes, etc.) have been built with standard construction equipment and material sizes.</li> <li><input type="checkbox"/> If possible, design has not included moving waste.</li> </ul>	<p><b>C O N S T R U C T I O N D R A W I N G S &amp; B I D P A C K A G E</b></p> <ul style="list-style-type: none"> <li><input type="checkbox"/> Pay quantities use area, length, or lump sum measurements (minimizing need for volume measurements).</li> <li><input type="checkbox"/> A general, flexible, pre-approved approach has been developed to handle leachate seeps.</li> <li><input type="checkbox"/> Details in construction drawings have been drawn to scale.</li> <li><input type="checkbox"/> An independent, thorough, constructibility review by a paid, independent, experienced contractor has been made on drawings, specifications, and bid items.</li> <li><input type="checkbox"/> Drawings state that contractor is responsible for safety (e.g., trenches, hazardous atmosphere) and is to submit detailed safety programs.</li> </ul> <p><b>C O N S T R U C T I O N</b></p> <ul style="list-style-type: none"> <li><input type="checkbox"/> An experienced construction manager has been provided on site.</li> <li><input type="checkbox"/> Design engineer has been retained to approve value engineering and equivalent-performance changes.</li> <li><input type="checkbox"/> Engineer has provided personnel continuity from initial pre-design investigation to final closure.</li> <li><input type="checkbox"/> Levels of communication and accountability are completely established and thoroughly understood.</li> <li><input type="checkbox"/> An experienced quality assurance/quality control monitor has been retained and will report deficiencies directly to the construction manager.</li> </ul>

**APPENDIX D  
MISCELLANEOUS END-USE PLANS**

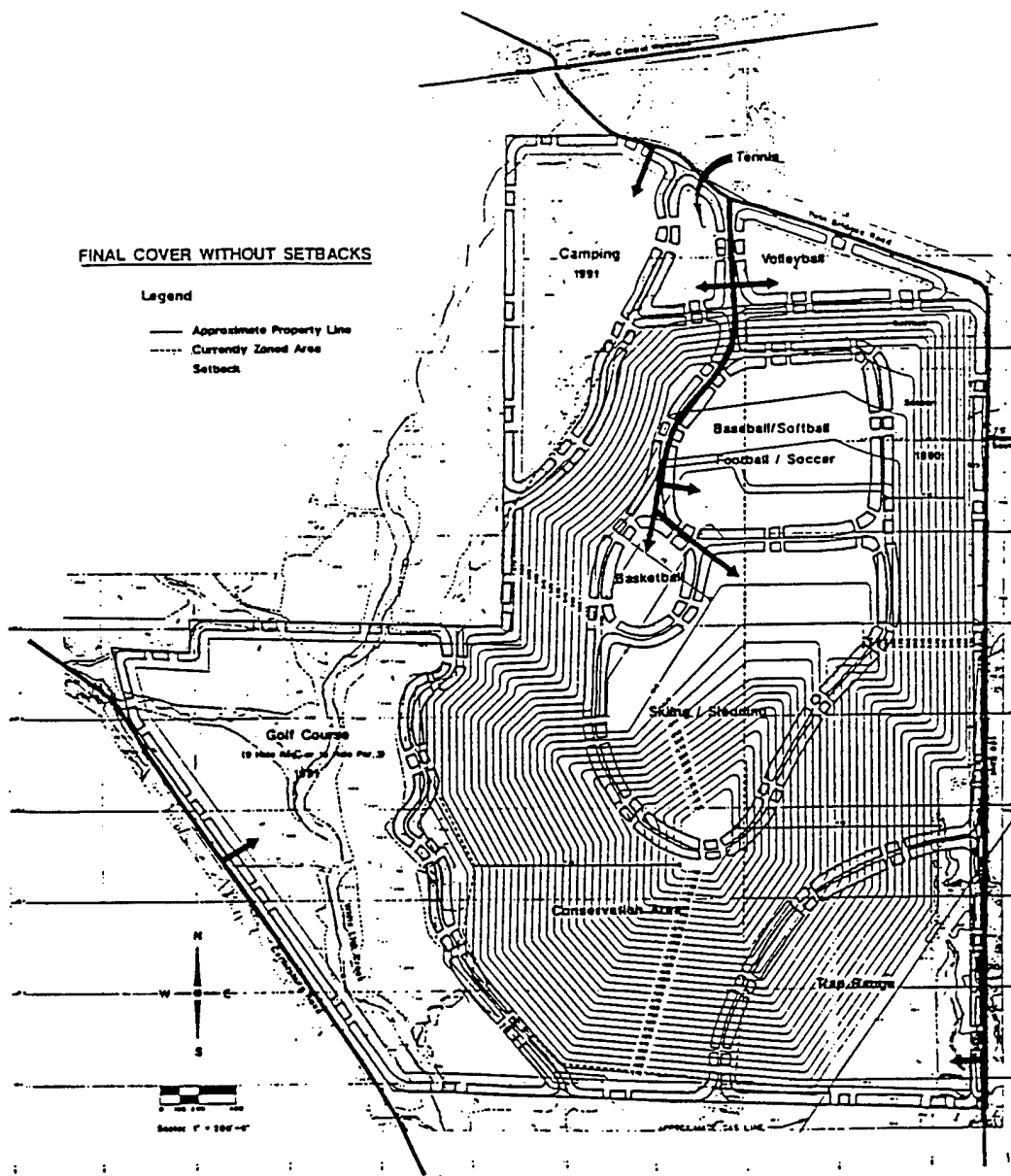

**Recreation Schematic**

DANVILLE SANITARY LANDFILL

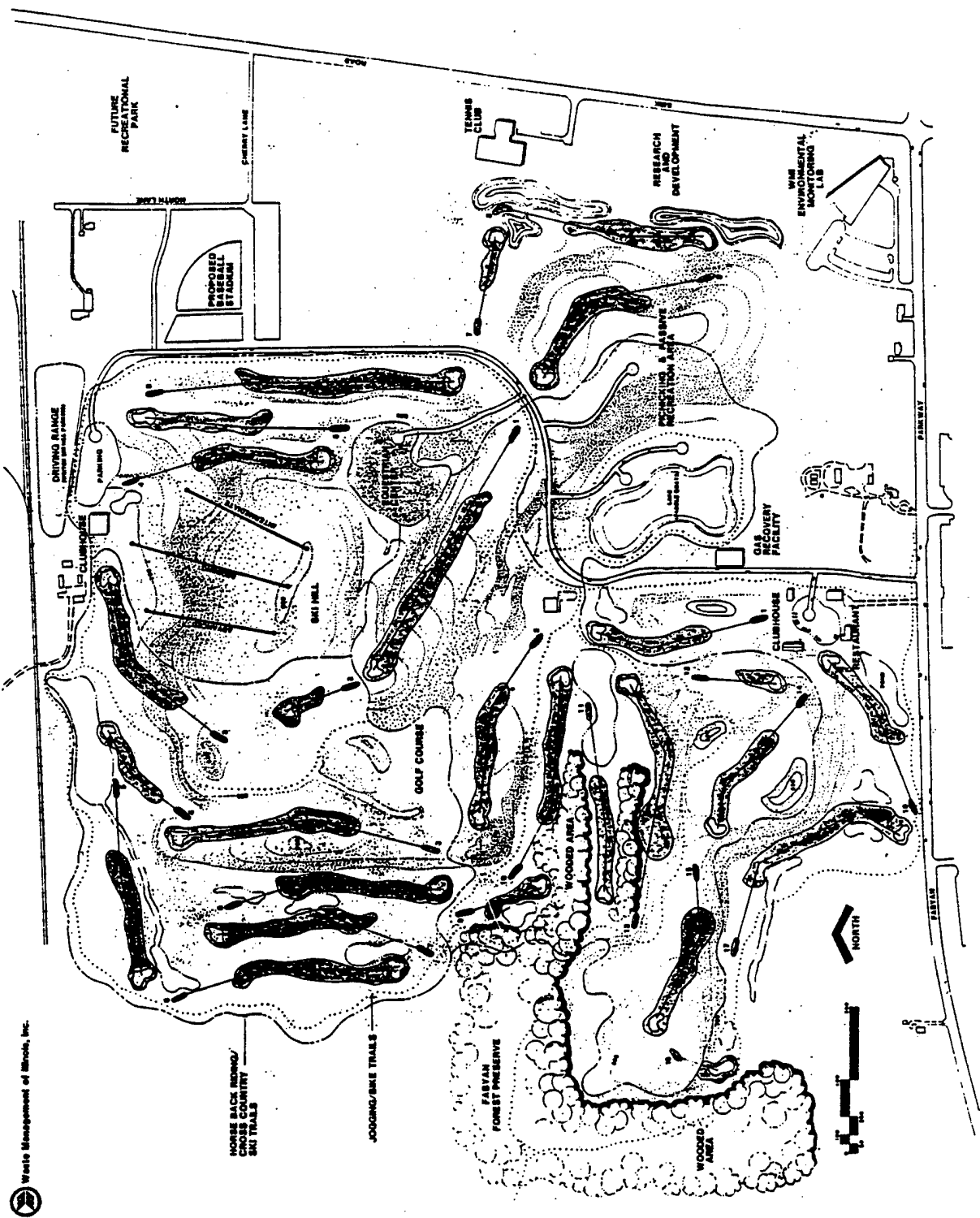

Watts Management of Illinois, Inc.

SETTLER'S HILL RECREATIONAL END USE PLAN

## FINAL END USE PLAN



These are very few recreational activities in rural Sandusky County. One of the proposed uses of the Tri-City RDF is a winter recreational area.

The final permitted grades of the landfill are 60 feet above ground surface; not quite enough for a ski hill, but perfect for a toboggan run. It has been suggested that our clay borrow area across the street would make a nice ice-skating rink when soil borrow activities are complete. In the summer, the pond could be stocked with fish.

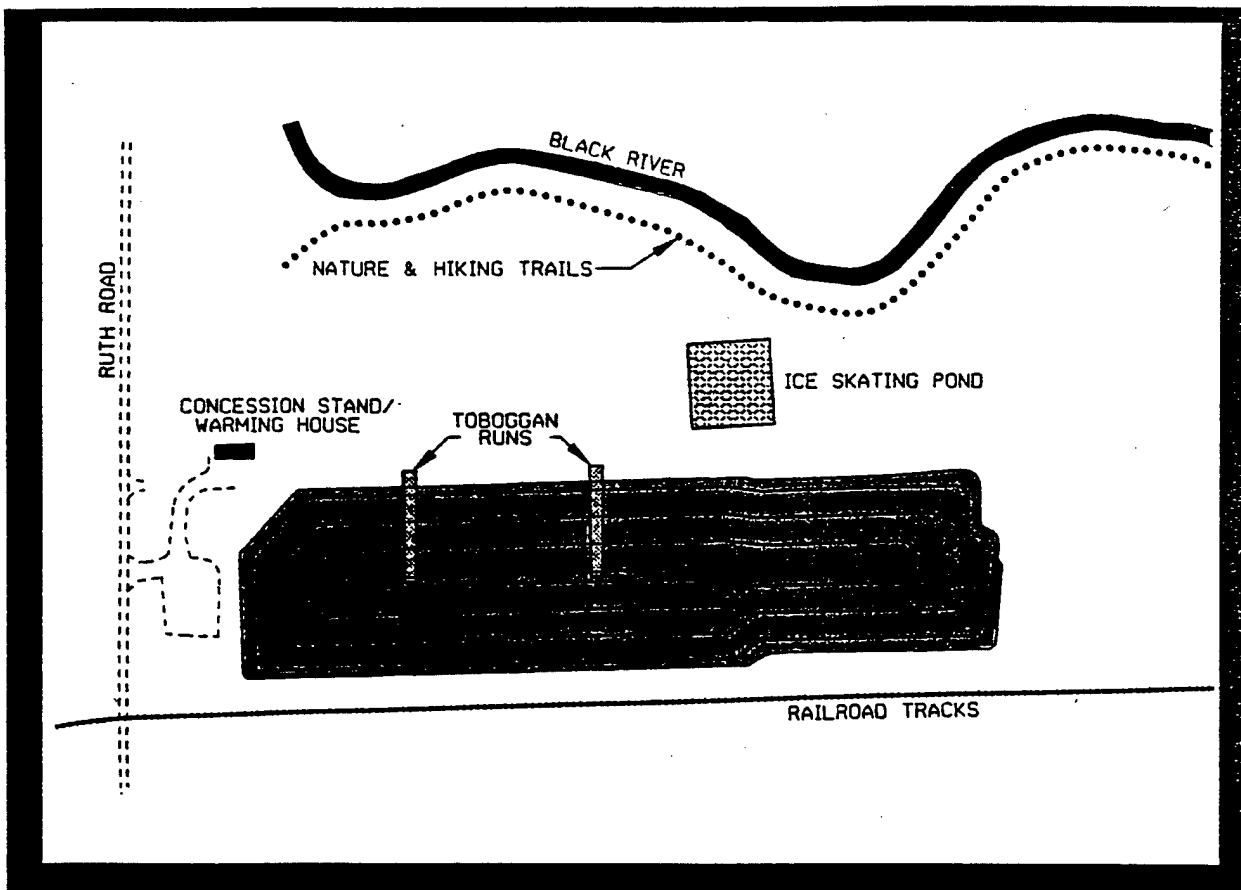



## Final End Use Plan

Lake Orion Township and the surrounding areas are rapidly developing and expanding their suburban and industrial bases. More and more woodland and farm land are being converted into subdivisions, strip malls, and industrial parks.

The loss of greenspace in this community will be offset by the eventual closure of the Eagle Valley Recycling and Disposal Facility. The 245 acres of buffer area and vegetated completed landfill will be opened to the community as a recreation/nature area. Existing wetlands will be enhanced and expanded to create more areas for wildlife.

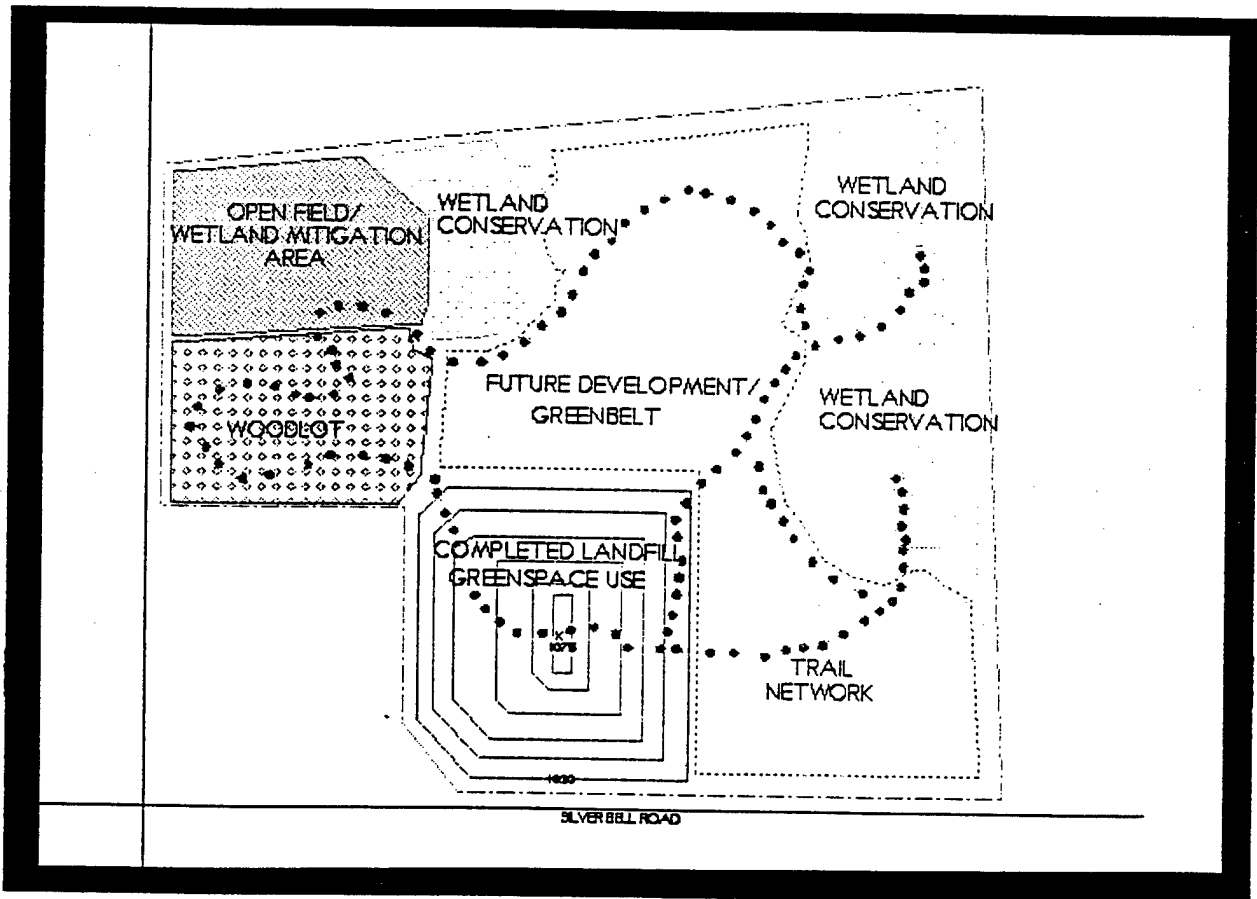

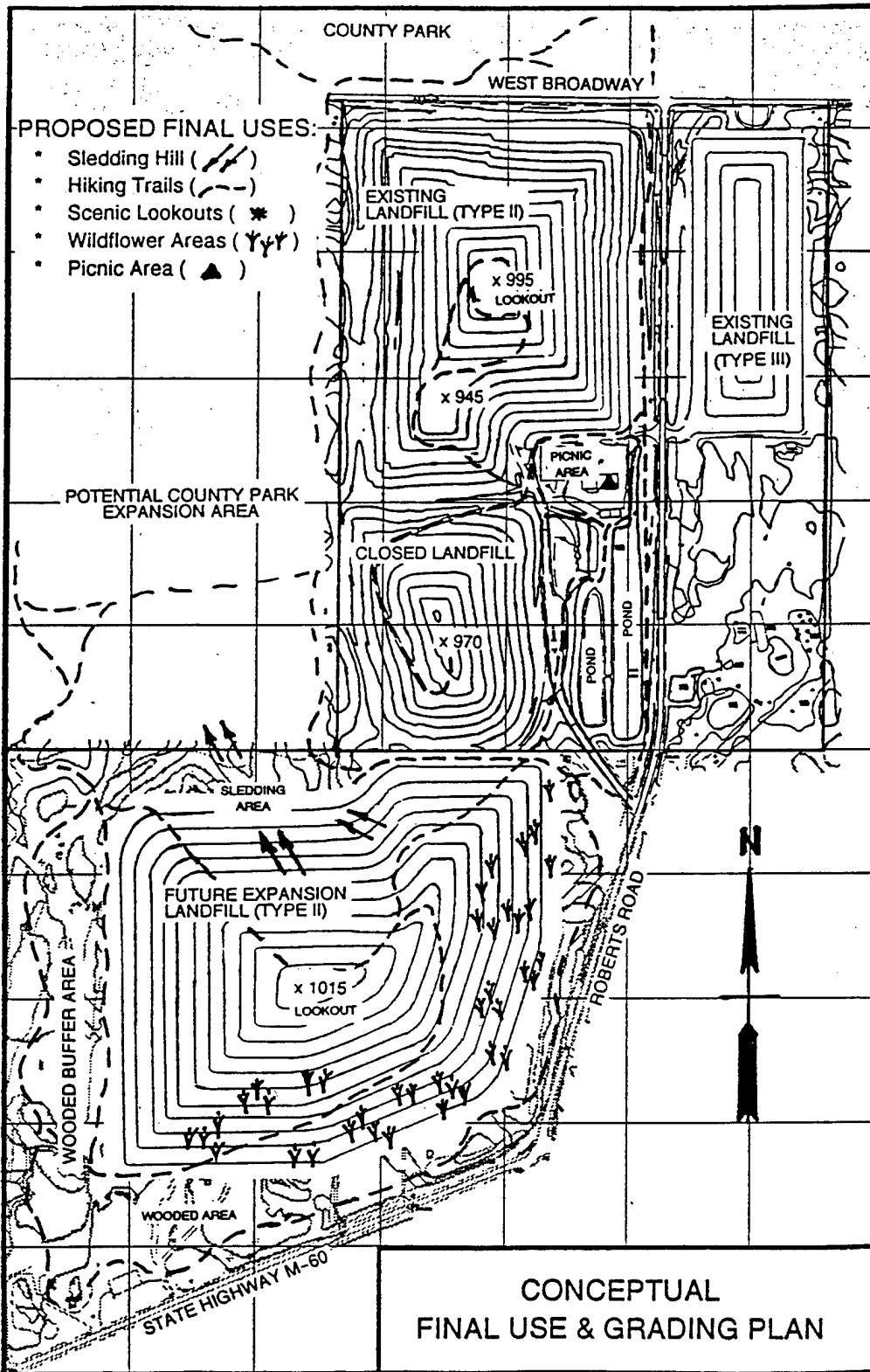

**PROPOSED FINAL USES:**

- Sledding Hill ( / )
- Hiking Trails ( - - - )
- Scenic Lookouts ( \* )
- Wildflower Areas ( Y Y )
- Picnic Area ( ▲ )

**CONCEPTUAL  
FINAL USE & GRADING PLAN**

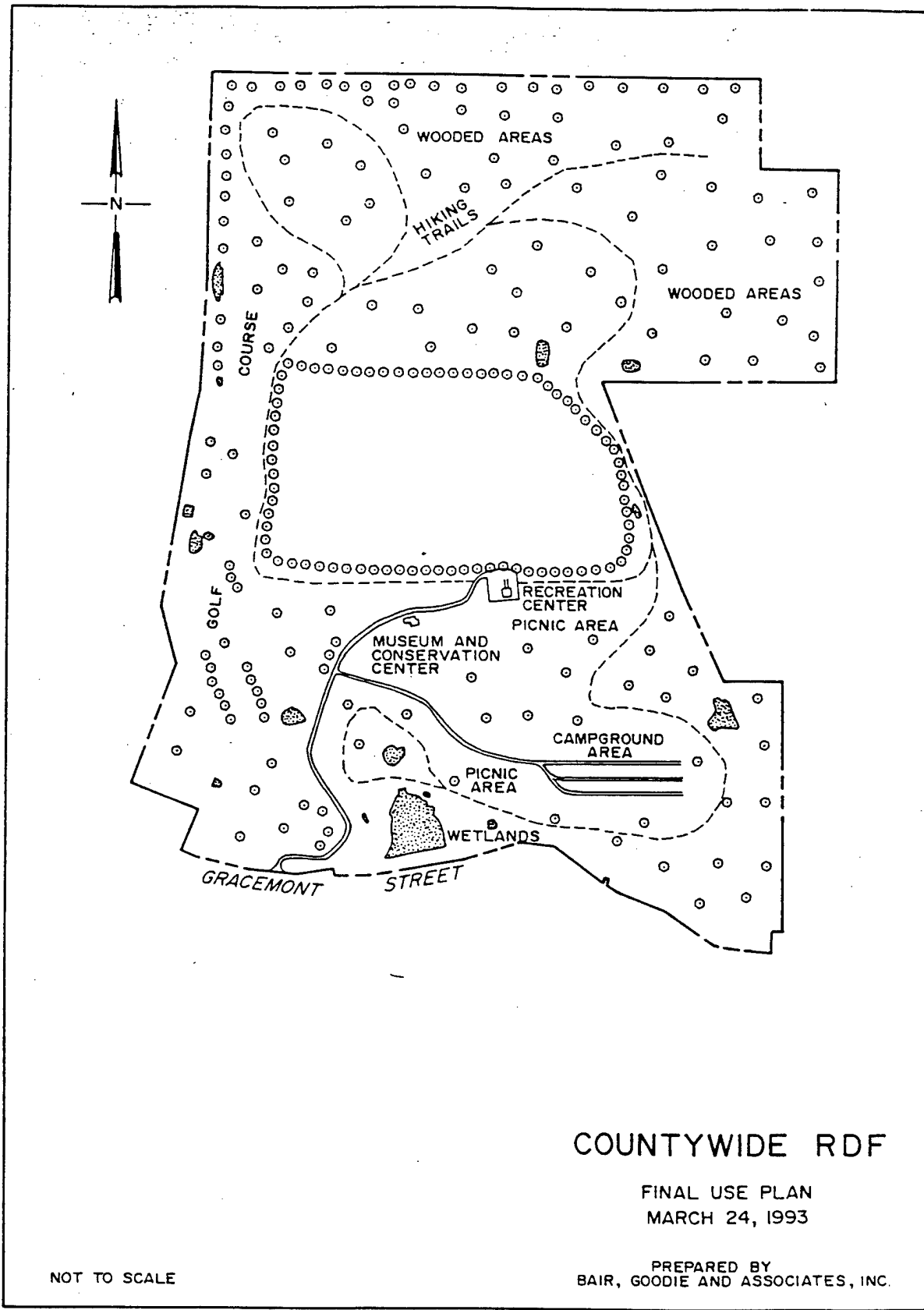

COUNTYWIDE RDF

FINAL USE PLAN  
MARCH 24, 1993

PREPARED BY  
BAIR, GOODIE AND ASSOCIATES, INC.

NOT TO SCALE

## REFERENCES

1. Tchobanoglous, G., H. Theisen., and S. Vigil, Integrated Solid Waste Management: Engineering Principles and Management Issues, McGraw-Hill, Inc., New York, NY., 1993.
2. Schoppman, G., Solid Waste Engineering: An Economic Analysis of Post Closure Alternatives for the Alachua County Southwest Landfill, report prepared for Dr. C. Glagola, Department of Civil Engineering, University of Florida, Gainesville, FL., December 1995.
3. Oweis, I. S., and R. P. Khera, Geotechnology of Waste Management, Butterworth & Co. Ltd., London, 1990.
4. U. S. Environmental Protection Agency, Criterial for Municipal Solid Waste Landfills, Volume 40, Code of Federal Regulations, Part 258, Washington, D. C., 1995.
5. Alachua County, FL., Public Works Department, Office of Waste Management, A Proposal for a Basic Modern Landfill and a Modern Landfill with Mining at Site Echo, Gainesville, FL., May 2, 1996.
6. The State University System of Florida, Center for Solid and Hazardous Waste Management, Municipal Solid Waste Landfills: Problems and Issues, Conference Proceedings, Orlando, FL., July 25-26, 1990.
7. Florida Department of Environmental Protection, Waste Management, Solid Waste Section, Florida Solid Waste Trends, Tallahassee, FL., 1996.
8. Willis, D., "Landfill Management Faces a High-Tech Future," World Wastes, Vol. 37, No.5, Atlanta, GA., May 1994, pp. 22-30.
9. Kropf, S. J., The Financial Feasibility of a Landfill Treatment Facility, report submitted to the Department of Environmental Engineering Sciences, University of Florida, Gainesville, FL., December 10, 1993.
10. McBean, E. A., F. A. Rovers, and G. J. Farquhar, Solid Waste Landfill Engineering and Design, Prentice Hall, Inc., Englewood Cliffs, NJ., 1995.
11. Florida Department of Environmental Protection, Solid Waste Management Facilities, Florida Administrative Code, Chapter 62-701, Tallahassee, FL., 1994.

12. Bagchi, A., Design, Construction, and Monitoring of Landfills, John Wiley & Sons, Inc., New York, NY., 1994.
13. Beaudoin, M. R., A. Stockman, and D. Fletcher, "Landfill Closure - Sounds Easy, Doesn't It?," Waste Age, Vol. 26, No. 7, Washington, DC., July 1995, pp. 107-111.
14. CH2M Hill, "Detailed Evaluation of Integrated Solid Waste Management Systems," Technical Memorandum # 5, Gainesville, FL., July 1994.
15. CH2M Hill, Operating Permit for the Southwest Landfill, Alachua County, FL., Volume 1 - Report, Gainesville, FL., 1992.
16. Sebesta, F. W., "Notes Prepared for Construction Cost Estimating Presentation," 1994 Landfill Design Series, Vol. 6, Closure and Long-Term Care, University of Florida, Center for Training Research and Education for Environmental Occupations, Gainesville, FL., April 1994, Section I.
17. Boyd, G. M., "Landfill Reclamation: Helping to Develop Golf Courses on Old Landfills," Proceedings of the Conference on Landfill Golf Course Developments: Environmentally Beneficial Assets, The National Golf Foundation, City of Industry, CA., November 12-14, 1995, pp. 48-51.
18. Nealon, G., and D. L. Hansen, "A New Public Works Complex on an Old Landfill," Public Works, Vol. 22, Ridgewood, NJ., April 1991, pp. 46-47.
19. Gruper, J. S., G. Kepler and D. Clark, "Conversion of a Dump into an Environmental Community Center," Public Works, Vol. 124, Ridgewood, NJ., March 1993, pp. 52-55.
20. Brookshire, R., "Closed Landfill Prepares for Takeoff," World Wastes, Vol. 38, No. 12, Atlanta, GA., December 1995, pp. 19-21.
21. Hepler, H., "Treez In the 'Hood: A Look at City Parks," American City and County, Vol. 110, Pittsfield, MA., February 1995, pp. 20-32.
22. Hauser, R. Jr., "Landfill Reuse Rises as Space Becomes Scarce," World Wastes, Vol. 37, No. 2, Atlanta, GA., February 1994, p.10.
23. Paukstis, S., "Landfill Transformed into Recreation Area," American City and County, Vol. 108, Pittsfield, MA., June 1993, p.30.

24. Treadway, D., "Landfills Become Landscapes: The American Park Revolution," American City and County, Vol. 104, Pittsfield, MA., March 1989, pp. 48-55.
25. Jain, R. K., "Environmental Legislation and Regulations," Standard Handbook of Environmental Engineering, edited by R. A. Corbitt, McGraw Hill, Inc., New York, NY., 1990.
26. Golden, M. S., "Pros and Cons of Developing Recreational Facilities on Closed Landfills," Proceedings of the International Conference on Marinas, Parks and Recreation Developments, American Society of Civil Engineers, New York, NY., 1994, pp. 257-260.
27. Cooper, C. D., Landfill Gas Emissions: Final Report, State University System of Florida, Center for Solid and Hazardous Waste Management, Gainesville, FL., May 1990.
28. University of Florida, Center for Training Research and Education for Environmental Occupations, 1994 Landfill Design Series, Vol. 6, Closure and Long-Term Care, Gainesville, FL., 1992, Section D.
29. Card, G. B., "Development On and Adjacent to Landfill," Journal of the Institution of Water and Environmental Management, Vol. 6, No. 3, London, June 1992, pp. 362-371.
30. Parker, A., "Landfill gas - a potential environmental hazard," Disasters, Vol. 10, No. 1, Elmsford, NY., 1986, pp. 65-68.
31. U. S. Environmental Protection Agency, "Standards of Performance for New Stationary Sources and Guidelines for Control of Existing Sources: Municipal Solid Waste Landfills," Federal Register, Vol. 61, No. 49, Washington, DC., March 12, 1996, pp. 9905-9908.
32. Kraemer, T., "Landfill Gas Control," Waste Management and Industrial Process Tech Transfer Topics, edited by G. Peterson, CH2M Hill, Gainesville, FL., July 1989.
33. Haughey, R., "Golf Course Developments on Closed Landfills," Proceedings of the Conference on Landfill Golf Course Developments: Environmentally Beneficial Assets, The National Golf Foundation, City of Industry, CA., November 12-14, 1995 pp. 52-59.

34. Pernicano, C., Economic Analysis of Alternative Uses for Landfill Gas As a Fuel, non-thesis project presented to the Department of Environmental Engineering, University of Florida, Gainesville, FL., Fall 1993.
35. Bier, J. D., "Effects of Landfill Gas Management at the Industry Hills Recreation and Conference Center," Proceedings of the Conference on Landfill Golf Course Developments: Environmentally Beneficial Assets, The National Golf Foundation, City of Industry, CA., November 12-14, 1995, pp. 66-72.
36. McAdams, C. L., "Venice Park Landfill: Working with the Community," Waste Age, Vol. 24, Washington, DC., September 1993, pp. 38-44.
37. Dunn, R. J., "Design and Construction of Foundations Compatible with Solid Wastes," Landfill Closures...Environmental Protection and Land Recovery, Geotechnical Special Publication No. 53, edited by R. J. Dunn and U. P. Singh, American Society of Civil Engineers, New York, NY., 1995, pp. 139-159.
38. Gifford, G. P., A. O. Landva and V. C. Hoffman, "Geotechnical Considerations When Planning Construction on a Landfill," Geotechnics of Waste Fills - Theory and Practice, ASTM STP 1070, edited by A. Landva and G. D. Knowles, American Society for Testing and Materials, Philadelphia, PA., 1990, pp. 41-56.
39. Edil, T. B., V. J. Ranguette and W. W. Wuellner, "Settlement of Municipal Refuse," Geotechnics of Waste Fills - Theory and Practice, ASTM STP 1070, edited by A. Landva and G. D. Knowles, American Society for Testing and Materials, Philadelphia, PA., 1990, pp. 225-239.
40. Weiss, S., Sanitary Landfill Technology - Pollution Technology Review, Noyes Data Corp., New Jersey, 1974.
41. O'Leary, P. and P. Walsh, "Landfill Closure and Long-Term Care," Waste Age, Washington, DC., March 1992, pp. 87-94.
42. Keech, M. A., "Design of Civil Infrastructure Over Landfills," Landfill Closures...Environmental Protection and Land Recovery, Geotechnical Special Publication No. 53, edited by R. J. Dunn and U. P. Singh, American Society of Civil Engineers, New York, NY., 1995, pp. 160-183.

43. Landva, A. O., and J. I. Clark, "Geotechnics of Waste Fill," Geotechnics of Waste Fills - Theory and Practice, ASTM STP 1070, edited by A. Landva and G. D. Knowles, American Society for Testing and Materials, Philadelphia, PA., 1990, pp. 86-103.
44. Phillips, A. B., K. Wallace and K. F. Chan, "Foundations for reclaimed landfill sites," Geotechnical Management of Waste and Contamination, edited by Fell, Phillips and Gerrard, Australian Geomechanics Society, Balkema, 1993, pp. 185-208.
45. Arent, K. A., "The Creation of a Park," Public Works, Vol. 120, Ridgewood, NJ., May 1989, pp. 58-60.
46. Naber, T., "Today's Landfill Is Tomorrow's Playground," Waste Age, Washington, DC., September 1987, pp. 46-58.
47. Keech, M, "Construction of Retail Buildings on Closed Landfill Sites," Public Works, Vol. 127, No. 3, Ridgewood, NJ., March 1996, pp. 40-42.
48. National Center for Resource Recover, Inc., Sanitary Landfill -A State of the Art Study, Lexington Books, Lexington, MA., 1974.
49. Miller, F. H., Jr., M. Parkes, and G. Plotner, "Golf and the Environment," Urban Land, Vol. 54, No. 8, Washington, DC., August, 1995, pp. 59 (7).
50. Spain, K., "Get It Right At the Start...", Waste Age, Vol. 24, No. 2, Washington, DC., February, 1993, pp. 57-58.
51. Chevin, D., "Tip top tee time," Building, London, September 13, 1991, pp. 48-51.
52. American Society of Civil Engineers, "East Bay Waste Management: from Landfill to Park," Civil Engineering, ASCE, edited by K. A. Godfrey, Jr., Vol. 51, No. 6, New York, NY., June 1981, pp. 65-67.
53. Tosh, J. E., E. Senior, J. E. Smith and I. A. Watson-Craik, "Landfill Site Restoration: The Inimical Challenges of Ethylene and Methane," Environmental Pollution, Vol. 83, No. 3, England, 1993, pp. 335-340.
54. Hansen, J. M. and G. W. Druback, "Environmental Benefit Plan for Blydenburgh Landfill," Waste Age, Vol. 26, Washington, DC., April 1995, pp. 241-248.

55. Young, W., "A Dump No More," American Forests, Vol. 101, No. 9, Washington, DC., Autumn 1995, pp. 58 (3).
56. Gordon, S., "Tree Planting on Landfills," BioCycle, Vol. 32, Emmaus, PA., October 1991, p.80.
57. New Jersey Advisory Council on Solid Waste Management, End-Use of Landfills, A report from a conference and public hearing entitled: "Design Now For the Future: End-Use of Landfills," Trenton, NJ., April 1994.
58. Morelli, J., "Landfill Reuse Strategies," BioCycle, Vol. 31, No. 4, Emmaus, PA., April 1990, pp. 60-61.
59. Carlile, J., "Reclaiming Landfills," American City and County, Vol.107, Pittsfield, MA., July 1992, pp. 38 (3).
60. Spencer, R., "Landfill Space Reuse," BioCycle, Vol. 31, No.2, Emmaus, PA., February 1990, pp. 30-33.
61. Nelson, H., "Landfill Reclamation Projects on the Rise," BioCycle, Vol. 36, No. 3, Emmaus, PA., March 1995, pp. 83-84.
62. Nelson, H., "Landfill Reclamation Strategies," BioCycle, Vol. 35, No. 3, Emmaus, PA., October 1994, pp. 40-44.
63. Homsy, G., "There's Cash in That Trash," Planning, Vol. 61, No. 11, Chicago, IL., November 1995, pp. 16-17.
64. Collier County, FL. Solid Waste Department, Landfill Reclamation Technology Transfer Information, Naples, FL., 1991.
65. The Solid Waste Association of North America, miscellaneous end-use plans on file (after Waste Management, Inc.), Silver Springs, MD, 1996.