

NAVY EXPERIMENTAL DIVING UNIT

REPORT NO. 1-92

EVALUATION OF MAKO 5415
HIGH PRESSURE BREATHING AIR COMPRESSOR

GEORGE D. SULLIVAN
MARCH 1992

NAVY EXPERIMENTAL DIVING UNIT



19960904 029

DISTRIBUTION STATEMENT A
Approved for public release;
Distribution Unlimited

DTIC QUALITY INSPECTED 1

DISCLAIMER NOTICE

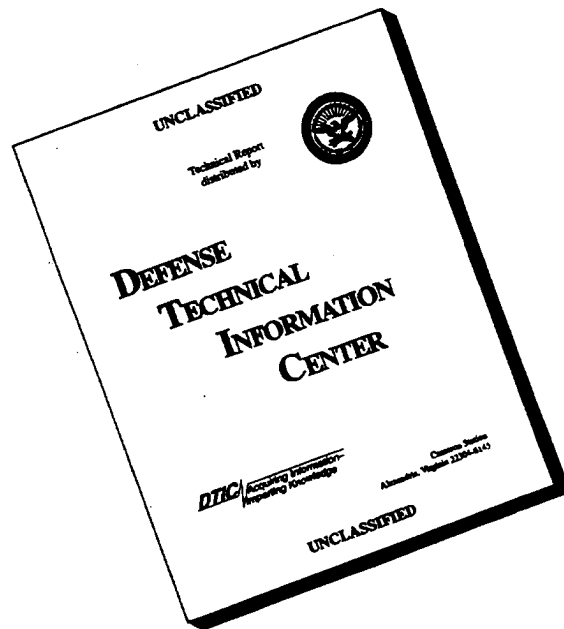

THIS DOCUMENT IS BEST QUALITY AVAILABLE. THE COPY FURNISHED TO DTIC CONTAINED A SIGNIFICANT NUMBER OF PAGES WHICH DO NOT REPRODUCE LEGIBLY.



DEPARTMENT OF THE NAVY
NAVY EXPERIMENTAL DIVING UNIT
PANAMA CITY, FLORIDA 32407-5001

IN REPLY REFER TO:

NAVSEA TASK 92-002 & 92-003

NAVY EXPERIMENTAL DIVING UNIT

REPORT NO. 1-92

EVALUATION OF MAKO 5415
HIGH PRESSURE BREATHING AIR COMPRESSOR

GEORGE D. SULLIVAN
MARCH 1992

Approved for public release; distribution unlimited

Submitted by:

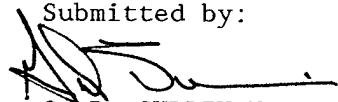
G. D. SULLIVAN
GS-11
Test Director

Reviewed by:

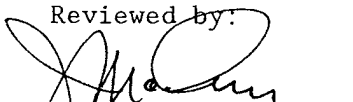
J. W. MCCARTHY
GM-14
Hyperbaric Engineer

Approved by:

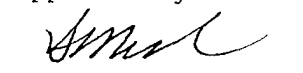
BERT MARSH
CDR, USN
Commanding Officer

B. D. MCKINLEY
LT. USN
Senior Projects Officer

J. R. CLARKE
GM-15
Scientific Director

J. R. CLARKE
GM-15

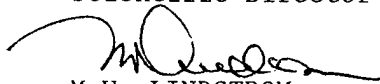
M. V. LINDSTROM
LCDR, USN
Executive Officer

REPORT DOCUMENTATION PAGE			
1a. REPORT SECURITY CLASSIFICATION UNCLASSIFIED		1b. RESTRICTIVE MARKINGS	
2a. SECURITY CLASSIFICATION AUTHORITY		3. DISTRIBUTION/AVAILABILITY OF REPORT DISTRIBUTION STATEMENT A: Approved for public release; distribution is unlimited	
2b. DECLASSIFICATION/DOWNGRADING SCHEDULE			
4. PERFORMING ORGANIZATION REPORT NUMBER(S) NEDU Report #1-92		5. MONITORING ORGANIZATION REPORT NUMBER(S)	
6a. NAME OF PERFORMING ORGANIZ. Navy Experimental Diving Unit	6b. OFFICE SYMBOL (If applicable)	7a. NAME OF MONITORING ORGANIZATION	
6c. ADDRESS (City, State, and ZIP Code) Panama City, Florida 32407-5001		7b. ADDRESS (City, State, and ZIP Code)	
8a. NAME OF FUNDING/SPONSORING ORGANIZATION Naval Sea Systems Command	6b. OFFICE SYMBOL (If applicable) OOC	9. PROCUREMENT INSTRUMENT IDENTIFICATION NUMBER	
8c. ADDRESS (City, State, and ZIP Code) Washington, D.C. 20362-5101		10. SOURCE OF FUNDING NUMBERS	
		PROGRAM ELEMENT NO.	PROJECT NO.
		TASK NO. 92-002 92-003	WORK UNIT ACCESSION NO.
11. TITLE (Include Security Classification) Evaluation of MAKO 5415 High Pressure Breathing Air Compressor			
12. PERSONAL AUTHOR(S) Mr. David Sullivan			
13a. TYPE OF REPORT FINAL	13b. TIME COVERED FROM _____ TO _____	14. DATE OF REPORT (Year,Month,Day) March 1992	15. PAGE COUNT 31
16. SUPPLEMENTARY NOTATION			
17. COSATI CODES		18. SUBJECT TERMS (Continue on reverse if necessary and identify by block number) MAKO 5415 Electric High Pressure Breathing Air Compressor	
FIELD	GROUP		
19. ABSTRACT (Continue on reverse if necessary and identify by block number) <p>In response to NAVSEA tasking, Navy Experimental Diving Unit (NEDU) tested the MAKO 5415 Electric, Powered High Pressure, Breathing Air Compressor and the MAKO MK-10-C Purification system from 27 Nov 1991 thru 16 Dec 1991. The objective of this testing was to determine if the compressor and the purification system functioned as specified and was suitable for addition to the Approved for Navy Use (ANU) List.</p> <p>The MAKO 5415 compressor and MK-10-C purification system met manufacturer's specifications for quantity of air produced and met or exceeded purity standards. The design and engineering were determined to be adequate. The MAKO 5415 compressor and MK-10-C purification system is considered suitable to meet the USN requirements for divers breathing air compressors of this size and type.</p>			
20. DISTRIBUTION/AVAILABILITY OF ABSTRACT <input type="checkbox"/> UNCLASSIFIED/UNLIMITED <input type="checkbox"/> SAME AS RPT. <input type="checkbox"/> DTIC USERS		21. ABSTRACT SECURITY CLASSIFICATION	
22a. NAME OF RESPONSIBLE INDIVIDUAL	22b. TELEPHONE (Include Area Code)	22c. OFFICE SYMBOL	

CONTENTS

	<u>Page</u>
I. INTRODUCTION.....	1
II. EQUIPMENT DESCRIPTION.....	1
III. TEST PROCEDURE RESULTS.....	5
A. ENDURANCE TEST.....	5
B. CHARGE RATES.....	7
C. OIL CONSUMPTION.....	7
D. AIR SAMPLING.....	8
E. MAINTENANCE.....	8
IV. CONCLUSIONS.....	8
V. REFERENCES.....	9
APPENDIX A - Test Log.....	A-1 thru A-13
APPENDIX B - Air Sample Results.....	B-1 thru B-3
APPENDIX C - Manufacture's Specifications.....	C-1 thru C-4

ILLUSTRATIONS

<u>Figure No.</u>		<u>Page No.</u>
1	Mako 5415 Compressor Description	2
2	The Air Purification System	4
3	NEDU test 91-50 Equipment Configuration	6

I. INTRODUCTION

In response to NAVSEA tasking¹⁻² a MAKO 5415 Electric Powered High Pressure, Breathing Air Compressor equipped with a MAKO MK-10-C purification system was delivered to the Navy Experimental Diving Unit (NEDU) and tested³ from 27 Nov 1991 thru 16 Dec 1991. The objective of this testing was to determine if the compressor and the purification system functioned as specified and was suitable for addition to the Approved for Navy Use (ANU) List⁴.

There are various methods of testing compressor capacities. For the purposes of this compressor test³ NEDU chose a test which consisted of charging four 36.87 liter (2250 cubic inch) (floodable volume) cylinders from 68.94 to 137.9 bars (1000 to 2000 psig) to determine charge rates. The unit was run daily, vented to atmosphere and adjusted to create a final discharge pressure ranging from 103.42 to 344.73 bars (1500 to 5000 psig) to simulate actual service use. The testing³ included subjective evaluation of the compressor and purification system operation, but did not include detailed mechanical review of the individual components of the system.

II. EQUIPMENT DESCRIPTION

A. GENERAL

The MAKO 5415 compressor (Figure 1) is a four stage, single acting, 90 degree Vee configuration, which provides complete primary balance.

Air enters the unit through a filter/silencer and is compressed by the first stage piston. It then passes through cooler tubes enroute to the second stage for further compression. This process is repeated through the third and fourth stages of compression. Cooling is accomplished by water flowing from the self-contained radiator system through the jackets and passages. After final cooling the air is delivered at the designed pressure to the system.

For this particular unit the prime mover was a Baldor 55.9 KW (75 horsepower), three phase 460/220 volt, electric motor. Rotational torque was transferred to the compressor by 2 V-belts. First and second stage pistons were of conventional design and, the third and fourth stages were of the crosshead type. Main bearings bushings, big end bearing halves and small end bearings were all replaceable.

Multi-stage coolers are fitted after each compression stage and are maintained through four access doors. First, second and third stage coolers are fixed, while the fourth stage has a removable tubestack.

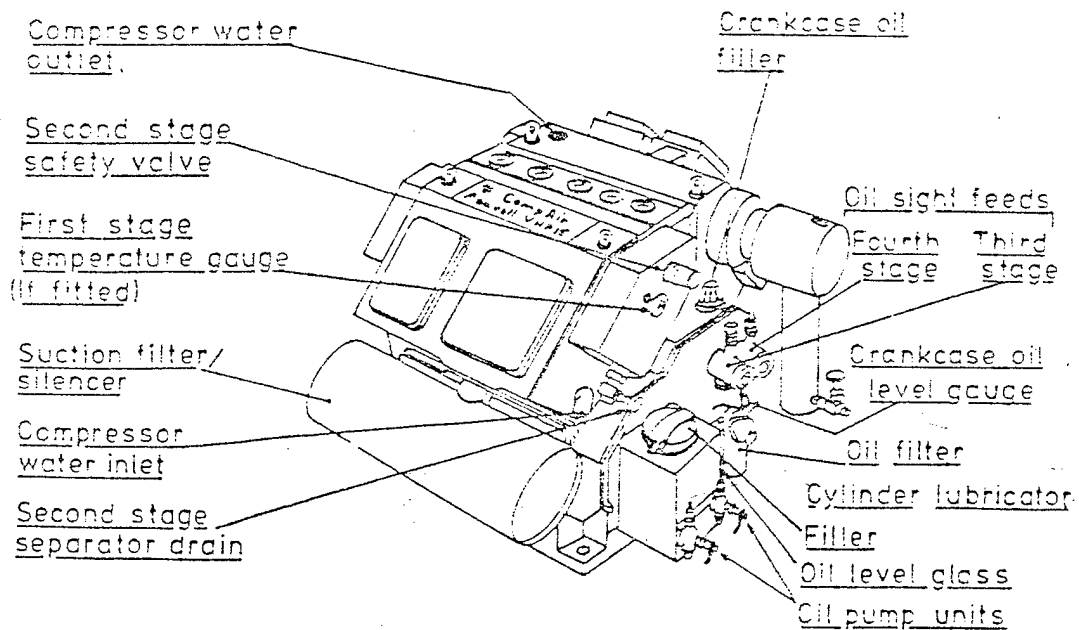
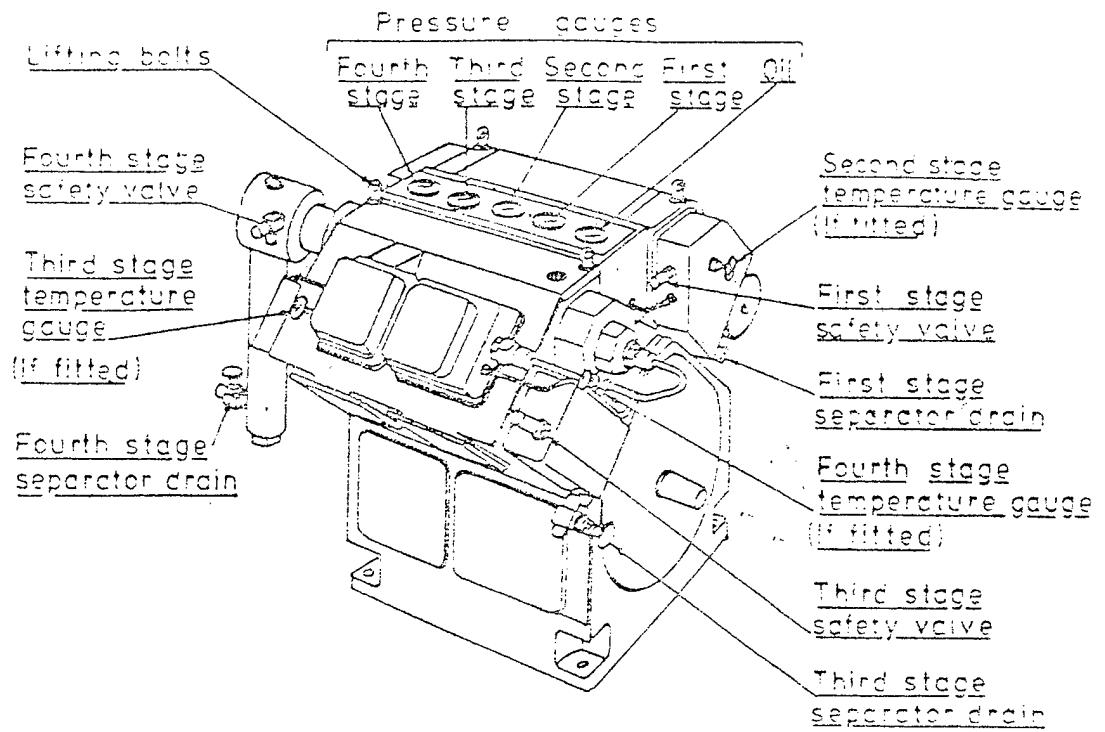

Compressor Description

Figure 1

All stage valves are of the flat plate, low lift, multi-ported type and combine both suction and delivery functions. Ease of access, by having one valve cover per cylinder, and good flow characteristics are features of this valve design.

B. LUBRICATION

The manufacturer recommends the compressor be "run-in" on normal mineral type oils (i.e. 2190 TEP) for approximately 100 hours before changing to a synthetic oil. One of the recommended synthetic oils is Anderol 500, which is stocked in the Federal Supply System.

A forced lubrication system is used to convey oil to the large end and main bearings via a filter and crankshaft passages. The connecting rods are drilled to supply oil to the smaller end bearings/bushings. Oil is forced through the bearing clearance and thrown off the rotating crankshaft to ensure an adequate supply to cylinders, pistons and small end bearings. Return flow oil is drawn through a strainer and excess pressure regulated by a spring loaded relief valve. Oil pressure is gauge indicated for the unit and sight feed glasses allow observation of the feed rate of the third and fourth stage mechanical lubricator.

The crankcase is filled through the filler plug on the main bearing housing and the oil level is indicated in a sight glass on the crankcase end plate. The cylinder lubricator tank has a lifting cap on top for filling purposes, except when an automatic top-up system is installed.

C. CONTROLS

For starting purposes, automatic or manual unloaders/drains are fitted to all stages. Automatic unloaders provide initial venting when starting and close as the compressor attains operational speed, opening again for condensate draining when the unit is shut down. A timer may be incorporated in the unloading circuit to effect timed drainage (compatible with environmental and operating conditions). High humidity requires more frequent draining. Pressure safety valves are fitted at each stage. An oil pressure gauge and air pressure gauges for each stage are mounted on a common panel. Low oil pressure and high temperature switches are standard equipment.

A bursting disc is installed to relieve excessive pressure build up or freezing water in the water passages. Excessive pressure or freezing will rupture the specified pressure disc to relieve internal pressure.

D. PURIFICATION SYSTEM

The air purification system consists of three cylinders that use replaceable cartridges (figure 2). After compression, air passes through

AIR PURIFICATION SYSTEMS

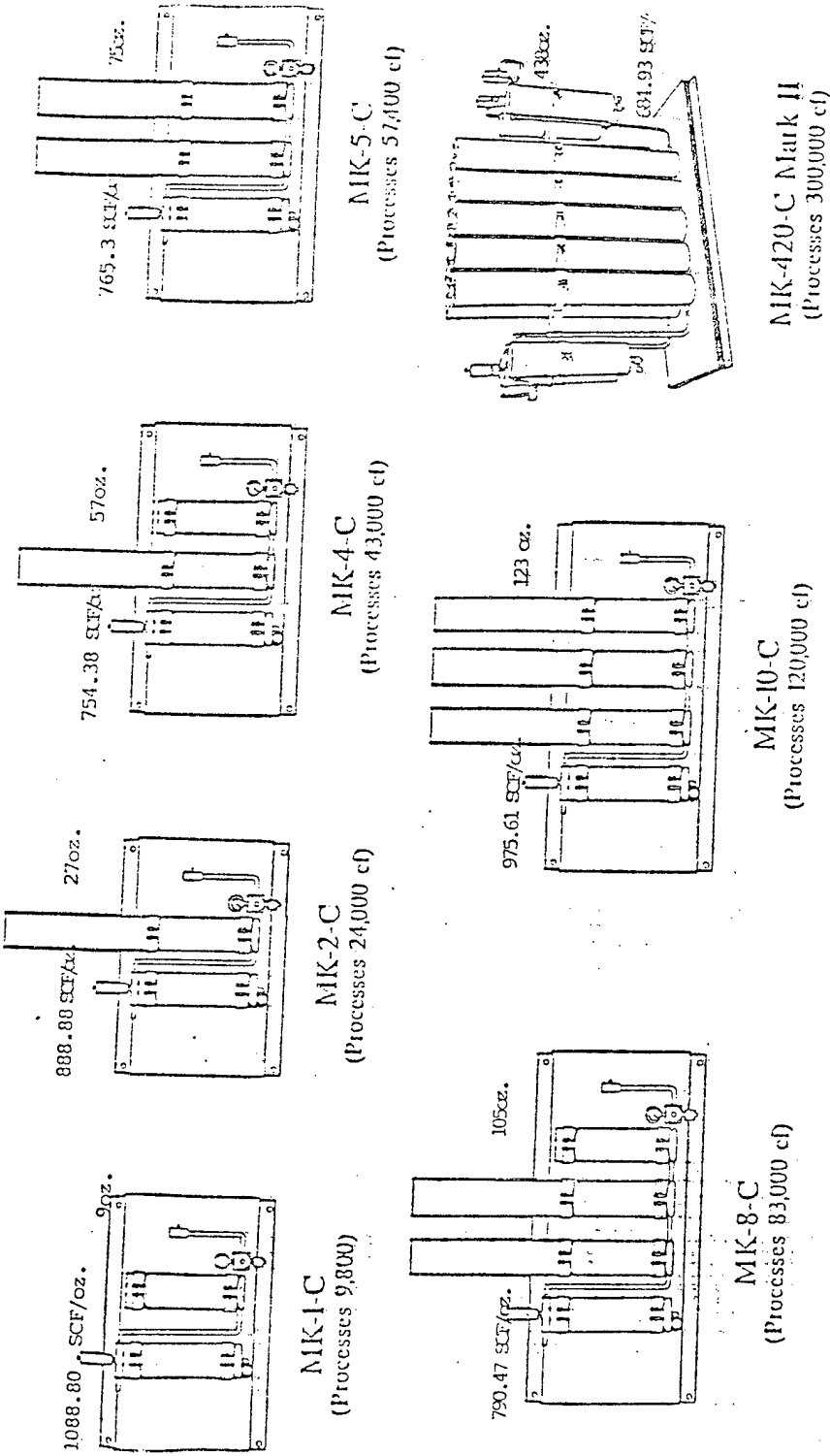

FIGURE 2

the separator and enters the dryer section of the purification process. Within the dryer, long chain hydrocarbons, moisture and vapors are removed by a chemical. Further processing removes objectionable odors and taste before the air enters a catalyst bed that converts carbon monoxide (CO) to carbon dioxide (CO₂).

III. TEST PROCEDURE RESULTS

The compressor and ancillary equipment were set up in accordance with the NEDU test plan³ and the Mako compressor and purification system manufacturer's publication⁶⁻⁷. A line diagram of the test configuration is depicted in (Figure 3). The unit was placed in an exterior work area, open to ambient temperature but protected by an awning from direct weather. A Digitech HT series, model 5820 temperature monitor and two Yellow Springs Instruments 700 series thermistor probes were attached to measure compressor discharge and ambient temperatures. An Ideal Humidity indicator, model 3310-20 was mounted near the compressor unit and the ambient humidity recorded. An MSA Toxgard carbon monoxide monitor with a flow range from 350 to 900 cc per minute was used to analyze compressor discharge air samples before and after the purification system. Nitrogen (100% N₂) and carbon monoxide (CO) 99.9 parts per million (ppm) in air were used to calibrate the monitor on a daily basis. The gases were fed through a Victor Equip Co. 4000 psig manual regulator to a Fischer and Porter flow meter. The introduction of CO was adjusted to maintain 50 PPM of CO at the entrance of the filtration system. Appendix A is the test log and contains the recorded data.

The Mako Compressor Maintenance Manual⁶ was used to conduct an initial receipt and inspection of the equipment to ensure that all parts and material were received. Main panel instruments and controls were clearly and permanently marked and easily viewed by the operator. Cooling water indicators were not identified.

A. ENDURANCE TEST

The compressor test was completed at 50 hours of operation. The unit continued to run for 75 hours to complete the purification system test. At the end of day 1 (5 hours) of operation the unit was secured with 172.4 bar (2500 psig) in the volume tanks. All vents, flowmeters, and blowdown valves were closed. The unit remained secured until 0630 the following day. The pressure drop was minimal, less than 13.8 bars (200 psig), and insignificant when temperature differentials were considered.

The compressor was operated daily with the discharge venting to atmosphere. The charge rate was verified by charging from 68.9 to 137.9 bar (1000 to 2000 psig) to the four interconnected flasks. Carbon monoxide was introduced directly into the air suction at the rate of 50 to 100 ppm. Throughout the 50 hours of testing the compressor discharge was continuously

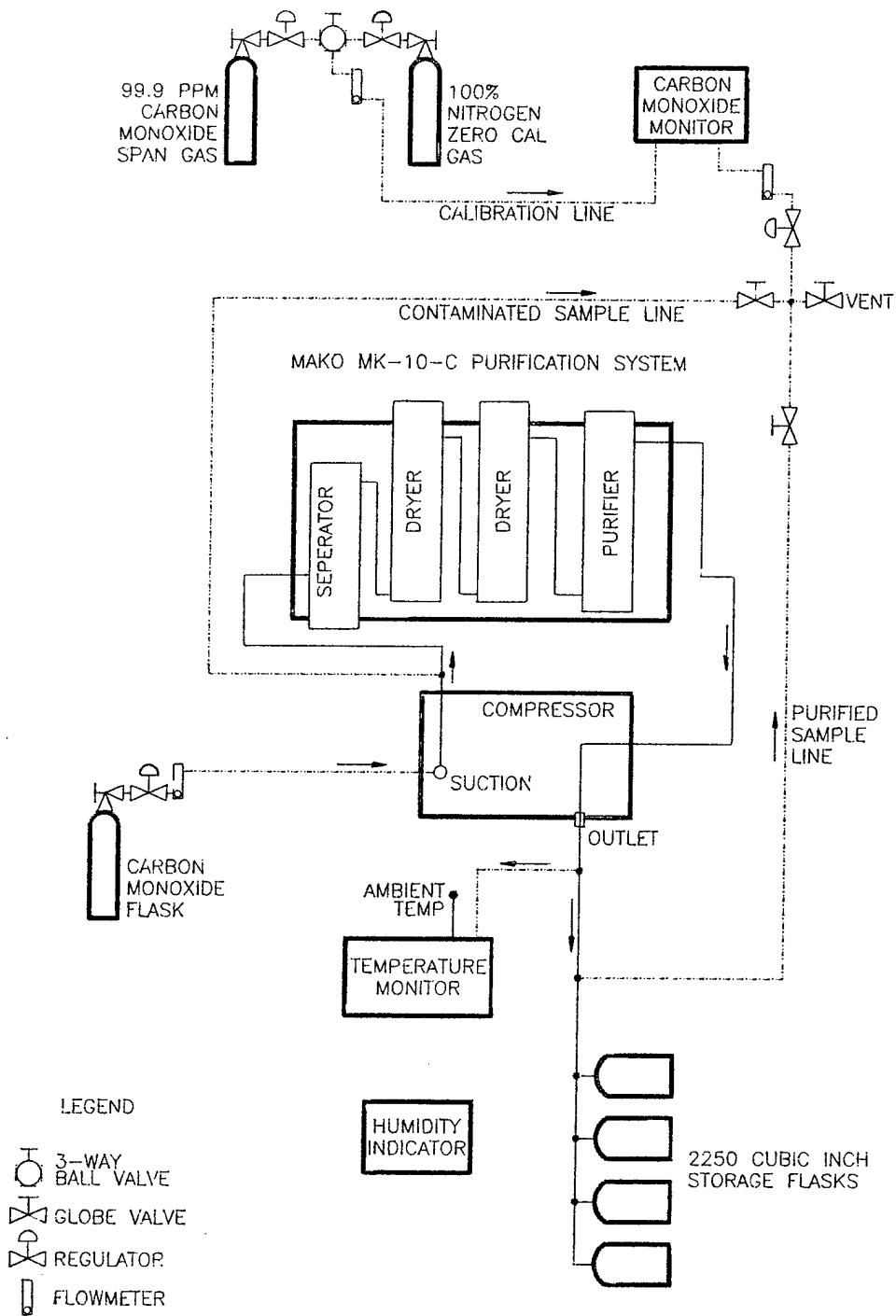

FIGURE 3: NEDU TEST 91-50 EQUIPMENT CONFIGURATION

analyzed. Samples were taken before and after the purification system. These readings are located in Appendix A. A total of 50 hours of operation was logged.

The following parameters were recorded:

1. Date.
2. Time.
3. Total Meter Hours.
4. Total Test Hours.
5. Ambient Humidity.
6. Ambient Temperature.
7. Compressor Oil Pressure.
8. Stage pressures 1 thru 4.
9. Discharge line temperature.
10. Carbon Monoxide Before Filter.
11. Carbon Monoxide After Filter.
12. Water Pressure
13. Water Temperature Inlet.
14. Water Temperature 3rd Stage.

Oil and water levels were checked each morning prior to start up.

B. CHARGE RATES

The volume of air delivered and the time to achieve that volume was logged. The data collected provided a complete operational and maintenance log for this test and was the basis for computing and evaluating all the test results. Compressor charge rate for the air flasks used during the test is as follows:

	<u>TIME</u>	<u>TOTAL VOLUME</u>	<u>CHARGE RATE</u>
MINIMUM:	11.06 MINUTES	10.2 METER ³ (359 FEET ³)	0.920 ACM/M (32.45 ACFM)
MAXIMUM:	12.11 MINUTES	10.2 METERS ³ (359 FEET ³)	0.839 ACM/M (29.64 ACFM)
AVERAGE:	11.58 MINUTES	10.2 METERS ³ (359 FEET ³)	0.878 ACM/M (31.00 ACFM)

C. OIL CONSUMPTION

The unit had been operated by the manufacturer for 1.4 hours prior to shipment. The NEDU evaluation was conducted with the oil as delivered in the crankcase. Oil level was checked daily prior to start up. At 50 hours 1 quart of oil was added to the unit.

D. AIR SAMPLING

All samples for the 50 hour compressor test were within established limits⁵. The results of air samples taken after 5, 25, and 50 hours of operation are shown in Appendix B. These samples were taken from the downstream side of the Mk-10-C purification system while CO was being introduced into the inlet of the compressor. A final sample taken at 75 hours of operation revealed that the purification system catalyst had broken-down (results are shown in Appendix B).

E. MAINTENANCE

Scheduled maintenance was performed in accordance with the manufacturer's instructions and consisted of a normal adjustment of new drive belts after the initial 24 hours of operation. The MAKO 5415 compressor unit was easily maintained. The maintenance manual for the compressor provides a very good breakdown of the 5415 block components. It does not provide additional information concerning control components.

IV. CONCLUSIONS

Evaluation of the MAKO 5415 compressor revealed the following:

1. The MAKO 5415 compressor delivers acceptable breathing air at a charge rate and volume which meets or exceeds the manufacturer's specifications.
3. The Mk-10C purification system in conjunction with the Mako 5415 compressor produced 143,300.4 cubic feet of clean compressed air for 138% of its expected life.
2. The unit is sturdy, reliable and readily maintained.
3. The operating and maintenance manuals for the compressor are lacking information for complete maintenance and setting of control components.
4. The MAKO 5415 compressor is suitable for use by the US. NAVY.

V. REFERENCES

1. NAVSEA Task 91-002; Evaluation of commercially available divers air compressors. Navy Experimental Diving Unit
2. NAVSEA Task 92-003; Evaluation of commercially available filters for H.P. and L.P. breathing air. Navy Experimental Diving Unit
3. Navy Experimental Diving Unit Test Plan Number 91-50; Mako 5415 Electric Drive High Pressure Air Compressor and MK-10-C Purification System Evaluation (unmanned), Nov 91
4. Authorized for Navy Use, NAVSEAINST 10560.2B
5. NAVSEA 0994-LP001-9010, U. S. Navy Diving Manual V.1 Rev 2, Para 5.3.2 Air Purity Standards, Dec 88
6. MAKO publication number VHP15, 5415,5415BA for Model 5415 Electric Drive High Pressure Air Compressor. Mako 1634 S.W. 17th street P.O. Drawer 1630 Ocala, Florida 32678 (904) 732-2268
7. MAKO publication, Purification parts and instruction manual. Mako 1634 S.W. 17th street P.O. Drawer 1630 Ocala, Florida 32678 (904) 732-2268

MAKO DIVERS AIR COMPRESSOR
MODEL 5415

DATE NOV 27, 1991

REAL TIME	TEST HOUR	TOTAL METER HOURS	COOLING WATER		STAGE PRESSURES				OIL PRES	TEMPS °F		PPM FILTER AFT	CO PRE	HUMD	
			IN TEMP	OUT TEMP	1	2	3	4		AMBI	DSCHG				
0830	00	01.4	50	50	24	50	250	1000	3200	45	53.4°	65.7°	-1	44	60%
0930	01	02.4	72	108	27	54	275	1100	4300	45	55.9°	95.3°	-2	52	58%
1030	02	03.4	74	108	28	52	275	1100	4700	45	60.6°	98.8°	0	52	50%
1130	03	04.4	74	108	28	52	275	1100	5000	45	60.2°	96.2°	0	50	54%
1230	04	05.4	78	110	28	52	275	1100	5000	45	59.6°	100.5°	0	48	55%
1330	05	06.4	80	110	28	52	275	1100	4800	45	69.4°	101.1°	-2	47	52%

REMARKS AND COMMENTS

CHECK OIL AND WATER LEVELS PRIOR TO STARTUP
 0930 TOOK A CHARGE RATE FROM 1000 TO 2000PSIG 12.30 MINUTES = 29.11 CFM
 TOOK AIR SAMPLE AT 5 HOURS
 AVERAGE AIR TEMP 11-27-91 AMBIENT = 59.85°F DISCHARGE = 92.93°F
 AVERAGE FINAL PRESSURE 4500 PSIG
 AIR PROCESSED 11-27-91 29.11CFM x 60 x 5 = 8,733 TOTAL CUBIC FEET

MAKO DIVERS AIR COMPRESSOR
MODEL 5415

DATE NOV 29 1991

REAL TIME	TEST HOUR	TOTAL METER HOURS	COOLING WATER		STAGE PRESSURES				OIL PRES	TEMPS °F			PPM CO FILTER AFT	PPM CO FILTER PRE	HUMID
			IN TEMP	OUT TEMP	1	2	3	4		AMBI	DCHG	HUMD			
0630	05	06.4	60	60	24	50	275	1200	4200	45	59.0°	63.0°	0	44	99%
0730	06	07.4	80	110	26	52	275	1160	3400	45	60.3°	96.5°	0	54	95%
0830	07	08.4	80	110	26	52	275	1160	4500	45	63.1°	97.3°	-1	51	89%
0930	08	09.4	80	110	26	52	275	1090	4500	45	64.8°	94.8°	0	50	85%
1030	09	10.4	84	110	26	52	275	1090	4900	45	70.0°	96.4°	-1	52	85%
1130	10	11.4	86	112	26	52	275	1090	4850	45	67.7°	98.9°	0	46	80%
1230	11	12.4	90	112	26	52	275	1090	5000	45	72.8°	107.1°	0	48	74%
1330	12	13.4	92	114	28	52	260	1050	5000	45	75.4°	105.8°	-1	51	75%
1400	12.5	13.9	92	114	28	52	275	1090	3400	45	74.6°	104.4°	0	48	78%

REMARKS AND COMMENTS

CHECK OIL AND WATER LEVELS PRIOR TO STARTUP
0935 TOOK CHARGE RATE FROM 1000 PSI TO 2000 PSI 12.12 MINUTES = 29.53 CFM
AVERAGE AIR TEMPERATURE 11-29-91 AMBIENT = 67.52°F DISCHARGE = 96.02°F
AVERAGE FINAL PRESSURE 4416 PSIG
AIR PROCESSED FOR 11-29-91 = 29.53CFM X 60 X 7.5 = 13,288.5 CUBIC FEET
AIR PROCESSED TO DATE = 8,733 + 13,288.5 = 22,021.5 TOTAL CUBIC FEET

MAKO DIVERS AIR COMPRESSOR
MODEL 5415

DATE DEC 02 1991

REAL TIME	TEST HOUR	TOTAL METER HOURS	COOLING WATER		STAGE PRESSURES				OIL PRES	TEMPS °F			PPM CO FILTER		HUMD
			IN TEMP	OUT TEMP	1	2	3	4		AMBI	DSCHG	AFT	PRE		
1000	12.5	13.9	71	82	26	52	265	1000	3200	45	73.4°	95.2°	-2	48	90%
1100	13.5	14.9	90	112	26	52	270	1500	3200	45	73.0°	103.4°	0	52	86%
1200	14.5	15.9	90	112	26	52	275	1500	3200	45	74.9°	106.0°	0	49	76%
1300	15.5	16.9	94	116	26	52	270	1020	4500	45	74.2°	106.3°	-1	50	76%
1400	16.5	17.9	94	116	26	52	270	1020	5000	45	75.1°	105.2°	0	49	83%

REMARKS AND COMMENTS

CHECK OIL AND WATER LEVELS PRIOR TO STARTUP
 1130 TOOK CHARGE RATE 1000 PSI TO 2000 PSI IT TOOK 12.03 MINUTES = 29.75 CFM
 AVERAGE AIR TEMPERATURE 12-02-91 AMBIENT = 74.12°F DISCHARGE = 103.22°F
 AVERAGE FINAL PRESSURE 3820 PSIG
 AIR PROCESSED 12-02-91 = 29.75CFM X 60 X 4 = 7,142.4 CUBIC FEET
 TOTAL AIR PROCESSED TO DATE = 22,021.5 + 7,142.4 = 29,163.9 TOTAL CUBIC FEET

MAKO DIVERS AIR COMPRESSOR
MODEL 5415

DATE DEC 03 1991

REAL TIME	TEST HOUR	TOTAL METER HOURS	COOLING WATER		STAGE PRESSURES				OIL PRES	TEMPS °F		PPM CO FILTER AFT	PRE	HUMD
			IN TEMP	OUT TEMP	1	2	3	4		AMBI	DCHG			
0700	16.5	17.9	70	70	50	240	900	2200	45	70.6°	80.2°	-1	44	100%
0800	17.5	18.9	80	110	52	270	1090	3100	45	68.2°	94.6°	0	47	100%
0900	18.5	19.9	80	110	52	275	1090	3200	45	67.1°	107.2°	0	51	96%
1000	19.5	20.9	80	110	52	270	1050	3200	45	68.2°	103.4°	-2	49	96%
1100	20.5	21.9	82	110	52	270	1050	5000	45	68.4°	106.2°	0	48	88%
1130	21.0	22.4	82	110	52	275	1090	4800	45	67.2°	106.4°	-1	46	86%
1300	21.0	22.4	64	98	52	270	1020	4800	45	62.3°	86.4°	0	50	90%
1400	22.0	23.4	76	108	52	270	1020	5000	45	64.9°	99.2°	0	48	78%
1500	23.0	24.4	72	108	52	275	1030	3250	45	62.0°	97.6°	-1	44	78%

REMARKS AND COMMENTS

CHECK OIL AND WATER LEVEL PRIOR TO STARTUP
UNIT WAS SECURED AT 1130 AND RESTARTED AT 1300
1305 TOOK CHARGE RATE IT TO 11.53 MINUTES TO CHARGE FROM 1000 TO 2000 PSI = 31.05 CFM
AVERAGE AIR TEMPERATURE 12-03-91 AMBIENT = 66.54°F DISCHARGE = 97.91°F
AVERAGE FINAL PRESSURE 3838 PSIG
AIR PROCESSED 12-03-91 = 31.05 X 60 X 6.5 = 12,109.5 CUBIC FEET
TOTAL AIR PROCESSED TO DATE = 29,163.9 + 12,109.5 = 41,273.4 TOTAL CUBIC FEET

MAKO DIVERS AIR COMPRESSOR
MODEL 5415

DATE DEC 04 1991

REAL TIME	TEST HOUR	TOTAL METER HOURS	COOLING WATER		STAGE PRESSURES				OIL PRES	TEMPS °F		PPM CO FILTER AFT	PRE HUMD	
			IN TEMP	OUT TEMP	1	2	3	4		AMBI	DCHG			
0630	23.0	24.4	40	40	25	260	1030	3500	45	40.1°	47.2°	0	54	84%
0730	24.0	25.4	58	102	26	275	1050	3400	45	45.5°	91.4°	-1	52	80%
0830	25.0	26.4	58	104	26	275	1050	3300	45	45.0°	91.8°	0	48	78%
0930	26.0	27.4	60	104	25	275	1060	3300	45	48.2°	96.6°	-1	46	62%
1030	27.0	28.4	62	104	25	275	1050	3300	45	49.8°	93.6°	0	50	58%
1130	28.0	29.4	64	104	28	270	980	2500	45	53.3°	92.1°	+1	51	52%
1230	29.0	30.4	68	106	28	275	1150	4500	45	51.6°	95.0°	-1	48	48%
1330	30.0	31.4	70	106	28	275	1110	4200	45	55.3°	96.5°	+2	50	46%
1400	30.5	31.9	70	106	28	275	1110	4500	45	58.9°	98.8°	+1	52	46%

REMARKS AND COMMENTS

CHECK OIL AND WATER LEVEL PRIOR TO STARTUP ADJUSTED DRIVE BELTS
 CHARGE RATE IT TOOK 11.06 MINUTES TO CHARGE FROM 1000 PSI TO 2000 PSI = 32.37 CFM
 0830 TOOK 25 HR AIR SAMPLE
 AVERAGE AIR TEMPERATURE 12-04-91 AMBIENT = 49.74° F DISCHARGE = 89.22° F
 AVERAGE FINAL PRESSURE 3277 PSIG
 AIR PROCESSED 12-04-91 = 32.37CFM X 60 X 7.5 = 14,566.5 CUBIC FEET
 TOTAL AIR PROCESSED TO DATE = 41,273.4 + 14,566.5 = 55,839.9 TOTAL CUBIC FEET

MAKO DIVERS AIR COMPRESSOR
MODEL 5415

DATE DEC 05 1991

REAL TIME	TEST HOUR	TOTAL METER HOURS	COOLING WATER		STAGE PRESSURES				OIL PRES	TEMPS °F		PPM CO FILTER AFT	PPM CO FILTER PRE	HUMID
			IN TEMP	OUT TEMP	1	2	3	4		AMBI	DSCHG			
0700	30.5	31.9	40	40	25	52	270	1000	3400	45	38.2°	52.0°		88%
0800	31.5	32.9	56	102	26	52	280	1100	3600	45	40.8°	86.3°	+5	86%
0900	32.5	33.9	58	104	26	52	280	1100	3600	45	44.4°	88.2°	+4	74%
1000	33.5	34.9	62	104	26	52	260	1090	4300	45	47.3°	91.4°	+4	61%
1100	34.5	35.9	66	104	28	52	280	1110	4400	45	50.3°	92.2°	+5	52%
1200	35.5	36.9	66	104	26	52	280	1150	5050	45	51.4°	96.1°	+4	48%
1300	36.5	37.9	68	108	26	52	285	1180	4200	45	61.2°	98.8°	+5	47%

REMARKS AND COMMENTS

CHECK OIL AND WATER LEVEL PRIOR TO STARTUP
 TOOK CHARGE RATE IT TOOK 11.53 MINUTES TO CHARGE FROM 1000 PSI TO 2000 PSI = 31.05 CFM
 AVERAGE AIR TEMPERATURE 12-05-91 AMBIENT = 46.66°F DISCHARGE = 86.43°F
 AVERAGE FINAL PRESSURE 4078 PSIG
 AIR PROCESSED 12-05-91 = 31.05 X 60 X 6 = 11,178 CUBIC FEET
 TOTAL AIR PROCESSED TO DATE = 55,839.9 + 11,178 = 67,017.9 TOTAL CUBIC FEET

MAKO DIVERS AIR COMPRESSOR
MODEL 5415

DATE DEC 06 1991

REAL TIME	TEST HOUR	TOTAL METER HOURS	COOLING WATER		STAGE PRESSURES				OIL PRES	TEMPS °F		PPM CO FILTER PRE	AFT	HUMD
			IN TEMP	OUT TEMP	1	2	3	4		AMBI	DSCHG			
0930	36.5	37.9	52	52	26	52	275	1110	4000	45	54.3°	52.3°		76%
1030	37.5	38.9	72	108	26	52	275	1090	3500	45	58.8°	91.1°	0	59%
1130	38.5	39.9	72	108	26	52	275	1090	3500	45	63.3°	99.6°	+1	60%
1230	39.5	40.9	78	110	27	52	275	1080	3400	45	61.6°	101.6°	+1	56%
1330	40.5	41.9	80	110	27	52	275	1110	3600	45	63.3°	104.8°	+1	55%
1430	41.5	42.9	82	110	27	52	275	1150	3900	45	64.8°	104.6°	+4	54%

REMARKS AND COMMENTS

CHECK OIL AND WATER LEVELS PRIOR TO STARTUP
 TOOK CHARGE RATE IT TOOK 11.43 MINUTES TO CHARGE FROM 1000 PSI TO 2000 PSI = 31.32 CFM
 AVERAGE AIR TEMPERATURE 12-06-91 AMBIENT = 61.02°F DISCHARGE = 92.3°F
 AVERAGE FINAL PRESSURE 3650 PSIG
 AIR PROCESSED 12-06-91 = 31.32CFM X 60 X 5 = 9,396 CUBIC FEET
 TOTAL AIR PROCESSED TO DATE = 67,017.9 + 9,396 = 76,413.9 TOTAL CUBIC FEET

MAKO DIVERS AIR COMPRESSOR
MODEL 5415

DATE DEC 09 1991

REAL TIME	TEST HOUR	TOTAL METER HOURS	COOLING WATER		STAGE PRESSURES				OIL PRES	TEMPS °F		PPM CO FILTER PRE	AFT	HUMD
			IN TEMP	OUT TEMP	1	2	3	4		AMBI	DSCHG			
0700	41.5	42.9	64	64	26	52	250	1000	3000	45	65.6°	65.3°		100%
0800	42.5	43.9	84	110	26	52	270	1100	3500	45	74.8°	105.5°	-2	90%
0900	43.5	44.9	84	112	26	52	275	1100	3500	45	76.5°	110.8°	-1	92%
1000	44.5	45.9	90	114	26	52	275	1100	4500	45	78.1°	112.6°	+2	86%
1100	45.5	46.9	90	114	26	52	275	1100	5000	45	76.8°	110.0°	0	84%
1200	46.5	47.9	90	114	26	52	275	1100	5000	45	78.6°	108.2°	-2	88%
1300	47.5	48.9	90	114	26	52	275	1100	4900	45	77.4°	110.3°	0	87%

REMARKS AND COMMENTS

CHECK OIL AND WATER LEVELS PRIOR TO STARTUP
 TOOK CHARGE RATE IT TOOK 12.08 MINUTES TO CHARGE FROM 1000 PSI TO 2000 PSI = 29.64 CFM
 AVERAGE AIR TEMPERATURE 12-09-91 AMBIENT = 75.4°F DISCHARGE = 103.24°F
 AVERAGE FINAL PRESSURE 4200 PSIG
 AIR PROCESSED 12-09-91 = 29.64CFM X 60 X 6 = 10,670.4 CUBIC FEET
 TOTAL AIR PROCESSED TO DATE = 76,413.9 + 10,670.4 = 87,084.3 TOTAL CUBIC FEET

MAKO DIVERS AIR COMPRESSOR
MODEL 5415

DATE DEC 10 1991

REAL TIME	TEST HOUR	TOTAL METER HOURS	COOLING WATER		STAGE PRESSURES				OIL PRES	TEMPS °F		PPM CO FILTER PRE	AFT	HUMD	
			IN TEMP	OUT TEMP	1	2	3	4		AMBI	DSCHG				
0700	47.5	48.9	60	60	26	52	260	800	1500	45	60.4°	60.5°		93%	
0800	48.5	49.9	76	108	26	52	275	1060	3400	45	65.3°	99.3°	+2	54	92%
0900	49.5	50.9	78	110	26	52	280	1100	3450	45	63.3°	98.7°	+4	56	83%
0930	50.0	51.4	78	110	26	52	280	1100	3500	45	63.9°	98.7°	+2	55	80%
1000	50.5	51.9	80	110	26	52	280	1110	3500	45	66.3°	102.6°	+3	53	76%
1100	51.5	52.9	80	110	26	52	280	1110	3700	45	69.1°	102.4°	+2	49	70%
1200	52.5	53.9	80	110	26	52	280	1110	3700	45	70.6°	105.2°	+3	50	68%
1300	53.5	54.9	84	112	24	52	280	1100	3600	45	73.8°	107.6°	+2	51	58%
1330	54.0	55.4	86	114	24	52	275	1100	3600	45	76.7°	111.9°	+6	53	55%

REMARKS AND COMMENTS

CHECK OIL AND WATER LEVELS PRIOR TO STARTUP
 TOOK CHARGE RATE IT TOOK 12.06 MINUTES TO CHARGE FROM 1000 PSI TO 2000 PSI = 29.68 CFM
 AVERAGE AIR TEMPERATURE 12-10-91 AMBIENT = 67.71°F DISCHARGE = 98.54°F
 AVERAGE FINAL PRESSURE 3327 PSIG
 0930 THE COMPRESSOR TEST WAS COMPLETE, CONTINUED THE PURIFICATION SYSTEM TEST.
 AIR PROCESSED 12-10-91 29 = 29.68 CFM X 60 X 6.5 = 11,575.2 CUBIC FEET
 TOTAL AIR PROCESSED TO DATE = 87,084.3 + 11,575.2 = 98,659.5 TOTAL CUBIC FEET

MAKO DIVERS AIR COMPRESSOR
MODEL 5415

DATE DEC 11 1991

REAL TIME	TEST HOUR	TOTAL METER HOURS	COOLING WATER		STAGE PRESSURES				OIL PRES	TEMPS °F		PPM CO FILTER AFT	PPM CO FILTER PRE	HUMID
			IN TEMP	OUT TEMP	1	2	3	4		AMBI	DCHG			
0800	54.0	55.4	58	58	25	52	275	1050	3600	45	55.1°	61.2°	+4	99%
0900	55.0	56.4	80	110	25	52	280	1120	3750	45	66.5°	102.1°	+4	78%
1000	56.0	57.4	84	112	25	52	285	1150	4000	45	72.5°	109.7°	+4	70%
1100	57.0	58.4	84	112	25	52	285	1190	4100	45	76.8°	107.4°	+2	66%
1200	58.0	59.4	88	116	25	52	285	1160	4100	45	71.2°	106.6°	+3	67%
1300	59.0	60.4	88	116	25	52	285	1160	4100	45	79.8°	109.1°	+3	61%
1400	60.0	61.4	88	116	25	52	285	1160	4000	45	80.7°	111.0°	+5	67%

REMARKS AND COMMENTS

CHECK OIL AND WATER LEVELS PRIOR TO STARTUP
 CHARGE RATE IT TOOK 11 16 MINUTE TO CHARGE FROM 1000 PSI TO 2000 PSI = 32.08 CFM
 AVERAGE AIR TEMPERATURE 12-11-91 AMBIENT = 71.8°F DISCHARGE = 101.01°F
 AVERAGE FINAL PRESSURE 3950 PSIG
 AIR PROCESSED 12-11-91 = 32.08 CFM X 60 X 6 = 11,548.8 CUBIC FEET
 TOTAL AIR PROCESSED TO DATE = 98,659.5 + 11,548.8 = 110,208.3 TOTAL CUBIC FEET

MAKO DIVERS AIR COMPRESSOR
MODEL 5415

DATE DEC 12 1991

REAL TIME	TEST HOUR	TOTAL METER HOURS	COOLING WATER		STAGE PRESSURES				OIL PRES	TEMPS °F		PPM CO FILTER AFT	PRE HUMD		
			IN TEMP	OUT TEMP	1	2	3	4		AMBI	DCHG				
0730	60.0	61.4	60	60	25	52	270	1080	3700	45	58.4°	64.5°		100%	
0830	61.0	62.4	80	110	25	52	280	1100	3750	45	60.7°	97.2°	+1	44	96%
0930	62.0	63.4	80	112	25	52	280	1120	3750	45	62.4°	97.3°	+7	46	94%
1030	63.0	64.4	82	112	25	52	280	1120	3700	45	65.8°	102.8°	+5	48	85%
1130	64.0	65.4	84	112	25	52	280	1100	3600	45	66.3°	102.1°	+7	48	84%
1230	65.0	66.4	86	112	25	52	275	1100	3600	45	66.6°	104.3°	+8	50	86%
1330	66.0	67.4	86	112	25	52	275	1110	3650	45	68.4°	101.7°	+2	46	82%
1430	67.0	68.4	86	114	25	52	175	1100	3500	45	68.6°	103.6°	+6	44	85%

REMARKS AND COMMENTS

CHECK OIL AND WATER LEVEL PRIOR TO START UP
 TOOK CHARGE RATE IT TOOK 11.75 MINUTES TO CHARGE FORM 1000 TO 2000 = 30.47 CFM
 AVERAGE AIR TEMPERATURE 12-12-91 AMBIENT = 64.65°F DISCHARGE = 96.69°F
 AVERAGE FINAL PRESSURE 3656 PSIG
 AIR PROCESSED 12-12-91 = 30.47 CFM X 60 X 7 = 12,797.4 CUBIC FEET
 TOTAL AIR PROCESSED TO DATE = 110,208.3 + 12,797.4 = 123,005.7 TOTAL CUBIC FEET

MAKO DIVERS AIR COMPRESSOR
MODEL 5415

DATE DEC 13 1991

REAL TIME	TEST HOUR	TOTAL METER HOURS	COOLING WATER		STAGE PRESSURES				OIL PRES	TEMPS °F		PPM CO FILTER AFT PRE	HUMID	
			IN TEMP	OUT TEMP	1	2	3	4		AMBI	DSCHG			
0700	67.0	68.4	60	60	25	52	260	1050	3700	45	59.8°	59.9°	-	100%
0800	68.0	69.4	80	110	25	52	275	1080	4500	45	66.7°	100.4°	+8	100%
0900	69.0	70.4	80	110	25	52	275	1080	5050	45	63.5°	101.3°	+9	96%
1000	70.0	71.4	82	110	25	52	275	1080	5000	45	70.6°	103.6°	+5	94%
1100	71.0	72.4	86	112	25	52	275	1080	4850	45	71.8°	106.1°	+4	85%
1200	72.0	73.4	86	112	25	52	275	1080	4800	45	70.9°	105.8°	+4	82%
			80											
			80											
			80											

REMARKS AND COMMENTS

CHECK OIL AND WATER LEVEL PRIOR TO STARTUP
 TOOK CHARGE RATE IT TOOK 11.50 MINUTES TO CHARGE FORM 1000 TO 2000 = 31.13 CFM
 AVERAGE AIR TEMPERATURE 12-13-91 AMBIENT = 67.21°F DISCHARGE = 96.18°F
 AVERAGE FINAL PRESSURE 4650 PSIG
 AIR PROCESSED 12-13-91 = 31.13 CFM X 60 X 5 = 9,339 CUBIC FEET
 TOTAL AIR PROCESSED TO DATE = 123,005.7 + 9,339 = 132,344.7 TOTAL CUBIC FEET

MAKO DIVERS AIR COMPRESSOR
MODEL 5415

DATE DEC 16 1991

REAL TEST HOUR TIME	TOTAL METER HOURS	COOLING WATER		STAGE PRESSURES				OIL PRES	TEMPS °F		PPM CO FILTER		HUMD	
		IN TEMP	OUT TEMP	1	2	3	4		AMBI	DSCHG	AFT	PRE		
0700	72.0	73.4	46	46	24	52	260	1000	3200	45	44.5°	44.7°		64%
0800	73.0	74.4	60	104	25	52	280	1090	3400	45	49.0°	92.8°	18	52
0900	74.0	75.4	64	106	25	52	280	1090	3400	45	53.3°	91.7°	18	49
1000	75.0	76.4	68	108	25	52	280	1090	3400	45	52.9°	91.7°	24	48
1100	76.0	77.4	70	108	25	52	280	1090	3300	45	54.2°	91.9°	26	49
1200	77.0	78.4	72	108	25	52	280	1100	4700	45	58.6°	97.8°	31	51
1250	77.5	79.2	74	108	25	52	280	1110	5000	45	60.0°	98.2°	44	52
			60											
			64											

REMARKS AND COMMENTS

CHECK OIL AND WATER LEVELS PRIOR TO STARTUP
 0905 TOOK CHARGE RATE IT TOOK 11.43 MINUTES TO CHARGE FROM 1000 TO 2000 PSI = 31.32 CFM
 AVERAGE AIR TEMPERATURE 12-16-91 AMBIENT = 53.21°F / FOR TEST PERIOD = 63.5°F
 AVERAGE AIR TEMPERATURE 12-16-91 DISCHARGE = 86.97°F / FOR TEST PERIOD = 95.44°F
 AVERAGE FINAL PRESSURE 3771 PSIG / FOR TEST PERIOD 3933 PSIG
 AIR PROCESSED 12-16-91 = 31.32 CFM X 60 X 5.83 = 10,955.7 CUBIC FEET
 TOTAL AIR PROCESSED TO DATE = 132,344.7 + 10,955.7 = 143,300.4 TOTAL CUBIC FEET
 CONSIDERING THE ABOVE LISTED AVERAGE TEMPERATURES AND PRESSURES A MOISTURE REMOVAL
 CAPACITY OF 840 CUBIC FEET OF AIR PER OUNCE OF SIEVE IS CALCULATED. THE MK-10-C SYSTEM
 CONTAINS 123 OZ. THIS EQUATES TO A EXPECTED "CORRECTED LIFE EXPECTANCY OF 103,320
 CUBIC FEET. TAKING THIS INTO CONSIDERATION THE MK-10-C EXCEEDED ITS EXPECTED LIFE BY
 38%



Memorandum

5 December 1991

To: Dave Sullivan, EDU

From: G. Deason, Code 5130

Subject: Analysis of air samples from NEDU test #91-50. Mako
5415 compressor evaluation.

1. In accordance with your request, the air samples delivered to the gas analysis lab were analyzed, and found to contain the following:

Component	5 Hr. Test	25 Hr. Test
Oxygen	21%	21%
Nitrogen	78.1%	78.1%
Argon	0.9%	0.9%
Carbon Dioxide	389 PPM	366 PPM
Carbon Monoxide	4.4 PPM	4.7 PPM
Total Hydrocarbons*	1.4 PPM	1.4 PPM
Total Halogens**	<0.5 PPM	<0.5 PPM
Methane	1.4 PPM	1.4 PPM
Acetylene	<0.1 PPM	<0.1 PPM
Freon 113	<0.1 PPM	<0.1 PPM
Methyl Ethyl Ketone	<0.1 PPM	<0.1 PPM
Benzene	<0.1 PPM	<0.1 PPM
Toluene	<0.1 PPM	<0.1 PPM
Methylchloroform	<0.1 PPM	<0.1 PPM
C4+	<0.1 PPM	<0.1 PPM

*Expressed as methane equivalents

** Expressed as methyl chloride equivalents.

2. The above samples showed no appreciable contamination; all components were within the acceptable range (as per the U.S. Navy Diving Air Handbook).

Glen Deason
Chemist



Memorandum

10 December 1991

To: Dave Sullivan, NEDU

From: G. Deason, Code 5130

Subject: Analysis of air sample from Mako 5415 compressor,
50 hour sample.

1. In accordance with your request, the air sample delivered to the gas analysis lab was analyzed and found to contain:

Component	Sample
Oxygen	21%
Nitrogen	78.1%
Argon	0.9%
Carbon Dioxide	372 PPM
Carbon Monoxide	9.4 PPM
Total Hydrocarbons*	1.6 PPM
Total Halogens**	<0.5 PPM
Methane	1.6 PPM
Acetylene	<0.1 PPM
Acetone	<0.1 PPM
Freon 113	<0.1 PPM
Methyl Ethyl Ketone	<0.1 PPM
Ethylene	<0.1 PPM
Toluene	<0.1 PPM
Benzene	<0.1 PPM
Formaldehyde	<0.1 PPM
C4+	<0.1 PPM

*Expressed as methane equivalents.

**Expressed as methyl chloride equivalents.

2. The above sample showed no appreciable contamination; all components were within the acceptable range of the U.S. Navy Diver's Air Purity Standards.

Glen Deason
Chemist

Memorandum

17 December 1991

To: Dave Sullivan, NEDU

From: Glen Deason, Code 5130

Subject: Analysis of air sample from Mako 5415 compressor purification system, 75 hr. test.

1. In accordance with your request, the air sample delivered to the gas analysis lab was analyzed and found to contain:

Component	Results
Oxygen	21%
Nitrogen	78.1%
Argon	0.9%
Carbon Dioxide	303 PPM
Carbon Monoxide	31.4 PPM
Total Hydrocarbons*	1.9 PPM
Total Halogens	<0.5 PPM
Methane	1.9 PPM
Ethane	<0.1 PPM
Acetone	<0.1 PPM
Acetylene	<0.1 PPM
Methyl Ethyl Ketone	<0.1 PPM
Freon 113	<0.1 PPM
Benzene	<0.1 PPM
Toluene	<0.1 PPM
C4+	<0.1 PPM

*Expressed as methane equivalents

2. The above sample showed appreciable contamination; all components were not within the acceptable range of the USN Diver's Air Purity Standards.

Glen Deason
Chemist

LEADING PARTICULARS

1.1 DESIGN DESIGNATION

Flange coupled motor driven machine.....5415
V-belt driven machine, electric or internal combustion powered.....5415

1.2 TECHNICAL DATA - GENERAL

Type.....Single acting, four stage, 90° Vee
Cooling.....Water
Direction of rotation viewed from drive end.....Anti-clockwise
Number of valves.....One combined suction and delivery per stage
Type of valve.....Flat plate, low lift
Mounting.....Three point, anti-vibration mounts
Lifting points.....Three

TEMPERATURES

Minimum ambient temperature.....0°C (32°F)
Maximum compressor air intake temperature.....45°C (114°F)
Maximum cooling air temperature (Radiator Sets).....30°C (86°F)
Maximum water inlet temperature.....37°C (99°F)
Temperature rise across machine.....10°C-12°C (18°F-22°F)

SPEEDS

Maximum speed.....1500 rev/min
Minimum speed.....725 rev/min

PRESSURES

Minimum working pressure.....140 bar (2030 lbf/in²)
Maximum working pressure.....350 bar (5000 lbf/in²)
Maximum water pressure.....5 bar.(75 lbf/in²)
Oil pressure.....2.6 bar (40 lbf/in²)

LUBRICATION

Crankcase oil capacity.....23 litres (40 U.K. pints)
Cylinder lubricator capacity.....1 litre (1.7 U.K. pints)
Cylinder lubricator feed rate (3 & 4 stages).....1 rev every 60 secs.± 10 sec
Recommended oil.....Shell Turbo T78
Recommended alternative oil.....Mobil Rarus 427
Recommended grease (for assembly).....Shell Alvania R3
Synthetic lubricants.....See: separate section

COOLING

Water.....Mains or water pump circulation
Cooling water flow rate @ 15°C(59°F).....75 l/h/Kw (12 g/h/bhp)

INTERNAL DIMENSIONS

Piston stroke.....55 mm (2.105")
First stage cylinder bore.....140 mm (5.512")
Second stage cylinder bore.....77 mm (2.76")
Third stage cylinder bore.....35 mm (1.38")
Fourth stage cylinder bore.....18 mm (0.709")

CONNECTIONS

First stage suction.....Special flange adaptor Rp 2 (2" bsp)
Fourth stage delivery.....Rp 1/2 (1/2" bsp)
Water inlet.....Rp 3/4 (3/4" bsp)
Water outlet.....Water outlet.....Rp 3/4 (3/4" bsp).....Rp 3/4

WATER TEST PRESSURES

First stage cooler.....7.6 bar (110 psig)
Second stage cooler.....42 bar (610 psig)
Third stage cooler.....200 bar (2900 psig)

Fourth stage cooler.....525 bar (7600 psig)

Water jacket.....7.6 bar (110 psig)

UNIT WEIGHT (Approx)

Bare machine.....520 Kgf (1140 lbs)

Flange mounted machine.....819 Kgf (1806 lbs)

Radiator set on bedplate.....983 Kgf (2168 lbs)

MAKO[®]

5000 SERIES Watercooled Performance 10-75 HP

MEDIUM PRESSURE 200 - 500 PSIG

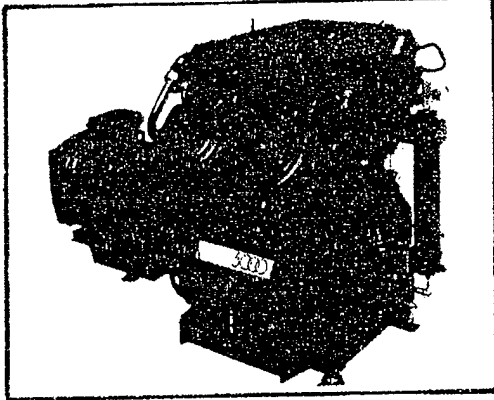

INTERMEDIATE PRESSURE 600 - 1235 PSIG

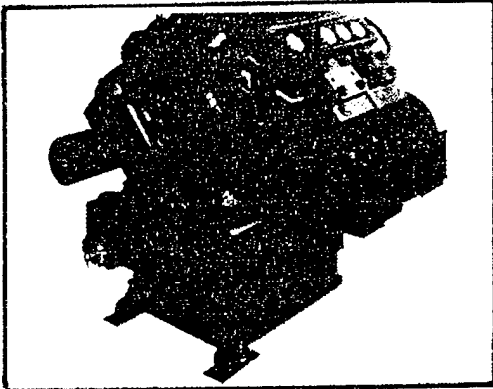

HIGH PRESSURE 2000 - 5000 PSIG

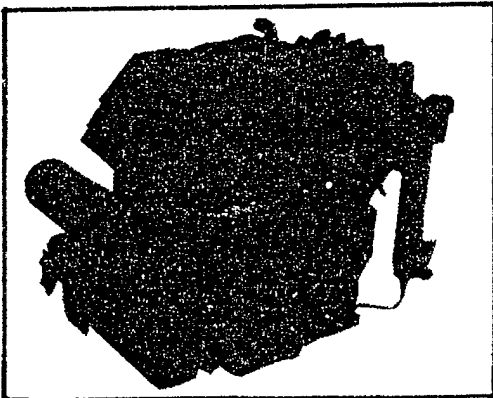

MODEL	HP	RPM	PSIG	FAD
5212	10	1184	500	21.6
	15	1435	500	26.8
	20	1742	500	33.3
5215	20	1184	500	45.1
	30	1742	500	66.6
5236	50	1184	500	116.5
	75	1742	500	170.3

5315	15	990	1235	19.6
	20	1435	1235	28.1
5336	40	990	1235	52.4
	50	1435	1235	75.2

5415	20	990	5000	18.9
	25	1184	5000	22.4
	30	1435	5000	27.1
5436	50	1184	5000	60.7
	60	1435	5000	73.6

We reserve the right to alter details and specifications without notice.