

REPORT DOCUMENTATION PAGE

Form Approved
OMB NO. 0704-0188

Public reporting burden for this collection of information is estimated to average 1 hour per response, including the time for reviewing instructions, searching existing data sources, gathering and maintaining the data needed, and completing and reviewing the collection of information. Send comment regarding this burden estimate or any other aspect of this collection of information, including suggestions for reducing this burden, to Washington Headquarters Services, Directorate for Information Operations and Reports, 1215 Jefferson Davis Highway, Suite 1204, Arlington, VA 22202-4302, and to the Office of Management and Budget, Paperwork Reduction Project (0704-0188), Washington, DC 20503.

1. AGENCY USE ONLY (Leave blank)	2. REPORT DATE March 29, 1996	3. REPORT TYPE AND DATES COVERED Final Report: 7/1/92-12/31/95	
4. TITLE AND SUBTITLE Cure and Water Monitoring in Selected Polymers		5. FUNDING NUMBERS DAAL03-92-G-0267	
6. AUTHOR(S) C.S.P. Sung and N.H. Sung		8. PERFORMING ORGANIZATION REPORT NUMBER	
7. PERFORMING ORGANIZATION NAME(S) AND ADDRESS(ES) Institute of Materials Science University of Connecticut 97 N. Eagleville Rd. Storrs, CT 06269-3136		10. SPONSORING / MONITORING AGENCY REPORT NUMBER ARO 20154.9-MS	
9. SPONSORING / MONITORING AGENCY NAME(S) AND ADDRESS(ES) U.S. Army Research Office P.O. Box 12211 Research Triangle Park, NC 27709-2211		11. SUPPLEMENTARY NOTES The views, opinions and/or findings contained in this report are those of the author(s) and should not be construed as an official Department of the Army position, policy or decision, unless so designated by other documentation.	
12a. DISTRIBUTION / AVAILABILITY STATEMENT Approved for public release; distribution unlimited.		12 b. DISTRIBUTION CODE 19960910 083	
13. ABSTRACT (Maximum 200 words) The objective of the research under this contract was to develop in-situ monitoring technique for cure and water in selected polymers. The techniques explored are <u>intrinsic</u> fluorescence, phosphorescence and UV reflection. The polymers studied are epoxy, polyimide and vinyl polymers (MMA and styrene). These techniques were also used to probe fiber/resin interphase. The intrinsic fluorescence spectral shift (25 nm) due to the cure of epoxy with the main curing agent, p,p'-diamino diphenyl sulfone (DDS) was related to the extent of cure and implemented by fiber-optic fluorimeter for in-situ cure characterization of epoxy/graphite composites. The phosphorescence lifetime due to DDS was found to be useful to measure the extent of cure in the prepregs. The external UV reflection technique was developed as an intrinsic cure monitoring technique for polymers such as polyimides exhibiting weak fluorescence. A bifurcated multifiber probe for UV reflection technique has been implemented for in-situ imidization studies. Polymerization of styrene and methyl methacrylate (MMA) were successfully monitored by UV and in-situ fluorescence techniques via fiber-optics. For water-uptake monitoring, the fluorescence intensity of DDS which shows sensitive decrease was correlated to the water-uptake measured by gravimetry in neat epoxy as well as in epoxy composites. The characterization of cure reactions in epoxy/fiber interphase has been probed by evanescent fluorescence due to an extrinsic cure sensor, p,p'-diamino azobenzene by using sapphire fiber due to its high refractive index of 1.78 in comparison to that of epoxy of 1.61.			
14. SUBJECT TERMS Cure characterization, Intrinsic Fluorescence, UV Reflection. Epoxy, Diamine Curing Agent, Polyimide, Water-Uptake, Imidization, In-situ Cure, Fiber-Optic Fluorimeter		15. NUMBER OF PAGES	
17. SECURITY CLASSIFICATION OF REPORT UNCLASSIFIED		16. PRICE CODE	
18. SECURITY CLASSIFICATION OF THIS PAGE UNCLASSIFIED		20. LIMITATION OF ABSTRACT UL	
19. SECURITY CLASSIFICATION OF ABSTRACT UNCLASSIFIED		21. LIMITATION OF ABSTRACT	

CURE AND WATER MONITORING IN
SELECTED POLYMERS

Final Report

C.S.P. Sung and N. H. Sung

March 29, 1996

U.S. Army Research Office
30154-MS
DAAL03-92-G-0267

Institute of Materials Science
University of Connecticut
97 N. Eagleville Rd.
Storrs, CT 06269-3136

and

Dept. of Chemical Engineering
Tufts University
4 Colby St.
Medford, MA 02155

Approved for Public Release
Distribution Unlimited

A. State of the Problem Studied

Characterization of cure extent for the composites containing epoxy or polyimide during and after the fabrication process is very important for reproducible process ability and achievement of the consistent mechanical properties.

Dielectrometry(1) and fiber-optic FT-IR(2) and Raman(3) techniques have been recently reported as cure monitoring methods. Each method has advantages and disadvantages. For example, dielectrometry seems to be insensitive after about 60% cure in epoxies(1). Fiber-optic FT-IR suffers from the lack of the transparent fibers in the full IR range. Scattered light due to fiber, decrease in epoxy peak and increasing fluorescence at later stages of cure can complicate fiber-optic Raman techniques(3).

During the last ten years, we have developed and applied sensitive UV and fluorescence techniques for in-situ characterization of cure and water-uptake in high temperature, high performance polymers and composites (4-12). Since optical fibers are usually transparent in UV and visible range, these techniques were successfully implemented for in-situ monitoring (5,9).

Our first approach was the route of the extrinsic fluorophoric sensors, which were added in small amount, either to mimic the curing agent or to act as water sensitive sensor. The extrinsic sensors are sometimes inconvenient to add, especially to prepregs composed of the slightly pre-cured resin and reinforcing fibers. Also, in some polymers containing fillers, the fluorescence signal from a small amount of the extrinsic sensor may be blocked due to the fillers and the other additives. Because of these undesirable aspects, we investigated the intrinsic fluorescence or UV signals that can be correlated to cure and water uptake during the last four years.

B. Summary of the Most Important Results

The intrinsic behavior of the main curing agent *p, p'*-diamino diphenyl sulfone (DDS) used in epoxy composites turned out to be very useful in the determination of cure extent, particularly in excitation spectra (8). It shows a progressive red shift of about 24 nm due to the conversion of the primary amine to the tertiary amine groups in DDS. Furthermore, the spectral shift is clearly related to the extent of DDS reaction and epoxide reaction as determined by the model compound studies as well as in a stoichiometric mixture of DDS and epoxide. This DDS excitation behavior was

successfully implemented for in-situ cure monitoring in the tetrafunctional epoxy based graphite prepreg containing BF_3 catalyst, which is the actual high performance composite system, by co.P.I.'s group at Tufts' university (9). Three different cure cycles, i.e., the isothermal, a constant heating rate and three stages of cure were studied to mimic the real cure conditions. In-situ data were reduced, by temperature correction for comparisons of each cure cycle. The optimum probe configuration was found to be "through-the-plate" mode, which is normal to the prepreg plies within the laminate assembly. DDS excitation data were correlated with the extent of epoxide reaction by FT IR, thus providing a complete information on both the extent of amine and epoxide reactions during cure. Furthermore, the spectral signal is easily obtained even in composites reinforced with graphite fibers, since the DDS concentration in the resin is high, and thus, even a thin coating is sufficient to generate a strong signal. Unlike the dielectrometry, our fluorescence technique is sensitive throughout the entire extent of cure.

The DDS excitation spectroscopy, while useful as an in-situ cure monitoring technique, does not have the sensitivity to detect small changes in the cure extent since the sensitivity is about 4% in the cure extent. The DDS phosphorescence which occurs at longer wavelengths than the fluorescence is found to exhibit more sensitive changes either in the spectral shift at 77°K or in the room temperature intensity changes (10). Even though the phosphorescence is not an in-situ technique, it can determine small changes in the cure extent, especially for prepregs, which could be exposed to different thermal conditions, in order to determine cure conditions, prior to the actual cure. Such a characterization is essential in optimizing cure conditions.

Due to high absorption in the UV transmission spectra, the external UV reflection technique (Figure 1 for the schematic of the experimental arrangement) has been developed as an intrinsic cure monitoring method to be applied to polymers such as polyimides which exhibit weak fluorescence. UV reflection spectra on epoxy-DDS showed similar red shifts as the excitation spectra. Both the reflection and the transmission UV spectra showed 24 nm shifts, which have been correlated to the extent of cure. After testing with epoxy-DDS, UV reflection was applied for the imidization study of polyamic acid made from phenylene diamine and a fluorinated dianhydride. This polyamic acid is the widely used matrix resin for the polyimide composites. The spectral deconvolution of the UV

reflection spectra such as Figure 2 based on the spectra of the polyamic acid and polyimide provides a way to determine the relative composition of polyamic acid and polyimide (11b).

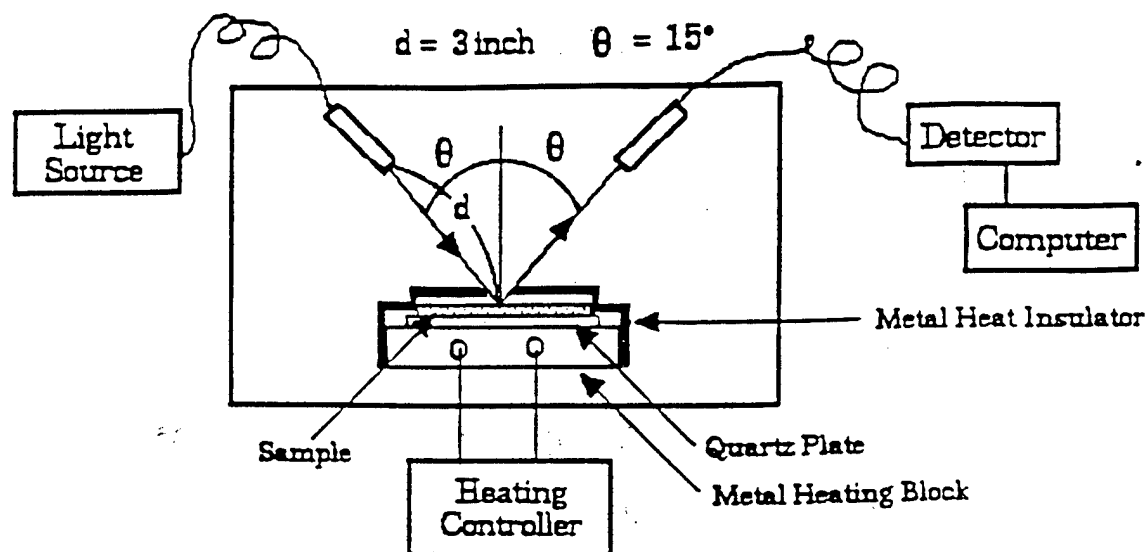

Figure 1. Schematic diagram of external reflection UV-Vis set up using fiber-optic instrument.

A UV reflection setup as shown in Figure 1 requires the exact positioning of optical fiber cables at $5 \sim 15^\circ$ from the vertical position. For practical in-situ applications, the design is difficult to implement. Therefore, we designed a new improved set-up. As shown in Figure 3, a bifurcated, multifiber (140 strands) probe for UV reflection measurements has been designed to be attached to the Perkin-Elmer Lambda 6 UV-Vis spectrometer by our Co. P. I's group at Tufts University. In this design, both excitation and the detection side of the optical fibers are combined into a single probe and placed vertically to the sample surface. Mathematical analysis has been carried out to illustrate the relationship between UV reflection intensity and the probe-sample distance. With the fiber's numerical aperture value of 0.20, the maximum reflection intensity is obtained when the probe sample distance is 1.7 mm. This setup was tested by monitoring cure of epoxy-DDS and imidization of polyamic acid. The spectral quality is comparable to the one obtained with external reflection accessory (13a).

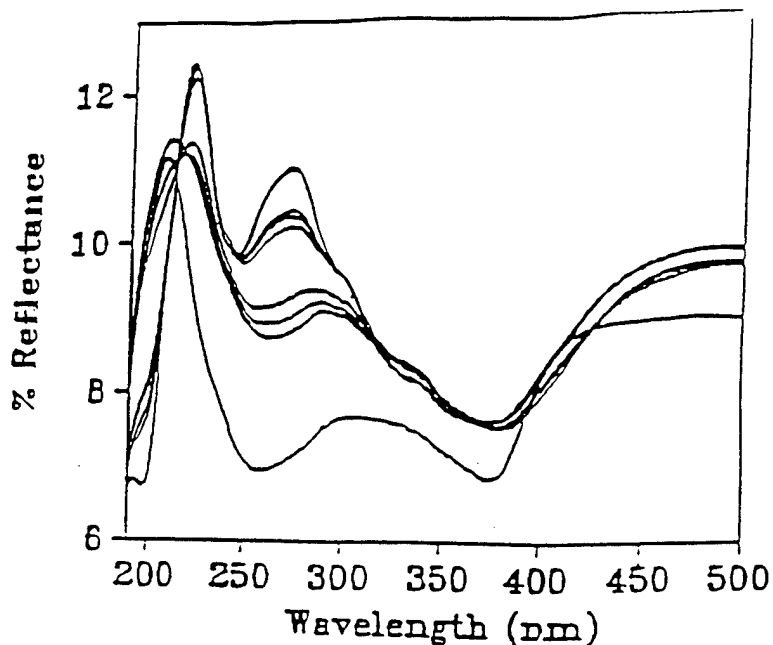

Figure 2. UV reflection spectra of polyamic acid (6FDA/PDA) film as a function of stepwise imidization (from bottom to top, 0 min, 10, 20, 30 min at 160°C, 10, 20, 30 min at 200°C, followed by 20 min at 250°C)

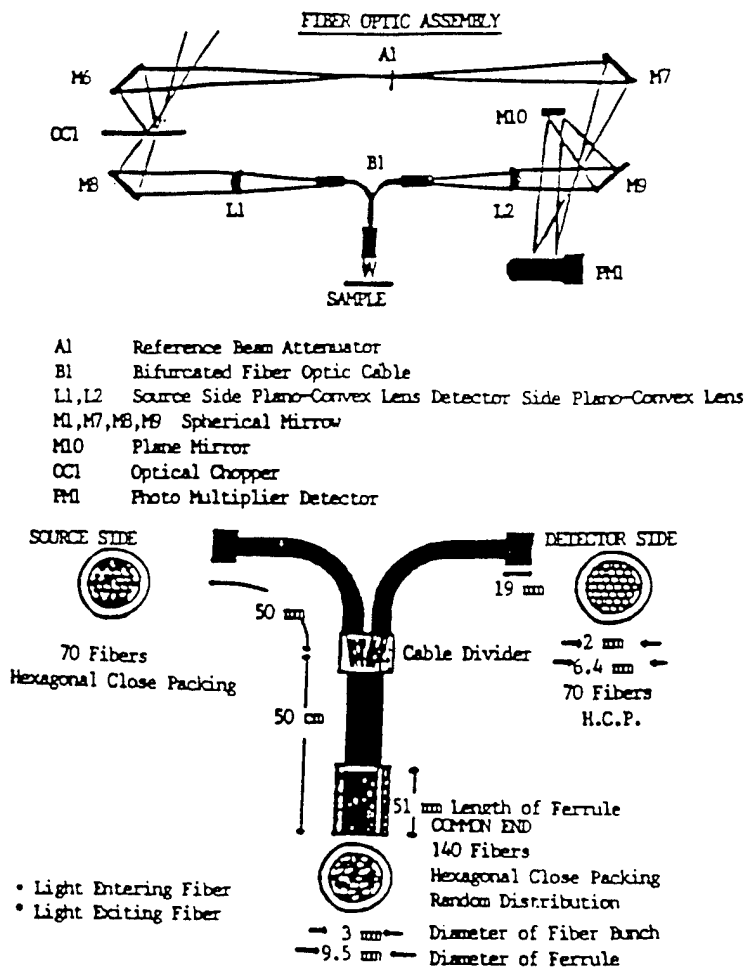

Figure 3. Schematic diagrams for fiberoptic UV reflection set-up bifurcated fiber configuration.

For water monitoring, the intrinsic signal of DDS has been further explored as a sensitive probe of water uptake. The fluorescence intensity of DDS was tested in solvents of varying polarity as well as the different form of DDS (primary DDS vs. tertiary DDS), to understand the effect of cure. Before cure as well as after cure, DDS signal is found to exhibit sensitive intensity decrease as function of water-uptake. Thermal analysis has been used to characterize the state of water and to correlate the depression of Tg with the fluorescence intensity.

For the water sorption studies, both neat epoxy of TGDDM/DDS and commercial grade glass fiber prepreg (Hexcel 120-38-f263) were studied at room temperature. Both excitation spectra (emitted at 440nm) and emission spectra (excited at 366nm) of the cured system show a substantial decrease in intensity of to 40%, upon moisture sorption in the matrix, of which equilibrium water uptake is only 4%. The % intensity drop gives almost a linear relationship with the % water-uptake data and this enables us to determine the moisture content in TGDDM/DDS epoxy from the % fluorescence intensity drop.

Polymerization of styrene and methyl methacrylate (MMA) were studied by UV and fluorescence spectroscopic techniques. Using a sharp decrease in the extinction coefficient at 250nm and the fluorescence quantum yield at 308nm of styrene following polymerization, styrene conversion in solution polymerization by UV and fluorescence measurements were found to correlate well with IR results monitoring the disappearance of vinyl groups, at three different temperatures (65, 70, and 75°C). The activation energy of about 6 kal/mole was obtained. Using the decrease in UV absorbance of MMA during polymerization, solution polymerization of MMA was studied and compared with IR results. Due to the solvent absorbance, UV method underestimates the conversion to a certain extent. When a small amount of styrene is added in MMA polymerization as a reactive extrinsic comonomer, the conversion of styrene measured by fluorescence is found to be faster than MMA, due to the characteristic reactivity ratios of MMA and styrene. The correlation curve could be used to estimate MMA conversion from styrene fluorescence, providing a method more sensitive than the viscosity-dependent fluorescence. Due to self-quenching, little fluorescence of styrene is observed up to 75% conversion, but increases sharply from 75% to 85% conversion, followed by a drastic decrease during the last 15% conversion. In comparison to other methods of following vinyl

polymerization such as refractive index, density and GPC, these spectroscopic techniques provide real-time-in-situ capability as well as better sensitivity, especially in the later stages of polymerization.

Evanescent wave probing of epoxy/amine reactions at the fiber/matrix interface has been successfully carried out by the extrinsic fluorescence technique using extrinsic fluorescence fluorophore (DAA) and SRH as the internal reference dye, by using sapphire fiber due to its high refractive index (1.75). Due to the inherently low signals associated with evanescent wave sensing, the signal was maximized by several methods including: metallizing the sapphire fiber tip, use of a dichroic mirror, and selection of proper sapphire diameter. The probe sapphire fiber was connected to the fluorimeter via $660\mu\text{m}$ silica optical fiber which was drawn down to $450\mu\text{m}$ to match the sapphire diameter. Evanescent wave sensing of the epoxy/sapphire interphase is compared with those from the distal end fiber data. The evanescent data appear to exhibit slightly faster reaction rate and lower final extent of amine reaction than the distal end data, suggesting that there may be some surface effect on the cure reaction at the glass fiber/epoxy interphase. Currently, probe fiber surface is modified by organosilane or plasma, and its effect on cure reaction is investigated.

c. List of all Publications and Technical Reports

1. B. Grundun, Y.S. Kim and C.S.P. Sung, "Cure Monitoring of Styrene Containing Polymers Using UV-Reflection and Fluorescence Spectroscopies", ACS Polymer Preprint, 37(1), 477, 1996.
2. S.K. Wang and C.S.P. Sung, "Cure Monitoring of Bulk MDI - Based Polyurea Polyurethane by In-situ Emmission Fluorescence", ACS Polymer Preprint, 37(1), 467, 1996.
3. X.D. Sun and C.S.P. Sung, "Cure Characterization in Model Urethane Reaction and Polyurethane by Intrinsic Fluorescence Technique", Macromolecules, 29, 3198, 1996.
4. C.S.P. Sung and N.H. Sung, "UV and Fluorescence Techniques for Characterization of Cure Processes in Polymers and Composites", SAMPE Proceedings, 51, May, 1995, Anaheim, Ca.
5. Y.S. Kim, and C.S.P. Sung, "Microenvironments at Specific Chain Sites in Atactic Polystyrene Gels Studied by Photoisomerization", Macromolecules, 29, 462, 1996.
6. H.J. Paik, D.K. Hestermann and N.H. Sung, "UV Reflection Spectroscopy for In-Situ Polymer Reaction Monitoring using Bifurcated Optical Fiber", 2816 SPE Proceedings, May, 1995. Boston, Ma.
7. A. Fuchs and N.H. Sung, "Composite Interphase Study by Evanescent Fiberoptic Fluorescence", SPE Proceedings, 2437 May, 1995 Boston, Ma.
8. Xu, Y.E. and C.S.P. Sung, "Cure Characterization of Bisphenol A Dicyanate by Fluorescence, UV and FTIR Spectroscopy", ACS Polymer Preprint, 36-2, 356, 1995.
9. Kim, Y.S., C.S.P. Sung and Y.H. Kim, "Microenvironment at Specific Chain Sites Studied by Photoisomerization and Computer Simulation in Polystyrene Solutions", Macromolecules, 28, 6198, 1995.
10. Song, J.C. and C.S.P. Sung, "Room Temperature Phosphorescence Studies of Epoxy Resin Cured by an Aromatic Diamine", Macromolecules, 28, 5581, 1995.
11. Yu, J.W. and C.S.P. Sung, "Cure Characterization in Diamine Cured Epoxy and Polyimide by UV Reflection Spectroscopy", Macromolecules, 28, 2506, 1995.
12. Kim, Y.S. and C.S.P. Sung, "UV and Fluorescence Characterization of Styrene and Methyl Methacrylate Polymerization", J. Appl. Polym. Sci., 57, 363, 1995.
13. Sung, C.S.P. and N.H. Sung, "UV and Emission Techniques for Characterization of Polymers and Composites", ACS Polym. Mat. Sci. and Eng. Proceedings, 71, 69, 1994.

14. Phelan, J.C. and C.S.P. Sung, "Cure Characterization of a Bismaleimide Diallyl Bisphenol-A Resin by Fluorescence, UV and FTIR Spectroscopy", ACS Polymer Mat. Sci. Eng. Proceedings, 71, 425, 1994.
15. Sun, X.D. and C.S.P. Sung, "Intrinsic Fluorescence Cure Sensor for Reaction Monitoring in Polyurethane", ACS Polymer Preprints, 35-1, 435, 1994.
16. Yu, J.W. and C.S.P. Sung, "UV Reflection and Fluorescence for Imidization Study", ACS Polymer Preprints, 35-1, 811, 1994.
17. Kim, Y.S. and C.S.P. Sung, "UV and Fluorescence Studies for Vinyl Polymerization", ACS Polymer Preprints, 35-1, 439, 1994.
18. Kim, Y.S., C.S.P. Sung, Y.H. Kim and A. Glynn, "Mobility Measurement and Computer Simulation at Specific Sites in Polystyrene Solutions and Gels", ACS Polymer Preprints, 35-1, 161, 1994.
19. Paik, H.J. and N.H. Sung, "In-Situ Characterization of Tetrafunctional Epoxy and Composites via Fiberoptic Fluorescence", ACS PMSE Proceedings, 71, 342, 1994.
20. W. Dang and N.H. Sung, "In Situ Cure Monitoring of Diamine Cured Epoxy by Fiberoptic Fluorimetry using Extrinsic Reactive Fluorophore", Polym. Eng. & Sci., 34, 707, 1994.
21. H.J. Paik and N.H. Sung, "Fiberoptic Intrinsic Fluorescence for In Situ Cure Monitoring of Amine Cured Epoxy Composites", Polym. Eng. and Sci., 34, 1025, 1994.
22. Song, J.C. and C.S.P. Sung, "Fluorescence Studies of Diaminodiphenylsulfone Curing Agent for Epoxy Cure Characterization", Macromolecules, 26, 4818, 1993.
23. Jen, G., S.J. Huang and C.S.P. Sung, "Characterization of the One Step Polyimide Synthesis", ACS Proceedings of Polymer Materials Sci. and Eng., 69, 453, 1993.
24. Sun, X.D. and C.S.P. Sung, "Intrinsic Fluorescence of Curing Agent for Water-Uptake Monitoring in Epoxy Network", ACS Polymer Preprints, 34-2, 548, 1993.

D. List of All Participating Scientific Personnel with their Degrees

A Fuchs	(PhD, 1995) Tufts	J. Phelan	(MS, 1995) UConn
D. Hestermann	(MS, 1996) Tufts	J.C. Song	(PhD, 1993) UConn
M. Kailani	(PhD, 1993) UConn	D.W. Sohn	(PhD, 1993) Tufts
Y.S. Kim	(PhD, 1993) UConn	X.D. Sun	(PhD, 1994) UConn
H.J. Paik	(PhD, 1995) Tufts	J.W. Yu	(PhD, 1994) UConn

5. Report of Inventions: None

6. Bibliography

1. (a) J. Jow, M.C. Hawley, M. Finzel and T. Kern, *Polym. Eng. & Sci.*, 28, 1450, 1988
(b) E. Marand, K.R. Baker and J.D. Graybeal, *Macromolecules*, 25, 2243, 1992
2. M.A. Druy, L. Elandigian and W.A. Stevenson, *SPIE Proceedings*, 986, 130, 1989
3. M.L. Myrick, S.M. Angel, R.E. Lyon and T.M. Vess, *SAMPE J.*, 28, 37, 1992
4. (a) C.S.P. Sung, E. Pyun and H.-L. Sun, *Macromolecules*, 19, 2922, 1986.
(b) W.C. Yu and C.S.P. Sung, *Macromolecules*, 23, 386, 1990.
(c) E. Pyun and C.S.P. Sung, *Macromolecules*, 24, 855, 1991.
5. (a) W. Dang, N.H. Sung and C.S.P. Sung, *ACS Polym. Mat. Sci. & Eng. Proceedings*, 63, 512, 1990.
(b) N.H. Sung, W. Dang, H.J. Paik and C.S.P. Sung, *SAMPE Proceedings*, 36, 1461, 1991, San Diego, CA.
(c) W. Dang and N. H. Sung, *Polym. Eng. Sci.*, 34,707, 1994.
6. (a) M.H. Kailani, C.S.P. Sung and S.J. Huang, *Macromolecules*, 25, 3751, 1992.
(b) P. Dickinson and C.S.P. Sung, *Macromolecules*, 25, 3758, 1992.
7. J.K. Yoo, S.D. Sun and C.S.P. Sung, *ACS Polymer Preprints*, 32-2, 364, 1991.
8. J.C. Song and C.S.P. Sung, *Macromolecules*, 26, 4818, 1993.
9. (a) H.J. Paik, N.H. Sung and C.S.P. Sung, *ACS Polym. Preprints*, 32-2, 669, 1991.
(b) H.J. Paik and N.H. Sung, *Polym. Eng. and Sci.*, 34, 1025, 1994.
10. J.C. Song and C.S.P. Sung, *ACS Polym. Mat. Sci. and Eng. Proceedings*, 67, 497, 1992.
11. (a) J.W. Yu and C.S.P. Sung, *ACS Polym. Preprints*, 35-1, 811, 1994.
(b) J.W. Yu and C.S.P. Sung, *Macromolecules*, 28, 2506, 1995
12. (a) X.D. Sun and C.S.P. Sung, *ACS Polym. Preprints*, 35-1, 435, 1994.
(b) X.D. Sun, "Luminescence Sensors for Water Uptake in Epoxy Networks and Cure Monitoring in Polyurethane", Ph.D. Thesis, University of Connecticut, 1994.