

REPORT DOCUMENTATION PAGE

Form Approved
OMB NO. 0704-0188

Public reporting burden for this collection of information is estimated to average 1 hour per response, including the time for reviewing instructions, searching existing data sources, gathering and maintaining the data needed, and completing and reviewing the collection of information. Send comment regarding this burden estimate or any other aspect of this collection of information, including suggestions for reducing this burden, to Washington Headquarters Service, Directorate for Information Operations and Reports, 1215 Jefferson Davis Highway, Suite 1204, Arlington, VA 22202-4302, and to the Office of Management and Budget, Paperwork Reduction Project (0704-0188), Washington, DC 20503.

1. AGENCY USE ONLY (Leave blank)

2. REPORT DATE
Oct 953. REPORT TYPE AND DATES COVERED
Final 15 Jun 90- 15 Dec 94

4. TITLE AND SUBTITLE

Formation of Transition Element Nitride Coatings
on Steels Using Elevated-Temperature PSII

5. FUNDING NUMBERS

DAAL03-90-G-0124

6. AUTHOR(S)

John R. Conrad

7. PERFORMING ORGANIZATION NAME(S) AND ADDRESS(ES)

Univ. of Wisconsin
Madison, WI 53706-1687

19960912 104

9. SPONSORING / MONITORING AGENCY NAME(S) AND ADDRESS(ES)

U.S. Army Research Office
P.O. Box 12211
Research Triangle Park, NC 27709-221110. SPONSORING / MONITORING
AGENCY REPORT NUMBER

ARO 27552.16-MS

11. SUPPLEMENTARY NOTES

The views, opinions and/or findings contained in this report are those of the author(s) and should not be construed as an official Department of the Army position, policy or decision, unless so designated by other documentation.

12a. DISTRIBUTION / AVAILABILITY STATEMENT

Approved for public release; distribution unlimited.

12 b. DISTRIBUTION CODE

DTIC QUALITY INSURED

13. ABSTRACT (Maximum 200 words)

Under the auspices of the U.S. Army grant, we have made considerable strides in all aspects of PSII technology. We have developed a fundamental understanding of plasma physics issues such as sheath propagation, secondary electron emission and heat transfer in targets. These studies have a direct relevance to practical issues such as dose uniformity and batch processing feasibility of PSII. To monitor the ion species and thier interactions in-situ we have designed and developed a electric field analyzer and are currently installing a LIF system. We have developed a RF plasma source for the long IBED runs required to produce thick coatings. We have successfully deposited transition

(see SF298 continuation sheet)

14. SUBJECT TERMS

15. NUMBER OF PAGES

16. PRICE CODE

17. SECURITY CLASSIFICATION
OF REPORT

UNCLASSIFIED

18. SECURITY CLASSIFICATION
OF THIS PAGE

UNCLASSIFIED

19. SECURITY CLASSIFICATION
OF ABSTRACT

UNCLASSIFIED

20. LIMITATION OF ABSTRACT

UL

REPORT DOCUMENTATION PAGE (SF298)
(Continuation Sheet)

metal nitride coatings and conducted microstructural and properties evaluation using a wide range of analytical techniques. We have designed and built a fretting wear and scratch tester to evaluate the IBED coatings. Throughout this investigation, we have focused on the applicability of PSII coatings to 'real world' defense applications. In this regard we have forged collaborations with a number of institutions of the U.S. Army. This interaction has led to a number of two-way visits as well as PSII treatment and field testing of a variety of parts and components that are of relevance to US Army. In the following section we detail in discrete sections. the various investigations that were conducted under the auspices of the Phase I of the U.S. Army grant.

TITLE

Formation of Transition Element Nitride Coatings on Steels Using Elevated
Temperature PSII

TYPE OF REPORT (TECHNICAL, FINAL PROGRESS)

Final

AUTHOR(S)

Prof. John R. Conrad

DATE

May 9, 1996

U.S. ARMY RESEARCH OFFICE

CONTRACT/GRANT NUMBER

DAAL03-90-G-0124

INSTITUTION

University of Wisconsin

APPROVED FOR PUBLIC RELEASE;

DISTRIBUTION UNLIMITED.

**THE VIEWS, OPINIONS, AND/OR FINDINGS CONTAINED IN THIS REPORT ARE
THOSE OF THE AUTHOR(S) AND SHOULD NOT BE CONSTRUED AS AN OFFICIAL
DEPARTMENT OF THE ARMY POSITION, POLICY, OR DECISION, UNLESS SO
DESIGNATED BY OTHER DOCUMENTATION.**

TABLE OF CONTENTS

Report Documentaion Page
Report Documenation Page (cont.)
Title Page
Memorandum of Transmittal

TABLE OF CONTENTS.....	1
A. STATEMENT OF THE PROBLEM.....	2
B. SUMMMARY OF MOST IMPORTANT RESULTS.....	3
B.1 Sheath Propagation Studies.....	3
B.2 Measurement of Secondary Electron Emission Coefficient.....	3
B.3 Plasma Physics of Planar Targets.....	4
B.4 Plasma Diagnostics.....	5
B.5 Transport And MIXing from Ion Irradiation (TAMIX) Model.....	6
B.6 Heat Transfer Predictions in PSII.....	7
B.7 Design of Radio Frequency (RF) Plasma Source for IBED.....	8
B.8 Tempering Studies of AISI 52100 Bearing Steel.....	10
B.9 Elevated Temperature Nitrogen Ion Implantation.....	10
B.10 Deposition of Titanium Nitride Films on AISI 52100 Bearing Steel.....	11
B.11 Deposition of Chromium Nitride Films on AISI 52100 Bearing Steel..	12
B.12 IBED of Chromium-Molybdenum Alloy.....	14
B.13 IBED of CrN on Computer Hard Discs.....	17
B.14 Instrument Development.....	19
B.15 Technology Transfer Activities with Defense & Defense Related Institutions.....	20
B.16 First International Workshop on Plasma-based Ion Implantation.....	28
B.17 Third Generation PSII System.....	29
C. PUBLICATIONS ACCRUING FROM THE GRANT (attached).....	30
D. PARTICIPATING SCIENTIFIC PERSONNEL SUPPORTED BY THE PROJECT.....	33

A. STATEMENT OF THE PROBLEM

The present work focuses on research and development of the Plasma Source Ion Implantation (PSII), a non-line-of-sight ion surface modification technique, that has shown considerable promise to improve wear and corrosion of materials. In PSII, targets to be implanted are placed directly in a plasma source and are then pulse biased to a high negative potential. Ions bombard from all sides simultaneously without the necessity of target manipulation. It is thus possible, by using PSII, to both treat large parts uniformly and to batch-process a large number of smaller parts simultaneously. Another significant advantage of PSII is that it offers an environmentally clean alternative to wet chemical bath electroplating procedures.

During the course of the present work, we have made significant strides in all facets of PSII technology. In the area of process development, we have significantly enhanced our knowledge of plasma physics of PSII. Here, issues such as sheath propagation and secondary electron emission have been investigated which influence dose uniformity, target heating and batch-processing feasibility in PSII. A Radio Frequency (RF) plasma source has been developed to produce thicker IBED coatings. In-situ diagnostics in PSII is difficult due to high vacuum levels and voltages that are involved. We have used Laser-Induced-Fluorescence (LIF) diagnostic to understand ion species interactions and a ExB system for the determination of ion species ratios. A Monte-Carlo code TAMIX has been developed to predict ion-substrate interactions and sputtering effects. The microstructure and properties of these coatings have been characterized using a wide range of experimental facilities. It has been demonstrated that PSII has the potential to improve their wear and corrosion resistance of materials. Collaborations and technology transfer activities have been established with a number of U.S. Army laboratories and related institutions.

It is clear from the work described in the above section that we have established a groundwork for successfully producing transition metal nitride coatings using the PSII technology. The unified approach involving plasma physics, diagnostics for process control, microstructural analysis and properties evaluation of coatings and eventually the industrial applications of these coatings, has provided us the basis for producing technologically useful coatings. The results of these studies have opened doors to other exciting avenues for research to further understand the processing parameters that govern the evolution of the coating microstructure. An understanding of this interaction will enable us to further improve the properties of the coatings and identify more potential applications where wear and corrosion are major concerns.

B. SUMMARY OF THE MOST IMPORTANT RESULTS

B.1 Sheath Propagation Studies

Upon the application of a negative bias, a plasma sheath forms around the target. The propagation of the sheath determines the rate of current collection and dose uniformity of the target. A model has been developed for the dynamic sheath which forms during the high voltage pulse. This model predicts the variation of the sheath edge position with time as well as the current collected by the target. A comparison of the predictions of this model to our experimental measurements of the position of the sheath edge obtained by using a Langmuir probe is shown in Fig. 1. The theory agrees quite well with experiment for both cylindrical and spherical targets.

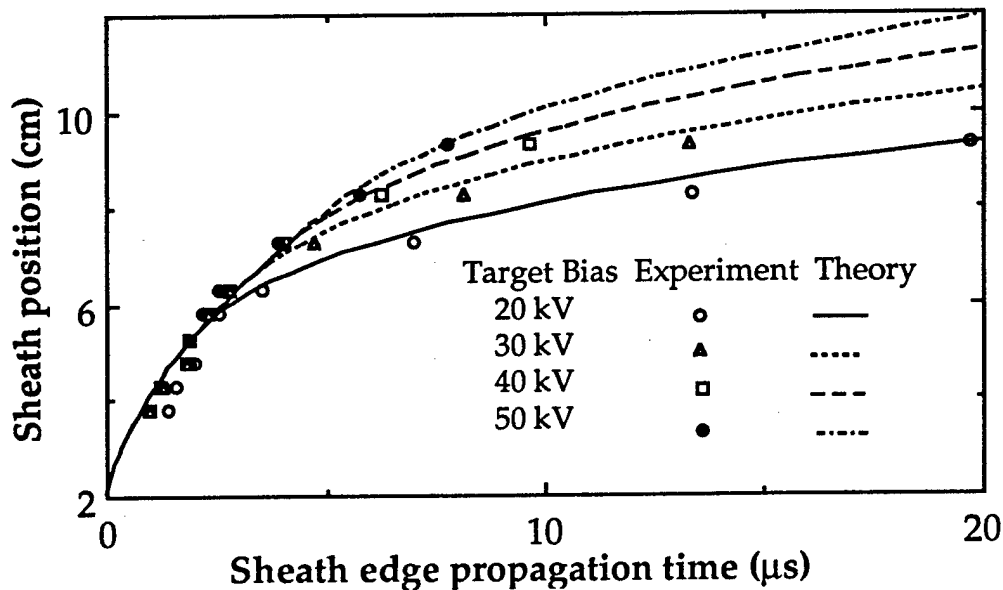

Fig. 1. Comparison of experimental measurements and theoretical predictions of sheath propagation for four different target biases on a spherical stainless steel target.

B.2 Measurement of Secondary Electron Emission Coefficient

Accurate assessment of ion dose is crucial for achieving the desired property improvements in engineering materials. During implantation of energetic ions, emission of secondary electrons from the surface of the material occurs. To determine the appropriate ion dose to the target in PSII, the knowledge of the secondary electron emission from the target is critical. We have developed an experimental procedure to measure the secondary electron emission coefficient, γ , which is the average number of electrons emitted per

incident ion. Since PSII is an inherently multi-energetic process we have determined the secondary electron emission coefficient for a range of ion energies. Spherical targets of copper, stainless steel, graphite, Ti-6Al-4V alloy and 6061 aluminum alloy were biased negatively to 20, 30 and 40 kV in argon and nitrogen plasmas. A Langmuir probe was used to detect the propagating sheath edge and a Rogowski transformer was used to measure the current to the target. Fig. 2 shows a sample graph of the propagating sheath edge.

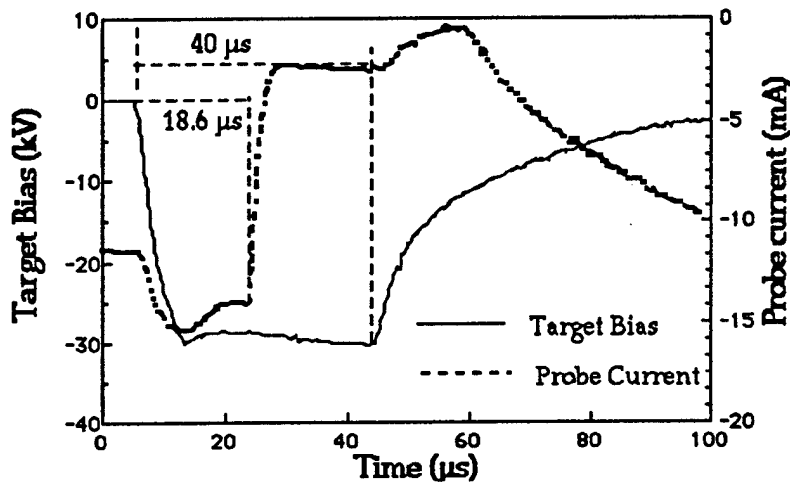

Fig. 2. A Langmuir probe trace used to measure the sheath propagation for a planar target.

B.3 Plasma Physics of Planar Targets

We have investigated the dose uniformity and sheath evolution around planar targets. The propagating sheath edge emanates initially as an ellipsoid elongated along the plane of the target, then transforms to a spherical shape at about one diameter away from the target, and ultimately the sheath becomes stationary at a distance. This phenomenon is illustrated in Fig. 3. To complement these sheath expansion measurements, silicon wafers were implanted with nitrogen to determine the spatial variations in implanted ion concentrations and the sputtering of the target material. Ex-situ measurements showed enhanced sputtering and shallower implantation at the edge of the wafer, relative to the center, in qualitative agreement with the sheath expansion measurements.

(continued)

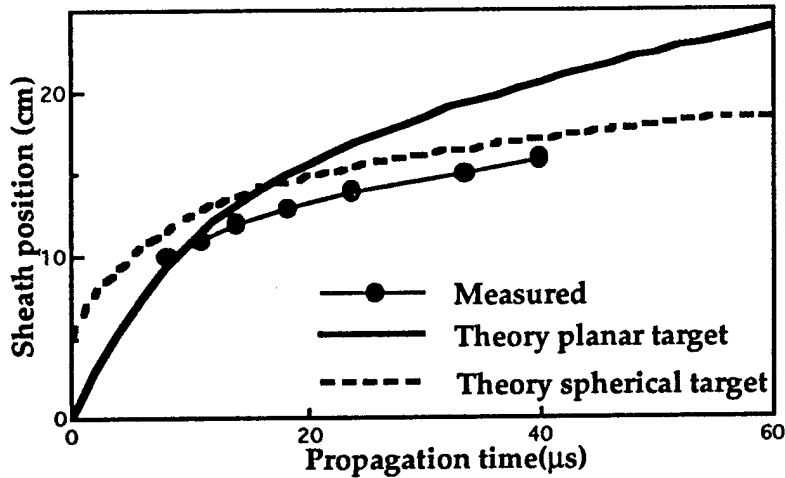

Fig. 3. Comparison of measured sheath propagation for a planar target with numerical calculations for planar and spherical targets.

B.4 Plasma Diagnostics

A knowledge of ion species and their ratios during PSII processing is critical in predicting the implantation dose and the effectiveness of the PSII process for a given application. For example, in nitrogen ion implantation, if the ion species mixture is 75% N_2^+ and 25% N^+ , then the number of atoms implanted per ion is 1.75. Ion species and their ratios depend on the parameters of the gaseous plasma. We have developed a diagnostic to quantify the ion species in the plasma. In this technique a mixed ion beam is extracted through the sampling source from the plasma. The extracted beam enters electric and magnetic fields, where, depending upon the charge and mass, ions are physically separated. By changing the electric field, different ion species can be analyzed. Undelected ions are recorded by a Faraday cup. Advantages of this technique are small unit size, simplicity, cost effectiveness and its capability of monitoring ion species in-situ during the PSII process. A typical application of this technique for a nitrogen plasma is shown in Fig. 4.

(continued)

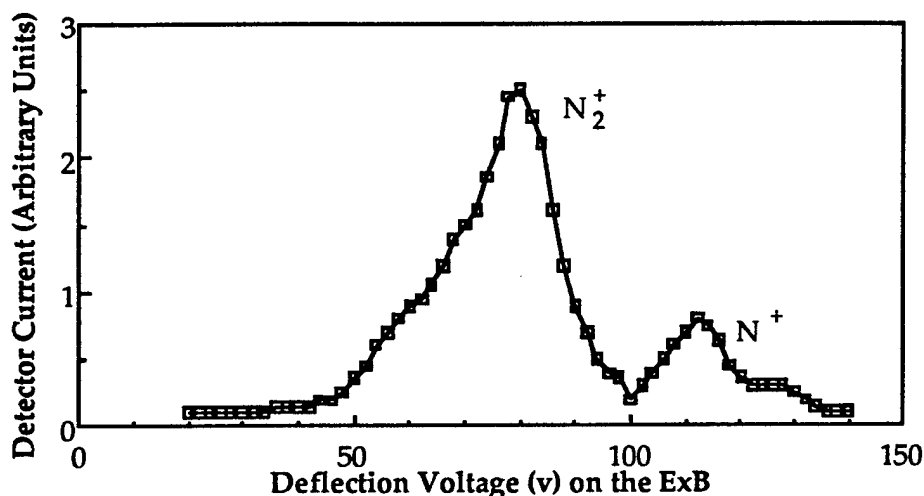

Fig. 4. Ion mass spectra in a nitrogen plasma under certain processing conditions: $N_2^+=75.7\%$ and $N^+=24.2\%$ have been measured in this case.

B.5 Transport And MIXing from Ion Irradiation (TAMIX) Model

A versatile Monte Carlo program, TAMIX, has been developed to simulate the complicated nature of the ion beam mixing process. TAMIX can be run in three modes; (i) static mode, where target composition is assumed to remain unchanged, and low fluence and damage distributions can be calculated, (ii) collisional-dynamic mode for high fluence and low target temperature cases and (iii) collisional-diffusional-dynamic mode in situations where target temperature is high and diffusional processes (radiation-enhanced diffusion and radiation-induced segregation) are activated in addition to collisional processes.

An example of the use of TAMIX for PSII-IBED is the determination of process parameters for coating CrN layers on computer hard discs. In this case a 400\AA Cr layer was first pre-sputtered on the hard disc and the goal was to implant nitrogen to produce a hard chromium nitride containing layer on the surface. TAMIX simulations for doses of 1×10^{17} , 2×10^{17} and 3×10^{17} ions/cm² of nitrogen implanted into Cr at a target bias of 8 kV are shown in Fig. 5. As expected, higher doses result in a greater nitrogen concentration at the surface but the total depth of the implanted layer does not differ for the three doses tested. However, TAMIX predictions show that the surface recession for doses of 1×10^{17} , 2×10^{17} and 3×10^{17} ions/cm² are 110, 190 and 270 \AA , respectively. Since this surface recession is a substantial fraction of the sputtered Cr layer thickness, a dose of 2×10^{17} ions/cm² was selected from the standpoint of maximizing the nitrogen concentration and minimizing Cr sputtering.

(continued)

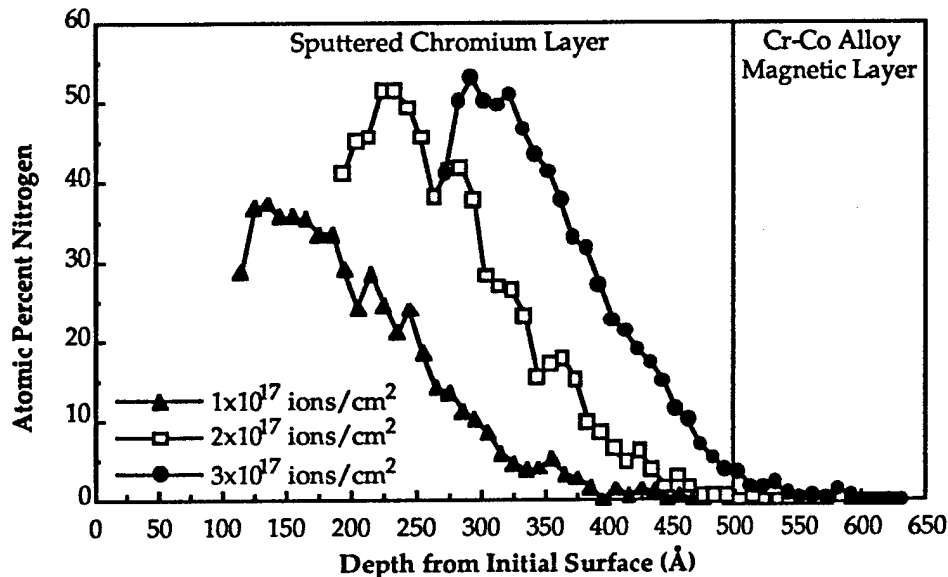

Fig. 5. TAMIX simulation showing the nitrogen concentration profiles in Cr for various implantation doses (target bias: 8kV).

B.6 Heat Transfer Predictions in PSII

As targets are treated using PSII, they are heated by the implanted ions. In some cases this is beneficial, as the heating leads to enhanced diffusion rates and correspondingly thicker surface modified layers. In other cases, though, heating is not desirable, as in the case of materials prone to overaging or tempering. Hence, the ability to predict the temperature of targets in the PSII chamber is crucial.

An effort has been made to achieve this goal using a lumped-capacitance heat transfer model. The targets are assumed to be heated by the energetic ions and cooled by both radiation to the plasma chamber and conduction down the support stalk to the base of the chamber. This leads to a first order differential equation which can be integrated numerically to provide the target temperature as a function of time for a given target geometry and for given plasma parameters.

There are two important quantities in this model which are not well known and produce uncertainties in the results. These are the emissivity and the ion power that strikes the target. The emissivity can be measured by measuring the cooling rate of a target after implantation and comparing the results to predictions by the thermal model described above. Adjusting the emissivity in the model until sufficient agreement between the model and the measured

cooling curve is achieved, provides an estimate of the target emissivity. The ion power is determined by the ion current and voltage, but the current is not directly measured. Instead we measure a total current which includes an electron current that consists of secondary electrons emitted from the target. Hence, the ion power to the target is determined by taking the power calculated using the total current and dividing by $(1+\gamma)$, where γ is the secondary emission coefficient. Our efforts to measure γ were described earlier.

To test the model, four small (2.54 cm square by 0.16 cm thick) Ti-6Al-4V samples were placed on a larger (6.8 cm radius by 0.22 cm thick) base of the same material and implanted with ions having an average energy of 25 kV to a fluence of 5×10^{17} ions/cm². The target temperatures were measured during both heating and cooling using a Luxtron device and the results were compared to the model predictions. As shown in Fig. 6, the agreement is quite favorable. Hence, it appears this model can be used to predict target temperatures in the PSII chamber.

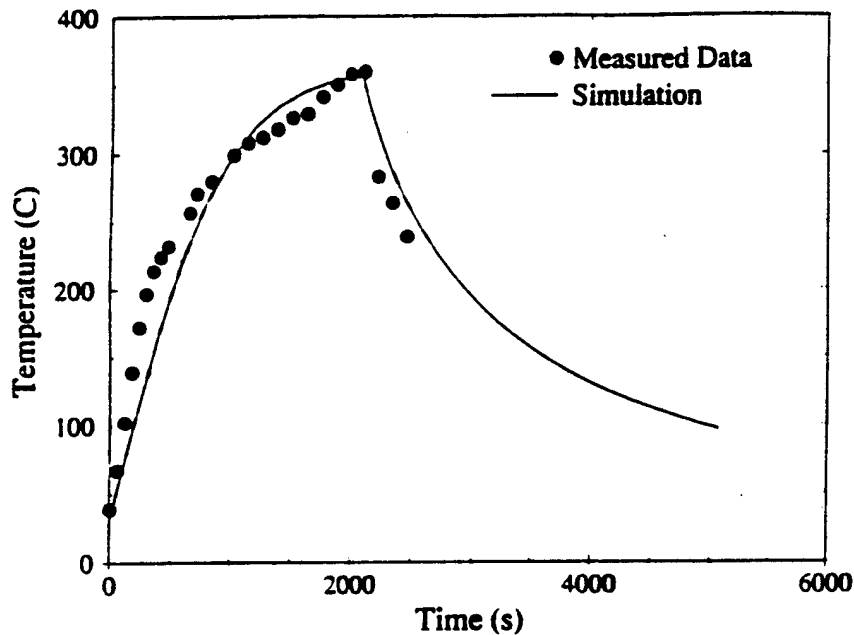

Fig. 6. Comparison between experimentally determined and theoretically modeled heat transfer predictions in PSII.

B.7 Design of Radio Frequency (RF) Plasma Source for IBED

The plasma in the PSII chamber is generated using tungsten filaments. However, the tungsten filaments used for the production of the primary electrons have short lives and are somewhat unsuitable for long runs that are required for producing thick IBED films.

Use of a RF power source offers an alternative route for plasma generation. A RF source can be coupled inductively or capacitively through a matching network to the vacuum chamber to produce the plasma. The parallel plate RF plasma is a well known method in industrial applications. RF is capable of sputtering dielectric materials because of self-bias formation at the cathode. We have fabricated a matching network for RF power supply for parallel plate sputtering and plasma generation. For example, a mixture of nitrogen and argon gas and chromium plated sputtering source were used to successfully produce stoichiometric CrN films on 52100 bearing steel. An illustration of the design of the RF source for PSII-IBED processing is shown in Fig. 7.

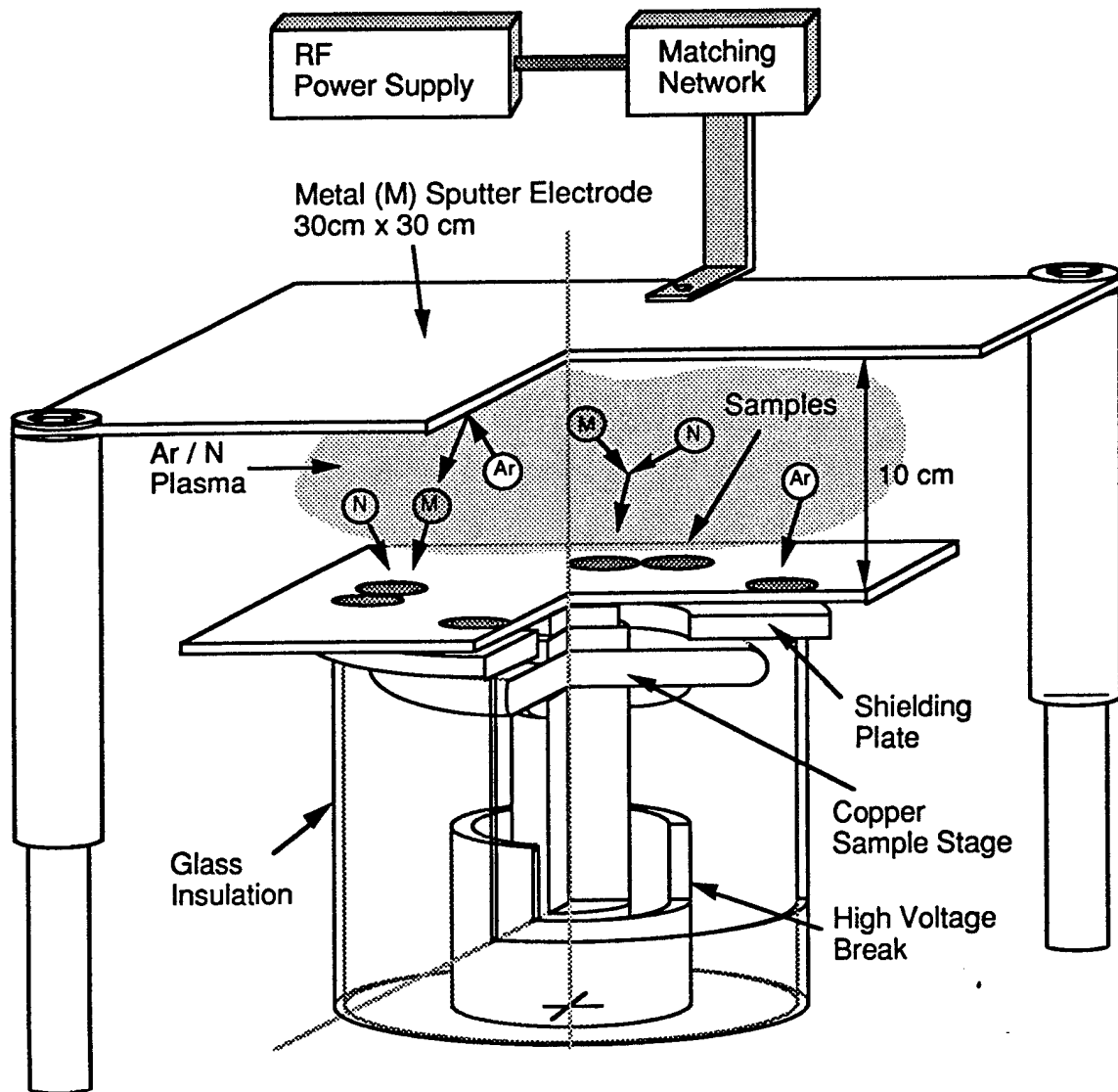

Fig. 7. A schematic illustration of the RF source designed for producing PSII-IBED coatings.

B.8 Tempering Studies of AISI 52100 Bearing Steel

Since AISI 52100 bearing steel was the proposed substrate material we have performed a detailed study of the tempering characteristics of this steel. The variation in the hardness of 52100 bearing steel (in fully martensitic condition) upon tempering in the temperature range 250°C to 650°C (heat treatment done in salt baths, accuracy $\pm 5^\circ\text{C}$) for time periods 1 and 3 hours were investigated.

The objective of this study was to enable the optimization of processing temperature with respect to the 52100 substrate microstructure during PSII-IBED processing. Three types of hardness measurements were made, each serving a different purpose. The Rockwell hardness (Rc) test produces the largest indentation depth and is capable of detecting any softening of the base material. In the Vickers Hardness (Hv) test (1000 gram load) the indentation depth is almost one tenth of the Rc test and therefore it is relatively insensitive to the presence of an implanted layer or IBED film, but can detect near surface softening from temperature rise. In the Knoop hardness (H_k) test (50 gram load) the indentation depth is substantially smaller than in the Vickers hardness test so that the hardness changes (consequently temperature changes) at very shallow depths can be detected.

B.9 Elevated Temperature Nitrogen Ion Implantation

The Plasma Source Ion Implantation (PSII) process has been applied to two Fe-Ni based superalloys, INCOLOY (trademark of International Nickel Company) alloys 908 and 909. Nitrogen was implanted at about 50 kV to a dose of 3×10^{18} ions/cm² and the sample temperature was intentionally raised to approximately 550°C to promote thermal diffusion. The cross-sectional optical microscopy of the implanted samples showed that for both alloys, a surface layer 15 to 20 μm thick developed on the surface. Auger analysis of the nitrogen concentration for the two alloys indicated a subsurface maximum, then a somewhat lower but constant value up to about 5 μm , followed by a decrease that was characteristic of thermal diffusion. Both x-ray diffraction and transmission electron microscopy confirmed the formation of nitrides at the surface. Microhardness measurements of the implanted layer showed that an improvement of over 200% in Knoop hardness was achieved at the surface for both alloys. Hardness improvements for alloy 908 were superior to alloy 909, presumably due to the presence of Cr which forms a hard, stable nitride. We have observed similar results in studies on elevated temperature PSII of alloy steels.

(continued)

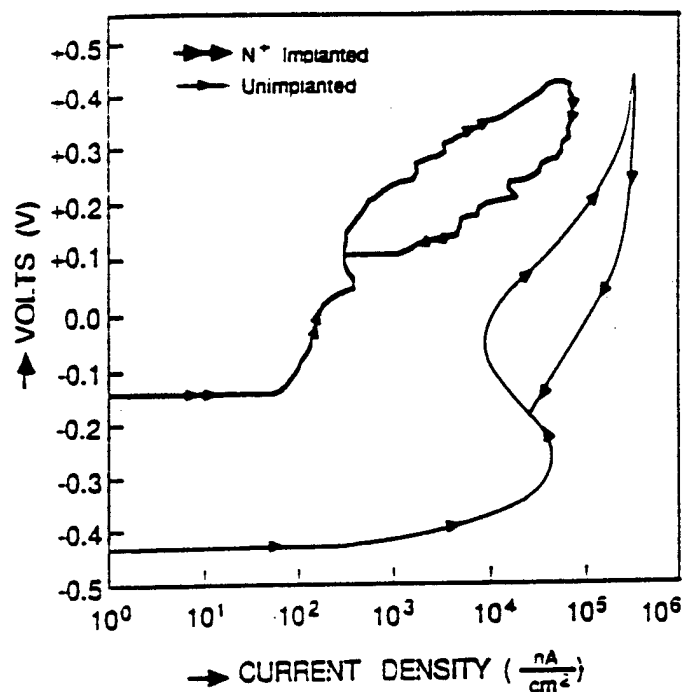

Fig. 8. Results of the cyclic potentiodynamic corrosion test conducted in 0.01N NaCl solution for unimplanted and implanted samples of the two alloys.

The results of cyclic potentiodynamic corrosion tests (in 0.01 N NaCl electrolyte) for implanted and unimplanted samples of alloys 908 and 909 are shown in Fig. 8. For alloy 908, implantation caused potentials to be shifted to more positive values, implying an increase in resistance to localized corrosion. For alloy 909, the improvements were not significant. Both alloys in general did not have a tendency to passivate and this effect was further decreased after implantation.

B. 10 Deposition of Titanium Nitride Films on AISI 52100 Bearing Steel

We have successfully produced TiN films on AISI 52100 bearing steel. The procedure involved sputter depositing a 300Å titanium layer using a dc sputter cathode biased at -600V in an argon plasma while the target was pulse-biased at 35 kV. This was followed by nitrogen implantation at 50 kV to a dose of 6×10^{16} ions/cm². The procedure was repeated three times to achieve a layer about 0.1 micron thick. At the end of three cycles, the layers were implanted with nitrogen at 50 kV to a dose of 3×10^{17} ions/cm². Auger analysis indicated the formation of stoichiometric TiN at oxygen levels comparable to previous studies. Surface Knoop microhardness improved from 970 to 1420 kg/mm² (with a corresponding increase in wear resistance), while the coefficient of friction against a ruby ball stylus decreased from 0.60 to 0.25, after the surface treatment.

B.11 Deposition of Chromium Nitride Films on AISI 52100 Bearing Steel

Stoichiometric chromium nitride films have been successfully deposited on AISI 52100 bearing steel by using the PSII process in the IBED mode (Fig. 9). A gas mixture of 62%N/38% Ar resulted in a 400Å layer after 75 minutes while a 58%N/42%Ar mixture yielded a deposition rate of approximately 400Å/hour. These runs used a filament discharge system to generate the plasma.

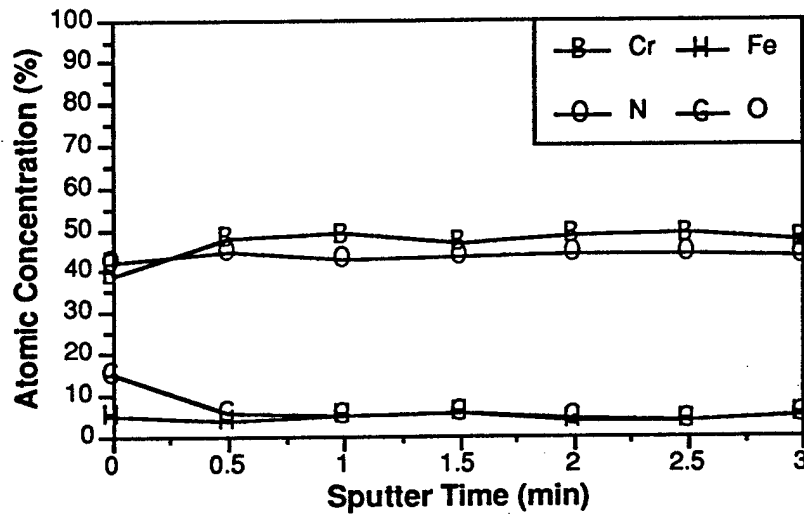

Fig. 9. Composition profile of a IBED-CrN coating. Note the near 1:1 ratio of Cr and N and the low percentage of oxygen.

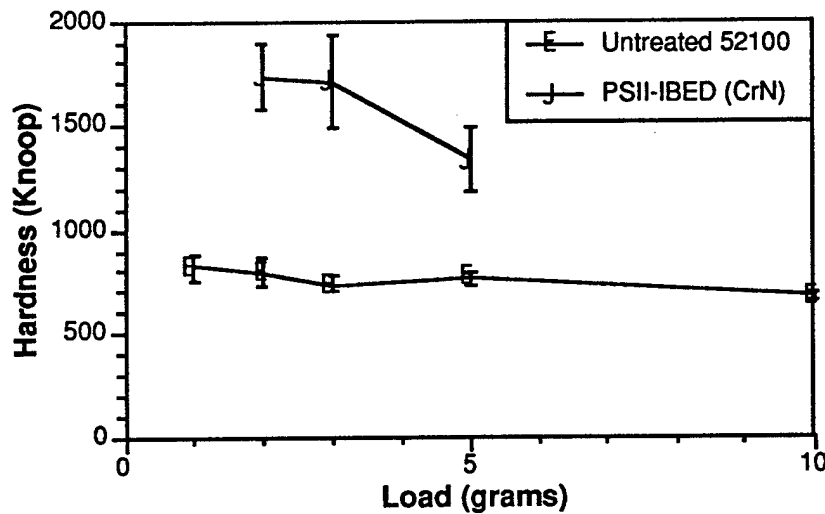

Fig. 10. Knoop microhardness of CrN coating deposited 52100 steel.

Surface roughnesses of IBED coatings were measured using an alpha-step profilometer. Prior to the IBED treatment the samples had an approximate root mean square surface roughness (R_a) of 120\AA while for the resulting IBED coatings R_a averaged 200\AA . The results of low load Knoop microhardness measurements shown in Fig. 10 indicate that the surface hardness is significantly increased in the near surface regions as a result of the IBED treatment. It should be noted however that even at the lowest load employed, the indentation depth is a substantial fraction of the implanted layer thickness so that the hardness improvements are underestimated. Rockwell hardness measurements of the substrate indicated that the sample temperature did not exceed 200°C during the IBED processing.

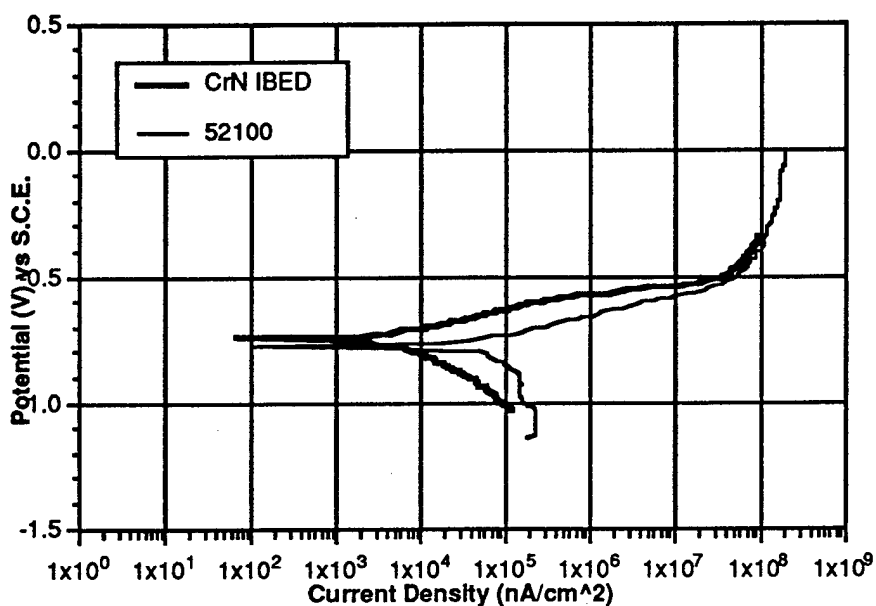

Fig. 11. Accelerated corrosion tests in 0.5 M NaCl solution (near seawater concentration)

(continued)

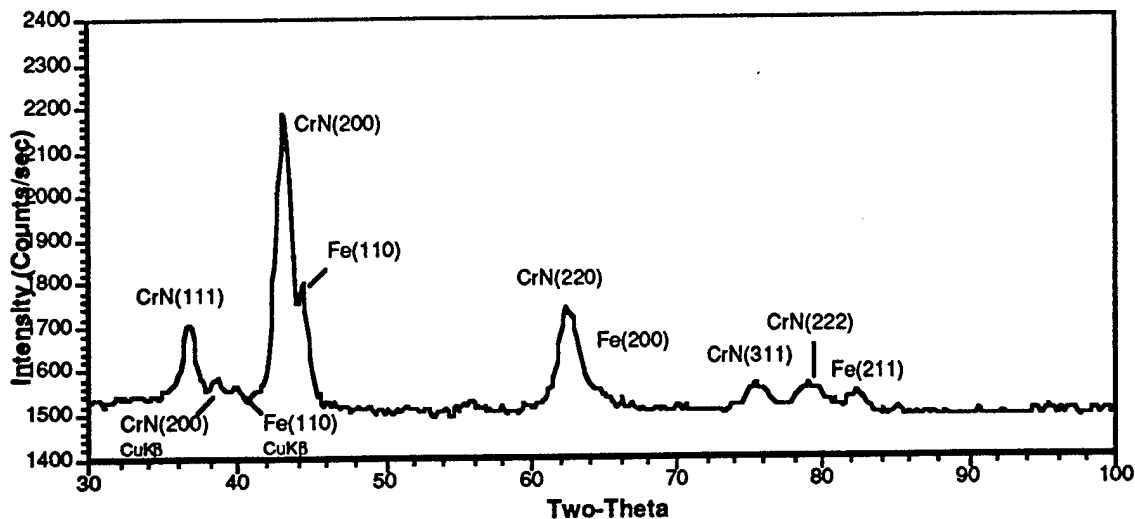

Fig. 12. Grazing incidence x-ray diffraction scan of a CrN coating.

Originally, IBED films were scratch tested for adhesion using equipment at the Basic Industrial Research Laboratory (BIRL) in Evanston, Illinois. This interaction prompted us to build a scratch tester which we are presently using for adhesion measurements. Corrosion testing was performed in 0.5 M NaCl (near sea water concentration) with a scan rate of 0.5 mV/s. Results of this test are shown in Fig. 11. We speculate that the presence of pin holes may be responsible for the lack of improvement. The reduction in pin hole density through process parameter control is a subject of ongoing investigation. We are performing grazing incidence (incidence angle 1.5 deg.) x-ray diffraction to evaluate the near surface crystallographic information without substrate interference. Fig. 12 shows a typical result of this study. Similarly PSII-IBED coatings of TiN and TaN have been deposited on Inconel 718 and Cu substrates, respectively.

B. 12 IBED of Chromium -Molybdenum Alloy

The aim of this research is to investigate the potential of IBED to produce corrosion and wear-resistant coatings which will: i) conserve expensive or critical materials by concentrating them in the surface where they are required for wear resistance and corrosion protection, ii) alter the surface of materials without sacrificing their bulk properties and iii) produce novel surface alloys unattainable by conventional metallurgical techniques.

The requirement of corrosion resistance suggests that chromium may be a major alloying element in the coating. The alloy chosen for study is Cr-Mo. The rationale for this choice is the beneficial effect of molybdenum in improving the corrosion resistance of stainless steels, e.g., the enhanced corrosion resistance of type 316 stainless steel (containing ~2% Mo) vs. type 304 stainless steel (containing no Mo). The molybdenum in stainless steel plays the role of

improving the integrity of the passive film, so the passivation characteristics of the IBED surface is a major point of this study.

The Cr-Mo IBED films were made by sputter deposition of Cr and Mo onto 304 stainless steel and low carbon steel substrates while simultaneously mixing the resulting film with krypton gas. The deposition parameters are summarized in Table II.

Table II. PSII processing conditions for producing Cr and Cr-Mo alloy IBED films.

Parameters	IBED 1 (Cr-4.3 at % Mo)	IBED 2 (Cr-0 %Mo)
Mixing Gas	Krypton	Krypton
Target Voltage	24 KV	24 KV
Base Pressure	9.0×10^{-6} Torr	6.0×10^{-6} Torr
Temperature	25°C	25°C
Deposition Rate	33 Å/min	30.5 Å/min
Operating Pressure	1.1×10^{-3} Torr	1.1×10^{-3} Torr
Fluence (dose per layer)	1.2×10^{17} ions/cm ²	1.23×10^{17} ions/cm ²
Sputter Cathode Plate Voltage	500 V	400 V
Total Time	183 min	188 min
Layer Thickness	6000 Å	5700 Å

The surface of the Cr and Cr-4.3 at % Mo IBED specimens were examined using scanning electron microscopy (SEM) prior to the corrosion test to ensure that the IBED layer was free of surface defects such as microporosity and pinholes. The examination indicated a continuous uniform film, free of microporosity. Auger electron spectroscopy (AES) compositional depth profiles showed a constant distribution of the chromium and molybdenum throughout the depth of the films. X-ray diffraction studies of the Cr-4.3 at % Mo alloy showed a BCC crystal structure.

Scratch tests were conducted at loads ranging from 50 to 400 grams. The films cracked at a load of 400 grams, however, they did not chip off. The adhesion strength σ_A (Kgf/mm²) was calculated using the following equation (P. Benjamin and C. Weaver, Proc. Roy. Soc., A254,1960, p.163.):

$$\sigma_A = K \frac{2W}{\pi Rb}$$

Where:

R = radius of the scratch point (mm) - 0.2 mm

W = observed critical load (Kgf) = 0.4 Kg

K = coefficient depending on the model used, for simplicity, K = 1

b = width of the track left on the film

b1 = 0.092mm (IBED 1 Cr-4.3 at % Mo)

$b_2 = 0.081\text{mm}$ (IBED 2 Cr-0% Mo)

$\sigma_{A,1} = 13.480\text{ Kgf/mm}^2$ and $\sigma_{A,2} = 15.719\text{ Kgf/mm}^2$

The corrosion studies to date have consisted of determining potentiodynamic anodic polarization behavior of the films in 0.1N H_2SO_4 and 0.1 M NaCl solution. A Model 350A corrosion measurement system was used. The results obtained are significant; lower passive current densities and more noble corrosion potentials (E_{CORR}) were observed for IBED samples with respect to 304 stainless steel, electroplated chromium and low carbon steel. The results for sulfuric acid and sodium chloride electrolytes are shown in Fig. 13 a and b, respectively. Important aspects of this data are summarized in Tables III and IV, respectively.

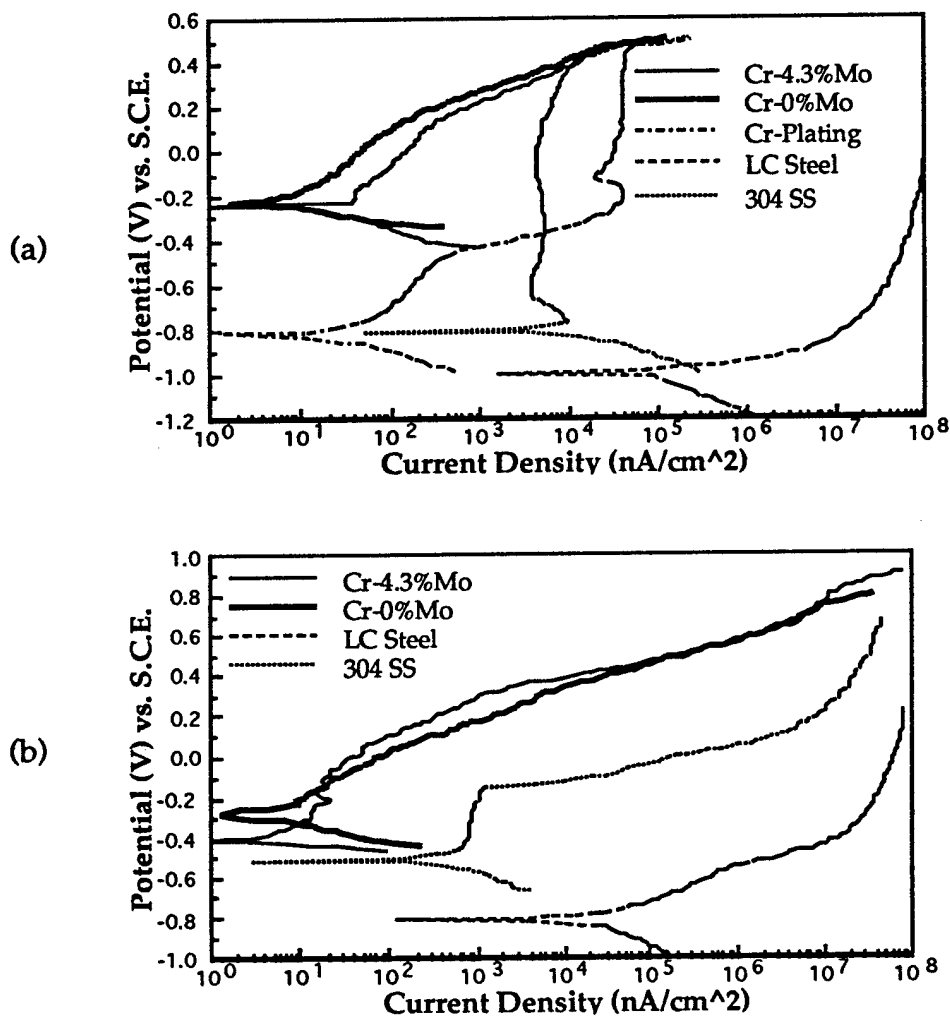

Fig. 13. Results of the corrosion tests for the IBED treated samples and a number of substrates substrates in (a): sulfuric acid (b): sodium chloride.

Table III. Summary of the relevant data from the tests performed in sulfuric acid.

Materials	E_{corr}	I_{corr} (nA/cm ²)
LC-steel	-0.975	1.0×10^5
304 S.S.	-0.815	9.93×10^3
Cr-electroplating	-0.820	3.5×10^1
IBED 1	-0.239	1.397×10^1
IBED 2	-0.230	0.70×10^1

Table IV. Summary of the relevant data from the tests performed in sodium chloride solution.

Material	E_{corr} (V vs SCE)	E_b (Pitting Potential)
LC-Steel	-0.800	No Passivity
304 S.S.	-0.520	-0.150
IBED 1	-0.410	+0.850
IBED 2	0.280	+0.800

Sensitivity towards crevice corrosion is perhaps the greatest weakness of stainless steel, and pitting of stainless steel is often connected with crevices and deposits. Crevice attack on stainless steels starts as small pits and the presence of O₂ and Cl⁻ are necessary prerequisites for both pitting and crevice corrosion of stainless steel. The pitting potential of the 304 stainless steel in 0.1 M NaCl solution was -0.150 V vs. SCE (saturated calomel electrode-used as reference) while the pitting potentials of IBED 1 and IBED 2 films were 0.850 V and 0.800 V with respect to SCE.

B.13 IBED of Chromium Nitride on Computer Hard Discs

The widespread use of computer technology has placed increasing demands on computer hardware manufacturers to produce hard drives that last longer, store more information but remain small and lightweight. A general approach to improve hard drive lifetime is to deposit a thin, wear resistant carbon overcoat on the thin film magnetic media (hard discs) used in hard drives. A typical computer hard disk is multilayered and consists of a NiP plated Al substrate, a Cr underlayer, a Cr-Co alloy magnetic layer, a protective carbon overcoat and a fluorocarbon lubricant film. During normal operation of a hard drive the read/write head rides on a cushion of air $\approx 0.1 \mu\text{m}$ above the rotating disc. However, during start-up and shut-down of the hard drive the head contacts the disc. With continued operation the inherently harder head begins to

cause wear on the disc. However it has been reported that the carbon overcoat applied for wear resistance is susceptible to oxidation, thereby giving rise to an oxidative-wear mechanism. Production of a CrN containing coating on the hard disc by the PSII technique offers a possible alternative route for improving the tribological properties of the discs.

We have performed a feasibility study of the use of nitrogen implanted chromium as a protective overcoat for thin film magnetic media. Computer hard discs pre-sputtered with chromium were implanted with nitrogen using the PSII process to produce a chromium nitride containing layer approximately 250Å thick. The conditions for sputtering and implantation were determined using the computer simulation code TAMIX discussed earlier (see Fig. 5).

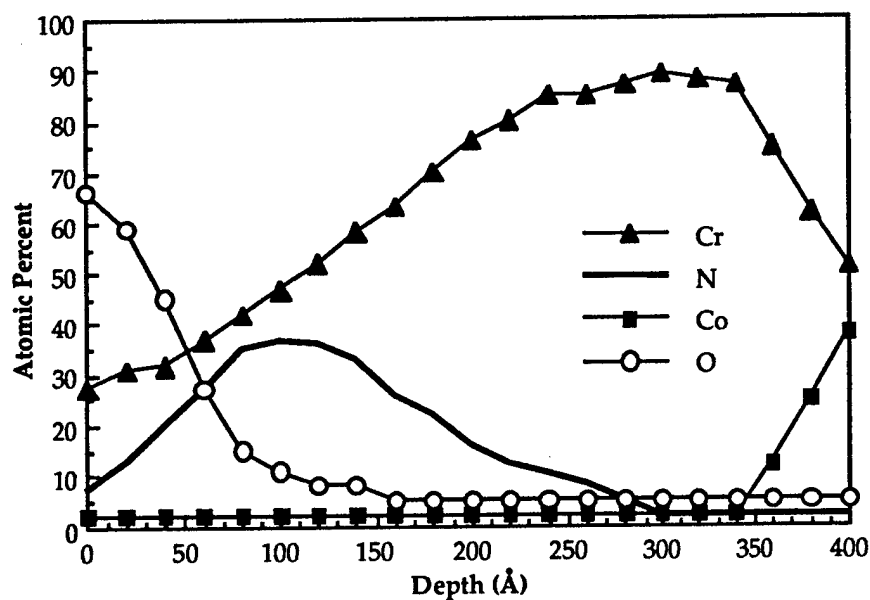

Fig. 14. Elemental concentration-depth profiles as determined by Auger electron spectroscopy.

Elemental concentration-depth profiles using a scanning Auger microprobe verified the presence of chromium nitride in the implanted layer (Fig. 14). Nanohardness measurements (Fig. 15) showed that the near surface hardness improved after implantation but it was lower than the traditional carbon overcoat. Pin-on-disc wear testing results shown in Fig. 16a indicated the implanted layer to be superior to the carbon overcoat while the industrial standard thin film head-on-disc wear test (Fig. 16b) indicated that the friction level was lower for the implanted layer.

(continued)

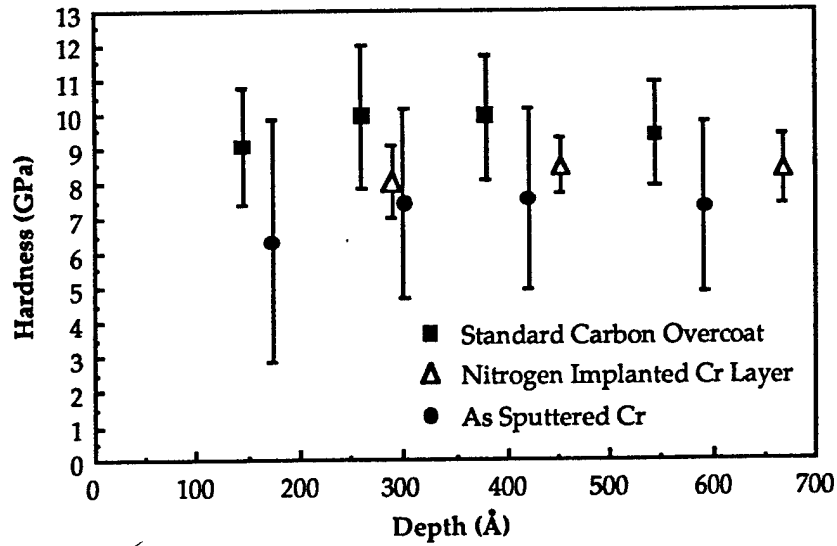

Fig. 15. Nanohardness measurements comparing the standard carbon overcoat, the as sputtered Cr layer and the nitrogen implanted Cr layer.

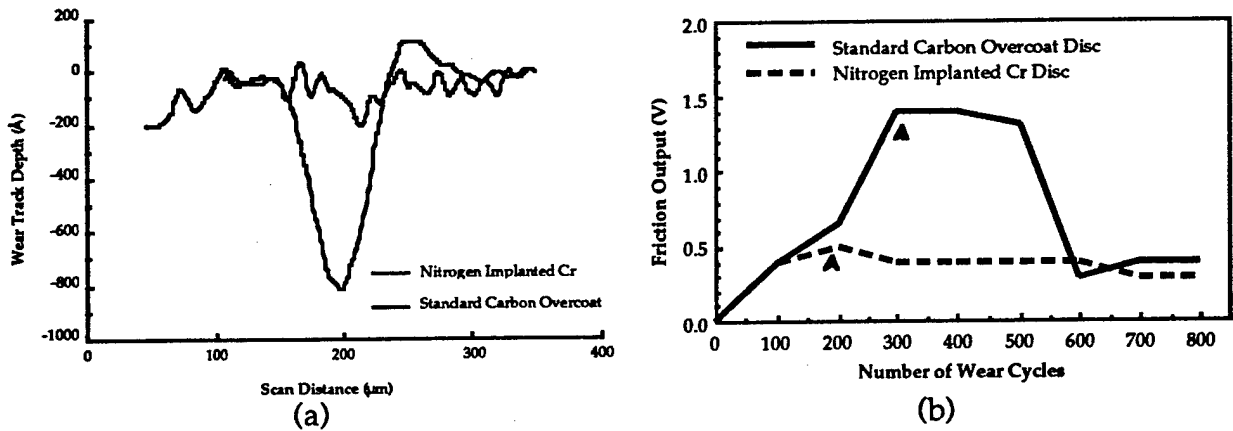

Fig. 16. Results of the wear tests performed on the carbon overcoat and nitrogen implanted Cr layer (a) pin-on-disk (b) thin film on head-on-disc wear tests.

B.14 Instrument Development

We have designed and constructed a fretting wear tester with the assistance of technical personnel at the Engineering Research Center for Plasma

Aided Manufacturing at University of Wisconsin-Madison. The machine uses an electro-mechanical actuator to provide a linear displacement of a stylus or flat against the test coupon. The design provides for wide range adjustment of the fretting parameters of loading force, frequency and displacement. These options allow simulation of a wide range of fretting wear applications. At the resonance frequency of the actuator/stylus assembly (about 40 Hz), a relative indication of frictional resistance during a fretting cycle can be obtained. The machine is speculated to be of great value in simulating wear in many defense applications such as helicopter components.

A scratch tester has been designed and constructed to provide a qualitative measure of the adhesion of PSII-IBED coatings to the substrate. Here a diamond stylus is drawn across the coated surface, with a known normal load applied to the tip. The load is progressively increased until the film is detached from the substrate. The load at which the film delaminates (as examined under a microscope) is taken as a measure of the film adhesion.

B.15 Technology Transfer Activities with Defense and Defense-Related Institutions

A significant accomplishment in of this research has been our interaction with the personnel at various defense and defense related institutions. This interaction has taken place in a variety of forms: visits by U.S. Army laboratories' personnel to our laboratories, visits by Prof. J.R. Conrad to various U.S. Army laboratories, and technical presentations. We have forged a close link with many laboratories under the U.S. Army and others which are performing research directly related to the interests of the U.S. Army.

The interaction has been invaluable to us both in terms of identifying applications for PSII and providing the direction for our research. It has also provided us the opportunity to field test PSII treated parts and components in accelerated field tests that are available at the U.S. Army R & D laboratories. For example, the salt fog test was performed on PSII treated INCONEL 718 bolts at Corpus Christi Army Depot (CCAD) while a spark erosion test of TiN deposited Cu and Al alloy samples is scheduled to be performed at Army Research, Development and Engineering Center (ARDEC). These tests, coupled with a range of test at University of Wisconsin-Madison will continue to provide a realistic picture of the applicability of PSII to various application. Figure 17 shows some of the parts treated by PSII. In the following section we have provided a summary of our interaction with defense and defense related institutions that have emerged from this U.S. Army grant.

(continued)

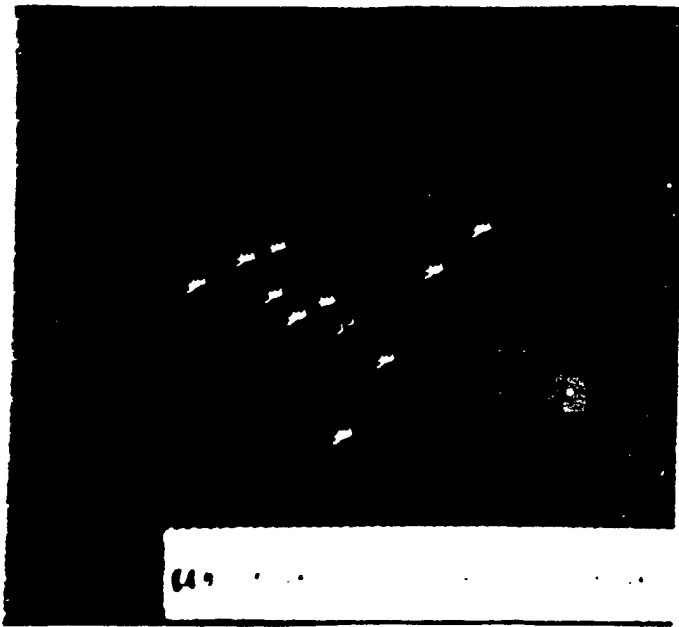

(a)

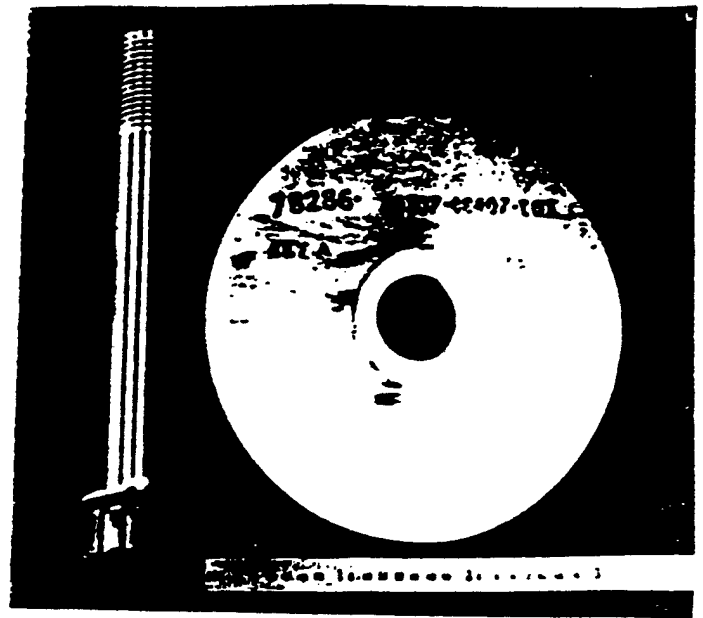

(b)

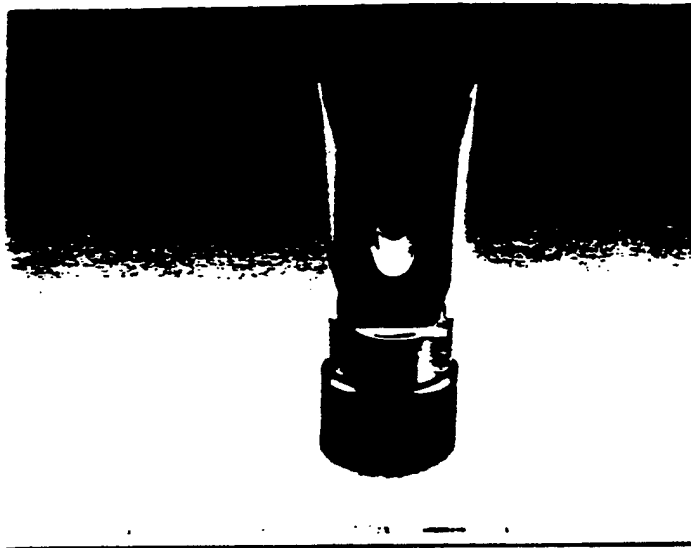

(c)

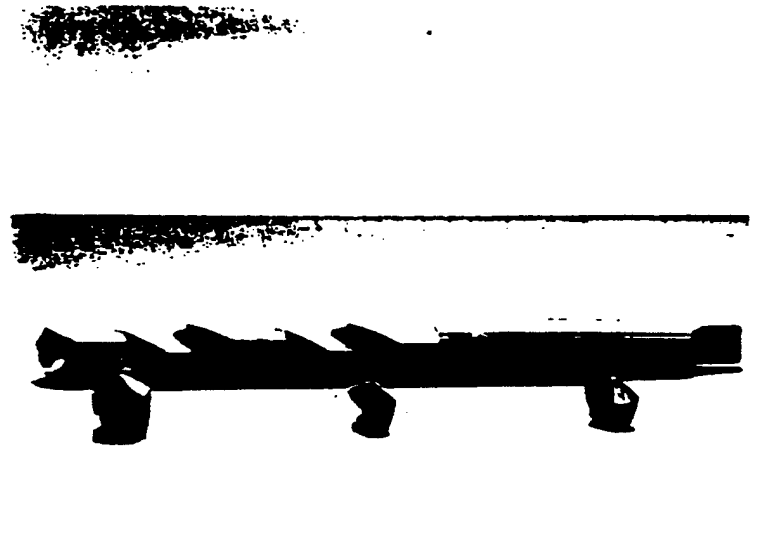

(d)

Fig. 17. Examples of parts treated with PSII (a): ball bearings for Kearfott Guidance and Navigation (b): Inconel 718 bolt and stainless steel washer for Corpus Christi Army Depot (CCAD) (c): aluminum alloy armatures for Army Research, Development & Engineering Center (ARDEC) (d): drills analyzed for Rock Island Arsenal.

Kearfott Guidance and Navigation, Wayne NJ

We have collaborated with Kearfott Guidance and Navigation, Wayne, NJ, on improving the lifetime of 440C stainless steel and AISI 52100 steel balls utilized in gyroscope spin bearings. The ball bearings were 3/32" in diameter and the dimensional tolerances for this application are on the order of a few parts per million.

The PSII surface modification route has a number of advantages for this application: (i) extreme dimensional integrity and surface finish are achieved, (ii) processing is carried out near room temperature so there is no degradation of the bulk properties of the bearings and (iii) because of the non-line-of sight nature of the PSII process there is no sputtering of atoms of the target surface which would lead to surface recession and consequently a loss in dimensional integrity; this is a major consideration in beam-line ion implantation for ions impinging at non-normal incidence.

Because a point of contact between the stage and the balls is inevitable, a proprietary fixture to provide a planetary motion in the chamber during processing, was designed and constructed at Kearfott Guidance and Navigation. Four batches (two each of 440C and 52100) were nitrogen ion implanted at 50 kV to doses of 1 and 3×10^{17} ions/cm², respectively. Two batches (two each of 440C and 52100) were treated with a CrN coating using the PSII process. Five balls in each batch were retained at University of Wisconsin-Madison for surface characterization. Scanning Auger analysis at different locations on the ion-implanted balls indicated a good dose uniformity, with a peak nitrogen concentration of about 20% nitrogen (see Fig. 18). As shown in Fig. 19, Auger analysis of the IBED treated balls showed that a uniform CrN layer about 2000Å in thickness had been successfully deposited.

The balls are presently awaiting field testing at Kearfott Guidance and Navigation where they will be installed in a gyroscope. A technique that monitors the power expended by frictional forces between the ball bearing and the race, during operation will be used to evaluate improvements in the PSII treated bearings. Our discussions with Mr. Ed Howe of Kearfott Guidance and Navigation have indicated that an improvement factor of 1.5 to 2 would be significant for this application.

(continued)

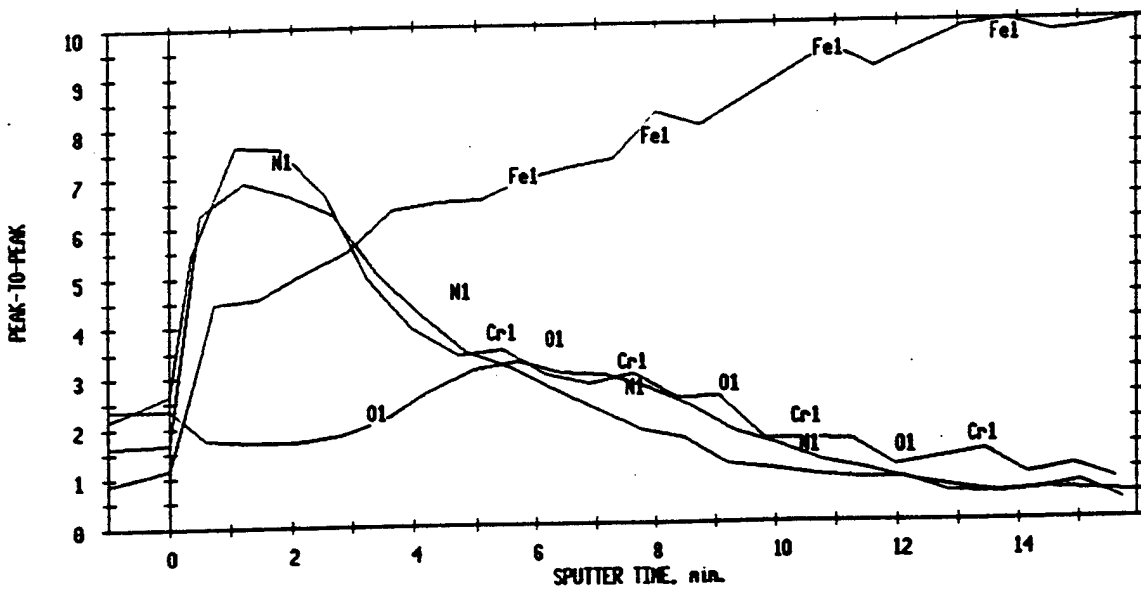
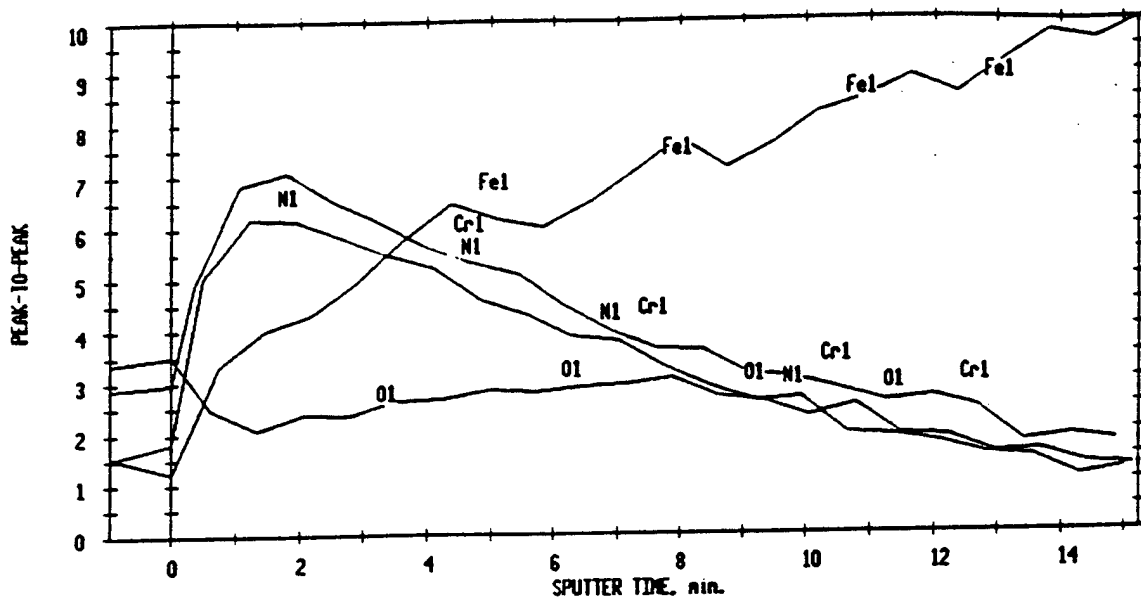

Fig. 18. Auger analysis of PSII nitrogen implanted ball bearings at two different locations.

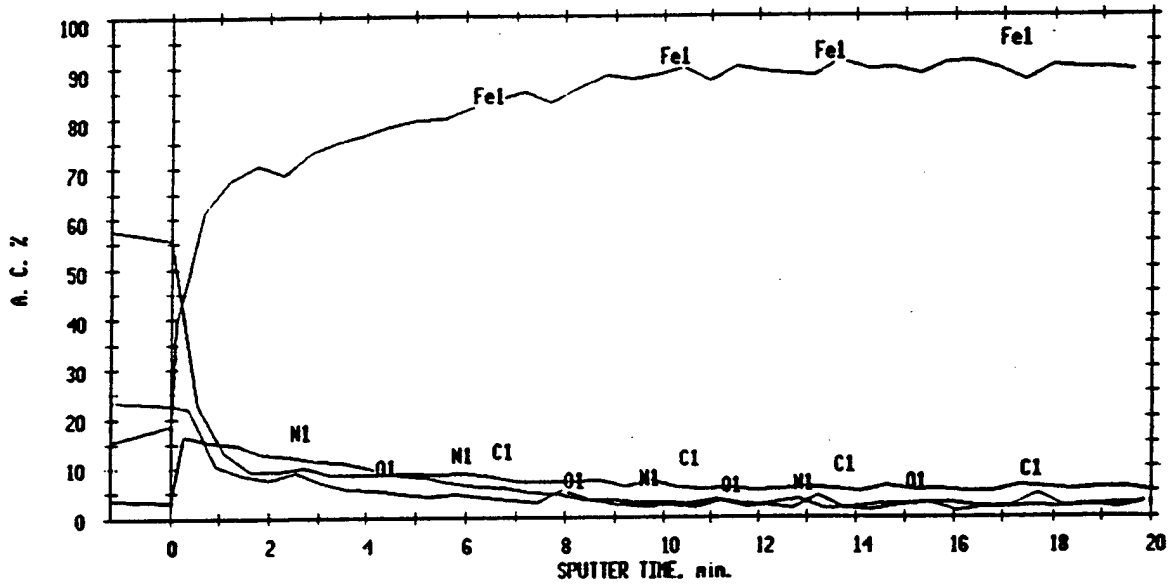
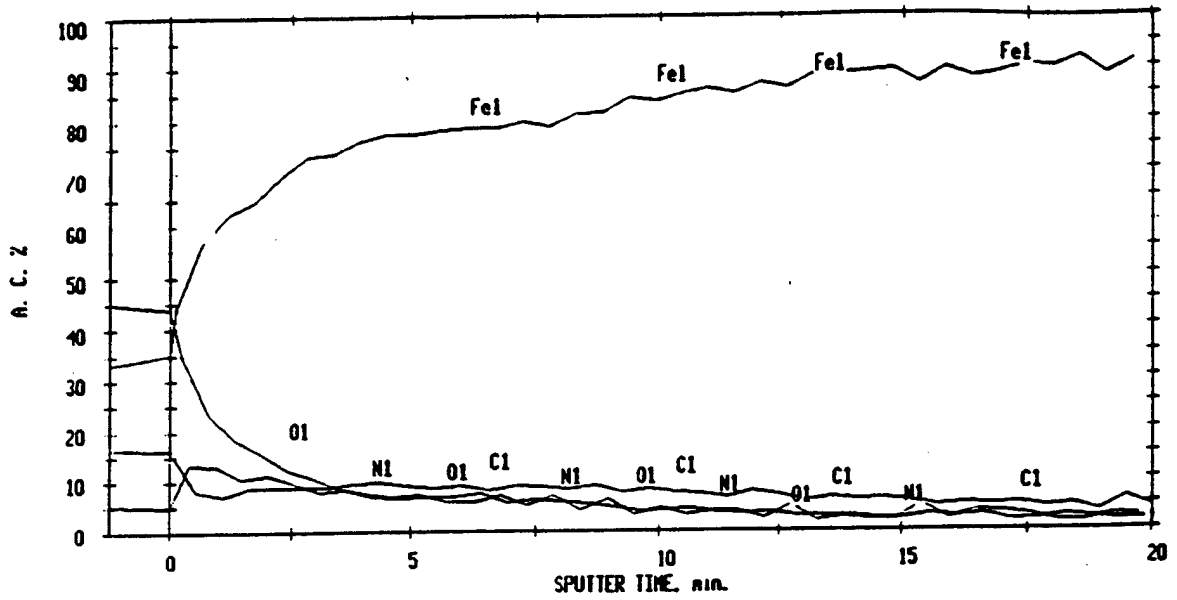

Fig. 19. Auger analysis of PSII-IBED CrN treated ball bearings at two different locations.

Corpus Christi Army Depot (CCAD), Corpus Christi, TX

Our interaction with CCAD began in 1988. Mr. Al Gonzales of CCAD visited Madison and gave a seminar on potential applications of ion implantation at CCAD facilities. CCAD was already involved in ion implantation via the MANTECH program under the auspices of the U.S. Dept. of Navy. We have treated some INCONEL 718 bolts and stainless steel washers for CCAD which were subjected to the rigorous salt fog test at CCAD. However, little or no improvement was observed as a result of the PSII treatment. Based on our recent success with nitrogen implantation of Al, development of RF plasma source and the fretting wear tester we are identifying other applications where we believe the improvement factors would be significant. Dr. John Conrad was awarded the Team Player Award by the Hot Chips and Blue Chips Quality Circles, Corpus Christi Army Depot in September, 1994.

Army Research, Development and Engineering Center (ARDEC), Picatinny, NJ

In May, 1992, Dr. Otooni from ARDEC, Picatinny, NJ, visited our laboratory to discuss the application of PSII for components used in the electric rail guns. Of particular interest was the improvement in wear resistance of aluminum alloy armatures and copper rails, where intense frictional heating can severely limit the frequency and the total number of projectiles that can be fired continuously. Titanium nitride and tantalum nitride coatings were deposited on the rails and armatures at the University of Wisconsin by using the PSII process in the IBED mode. The coated copper rails showed an improvement in wear and pitting resistance by about 20 to 30%. The PSII-coatings improved the armatures' transition velocity by 70%. University of Wisconsin also performed coating characterization studies using Auger analysis, alpha-step profilometry, and hardness measurements. The results of this interaction are detailed in a technical report and a paper attached to this report.

Rock Island Arsenal, Rock Island, IL

Our interaction with this Rock Island Arsenal began with a visit by Dr. Moriarity and Dr. Kalkan (of RIA) in August 1991. We had detailed discussions on wear and corrosion problems encountered at army facilities, and the recent EPA regulations dictating a drastic reduction in processes detrimental to the environment both from chemical and noise stand points. In the first interaction our goal was to compare the wear life times of the drills in the following conditions: (a) untreated (b) TiN coated (c) TiN coated + beam-line ion implanted (d) TiN coated + PSII-nitrogen implanted, and (e) TiN coated + PSII-carbon implanted. We believe that the non-line of sight nature of the PSII process would offer advantages over the conventional beam line implantation. Field testing of the PSII-treated drills at Rock Island Arsenal using the freeze-frame technique showed that implantation of carbon into a titanium-nitride coated drills holds

considerable promise for improving drill life. A report detailing this study is attached.

A technique is being developed to deposit coatings on the inside of hollow cylinders. An application for a patent has been submitted to the University of Wisconsin patent office. The technique will have profound implications for deposition on the insides of cylinders; we are discussing potential collaborations with Rock Island Arsenal in this area and also in the area of minimization of environmentally hazardous Cr-plating.

Allison Gas Turbine, Indianapolis, IN

PSII-nitrogen implanted 17-7 PH stainless steel samples were subjected to an aggressive erosion and corrosion tests at Allison Gas Turbine.

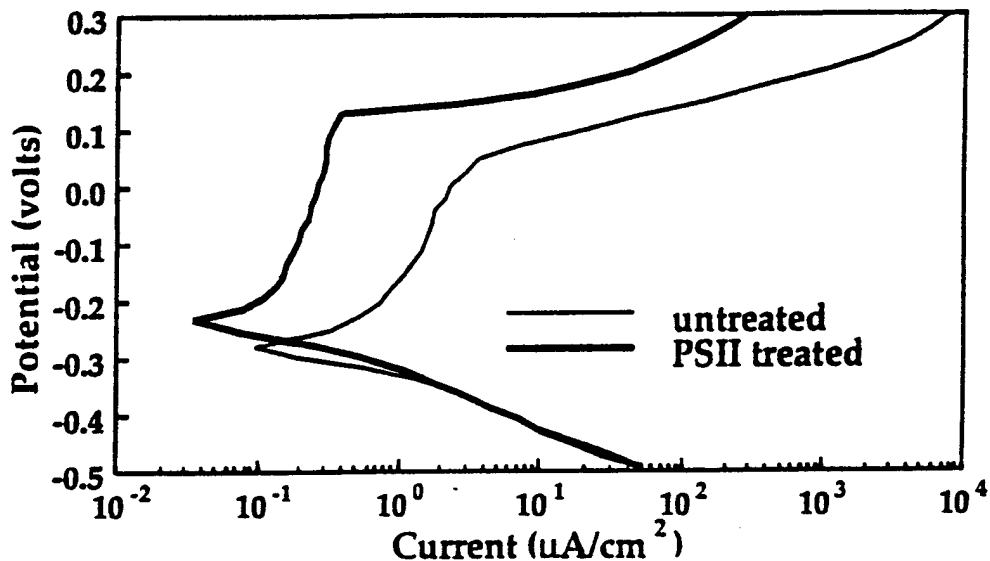

Fig. 20. Results of accelerated corrosion test performed in sea-water concentration sodium chloride solution for PSII treated and untreated 17-7 PH stainless steel (test performed at Allison Gas Turbine).

The erosion test was carried out under the following conditions: air pressure 70 psi, attack angle 30 deg., erosion sand 90 mesh alumina powder. An improvement of 11 % was realized in the PSII treated sample. The results of the polarization test carried out in 3.5% NaCl solution (sea water concentration) are shown in Fig. 20. The implanted sample shows a lower current density, implying a lower corrosion rate. The higher critical pitting potential (E_c) of the implanted sample indicates a better pitting corrosion resistance. Evidence of crevice corrosion was observed at the masked boundary on the uncoated sample, while little crevice corrosion was developed on the implanted sample. The test results suggest that the implanted sample had better corrosion resistance in every aspect as compared to the untreated sample.

National Aeronautics and Space Administration, Huntsville, AL

Our interaction with NASA has been in the area of improving the rolling contact fatigue resistance of 440C stainless steel bearings through PSII surface modification. We implanted two such bearings with nitrogen and sent them to NASA for traction testing. Unfortunately it was determined later that the bearings were made of substandard steel.

Los Alamos National Laboratories, Los Alamos, NM

Our interaction with LANL is more process oriented. LANL through the federally sponsored Cooperative Research and Development Agreement (CRADA) program is collaborating with us in the construction of a large PSII system (15 ft.x 3 ft). This facility is intended for use in both plasma physics research and to improve metallurgical properties of engineering materials. This interaction has led to a number of two way visits by Dr. D. Rej to our laboratories and Prof. J.R. Conrad to LANL.

Lawrence Berkley Laboratories, Berkley, CA and Basic Industries Research Laboratories, Evanston, IL

After a detailed discussion at University of Wisconsin-Madison between Dr. K. Legg (BIRL), Dr. I. Brown (LBL) and us, a three way interaction was conceived. LBL will deposit metal coatings on stainless steel using the MEVA source. The hardness and tribological properties of the samples will be evaluated at University of Wisconsin-Madison and BIRL will perform scratch tests for adhesion measurements.

Personnel Visits

During the course of funding of the U.S. Army grant the following visits were made to the PSII program, University of Wisconsin-Madison:

- Mr. Al Gonzales, Corpus Christi Army Depot-*"Presented a seminar on wear problems in tools at CCAD and their involvement with MANTECH program"*.
- Dr. Kalkan and Dr. Moriarty, Rock Island Arsenal-*"Discussion on wear problems in drills and other tools at Rock Island Arsenal methods of evaluating wear and environmental issues"*.
- Dr. Otooni, Army Research, Development and Engineering Center-*"Discussion on problems of wear in the electric gun application"*.
- Dr. Culbertson, formerly of U.S. Army Materials Research Laboratories: *"Seminar on materials issues in defense, their work with ion implantation"*.
- Dr. Reeber, US Army Research Laboratories-*"Presented seminar on priorities and recent materials related research activities at US Army Labs"*.

- Dr. Sproul, Basic Industries Research Laboratories: "*Seminar on production of coatings by CVD and PVD techniques and coating characterization issues*".
- Mr. Ed Howe, Kearfott Guidance and Navigation: "*Two visits: The first one involved discussions, the second one was a three day visit where Mr. Howe oversaw PSII treatment of ball bearings*".
- Dr. Adams, General Electric: "Seminar on problems of nodular corrosion of Zr alloy fuel cladding rods".
- Dr. Rej, Los Alamos National Laboratories: " *Seminar and discussion on construction of PSII chamber at LANL*".

The following visits were made by Prof. J.R. Conrad during the the U.S. Army grant:

- To Lawrence Berkley Laboratories, General Discussion.
- To participate in US Army Research and Technical Transfer of Ion Implanation Technology for Specialty Metals Knoxville, TN.
- To participate in US Army Assessment of Environmentally Acceptable Alternative Surface Treatment, Champaign, Ill.
- Corpus Christi Army Depot: Presented a seminar at the American Helicopter Society.
- Visit to Rock Island Arsenal with Dr. Culbertson: General discussions.
- Visit by PSII group to Basic Industries Research Labs, Evanston, Ill.
- Visit by the PSII group to Rock Island Arsenal, Rock Island, Ill.

B.16 First International Workshop on Plasma-Based Ion Implantation

The First International Workshop on Plasma-based Ion Implantation held at Madison, WI, August 4-6,1993, was an outstanding success, bringing together, more than 100 delegates representing universities, national laboratories, defense and federal agencies, equipment manufacturers and potential end users of the technology. The attendance reflected the growing world-wide interest in PSII due to its applicability to wide range of materials and materials processing problems. The original research on PSII in the late 1980s at the University of Wisconsin (funded partly by USARO) has to date spawned over 30 research groups world-wide, with new facilities being established at a rapid rate. In all there were a total of 22 oral presentations and 49 poster presentations, and of these a total of 36 papers were published in the March/April, 1994, issue of Journal of Vacuum Science and Technology B (copy attached). Financial support for the workshop was provided by Applied Science and Technology, General Motors Corporations, Hughes Aircraft, National Electrostatics, the United States Army Research Office, and Varian Associates.

Dr. Robert Reeber of USARO convened a panel of attendees to make an assessment of this emerging technology with the aim of evaluating research and technology, and commercial needs that would accelerate its implementation in the Department of Defense and the civilian sector. A copy of the findings of this panel are reported in a paper attached to this report. Dr. Hirvonen of Naval

Research Laboratory gave a keynote address on NRL activities in plasma surface modification of materials. Other presentations included PSII applications at ARDEC, Rock Island Arsenal, and U.S. Army Research Laboratory. Important presentations were made by attendees from Los Alamos National Laboratory, Lawrence Livermore Laboratory and Oak Ridge National Laboratory.

B. 17 Third Generation PSII System

In 1994 we completed the construction of a new third generation PSII system (see Fig. 21). The chamber is 36" in diameter, 40" in length, and has a working volume of of about 700 liters. A number of ports have been provided for pumps and diagnostics. The spectrum of energy ranges from 0.1 to 125 KeV and plasma is confined by means of an array of multi-dipole magnets. Plasma is generated using either filament, glow discharge, or RF methods. Working pressure is in the range of 5×10^{-5} to 10^{-3} Torr. A set of removable stainless liners that conform to the inner surface of the chamber has been built for use for plasmas that contaminate the chamber walls (eg. carbon). The system can be operated in both implantation and deposition modes and is also equipped to handle boron containing gases.

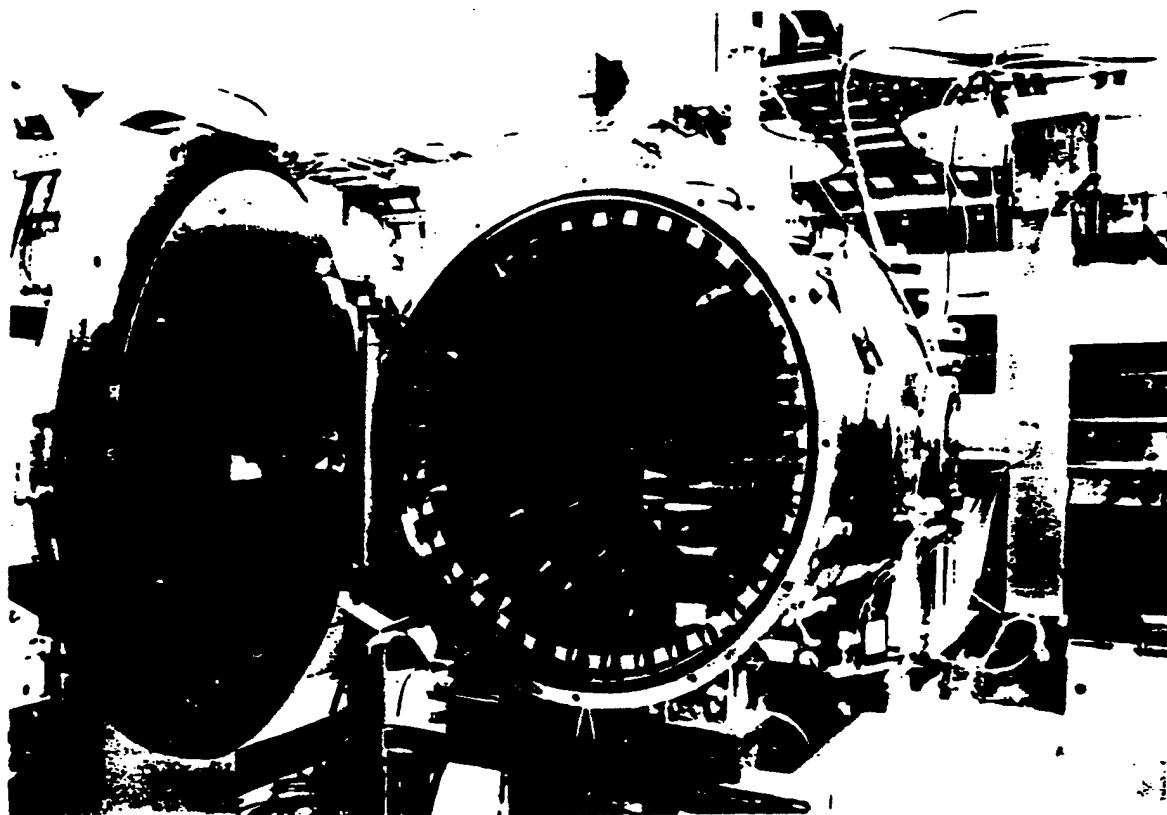

Fig. 21. Photograph of the third-generation PSII system built in 1994.

C. PUBLICATIONS ACCRUING FROM THE ARMY GRANT (attached)

1. "Model of Plasma Source Ion Implantation in Planar, Cylindrical, and Spherical Geometries"; J.T.Scheuer, M.Shamim, and J.R.Conrad, J. Appl. Phys. 67 (3) 1 1241 (1990).
2. "Ion Beam Assisted Coating and Surface Modification with Plasma Source Ion Implantation"; J.R. Conrad, R.A. Dodd, S. Han, M. Madapura, J.T. Scheuer, K. Sridharan and F.J. Worzala, Journal of Vacuum Science and Technology. A 8 (4), 3146 (1990).
3. "TAMIX-A Dynamic Mote Carlo Simulation Program of Ion-Solid Interaction"; S.H.Han, J.R. Conrad, partially reproduced in "Computer Simulation of Ion Beam Mixing", S.H. Han, G.L. Kulcinski and J.R. Conrad, Nuclear Instruments and Methods,, B45, 701 (1990).
4. "Elevated Temperature Ion Implantation: A New Direction for Surface Engineering"; F.J. Worzala, R.A. Dodd, M. Madapura and K. Sridharan, Proc. Intl. Conf. Surface Engineering: Current Trends and Future Prospects, Toronto, Canada, June,1990, Surface Engineering, ed. S.A. Meguid, p.177.
5. "Measurement of electron emission due to energetic ion bombardment in plasma source ion implantation"; M.M. Shamim, J.T. Scheuer, R.P. Fetherston and J.R. Conrad, J. Appl. Phys., 70, 4756 (1991).
6. "Measurements of spatial and temporal sheath evolution for spherical and cylindrical geometries in plasma source ion implantation"; M. Shamim, J.T. Scheuer and J.R. Conrad, J. Appl. Phys., 69, 2904 (1991).
7. "Comparison between conventional and plasma source ion-implanted femoral knee components"; A. Chen, J.T. Scheuer, C. Ritter, R.B. Alexander and J.R. Conrad, J. Appl. Phys., 70, 6757 (1991).
8. "Influence of temperature on nitrogen ion implantation of Incoloy alloys 908 and 909"; L.Xie, F.J. Worzala, J.R. Conrad, R.A. Dodd and K. Sridharan, Mat. Sci. and Eng., A139, 179 (1991).
9. "Two-dimensional measurement of sheath propagation and dose uniformity for planar targets in plasma source ion implantation", M. Shamim, J.T. Scheuer and J.R. Conrad, presented at American Vacuum Society-38 th National Symposium, Seattle, WA., Nov. 1991, student award winning paper .
10. "Nitrogen Implanted Chromium Overcoat for Improving the Durability of Thin Film Magnetic Media"; D.E. Muller, K.C. Walter, K. Sridharan, J.R. Conrad and S. Agarwal, Journal of Materials Engineering and Performance, 1, (4), 489 (1992).

11. "Glow Discharge Characterization of Plasma Source Ion Implantation". M.M. Shamim, P. Fetherston, K. Sridharan, and J. R. Conrad, Gaseous Electronics Conf., Boston, MA, October, 1992.
12. "Sheath Dynamics and Dose Analysis for Planar Targets in Plasma Source Ion Implantation", Plasma Sources Sci. Technol. 2, 81 (1993).
13. "Structure and Properties of Amorphous Diamond-like Carbon Films Produced by Ion Beam Assisted Plasma Deposition", J. Chen, J.R. Conrad, and R.A. Dodd, Journal of Materials Engineering and Performance, 2, (6), 839 (1993).
14. "Wear Improvement Evaluation of Non-Homogeneous Surface Modified Materials", Wear, 160, 105, (1993).
15. "Deposition of Nitride Coatings on Armatures and Rails in Electromagnetic Railguns", M.A. Otooni, K.C. Walter, R.P. Fetherston, K. Sridharan, A. Chen, M.M. Shamim, and J.R. Conrad, poster presentation at the First International Workshop on Plasma-based Ion Implantation", Madison, WI, August, 1993.
16. "Deposition of Titanium and Tantalum Nitride Coatings on Armatures and Rails in Electromagnetic Railguns"; R.P. Fetherston, K. Sridharan, A. Chen, M.M. Shamim, and J.R. Conrad, submitted to U.S. ARDEC, 1993. (technical report)
17. "Sputter Deposition of Tantalum Nitride Films on Copper using an RF Plasma", A. Chen, J.P. Blanchard, and J.R. Conrad, Materials Research Bulletin, 29 (8), 827 (1994).
18. "Nitrogen Plasma Source Ion Implantation of Aluminum", K.C. Walter, J. Vac. Sci. Technol., B 12(2), 945, 1994.
19. "Two-dimensional Fluid Modeling of Time-Dependent Plasma Sheath", M. Hong and G.A. Emmert, J. Vac. Sci. Technol., B 12(2), 889, (1994).
20. "Carbon Plasma Source Ion Implantation/Deposition of Drills Used at Rock Island Arsenal"; J.R. Conrad, K. Sridharan, R.P. Fetherston, A. Chen, M.M. Shamim, and J. Firmiss, submitted to Rock Island Arsenal, Rock Island, IL, May, 1994. (technical report)
21. "Overview of Plasma Source Ion Implantation Research at University of Wisconsin-Madison", S.M. Malik, K. Sridharan, R.P. Fetherston, A. Chen, and J.R. Conrad, J. Vac. Sci. Technol., B 12(2), 843, 1994.

22. "Application of Coatings for EM Gun Technology"; M.A. Otooni, A. Graf, G. Colombo, J.R. Conrad, K. Sridharan, M.M. Shamim, R.P. Fetherston and A. Chen, proc. conf. Materials Research Society symposium proc., November, 316, 577 (1994).
23. "Plasma Source Ion Implantation"; R.R. Reeber and K. Sridharan, *Advanced Materials and Processes*, 146, 6, 21 (1994).
24. "Distribution of Incident Ions and Retained Dose Analysis for a Wedge-Shaped Target in Plasma Source Ion Implantation"; S.M. Malik, D.E. Muller, K. Sridharan, R.P. Fetherston, and J.R. Conrad, *Journal of Applied Physics*, 77 (3), 1, (1995).
25. "A Fretting Wear Study of Nitrogen Implanted Titanium Alloy"; N. Horswill, K. Sridharan, and J.R. Conrad, *Journal of Materials Science Letters*, 14, 1349, (1995).

D. PARTICIPATING SCIENTIFIC PERSONNEL SUPPORTED BY THE PROJECT:

Faculty, Academic Staff and Interns:

Jake Blanchard
Gerrard Butz
An Chen
John R. Conrad
Paul Fetherston
Shamim Malik
Kumar Sridharan
Baoyin Tang

Graduate Students:

Mokhtar Abuzriba, Ph.D
Gaith Bashish, Ph.D
David Chapek, Ph.D
Jill Chen: Ph.D
James Firmiss, Ph.D (in progress)
Xiahong Qiu, Ph.D
Kevin Walter: Ph.D
Xiaoci Zheng, Ph.D
David Behling, M.S.
Brian Huxtable, M.S.
David Muller, M.S.
David Olson, M.S.
James Schnieder, M.S.
Paul Marko (discontinued)
Roger Feely (discontinued)

Undergraduate Students:

Marcus Dimick, B.S.
Nathaniel Horswill, B.S.
Lisa Paffrath, B.S.
Mark Richter, B.S.
Todd Wenger, B.S.