

**TRACING THE EVOLUTION OF THE  
CIVIL MILITARY OPERATIONS CENTER (CMOC)  
IN THE 90s: WHAT IS THE BEST MODEL?**

A Monograph  
By  
Major Mark A. Davis  
Armor



19960924 027

School of Advanced Military Studies  
United States Army Command and General Staff College  
Fort Leavenworth, Kansas

Second Term AY 95-96

Approved for Public Release; Distribution is Unlimited

# REPORT DOCUMENTATION PAGE

Form Approved  
OMB No. 0704-0188

Public reporting burden for this collection of information is estimated to average 1 hour per response, including the time for reviewing instructions, searching existing data sources, gathering and maintaining the data needed, and completing and reviewing the collection of information. Send comments regarding this burden estimate or any other aspect of this collection of information, including suggestions for reducing this burden, to Washington Headquarters Services, Directorate for Information Operations and Reports, 1215 Jefferson Davis Highway, Suite 1204, Arlington, VA 22202-4302, and to the Office of Management and Budget, Paperwork Reduction Project (0704-0188), Washington, DC 20503.

<b>1. AGENCY USE ONLY (Leave blank)</b>	<b>2. REPORT DATE</b>	<b>3. REPORT TYPE AND DATES COVERED</b> MONOGRAPH	
<b>4. TITLE AND SUBTITLE</b> Tracing the evolution of the Civil Military Operations Center (CMOC) in the 90s: What		<b>5. FUNDING NUMBERS</b>	
<b>6. AUTHOR(S)</b> is the best Model? MAJ Mark A. Davis			
<b>7. PERFORMING ORGANIZATION NAME(S) AND ADDRESS(ES)</b> School of Advanced Military Studies Command and General Staff College Fort Leavenworth, Kansas 66027		<b>8. PERFORMING ORGANIZATION REPORT NUMBER</b>	
<b>9. SPONSORING/MONITORING AGENCY NAME(S) AND ADDRESS(ES)</b> Command and General Staff College Fort Leavenworth, Kansas 66027		<b>10. SPONSORING/MONITORING AGENCY REPORT NUMBER</b>	
<b>11. SUPPLEMENTARY NOTES</b>			
<b>12a. DISTRIBUTION/AVAILABILITY STATEMENT</b>  APPROVED FOR PUBLIC RELEASE: DISTRIBUTION UNLIMITED.		<b>12b. DISTRIBUTION CODE</b>	
<b>13. ABSTRACT (Maximum 200 words)</b>  SEE ATTACHED  <div style="text-align: right; font-style: italic;">HIGH QUALITY INSPECTED 2</div>			
<b>14. SUBJECT TERMS</b> civil Military Operations Center (CMOC), Nongovernmental Organizations (NGO), Private Voluntary Organizations (PVO), Civil Affairs (CA), Operations Other than War (OOTW)		<b>15. NUMBER OF PAGES</b> 81	
		<b>16. PRICE CODE</b> War (OOTW)	
<b>17. SECURITY CLASSIFICATION OF REPORT</b> UNCLASSIFIED	<b>18. SECURITY CLASSIFICATION OF THIS PAGE</b> UNCLASSIFIED	<b>19. SECURITY CLASSIFICATION OF ABSTRACT</b> UNCLASSIFIED	<b>20. LIMITATION OF ABSTRACT</b> UNLIMITED

## ABSTRACT

TRACING THE EVOLUTION OF THE CIVIL MILITARY OPERATIONS CENTER (CMOC)  
IN THE 90s: WHAT IS THE BEST MODEL? by Major Mark A. Davis, USA, 81 pages.

This monograph seeks to develop a model for the employment of a civil military operations center based on available doctrine and the experience of the military in recent operations. The frequency of the U.S. military being employed in military operations other than war (MOOTW), the explosion of nongovernmental organizations (NGOs), private voluntary organizations (PVOs), and international organizations (IOs) and the doctrinal principle of unity of effort make the CMOC a central element in the way in which we conduct operations. Harnessing the efforts of NGOs can be thought of as a force multiplier in that it accommodates organic shortfalls in the military (or force caps of deployed forces) and creates a synergistic effect of the total resources available in theater. These factors become more and more critical as military commitments to MOOTW continue to increase.

The monograph begins with a discussion of the culture of humanitarian organizations. The paper then evaluates doctrine pertinent to the CMOC. Following the doctrinal review, three recent operations are examined: Operation Restore Hope, Somalia; Operation Support Hope, Rwanda, and Operation Uphold Democracy, Haiti. The study then develops a model CMOC based on the previously presented information.

The monograph concludes that common elements of doctrine, and each of the three operations can produce a model CMOC which can be helpful in writing more detailed doctrine on the subject.

SCHOOL OF ADVANCED MILITARY STUDIES  
MONOGRAPH APPROVAL

Major Mark A. Davis

Title of Monograph: Tracing the Evolution of the Civil Military Operations Center (CMOC) in the 90s: What is the Best Model?

Approved by:

  
\_\_\_\_\_  
LTC(P) Timothy Heihemann, MA Monograph Director

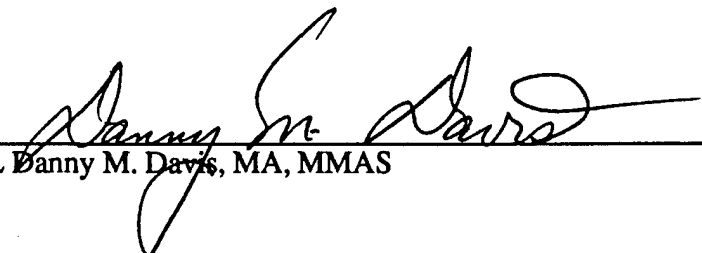
  
\_\_\_\_\_  
COL Banny M. Davis, MA, MMAS Director, School of Advanced Military Studies

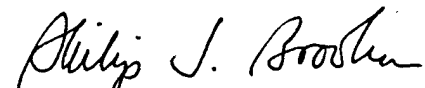
  
\_\_\_\_\_  
Philip J. Brookes, Ph.D. Director, Graduate Degree Program

Accepted this 23d Day of May 1996

## ABSTRACT

TRACING THE EVOLUTION OF THE CIVIL MILITARY OPERATIONS CENTER (CMOC)  
IN THE 90s: WHAT IS THE BEST MODEL? by Major Mark A. Davis, USA, 81 pages.

This monograph seeks to develop a model for the employment of a civil military operations center based on available doctrine and the experience of the military in recent operations. The frequency of the U.S. military being employed in military operations other than war (MOOTW), the explosion of nongovernmental organizations (NGOs), private voluntary organizations (PVOs), and international organizations (IOs) and the doctrinal principle of unity of effort make the CMOC a central element in the way in which we conduct operations. Harnessing the efforts of NGOs can be thought of as a force multiplier in that it accommodates organic shortfalls in the military (or force caps of deployed forces) and creates a synergistic effect of the total resources available in theater. These factors become more and more critical as military commitments to MOOTW continue to increase.

The monograph begins with a discussion of the culture of humanitarian organizations. The paper then evaluates doctrine pertinent to the CMOC. Following the doctrinal review, three recent operations are examined: Operation Restore Hope, Somalia; Operation Support Hope, Rwanda, and Operation Uphold Democracy, Haiti. The study then develops a model CMOC based on the previously presented information.

The monograph concludes that common elements of doctrine, and each of the three operations can produce a model CMOC which can be helpful in writing more detailed doctrine on the subject.

## TABLE OF CONTENTS

I. Introduction.....	1
II. The Nature of Humanitarian Organizations.....	4
III. Current Doctrine.....	13
IV. Recent Operaitons Employing a CMOC.....	35
V. Threads of Continuity.....	51
VI. A Model CMOC.....	53
VII. Summary, Conclusion, and Recommendations.....	62
Endnotes.....	67
Annex A: Principles of Humanitarian Action in Armed Conflict.....	73
Annex B: NGO Operations.....	74
Glossary.....	75
Bibliography.....	78

## INTRODUCTION

In recent U.S. Military Operations Other Than War (MOOTW), a new adjunct to traditional command and control organization has evolved: the Civil Military Operations Center (CMOC). The CMOC is a facility where representatives from nongovernmental organizations (NGOs), private voluntary organizations (PVOs), and others can meet to coordinate their activities as they relate to serving the indigenous population in a theater of operations. The study of this new facility, unfamiliar to many Army officers in the past, is now relevant for many reasons. Since Operation Provide Comfort in northern Iraq, where the idea first originated, all U.S. operations have fielded some form of a CMOC.<sup>1</sup> This is due to the realization that during MOOTW, specifically that of Humanitarian Assistance (HA), NGOs are providing supplies and services which can potentially contribute to the overall military mission. In the execution of the U.S. National Security Strategy of Engagement and Enlargement, U.S. forces will likely continue this practice as nongovernmental organizations are thousands strong and continue to proliferate.<sup>2</sup> It is significant to note that these organizations are normally operating before U.S. forces arrive in theater and remain after the military redeploys; they long have been part of the Third World environment; an environment in which the U.S. operates with increasing frequency.<sup>3</sup> Doctrine pertinent to the CMOC is still emerging; some information is available in U.S. Army and Joint publications, but it is far from adequate. What is important however is the fact that unity of effort is firmly established as a fundamental principle of MOOTW.<sup>4</sup> This principle gives commanders and staffs the doctrinal basis for incorporating the CMOC as an integral component to their operation. The unity of effort derived from Civil-Military Operations (CMO) in recent JCS and UN operations has proven to be a force multiplier and resource saver for military commanders. In this light the CMOC has become an object of increasing interest as the U.S. Army faces an uncertain and challenging 21st Century which promises no shortage of MOOTW.

## RESEARCH QUESTION

The research question of this monograph is as follows: Given the experience of recent U.S. operations employing a CMOC, what is the best model for this mission enhancing organization?

## METHODOLOGY

This study begins with definitions of the civil military operations center, nongovernmental organizations, and private voluntary organizations. These terms are perhaps new to some, and are important for a critical review of doctrine and experience in this area. The next step in examining the evolution of the civil military operations center is to learn more about the organizations that will frequent the CMOC for assistance from the military. Understanding the culture of NGOs and PVOs will drive the component parts of the CMOC, its functions, procedures, and aid in developing a realistic expectation of what the CMOC can do and what it cannot do. The monograph will then review current military doctrine as it pertains to the CMOC. Following the doctrinal review, three recent operations will be examined in terms of how the CMOC was employed. The three operations are: Operation Restore Hope, Somalia; Operation Support Hope, Rwanda; and Operation Uphold Democracy, Haiti. Next, the paper will identify threads of continuity among the three operations. In this way, the desirable attributes of each CMOC can form the basis of a model CMOC. This model could be the basis for a more detailed treatment of the subject in doctrinal publications, or could serve as an object of debate or further research. The paper is finally concluded with further recommendations on the subject.

## SCOPE

The scope of this monograph is limited in several ways. This study traces the evolution of Civil Affairs (CA) operations or doctrine only since the conception of the CMOC (as it is generally understood today) during Operation Provide Comfort in Iraq. While many other military operations involving CMOCs have been executed since 1991, only the three mentioned above will be examined in detail. The amount of published information available concerning CMOCs in

Somalia, Rwanda, and Haiti is limited, but fortunately officers who served in these deployments are available for interview. This paper will not go into great detail as to the level of command one might find a CMOC and the differences inherent therein, but will concentrate more on generic functions, procedures, components, and capabilities common to the CMOC at any level. The review of pertinent doctrine is also limited in scope to Joint and U.S. Army publications. This is because the preponderance of CA assets in Department of Defense (DoD) come from the U.S. Army. There is some doctrine in the CA arena in Air Force, Navy, and Marine publications, but no substantive information there relates to the civil military operations center. The study will briefly address issues concerning the unique force structure of CA units with respect to active versus reserve component. The recommendations section at the end of the paper will address specific areas which need further study by DoD.

#### DEFINITIONS

Central to the discussion of the Civil Military Operations Center is a sound definition of what a CMOC is and that of its reason for existence -- the NGOs/PVOs. Establishing a definition of these terms early in the paper serves to assist the reader with relatively new terms to the military lexicon, forms the basis for the discussion in this monograph, and helps avoid confusion later when discussing recent operations where different terms were used instead of CMOC.

Although one can find descriptions of what a CMOC is in doctrinal publications, the best definition is found in the U.S. Army John F. Kennedy Special Warfare Center and School (USAJFKSWCS) White Paper Civil-Military Operations Staff Support to Army Corps and Division G5 Sections:

The CMOC is hereafter defined as a coordination center established and tailored to assist the unit CMO [civil military operations] officer in anticipating, facilitating, coordinating, and orchestrating those CM functions and activities pertaining to the civil population, government, and economy in areas where armed forces, GOs [government organizations], IOs [international organizations], NGOs, and PVOs are employed.<sup>5</sup>

The definitions for nongovernmental organizations and private voluntary organizations vary from source to source. Joint Pub 3-07, Joint Doctrine for Military Operations Other Than War, provides a concise definition and, owing to the recency of its publication, is perhaps the most definitive:

**nongovernmental organizations.** Refers to transnational organizations of private citizens that maintain a consultative status with the Economic and Social Council of the United Nations. Nongovernmental organizations may be professional associations, foundation, multinational businesses or simply groups with a common interest in humanitarian assistance activities (development and relief). “Nongovernmental organizations” is a term normally used by non-US organizations. Also called NGO. (Approved for inclusion in the next edition of Joint Pub 1-02)

**private voluntary organizations.** Private, nonprofit humanitarian assistance organizations involved in development and relief activities. Private voluntary organizations are normally US-based. “Private voluntary organization” is often used synonymously with the term “nongovernmental organization.” Also called PVO. (Approved for inclusion in the next edition of Joint Pub 1-02)<sup>6</sup>

A detailed discussion of the doctrine pertinent to the CMOC follows the next section of the paper, which is an in-depth look at NGOs, PVOs, and other humanitarian organizations.

#### THE NATURE OF HUMANITARIAN ORGANIZATIONS

Given that the main purpose of the CMOC is to provide a place for IOs, GOs, NGOs, and PVOs, to meet, share information, and request assistance, then it is important to know the culture of these organizations. A better understanding of these organizations will not only improve communications with them, but will also affect how the CMOC is established, where it is located, and how it works. The discussion of these organizations will center on answering these questions: Who are these organizations? What do they do? How do they relate to 1) their target audience (the population at risk), 2) their supporters and the media, 3) each other, and 4) the military. Knowing

the answers to these questions will greatly assist in designing a CMOC, and integrating the activities of humanitarian organizations into the overall military scheme.

In attempting to establish who these organizations are, the first task will be to classify them into four broad categories: international organizations (IOs), governmental organizations (GOs), nongovernmental organizations (NGOs), and private voluntary organizations (PVOs). Much of the literature concerning humanitarian organizations (including IOs, GOs, NGOs, and PVOs) often uses the acronym NGO to mean any and all organizations connected with humanitarian activity. Once the distinctions between these terms is explained in the next paragraph, this monograph will also use NGO in a collective sense for simplicity.

International organizations (IOs) are generally considered to include the International Committee of the Red Cross (ICRC), and the organizations of the United Nations such as the United Nations Office of the High Commissioner for Refugees (UNHCR), the World Food Program (WFP), the United Nations Children's Fund (UNICEF), and the United Nations Development Program (UNDP). These four UN organizations do not follow a hierarchical structure and operate for the most part autonomously.<sup>7</sup> The ICRC is an international organization, but it actually falls in a class by itself. The ICRC was first founded in 1863 and has an international mandate under the Geneva Conventions of 1949 and 1977. Given its 6300 employees, and \$608 million budget, the ICRC is extremely capable and able to maintain absolute political neutrality.<sup>8</sup> These are but a few examples of international organizations. Other organizations, such as InterAction are also sometimes included in this category.<sup>9</sup>

The next category of organizations to be examined is governmental organizations (GOs). The United States Government may have several organizations involved in humanitarian assistance efforts both at home and abroad. In the case of overseas operations, the State Department is normally a lead player. Ambassadors Embassy staffs and country teams play an important role providing not only extensive in-country experience, but more importantly, they control all U.S.

Government elements in country. Additionally, some countries have an office of the United States Information Agency (USIA), a permanent, in-country asset, which is valuable in providing information to U.S. forces before they deploy and once they are in theater. In terms of humanitarian assistance, the United States Agency for International Development (USAID) is the largest U.S. bureaucracy and is therefore a key organization in most humanitarian operations and can be expected to participate in any CMOC forum. A subordinate organization to USAID is the United States Aid Office for Foreign Disaster Assistance (USAOFDA) which focuses on prompt nonmilitary relief to foreign disasters. In cases of domestic disasters, the Federal Emergency Management Agency (FEMA) is in charge of a different cast of players which could include federal (including DoD), state, and local organizations.<sup>10</sup>

The term nongovernmental organization (NGO) is used in many articles to include all humanitarian relief organizations not affiliated with either the United Nations or the government of a particular nation-state. In its narrower use, NGO refers to European or non-U.S. based organizations.<sup>11</sup> Some doctrinal publications distinguish between NGOs and PVOs based on whether or not the organization has a "consultive" status with the Economic and Social Council (ESC) of the United Nations.<sup>12</sup> Examples of NGOs are Cooperative for American Relief Everywhere (CARE), Catholic Relief Services (CRS), and Medecins Sans Frontieres (Doctors Without Borders) (MSF). According to one recent article, there are some 14, 500 NGOs.<sup>13</sup>

The term private voluntary organization (PVO) is used in some sources to mean U.S.-based organizations or those without any connection to the Economic and Social Council of the United Nations. In the narrowest use of the term then a PVO would be a U.S.-based organization without consultive status to the ESC of the UN. American PVOs are also extensive. They employ hundreds of thousands of people throughout the world with private revenue of \$4 billion and receive \$1.5 billion from USAID.<sup>14</sup> Used synonymously with NGO it could mean any

organization not directly affiliated with the government of a nation-state or an organization of the United Nations.

In the 90s, perceptions of stereotypes abound in both military and nongovernmental camps. Jonathan Dworken's observations from Somalia hold that "many military officers viewed them as politically liberal and often anti-military...young, over-educated, self-righteous, incompetent, expatriated cowboys," while the NGOs saw the military as inflexible and bureaucratic.<sup>15</sup> Taken further, Balbeer Sihra writes in the Marine Corps Gazette that NGOs think the military "would rather use force than save lives" and that NGOs "have unrealistic expectations about what the military can do, such as running all the 'bad guys' away, disarming the populace, and responding to a constant stream of transportation requests" and "presume the military is there to serve their every need."<sup>16</sup> While these stereotypes probably have some basis in truth, misperceptions prevail principally because of a lack of understanding of each others missions, capabilities, limitations, and expectations. Thus the CMOC becomes the harmonizer of diverse capabilities, agendas, and purposes.

The next step in understanding these organizations is in answering the question "What do they do?" Functionally, NGOs might fall into one or more of the following categories:

- Relief (immediate) - emergency medical, food and shelter programs.
- Assistance (short-term) - provide equipment and supplies.
- Development (long-term) - create/improve infrastructure.
- Monitoring - publicize compliance with treaties, agreements, and expectations.<sup>17</sup>

Andrew Natsios believes that nearly all PVOs are devoted to "sustainable development" in the country where they operate and are averse to quick fixes which they believe the military emphasizes.<sup>18</sup> The military does tend to want to accomplish its missions as quickly as possible so it can shift and handle other pressing commitments. A viable effort by NGOs can be the ticket to redeployment. Considering the large number of NGOs and the resources available to them (for

example the dollar figures mentioned earlier), these organizations greatly decrease the burden on the military and U.S. taxpayers when the government decides to deploy forces abroad. For the reasons stated, the military should logically attempt to harness the beneficial effects of NGO activity in the theater of operations.

The next question to answer in the examination of NGOs is “How do they relate to the people they serve, their supporters and the media, each other, and the military?” In dealing first with how NGOs relate to the people they are trying to help, one must understand the principles of humanitarian action delineated in Annex A. These principles guide NGO thinking and conduct while assisting the population at risk. A range of NGO conduct will now be developed (from idealistic to realistic) giving examples of NGO relations with the population at risk to illustrate the realities these organizations face, and the fact that they are very different from one another.

Traditionally, humanitarian organizations have felt protected in hostile situations due simply to the fact that they were there to help the suffering and not to take sides.<sup>19</sup> Many NGOs feel that if they cooperate with the military, they may be associated with the military, one particular faction or country, or be perceived as an instrument of some country’s (or the UN’s) foreign policy.<sup>20</sup> These idealistic principles of well intentioned humanitarian organizations invariably collide with the cruel realities of the post Cold War world:

Indeed, until Somalia the ICRC never employed armed guards or drove in convoys protected by military forces. In fact, it was doctrinal heresy for the ICRC to use force to protect its operations and to work closely with the military in that country. The change was more a function of the chaos in the countryside than deliberate change to ICRC doctrine.<sup>21</sup>

All NGO conduct is not the same; it can vary from helpful and cooperative to blatantly counterproductive. “Faith-based groups may support one community only, raising tensions; conciliation efforts may go awry; some NGOs have even been caught smuggling weapons.”<sup>22</sup>

These negative examples are probably extremely isolated, but compared with the well established doctrine of ICRC, they provide an illustration of how different NGOs can be. The bottom line is that NGOs may at best shy away from the military, and more specifically the CMOC, not because they don't like the military, or because they are uncooperative, but because the principles which guide their actions convince them that they can best serve the population at risk if they remain completely neutral. At worst, they have agendas or practices that are antagonistic to stated U.S. security objectives or the U.S. military mission. Given the diverse nature and ambitions of the expanding list of NGOs, the CMOC is challenged with facilitating unity of effort or at least avoiding collisions of effort/purpose.

An unmistakable reality in a Third World with expanding needs is that the proliferation of NGOs causes competition for scarce dollars. This is a fact which can influence how NGOs relate to their supporters and the media. These next paragraphs will try to explain how NGOs relate to their supporters and the media and how this relationship can effect NGO conduct. NGOs seek to qualify for USAID funds, or want to "keep their distance" from the government, because they may object to some of its policies. The media, in the form of news programs and purchased advertising, are thus critical to generating contributions. The more emotional the images are of disaster areas abroad, the more NGOs stand to round-out their budget. In their competition for contributions, the NGOs must be perceived by the media as providing quality programs, while also keeping their overhead expenses as low as possible since they are supposed to be non-profit organizations.<sup>23</sup> This tension is where the idealistic desire to remain completely neutral breaks down. The NGOs, in spite of their guidelines calling for neutrality, may be drawn to where the media can possibly generate dollars for their cause, even if it means associating with the military or some other actor in theater.

It is the relationship between military, media, and money that provided a unique dynamic which can influence NGO conduct. Not only do military operations draw media attention, but the

military can provide invaluable cost saving as well as life saving services to NGOs. The military can provide transportation and vital security in remote and volatile environments. Furthermore, military presence can provide the perception of legitimacy of on-going activities in the region. The attraction here for NGOs becomes obvious: If the military can provide services to NGOs then the NGOs overhead costs decrease. Combine this with exposure to the media (with the military giving credit to the NGOs where it is due<sup>24</sup>) and the NGOs income increases. It is the awareness and understanding of this dynamic by commanders and civil affairs officers, as well as NGOs, that is key to the success of the CMOC and unity of civil-military effort.

Beyond the relationship just described, it is next the relationship between the NGOs themselves that provides yet another dynamic to be understood in civil-military operations. Literature which addresses how NGOs relate to one another offers a wide range of views perhaps owing to the extreme diversity of the NGOs themselves. One view is that they do not get along:

The complicating subtlety is that many of the institutional players really don't like or trust one another. The PVOs quarrel quietly among themselves, publicly with the UN. The UN does not often deal with the ICRC, which keeps to itself and protects its prerogatives. Much of this distrust is understandable - it results from ambiguous or overlapping organizational mandates; the stresses of working in combat where relief workers regularly get killed, wounded, or kidnapped; competition for scarce private or donor government resources; the lack of experience in dealing with each other; and turf issues over geographic and sectoral focus.<sup>25</sup>

Cooperation does take place among NGOs, and in fact may be more the rule than not, especially in cases where the strengths of one cover the weaknesses of another. InterAction conducted a study in 1987 which focused on why NGOs in seven African countries cooperated or did not cooperate with each other. The study developed many categories of reasons which contributed to NGO behavior in this area. All agreed that any information that an NGO could gain from cooperation was good, that "appropriate" forms of cooperation was an important goal, and that NGOs either consciously or otherwise conduct a cost benefit analysis as to whether or not they cooperate with

other agencies.<sup>26</sup> NGOs can also form vast networks which tie together the efforts of a myriad of donors of both supplies, money, warehouse space, and distribution means.<sup>27</sup> See Annex B. The lesson here is that the personality of NGOs covers a wide range from very cooperative to extremely aloof; from evenhanded to supportive of one or more of the antagonists. For the military, it is in understanding the charter, capabilities and limitations of each NGO and how they will/will not interface with others that CMO are best enhanced. The CRS [Catholic Relief Services] Guidelines on Humanitarian Assistance in Conflict Situations, is a tool which aids the military by providing very specific instructions on when CRS gets involved in relief, to what degree it will cooperate with other agencies, and under what conditions funding will be accepted from other organizations. The thrust of the document seems to allow for a degree of cooperation as long as CRS loses no freedom of action.<sup>28</sup> With this type of understanding, the military must recognize that it cannot treat all NGOs the same if it hopes to achieve unity of effort. The critical task to commanders and staff thus becomes one of taking the time to understand the salient characteristics of the NGOs operating in theater, much as one would try to understand the compatibility/interoperability of military forces or systems.

The last issue in learning about the nature of humanitarian organizations is how the NGOs relate to the military. The rather hierarchical nature of the military, its clear chain of command, and its focus on mission accomplishment is probably foreign to NGOs, who in many cases operate with little interference from their managers and decision-makers who are probably not in the theater of operations. The tension between the military (who may want to “take charge” of the NGOs with the noble intentions of making them work more efficiently) and the NGOs (who want transportation and security without any “hassles”) can only serve to make cooperation difficult. Jonathan Dworken, in a recent article, describes trying to fix this lack of military-NGO command relationship as “trying to put a square peg in a round hole.”<sup>29</sup> In spite of this tension, some NGOs make contact with the military in humanitarian operations. Capitalizing on the experience of those

who do, the military can better understand what attracts NGOs to the CMOC and thereby enhance unity of effort. One example is participation of five NGOs in a Joint Readiness Training Center (JRTC) Peace Enforcement exercise in November 1993. Fortunately, these representatives collectively wrote an after-action review of their experience which acknowledged the importance of cooperation among themselves as well as the military.<sup>30</sup> Additionally, there was NGO involvement in a three-day conference held at the Command and General Staff College, Fort Leavenworth, Kansas which looked into interagency cooperations in peace operations.<sup>31</sup> For the most part, NGOs seek transportation assets and security either in general terms or specifically convoy escorts. These things the military can usually provide. The important point is for both the military and the NGOs to focus on the good that they can do for themselves and each other through cooperation. CMOCs provide the opportunity for this focus and cooperation to take place.

The reality for the foreseeable future is that contact between the U.S. military and NGOs is on the rise as the United States conducts its National Security Strategy of Engagement and Enlargement. The range of NGOs, their competitive nature, methods of operation, altruistic principles, make the goal of unity of effort illusive, but no less important. The lack of understanding and experience among the wide variety of humanitarian organizations and the military drives the commander and his staff in the CMOC to learn the culture of NGOs as a critical aspect of achieving unity of effort and accomplishing the mission in the most efficient manner. Unified operations are even more important to the U.S. military in view of force structure cuts in the face of expanding requirements in a multi-polar world. Knowing the culture of NGOs is the first step to harnessing their capability and harmonizing their diverse capabilities consistent with assigned military objectives.

## CURRENT DOCTRINE

The study now turns to a review of doctrinal publications that pertain to the CMOC. Joint doctrinal publications will be discussed first, followed by service (primarily Army) manuals. These publications represent the applicable military references commanders have had to base CMO on since the end of the Cold War. The rapid increase of civil military operations in the post Cold War era has taxed doctrine to keep pace with operations and field innovation. While the subject of the CMOC is not mentioned in all of the references that follow per se, there are common elements that apply to the CMOC.

Joint Publication 3-07, Joint Doctrine for Military Operations Other Than War, sets forth the basic fundamentals for MOOTW. It explains how MOOTW differ from large scale, sustained combat operations, and addresses different type of operations short of combat, as well as the unique planning considerations that come with MOOTW. This publication is also designed to be a springboard for further publications which will deal with the tactics techniques and procedures of MOOTW in greater detail.

Joint Pub 3-07 places a great deal of emphasis on the need to coordinate with NGOs, the importance of CA units, and the CMOC as a method to build unity of effort. The importance of NGOs as a source of intelligence is also clearly established. The publication introduces the idea of "information gathering" as opposed to intelligence, and the idea that the military needs to be sensitive to the fact that NGOs may not appreciate being used as sources of intelligence.<sup>32</sup> The military should attempt to tap this source of information in a way that does not detract from the primary goal of building unity of effort. This doctrinal publication also highlights the fact that civilian communications in theater may be disrupted. The military should plan for this problem, as well as establishing communications links with agencies from the UN and NGOs.<sup>33</sup> Joint Pub 3-07 states that the Joint Force Commander (JFC) should be prepared to coordinate with civilian agencies and one method is to establish a CMOC. The publication states there is no established

structure for the CMOC, as it should be configured based on the situation. A Handbook for CMOC Operations is cited as being available from USAJFKSWCS, but this book does not exist. Joint Pub 3-07 goes on to state that CA personnel are ideally suited to and trained for CMOC duties and, if possible, agreements with NGOs in the form of memorandums of agreement (MOUs) should be used.<sup>34</sup> The manual briefly touches on the need for legal expertise for CA activities and contingency contracting, the fact that logistics forces may need to redeploy late so they can continue to support NGOs, and that commanders should plan on using U.S. Army Reserve CA units in MOOTW.<sup>35</sup> This manual concisely identifies the importance of NGOs in MOOTW and the means (the CMOC) by which to coordinate their effort.

Joint Publication 3-08, Interagency Coordination During Joint Operations, Working First Draft, provides extensive information on NGOs and the CMOC. Unfortunately there is not wide distribution of this draft, and it is not included in either the Joint Electronic Library CD-ROM or the Joint Electronic Library Peace Operations CD-ROM. This draft manual does an excellent job of describing the characteristics of NGOs, and IOs. Like Joint Pub 3-07, it emphasizes the importance of NGOs as a source of “information” (intelligence) for the commander.<sup>36</sup> It provides exhausting information on how the U.S. Government bureaucracy operates and how it interfaces with the military in MOOTW. For the purpose of this paper, it starts to get at the heart of the CMOC and where it fits in the overall command and control structure of the military.

Joint Pub 3-08 offers good advice on how the military officer may approach the his dealing with NGO personnel:

- (1) Cooperation and synchronization are achieved through consensus building;
- (2) The military officer’s voice is but one among equals - present your views persuasively, not authoritatively, to reach decisions;
- (3) Appreciate and understand the cultural differences among agencies (more on this later); and,
- (4) Upon decision, agreements must be negotiated and reduced to writing as

memoranda of understanding or terms of reference to avoid future misunderstandings.<sup>37</sup>

The last point is perhaps indicative of planning that takes place at higher levels; there may not be a need for an MOU in dealing with each and every NGO or for agreements made on a daily basis. The desire to formalize activity into a "contract" may not sit well with the NGOs and therefore would be counterproductive.

Joint Pub 3-08 provides three terms which describe coordination facilities which have functions similar to the CMOC, but are found at higher levels of command. The first of these is the Humanitarian Assistance Coordination Center (HACC). See Diagram 1. The HACC is designed to assist the CINC. It is a forum where the unified command, agencies of the U.S. Government, and relief organizations can orchestrate operations. A representative from OFDA is seen as a good choice for the director of this effort. The HACC should include representation from the NGO and PVO community, a legal advisor, a public affairs advisor, and a civil affairs officer.<sup>38</sup> The second of these facilities is the Executive Steering Group (ESG). Joint Pub 3-08 offers only a short paragraph on this term and describes it as a tool for the CJTF to exchange information and resolve difficulties. Participants in the ESG are members of the embassy, representation from the NGO community, the JTF, and others as appropriate. The third option available to the CJTF is the fielding of a Humanitarian Operations Center (HOC). The HOC is a policy-making and governing body which develops and monitors the relief strategy. Membership should consist of decision makers, or at least those who have limited authority to commit assets of the organizations they represent. If the operation is connected with the UN, then consideration should be given to UN direction of the HOC. Other members of the HOC could be JTF, DART, NGO, ICRC, and host government representatives.

Diagram 1

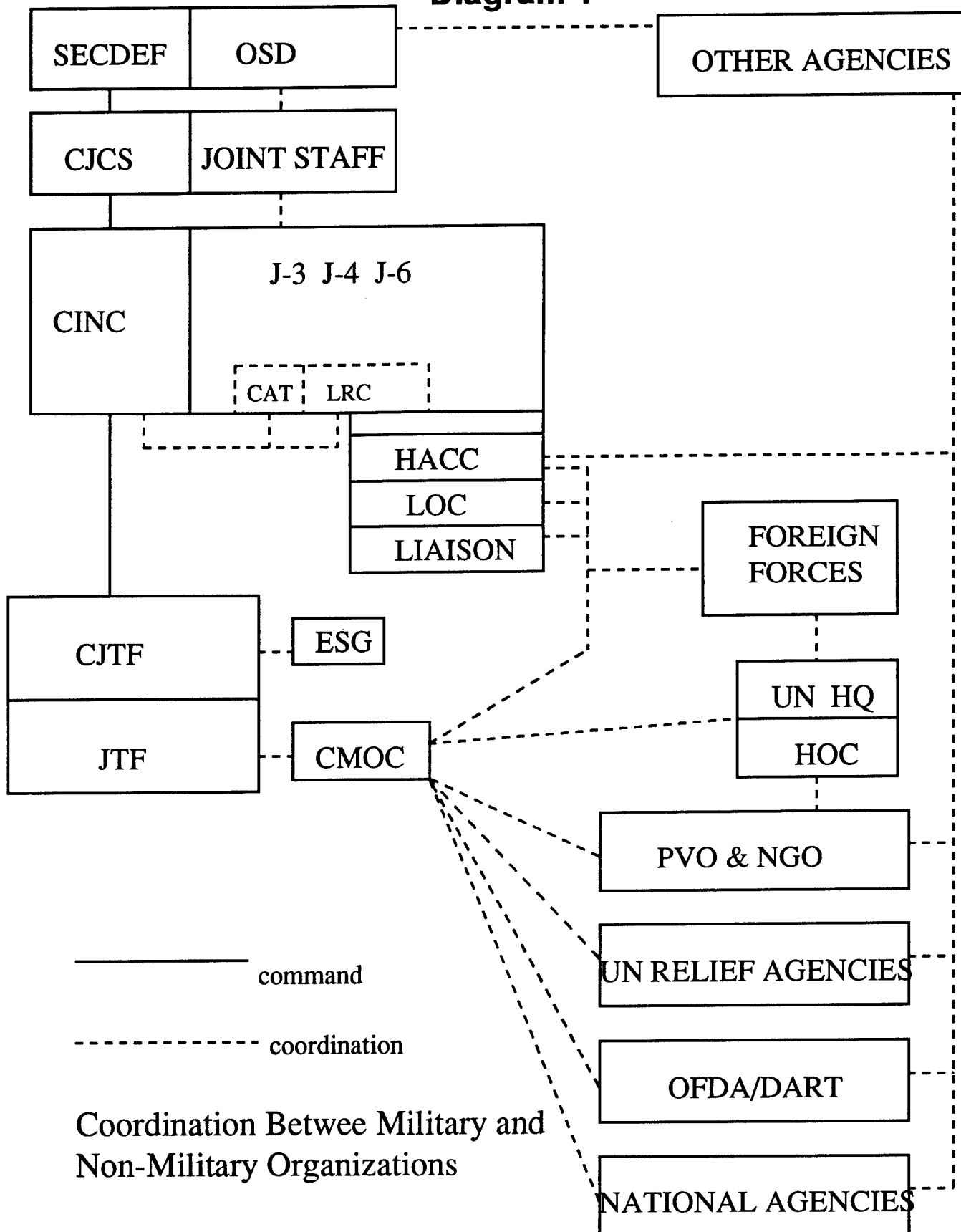

Source: Joint Pub 3-08, Interagency Coordination During Joint Operations, Oct 1994, page IV-12.

The HOC can also function as an intermediary between the HACC and the CMOC. The HOC can evolve into an “international coordination center” if the effort entails coordinating the effort of several nations.<sup>39</sup> Also available to the JTF is the CMOC, a lower level organization than the HACC, ESG, or HOC. The CMOC will be discussed more fully later.

At this point, the number of terms associated with this effort to coordinate nonmilitary organizations becomes unruly. In terms of Joint Pub 3-08, one should remember that the HACC belongs to and advises the CINC. The JTF can create any of the following: an ESG, a HOC, and a CMOC. Given the information available on the ESG, it seems redundant with the term HOC. The language describing the HOC implies that this more of a UN-focused effort, especially since it can evolve into an “international coordination center.” Joint Pub 3-08 attributes functions to the HOC which bypass traditional responsibilities of the J3: “the priorities, objectives, and policies formulated by the HOC are forwarded to the CMOC for coordination and implementation.”<sup>40</sup> This publication seems to be trying to impose and strategic, operational, and tactical order on the effort to coordinate nonmilitary organizations. There may be difficulties in this approach if a dual staff system evolves, or there is insufficient staff on the part of the military or nonmilitary organizations to provide representation at all or any of these facilities. It would be extremely confusing just trying to explain what these committees were to humanitarian organizations.

The CMOC is offered as a facility the JTF may wish to employ to coordinate the efforts of humanitarian organizations. Joint Pub 3-08 briefly describes some of the characteristics of the CMOC employed during Operation Restore Hope. The CMOC enjoyed a status as co-equal to other J-staff sections, it coordinated actions with not only relief organizations, but also U.S. State Department officials, and became the focal point for needs, services, and infrastructure relating to the relief effort. The manual gives nine potential functions of the CMOC:

- Carry out guidance and decisions, frequently developed by the HOC.
- Perform liaison and coordination between the military capabilities and the needs of the NGOs.

- Validates and coordinates requests from the NGOs for military support identified during daily meetings.
- Provides a conduit of information from the JTF to the NGOs.
- Convenes mission planning groups for complicated military missions (e.g. convoy escorts) to support NGOs.
- Report to the JTF on useful information gleaned from normal activities.
- Coordinate public affairs matters.
- Chair port and airfield committee meetings for space and access related issues.
- Facilitate creation and organization of a food logistics system for food relief efforts.

Joint Pub 3-08 then loosely describes the CMOC structure stating that it can be tailored to the specific tasks the situation dictates it must perform. The size may vary, but generally it consists of eight to ten people; the manual offers a diagram for its organization. See Diagrams 2 and 3.

Appendix D of the manual provides a sample matrix for tracking agency capabilities and resources. This section of the manual also cautions against NGOs inadvertently gaining access to classified information when making visits to the CMOC or similar facility the JTF may employ.<sup>41</sup>

Joint Pub 3-08 provides a detailed appendix of NGOs, PVOs, and IOs. This information is not merely a listing of the organizations names, but a detailed description of what they do. For some NGOs there is several pages of information. This type of approach is excellent in terms of military officers attempting to understand their audience in the CMOC - the NGOs. Taken one step further, the CA community could keep this information updated on a semiannual basis in order to stay truly in touch with the NGO community. Joint Publication 3-08, even though only a draft, provides the most detailed information on the CMOC among the joint doctrinal publications. The next doctrinal manual to be reviewed is a joint publication written specifically for civil affairs.

Joint Publication 3-57, Doctrine for Joint Civil Affairs, covers the full range of activities expected of CA assets and offers some introductory level information on the CMOC. The importance of coordination with NGOs and other nonmilitary organizations is found throughout the manual, but information specifically about the CMOC is found in Chapter 4, Organization and

## Diagram 2

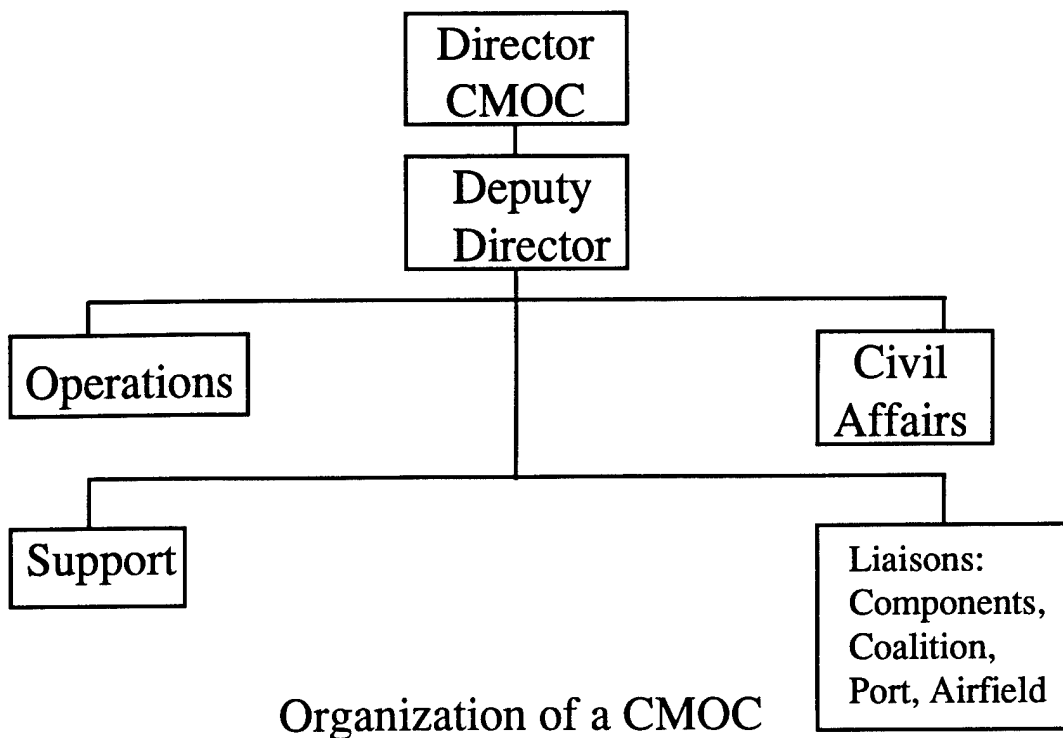

Source: Joint Pub 3-08, Interagency Coordination During Joint Operations, Oct 94, page IV-27

## Diagram 3

### The Role of the CMOC in the Humanitarian Framework

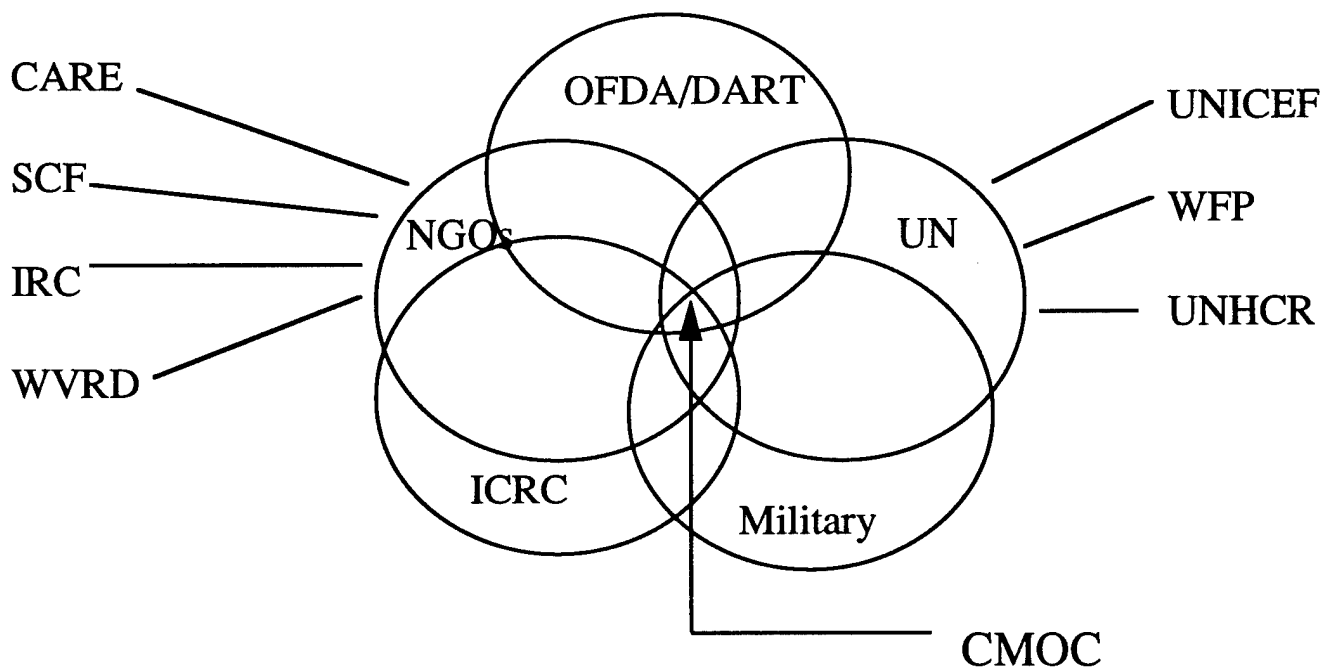

Source: Joint Pub 3-08, Interagency Coordination During Joint Operations, Draft, Oct 1994, page IV-24

Command Relationships. This doctrinal publication offers the CMOC or the Joint Civil Military Operations Task Force (JCMOTF) or both as options to organize civil military operations for combatant commanders, JFC, JFSOCC, service, or functional component commanders.

Interestingly, Joint Pub 3-57 implies that names given to these organizations (CMOC or JCMOTF) are not important. The JCMOTF is “developed to meet a specific CMO contingency mission, supporting humanitarian or nation assistance operations, a theater campaign of limited duration, or a longer duration CMO concurrent with or subsequent to regional or general conflict depending on NCA or theater guidance.”<sup>42</sup> The JCMOTF is expected to perform any or all of the following nine functions:

- provide command and control or direction to host nation advisory, assessment, planning, or assistance provided by the U.S. military.
- Establish multinational and military to civil links to foster unity of effort.
- Conduct coordination and liaison with the host nation, country team, UN, USG, and other agencies.
- Assist in the planning and execution of civil information programs.
- Plan and execute joint and multinational CMO training exercises.
- Allocate resources.
- Advise/assist in strengthening civil infrastructures.
- Identify host nation support, relief, and funding requirements to the CINC, JFC, or USG agencies.
- Advise the CINC or JFC on policy.

The CMOC (which Joint Pub 3-57 states can be part of a JCMOTF) is the commander’s nerve center for coordination with other non-DoD agencies. It is run by CA personnel augmented by other liaison personnel (e.g. DOS, USAID, FEMA). The CMOC functions closely resemble those of the JCMOTF but:

- A CMOC is flexible in size and composition.
- The CMOC is the primary coordinating agency for IOs, NGOs, and USG agencies when DoD is in control of the theater but may support if DOS or other organizations control or share control of the theater.

- The CMOC should help integrate the military into multinational and military-civil partnership efforts.
- The CMOC should include both military and civilian representatives of all organizations contributing to the CMO effort.
- Management of the CMOC can be given to a commander, shared with multinational military forces, or shared with civilian agencies. In a U.S. military-managed CMOC, the J-3 is normally responsible for the CMOC.

Diagrams of the JCMOTF and CMOC are provided in Joint Pub 3-57, but the manual stresses these are examples only. See Diagrams 4 and 5.

The Joint Task Force Commander's Handbook for Peace Operations is a joint publication written for senior commanders about to embark on a peace operation as a JTF commander. The reference is meant to be a resource tool for the commander and his senior staff in conjunction with current joint doctrine on MOOTW. This joint pamphlet was written partially as an attempt to capture the many lessons derived from recent U.S. peace operations. It covers a wide range of subjects to enhance the understanding and planning of Joint Task Forces executing MOOTW and offers a good deal of basic information related to civil military operations and NGOs.

The Joint Task Force Commander's Handbook for Peace Operations places a great deal of emphasis on the importance of humanitarian organizations, CA assets, the CMOC, and the need for unity of effort. This guide offers several comments from senior officers recently involved in MOOTW, to include General Shalikashvili. The executive summary of this publication states that NGOs and other organizations "are a fact of life" and "It is in the best interest of your mission to integrate these organizations or at a minimum be aware of their activities."<sup>43</sup> The CMOC has been extremely useful in integrating and capitalizing on differing expertise and capabilities. The executive summary includes CA personnel in its description of the "first team" who must be key players integrated as part of the JTF commander's immediate staff. Legal personnel must be available and prepared to advise CA personnel, and logistics units must plan on supporting NGOs.<sup>44</sup>

# Joint Civil-Military Operations Task Force (JCMOTF)

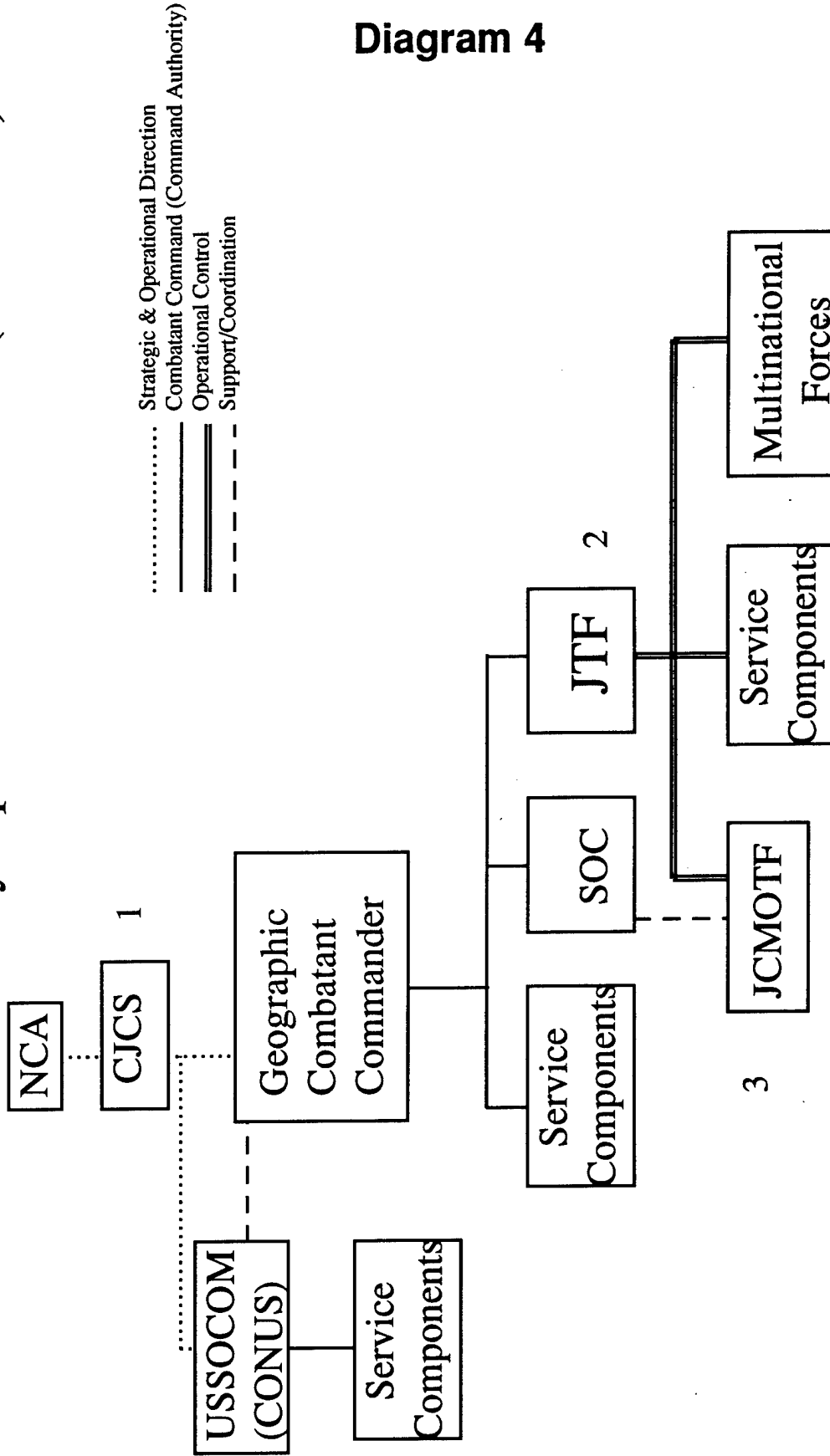

..... Strategic & Operational Direction  
 ————— Combatant Command (Command Authority)  
 = = = = = Operational Control  
 - - - - - Support/Coordination

Diagram 4

1. Combatant commander or joint force commander may maintain direct control of JCMOTF for a specific contingency.
2. Scenario dependent. Combatant commander may direct formation of a JCMOTF in support of other commands as necessary.
3. Liaison with other U.S. Government agencies, host-nation forces, international organizations, NGOs and PVOs as required.

Source: Joint Pub 3-57, Doctrine for Joint Civil Affairs, 21 June 1995, page IV-6

# Civil-Military Operations Center (CMOC)

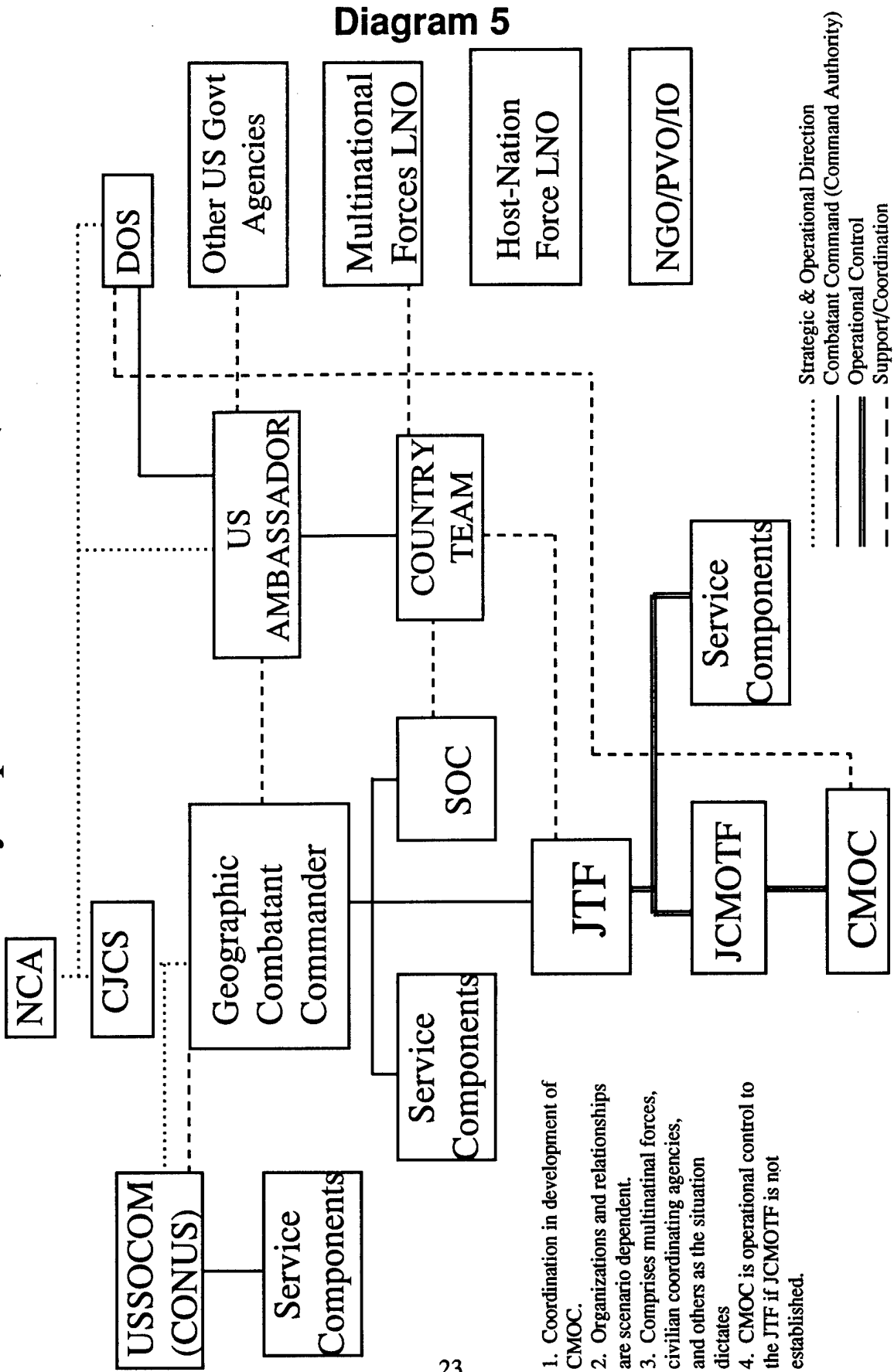

**Diagram 5**

1. Coordination in development of CMOC.
2. Organizations and relationships are scenario dependent.
3. Comprises multinational forces, civilian coordinating agencies, and others as the situation dictates
4. CMOC is operational control to the JTF if JCMOTF is not established.

..... Strategic & Operational Direction  
 ————— Combatant Command (Command Authority)  
 = = = = = Operational Control  
 - - - - - Support/Coordination

Joint Task Force Commander's Handbook for Peace Operations goes into detail about NGOs and PVOs and how they impact in peace operations. The manual explains that the military should try to work with NGOs, and may be able to coordinate their efforts, but will have little control over them. Further, JTF assets can be the lever to facilitate cooperation with NGOs. The handbook clearly tells the JTF commander that he should know the capabilities of these organizations and work with them. The JTF commander is also advised to reinforce a positive attitude among his staff toward NGOs. The handbook recommends a CMOC be established, and gives an example of what a CMOC may look like.<sup>45</sup> See Diagram 6. As with previous joint publications, this pamphlet emphasizes the importance of information gathering by CA personnel from NGOs as this "greatly enhances the overall intelligence effort."<sup>46</sup> If possible, the JTF commander should include NGOs, PVOs, IOs, and governmental organization representatives in planning and training for peace operations.<sup>47</sup> Civil-military communications is also mentioned in that the JTF must plan for including NGOs as part of the overall network to support the operation. This includes planning for frequency management and ensuring compatibility of communication means to ensure the military can communicate with NGOs and UN agencies when necessary. Additionally, the manual stresses the importance of terminology especially as it relates to civilian organizations. Terminology should be developed to ensure maximum understanding by all militaries, NGOs, and other humanitarian organizations. Joint Pub 1-02 and the glossary of the handbook are recommended as a start for a basis of common understanding.<sup>48</sup>

This guide provides a substantial amount of information over a wide range of subjects for the JTF commander to consider. It also provides a good deal of information on the importance of the tone the commanders sets for the staff in dealing with NGOs and the value of CMOC operations in MOOTW. Finally, the reference integrates many of the topics found in other Joint Pubs and therefore also acts as a bibliography for further detail in a specific area.

# Sample Composition of a CMOC

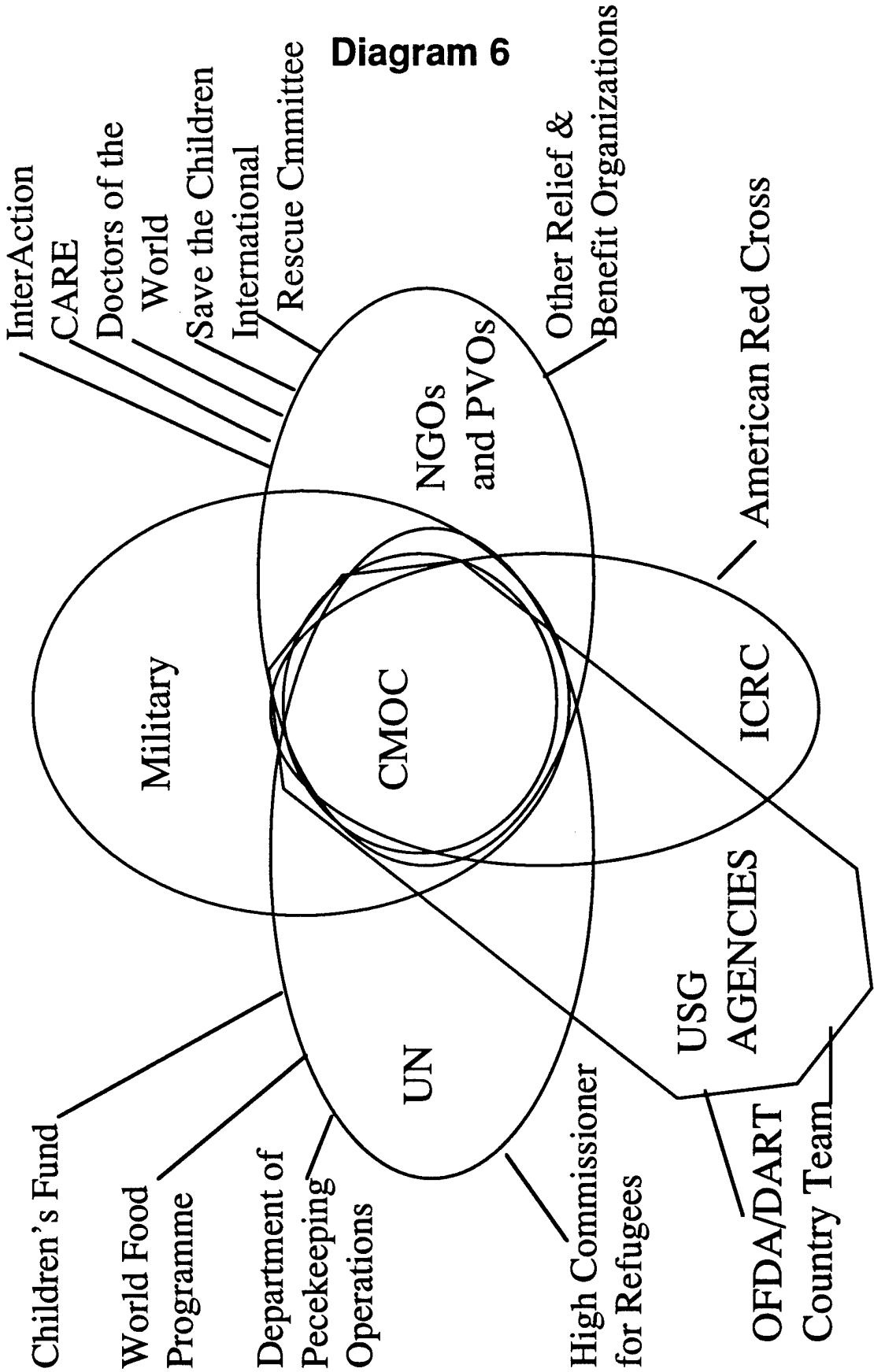

Source: Joint Task Force Commander's Handbook for Peace Operations, 28 Feb 1995, page 23

The next doctrinal manual for review is U.S. Army Field Manual 100-23, Peace Operations. FM 100-23 briefly addresses NGOs and UN organizations as part of the considerations in peace operations. Their value in terms of resources and information is established, as well as the OOTW principle of unity of effort. This manual goes into more detail on explaining the civilian principles of humanitarian action (see Annex A) as it affects NGO willingness to cooperate with the military. A generalized diagram of a CMOC is also provided. See Diagram 7. FM 100-23 also extends the concept of battle command to include the “co-existence of both hierarchical and non-hierarchical organizations . . . in peace operations, both military, interagency, multinational, and NGO.”<sup>49</sup> FM 100-23 also includes some information on international and humanitarian organizations in its appendix B.<sup>50</sup> While the focus of this manual is on peace operations in general, it establishes the importance of unity of effort among non-military organizations, and makes an attempt to provide information to U.S. Army leaders on the nature of NGOs. More detailed information on the CMOC is found in FM 100-23-1.

Field Manual 100-23-1, HA Multiservice Procedures for Humanitarian Assistance Operations, is produced by the Air Land Sea Application Center and pertains to the Army, Marine Corps, Navy, and Air Force. FM 100-23-1 is a tactics, techniques and procedures pamphlet that describes how joint forces conduct humanitarian assistance both domestically and abroad. It focuses on the importance of establishing and maintaining a partnership with governmental organizations, UN organizations, and NGOs.

This Multiservice publication includes a great deal of information found in joint publications, but contains more detailed information relating to the CMOC. The manual begins with definitions including NGO, PVO, and IO. It briefly discusses CA units and indicates that CA personnel normally manage the CMOC.

# Diagram 7

## Civil-Military Operations Center

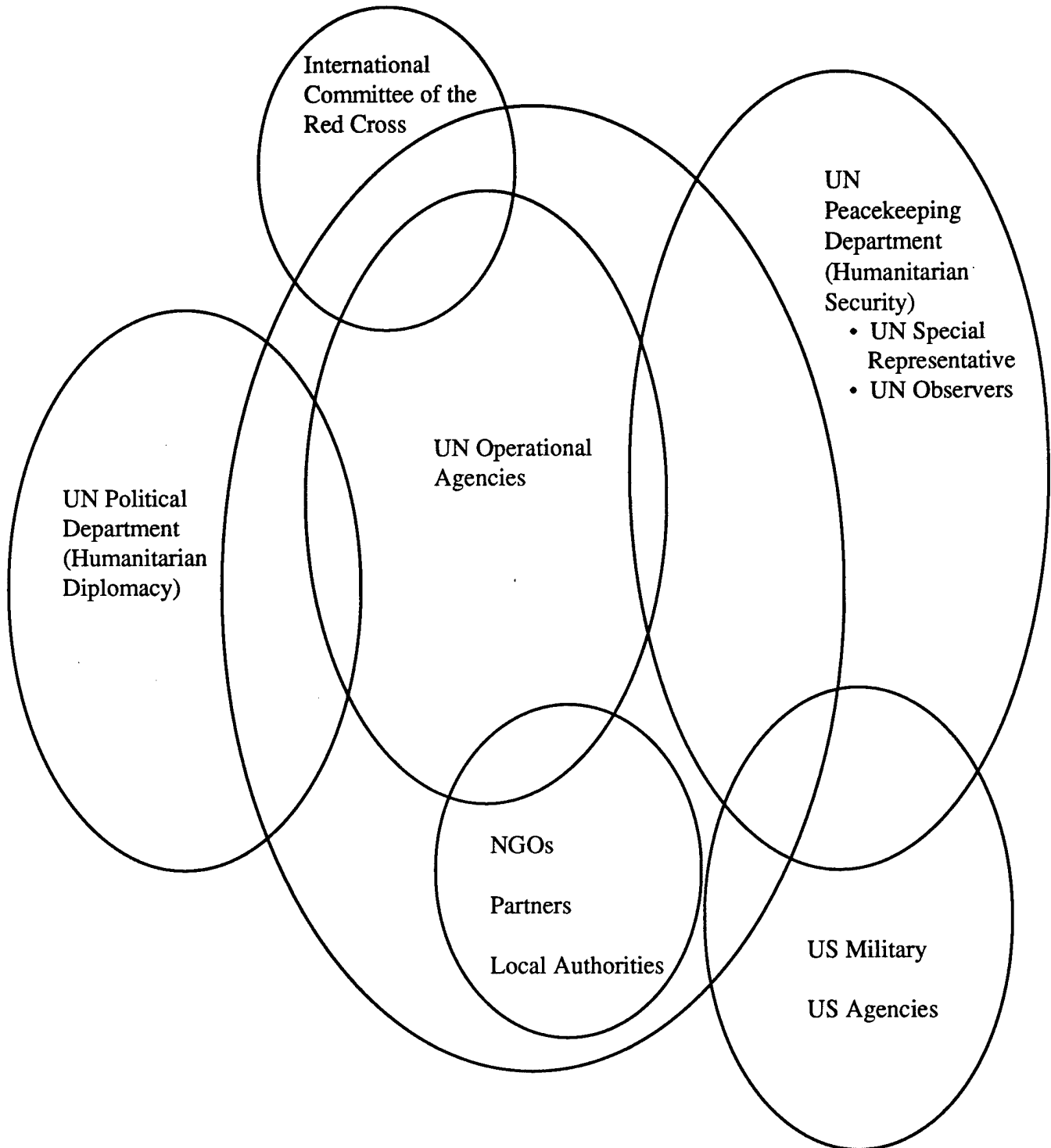

Source: FM 100-23, Peace Operations, Dec 1994, page 27

The manual discusses the nature of NGOs and recommends that the commander use either OFDA personnel or some third party to reach NGOs reluctant to visit the CMOC.<sup>51</sup> Field Manual 100-23-1 offers additional information related to NGOs prior to discussing the CMOC specifically. The military is encouraged to share its various logistical data bases with NGOs and IOs. A list of 30 items one should consider in planning humanitarian operations is provided. Four of these relate to NGOs: consider the communications required to interface with NGOs, recognize the NGOs as a valuable source of information, identify what coordination means are already operating in theater for nonmilitary agencies, and determine which of these organizations the military must coordinate with. See Diagram 8. The manual also suggests organizing humanitarian effort in geographical areas called humanitarian relief sectors (HRS). Considerations for establishing the HRSs, if they are not established before arrival in theater by NGOs already present, are: ethnic and tribal boundaries, political affiliation, or acceptance by the indigenous population to the humanitarian relief effort. The FM also stresses the importance of agency representatives in planning security operations (especially convoys).<sup>52</sup>

Field Manual 100-23-1 continues with information about the humanitarian operations center (HOC), which is essentially a repeat of the information found in Joint Pub 3-08. A couple of points, however, bear mentioning. Discussion of the CMOC begins with a description of this facility as a "tactical" entity which carries out the guidance from the HOC. The manual indicates that the CMOC Director might be the HOC Deputy Director. The number of personnel required for the CMOC is 8 to 12 with the qualification that the composition of the CMOC is situation dependent. See diagrams 9 and 10.

## Diagram 8

### JTF Coordinations

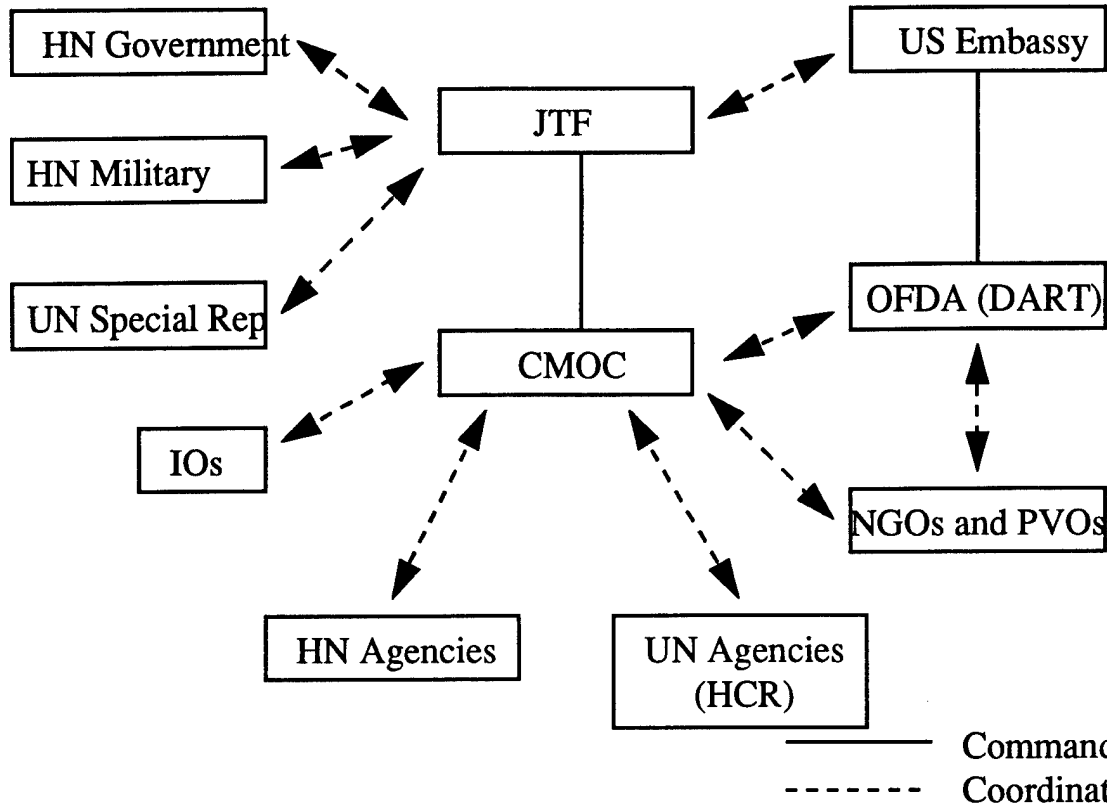

Source: FM 100-23-1, HA Multiservice Procedures for Humanitarian Assistance Operations  
 October, 1994. page 4-13.

**Diagram 9**

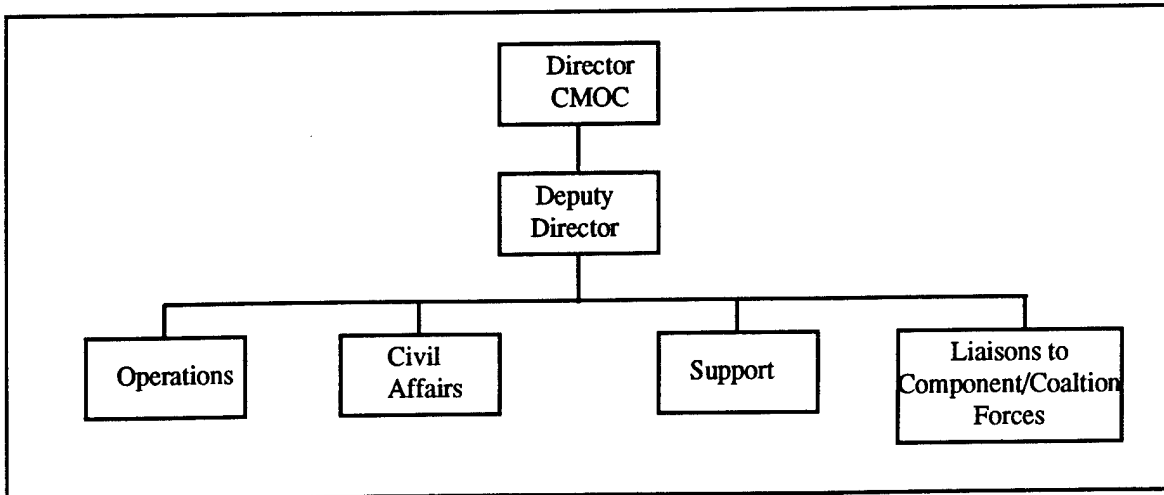

**Diagram 10** CMOC Organization

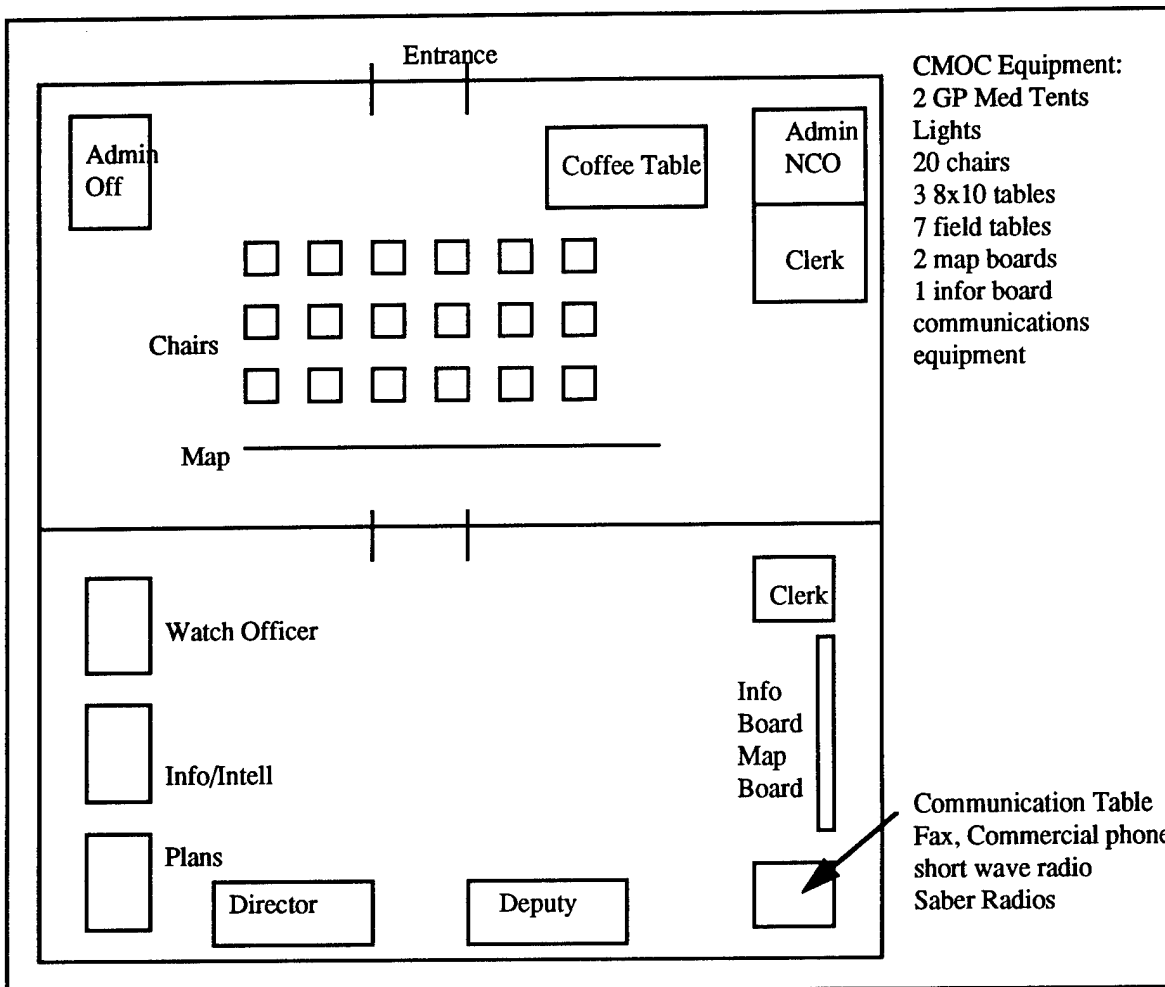

Source: FM 100-23-1, HA Multiservice Procedures for Humanitarian Assistance Operations October, 1994. page 4-17.

The FM recommends daily meetings, and offers a list of functions one might expect the CMOC to perform:

- Validate NGO support requests in the absence of OFDA DART representatives.
- Coordinate military requests among components and NGOs.
- Convene ad hoc mission planning groups.
- Explain JTF policies to NGOs.
- Provide information to the NGOs on JTF security operations.
- Be the focal point for weapons policies.
- Issue NGO identification cards.
- Validate NGOs for military flights.
- Coordinate medical requirements.
- Chair port, airfield, and rail meetings.
- Maintain 24 hours operations.
- Maintain contact with regional and sector CMOCs.
- Support CA teams as required.
- Create food logistics systems.

The manual also provides a detailed description of a support request flow from the NGOs to the CMOC, and to the joint operations center (JOC). The flow follows that described in other manuals, although it provides more detail.<sup>53</sup>

The U.S. Army Field Manual for Civil Affairs Operations, FM 41-10, provides a wide range of information on civil military operations, support to civil administration, and what CA units do. Unfortunately, there is no information in this manual (written in 1993) on the CMOC. Chapter 10 provides some information on the legal aspects of the United States with respect to funding humanitarian assistance. There are a few paragraphs in the back of the FM describing what NGOs are, and a thumbnail sketch of ten humanitarian organizations.<sup>54</sup> This manual does not significantly contribute to the subject of this monograph.

The Army Special Operations Forces have contributed to body of doctrine on the subject of CA and the CMOC in the form of USAJFKSWCS White Papers: Publications 525-5-1, Civil Affairs: A Function of Command, and 525-5-3, Civil-Military Operations Staff Support to Army

Corps and Division G5 Sections. The former publication expands on DoD Directive 2000.13 to establish the idea that civil affairs planning and execution fall within the realm of the commander's responsibilities much the same as the functions of operations, intelligence, logistics, and personnel. The commander needs to consider the impact of civilians on the battlefield as a major factor in planning to include NGOs and PVOs.<sup>55</sup> The latter publication makes the case for the G5 staff officer to be located at the main command post as his duties (just as operations and intelligence) are "outwardly focused" as opposed to combat service support, located in the rear command post which are "inwardly focused." Publication 525-5-3 provides structure for the G5 staff section and also provides details on the CMOC.<sup>56</sup>

Publication 525-5-3 briefly discusses the CMOC operations during Operation Provide Comfort, and mentions Operations Restore Hope, Support Hope, and Uphold Democracy as impetus for the need for doctrine as far as the CMOC is concerned. As far as terminology is concerned, "CMOC" according to this White Paper is understood by hundreds of NGOs who see this coordination facility as their interface with the military unit conducting operations in the AOR. Diagram 11 represents the basic framework Publication 525-5-3 recommends for a CMOC. The diagram corresponds to the minimum personnel the CMOC should have: director, operations officer, administrative/logistics NCO, and organizational representatives. Multiple CMOCs may be required based on distance of different headquarters spread throughout the AOR, a concentration of NGOs, IOs, GOs to a host nation diplomatic center, different levels of command based on geographic location or tactical control measures. Wherever the location or number, the CMOC should be conveniently located for the non-military organizations.<sup>57</sup>

Publication 525-5-3 lists the major functions of the CMOC as follows:

- Provide non-military organizations with a focal point for activities that are related to the civilian populace.
- Provide a coordination center for receiving and answering humanitarian organizations' requests for military assistance. See Diagram 12.

### Diagram 11

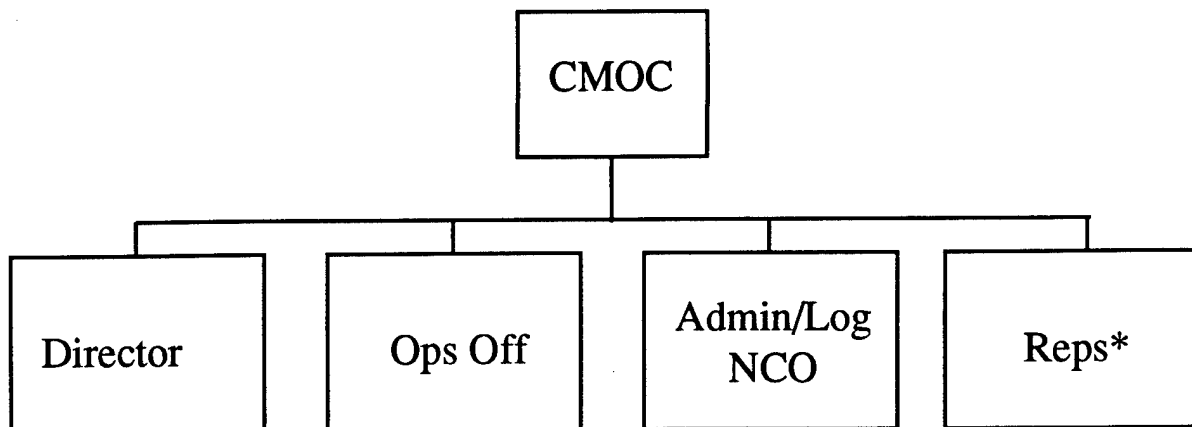

\*Participating or interested representatives from both military (e.g. PSYOP) and nonmilitary organizations (e.g. GO, IO, NGO, and PVO).

Source: USAJFKSWCS Pub 525-5-3, Civil-Military Operations Staff Support to Army Corps and Division G5 Sections, July 1995, page 9

### Diagram 12 Request for Assistance Flow

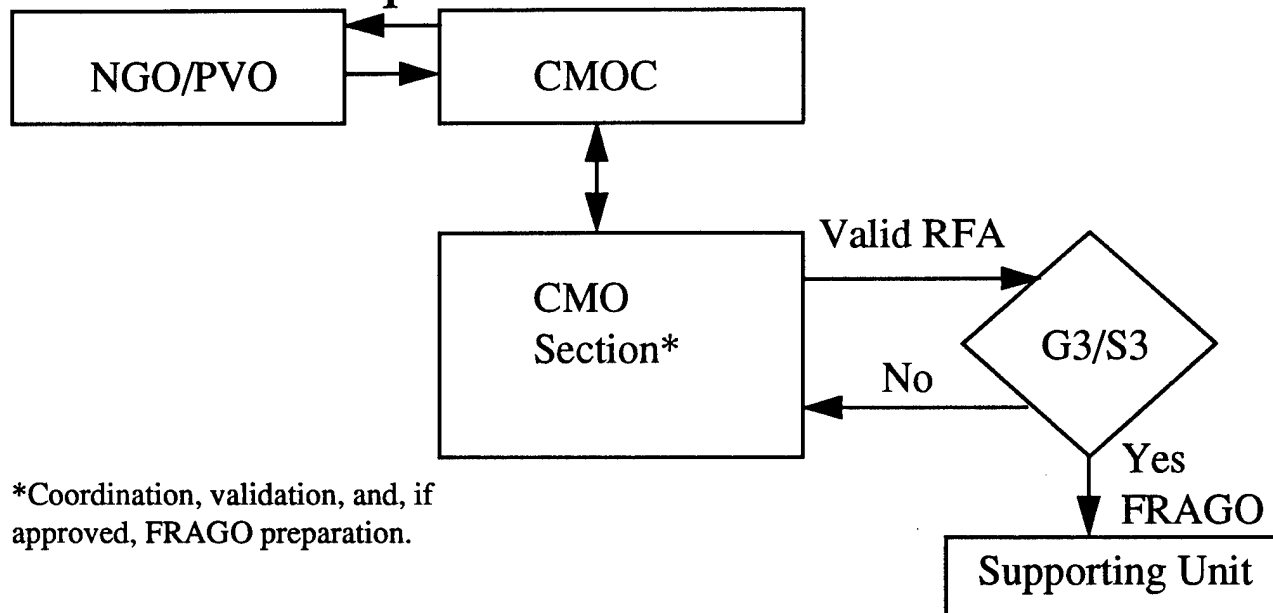

\*Coordination, validation, and, if approved, FRAGO preparation.

Source: USAJFKSWCS Pub 525-5-3, Civil-Military Operations Staff Support to Army Corps and Division G5 Sections, July 1995, page 12

- Exchange information with these organizations.
- Develop synergy among their combined assets.
- Provide interface with USAID and the American Embassy (if applicable).
- Assist in the transfer of authority and/or hand-off of operations from military forces to the host nations, other governmental organizations, IOs, or NGOs.<sup>58</sup>

This publication establishes many of the basic considerations for the CMOC, and defines what the CMOC is regardless of echelon. It forms a good base from which to develop more detailed doctrine. It is also apparent that while this publication tends to use the term CMOC as a generic term which can be used at any level of command above battalion, the joint publications introduce a host of other terms (HACC, HOC, ESG, etc.), which offer shades of meaning based on who attends these fora, and at what level of command they are established.

What is striking about this review of current doctrine is that even though the use of the CMOC is relatively new, there is a good deal of doctrinal information available. Additionally, there is quite a bit of information in doctrine that addresses NGOs. On the other hand, the information from one publication to the next is not always consistent. This leaves the military commander and staff facing the challenge of CMO with the additional challenge of working with somewhat disjointed doctrine that has evolved from different agencies. There are however valuable topical references provided one knows where to look. For basic understanding of the nature of joint operations in MOOTW, and familiarity with NGOs and how they can enhance the military mission, one should consult Joint Pub 3-07, the Joint Task Force Commanders Handbook for Peace Operations, and FM 100-23. Faced with planning MOOTW, and developing an in-depth knowledge of how the CMOC should fit into the overall scheme, one should focus on Joint Pub 3-57, FM 100-23-1 and the USAJFKSWCS White Papers. FM 41-10 provides excellent information on basic Civil Affairs tasks but little on interacting with NGOs or running a CMOC. Quite evident in the review of the doctrinal publications are the numerous terms used to describe CMOC-type operations. The lack of consistency in terminology in and between joint and service

doctrine creates confusion which discourages the military commander looking for clear direction in CMO. These current shortcomings in the evolving doctrine of CMO (and specifically the CMOC) dictate that the commander and staff be current on available doctrine, glean from doctrine the salient points and apply them in a meaningful manner based on the situation they face in order to create effective organizations which are based on the common understanding of their members.

### RECENT OPERATIONS EMPLOYING A CMOC

The monograph now examines three recent operations where some form of a CMOC was used. The three operations are Restore Hope in Somalia, Support Hope in and around Rwanda, and Uphold Democracy in Haiti. Drawing on the experience from these operations, combined with the review of doctrine provided earlier, we can generalize about how a CMOC should be established and operated. The review of these operations will begin with a brief overview of the operation, followed by a look at functions, manning, physical aspects, the doctrine officers consulted, and the relationship of the CMOC to other military staff sections, units, and nonmilitary organizations. Since each of these operations is different, the unique characteristics of the CMOC will also be highlighted in context with the particular circumstances of the AOR.

### SOMALIA

The United States involvement in Somalia can be broken down into three phases: 1) Provide Relief (UNOSOM I) from August 15, 1992 to December 9, 1992; 2) Restore Hope (UNITAF) from December 9, 1992 to May 4, 1993; and 3) USFORSOM (UNOSOM II) from May 4, 1993 to March 31, 1994. The majority of the discussion concerning operations in Somalia will center around Restore Hope (the U.S. effort to bolster UNOSOM I) and Provide Relief which was intended to ensure sufficient food, water, and medicine were transported throughout Somalia, and provide security to ensure the relief supplies did not fall into the hands of clans and warring factions.<sup>59</sup>

The Joint Task Force (JTF) in Somalia organized the relief effort geographically into nine Humanitarian Relief Sectors (HRS) and established Humanitarian Operations Centers (HOCs) for each HRS. Likewise, there was a CMOC for each HOC. The HOCs were directed by officials of UN relief organizations and had representation from the military in the form of the deputy director of the CMOC. The reason for this arrangement was twofold: First, the United Nations organizations were given the task of organizing and conducting most of the relief effort and second, UNITAF wanted to portray the effort in Somalia as primarily UN (the objective was ultimately to give the whole mission back to the UN).<sup>60</sup>

Since the HOCs in Somalia were established by the UN (in Mogadishu) prior to the arrival of the JTF, and were responsible for some of the functions of the CMOC discussed in the doctrine section earlier, more detail will be devoted to the HOC to get a better understanding of the CMOC and the humanitarian relief effort as a whole. The HOC remained under the control of the UN while the CMOC, operating within the HOC was subordinate to the JTF J3. The HOC functions included developing and implementing an overall relief strategy, coordinating logistics for humanitarian relief organizations (HROs), and arranging military support for HROs. As mentioned earlier, the HOC director was a UN official, the deputy director was from DART, and there was representative/liaison personnel from the NGOs. In theory the HOC was to be a policy-making body but it had little real authority.<sup>61</sup> The day-to-day coordination and detail work was left for the CMOC.

The CMOC in Somalia remained the place where NGOs interfaced with the military for information and to submit requests for support. The CMOC was an arm of the JTF J3. It acted as a liaison center and coordination center for the J3 and the HOC. The information on the CMOC that follows pertains to the JTF's main CMOC in Mogadishu (all nine HRS's eventually had their own mini-CMOC). The functions of the CMOC included:

- Validation of requests for military support. These requests included long haul

convoy, security escorts to the interior. Although some requests were sent to the main CMOC in Mogadishu, military support to NGOs in the HRSs was usually the responsibility of the local military commander and his CMOC.

- Coordinating requests for support within the various components of UNITAF.
- Conducting ad hoc mission planning groups as an arm of the UNITAF J-3 for complicated military support or missions involving multiple units.
- Promulgating and explaining UNITAF policies to humanitarian organizations.
- Providing information on UNITAF operations and security situation in daily security meetings.
- Issuing NGO identification cards.
- Validating NGO personnel requests for space available seats on UNITAF aircraft.
- Acting as coordinating agency between UNITAF, NGOs, and UNOSOM headquarters staff.
- Chairing a committee to deal with pier space, port access and related issues important to NGOs.
- Agency for returning weapons confiscated from NGO guards.
- Responding to emergency requests for assistance from NGOs by requesting assistance from the JOC.
- Maintaining and operating 24 hour watch in the CMOC.
- Maintain contact with regional CMOCs.
- Supporting, as requested, a six man Civil Affairs Team.
- Facilitating the creation of a food Logistics System for Somalia.
- Conducting CA assessments.
- Intelligence dissemination.<sup>62</sup>

The function of managing the weapons confiscation program is instructive as it shows how the CMOC was executing a JTF task that directly impacted on NGO operations. The JTF policy of confiscating weapons caused a great deal of problems for the NGOs and the CMOC. In many cases the NGOs hired guards for their personal protection as well as security for warehouses where relief supplies were stored. Additionally, when vehicles were rented in Somalia, they often came with armed drivers. Soldiers manning checkpoints had difficulty differentiating between the guards or were not informed that these people should receive any special dispensation from the weapons confiscation policy. The CMOC wrestled with this problem for some time, and devised

an ID card system which allowed the NGOs' guards to bear arms. The ID card system initially failed because there was no picture on the ID cards, and they were being freely passed to those without authorization. Eventually an enforceable policy evolved that was agreeable to the NGOs, but invariably some soldiers did not get the word, and wrongfully confiscated weapons sometimes took days to be return to their rightful owners. The result was a great deal of frustration on the part of the NGOs and the personnel in the CMOC who were trying to implement a work-around to the JTF policy.<sup>63</sup> This is a good example of how military policies in theater can disrupt NGO activity. The effort by the CMOC to ameliorate the unintended consequences of the weapons confiscation program helped to get NGO humanitarian relief activity back to its previous level.

Manning for the CMOC included two USMC Colonels; one was previously the I MEF Chief of Staff which lent greater credibility to CMOC operations in the eyes of the other JTF staff officers. Manning was as follows:

USMC Colonel	Director
USMC Colonel	Deputy Director
Lieutenant Colonel, SF	Operations
Major, SF	Operations/Plans
Captain, CA	Civil Affairs Officer
Master Sergeant, CA	Operations NCO
Gunnery Sergeant (E7)	Admin NCO
2 Specialists, CA	Admin
2 Specialists, CA	Drivers <sup>64</sup>

The manning represented above shows a mix of CA personnel and non-CA qualified personnel which was effective due primarily to the members ability (personalities) to work with the UN and NGOs. MAJ Nelson indicated that CA personnel are best suited for the task of running a CMOC, but the SF personnel were the best at adapting and relating to the NGOs. The ability to work with civilian organizations (UN, NGOs, USG, etc.) was the most important aspect of personnel qualifications for the CMOC.<sup>65</sup> The cell is small but capable of 24 hour operations. It is important to remember that the HOC, which was operating prior to the arrival of the JTF, composed primarily of civilian representation from US, UN and NGO organizations was

performing a good deal of coordination that otherwise would have fallen to the CMOC to include the coordination of NGO activity in the AOR, and port and airfield management.

The physical aspects of the CMOC in Somalia were that it was co-located in a UN building with the HOC some 2-3 kilometers from the JTF Headquarters. This allowed for easy access for the NGOs and a relatively short distance to the JTF Headquarters. The location of the CMOC was where the NGOs had been used to going --the UN building and the HOC-- so as far as coordination with the NGOs was concerned, this was ideal. Initially, coordination between the CMOC and the JTF J3 was hindered due to communications equipment. The communications problems were quickly solved with UN/NGO lent equipment and more communications equipment capability provided by the U.S. Navy. Since living conditions at the CMOC and HOC in Mogadishu were so much better than those of the JTF, JTF J3 representatives were more than willing to attend the daily meetings at the CMOC/HOC.<sup>66</sup> Important equipment used in the CMOC included communications gear which was compatible with the JTF and cellular world-wide telephones for communication with the NGOs. The NGOs in Somalia relied exclusively on INMARSAT for international communications. With the arrival of the military, competition for satellite time drastically increased resulting in higher cost and recommendations to limit INMARSAT to key users.<sup>67</sup> Vehicles were also identified as critical to the CMOCs mission as they facilitated coordination. In Somalia there were force protection measures which prohibited soldiers from traveling alone. This meant that any task involving wheel transportation required two or more vehicles.<sup>68</sup>

Participants in Operation Restore Hope found doctrine lacking concerning the CMOC: "FM 41-10 is extremely lacking and will be corrected in the next revision regarding command and control issues."<sup>69</sup> Fortunately, there was an effort to capture the lessons of Operation Restore Hope for doctrine concerning humanitarian assistance. MAJ Nelson, operations officer in the CMOC during the operation, was sent to the Air Land Sea Application Center to write two chapters

for FM 100-23-1, HA Multiservice Procedures for Humanitarian Assistance Operations following his return from Somalia. He states that FM 41-10 was “all they had” to look for doctrine on the subject. Specifically, FM 41-10 did not provide any information on the structure of a CMOC, its functions, or any useful information in coordinating with NGOs. The focus of FM 41-10 was too much on Nation Building, shadow governments and displaced civilians.<sup>70</sup> Many of the officers who participated in Operation Provide Comfort were available for Restore Hope; this allowed for a carry-over of experience to make up for the gaps in doctrine.

The relationship of the CMOC to other elements of the JTF was sometimes strained. Petty jealousies existed among the staff officers and many Marine Forces (MARFOR) and UNITAF officers accused the CMOC officers of having been co-opted by the NGOs.<sup>71</sup> This was due to two factors: 1) the living conditions at the CMOC/HOC were much better than those at the JTF, and 2) MOOTW, CMOCs, and dealing with the UN and NGOs was new to most in the military, and any associations with these civilians was bound to create some misunderstanding.

To summarize CMOC operations in Somalia, the JTF recognized the importance of working with the NGOs and made the HOC/CMOC combination the centerpiece for coordination of humanitarian relief in the HRSs. The HOC, already established and operational under UN direction was able to coordinate its requirements for military assistance through the CMOC which was at the same location. The military community also recognized the importance of capturing this experience especially in terms of sending one of the key participants in the CMOC operations in Somalia to assist in writing FM 100-23-1. The CMOC in Somalia was a success.

#### RWANDA

A plane crash on April 6, 1994, resulting in the deaths of the presidents of Rwanda and Burundi sparked a war between the tribes of the Tutsis and the Hutus which in turn started a flow of more than a million refugees into the surrounding countries of Zaire, Uganda, Tanzania, Burundi, and all of Rwanda. By July 14th, the refugee crisis had reached what many described as

“Biblical Proportions” prompting President Clinton to direct USCINCEUR to deploy a JTF in support of humanitarian assistance operations already underway under the auspices of UNHCR. Deployment of military capability began on July 22d and was completed by August 3d. JTF Support Hope focused on the theme “Stop the Dying” which resulted primarily from cholera and dysentery that quickly spread through the masses of refugees. The mission of the JTF was as follows:

JTF Support Hope provides assistance to humanitarian agencies and third nation forces conducting relief operations in theater to alleviate the immediate suffering of Rwandan refugees, to include:

- Establish and operate water distribution and purification systems in Goma.
- Establish airhead and cargo distribution capability at Entebbe.
- Provide 24 hour airfield services at Goma, Kigali, and other sites.
- Establish logistics management in support of UN and other nations.
- Protect the force.<sup>72</sup>

By September 28, the crisis was under control and the capabilities of the NGOs in theater were sufficient to meet the remaining humanitarian relief requirements.<sup>73</sup>

There were three CMOCs established during Operation Support Hope: Entebbe, Kigali, and Goma. The CMOC in Entebbe was co-located with the JTF Support Hope Headquarters. This CMOC focused its efforts on supporting the UNHCR and coordinating strategic and theater airlift. The CMOC in Kigali was focused on humanitarian assistance for all of Rwanda and supported the Department of Humanitarian Affairs/United Nations Rwanda Emergency Office (DHA/UNREO) requirements. The Goma CMOC supported UNHCR requirements and focused primarily on clean water production and distribution and military engineer assets for refugee camps. All three CMOCs supported UN organizations, and coordinated support for NGOs. The CMOCs in Entebbe and Kigali, were directly subordinate to the JTF Support Hope Commander. The Goma CMOC, a more limited operation, was subordinate to JTF A one of the two subordinate JTFs to JTF Support Hope. Taskings in each case would be received by the CMOC and be sent to

the JTF for tasking. The CMOCs would have to provide the JTF with information on ongoing activities and would have to follow-up to ensure that tasking sent to the JTF were acted on and accomplished or if disapproved, for what reason.<sup>74</sup>

Functions common to all CMOCs in this operation were as follows:

- Promulgated and explained JTF policies to UN/NGOs/IOs.
- Provided information on JTF operations and general security operations to UN/NGOs/IOs.
- In coordination with DART, received, validated, and processed UN/NGO/IO's requests for military support. Followed-up to ensure that requests were completed.
- Convened and hosted ad hoc mission planning groups for complex military support requests with UN/NGO/IOs.
- Represented the JTF in various UN hosted fora and meetings.
- Maintained contact/coordination with lateral CMOCs.

Functions specific to the CMOC in Entebbe included the establishment of a combined CMOC/UNHCR logistics cell that facilitated the screening and processing of intra-theater requests for U.S. military airlift and data tracking and analysis for the COMJTF with management information to assist in decision-making. Functions specific to the CMOC in Kigali included:

- Advised and coordinated with the UNREO's On-Site Operations Coordinating Center (OSOCC)
- Established a special UNREO logistics cell to provide NGOs a single point of contact for supplies, material, and transportation.
- Assisted the UN World Food Program in warehouse management, inventory control, and truck assessment control.
- Coordinated with OFDA/DART personnel.<sup>75</sup>

Based on such a wide range of tasks the CMOCs accomplished, it becomes clear that the CMOC in this operation was critical to the success of JTF Support Hope, and a driving force in the ability of the JTF to transfer the remainder of the humanitarian requirements to the UN and nongovernmental organizations.

The manning for CMOC operations in and around Rwanda was composed of an even mix of Reserve Component and Active Duty CA personnel. The initial CMOC effort consisted of two officers from the U.S. Army Peacekeeping Institute in Carlisle, Pennsylvania. The deployment of CA soldiers was delayed for three weeks. "We were prepared to deploy from the start and to this day, I am uncertain why we did not."<sup>76</sup> Another officer deployed to Operation Support Hope explains his impression of the reason for the delay. "It took COL Farris a little time to convince LTG Schroeder that the RC CA guys would be of real value. Once he was convinced, and we were on the TPDFD, and Air Force O-5 at the JTF rear in Germany kept bumping us because 'she knew that the CA folks were a follow-on element' and couldn't possibly be needed now."<sup>77</sup> The number of personnel working at the CMOCs varied throughout the operation (only a few in the beginning and near the end of JTF's mission). During the height of operations, at Entebbe there were ten soldiers working in the CMOC (2 LTCs, 2 MAJs, 1 USN LT CDR, 1 1LT, 1 MSG, 2 SFCs, and 1 SGT); at Kigali there were eight (1 LTC, 1 CPT, 1 1LT, 1 MSG, 2 SFCs, 1 SSG, 1 SGT) and there were three personnel in the CMOC at Goma for a short time. A CA colonel traveled between the CMOCs to provide overall supervision for CA activities in the AOR.<sup>78</sup>

The 50/50 AC/RC mix according to one officer, was directed by the leadership in USASOC. When asked if this mix was advantageous, he stated that while the unique characteristics of the 96th CA soldiers was helpful, it would have been more helpful to choose individuals with the right qualifications instead of specifying a ratio of AC to RC CA personnel.<sup>79</sup> Colonel Karl Farris points out that those CA personnel with prior experience working in a CMOC should be identified to be in charge of the CMOC, and if all members of the CMOC can't be those with prior experience, then at a minimum they must all receive some training related to serving in a CMOC.<sup>80</sup>

The discussion of CMOC operations during Operation Support Hope will now focus on the physical aspects such as location and equipment. The CMOC in Entebbe was located at the JTF headquarters. This location was optimal in that it facilitated coordination with the JTF, and it was also the point where most humanitarian relief supplies and organizations entered the AOR via strategic airlift. The other major CMOC operation was in Kigali Rwanda. Once secured, this location was the center of the relief effort in Rwanda due not only to its airfield, but also due to the road network that radiated from the city. The trip from Entebbe to Kigali was about an hour by C-130. The CMOC in Kigali was initially located at the U.S. Embassy, but was relocated so it could operate as part of the UNREO's OSOCC. The combination of the CMOC and the OSOCC gave the OSOCC the expertise and depth of personnel for it to succeed and further reinforced unity of effort with the UN and NGOs present in Rwanda. Both CMOCs experienced shortfalls in computer and communication equipment, but were able to use some of the equipment brought by the DART team and UNREO. Vehicles were critical for coordination in the Kigali operation. Again, to meet the CMOCs needs for transportation, vehicles were borrowed from the Embassy staff. Interestingly, CA NCOs shipped mountain bikes in the trailers of the unit's two HMWWVs which proved helpful.<sup>81</sup> While the experience of Somalia had indicated the need to plan for and deploy sufficient vehicles, communication hardware, and other equipment, the same shortfalls were experienced in Rwanda.

The U.S. military presence in Kigali resulted in an increased feeling of security among UN organizations and the NGOs. The number of NGOs grew from seven to well over a hundred in a very short period of time.<sup>82</sup> This event brought the focus of effort into Rwanda and accelerated the relief effort. Officers at both the Kigali and Entebbe CMOCs indicate that the JTF staff did not fully appreciate how the CMOCs were contributing to the overall humanitarian relief effort, but were overly concerned with force protection, redeployment, and situation reports.<sup>83</sup> Some of these misperceptions are unavoidable, but may have been exacerbated by the late deployment of

CA personnel.

Doctrine used during the planning and execution of CMOC operations in the JTF Support Hope AOR included FM 100-XX [which is now FM 100-23-1], HA Multiservice Procedures for Humanitarian Assistance Operations, Final Draft March 1994, and FM 41-10, Civil Affairs Operations. The U.S. Army Peacekeeping Institute After Action Review indicated that the CMOCs were established along the principles of FM 100-XX which was written shortly after Operation Restore Hope, Somalia. LTC Fred Jones, director of the CMOC at Kigali, indicated that the experience of the officers serving in the CMOC had a greater bearing on their accomplishments.<sup>84</sup>

To summarize CMOC activity during Operation Support Hope, the military capitalized on its lessons from Somalia in the form of FM 100-23-1. CMOC operations, although slow in getting established, were effective. The flexible employment of CMOCs where they were needed, and the realization of the JTF leadership that the military was necessary only as far as the UN NGO capability were lacking resulted in a relatively short deployment. The late deployment of CA personnel was a mistake, which can only be remedied through a better awareness of senior leaders of the importance of CA personnel as a force-multiplier -- especially in MOOTW.

#### HAITI

Operation Uphold Democracy is different than Support Hope and Restore Hope in that humanitarian activity, and support to NGOs was not a primary focus of the military forces deployed, but more of a supporting effort. The U.S. intervention in Haiti was the result of a chain of events which started with a coup, September 30, 1991, led by LTG Raoul Cedras to oust the democratically elected Jean-Bertrand Aristide. The Cedras ruled Haiti was marked by violence, economic misery, and international isolation.<sup>85</sup> Events in Haiti only worsened in spite of efforts by the U.S. and the UN to get Cedras to transition once again to a democratic state. Efforts by former President Carter on September 19, 1994 averted an invasion of Haiti by a U.S. led

multinational force instead, the force was landed in a permissive environment with the aims of ensuring the Haitian armed forces and police comply with the Carter-Cedras accords, protection of U.S. citizens and interests, designated Haitians, and third country nationals, restoring civil order, assisting in the reorganization of the Haitian armed forces and police, and assisting in the transition to a democratic government with the return of President Aristide. The mission statement of the Multinational Force was as follows:

When directed, combined JTF Haiti, conducts combined military operations in Haiti under the operational control of USACOM to protect and, if required, evacuate U.S. citizens, designated Haitians, and third country nationals; to establish and maintain a stable and secure environment; to facilitate the return and proper functioning of the GOH; to provide logistical support to coalition forces; to professionalize the military component of Haitian public security forces; and on order, to turn over responsibility for ongoing operations to the government of Haiti or designated international organizations.<sup>86</sup>

By October 15, 1994, President Aristide was returned to Haiti.<sup>87</sup>

There were two CMOC operations in Haiti: one was in the J3-CA section of the JTF Headquarters in Port-au-Prince, and the other was in Cap-Haitien as a part of the 2d Brigade, 10th Mountain Division (LI) Headquarters. The CMOC in the JTF Headquarters had little or no contact with NGOs. Instead, a Humanitarian Assistance Coordination Center (HACC) was established as the meeting place for NGOs, and requests for support were then sent to the CMOC cell in the J3.<sup>88</sup> The CMOC in Cap-Haitien was the brigade fire support element converted into a CMOC. Later in the operation, a CA officer was available for duty in this CMOC, but initially the Brigade Fire Support Officer was the S5/OIC.<sup>89</sup> The Cap-Haitien CMOC used a small HACC as well; it was manned by a captain and an NCO.<sup>90</sup>

The functions of the CMOC in Port-au-Prince were as follows:

- Receive and process requests from numerous NGOs operating in the country.
- Maintain and provide linguists to forces of the JTF.
- Collect and process open-source and J2-provided intelligence which was CA/CMO related.

- Maintain a running CMO estimate for the J3-CA officer.
- Receive and analyze unit SITREPS for CMO-related information.
- Monitor the troop list and support to maneuver commanders.
- Allocate CA units within the JTF via FRAGOs changing the task organization.
- Coordinate with each of the J-staff sections regarding contracts, hiring of civilian personnel, and the Gun for Gourdes Program.
- Coordinate for the repair of President Aristide's residence.
- Coordinate for the use of land to develop weapons ranges.<sup>91</sup>

The 2d Brigade (in Cap-Haitien) mission statement included "conduct CMO operations" and the commander's intent included "Enhance efficiency and effectiveness of NGO/PVO/GOH operations." From this direction, and a limitation of 'don't start what you can't sell off' the CMOC coordinated the following projects:

- Mayor's council; committees of justices, ministers, and organizations.
- Establishing trust and climate of reconciliation.
- Electricity, water, and sanitation.
- Air Traffic Control and the re-opening of the airport for commercial travel.
- Humanitarian assistance/mail flights.
- Fresh water production.
- Port operations.<sup>92</sup>

While Haiti was a poor nation before large scale U.S. intervention in 1994, and will probably remain one of the poorest countries in the western hemisphere for some time, the CMO activity was directed toward convincing the Haitian people that the U.S. (and later the UN) were there to help. All of the assistance provided was an attempt to demonstrate the progress which is possible under a democratic government in contrast with the oppressive rule of the Cedras regime.

The first substantial CALL publication on Haiti indicates the HACC was developed based on the fact that military planners knew that there were some NGOs who were reluctant to work with the U.S. military. The discussion then goes on to generalize that "Based on previous experience with many of these organizations and the understanding that they are uncomfortable being around the military environment of a tactical operations center, a Humanitarian Assistance

Coordination Center was established. By physically locating this center away from military operations centers, but keeping it under the control of the CMOC, coordination with these organizations was facilitated.”<sup>93</sup> According to Colonel Powers, who was the chief of operations in the CMOC and Commander, 96th CA Battalion at the time, the main reason for the HACC was to ensure the NGOs did not have to come into the JOC because the operations center was a secure area.<sup>94</sup> LTC Herrington, who also participated in the CMOC in Haiti as an assistant operations officer and later director, explained in an interview that the NGOs were confused by the term HACC; many of them had experience in working through the CMOC in previous operations and therefore sought to make coordination there again.<sup>95</sup> The third volume of the CALL series on Haiti states “Remotely locating the HACC prevents NGOs and PVOs from inundating the headquarters. Despite repeated direction to contact only the HACC, many organizations called directly into the CMOC with requests.”<sup>96</sup> The Army seems to have taken a step backwards on this point. The CMOC operations in Rwanda were established using FM 100-23-1 as a guide. FM 100-23-1 was written based on the lessons learned from Somalia. The term CMOC had gained some level of familiarity with the NGOs and then the JTF in Haiti used a different term for where the NGOs should go to seek military assistance. To make matters more confusing, Joint Pub 3-08 defines HACC as a CINC level organization and instructs us to use CMOC as the JTF and lower level center for NGOs to make contact with the military. The other doctrinal manuals reviewed stick to CMOC.

The manning for the CMOC and HACC at Port-au-Prince was as follows: CMOC, twenty three CA officers and NCOs (2 COLs, 4 LTCs, 6 MAJs, 1 SGM, 2 MSGs, 4 SSGs, 4 SGTs), the HACC was manned with six CA officers and NCOs (1 COL, 1 LTC, 1 MAJ, 1 CPT, 1 SFC, 1 SGT). LTC Gary Herrington who worked in the JTF CMOC indicated that the mix of officers was too rank heavy and that more NCOs would have been better. As was the case in Operation Support Hope, there was a mix of AC and RC CA personnel.<sup>97</sup> The CMOC effort in Cap Haitien

was fourteen soldiers strong (1 LTC, 1 MAJ, 3 CPTs, 1 SFC, 4 SSGs, 4 SGTs). Since the CMOC in Cap-Haitien drew on the Brigade FSE and artillery personnel, these soldiers were artillery related MOSs. The Lieutenant Colonel was a Reserve Component Civil Affairs officer however.<sup>98</sup>

The location of the CMOC was in the Joint Operations Center of the JTF. This location was adjacent to TF Mountain HQ and was approximately three miles from the 1st Brigade, 10th Mtn Div (LI) headquarters. The JSOTF Headquarters and the Joint Logistics Support Command Headquarters were in buildings across the street from the JOC. COL Powers indicated that coordination in this layout of headquarters was very convenient. Additionally, COL Powers indicated that the CMOC enjoyed an outstanding relationship with the rest of the JTF staff and the 10th Mountain Division owing to the efforts of the 10th Mtn Div (LI) G5 MAJ Robin Freeman.<sup>99</sup>

The HACC was located initially in the USAID center in Port-au-Prince which made communication between the CMOC and the HACC essential. Commercial phone communications between the CMOC, HACC, NGOs, and other organizations were unreliable. Eventually, all parties involved in CMO came to rely on handheld radios which have become the standard in communications with the NGOs.<sup>100</sup>

The availability of vehicles, and force protection measures dictating the sizes of convoys, were a hindrance to coordination.<sup>101</sup> Ideally such policies are determined prior to deployment and their impact of other operations are considered. By now, CA planners should be the first to make the point in planning sessions that if these force protection rules are going to be instituted, there will be a degradation to CA effectiveness unless more soldiers and vehicles are going to be allocated to CMO activities.

Officers interviewed said that FM 41-10 and Joint Pub 3-57 were the doctrinal publications they consulted.<sup>102</sup> Both acknowledged the shortcoming of FM 41-10 and were quick to point out

that it was being rewritten. Numerous entries in the CALL series on Haiti identify shortcomings in FM 41-10 and offer suggestions for its improvement. There was no mention of the draft FM 100-XX, HA Multiservice Procedures for Humanitarian Assistance Operations.

In summary, Operation Uphold Democracy continued to demonstrate the need for the military to harness the capabilities of non-military organizations via the CMOC (or HACC). Unfortunately, planners failed to familiar doctrinal terms which caused confusion. The aspects of communications and vehicle support once again surfaced as seen in previous operations and as found in the CALL publications, the stereotype given to NGOs wishing to remain aloof from the military is still reinforced. Compared to Operation Support Hope, there is a great deal more information available (especially from CALL) on Operation Uphold Democracy. Hopefully the lessons captured from Haiti will be leavened with those from previous operations to develop a more comprehensive and coherent doctrine for the CMOC. While progress continues to be made in working more harmoniously with NGOs, there is still much room for improvement.

The three operations discussed above (Somalia, Rwanda, and Haiti) point out the importance of integrating the capabilities of NGOs in MOOTW and the challenges associated with achieving unity of effort with non-military organizations in theater. Clearly, the efforts to improve doctrine have helped in this endeavor, but there needs to be more detail and consistency. The need for increased emphasis in the training of CA officers and senior leaders in dealing effectively with NGOs is also apparent. The planning of CMO takes place in broad terms, but the detailed planning required to properly integrate CA assets seems lacking or is ignored by senior leaders who do not appreciate the importance of establishing a rapport with NGOs which includes early deployment of CA assessment teams, and establishing functional CMOCs upon arrival of the main body. Senior leaders have seemed to recognize that they “need a CMOC,” which is perhaps the most important achievement thus far.

## THREADS OF CONTINUITY

In order to arrive at a model CMOC, we must first recognize the common elements of doctrine and experience. While some of these similarities are apparent from the review of doctrine and the three operations, a review will help in understanding the basis for the model which follows. The similar aspects for discussion fall into five categories: functions, manning, location, communications, and flexibility.

The core functions of the CMOC are: (1) coordination with NGOs and other nonmilitary organizations impacting on the mission, (2) receiving, processing, and coordinating requests from these organizations for support (especially in terms of security and transport), (3) gathering information/intelligence, disseminating information from the military to NGOs, and (4) attempting to focus the efforts of the NGOs in a manner which supports the objectives of the commander.

The CMOC has always been manned primarily by CA personnel. Civil Affairs officers, NCOs, and soldiers run the CMOC as a doctrinal task. NGOs seem to communicate better with CA personnel.<sup>103</sup> The CMOC works best when it is headed by an officer who has sufficient rank, experience, and credibility to communicate effectively with the chief of staff or commander of the headquarters the CMOC serves. Based on the situation, there must be sufficient personnel to address the needs of the NGOs (commensurate with the number present in the AOR) and conduct 24 hour operations when required. Careful thought must be given to creating the right mix of active duty CA "generalists" and reserve component "specialists." This task may be constrained by the ability to get RC personnel activated for active duty and when (and how long) they will be available for employment. There may also be a need for special skills or experience to make the CMOC more effective (international and contract law, transportation, etc.) Finally, not all personnel need to be CA qualified; the important point is to get the most effective person for the tasks which must be carried out.

The next aspect of commonality is that of location of the CMOC. In terms of an ideal

situation, the CMOC would be located adjacent to the military headquarters (the main CP) *and* at such a location that is most convenient (and secure) for NGOs to attend daily CMOC meetings. This close proximity to the headquarters and the NGOs facilitates coordination and increases the likelihood that NGOs will visit the CMOC and attend daily meetings. Short of the ideal, a balance must be struck between facilitating coordination with the headquarters and finding a location that maximizes NGO participation.

Most literature available on CMOC activity makes note of the importance of communications planning for both the military and NGOs. Commercial phone circuits and frequency management must accommodate both military and NGO traffic. The CMOC must be equipped with communications gear to link it with the military headquarters and the NGOs (eg. hand held radios and desktop and mobile phones). This critical command and control aspect of the CMOC was not properly taken into consideration by planners in each of the three recent operations discussed earlier.

Finally, the CMOC must be flexible. The initial composition of personnel, equipment, location of the facility may not be most effective. The conditions of the operation will certainly change, and the number, type, and location of NGOs will probably change also. The CA planner must recognize this fact and periodically assess whether or not the CMOC can be improved during the operation. The periodic assessment should focus both on how well the CMOC is making contact with NGOs as well as its effectiveness as a staff or subordinate element of the military headquarters which it serves.

To summarize this section, the CMOC is found to have similarities in terms of functions, manning, location, communications, and the need for flexibility. These similarities serve to strengthen the notion that a model CMOC can be developed as a starting point for planners faced with the task of determining the requisite personnel, equipment, and procedures for a CMOC. While a model CMOC must be adjusted to the situation in terms of available assets, the mission, the capabilities of NGOs, US, and UN organizations in the AOR, it can help the planner to identify

what the military needs to do in order to achieve unity of effort for a given mission.

#### A MODEL CMOC

Developing a model CMOC must draw from both doctrine and recent experience to ensure it is understood and relevant. The model should begin with only the essentials required for a CMOC and then identify capabilities which can make it more effective if more staff officers, CA units, and other resources are available. It cannot be emphasized enough that every situation will require a different CMOC in terms of resources, location, and functions. This section of the monograph attempts to integrate the information presented thus far to provide a concept for quick adaptation to an actual operational requirement or serve as the object for discussion for the improvement of doctrine. The description of the model CMOC will include its external relationship to the staff, functions, internal organization, manning, location, equipment, and other characteristics which may increase the models effectiveness.

The design of any CMOC should begin before its deployment into theater with information from CA assessment teams deployed ahead of the main body. Civil Affairs assessment teams must be among the first to arrive in theater in order to make contact with host government, UN, NGOs, and commercial organizations to ensure the right mix of capabilities has been identified for the operation. Assessment teams can make recommendations as to the initial location of the CMOC, communications means required to tie in with the nonmilitary organizations in theater, and determine more accurately the nature of assistance required by the humanitarian organizations in the AOR and the affected population. Additionally, the CA assessment teams will be among the first to make contact with the UN organizations and NGOs. This first contact and impression may determine how quickly the CMOC is able to harness the efforts of the humanitarian and civil organizations in the AOR.

The term "CMOC" should not change. The preponderance of doctrine and literature written on the subject makes CMOC the most recognized term for both the NGOs and the members of the military. The CMOC is where the NGOs and other nonmilitary organizations go to coordinate for

assistance from the military -- not the HACC. The least productive thing the military can do in terms of the refining doctrine on this subject is to change the name of the CMOC and generate confusion.

The external relationship of the CMOC is crucial to its effectiveness with the commander and staff it is associated with. In keeping with USAJFKSWCS Publication 525-5-3, each coordinating staff should have a cell which is responsible for CMO which needs to be located in the main command post. In corps and divisions, this section is the G5 (the JTF, an ad hoc staff, should designate an officer with similar responsibilities). This staff section is the link between the CMOC and the G3/J3. See diagram 13. Both the director of the CMOC and the G5 should have access to the Chief of Staff as a minimum, and ideally to the ADCs and Commander. Either the G5 or the CMOC director needs to be on the same footing (rank and credibility) as the G3/J3 and the other principle coordinating staff officers. Because of the importance of generating unity of effort in theater, and the importance of establishing and maintaining a productive relationship of the military with IOs, NGOs, and other governmental agencies, the CMOC director should work for the Chief of Staff. If this is not the case, the CMO effort will become subsumed into "operations" and will not get the command emphasis it needs. This is not to say that the J3 is not the central focus of operations -- all activity of the unit must ultimately be approved and directed via orders and FRAGOs from the G3/J3. Requests for support must be sent through the G5/CMO section to the G3/J3 who retains tasking authority of the units assets. The CMOC is not a unit, has no established support structure, and therefore should not be a subordinate to a JTF or division; it should remain essentially at staff element.

The functions the model CMOC should perform are as follows:

- Act as the primary coordinating agency for IOs, NGOs, and USG agencies when DoD is in control of the theater but may support if DOS, UN, or other organizations control or share control of the theater.
- Assist the commander in generating unity of effort among nonmilitary organizations in theater.

# The Model CMOC External Relationships

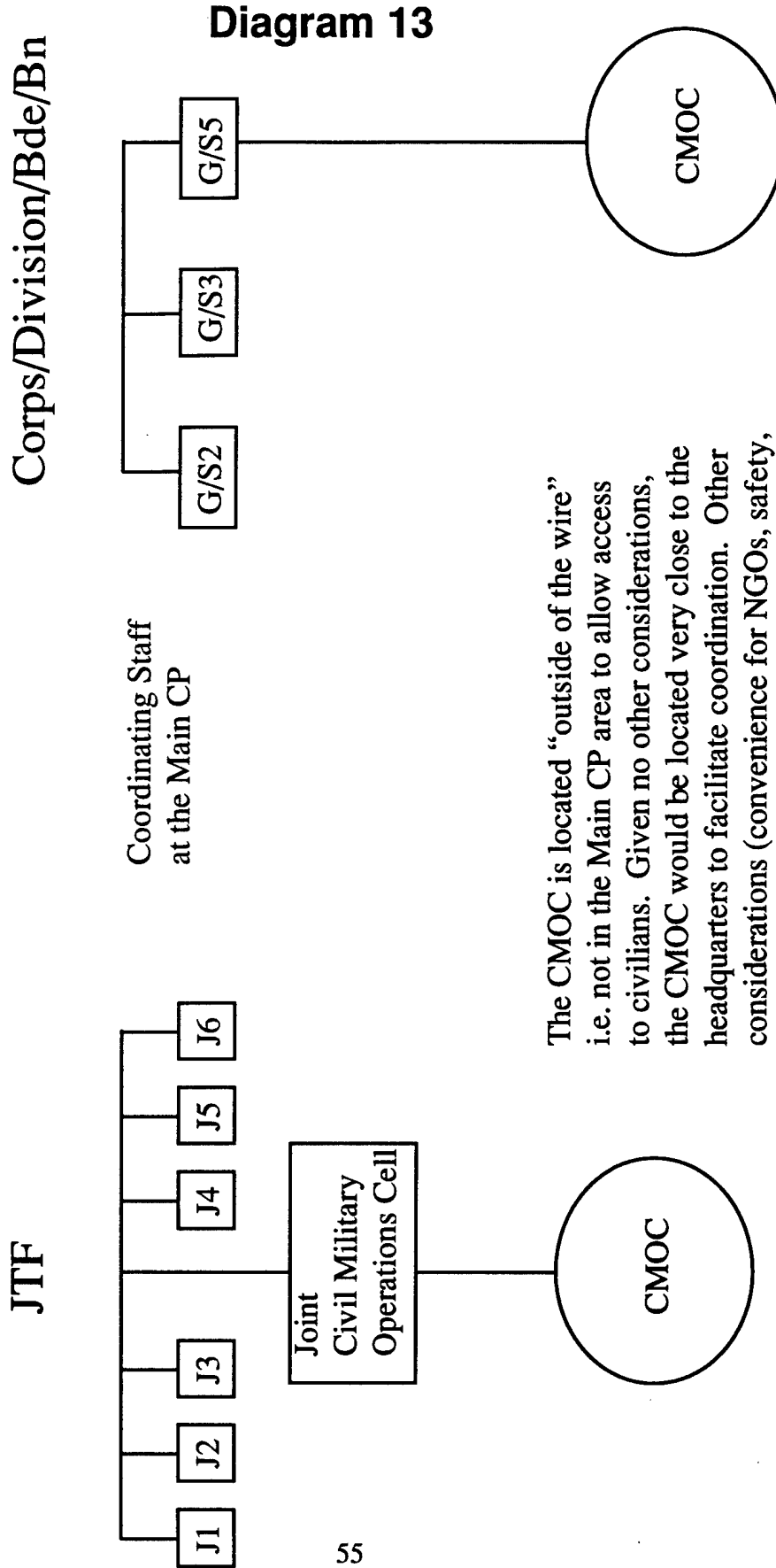

The CMOC is located "outside of the wire" i.e. not in the Main CP area to allow access to civilians. Given no other considerations, the CMOC would be located very close to the headquarters to facilitate coordination. Other considerations (convenience for NGOs, safety, UN/host nation/USG agency influences, proximity to key activities) may necessitate the CMOC be located further from the Main CP.

- Receive, validate, and process UN/NGO/IO requests for military support.
- Followed-up to ensure that requests were completed.
- Convene ad hoc mission planning groups for complex military support requests (e.g. convoy escorts) with UN/NGO/IOs.
  - Validating NGO personnel requests for space available seats on military aircraft.
  - Integrate the military into multinational and military-civil partnership efforts.
  - Coordinate military requests among components and multinational forces if any.
  - Provide a conduit of information from the commander to the NGOs.
  - Explain JTF policies to UN/NGOs/IOs.
  - Collect Information/Intelligence.
  - Provide information to the NGOs on military security operations, location of mines and other hazards.
  - Conduct frequent (daily) meetings with NGOs, and other participants for situation updates and information collection and dissemination.
  - Ensure CMOC efforts work in harmony with PSYOP and Public Affairs themes.
  - Coordinate for media exposure of positive efforts by organizations who participate/contribute to CMOC efforts.
  - Coordinate medical requirements.
  - Maintain 24 hour operations when necessary.
  - Respond to emergency requests for assistance from NGOs by requesting assistance from the Main CP operations center.
  - Conduct CA assessments.
  - Support CA teams as required.
  - Maintain contact/coordination with other CMOCs in theater.
  - Chair port and airfield committee meetings for space and access related issues.
  - Facilitate creation and organization of a food logistics system for food relief efforts if required.
  - To the extent practical, educate NGOs about how the military operates.
  - Assist in the transition of humanitarian activities to nonmilitary organizations as U.S. forces prepare for redeployment.
  - Capture lessons learned and contribute to the body of knowledge available on CMOC operations.

While the CMOC will invariably be called upon to perform other functions, doctrine and past

experience indicate those listed above are the most likely a CMOC can expect to face.

The internal organization is shown in diagram 14 which closely resembles diagrams shown in doctrinal publications. The differences are as follows: The operations section needs to be capable enough to perform information/intelligence collection which is noted as an important aspect of CMOC operations in various publications, but never identified in terms of resources or organization. If the CMO cell on the staff is not sufficiently resourced to do planning, the CMOC must be prepared to take on this responsibility. At a minimum, representation must be provided to all planning efforts of the staff to ensure CMO and CMOC specific issues are taken into consideration. The model CMOC also includes a transportation section. This is added in recognition of the many transportation related functions the CMOC is involved with. Representation of this sort in the CMOC would increase the responsiveness of the military to NGO requests. The section could be a small cell from the J4/G4 or CA personnel with expertise in movements. Other functional sections should be added to the CMOC structure if required.

As with any staff, liaison is important. Liaison officers (LNOs) must be properly integrated into meetings and given the proper attention and information they need to help the organizations they represent. The CMOC should be prepared to receive LNOs and provide for their needs. Additionally, the CMOC may need to dispatch its own LNOs; another consideration for planning prior to the deployment of CA assets.

The personnel required for the model CMOC are listed below:

Colonel /LTC	Director
Lieutenant Colonel, CA	Deputy Director
Major, CA	Operations Officer
Captain, CA	Assistant Operations Officer
3 SSG-SFC, CA	Operations NCOs
Captain, TC	Transportation Section OIC
SFC, TC	Transportation NCO
Master Sergeant, CA	NCOIC
Staff Sergeant or Sergeant First Class	Admin NCO
Sergeant	CA NCO/Assistant Admin NCO
2 Enlisted Soldiers	Admin/CA Specialists
2 Enlisted Soldier	Drivers
LTs/NCOs	LNOs as required

## The Model CMOOC Internal Organization

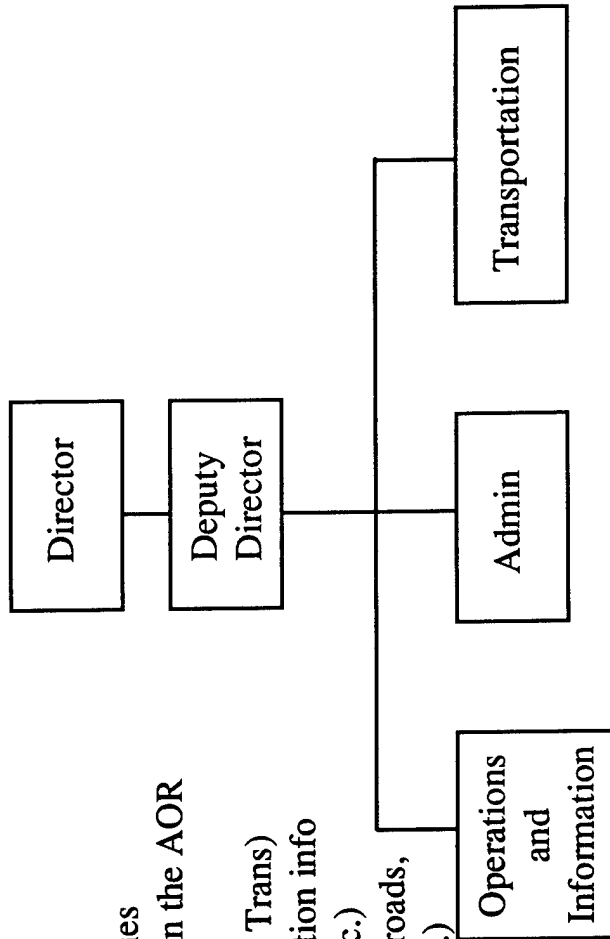

### Posted Information:

- Military Mission
- Cdr's Intent
- Weather forecast
- Ongoing/Future projects
- Location of NGO activities
- List of NGOs operating in the AOR
- Status of Requests
- Status of CSS units (esp. Trans)
- Force (and NGO) protection info (mines, disease hazards, etc.)
- Status of infrastructure (roads, bridges, ports, airfields etc.)

### Major Equipment

- HMMWVs w/radios
- Nontactical vehicles as req.
- Automation equipment
- Map boards, status charts
- Comms (tactical, commercial, handheld FM, fax; compatible with NGOs and main CP)
- Tables, chairs, projection/briefing equipment, tentage, etc.

### Additional Sections (based on METT-T)

- Legal
- Medical

Diagram 14

The director of the CMOC should be someone known and respected in the headquarters staff as was the case in Somalia. The ideal then seems to be a staff officer, equal in rank to the coordinating staff officers who reports to the Chief of Staff or Deputy Commander but sends requests for support through the CMO cell or G5 as a coordinating staff section to the G3/J3 as described earlier in diagram 12. Other additions to the CMOC may include a Judge Advocate General officer who is familiar with international and contract law and logisticians (especially transportation officers) who can quickly determine the feasibility of support requests. The personnel selected to serve in the CMOC would ideally have first-hand experience in dealing with NGOs from a past operation. Training rotations to the JRTC provide some soldiers with experience in dealing with NGOs, but this contact is limited.

The location of the CMOC must be evaluated in terms of facilitating coordination with its military headquarters as well as the NGOs. A convenient, secure location for the NGOs outweighs close proximity to the military headquarters. Location may also be a function of available communications equipment. The CMOC may be best located at the hub of NGO activity (a port, airfield, urban center, refugee camp, etc.). As in previous operations, the degree to which the U.S. military, UN, or host nations decide what organization will lead the humanitarian effort of an operation may dictate a location for the CMOC. In such circumstances, the CMOC must attempt to overcome any disadvantages (distance, coordination with headquarters, communications, support etc.) resulting from a less than optimal location. In the case of multiple CMOCs, it is also important for the commander, and the senior officer responsible for CA/CMO support in theater to visit each CMOC to ensure he appreciates the "ground truth" where each CMOC is located.

The model CMOC should also program frequent visits by representatives from the elements of other staff sections (especially the intelligence and logistics). Such visits serve the following purposes: 1) the other members of the staff gain an appreciation of the tasks the CMOC accomplished in support of the overall mission; 2) other staff sections can gain first-hand

information (especially the G2/J2) from the CMOC personnel and the NGOs; 3) having seen the CMOC operation as an unbiased observer, the visiting staff officer may be able to offer suggestions to the CMOC personnel or the NGOs which could be beneficial to both (the thought being the members of the CMOC may be too close to a problem to see alternatives for its solution); and 4) the visiting staff officer himself gets exposure to the NGOs and can attest to his fellow staff officers that the CMOC people have not “gone native” as Jonathan Dworken suggests happened in Somalia.<sup>104</sup>

The model CMOC must have access to vehicles in order to properly coordinate with military units, host nation organizations and facilities, UN and nongovernmental organizations. If there is going to be constraints on movement (eg. force protection rules) that require a certain number of vehicles or soldiers to travel as a group, then these considerations must be accounted for in the planning stages of the operation. In Somalia and Haiti, CMOC officers felt unduly constrained by force protection rules.

Other equipment needs include computers, printers, fax machines, and the right communications to contact NGO, USG, host government, and UN personnel as well as the headquarters' elements, and units providing the support to humanitarian assistance. Planners must anticipate a greater demand for satellite communications out of the AOR, such as INMARSAT, and also determine if commercial phone lines in theater will support the communications required of the military to coordinate with non-military organizations. Sufficient handheld radios should be available, and the CMOC needs to have a doctrinal military link with its headquarters. Otherwise, common meeting room equipment including tables, chairs, bulletin boards and projection equipment sufficient for the anticipated size of meetings is all that is required.

The model CMOC should also be conducting its own information campaign to educate the military about NGOs and vice versa. There should be a complete set of doctrinal publications (all those mentioned in the doctrine section as well as keystone joint and service manuals) and

publications that give information on NGOs, available for use by CMOC soldiers as well as browsing by interested NGO representatives or military liaisons. The unit mission, commander's intent, and other current operations information should be posted so NGOs gain an appreciation for the scope of the military's effort as well as the limitations of available assets. The model CMOC should have as one of its tasks the training of NGOs about the military. This could be accomplished in any number of ways from short classes, to pamphlets available in the CMOC, to introductory briefings given in the first weeks of the operation. As with any good maneuver unit, training continues during employment.

The CMOC director and the CMO staff element at the headquarters should also be coordinating closely with the public affairs officer and the media. The CMOC is an excellent place for the military to give credit to the NGOs efforts in a public forum. As discussed early in the monograph, positive exposure to the media is a component to the NGOs' success in terms of legitimacy and funding.

The CMOC model presented has been a synthesis of the available doctrine and three recent operations employing a CMOC. While it is recognized that every operation will have its own characteristics and requirements, a detailed starting point for planners is always more helpful than broad guidance, or no conceptual framework at all. This model established a baseline requirement for a CMOC and addresses some additional capabilities and considerations which would make it more effective given the resources are made available. The intangible aspects of leadership and interpersonal communication, regardless of how well a CMOC is established, will "make or break" its overall effectiveness. Those officers and NCOs working in the CMOC must effectively deal with both the civilians who come to the CMOC for assistance and the military staff at the headquarters. Some soldiers do this better than others thus it is important to select the right individuals to work in the CMOC. A good team of soldiers in the CMOC, a clear idea of what the military commander is trying to achieve, and a sound understanding of how the CMOC can generate unity of effort is the recipe for success.

## SUMMARY

This monograph began by establishing the importance of working together with NGOs and other non-military organizations in MOOTW. The mechanism for fostering that teamwork is the CMOC. The paper defined "CMOC" in doctrinal terms along with "NGO" and "PVO" and then examined the culture of the NGOs. This discussion of NGOs revealed a diverse community with varying view points on the principles of humanitarian action, and the degree to which NGOs should cooperate among themselves and the military. The next phase of the paper focused on the doctrine available on the subject of the CMOC and NGOs. While there is useful information in doctrinal publications, it is disjointed and lacks consistency in and between service and joint manuals. The monograph then looked briefly at three recent operations employing CMOCs: Operation Restore Hope in Somalia, Operation Support Hope in Rwanda, and Operation Uphold Democracy in Haiti. Each operations' CMOC had unique characteristics, but many similarities as well. Having looked at the three recent examples of CMOCs in action, the paper drew out common characteristics of these operations, and, with available doctrinal, developed a model CMOC. The model CMOC in this monograph attempts to serve the military in providing a conceptual point of departure for planners and operators faced with the task of fielding a CMOC in our next MOOTW, and providing a basis for discussion in writing future doctrinal manuals.

## CONCLUSION

The monograph has demonstrated that the idea of CMOC operations is now firmly rooted as a crucial aspect of MOOTW. The important aspects of CMOC operations fall into three categories: (1) the NGO environment, (2) information available on establishing and operating a CMOC, (3) steps to educate leaders and NGOs to facilitate unity of effort.

The environment in which the military operates will invariably include NGOs and other non-military organizations. NGOs have much to offer the U.S. military in terms of resources and information in theater. They can also be either a positive or negative influence on the indigenous population as they perceive the military. In light of their ever increasing numbers and global

coverage, the military needs to treat NGOs as members of a unified team with a common goal. To ignore or hinder NGO operations (intentionally or otherwise) is only counterproductive for the military. The more military leaders know about the culture of NGOs, their motivation, ideals, and peculiarities, the greater the unity of effort in theater, and perhaps the faster objectives will be achieved.

Essential to understanding NGOs, and reaching them via the CMOC, is a coherent body of joint and service doctrine and related publications made available to not only CA units, but to officers in the field and in service schools. Mature doctrine will result in better integrated staffs and CMOCs that are properly manned and resourced. Doctrine and related information on the CMOC (and the military in general) should also be made available to NGOs in an attempt to increase their understanding of how the military operates and what the military can provide that may be of value to their operations.

While recent experience indicates senior leaders appreciate the importance of the CMOC in MOOTW, evidence shows a lack of detail in planning, deployment and execution of CMOC operations. This weakness may be indicative of a need to increase training and awareness of the requirements for a successful CMOC. Education on this subject should be introduced/increased in service schools such as the U.S. Army Command and General Staff College, the Armed Forces Staff College, and other schools where the synchronization of battlefield operating systems and staff procedures are taught. Any increase in the knowledge associated with the CMOC, humanitarian relief operations, and non-military organizations among NGOs and military leaders is bound result in an increase of unity of effort in theater.

Today's military faces scarce resources in terms of manpower, training dollars, and funds for increasingly frequent deployments for MOOTW. The CMOC, by harnessing the capabilities of humanitarian organizations, is a significant factor in increasing the net capabilities of the United States, the UN, and the host nation government of the affected population. For this reason, the military must continue to refine the doctrine associated with CMOC operations, maintain a high

level of command emphasis on unity of effort in MOOTW, and greatly increase the training of senior leaders and CA units in dealing with NGOs, UN organizations, and other U.S. agencies.

## RECOMMENDATIONS

Based on the research required to write this monograph, recommendations are offered for improving the planning, preparation, and execution of CMOC operations. The focus of these recommendations is for CA units, senior leaders, and staff officers who must understand and take advantage of the contribution NGOs make (via the CMOC) to the overall mission of a force conducting MOOTW.

### *Planning:*

- Staffs at division level and higher should understand what the CMOC is, how it contributes to the mission, and where to obtain additional information concerning its establishment and integration into the staff as a whole.
- Planning must be based on reconnaissance in terms of CA assessment teams learning the nature of the AOR in terms of which NGOs are operating in theater, communications, possible location of the CMOC, and the extent of the humanitarian relief effort.
- Thought must be given to the relationship the CMOC will have to the headquarters staff, commander, and subordinate units. If the CMOC is going to act as an arm of the J3 staff, the CA personnel need to be integrated as part of the J3 in addition to running the CMOC. If the CMOC is going to work for the G5 of a division or corps, then this section must be integrated in some way with the G3/J3 to ensure taskings and FRAGOs are properly issued.
- Thought must be given to a tailored package of both AC and RC CA personnel for initial deployment. Some of the specialists in the RC CA units may be required early in the air flow.
- Senior officer and planners must use doctrinal terms. Words have meaning and leaders lose credibility among subordinates and the NGOs when the CMOC changes names from one operation to the next. This kind of confusion is unnecessary and easy to avoid.

***Preparation:***

- Doctrine pertinent to the CMOC and NGOs needs development. Detailed TTPs, which are not available on the subject of the CMOC, would generate thought, and provide a start point for the uninitiated. The often heard comment that the CMOC will be different in every operation or that it is too METT-T dependent should not be an excuse for vague doctrinal manuals. There is an apparent lack of unity of effort among joint and army doctrine writers, and doctrine writers responsible for one manual to the next. Officers should document their experiences and pass on their lessons to those who follow. Joint Universal Lessons Learned System (JULLS), Special Operations Debriefing and Reporting System (SODARS), and CALL are all good mechanisms for capturing operational experience, but analyzing and developing these lessons into doctrine and TTPs is an important step in providing the Army with a lasting, coherent method for conducting operations.

- Officers must be educated as to the purpose and importance of the CMOC and the culture of NGOs. Ignorance results in late or nonexistent planning for civil affairs, improper terminology, and worst of all disenchanted NGOs and a loss of unity of effort.

- Training with NGOs, such as that which took place at JRTC, must continue. The lessons (especially those learned by the NGOs and passed to the military) are invaluable. Both the 96th CA Bn and RC CA units should continue training with NGOs and UN humanitarian relief organizations.

- Division G5s should take the lead in encouraging staff training by including a CMOC in exercises and making sure all members (especially the G3 and G2) of the coordinating staff integrate the CMOC.

- Civil Affairs officers must develop detailed files on the NGOs they are likely to come in contact with. These files (much like military intelligence order of battle files, and field artillery target sheets) should be kept up-to-date and reviewed prior to deployment. NGOs will probably be more receptive to someone who has taken the time to understand their organization.

***Execution:***

- The commander and principle staff officers should make frequent and regular visits to the CMOC.
- The civil affairs officers and the CMOC in general must become better integrated into the staff effort. CMOC officers should be able to recite the commander's PIRs.
- Those working in the CMOC should in turn visit the various coordinating staff sections as well.

## ENDNOTES

1. Colonel Hayward S. Florer, Director, Doctrine and Training Development, U.S. Army John F. Kennedy Special Warfare Center and School (USAJFKSWCS), Briefing to School of Advanced Military Studies, Fort Leavenworth, KS, 2 February 1996. Colonel Florer was Commander, 1st Battalion, 10th Special Forces Group (A) during Operation Provide Comfort. See also Operation Provide Comfort Lessons Learned Observations, Department of Evaluations and Standardization, USAJFKSWCS, Fort Bragg, North Carolina. Some Civil Affairs officers argue that the term CMOC goes back to the 1970s or even earlier to World War II. In any event, the post Cold War era and the proliferation of NGOs doing humanitarian activities in Third World countries make the "modern" CMOC distinctly different from terms or organizations which existed twenty or more years ago.
2. Peter J. Spiro, "New Global Communities: Nongovernmental Organizations in International Decisionmaking Institutions," Parameters Vol XXV No. 1 (Spring 1995) 46.
3. Andrew S. Natsios, "The International Humanitarian Response System," Parameters Vol XXV No. 1 (Spring 1995) 72.
4. Joint Publication 3-0, Doctrine for Joint Operations, Joint Electronic Library Compact Disc (Washington, D.C.: Joint Chiefs of Staff, 1 Feb 1995) xv. Joint Pub 3-07, Joint Doctrine for Military Operations Other Than War (Washington, D.C.: Joint Chiefs of Staff, 16 June 1995) II-3. Field Manual 100-5, Operations (Washington, D.C.: U.S. Government Printing Office, June 1993) 13-4. Field Manual 7-98, Operations In A Low-Intensity Conflict (Washington, D.C.: U.S. Government Printing Office, 19 Oct 1992) 1-2. Field Manual 100-20, Military Operations In Low Intensity Conflict (Washington, D.C.: U.S. Government Printing Office, 5 Dec 1990) 1-5. The concept of unity of effort is that all participants work towards a common goal. This concept is different from the traditional principle of war "unity of command." Unity of command implies that all forces are subordinate to one military commander. In MOOTW many organizations (NGOs/PVOs for example) are not subject to military command, and therefore commanders seek unity of effort from those actors they cannot command.
5. U.S. Army John F. Kennedy Special Warfare Center and School Publication 525-5-3, Civil-Military Operations Staff Support to Army Corps and Division G5 Sections (Fort Bragg, NC: USAJFKSWCS, July 1995) 10. Joint Publication 3-08, Interagency Coordination During Joint Operations, First Working Draft (Washington, D.C.: Joint Chiefs of Staff, 18 October 1994) offers another definition on page GL-11: "An ad hoc organization, normally established by the joint task force commander, to assist in the coordination of activities of engaged military forces, and other USG agencies, NGOs, PVOs, and IOs. There is no established structure, and its size and composition are situation dependent. Also called CMOC."
6. Joint Publication 3-07, GL-4-GL-5.
7. Natsios, 75.
8. Ibid., 73. Marion Harroff-Tavel, "Action Taken by the International Committee of the Red Cross in Situations of Internal Violence," International Review of the Red Cross, (September 1993) 199.
9. Department of the Army Field Manual 100-23, Peace Operations (Washington, D.C.: U.S. Government Printing Office, December 1994) 83.
10. Ibid., 78-82.
11. Air Land Sea Application Center, Field Manual 100-23-1, HA Multiservice Procedures for Humanitarian Assistance Operations (Langley Air Force Base, VA, Air Land Sea Application Center, October 1994) 1-1 - 1-2.

12. Joint Warfighting Center, JTF Commander's Handbook for Peace Operations (Washington D.C: Joint Chiefs of Staff, 28 February 1995) 22. Joint Publication 3-08, I-21 - I-22.
13. Spiro, 46.
14. Natsios, 69. D. M. Last and Don Vought, "Interagency Cooperation In Peace Operations: A Conference Report" (Fort Leavenworth, KS: United States Command and General Staff College, October 1994) 9. Last's figures are slightly different: "American NGOs assist 250 million people a year, they spend more than \$9 billion a year, including more than \$600 million in U.S. government funds."
15. Jonathan T. Dworken, Military Relations with Humanitarian Relief Organizations: Observations From Restore Hope (Alexandria, VA: Center for Naval Analysis, October 1993) 37-40.
16. Balbeer K. Sihra, "Relief Agencies and the U.S. Military: Partners in Humanitarian Operations," Marine Corps Gazette (March 1994) 43.
17. Thomas K. Adams, "Cooperation With Non-Military Agencies and Organizations", Briefing Slides (Fort Leavenworth, KS: U.S. Army Command and General Staff College, September 1995) slide number 12.
18. Natsios, 70.
19. Thierry Germond, "Co-operation Between the ICRC and UNPROFOR in the Former Yugoslavia," Address by the Delegate General of the ICRC for Western and Central Europe, and the Balkans at the Occasion of the North Atlantic Assembly, Rose-Roth Seminar, on 'The Theory and Practice of Peacekeeping' (London: ICRC, 22 February 1994) 3.
20. Larry Minear and Thomas G. Weiss, "Humanitarian Politics," Headline Series No. 304 (Fall 1995) 16.
21. Natsios, 74.
22. Last, 12.
23. Natsios, 69-72.
24. Ibid., 72.
25. Ibid., 79.
26. Charles B. Deull and Laurel A. Dutcher, Working Together: NGO Cooperation in Seven African Countries (New York: InterAction/Merrill, 1987).
27. Adams, slides 15 and 16.
28. Catholic Relief Services, CRS Guidelines on Humanitarian Assistance in Conflict Situations, Harpers Ferry Workshop, April 1992.
29. Jonathan T. Dworken, "Restore Hope: Coordinating Relief Operations," Joint Forces Quarterly (Summer, 1995), 18.

30. Lauren Landis-Guzman, et. al. NGO After-Action Review of JRTC Exercise in Peace Enforcement (Fort Polk, LA: InterAction, November 1993).
31. Last, B-1 - B-7.
32. Joint Pub 3-07, IV-3.
33. Ibid., IV-5.
34. Ibid., IV-7.
35. Ibid., IV-9, IV-11.
36. Joint Publication 3-08, Interagency Coordination During Joint Operations. Working First Draft (Fort Monroe, VA: Joint Chiefs of Staff, October 1994) III-21.
37. Ibid., I-18.
38. Ibid., IV-7.
39. Ibid., IV-17 - IV-20.
40. Ibid., IV-20.
41. Ibid., IV-22 - IV-26.
42. Joint Publication 3-57, Doctrine for Joint Civil Affairs (Washington, D.C.: Joint Chiefs of Staff, 21 June 1995) IV-3.
43. Joint Task Force Commander's Handbook for Peace Operations. EX-3.
44. Ibid., EX-4 - EX-9.
45. Ibid., 22-23.
46. Ibid., 20. This point is emphasized again on page 30.
47. Ibid., 16. This point is emphasized again on page 56.
48. Ibid., 42-44.
49. FM 100-23, 43.
50. Ibid., 14-15; 16; 27-29; 76.
51. FM 100-23-1, 1-2 - 1-2; 3-6; 3-10.
52. Ibid., 3-10; 4-8; 4-11; 4-12.

53. Ibid., 4-15 - 4-18.
54. Field Manual 41-10, Civil Affairs Operations (Washington, D.C.: U.S. Government Printing Office, 11 Jan 1993) 10-18 - 10-20; 14-4 - 14-5; D-3 - D-4.
55. USAJFKSWCS, Publication 525-3-1, Civil Affairs: A Function of Command, (Fort Bragg, NC: USAJFKSWCS, 6 Jan 1995) 3, 6-8.
56. USAJFKSWCS, Publication 525-5-3, 3-4; 8.
57. Ibid., 8-11
58. Ibid., 11-12.
59. Kenneth Allard, Somalia Operations: Lessons Learned (Fort McNair, Washington, D.C.: National Defense University Press, 1995) 14-15.
60. Dworken, 17. Allard 70.
61. Dworken, 18-19. This work uses the term HRO. It appears to mean NGOs plus any other organization with the aim of doing humanitarian work.; MAJ Jim Nelson, Author interview, Fort Leavenworth, KS, 29 Jan 96. MAJ Nelson was a participant in CMOC operations in Somalia
62. MAJ Jim Nelson, Author interview. Allard, 69-70, 109-111. Sources vary on the number of NGOs that participated in this operation. Several were there as early as the late 1970s (David J. Zvijac and Katherine A.W. McGrady, Operation Restore Hope Summary Report) while others indicate the number was greater than 50. Dworken's JFQ article (page 16) indicates that the number doubled between December 1992 and March 1993.
63. Dworken, 17-18.
64. MAJ Jim Nelson, Author interview.
65. Ibid.
66. Ibid.
67. Center for Army Lessons Learned, Operation Restore Hope Lessons Learned Report, 3 December 1992 - 4 May 1993, Operations Other Than War (Fort Leavenworth, KS: Center for Army Lessons Learned, November 1993), VI-14 - VI-15.
68. MAJ Jim Nelson, Author Interview.
69. COL James F. Powers, Author interview, 12 March 96. Colonel Powers was the commander of 96th CA Battalion.
70. MAJ Jim Nelson, Author Interview.
71. Dworken, 42. MAJ Jim Nelson, Author Interview.

72. Headquarters, United States European Command, JTF Support Hope After Action Review, Briefing slides, 1994.
73. Ibid.
74. COL Karl Farris, Author interview, 27 Feb 96. Colonel Farris, a senior officer in the U.S. Army Peacekeeping Institute, was among the officers making initial assessments in Rwanda.
75. Ibid.
76. MAJ Kent Bradley, Author Interview, 3 Jan 96. MAJ Bradley was assigned to the 96th CA Bn and was a member of the CMOC in Entebbe. In the final stages of the operation, MAJ Bradley was OIC of both CMOCs (Entebbe and Kigali).
77. LTC Fred Jones, Author interview, 26 Feb 96. LTC Jones was the OIC of the CMOC in Kigali.
78. Author interviews: MAJ Bradley for CMOC Entebbe figures, LTC Jones for CMOC Kigali figures, and COL Farris for CMOC Goma figures.
79. LTC Jones, Author interview.
80. COL Farris, Author interview.
81. Author interviews: MAJ Bradley, LTC Jones, COL Farris.
82. COL Farris, Author interview. EUCOM JTF Support Hope After Action Review briefing slides. An interesting point of view found in Operation Support Hope AAR material hypothesizes that the effects of the JTF and humanitarian organizations resulted in the support of the Hutus as a government in exile: "There was a wide perception that the U.S. JTF, as a relief provider, was somehow "outside" the political issues that precipitated the flight of refugees. To a large degree the refugee exodus was a political phenomena, a remarkable attempt by the defeated Hutu leadership to take their constituency into exile with them. The international relief effort quickly became a factor in the Rwandan internal political conflict. The consistent refusal of the US military at all levels to recognize this led to a serious misunderstanding of events in and around the Rwanda crisis area making it increasingly difficult to create realistic and effective plans. By supporting the refugees in the Zaire camps the relief effort made it possible for the exiled Hutu leaders to support hundreds of thousands of Hutus as a government and people in exile. However, both the relief effort in the camps and the effort to return Hutu refugees was seen as a primarily administrative-logistic exercise. To the Rwandan factions it was a crucial political issue since efforts to return the refugees were seen as support to the now Tutsi government. Likewise, reconstruction and rehabilitation activities were portrayed by Hutu leaders as efforts to underwrite the power of the Tutsi government. At one point the JTF was solicited to assist the refugees with transportation and even help persuade them to return. This would have placed their lives in jeopardy and made the US responsible. As events developed, even those remaining in the Goma camps who expressed plans to return were threatened, attacked and sometimes killed by Hutu activists."
83. Author interviews: LTC Jones, MAJ Bradley.
84. Author interviews: Col Farris, LTC Jones, MAJ Bradley.
85. Stephen M. Epstein, "JTF Haiti: A United Nations Foreign Internal Defense Mission." Special Warfare Vol 7 #3. (July 1994), 3.

86. 10th Mountain Division (LI), Briefing Slides, undated.
87. Center for Army Lessons Learned (CALL), Operation Uphold Democracy, Initial Impressions, Haiti D-20 to D+40 (Fort Leavenworth, Kansas: U.S. Army Training and Doctrine Command, December, 1994) i.
88. LTC Gary Herrington, Author interview, 24 Jan 96. LTC Herrington was a member of the CMOC in Operation Uphold Democracy.
89. 2d Brigade Combat Team, 10th Mtn Div (LI), Briefing Slides, undated.
90. James R. Kingham, Memorandum for 25 ID ADVON, Subject Civil Affairs Meetings, with enclosures, Cap-Haitien, Haiti, 2d Commando Brigade, 10th Mountain Division (LI), 28 November 1994.
91. COL James Powers, Author interview.
92. 2d Brigade Combat Team, 10th Mtn Div (LI), Briefing Slides, undated.
93. CALL, 199.
94. COL James Powers, Author interview.
95. LTC Gary Herrington, Author interview. LTC Herrington added that training videos (with an introduction by the CSA, Gen Sullivan) were created specifically for the NGOs that instructed them to go to the "CMOC" for assistance.
96. Center for Army Lessons Learned (CALL), Initial Impressions Volume III, Haiti: The U.S. Army and United Nations Peacekeeping, Fort Leavenworth, KS: Center for Army Lessons Learned, July 1995. 161.
97. LTC Gary Herrington, Author interview. CALL Operation Uphold Democracy Initial Impressions Haiti, D-20 - D+40, December 1994, vi.
98. Kingham, enclosure to memorandum. CALL, Operation Uphold Democracy Initial Impressions D-20 - D+40, December 1994, 72-73.
99. COL James Powers, Author interview.
100. LTC Gary Herrington, Author interview. CALL Volume III, 203.
101. MAJ Cummings, After Action Review Comments, 2d Bde CMOC, undated.
102. Author interviews: COL Powers and LTC Herrington.
103. Natsios, 79. "both PVO and UN managers have repeatedly commented how ell they could work with US forces if they could deal with civil affairs officers instead of combat commanders." This notion is also brought out in the article by Stephen M. Epstein, et. al. "JTF Haiti: A United Nations Foreign Internal Defense Mission" Special Warfare (July, 1994).
104. Dworken, 46.

## Annex A

The Humanitarianism and War Project of the Thomas J. Watson, Jr., Institute for International Studies at Brown University, developed a set of eight principles that figure prominently in deliberations by practitioners of humanitarian assistance. Commanders should be aware of the possibility of specific dilemmas and tensions as they conduct peace operations in support of HA.

### Principles of Humanitarian Action in Armed Conflict

1. **Relieving Life-Threatening Suffering:** Humanitarian action should be directed toward the relief of immediate, life-threatening suffering.
2. **Proportionality to Need:** Humanitarian action should correspond to the degree of suffering, wherever it occurs. It should affirm the view that life is as precious in one part of the globe as another.
3. **Nonpartisanship:** Humanitarian action responds to human suffering because people are in need, not to advance political, sectarian, or other agendas. It should not take sides in conflict.
4. **Independence:** In order to fulfill their mission, humanitarian organizations should be free of interference from home or host political authorities. Humanitarian space is essential for effective action.
5. **Accountability:** Humanitarian organizations should report fully on their activities to sponsors and beneficiaries. Humanitarianism should be transparent.
6. **Appropriateness:** Humanitarian action should be tailored to local circumstances and aim to enhance, not supplant, locally available resources.
7. **Contextualization:** Effective humanitarian action should encompass a comprehensive view of overall needs and of the impact of interventions. Encouraging respect for human rights and addressing the underlying causes of conflicts are essential elements.
8. **Subsidiary of Sovereignty:** Where humanitarianism and sovereignty clash, sovereignty should defer to the relief of life-threatening suffering.

Quoted [in FM 100-23] by permission of Larry Minear and Thomas G. Weiss, co-directors, Humanitarian and War Project, from *Humanitarian Actions in Times of War*. Other widely recognized documents have elaborated humanitarian principles. See, for example, "The Mohonk Criteria for Humanitarian Assistance in Complex Emergencies," produced by the Task Force on Ethical and Legal Issues in Humanitarian Assistance, convened by the Program on Humanitarian Assistance World Conference on Religion and Peace, February 1994.

Source: Department of the Army Field Manual 100-23, Peace Operations (Washington, D.C: U.S. Government Printing Office, 30 Dec 1994) page 28.

# NGO Operations

## Equipment/Material Donors:

Gerber, AmWay, Avon, UpJohn hospitals, physicians & others

## Funding:

foundation grants, hospital guilds, Rotary, corporations, individuals

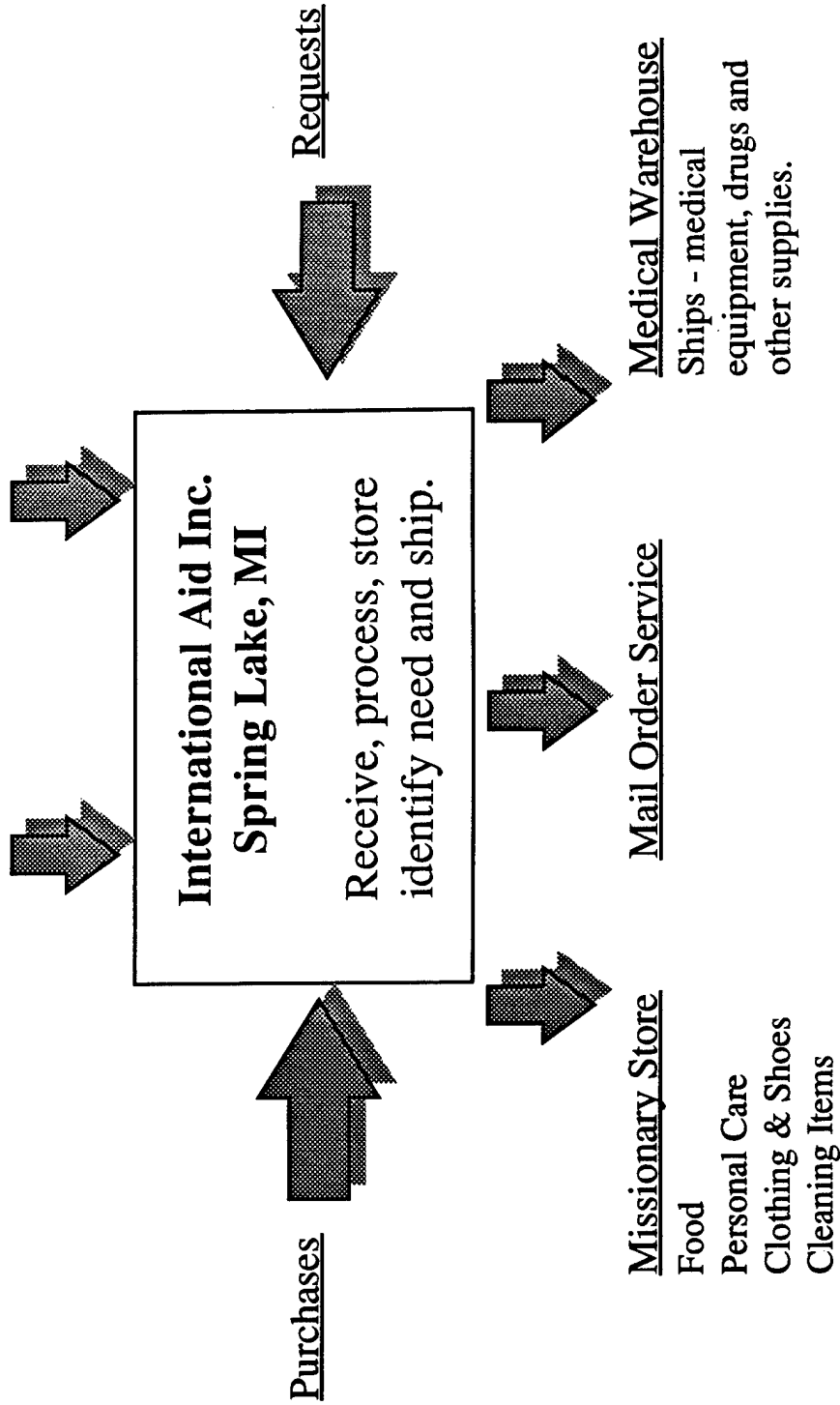

Source: Adams, Thomas K., Cooperation with Non-Military Agencies and Organizations, Briefing Slides, U.S. Army Command and General Staff College, Sep 95.

## Glossary

AC Active Component (Active Duty Military)  
ADC Assistant Division Commander  
AFSC American Friends Service Committee  
AF Amicares Foundation  
AIFC American Friends of Action Internationale Contre La Faim  
AI Amnesty International  
AOR Area of Operations  
BWA Baptist World Alliance  
CA Civil Affairs  
CALL Center for Army Lessons Learned  
CARE Cooperative for American Relief Everywhere  
CAS Children's Aid Society  
CD-ROM Compact Disk-Read Only Memory  
CIDA Canadian International Development Agency  
CINC Commander in Chief  
CJTF Commander Joint Task Force (also Combined JTF, or Coalition JTF)  
CM Civil Military  
CMO Civil Military Operations  
CMOC Civil Military Operations Center  
COMJTF Commander Joint Task Force  
CONUS Continental United States  
CP Command Post  
CRS Catholic Relief Services  
CSS Combat Service Support  
DART Disaster Assistance Response Team  
DoD Department of Defense  
DOS Department of State  
EC European Community  
ECHO European Community Humanitarian Office (modeled after DART)  
ESC Economic and Social Council  
ESG Executive Steering Group  
FAO Food and Agriculture Organization of the United Nations  
FEMA Federal Emergency Management Agency  
FM Field Manual  
FRAGO Fragmentary Order  
FSE Fire Support Element  
GO Government Organization  
GOH Government of Haiti  
HA Humanitarian Assistance  
HACC Humanitarian Assistance Coordination Center  
HMWV High Mobility Wheeled Vehicle  
HN Host Nation  
HOC Humanitarian Operations Center  
HRS Humanitarian Relief Sector  
HRW Human Rights Watch  
IC Irish Concern  
ICRC International Committee of the Red Cross  
ICVA International Council of Volunteer Agencies  
IMC International Medical Corps

## Glossary (cont)

InterAction American Council for Voluntary International Action  
IRC International Rescue Committee  
IO International Organization  
INMARSAT International Maritime Satellite (single channel telephone)  
JCMOTF Joint Civil Military Operations Task Force  
JCS Joint Chiefs of Staff  
JFC Joint Force Commander  
JOC Joint Operations Center  
JRTC Joint Readiness Training Center  
JTF Joint Task Force  
JULLS Joint Universal Lessons Learned System  
LI Light Infantry  
LNO Liaison Officer  
MARFOR Marine Forces  
MCC Mennonite Central Committee  
METT-T Mission, Enemy, Troops, Time, and Terrain  
MSF Medecins Sans Frontieres (Doctors Without Borders)  
MOOTW Military Operations Other Than War  
MOU Memorandum of Understanding  
NCA National Command Authorities  
NCO Noncommissioned Officer  
NGO Nongovernmental Organization  
OFDA Office of Foreign Disaster Assistance  
OIC Officer in Charge  
OSD Office of the Secretary of Defense  
OSOCC On Site Operations and Coordination Center  
PIR Priority Intelligence Requirements  
PSF Pharmacists Sans Frontieres (Pharmacists Without Borders)  
PSYOP Psychological Operations  
PVO Private Voluntary Organization  
RI Refugees International  
RC Reserve Component  
RFA Request for Assistance  
SCF-UK Save the Children Federations-United Kingdom  
SECDEF Secretary of Defense  
SF Special Forces  
SITREP Situation Report  
SOC Special Operations Command  
SODARS Special Operations Debriefing and Reporting System  
SOF Special Operations Forces  
TF Task Force  
TTP Tactics, Techniques, and Procedures  
UN United Nations  
UN-DMT United Nations Disaster Management Team  
UNDHA United Nations Department of Humanitarian Affairs  
UNDP United Nations Development Program  
UNHCR United Nations High Commissioner for Refugees  
UNICEF United Nations Children Fund  
UNITAF United Task Force

## Glossary (cont)

USAOFDA United States of America Office of Foreign Disaster Assistance  
UNOSOM United Nations Operations Somalia  
UNREO United Nations Rwanda Emergency Office  
USACOM United States Atlantic Command  
USAID United States Agency for International Development  
USAJFKSWCS United States Army John F. Kennedy Special Warfare Center and School  
USASOC United States Army Special Operations Command  
USCINCEUR United States Commander in Chief Europe  
USFORSOM United States Forces Somalia  
USG United States Government  
USIA United States Information Agency  
USIS United States Information Service  
USSOCOM United States Special Operations Command  
WFP World Food Program  
WHO World Health Organization  
WVRD World Vision Relief and Development, Inc.

## Bibliography

### Government Publications:

- Center for Army Lessons Learned. Operation Uphold Democracy, Initial Impressions, Haiti D-20 to D+40. Fort Leavenworth, Kansas: U.S. Army Training and Doctrine Command, December, 1994.
- Center for Army Lessons Learned. Operation Uphold Democracy, Initial Impressions, Haiti D-20 to D+150, Volume II, Operations Other Than War. Fort Leavenworth, Kansas: U.S. Army Training and Doctrine Command, April, 1995.
- Center for Army Lessons Learned. Initial Impressions, Volume III, Haiti, The U.S. Army and United Nations Peacekeeping. Fort Leavenworth, Kansas: U.S. Army Training and Doctrine Command, July, 1995.
- Center for Army Lessons Learned. Operation Restore Hope Lessons Learned Report 3 December 1992 - 4 May 1993 Operations Other Than War. Fort Leavenworth, Kansas: U.S. Army Combined Arms Command, November, 1993.
- Center for Army Lessons Learned. Lessons Learned Report, Former Yugoslav Republic of Macedonia, Operation Able Sentry, Operations Other Than War. Fort Leavenworth, Kansas: U.S. Army Training and Doctrine Command, October, 1994.
- Center for Army Lessons Learned. Initial Observations, Migrant Camp Operations Panama/Cuba, Operations Other Than War. Fort Leavenworth, Kansas: U.S. Army Training and Doctrine Command, May, 1995.
- U.S. Army Peacekeeping Institute. Draft Report, Operation Support Hope, Chapter 6, Civil Military Operations Political-Military Considerations, (obtained from CALL Office, Fort Leavenworth, KS) Carlisle Barracks, PA: U.S. Army Peacekeeping Institute, 1995.
- Joint Warfighting Center. Joint Task Force Commander's Handbook for Peace Operations. Fort Monroe, VA: U.S. Government Printing Office, February 1995.
- Joint Chiefs of Staff. Joint Pub 3-07. Joint Doctrine for Military Operations Other Than War. Washington, D.C.: Government Printing Office, June 1995.
- Joint Chiefs of Staff. Joint Pub 3-08. Interagency Coordination During Joint Operations. Working First Draft. Washington, D.C.: Government Printing Office, October 1994.
- Joint Chiefs of Staff. Joint Pub 3-57. Doctrine for Joint Civil Affairs. Washington, D.C.: Government Printing Office, June 1995.
- U.S. Department of the Army. Field Manual 7-98. Operations in A Low-Intensity Conflict. Washington, D.C.: Government Printing Office, Oct 1992.
- U.S. Department of the Army. Field Manual 41-10. Civil Affairs Operations. Washington, D.C.: Government Printing Office, January 1993.

- U.S. Department of the Army. Field Manual 100-7. Decisive Force: The Army in Theater Operations. Washington, D.C.: Government Printing Office, May 1995.
- U.S. Department of the Army. Field Manual 100-19. Domestic Support Operations. Washington, D.C.: Government Printing Office, July 1993.
- U.S. Department of the Army. Field Manual 100-20. Military Operations in Low Intensity Conflict. Washington, D.C.: Government Printing Office, December 1990.
- U.S. Department of the Army. Field Manual 100-23. Peace Operations. Washington, D.C.: Government Printing Office, December 1994.
- U.S. Department of the Army. Field Manual 100-23-1. HA Multiservice Procedures for Humanitarian Assistance Operations. Washington, D.C.: Government Printing Office, October 1994.
- U.S. Department of the Army. USAJFKSWCS Pub 525-5-1. Civil Affairs: A Function of Command: USAJFKSWCS White Paper. Fort Bragg, NC: U.S. John F. Kennedy Special Warfare Center and School, January 1995.
- U.S. Department of the Army. USAJFKSWCS Pub 525-5-3. Civil-Military Operations Staff Support to Army Corps and Division G5 Sections: USAJFKSWCS White Paper. Fort Bragg, NC: U.S. John F. Kennedy Special Warfare Center and School, July 1995.
- U.S. Department of the Navy. Fleet Marine Field Manual 7-34. MAGTF Civil Affairs. Joint Electronic Library. Quantica, VA: United States Marine Corps, 11 July 1991.
- U.S. General Accounting Office. Peace Operations, Heavy Use of Key Capabilities May Affect Response to Regional Conflicts. Washington, D.C.: U.S. General Accounting Office, March, 1995.

**Books:**

- Allard, Kenneth. Somalia Operations: Lessons Learned. Fort McNair, Washington D.C.: National Defense University Press, January, 1995.
- Deull, Charles B., and Laurel A. Dutcher. Working Together: NGO Cooperation in Seven African Countries. New York: Merrill, 1987.
- Dworken, Jonathan T. Military Relations with Humanitarian Relief Organizations: Observations from Restroe Hope. From Joint Electronic Library, Peace Operations CD-ROM. Alexandria, VA: Center for Naval Analysis, October 1993.
- Fishel, John T. Liberation, Occupation, and rescue: War Termination and Desert Storm. Carlisle Barracks, PA: U.S. Army War College Strategic Studies Institute, August 1992.
- Fishel, John T. The Fog of Peace: Planning and Executing the Restoration of Panama. Carlisle Barracks, PA: U.S. Army War College Strategic Studies Institute, April 1992.
- InterAction. InterAction Member Profiles. Washington, D.C.: InterAction, 1993.

Mendel, William W. and David G. Bradford. Interagency Cooperation A Regional Model for Overseas Operations. Washington, D.C.: National Defense University, 1995.

Quinn, Dennis J, Ed. Peace Support Operations and the U.S. Military. Washington, D.C.: Institute for National Strategic Studies, National Defense University, 1994.

Taw, Jennifer Morris, and John E. Peters. Operations Other Than War: Implications for the U.S. Army. Santa Monica, CA: Arroyo Center, The RAND Corporation, 1995.

#### **Journal and Magazine Articles:**

Allard, C. Kenneth. "Lessons Unlearned: Somalia and Joint Doctrine," Joint Force Quarterly Number 6 (Autumn 1995): 105-109.

Arnold, S. L. and David T. Stahl. "A Power Projection Army in Operations Other Than War." Parameters. Vol 23, No 4. (Winter 1993-1994): 4-26.

Dworken, Jonathan T. "Restore Hope: Coordination Relief Operations," Joint Force Quarterly Number 8 (Summer 1995): 14-20.

Epstein, Stephen M. and Robert S. Cronin and James G. Pulley. "JTF Haiti: A United Nations Foreign Internal Defense Mission," Special Warfare Vol. 7 Number 3 (July 1994): 2-9.

Harroff-Tavel, Marion. "Action Taken by the International Committee of the Red Cross in Situations of Internal Violence," International Review of the Red Cross (September 1993): 195-220.

Minear, Larry, and Thomas G. Weiss. "Humanitarian Politics," Headline Series Number 304 (Fall 1995): 3-72.

Natsios, Andrew S. "The International Humanitarian Response System," Parameters Volume XXV Number I (Spring 1995): 68-81.

Orr, Judith, A. "From Desert Storm to Restore Hope: The Maturing of Marine Civil Affairs," Marine Corps Gazette Volume 78 Number 10 (October 1994): 63-69.

Pitts, Darren. "Tactical Civil Affairs Planning: One Perspective for the 'Three'," Marine Corps Gazette Volume 78 Number 10 (October 1994): 64-65.

Sihra, Balbeer K. "Relief Agencies and the U.S. Military: Partners in Humanitarian Operations," Marine Corps Gazette Volume 78 Number 3 (March 1994): 43-44.

Spiro, Peter J. "New Global Communities: Nongovernmental Organizations in International Decisionmaking Institutions," Parameters Volume XXV Number I (Spring 1995): 43-54.

#### **Unpublished Dissertations, Theses, and Papers:**

Adams, Thomas K. Cooperation With Non-Military Agencies and Organizations. Briefing Slides. Fort Leavenworth KS: U.S. Army Command and General Staff College, September 1995.

- Catholic Relief Services. CRS Guidelines on Humanitarian Assistance in Conflict Situations. Harpers Ferry Workshop, April 1992.
- Farris, Karl. Support Hope After Action Review (SHAAR) Title X Issues. Briefing Slides. Carlisle Barracks, PA: U.S. Army Peacekeeping Institute, undated.
- Farris, Karl. Civil Military Operations Center. Carlisle Barracks, PA: U.S. Army Peacekeeping Institute, November 1994.
- Farris, Karl. Civil Military Operations Political-Military Considerations. Carlisle Barracks, PA: U.S. Army Peacekeeping Institute, undated.
- Germond, Thierry. "Co-Operation Between The ICRC and UNPROFOR in the Former Yugoslavia." Address given at the North Atlantic Assembly, Rose-Roth Seminar, on The Theory and practice of Peacekeeping. London: Comite International De La Croix-Rouge, 22 February 1994.
- JTF Support Hope. JTF Support Hope After Action Review. Fort Leavenworth, KS: Automated Historical Archive System, undated.
- Last, D.M. and Don Vought. Interagency Cooperation In Peace Operations: A Conference Report. Fort Leavenworth, KS: U.S. Army Command and General Staff College, 1994.
- Landis-Guzman, Lauren, et. al. NGO After Action Review of JRTC Exercise in Peace Enforcement. Fort Polk, LA: InterAction et. al., November 1993.
- Purdum, Theodore J. U.S. Army Forces Somalia. From Joint Electronic Library, Peace Operations CD-ROM. Fort Drum, NY: 10th Mountain Division, 1993.
- U.S. Army 10th Mountain Division. Multinational Force Haiti. Operation Uphold Democracy. 10th Mountain Division Operations in Haiti. Briefing Slides for the U.S. Army War College. Fort Drum, NY: U.S. Army, February 1995.
- U.S. Army Joint Readiness Training Center. Peace Operations. Briefing Slides. September 1994.
- U.S. Army Peacekeeping Institute. Support Hope After Action Review. From Joint Electronic Library, Peace Operations CD-ROM. Carlisle Barracks, PA: U.S. Army Peacekeeping Institute, 1994.
- Zvijac, David J. and Katherine A.W. McGrady. Operation Restore Hope: Summary Report. From Joint Electronic Library, Peace Operations CD-ROM. Alexandria, VA: Center For Naval Analysis, 1994.