

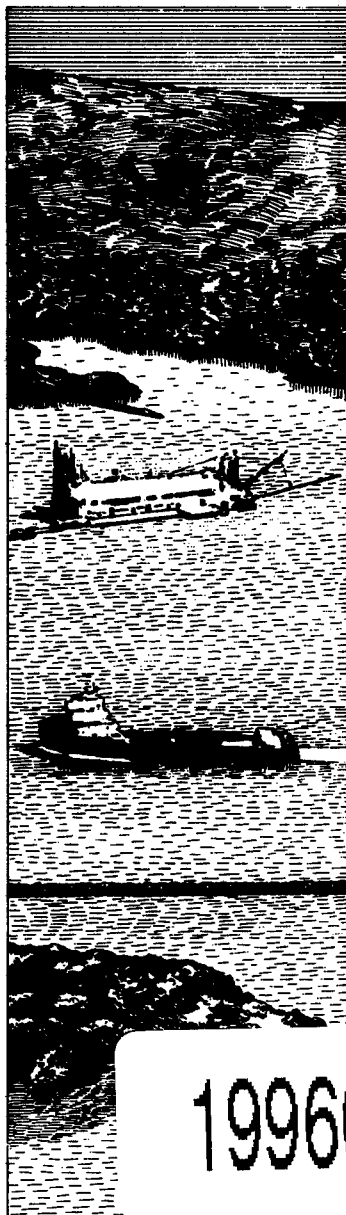

US Army Corps
of Engineers



DREDGING RESEARCH PROGRAM

TECHNICAL REPORT DRP-96-3

A GUIDE TO THE PLANNING AND HYDRAULIC DESIGN OF FLUIDIZER SYSTEMS FOR SAND MANAGEMENT IN THE COASTAL ENVIRONMENT

by

Richard N. Weisman, Gerard P. Lennon

Imbt Hydraulics Laboratory
Fritz Engineering Laboratory
Lehigh University
Bethlehem, Pennsylvania 18015

James E. Clausner

DEPARTMENT OF THE ARMY
Waterways Experiment Station, Corps of Engineers
3909 Halls Ferry Road, Vicksburg, Mississippi 39180-6199

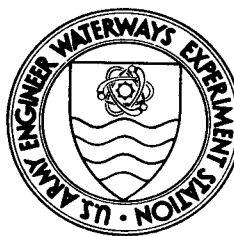

19960916 077

July 1996
Final Report

Approved For Public Release; Distribution Is Unlimited

Prepared for DEPARTMENT OF THE ARMY
U.S. Army Corps of Engineers
Washington, DC 20314-1000

Under Work Unit 32474

DTIC QUALITY INSPECTED 3



The Dredging Research Program (DRP) is a seven-year program of the U.S. Army Corps of Engineers. DRP research is managed in these five technical areas:

- Area 1 - Analysis of Dredged Material Placed in Open Water
- Area 2 - Material Properties Related to Navigation and Dredging
- Area 3 - Dredge Plant Equipment and Systems Processes
- Area 4 - Vessel Positioning, Survey Controls, and Dredge Monitoring Systems
- Area 5 - Management of Dredging Projects

The contents of this report are not to be used for advertising, publication, or promotional purposes. Citation of trade names does not constitute an official endorsement or approval of the use of such commercial products.





Dredging Research Program Report Summary



**US Army Corps
of Engineers**

Waterways Experiment
Station

A Guide to the Planning and Hydraulic Design of Fluidizer Systems for Sand Management in the Coastal Environment (TR DRP-96-3)

ISSUE: Shoaling of navigation channels is a continual problem for the Corps of Engineers. Fluidization of the shoaled material can be used to allow the shoaled sand to flow out of the channel where it can be incorporated into the littoral environment. The sandy shoal material can also be fluidized to increase the area of influence for a jet pump or submersible pump which then transfers the sand to a downdrift location. Developing guidance for the planning and hydraulic design of a fluidizer system operating in the coastal zone was the goal of this project.

RESEARCH: Existing laboratory test data were examined and additional laboratory tests were conducted to optimize hydraulic aspects of fluidizer design, including hole size, spacing, influence of slurry removal on trench geometry, etc. This information is combined

with recommendations on trench geometry needed to complete planning and design of a fluidizer project.

SUMMARY: This report describes how to plan and conduct the hydraulic design aspects of a fluidizer system used in the coastal environment.

AVAILABILITY OF REPORT: The report is available through the Interlibrary Loan Service from the U.S. Army Engineer Waterways Experiment Station (WES) Library, telephone number (601) 634-2355. National Technical Information Service (NTIS) report numbers may be requested from the WES Library.

To purchase a copy of the report, call NTIS at (703) 487-4780.

About the Authors: Dr. Richard N. Weisman is Professor of Civil and Environmental Engineering at the Imbt Hydraulics Laboratory, Lehigh University. Dr. Gerard P. Lennon is Professor of Civil and Environmental Engineering at the Fritz Engineering Laboratory, Lehigh University. Mr. James E. Clausner is Principal Investigator for this work unit at the U.S. Army Engineer Waterways Experiment Station, Coastal Engineering Research Center. Point of contact: Mr. Clausner, (601)634-2009. For further information about the DRP, contact Mr. E. Clark McNair, Jr., Manager, Dredging Research Program, at (601)634-2020.

DTIC QUALITY INSPECTED 3

A Guide to the Planning and Hydraulic Design of Fluidizer Systems for Sand Management in the Coastal Environment

by Richard N. Weisman, Gerard P. Lennon

Imbt Hydraulics Laboratory
Fritz Engineering Laboratory
Lehigh University
Bethlehem, PA 18015

James E. Clausner

U.S. Army Corps of Engineers
Waterways Experiment Station
3909 Halls Ferry Road
Vicksburg, MS 39180-6199

Final report

Approved for public release; distribution is unlimited

Prepared for U.S. Army Corps of Engineers
Washington, DC 20314-1000

Under Work Unit 32474



**US Army Corps
of Engineers**
Waterways Experiment
Station

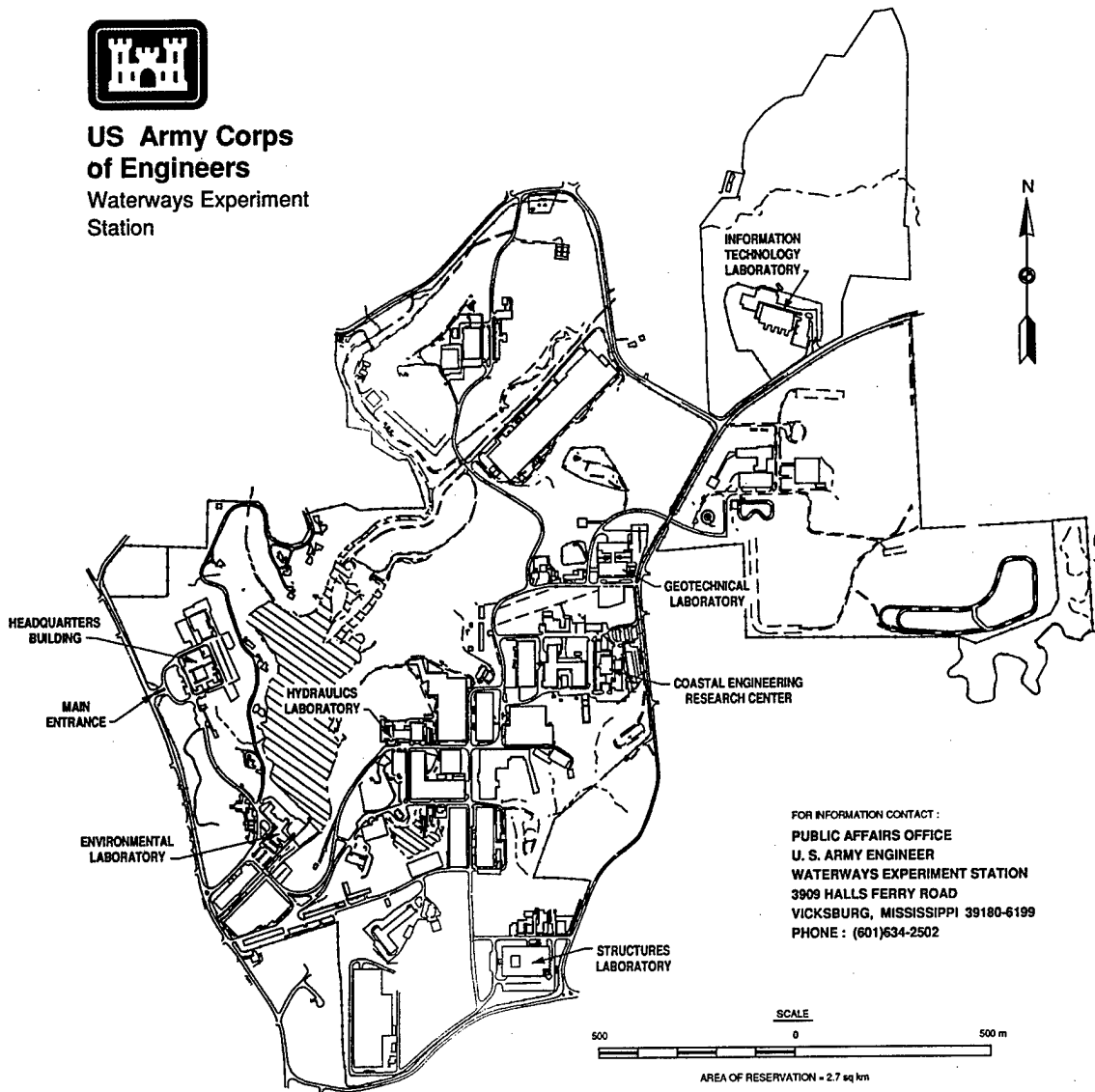

FOR INFORMATION CONTACT:
PUBLIC AFFAIRS OFFICE
U. S. ARMY ENGINEER
WATERWAYS EXPERIMENT STATION
3909 HALLS FERRY ROAD
VICKSBURG, MISSISSIPPI 39180-6199
PHONE : (601)634-2502

Waterways Experiment Station Cataloging-in-Publication Data

Weisman, Richard Nathan, 1945-

A guide to the planning and hydraulic design of fluidizer systems for sand management in the coastal environment / by Richard N. Weisman, Gerard P. Lennon, James E. Clausner ; prepared for U.S. Army Corps of Engineers.

94 p. : ill. ; 28 cm. -- (Technical report ; DRP-96-3)

Includes bibliographic references.

1. Fluidization -- Planning. 2. Bulk solids flow -- Planning. 3. Dredging. 4. Coastal zone management. I. Lennon, Gerard P. II. Clausner, James E. III. United States. Army. Corps of Engineers. IV. U.S. Army Engineer Waterways Experiment Station. V. Dredging Research Program (U.S.) VI. Title. VII. Series: Technical report (U.S. Army Engineer Waterways Experiment Station) ; DRP-96-3.

TA7 W34 no.DRP-96-3

Contents

Preface	ix
Conversion Factors, Non-SI to SI Units of Measurement	x
Summary	xi
1—Introduction	1
Fluidization Phenomena	1
Site Assessment Studies	2
Use of Fluidizers for Bypassing	5
Use of Fluidizers for Channel Maintenance	8
2—Fluidizer Pipe Design	10
Introduction	10
Hole Orientation	12
Flow Rate	13
Pressure Requirements in Fluidizer Pipe	17
Hole Size and Spacing	20
Pipe Size	20
Miscellaneous Constraints	21
3—Elements of a Fluidizer System	23
Pipe Materials	23
Clear Water Supply	24
Pump Requirements, Clogging, and Hole Wear	24
Debris Accumulation in Trench	26
Operating Time	27
Installation of Fluidizer Pipe	29
4—Summary of Design Procedure	31
Example 1: Navigable Channel Maintenance	33
Example 2: Sand Bypassing	40
References	48

Appendix A: Pipe Size Design	A1
Appendix B: Fluidizer Experience at the Oceanside Sand Bypass Plant	B1

SF 298

List of Figures

Figure 1.	Five stages of fluidization	3
Figure 2.	Fluidizer pipe used in conjunction with a fixed slurry pump	7
Figure 3.	Cross-sectional view of a fluidizer pipe through a sandbar used for channel creation and maintenance	8
Figure 4.	Plan view schematic of the components of a fluidizer system used in a tidal inlet in conjunction with a jet or slurry pump	9
Figure 5.	Definition sketch of a fluidizer pipe after trench formation	11
Figure 6.	Horizontally opposed hole configuration spaced a distance ΔX along the pipe	12
Figure 7.	Chart for isotropic conditions providing required incipient flow-rate factor (Q_I/Kd_b) versus relative burial depth (d_b/D) for inspected domain sizes	15
Figure 8.	Experimental trench geometry with and without cobbles present in sand	27
Figure 9.	Formation of a sand "dam" near the downstream end of the fluidization pipe when slurry was not removed in an experiment on a beach face	28
Figure 10.	Elevation and plan views of modular fluidizer pipe and stand pipe configuration used at Lake LaVista Channel, Anna Maria, Florida	30
Figure 11a.	Hypothetical site location for Example 1, showing inlet, jetties, shoreline, and depth contours	34
Figure 11b.	Cross-section AA' showing location of fluidizer pipe and initial and final channel bottom for Example 1	35

Figure 12.	Cross-section view perpendicular to and at the end of the inlet jetties showing fluidizer pipe, trench location, and initial and final channel bottom for Example 1	36
Figure 13.	Cross-section view of alternative configuration of two parallel fluidizer pipes for Example 1	37
Figure 14.	Cross-section view of alternative fluidizer configuration for Example 1; a longer pipeline is used than the base case shown in Figure 11b	37
Figure 15.	Sand bypassing site location, Santa Barbara Harbor, used for Example 2	41
Figure 16.	Sediment budget for Santa Barbara Harbor	42
Figure 17a.	Location of fluidizer system using the fixed bypass plant alternative showing general location	43
Figure 17b.	Location of fluidization system components	44
Figure 18.	Section and plan views showing relative location of jet pump crater and fluidizer pipes, sandbar, pump house, and clear water intake	45
Figure A1.	Fluidizer pipe showing holes and sections 1 and 2 where the energy equation is applied to determine pipe diameter	A1
Figure A2.	Variation of pressure head from center-feed pressure head inside and along fluidization pipe, Example 1	A7
Figure A3.	Variation of pressure head from center-feed pressure head inside and along fluidization pipe, Example 2	A11
Figure B1.	Location map, Oceanside sand bypass system	B2
Figure B2.	Oceanside Harbor structures	B3
Figure B3.	Bypass system locations	B4
Figure B4.	Phase II fluidizer locations	B7
Figure B5.	Clamps used to attach fluidizer pipes to support piles	B9
Figure B6.	Projected fluidizer trench dimensions	B11
Figure B7.	South jetty jet pump showing strongback and pivot point	B12
Figure B8.	Fluidizers and cross-section locations	B14

Figure B9.	Bottom profile along the centerline of the north sand trap fluidizer, December 1991	B16
Figure B10.	Bottom profile along the centerline of the south sand trap fluidizer, December 1991	B17
Figure B11.	Planned modifications for Phase III of the Oceanside Sand Bypass System	B19

List of Tables

Table 1.	Typical Range of Values of Angle of Repose of Various Materials	11
Table 2.	Results of Experiments Using Various Hole Sizes, Holes Spaced 2 in. Apart	14
Table 3.	Results of Experiments Using Various Hole Spacings, Hole Size of 1/8 in.	14
Table 4.	Variation of Head Loss Divided by Depth of Burial (h_{max}/d_b) for the Simulated Conditions (1/8-in. Holes on 2-in. Centers in a 1-ft-Diameter Pipe) for Incipient Fluidization	18
Table A1.	Pipe Properties, Example 1	A3
Table A2.	Reynolds Numbers and Friction Factors, Example 1	A5
Table A3.	Pressure Head Changes, Example 1	A6
Table A4.	Pipe Properties, Example 2	A8
Table A5.	Reynolds Numbers and Friction Factors, Example 2	A9
Table A6.	Pressure Head Changes, Example 2	A10
Table B1.	Phase I Production History	B5
Table B2.	Oceanside Phase II Sand Trap Fluidizers Dimensions	B6
Table B3.	Oceanside Sand Trap Fluidizer Hydraulic Design Data	B7
Table B4.	Oceanside Experimental Sand Bypass System - Phase II Production Summary	B13

Preface

This report was prepared for the U.S. Army Engineer Waterways Experiment Station (WES) under Dredging Research Program (DRP) Technical Area 3, Work Unit Number 32474, "Improved Eductors for Sand Bypassing." The DRP is sponsored by Headquarters, U.S. Army Corps of Engineers (HQUSACE). HQUSACE Technical Monitor for Technical Area 3, Dredge Plant Equipment and Systems Processes, was Mr. Gerald Greener.

This report was written by Drs. Richard Weisman and Gerard Lennon, Lehigh University, Bethlehem, PA, and Mr. James Clausner, WES. Technical oversight was provided by Mr. Clausner, Principal Investigator, Coastal Structures and Analysis Branch, Engineering Development Division, Coastal Engineering Research Center (CERC), WES. Mr. E. Clark McNair, Jr., and Dr. Lyndell Z. Hales were Manager and Assistant Manager, respectively, of the DRP. Dr. James R. Houston and Mr. Charles C. Calhoun, Jr., were Director and Assistant Director, respectively, of CERC, which conducted the DRP. Review of Appendix B, "Fluidizer Experience at the Oceanside Sand Bypass System," by Mr. Joseph Ryan, U.S. Army Engineer District, Los Angeles, is much appreciated.

At the time of publication of this report, Dr. Robert W. Whalin was Director of WES. COL Bruce K. Howard, EN, was Commander.

For further information concerning this report, contact Mr. James Clausner, (601) 634-2009, or Mr. E. Clark McNair, Jr., (601) 634-2070.

The contents of this report are not to be used for advertising, publication, or promotional purposes. Citation of trade names does not constitute an official endorsement or approval for the use of such commercial products.

Conversion Factors, Non-SI to SI Units of Measurement

Non-SI units of measurement used in this report can be converted to SI units as follows:

Multiply	By	To Obtain
cubic feet per second	0.02831685	cubic meters per second
cubic yards	0.7645549	cubic meters
degrees (angle)	0.01745329	radians
feet	0.3048	meters
gallons per minute	0.00006309020	cubic meters per second
miles (U.S. statute)	1.609347	kilometers
pounds per square inch	6.89476	kilopascals

Summary

This report provides guidance for the planning and hydraulic design of fluidizer systems for sand management in the coastal environment. Fluidization, the injection of fluid into a granular medium (typically sand), causes the grains to lift and separate. Once the granular bed has been fluidized it behaves as a dense fluid and can be made to flow to a desired location. Over the last decade, research on fluidization of sand at tidal inlets and harbor mouths has been undertaken to utilize fluidization for maintenance of navigable waterways (the fluidized shoal is directed out of the channel) and for use in sand bypassing (the fluidized shoal is directed to a submersible pump or jet pump).

The main emphasis in the report is on the design of the fluidizer pipe itself; some suggestions concerning other aspects of a system are also offered. The approach presented is based primarily on laboratory research conducted to understand fluidization phenomena in two and three dimensions. The effects of various design parameters on fluidization and trench formation have been assessed. At this time, there have been few field installations from which to gather information; however, the small amount of field experience has been included as much as possible and to the extent that the authors have access to information on the field installation.

The design objective for a fluidization system is primarily to create a trench of a given cross section and length. To obtain a trench, complete fluidization must be achieved. The two basic parts of the design must entail the hydraulic aspect to attain full fluidization and a geometric element to obtain a desired trench geometry. Basic research over the past decade has helped define these two crucial aspects.

The last section of the report contains two design examples. The first example employs a fluidizer pipe to establish and maintain a navigable channel in a tidal inlet. The second example involves the use of a fluidizer pipe in conjunction with sand bypassing.

1 Introduction

Fluidization is a process in which fluid is injected into a granular medium (typically sand) causing the grains to lift and separate. Historically, applications of fluidization have been in chemical and sanitary engineering for combustion processes, mass and heat exchange, and backwashing of sand filters. Over the last decade, research on fluidization of sand at tidal inlets and harbor mouths has been undertaken to utilize fluidization for maintenance of navigable waterways and for use in sand bypassing.

This report provides guidance in the design of fluidizer systems for use in both channel maintenance and sand bypassing. The main emphasis is on the design of the fluidizer pipe itself; some suggestions concerning other aspects of a system are also offered. The approach presented here is based primarily on laboratory research conducted to understand fluidization phenomena in two and three dimensions. The effects of various design parameters on fluidization and trench formation have been assessed. At this time (1996), there have been few field installations from which to gather information; however, the small amount of field experience has been included as much as possible and to the extent that the authors have access to information on the field installation.

The design objective for a fluidization system is primarily to create a trench of a given cross section and length. To obtain a trench, complete fluidization must be achieved. The two basic parts of the design must entail (a) the hydraulic aspect to attain full fluidization, and (b) a geometric element to obtain a desired trench geometry. Basic research over the past decade has helped define these two crucial aspects.

Chapter 4 contains two design examples. The first example employs a fluidizer pipe to establish and maintain a navigable channel in a tidal inlet. The second example involves the use of a fluidizer pipe in conjunction with sand bypassing.

Fluidization Phenomena

In the applications discussed here, water is pumped into a perforated pipe buried beneath the sand. Initially water is pumped into the pipe and exits from the perforations at a low flow rate that does not disrupt the fixed bed (see Figure 1a). For the relatively small sand sizes normally found near tidal inlets

(mean diameter 0.5 mm or less), the velocity through the sand will be low enough that Darcy-type (laminar) flow will occur up to initiation of fluidization (Lennon, Chang, and Weisman 1990). As the flow rate is increased, isolated pockets of disrupted sand migrate upward (see Figure 1b). Initiation of fluidization occurs when a spout or boil occurs along this weakened path from the pipe to the surface. However, the whole region along the length of the pipe is not fluid at this stage. By further increasing the flow rate, complete or full fluidization occurs when the whole region along the pipe is fluidized (Figure 1c). This region is rather narrow and confined by berms at the sand surface formed by sand ejected from the fluidized zone. Figures 1a to 1c depict the process from pre-initiation to full fluidization.

Once the region above the pipe is completely fluidized, the slurry can be easily removed by pumping or gravity flow. As slurry is removed, the fluidized region begins to widen into a trench as shown in Figure 1d. If the flow rate and slurry removal are stopped before all the slurry is removed, the sand in the fluidized zone will settle and some additional slumping will occur, creating a trench partially down to the source pipe. If the flow rate and slurry removal are continued, the berms and sides of the fluidized region slump inward (Figure 1d) until an equilibrium is reached in two areas of the trench cross section. In the region close to the pipe, scour holes form (Figure 1e). In the area further up the sides away from the pipe, the sand lies at the submerged angle of repose of the material. In summary, the fluidization process contains the following stages: prefluidization, initial fluidization, complete fluidization, trench formation during slurry removal, and final trench configuration. If most but not all of the fluidized material is removed, the final geometry will lie between that shown in Figures 1d and 1e, although some additional slumping occurs when the flow is stopped and the fluidized zone consolidates to a smaller volume of unfluidized sand on top of the pipe.

Site Assessment Studies

Design of a fluidizer system for either channel maintenance or bypassing requires an understanding of the coastal processes of the site. At least one year of data collection is needed to appreciate the seasonal variations associated with coastal phenomena, and three years of data collection are desirable.

The design of any coastal facility, including a fluidization system, should begin with an office phase followed in most cases by a field investigation if available information is insufficient (*Shore Protection Manual* (SPM) 1984). The first step in the office phase is to review existing data and begin the design process. If additional data are needed, some elements of the design can be undertaken while the field investigation is being initiated.

Information on conducting coastal studies is beyond the scope of this report. However, many good references are available, such as the SPM (1984) and EM 1110-2-1616 (U.S. Army Corps of Engineers 1991). The coastal processes

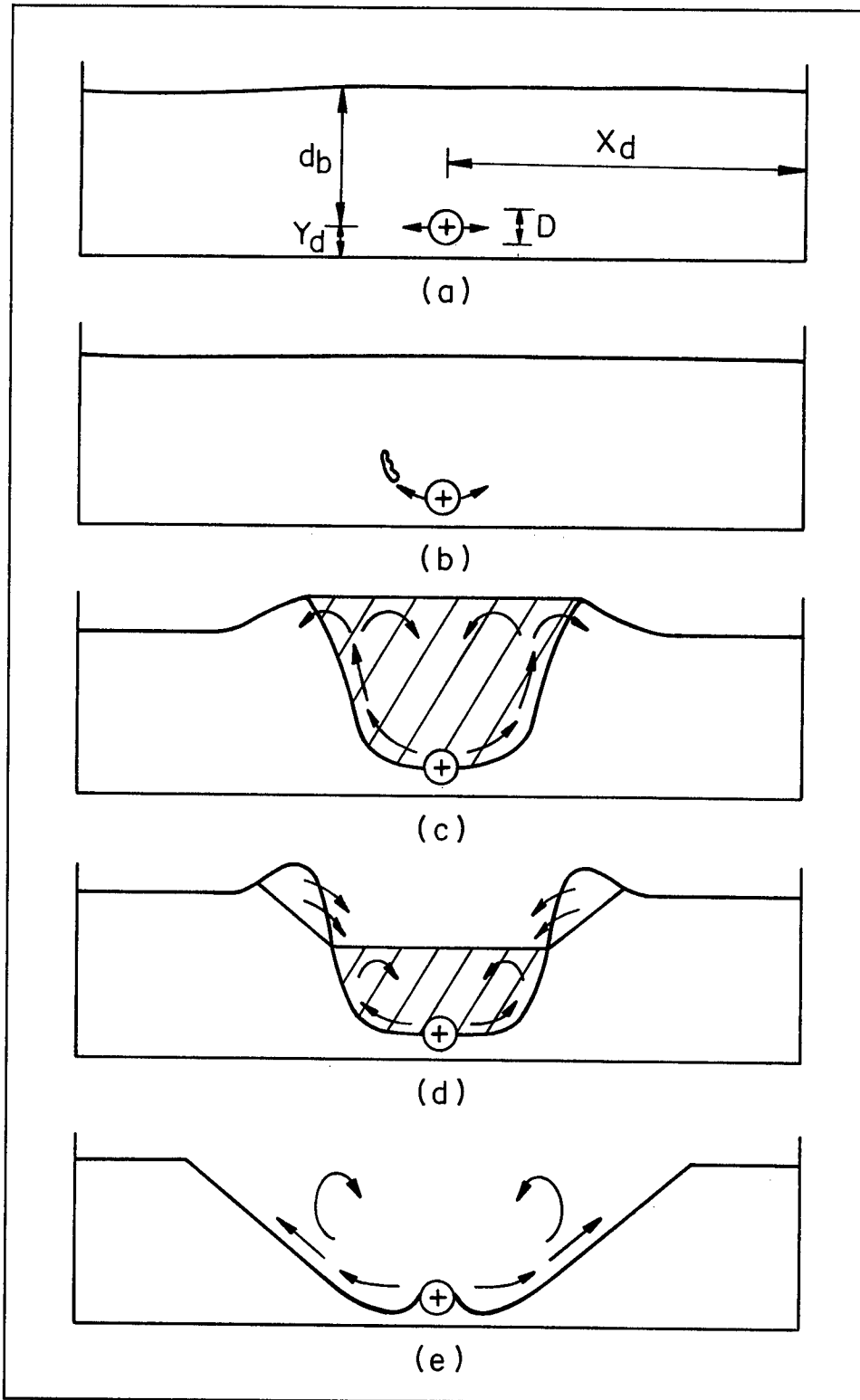

Figure 1. Five stages of fluidization: (a) prefluidization, (b) immediately prior to incipient fluidization, (c) full fluidization, (d) slurry removal during full fluidization causing side slumping, and (e) jet erosion following complete slurry removal. Hatched area shows fluidized zone

of particular importance for a fluidizer system design, either for channel maintenance or bypassing, are listed below:

- a. *Littoral transport.* Both direction and rate of transport must be assessed to estimate the rate of infilling of the trench. This will determine the frequency of operation required and the rate of disposal.
- b. *Sediment characteristics.* Several sediment characteristics are required for fluidizer design. These include:
 - (1) Grain size distribution.
 - (2) Specific gravity.
 - (3) Presence of cohesive materials.
 - (4) Presence of debris.
- c. *Morphology.* A detailed survey of nearshore or inlet bathymetry is required. Also, core samples must be obtained to assess depth and areal extent of sand and to determine if debris or fine materials are present.
- d. *Waves, currents, tides.* A general understanding of these parameters at the site is required for the proper layout of system components. For the channel maintenance design problem, the tidal hydraulics of the inlet or harbor mouth are required, especially if the slurry removal mechanism must rely on tidal currents, as described later.

Because sediment characteristics are of special importance in designing a fluidization system, several aspects concerning sediments are expanded upon here:

- a. To determine sediment characteristics, a sediment sampling program will be required. SPM (1984) and Eckert and Callender (1987) provide information on conducting such sampling programs. Sediment sampling can include near surface, borings, or cores. Because the fluidization system will often be buried 10 to 30 ft¹ below the shoaled bed elevation, information on the sediment at or below this depth will aid in the design. Some of this information may already be available from previous dredging studies and/or geotechnical investigations for stabilization structures (e.g., jetties).
- b. The composition of sediments located in coastal areas is normally dominated by quartz sand, although shells and shell fragments may also be present. Repeated refluidization events may remove the very fine quartz sand and other fine materials, but the larger material may not migrate completely out of the trench and may accumulate over time. Because sand

¹ A table of factors for converting non-SI units of measurements to SI units is provided on page x.

in the fluidized region will be removed, in addition to studying the in situ sand, the material that is expected to fill the trench must be determined for refluidization once the trench has filled in. If dredging has already occurred, the nature of the sand that has infilled the dredged area will be known, and may be of different composition than the undisturbed material. The newly deposited sand will be compacted by wave loading, but will be less compacted than the undisturbed sand adjacent to the dredged area.

- c. The sediment samples should be subjected to geotechnical tests to determine the grain size distribution and grain shape, and to permeameter tests to determine the coefficient of permeability (hydraulic conductivity), K . Estimates of K can also be made from grain size distributions. Procedures for estimating K are available from many sources, such as Eckert and Callender (1987).

The design of a fluidizer system also requires information about other site-specific items, such as:

- a. Nearby structures (jetties, walls) and topographic features.
- b. Description of possible receiving areas for bypassed sediment and routes for pipelines.

Use of Fluidizers for Bypassing

Littoral sediment can be trapped or impounded at both natural and man-made obstructions along the coast. Notable among these are inlets and harbor mouths. When inlets and harbor mouths have shoaling problems and/or downdrift beaches erode because of an interruption in sand supplied by littoral processes, sand bypassing can help to mitigate these adverse effects.

A number of alternative sand bypassing methods have been suggested in the literature (Richardson and McNair 1981), including:

- a. Floating dredges.
 - (1) Trailing suction hopper.
 - (2) Cutter suction.
 - (3) Bucket ladder.
- b. Land-based mechanical equipment.
 - (1) Dragline.
 - (2) Clamshell.

- (3) Backhoe.
- c. Hydraulic equipment.
 - (1) Dredge pump.
 - (2) Jet pump.
 - (3) Other solids-handling pumps.

With all of these devices, sand is taken from the area of accumulation (shoal or fillet) and delivered to the downdrift shore.

Sand bypassing methods can also be classified according to their mobility (Richardson and McNair 1981).

- a. *Fixed systems* are tied to a fixed location; e.g., a jet pump attached to a fixed platform or jetty.
- b. *Mobile systems* can move from location to location; e.g., a floating dredge or a jet pump attached to a moveable crane.
- c. *Semimobile systems* have limited mobility and can operate over a restricted area; e.g., a jet pump mounted on a pivoting system.

The use of a fluidizer pipe in sand bypassing is most useful in extending the range of a fixed system. The quantity of sediment that a fixed system can bypass is a function of the sand supplied by littoral transport. In particular, a jet pump or submersible pump creates a crater of fairly limited extent and an operator must wait until the crater refills with sand supplied by littoral processes before resuming pumping. A fluidizer pipe used in conjunction with a fixed slurry pump can create a long (typically 100-ft to 400-ft) trench, a sand trap across the whole littoral zone, and supply slurry to the pump crater (Figure 2).

The basic components required for the systems are (see Figure 2):

- a. One or more fluidizer pipes sloping toward the jet pump crater. (See Chapter 2 for fluidizer pipe design and Chapter 3 for pipe materials.)
- b. Water supply pipelines to each fluidizer pipe to carry clear water.
- c. Pumps to provide clear water to the fluidizer pipes (Chapter 3).
- d. Intake facility to ensure that pumps carry clear water to the fluidizer pipes to avoid clogging of holes (Chapter 3).
- e. Supply pump for the jet pump (Richardson and McNair 1981).
- f. Supply pipeline for the jet pump (Richardson and McNair 1981).

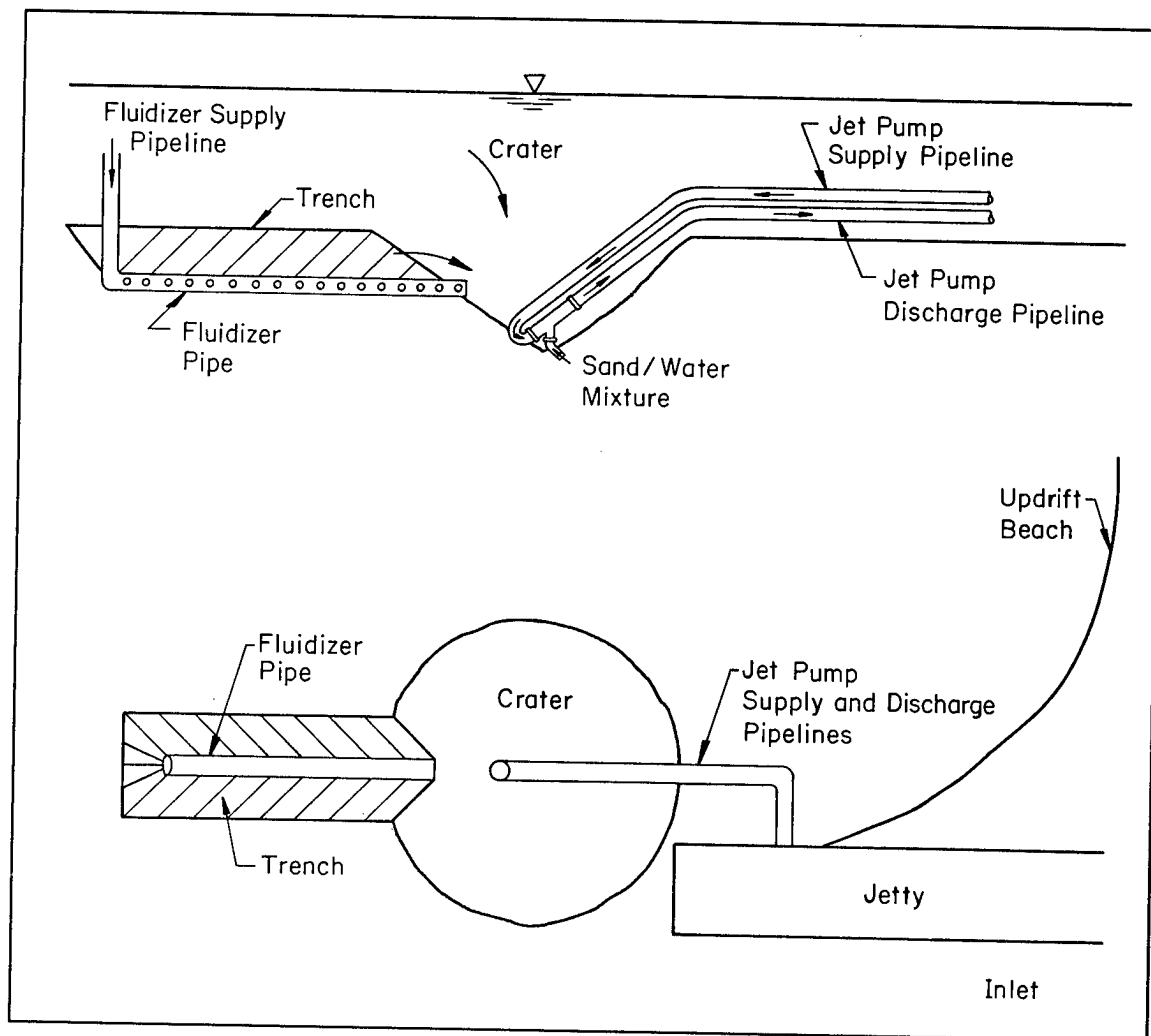

Figure 2. Fluidizer pipe used in conjunction with a fixed slurry pump; hatched area indicates fluidized zone

- g. Discharge pipeline from the jet pump (Richardson and McNair 1981).
- h. Booster pump and discharge pipeline to deliver slurry to some distant discharge point (Richardson and McNair 1981).

The siting and layout considerations for use of a fluidizer pipe in sand bypassing are similar to those discussed by Richardson and McNair (1981). The reader is referred to that report for a thorough discussion of items such as (a) interaction of trench and crater with coastal structures including stability and foundation support considerations, (b) location of shore-based equipment, (c) location of jet or slurry pumps, and (d) location for discharge of slurry. In particular, much of the discussion on siting of jet pump arrays in Richardson and McNair (1981) is pertinent to fluidizer pipes as well.

Use of Fluidizers for Channel Maintenance

The trench created by removal of slurry from the fluidized region above a fluidizer pipe can be used to stabilize and maintain a navigable channel. If the pipe is placed sufficiently deep or if two or more pipes are placed in parallel, the trench dimensions that can be achieved can satisfy the navigation requirements of small, shallow draft vessels.

The most likely applications of fluidizers for channel maintenance are shoals at tidal inlets and harbor mouths (Figure 3). A fluidizer pipe set across, but under, the ebb tidal bar can create a channel through it.

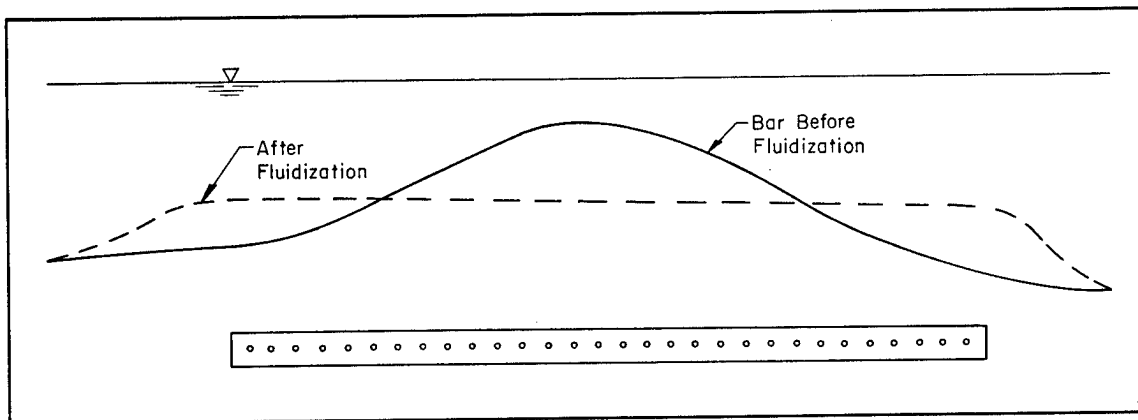

Figure 3. Cross-sectional view of a fluidizer pipe through a sandbar used for channel creation and maintenance

Once fluidized, the slurry in the fluidized region must be removed in order for the trench to form. For channel formation and maintenance, there are three possible removal mechanisms.

- a. *Pumping* the slurry out of the trench and placing it on a downdrift beach, as in bypassing.
- b. *Current* created by a strong overlying ebb flow can entrain the slurry and carry it out of the trench.
- c. *Gravity flow* of the slurry to carry the sediment out of the trench, perhaps in the seaward and landward directions.

For channel maintenance, the fluidizer pipe (or parallel pipes) extends along the centerline of the navigation channel (Figure 4). The configuration for a channel maintenance system can take on various forms depending on the slurry removal mechanism. Figure 4 shows a system in which fluidized sand is removed by a submerged pump and delivered to a downdrift beach. The components of this system are similar to the components required for bypassing.

For a system that relies on gravity flow and/or ebb current for slurry removal, only the components associated with the fluidization pipe are required.

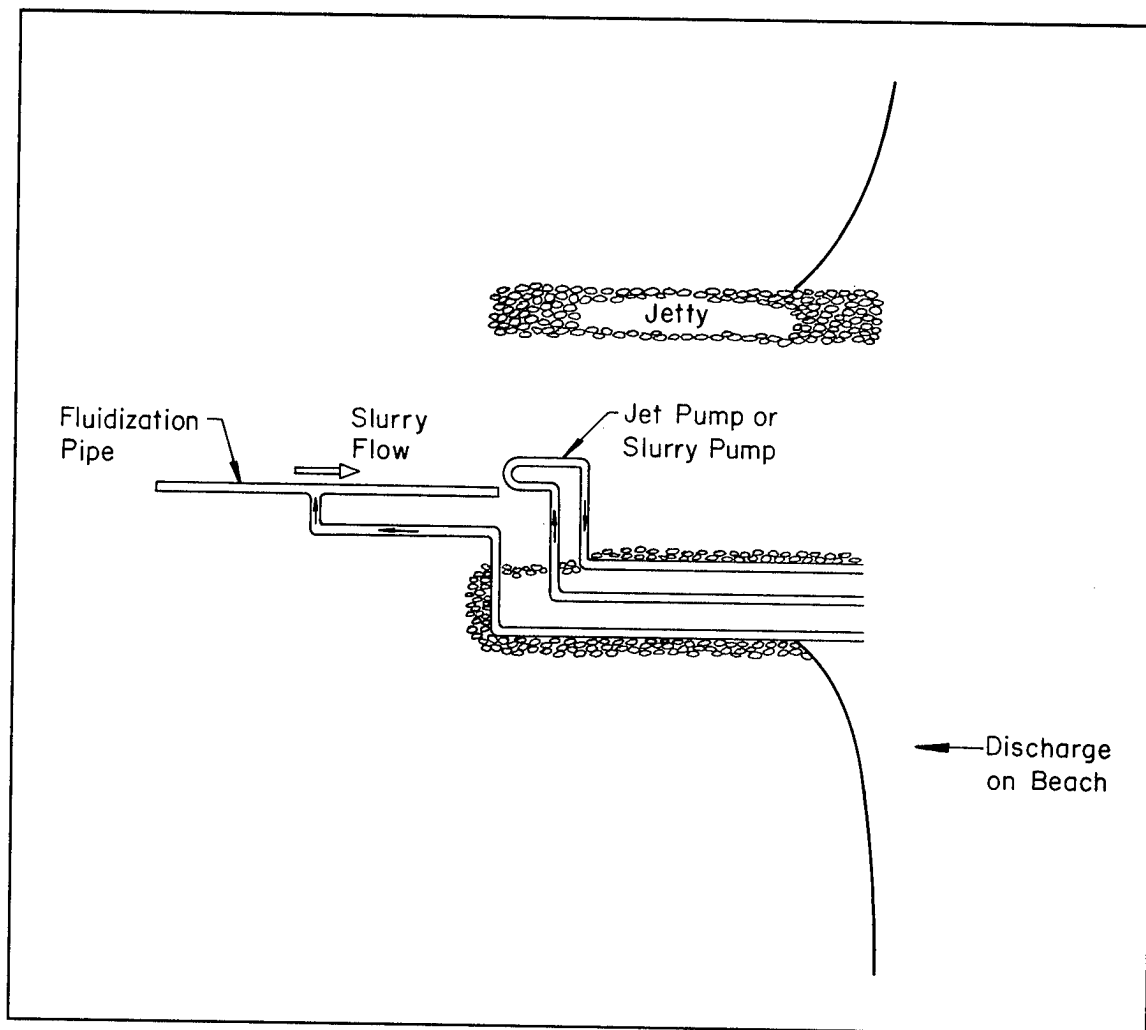

Figure 4. Plan view schematic of the components of a fluidizer system used in a tidal inlet in conjunction with a jet or slurry pump

2 Fluidizer Pipe Design

Introduction

This chapter provides guidance on selecting the main parameter values associated with a fluidizer pipe. References are provided to allow the designer access to the background literature upon which this design guidance is based. The parameters considered are:

- a. Hole orientation.
- b. Flow rate.
- c. Pressure requirements in fluidizer pipe.
- d. Hole size and spacing.
- e. Pipe size.

The goal of fluidization in the coastal environment is to create a trench. Trench size and location are the first considerations in the design process. The major geometrical elements of a trench, which include length and cross-section geometry, are shown in Figure 5.

- a. The designer must determine the required length of trench L , which can be the length of an ebb tidal bar for maintenance of a navigation channel or the width of the littoral zone for sand bypassing.
- b. If the pipe is buried to a depth d_b (or placed in a predredged area and allowed to shoal to a depth d_b), a conservative estimate of the top width T can be approximated by $2d_b/\tan \phi$ where ϕ is the angle of repose. Table 1 gives values of ϕ for various materials from several reference sources.
- c. The bottom width B includes the diameter of the pipe plus the width of the scour holes created by the fluidizer jets. The top width T is exactly $B + 2d_b/\tan \phi$. Because the scour hole widths are a small fraction of the total top width T , if burial depth is greater than a few feet, ignoring B provides a slightly conservative estimate of top width.

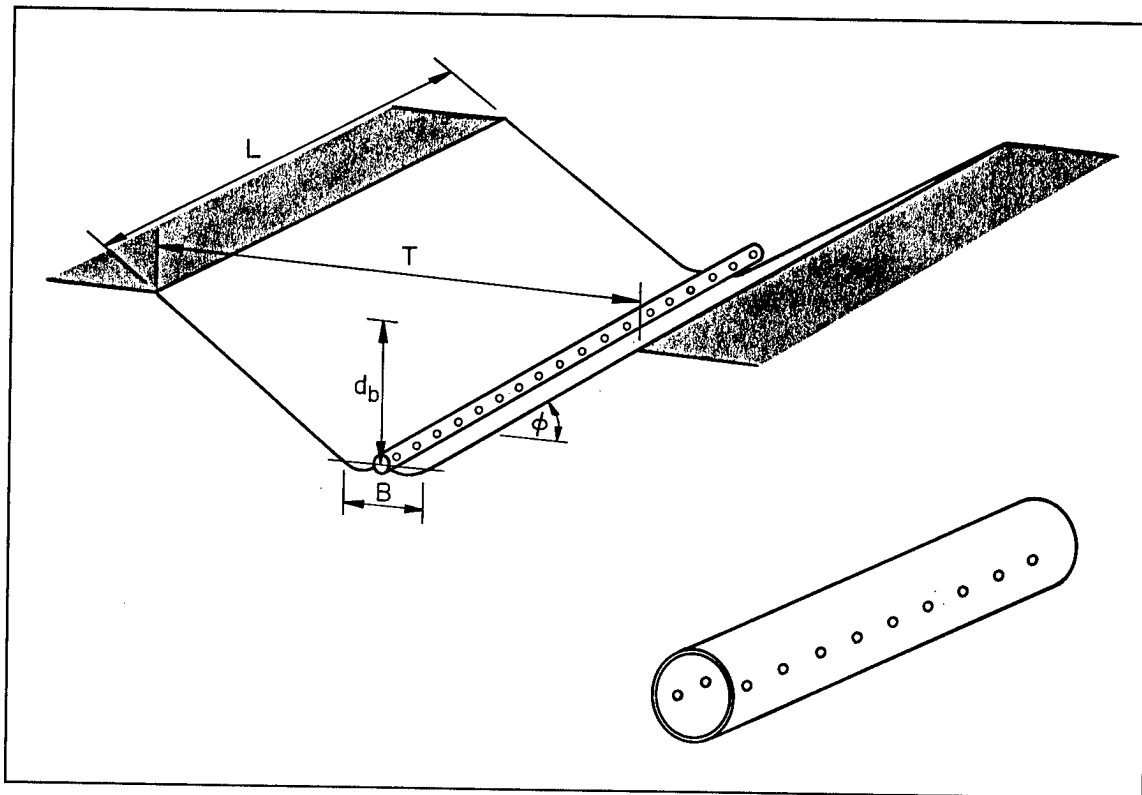

Figure 5. Definition sketch of a fluidizer pipe after trench formation

Table 1 Typical Range of Values of Angle of Repose of Various Materials		
Soil	Angle of Repose, ϕ	
	Loose	Dense
Sand, angular	32 - 36°	35 - 45°
Sand, beach (well rounded)	28 - 32	32 - 38
Gravel, bank run	34 - 38	38 - 42
Silty sand	25 - 35	30 - 36
Silt, inorganic	25 - 35	30 - 35

- d. To achieve movement of sediment along the trench, the pipe should be sloped. For sand bypassing the trench is required to slope toward the excavating pump at about a 0.5 to 2.0 percent slope; hence, the fluidizer pipe should be set to the same slope. For channel maintenance, the pipe will usually be set through the ebb tidal bar. From the field investigation, the bathymetry, including seasonal variations, will be determined. The pipe location is chosen so that the elevation of the seaward end of the pipe is lower; a slope of 0.5 to 2.0 percent is recommended.

Once the designer determines the trench size desired, selection of the flow and pipe parameters to achieve that trench size can proceed.

Hole Orientation

Hole orientation is the next logical design parameter to select. Based on the experiments of Kelley (1977) and the work of Weisman and Collins (1979) and Weisman, Collins, and Parks (1982), hole orientation is recommended to be horizontally opposed as shown in Figure 6. The reasons for this are twofold:

- a. Kelley (1977) showed that the widest fluidized region is achieved with horizontally opposed holes.
- b. Weisman and Collins (1979) reasoned that a pipe with upward pointing holes would tend to fill with sand when not in use and a pipe with downward pointing holes would tend to self-bury.

All subsequent work (after 1979) on fluidization at Lehigh University used horizontally opposed holes.

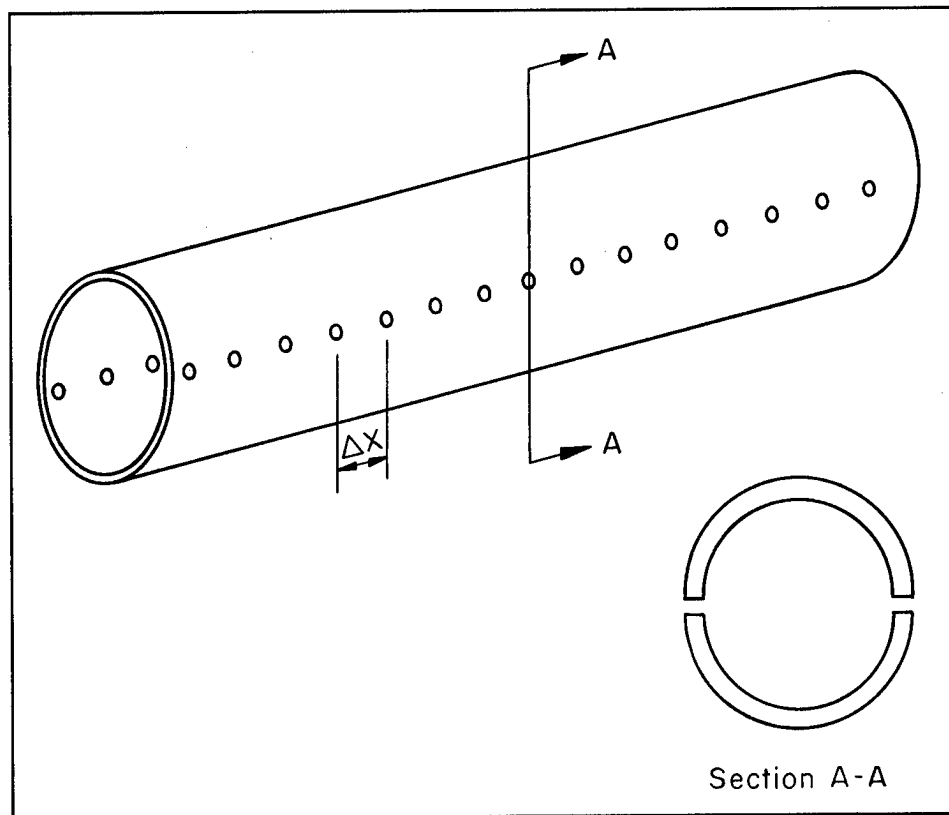

Figure 6. Horizontally opposed hole configuration spaced a distance ΔX along the pipe

Flow Rate

For horizontally opposed holes, research has been conducted to determine the flow rate required to achieve initial and full fluidization. This has been done experimentally using two sand sizes (mean diameters of 0.15 and 0.45 mm), two bed depths (25.4 and 42.0 cm), four different hole sizes (1/16, 1/8, 3/16, and 1/4 in.) spaced 2 in. apart, and four hole spacings (1, 2, 3, and 4 in.) all with 1/8-in. hole size. The research is described in detail in Weisman, Roberts, and Lennon (1988); Weisman, Clifford, and Lennon (1990); Weisman, Demchak, and Lennon (1991); and Ledwith, Weisman, and Lennon (1990).

The flow rate required for initial fluidization primarily depends on sand size and depth. Hole spacing and hole size have little effect on the flow rate requirement for initiation of fluidization. This finding is consistent with three-dimensional simulations by Lennon and MacNair (1991) using a numerical groundwater flow model; variations in flow patterns along the pipe are restricted to a region within a few inches of the holes and the simulated incipient flow rate is virtually the same for all hole spacings and sizes tested. A higher simulated pipe pressure is required for the smaller hole sizes and wider spacing, also consistent with the experiments. Experimental values conducted on hole size and spacing are shown in Tables 2 and 3, respectively. Note that these flow rates are flows per unit length of fluidization pipe. Tables 2 and 3 represent the results of the different investigators. Because of differences in the manner in which the bed was compacted as well as interpreting when full fluidization occurred, the results in Tables 2 and 3 for 1/8-in. hole size and 2-in. hole spacing are somewhat different.

To obtain flow rates required to initiate fluidization in bed depths greater than 42.0 cm (and any practical design case will have bed depths greater than 42.0 cm), a mathematical model was developed by Lennon, Chang, and Weisman (1990). Figure 7, the result of this model, is a plot of relative burial depth (burial depth divided by pipe diameter) versus a flow rate factor, Q'_i/Kd_b , where K is the coefficient of permeability of the sand, d_b is the bed depth, and Q'_i is the flow rate per foot of pipe length. The third parameter required to use this plot is the sand domain size, X_d/D , Y_d/D , where X_d and Y_d are the horizontal distance from the pipe to the limits of the sand and the depth of the sand layer below the pipe, respectively (see Figure 1a).

The analysis of Lennon, Chang, and Weisman (1990) indicates that the required flow rate per foot of pipe length for incipient fluidization Q'_i is linearly dependent on coefficient of permeability, is less than linearly dependent on burial depth, and is not highly sensitive to the horizontal and vertical extent of the permeable sediments. Although for one-dimensional analyses the incipient flow rate is independent of burial depth, the Lennon, Chang, and Weisman (1990) analysis indicates a dependence due to two-dimensional and three-dimensional effects as shown in Figure 7. The burial depth d_b will be known from the design process. However, the coefficient of permeability K for different coastal sediments can vary by orders of magnitude and, hence, is an important part of the design process. For the fine sand found at most coastal

Table 2
Results of Experiments Using Various Hole Sizes, Holes Spaced
2 in. Apart

Hole Size in.	Sand Depth cm	Sand Size mm	Initiation Flow Rate, Q_i ft ³ /sec/ft	Full Fluid- ization Flow Rate, Q_f ft ³ /sec/ft	$F = Q_f/Q_i$	Pressure Head in Pipe, ft ¹
1/16	25.4	0.15	1.34×10^{-3}	5.72×10^{-3}	4.3	17.31
1/8	25.4	0.15	0.81×10^{-3}	9.44×10^{-3}	11.6	
3/16	25.4	0.15	0.92×10^{-3}	21.19×10^{-3}	23.0	
1/4	25.4	0.15	0.78×10^{-3}	13.06×10^{-3}	16.8	3.28
1/16	42.0	0.15	2.26×10^{-3}	7.06×10^{-3}	3.1	28.40
1/8	42.0	0.15	1.84×10^{-3}	10.94×10^{-3}	6.0	6.81
3/16	42.0	0.15	1.73×10^{-3}	13.77×10^{-3}	8.0	
1/4	42.0	0.15	2.49×10^{-3}	22.25×10^{-3}	8.9	3.28
1/16	25.4	0.45	9.71×10^{-3}	16.77×10^{-3}	1.7	109.75
1/8	25.4	0.45	10.42×10^{-3}	19.67×10^{-3}	1.9	11.27
3/16	25.4	0.45	10.59×10^{-3}	28.60×10^{-3}	2.7	5.40
1/4	25.4	0.45	8.83×10^{-3}	13.24×10^{-3}	1.5	3.39
1/16	42.0	0.45	14.83×10^{-3}	16.60×10^{-3}	1.2	108.55
1/8	42.0	0.45	17.94×10^{-3}	30.01×10^{-3}	1.7	23.57
3/16	42.0	0.45	15.54×10^{-3}	22.07×10^{-3}	1.4	5.35
1/4	42.0	0.45	15.54×10^{-3}	28.25×10^{-3}	1.8	4.58

¹ At full fluidization flow rate.

Table 3
Results of Experiments Using Various Hole Spacings, Hole Size
of 1/8 in.

Hole Spacing in.	Sand Depth cm	Sand Size mm	Initiation Flow Rate, Q_i ft ³ /sec/ft	Full Fluid- ization Flow Rate, Q_f ft ³ /sec/ft	$F = Q_f/Q_i$	Pressure Head in Pipe, ft ¹
1	25.4	0.15	1.17×10^{-3}	4.60×10^{-3}	3.9	3.05
2	25.4	0.15	0.90×10^{-3}	3.95×10^{-3}	4.4	3.33
3	25.4	0.15	1.09×10^{-3}	5.93×10^{-3}	5.5	4.69
4	25.4	0.15	1.07×10^{-3}	5.76×10^{-3}	5.4	6.05
1	42.0	0.15	1.80×10^{-3}	6.82×10^{-3}	3.8	3.58
2	42.0	0.15	1.57×10^{-3}	6.18×10^{-3}	3.9	5.02
3	42.0	0.15	1.86×10^{-3}	7.84×10^{-3}	4.2	6.59
4	42.0	0.15	1.82×10^{-3}	6.10×10^{-3}	3.4	6.83
1	25.4	0.45	6.07×10^{-3}	15.43×10^{-3}	2.5	4.75
2	25.4	0.45	7.73×10^{-3}	19.07×10^{-3}	2.5	11.20
3	25.4	0.45	7.77×10^{-3}	18.61×10^{-3}	2.4	1.80
4	25.4	0.45	7.77×10^{-3}	14.83×10^{-3}	1.9	23.90
1	42.0	0.45	10.24×10^{-3}	21.43×10^{-3}	2.1	6.40
2	42.0	0.45	11.05×10^{-3}	24.01×10^{-3}	2.2	17.10
3	42.0	0.45	9.60×10^{-3}	21.90×10^{-3}	2.3	28.00
4	42.0	0.45	11.65×10^{-3}	21.90×10^{-3}	1.9	42.50

¹ At full fluidization flow rate.

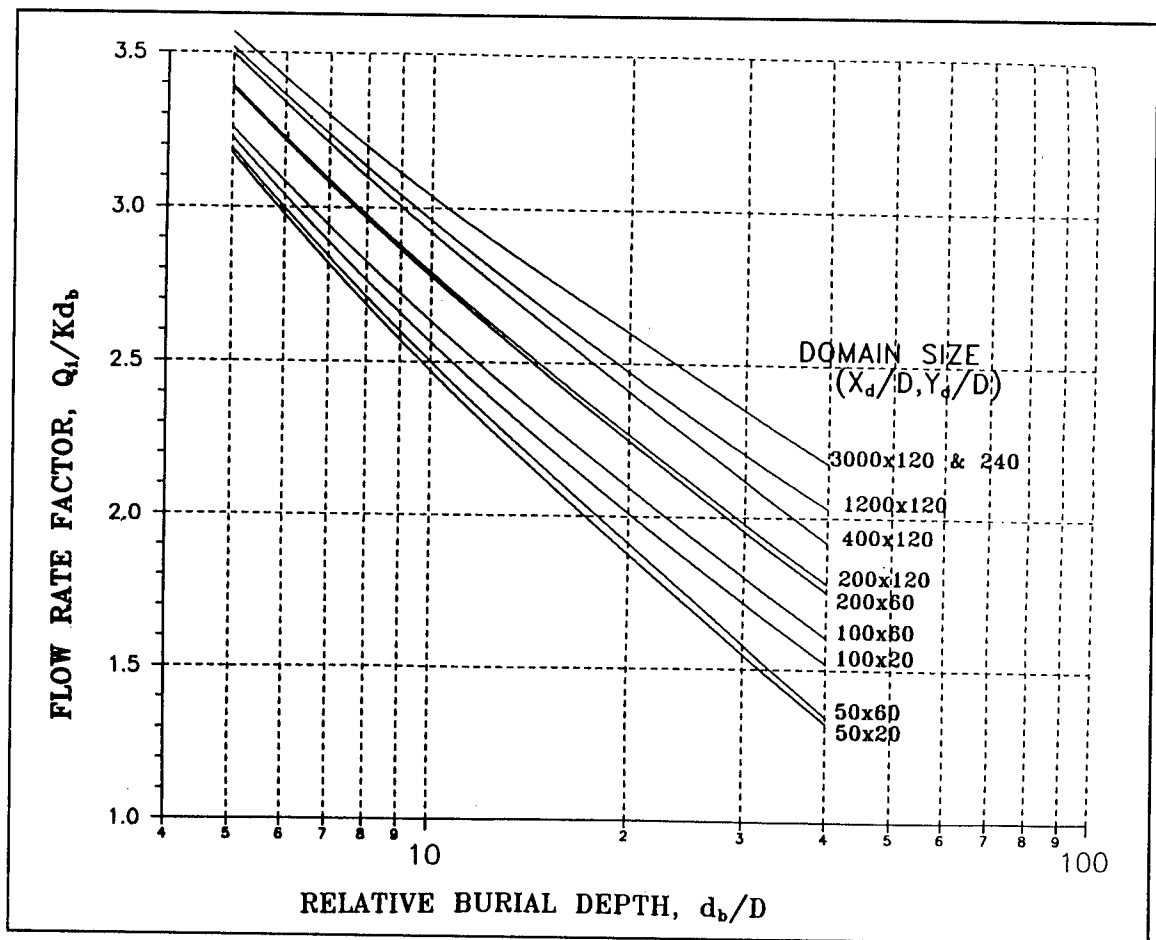

Figure 7. Chart for isotropic conditions providing required incipient flow-rate factor (Q_i/Kd_b) versus relative burial depth (d_b/D) for inspected domain sizes

locations, a K equal to 40×10^{-4} cm/sec is suggested. For other grain sizes, a soil mechanics text should be consulted, e.g., Eckert and Callender (1987).

The influence of the extent of the sediment layer on flow rate factor Q'_i/Kd_b is shown by an example. The incipient flow rate is obtained from

$$Q_i = (Q'_i/Kd_b) \times K \times d_b \times \text{pipe length} \quad (1)$$

For a 100-ft-long pipe with outside diameter $D = 1$ ft and a burial depth of 20 ft, $d_b/D = 20$. The abscissa of Figure 7 indicates that the flow rate factor, Q'_i/Kd_b , is about 1.9 for the smallest domain considered (bottom curve: 50 ft wide by 20 ft deep below pipe), and about 2.6 for the largest domain considered (top curve: virtually infinite in horizontal extent and depth). Once a geometry is determined, the flow rate factor will be determined. If the conservative value of 2.6 is used for flow rate factor for a 20-ft burial depth, then for a fine sand with $K = 0.0125$ cm/s (0.0004 ft/s), using Equation 1 the required flow rate would be:

$$Q_i = (2.6) \times 0.0004 \times 20 \times 100 = 2.08 \text{ ft}^3/\text{sec} = 0.059 \text{ m}^3/\text{sec}$$

In most applications, the burial depth d_b will be between 5 and 20 ft, a four-fold difference, and d_b will be accurately known from the design. The required flow rate at a 20-ft burial depth is between two and three times that at a 5-ft burial depth. However, Q_I is also linearly dependent on the coefficient of permeability, which can vary by orders of magnitude. Thus, the determination of K is a very important parameter in predicting the incipient fluidization flow rate. Because a higher value of K will require a higher incipient fluidization flow rate, a conservative value of K should be selected toward the higher end of that indicated by the data.

Note that the flow rate factor is only 40 percent higher for the largest domain compared to the smallest domain considered for a burial depth of 20 ft, and the difference between small and large domains is less for shallower burial depths. If only scanty data are available to assess the extent of the sand domain, it is recommended that a conservative value of flow rate factor be used as a safety factor; it is suggested that the top curve in Figure 7 should be used. When and if additional data become available, the appropriate curve in Figure 7 can be used to reduce the conservative choice.

Other factors to consider when selecting a flow rate factor include such things as three-dimensional effects near the ends of the pipe. Unless relatively impermeable sediments are encountered, the three-dimensional effects will result in a slightly higher required flow rate than predicted by the two-dimensional theory. In a limited test of the effects of debris, the larger debris particles tended to reduce the bottom width of the trench, but the required flow rate factor was relatively unaffected.

If a domain size and sand properties are selected and coarser materials are encountered at the edge of the selected domain, some additional flow will "leak" out of the fluidization zone, and Figure 7 will underpredict the required flow rate needed to create incipient fluidization. The required head will not be affected as shown by the relatively mild dependence of head on domain size as shown in Table 4.

To achieve a trench, full fluidization is essential. At initiation of fluidization, a few areas of the bed are locally fluidized, but those local areas are isolated by large areas of dense, unfluidized sand. Hence, for design purposes, a full fluidization flow rate is required. In general, the relationship between full and initial fluidization flow rates can be stated as

$$Q_F = F \times Q_I \quad (2)$$

where F is an empirical factor greater than 1.0. Tables 2 and 3 give experimental values of Q_I' and F . For the example shown above, $Q_I = 2.08 \text{ ft}^3/\text{sec}$, $F = 10$, and $Q_F = 2.08 \times 10 = 21 \text{ ft}^3/\text{sec}$.

The range of F factors is quite large. In fact, although the flow rate required to achieve initial fluidization shows fairly consistent values for a particular sand size and depth, the full fluidization flow values show much variability.

Experience has shown that achieving full fluidization is dependent on several factors that are difficult to control experimentally, including packing and uniformity of the bed and the rate of increase in flow rate. At this time, there is no recommended theoretical technique to determine the F factor.

Inspection of the data indicates: (a) the F factors are generally smaller for the coarser sand; (b) bed depth does not appear to play a role for the bed depths tested. At this time (1996), it is recommended that an F factor of at least 5 (but less than 10) be used. This will ensure full fluidization along the entire length of the pipe.

In conclusion, the determination of flow rate Q_I should be approached as follows:

- a. Determine the depth of burial of the fluidizer pipe d_b .
- b. Determine the extent of sand layer to the side of and below pipe, X_d and Y_d , respectively.
- c. Determine the coefficient of permeability of the sand K .
- d. Use Figure 7 to obtain a flow rate per unit length of pipe required to initiate fluidization Q'_I .
- e. Multiply Q'_I by factor F and pipe length to obtain the required full fluidization flow rate Q_I .

Pressure Requirements in Fluidizer Pipe

One object of the design is to have equal flow emanating from each of the fluidizer holes. This is achieved through the proper choice of fluidizer pipe size. The pressure P required to discharge the full fluidization flow rate Q_F is dependent on the hole size and hole spacing. Obviously, for a given discharge Q_F , the flow rate per unit hole Q_h depends on the number of holes. Also, for a given discharge per hole, the velocity will be relatively high for a small hole and relatively low for a large hole. The pressure or pressure head in the fluidizer pipe must supply the energy to deliver the flow rate per hole through the chosen hole size and through the sediment bed. The total head loss is the sum of the losses through the hole and through the bed. For a pre-initiation of fluidization flow rate, the head loss through the hole is small compared to head loss through the bed. At large flow rates for full fluidization, the head loss due to the hole dominates.

For one-dimensional fluidization, the head loss through the bed is approximately 1 ft per ft of bed depth d_b . In the two-dimensional laboratory tests just prior to fluidization the hydraulic gradient is approximately 1 ft per ft of bed depth over most of the sand bed above the pipe, close to the one-dimensional value. However, because of the highly concentrated flow near the

holes, significant additional head loss occurs within a few inches of the pipe. The two-dimensional numerical simulations reported by Lennon, Chang, and Weisman (1990) indicate that due to this large loss near the pipe, the average head loss from pipe to sediment surface is 2 to 3 ft per ft of bed depth. Subsequent three-dimensional simulations indicated additional head loss occurs when the actual 1/8-in. holes were simulated, resulting in head losses averaging 4 to 5 ft per foot of burial depth. Table 4 provides three-dimensional head loss for 1/8-in. holes on 2-in. centers for various parameters. Table 4 illustrates that for shallow bed depths, the required pressure head to overcome bed loss is about 5 times the bed depth d_b , and for deeper bed depths about 4 times the bed depth is required. For a burial depth of $d_b = 20$ ft, a pipe diameter of 1 ft ($d_b/D = 20$), and an assumed large domain size, Table 4 indicates that the required bed head loss $h_{max}/d_b = 4.0$, resulting in $h_{max} = 80$ ft of head needed to overcome losses in the bed for incipient fluidization. The bed loss head requirement should be added to other system losses including orifice losses through fluidizer pipe holes and pipeline head loss to get the total system loss. Although this head requirement should be checked, head requirements at full fluidization will be the overriding constraint as discussed below.

Table 4 Variation of Head Loss Divided by Depth of Burial (h_{max}/d_b) for the Simulated Conditions (1/8-in. Holes on 2-in. Centers in a 1-ft-Diameter Pipe) for Incipient Fluidization		
Burial depth d_b/D	Small domain ¹	Large domain ²
5	5.1	4.8
10	4.6	4.4
20	4.1	4.0

¹ $X_d/D = 50, Y_d/D = 20$
² $X_d/D = 1,500, Y_d/D = 120$

As the flow rate is increased beyond the initial fluidization flow rate to full fluidization, the head loss through the bed decreases but the head loss through the holes increases. As slurry is removed from the fluidized region with the flow rate held constant, the head loss through the bed decreases, while head loss through the holes remains constant. Thus, the maximum pressure in the pipe usually occurs at full fluidization, prior to slurry removal. From experimental values of pressure head at full fluidization and after slurry removal, the difference in values in pipe pressure head is approximately 2 ft of water or less for trench depths of approximately 2 ft. Thus, a pressure head drop of about 1 ft/ft of slurry depth is indicated.

For the large, full fluidization flow rate that must be achieved, the pressure in the fluidizer pipe can be calculated as that needed to deliver Q_h through each hole plus 1 ft of head per ft of trench depth. The pressure can be calculated from the equation for a submerged orifice.

$$Q_h = C_d A_h \sqrt{2g \frac{\Delta P}{\gamma}} \quad (3)$$

where

C_d = discharge coefficient

A_h = hole area

ΔP = change in pressure from inside to outside the hole

γ = specific weight of water (62.4 lb/ft³ for fresh water; 64 lb/ft³ for salt water)

g = acceleration of gravity (32.2 ft/sec²)

For a sharp-edged orifice, the discharge coefficient is approximately 0.61. However, the values of C_d from the Lehigh experiments range from 0.73 to 0.86, with an average value of 0.79.

In summary, the pressure head in the manifold or fluidizer pipe needed to achieve full fluidization should be calculated by using Equation 3 to calculate pressure drop for water exiting the pipe and then adding 1 ft/ft of trench depth (below the water/sediment boundary). The parameters in the equation are as follows:

- a. Q_h is the total full fluidization flow rate divided by the number of holes in the fluidizer pipe. The number of holes depends on hole spacing, which is discussed below.
- b. C_d is the discharge coefficient. Experimental results indicate an average value of 0.79. To be conservative, a smaller value, say 0.75, might be used.
- c. A_h is the cross-sectional area of a hole. Hole size is discussed below.
- d. $\Delta P/\gamma$ for full fluidization is calculated from Equation 3 as

$$\frac{\Delta P}{\gamma} = \frac{Q_h^2}{C_d^2 A_h^2} \frac{1}{2g} \quad (4)$$

The value of required pressure head calculated using the full fluidization flow rate should be checked against the value obtained using the initiation of fluidization flow rate Q_i . The calculation for pressure head loss through the holes used a flow rate per hole based on Q_i ($Q_h = Q_i/\#$ of holes) in Equation 3. A head loss obtained from Table 4 must be added. Finally, the larger of the two values must be used for the design.

Hole Size and Spacing

From Tables 2 and 3 it is obvious that hole size and spacing do not have a significant effect on the flow rate required for initiation of fluidization, compared to sand depth and size. For full fluidization, the effect of hole size and spacing is also not profound. The tables do show that, for a particular sand depth and size, the full fluidization flow rates vary fairly widely and unpredictably as hole size or spacing is varied.

When initial fluidization occurs, the pressure in the fluidizer drops significantly for large hole size and barely at all for the smallest hole size. This occurs because most of the head loss is caused by the hole, rather than the bed for the small hole size. As the flow is increased for the small hole size, the pressure head in the pipe is still large and a relatively large proportion of the total flow still emanates through holes within unfluidized areas. Hence, full fluidization occurs relatively efficiently. For the large hole size, full fluidization occurs less efficiently because the pressure head in the pipe is low after initial fluidization; with further increases in flow rate, there can be insufficient flow through unspouted holes to cause opening.

The discussion above is quite general and the process of evolving from initial to full fluidization is not well defined. The flow rate at which initial and full fluidization occurs also depends on the compaction and nonuniformity in the bed. Hence, the recommendations for hole size and spacing are subjective to some degree. The recommended values are hole spacings of 1 to 2 in. and hole sizes of 1/8 to 3/16 in.

Another consideration in choosing hole size and spacing is the pressure head requirement. If the hole size is very small, say 1/16 in., the pressure head required to achieve the full fluidization flow rate is large. This, in turn, will necessitate more expensive pipe materials and fittings and larger power requirements for the pump.

Although not causing as significant a rise in pressure head as small holes, the wider hole spacing also necessitates a higher pressure head. Also, the 4-in. hole spacing does not achieve as fully fluidized slurry as the closer spacings. With only one hole clogged, the resulting 8 in. between the two adjacent open holes would leave a solid unfluidized region near the pipe.

In summary, a reasonable compromise is to recommend hole sizes of 1/8 to 3/16 in. spaced 1 to 2 in. apart.

Pipe Size

The fluidizer pipe is a manifold whose function is to provide a uniform flow out of the holes. This requires that the hydraulic head remain fairly constant along the fluidizer pipe. Manifold design is treated in the literature (McNown 1953). One unique feature of the fluidizer pipe as a manifold is that energy

losses due to the holes are negligible because of the very small ratio between hole size and pipe diameter.

Miscellaneous Constraints

Several limitations and constraints of the methods and ideas discussed on fluidizer pipe design must be included for completeness. Most of the design ideas have evolved through laboratory experimentation and a rather small amount of information has been gathered through field experience. The limitations concern sediment size, depth of burial of the fluidizer pipe, length of fluidizer pipe, and slope of pipe.

All experiments and field experience thus far have been with fine to medium sand. There is no experience with either finer or coarser material.

- a. *Fine material.* As long as fine material is noncohesive, fluidization should work. However, if some cohesive materials are present there may be difficulty in achieving full fluidization and with trench formation (side slopes may not slump).
- b. *Coarse sediment.* Clearly, it takes much larger flow rates to fluidize medium sand compared to fine sand. There may be a practical limitation to sediment size such that the flow rate requirements to achieve full fluidization become uneconomically large.

For practical reasons, all experiments to date have utilized fairly shallow depths of burial of the fluidizer pipe. The installation at Anna Maria, Florida, utilized burial depths of 11 ft and worked successfully. At Oceanside, California, burial depths of up to 12 ft were successfully fluidized. The computer simulations of initiation of fluidization performed by Lennon, Chang, and Weisman (1990) show that initiation of fluidization can occur for large depths if sufficient flow is used. However, before trying to implement a design for placing fluidizer pipes at depths greater than 30 ft, it is recommended that experience be gained for burial depths in the 10- to 20-ft range and then the 20- to 30-ft range.

The two-dimensional experiments at Lehigh University used fluidizer pipe lengths of 1 ft and the three-dimensional tests used lengths of 10 to 40 ft. The Anna Maria, Florida, installation consisted of six fluidizer pipes, laid end to end, each of 100-ft length. At the Oceanside, California, bypass plant, the fluidizer pipe lengths were 150 and 200 ft. The manifold design shows that, because longer fluidizer pipes require larger flow rates, a longer pipe must have a larger diameter. Limitations on fluidizer pipe length may occur due to the following:

- a. Limitations either on the pump or pipe size available. To overcome these limitations, the required fluidizer length can be divided into shorter modules, as done in the Anna Maria project.

b. Limitation due to pipe slope. If the fluidizer pipe is placed on a 1 percent slope to provide for flow of the slurry to a jet pump, then the downstream end of the pipe may require extremely deep burial if the pipe is long. A 1,000-ft-long pipe would require 10-ft deeper burial at the end. This may have significant implications where clay or rock layers underlie the sands.

Very little data exist on the flow of slurry down a sloping pipe. The experiments at Lehigh University used fairly short pipes (10 and 40 ft) on slopes of 1 to 2 percent. At the time the experiments were performed, the feasibility of fluidization was being assessed, and no data were taken on flow velocity of the slurry in the trench, rate of trench formation, or limitations on pipe slope. These uncertainties can only be resolved by further experiments and field experience.

3 Elements of a Fluidizer System

The fluidizer system contains several components which are discussed here, including choices for design of the system components, e.g., pipe materials, pump requirements, clear water intake, etc. as well as operational problems and decisions, such as clogging and debris accumulation. These topics are not discussed in a particular order.

Pipe Materials

The choice of materials, either metal or plastic, for a fluidizer pipe has several implications. For a metal pipe, steel and iron are readily available. There are many different plastics that are used to make piping, such as high density polyethylene (HDPE) or polyvinyl chloride (PVC).

The most obvious problem with steel or iron pipe is its potential to corrode. However, it is possible to treat steel or iron to prolong its resistance to corrosion. A particular problem with corrosion of a fluidizer pipe is that the holes in the pipe can either corrode shut (tuberculation) or, by frequent flushing, enlarge with time. The problems associated with hole clogging or enlargement and solutions to the hole-clogging problems are discussed below.

The steel fluidizer pipes installed at Anna Maria, Florida (Lake LaVista Channel), were pumped every 5 to 7 months for approximately 2 years. Then, after a lapse of about 14 months, an attempt to pump water through the pipes was not successful. A piece of pipe was brought to the surface for inspection and was found to be corroded and biofouled. Most of the holes were shut by corrosion. It was felt by those operating the project that more frequent pumping would have kept the holes clean (but enlarged, perhaps) for a longer period of time.

While a steel or iron pipe with horizontally opposed holes will not self-bury, it will also not rise. However, a plastic pipe carrying clear water may be buoyant in a fluidized slurry (which can be thought of as a dense fluid). Whether a plastic pipe is buoyant in such an environment depends on the density of the plastic. Even if the plastic pipe is negatively buoyant, it may not be heavy enough to resist motion by waves when the trench is open. Hence, it is

recommended that plastic pipe fluidizers be anchored in place until more experience in this regard is gained. This can be accomplished by strapping the pipe to driven piles or screw anchors. At Oceanside, the HDPE fluidizer pipes were anchored to support piles.

Some plastics are quite resistant to abrasion while others are not. The water supply to the fluidizer will certainly carry very fine sediment and shell fragment. The high-velocity jets can enlarge the holes if the pipe material is not resistant.

At the Oceanside, California, sand bypass plant HDPE fluidizers used to assist in deploying and retrieving the jet pumps used were operated daily during the 5-day work week. After approximately 700 hr of operation over a 15-month period, the fluidizer holes at the lower ends of the fluidizer pipes showed some erosion (scalloping).

Biofouling is also a concern when choosing pipe material. As long as water is flowing through the system, there is little likelihood that marine organisms will take hold either in the hole or in the pipe. However, if the flow is intermittent, this may be a problem. Again, there is no experience to report, except that the pipe from Anna Maria did show some evidence of biofouling.

Clear Water Supply

It is essential that the fluidizer pipe be supplied with fairly clear water. Sand, debris, and organic matter (seaweed) can clog the holes in the fluidizer pipe and the pipe itself. Weisman, Collins, and Parks (1982) used a submersible pump that rested on a sandy bottom to supply a 40-ft-long fluidizer pipe on a New Jersey beach face. At times, wind blew seaweed into the shore and breaking waves created high turbidity. Clogging problems ensued. Upon inspection, little bits of algae were plugged into almost every hole and sand was accumulating in the pipe.

To ensure a relatively clear water supply, the intake to the supply pump should be protected by screening and other measures. The intake should not be located in or near breaking waves or too close to the bottom. Sufficiently fine screening should be used to eliminate floating organic matter and debris from the intake. Richardson and McNair (1981) discuss a similar problem of water supply for jet pumps.

Pump Requirements, Clogging, and Hole Wear

Based on the discussion of flow rate and pressure requirements in Chapter 2, a pump can be selected. The total head requirement must include the head losses in the delivery line to the fluidizer, the head required to obtain a flow rate of Q_h per hole, and the head loss in the slurry.

With a flow rate and total head, a pump selection can proceed. However, there are several contingencies that must be understood that affect the demand on the pump.

- a. If holes enlarge due to corrosion and/or abrasion, the head requirement on the pump will decrease and the flow rate will increase.
- b. Conversely, if corrosion causes holes to close up (tuberculation), the head increases and flow rate will decrease, perhaps jeopardizing the ability to fully fluidize the overlying bed.
- c. If some holes clog with debris or by tuberculation, the pressure in the fluidizer pipe will increase. The pump, pushing against a higher head, will deliver a smaller total flow rate. However, the smaller total flow rate divided by the number of remaining open holes may yield a flow rate per open hole that is larger than the flow rate per hole when all holes are open. This phenomenon may help to overcome some clogging by blowing out some holes or eroding partial blockages.

The consequences of diminishing or enlarging hole size can be assessed by inspecting Table 2. In general, as hole size increases for a given spacing, the flow rate required for full fluidization increases. However, the experimental evidence shows several anomalies. Still, if a conservative value for the design full fluidization flow rate is chosen, a slight increase in hole size over time should not cause a difficulty.

The consequences of some holes clogging can be assessed to some degree by looking at the experimental data in Table 3 for fluidizer pipes with various hole spacings. For instance, if the designed pipe has hole spacings of 1 in. and every other hole clogs, the average spacing will be 2 in. Table 3 indicates that the flow rate requirement for full fluidization changes very little for various hole spacings, but the pressure head requirement to deliver that flow increases, because the flow rate per hole must increase (Q_h must double when half the holes clog). It is questionable whether a single pump chosen for the design condition can achieve full fluidization if a significant proportion of holes are clogged. A booster pump may be necessary in this situation.

The discussion above assumes that the clogged holes are spaced out along the fluidizer pipe. If several holes in a row get clogged, an area of unfluidized sand will remain which can interfere with trench formation. The unfluidized region acts like a dam and prevents transport of slurry along a sloping pipe.

Fluidizer designers should expect to have sand enter the fluidizer that could eventually clog the fluidizer. The designer has two options to combat this problem. First, the designer can attempt to prevent as much sand as possible from entering the fluidizer. This will involve keeping the holes as small as possible, operating the fluidizer as much as is practical, and not allowing excessive sand to accumulate over the fluidizer. While it is very likely

uneconomical to operate the fluidizer at the pressure and volume required for fluidization for long periods, it may be possible to have a minimal amount of flow a considerable amount of the time. A storage tank that is filled at the end of the operating day and allowed to gravity flow through the fluidizer overnight is a possibility.

The other option to combat clogging problems is to allow for sand that enters the fluidizer to be easily removed. While options to prevent sand from entering should be considered, options to remove sand trapped in the fluidizer should be included in all designs. Experience with the fluidizers used on the Oceanside sand bypass system suggests several options. The fluidizer should be designed so that the lower end of the fluidizer can be exposed without difficulty. Blind flanges should be provided at the lower end of the fluidizer pipe to allow divers to remove the flange and insert a jetting device to remove sand. Another option is to install a manually operated valve, about 1 to 2 in. in diameter, in the lower end of the fluidizer that divers could operate to flush sand from the system. Finally, one-way rubber duckbill-type valves could be placed on the bottom along the lower ends of the fluidizer to help flush sand during normal operations. Planned Phase III modifications to the Oceanside sand bypass plant include 1/2-in. diameter rubber duckbill-type valves spaced every 10 to 20 ft along the lower 50 ft of the fluidizer. Additional flow through these valves should be accounted for during fluidizer design.

Debris Accumulation in Trench

The layer of sand above a fluidizer pipe may contain cobbles, shells, and other debris. In the experiment reported by Weisman, Collins, and Parks (1982) at Corsons Inlet, New Jersey, large shells were encountered in the beach face sediments; however, the shells seemed to offer no impediments to the fluidization and trench formation processes. Concerns were also expressed when the Oceanside sand bypassing system was being designed concerning the presence of cobbles in the sand matrix. However, experience at Oceanside indicated debris was not a significant problem.

An experiment was performed at Lehigh University to assess the effect of cobbles in the sand matrix.

- a. To start, the fluidizer pipe was buried with sand and randomly placed cobbles, whose sizes are approximately 1/2 in. x 1 in. x 2 in. The initiation and full fluidization flow rates were quite similar to those with no cobbles in the sand bed. At full fluidization, the cobbles in the fluidized region settled to the bottom of the fluidized zone, covering the pipe.
- b. After full fluidization, the flow rate was reduced to zero and the sand bed was repacked over the cobbles. During this process, sand filled the pores between the cobbles. The flow rate was increased to initial and, then, full fluidization. Even with the layer of cobbles over the pipe, the flow rate to

achieve full fluidization was approximately the same as with no cobbles present.

- c. While fully fluidized, the slurry was siphoned off, leaving a trench. However, the presence of the cobbles did affect the final trench geometry, as shown in Figure 8. The obvious effect of the cobbles is to eliminate the scour zone around the fluidizer pipe. The sides slope at the angle of repose down to the top of the cobble layer. Thus, the effect of debris is to eliminate the bottom width, which in turn reduces the trench top width somewhat.

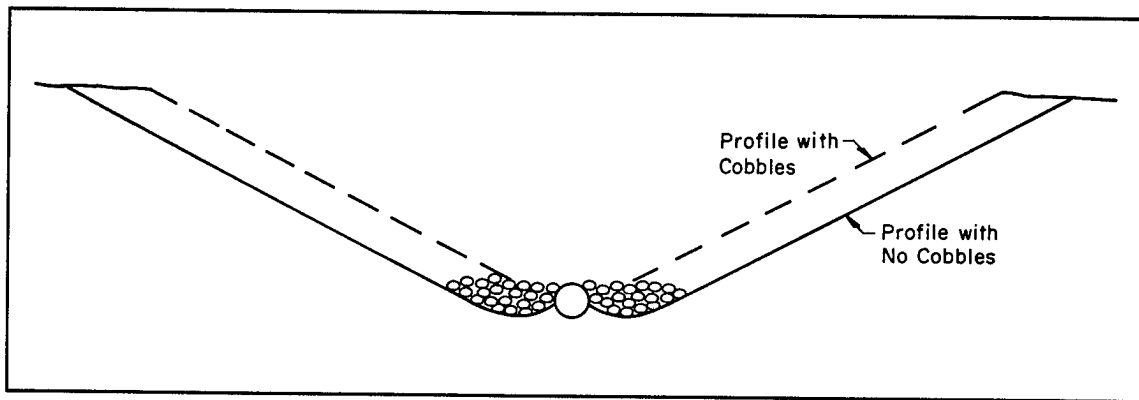

Figure 8. Experimental trench geometry with and without cobbles present in sand

Based on the experiment described above, two items should be considered by a designer.

- a. If cobbles or shells are present in the environment, some thought must be given to a decreased trench top width as those larger sediments accumulate over the pipe.
- b. Some method should be considered to remove the cobbles or shells at some point. It is conceivable that, eventually, much of the trench cross section could fill with coarse material. A plan to remove the coarse material should be part of the fluidizer design.

Operating Time

The timing of operation of the fluidization system involves two factors:

- a. Start-up criteria.
- b. Duration of operation.

To answer these questions, the following paragraph contains information on the time required for trench formation.

In the two-dimensional experiments conducted at Lehigh University, the trench forms quickly in response to the removal of the slurry by siphoning. The slumping of the side walls progresses at a pace equal to the rate of slurry removal. In the three-dimensional laboratory experiments and in the Corsons Inlet beachface test, the slurry was removed by pumping with a slurry pump and by gravity flow down a pipe placed on a 1-2 percent slope. When the slurry pump was used, the slurry migrated to the pump and the trench formed at a similar rate. Figure 9 shows a sketch of the experiments performed with sloping pipes. When fully fluidized, a trench is formed and the sediment begins to flow to the lower end of the pipe, forming a sand "dam" at the lower end. A continuous flow of slurry occurs if the dam is removed; this simulates the flow of slurry into a crater. The slurry flows along the pipe at an average velocity of approximately 0.5 to 1.0 ft/sec. Thus, the 10-ft long trench in the laboratory formed in a few minutes; at Corsons Inlet, it took approximately 5 to 10 minutes for the trench to form. In summary, the rate of trench formation is limited by either the rate of slurry removal by a pump placed in the trench or by the rate of migration of slurry to a crater. In the latter case, the rate of supply of sediment is probably greater than the capacity of a jet pump.

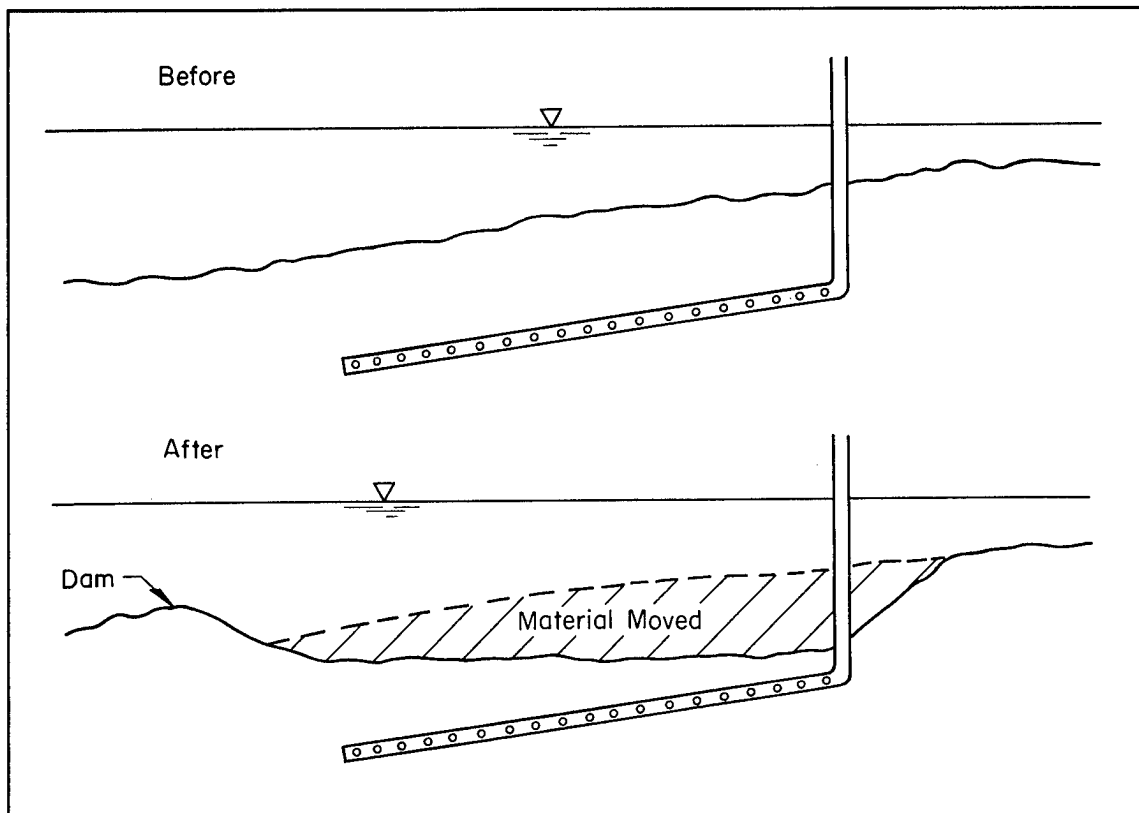

Figure 9. Formation of a sand "dam" near the downstream end of the fluidization pipe when slurry was not removed in an experiment on a beach face

The start-up criteria depend on the application. For channel maintenance, the system should be operated whenever shoaling begins to infringe on navigation requirements. For sand bypassing, a trench must be maintained to act as a sediment trap. However, for bypassing, the trench can be almost full before it allows sand to be carried across. This brings up a problem concerning the monitoring of the trench. A visual observation may be possible and sufficient for some applications, but, for others, a remote sensing will be required. Conventional depth-sounding techniques are probably the most logical method of determining the amount of sand over the fluidizer pipe in a channel. A precise positioning system, or marked buoys and/or range markers may be needed to determine exact location of the trench. Surf zone applications will likely present more difficult problems for determining sand elevations above the fluidizer pipe. A sonar altimeter is a potential alternative to conventional boat-mounted depth sounders which are difficult to operate in the surf zone. The sonar altimeter is a self-contained depth sounder mounted in a pressure housing. Attaching such a device to a pipe located at the edge of a trench could provide sand elevation below the instrument. Output from the instrument can be cabled to a shore station.

The duration of operation must last until slurry has been removed and the trench has formed.

- a. When the slurry removal mechanism is a slurry or jet pump, the constraint is the slurry pumping rate. For instance, a 100-ft-long fluidizer pipe, 10 ft beneath the sand surface contains approximately 700 yd³ of sand. A typical jet pump can handle approximately 200 yd³/hr. Thus, it may take 3.5 hr for the jet pump to dispose of the supply from the fluidizer. At Oceanside, the capacity of the fluidizer trench was approximately 600 to 800 yd³, while jet pump capacity was about 100 yd³/hr. Because the same supply pump operated both the fluidizer and jet pump, bypassing at Oceanside required several fluidization sequences each day. See Appendix B for additional details on the Oceanside bypassing system.
- b. When the slurry-removal mechanism is gravity flow, the trench-making process is relatively faster than the limitations imposed by a jet pump. At this time there is not very much information beyond that reported above for the Lehigh experimental work.

The installation at Anna Maria, Florida, was comprised of six modular fluidizer pipes, each with its own standpipe. With only one pump, the six modules were pumped in sequence, starting at the ocean end. The sequence was repeated several times.

Installation of Fluidizer Pipe

The most direct technique of installing a fluidizer pipe is to predredge an area, place the pipe, and operate the system after shoaling has occurred. This

method has been used for the Oceanside project, with the fluidizer pipes secured to vertical support piles.

An innovative technique was used by StaDeep Systems, Inc. to install a fluidizer system at Lake LaVista Channel. The system consisted of six 100-ft modules in series, creating a 600-ft-long system. As shown in Figure 10, each module was comprised of a 100-ft-long fluidizer and a feed pipe. The modules were arranged so that two feed pipes were close together, so the barge and pump could make three setups to pump six modules.

Each module was placed using a self-burial method. As shown in Figure 10, the burial depths ranged from a few to 11 ft at the highest point along the bar. Each pipe was set with holes pointing straight up and down, with the upward-pointing holes taped temporarily. A flexible hose and pivot connected the feed pipe to the pump. The pipe was lowered in a controlled manner by letting it down by winches from a barge. Once the pipe reached its proper depth and location, the tape was removed from the holes and the fluidizer and feed pipe were rotated 90 deg, leaving the fluidizer with horizontally opposed holes and the feed pipe standing vertically. Although somewhat successful, the control on the final location of the modules was not highly accurate.

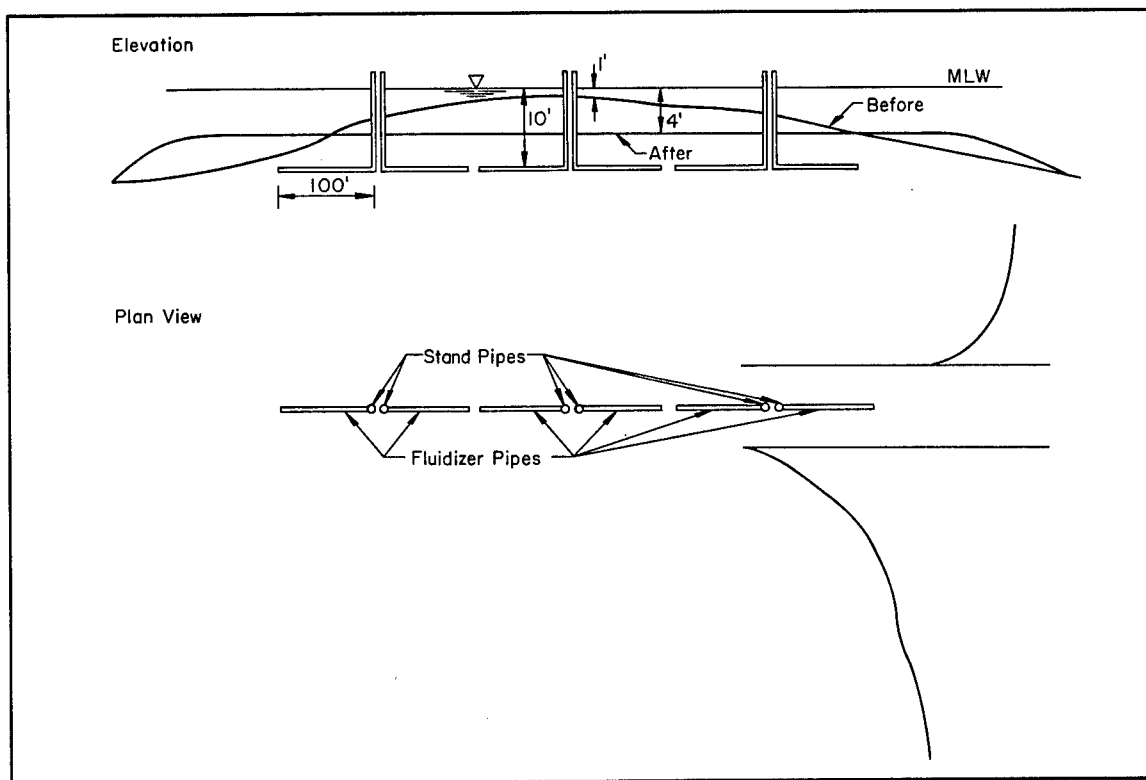

Figure 10. Elevation and plan views of modular fluidizer pipe and stand pipe configuration used at Lake LaVista Channel, Anna Maria, Florida

4 Summary of Design Procedure

The design of most coastal engineering projects, including design of fluidization systems, should begin with an office investigation of available coastal process data. Often the office investigation will determine that not all the coastal process data required are available, requiring additional data to be collected in the field (SPM 1984). The first step in the office phase is to review existing data and begin the design process. Parameters that can be estimated without a field program should be estimated, with a field study (if necessary) providing the actual data required (see Chapter 1). The field data should be reviewed, final parameter values selected, and the design should be implemented. At the conclusion of the data acquisition phase information should include:

- a. Estimates of direction and volume of littoral drift.
- b. Available information on the sediment type, size, and distribution.
- c. Historical records of morphology, shoreline location.
- d. A historical survey that may help identify the geomorphology of the site, thereby providing insight into the nature and nonhomogeneity of the materials encountered. Information on coastal structures and their impact is also required.
- e. Seasonable variations.

The next step is to determine design conditions by considering how the fluidizer system will interface with the overall system; depending on the location of jet pumps or other equipment, identify constraints on location of fluidizer system (see Chapter 1 for sand bypassing and channel maintenance). Once the location has been chosen, the design geometry for the trench is selected (see Chapter 2, Figure 5) including slope, location (length), depth (elevation), and width of channel.

Select the design parameters of the fluidization system using the following plan:

- a. Consider several designs for various burial depths, including multiple parallel pipes if needed to achieve the design width; overtrenching may be required to achieve the design geometry.
- b. Select design from trial designs.
- c. Determine pump location and clear water intake.
- d. Estimate pipe diameter D ; choose 1 ft if uncertain. Determine incipient flow rate factor Q'_I/Kd_b , from Figure 7. Required data:

D, d_b, K , estimated sediment domain size (see Chapter 2).
- e. Determine incipient fluidization flow rate from Equation 1 (see example with $Q_I = 2.1 \text{ ft}^3/\text{sec}$).
- f. Select F factor after reviewing Tables 2 and 3 and paragraphs explaining Equation 2; $F = 5$ to 10 is recommended at this time, with 10 being the more conservative value.
- g. Determine full fluidization flow rate by Equation 2:

$Q_F = F \times Q_I$ (see example, $Q_F = 21 \text{ ft}^3/\text{sec}$).
- h. Select hole geometry (size and spacing) in the fluidizer pipe (see recommendations in Chapter 2). Likely selection is horizontally opposed 1/8-in. holes at 2-in. spacing.
- i. Determine the pressure head requirements in the fluidization pipe which includes the pressure head loss through the orifice plus a loss through the fluidized bed at full fluidization (see Chapter 2).
- j. Select fluidizer pipe diameter D based on procedure in Appendix A. Repeat steps *b* to *g* with new D ; repeat if necessary.
- k. Select fluidizer pipe material, etc.
- l. Decide on methods to mitigate fluidizer pipe clogging.

Next, the installation technique must be chosen (Chapter 3). Although the frequency of operation criteria for operation can be estimated, it will actually be determined during operation, being "triggered" by accumulated depth of sediment in the trench. The duration of operation will be determined by how long it takes to achieve the refluidized trench design bottom elevation; this will probably be constrained by how fast the jet pump can remove the slurry for sand bypassing operations; hence, the two systems should be sized/designed together. It is likely that the fluidizer pipe will operate more intermittently than the jet pump.

Example 1: Navigable Channel Maintenance

This hypothetical example is similar to the prototype at the Anna Maria, Florida, project in that fluidizer pipes are designed to maintain a channel through an ebb tidal bar at an inlet to a marina. The layout of the existing physical features is sketched in Figure 11a, and cross section AA' along the centerline of the inlet is shown in Figure 11b. It is also assumed here that sufficient information exists concerning the coastal processes summarized previously in Chapter 3:

a. Direction and volume of littoral drift:

(1) Direction is assumed dominant from the north.

(2) Volume of net littoral drift is assumed to be 50,000 yd³/year.

b. Sediment is well-sorted quartz sand with some shell fragments and the particle size distribution is characterized by:

$$d_{10} = 0.18 \text{ mm}$$

$$d_{50} = 0.20 \text{ mm}$$

$$d_{90} = 0.25 \text{ mm}$$

The submerged angle of repose is 32 deg (1V:1.60H), and will be the angle of the side slopes.

c. For this example, it is assumed that the shoreline and bar have been relatively stable for many years.

d. A survey and coring study shows that the sand is underlain by a clayey layer at a depth of 43 ft below the water surface (51 ft below datum). The jetties are rubble-mound structures.

e. Although the shape of the bar changes in response to storms, it changes little from season to season.

The design calls for creation of a channel whose dimensions are shown in Figure 12. The channel must be 30 ft wide and the depth must be at least 8 ft below MLW. Please refer to EM 1110-2-1615 for details on navigation channel requirements. The 8-ft depth used here exceeds the 6-ft depth suggested in the manual. One design option, Figure 12, shows that a fluidization pipe located at a depth of 17.5 ft below MLW can provide a trench that satisfies the requirements stated above. Note the "sharp" corners at the intersection of the trench sides and the original sand surface; these corners will most likely disappear due to wave action, currents, or propwash.

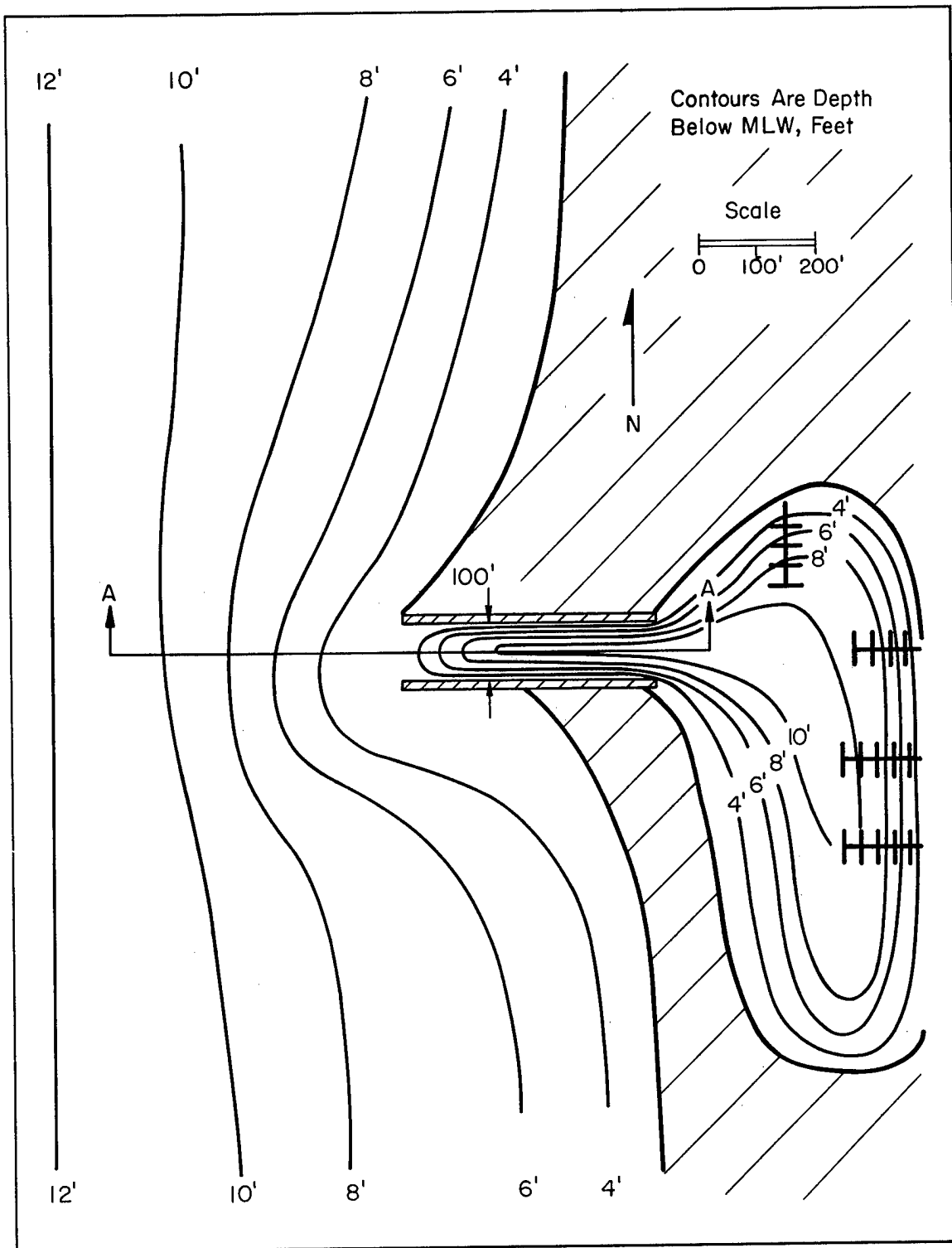

Figure 11a. Hypothetical site location for Example 1, showing inlet, jetties, shoreline, and depth contours

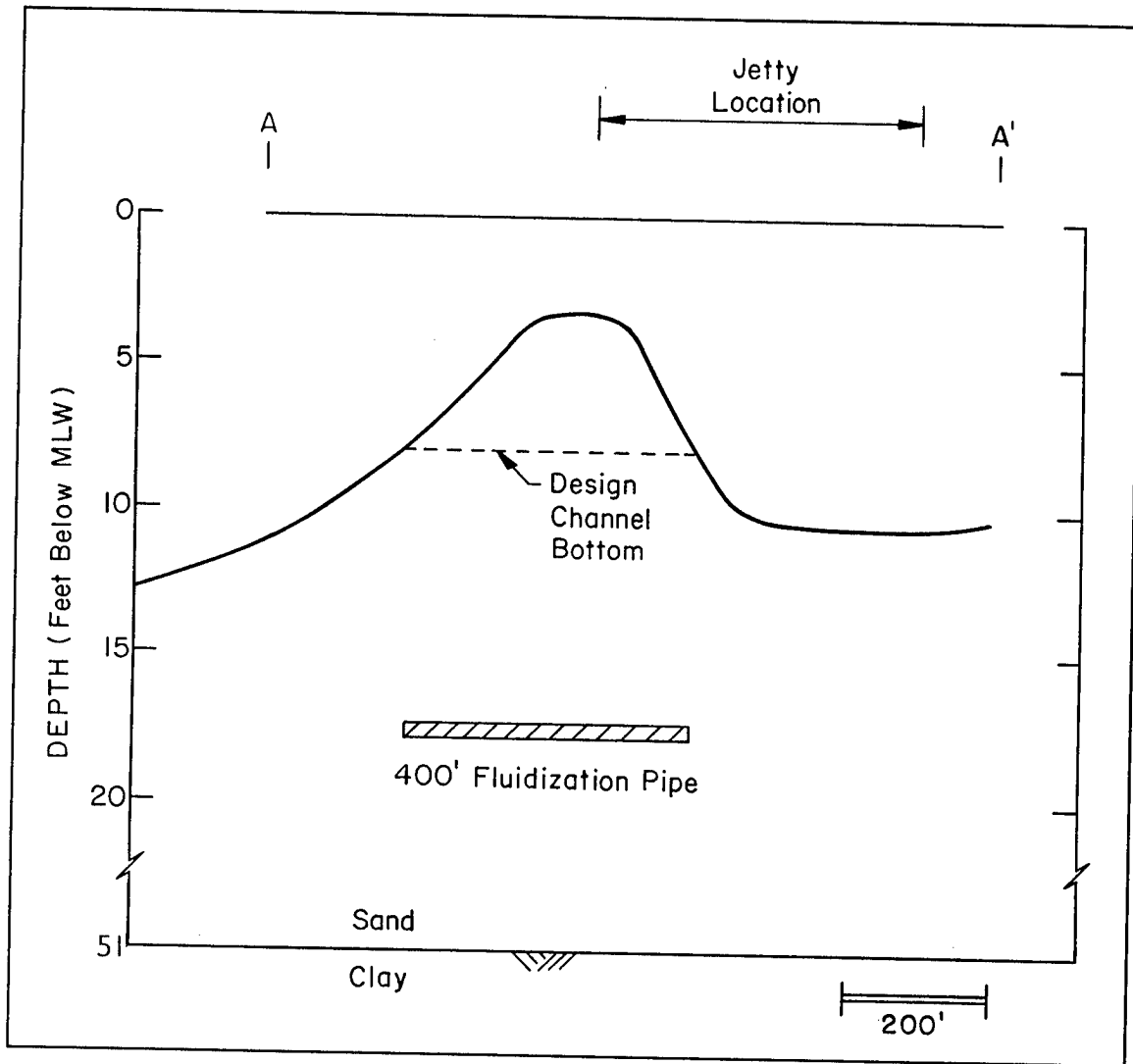

Figure 11b. Cross section AA' showing location of fluidizer pipe and initial and final channel bottom for Example 1

From Figure 12, the trench caused by fluidization is perhaps close enough to the jetties to threaten their stability. For this example, it is assumed that the jetties will be stable with one fluidization pipe at a depth of 17.5 ft. However, the following points should be noted:

- a. The jetty side slopes in Figure 12 are assumed to be 1V:2.5H. If the jetty side slopes were 1V:3H, the system as shown would not be possible because the base of the jetties would extend into the required fluidization zone. The fluidized trench sides will be at the submerged angle of repose of 32 deg (1V:1.60H).

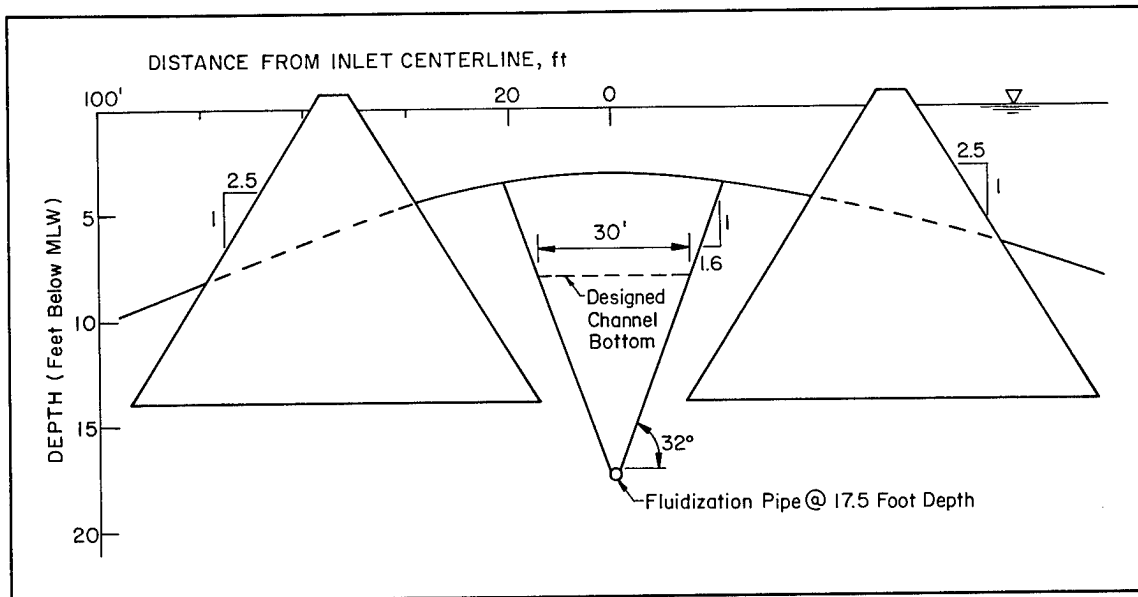

Figure 12. Cross-section view perpendicular to and at the end of the inlet jetties showing fluidizer pipe, trench location, and initial and final channel bottom for Example 1

- b. If the navigation requirement were for a wider channel a single pipe must be placed at a deeper location than the 17.5 ft shown in Figure 12. This would likewise jeopardize the stability of the jetties. Also, a deeper location for the fluidizer may be precluded by the clay layer 43 ft below the top of the sand (though very unlikely in this case).

An alternative design option that would not threaten the jetty stability is to design a system with parallel pipes buried at a shallower depth (13 ft) as shown in Figure 13. By having parallel fluidizers, the depth of the pipes can be less than that of a single pipe to achieve the same navigation requirements.

The required length of fluidizer pipe is a function of the slurry removal mechanism chosen as part of the design.

- a. *Alternative A.* From Figure 11b, the distance across the bar between 8-ft-depth contours is approximately 400 ft. If the slurry removal mechanism is a pump, then the fluidizer pipe needs to be only 400 ft long. Given the eroded condition of the downdrift beach, the pumped slurry can be used as nourishment. This sand bypassing operation uses the navigable channel itself as a sediment trap, rather than trapping sediment updrift of the inlet mouth.
- b. *Alternative B.* At Anna Maria, Florida, a density current approach was used for slurry removal. Figure 11b is redrawn as Figure 14 to help understand the continuity of sediment problem required to choose the proper length of fluidizer. Once fluidized, the slurry will seek a horizontal plane; the top or hump in the bar will flow to lower elevations while tidal

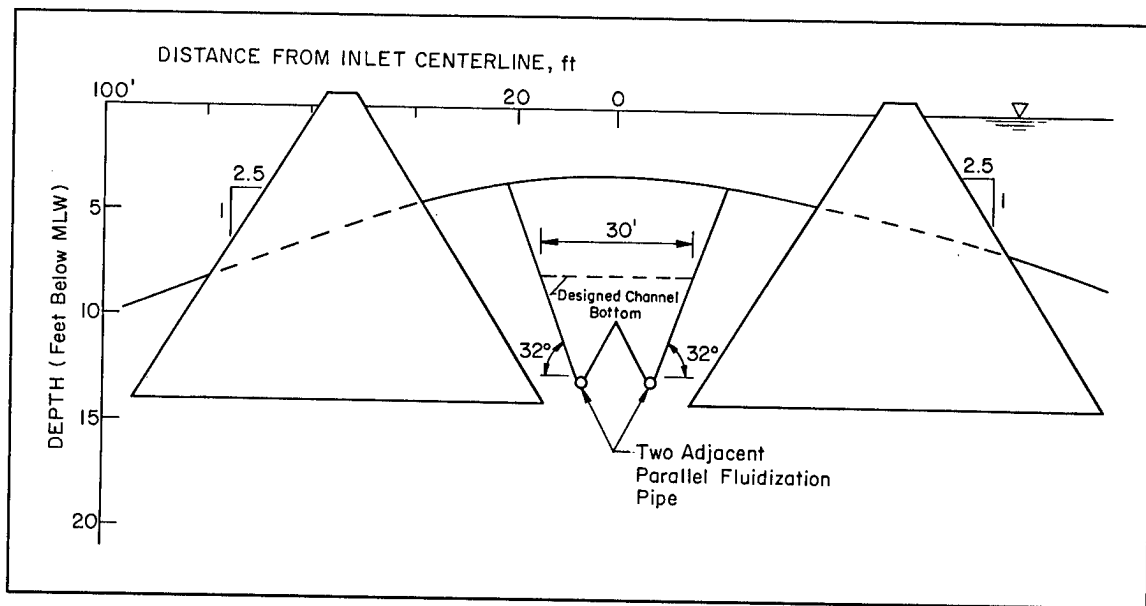

Figure 13. Cross-section view of alternative configuration of two parallel fluidizer pipes for Example 1

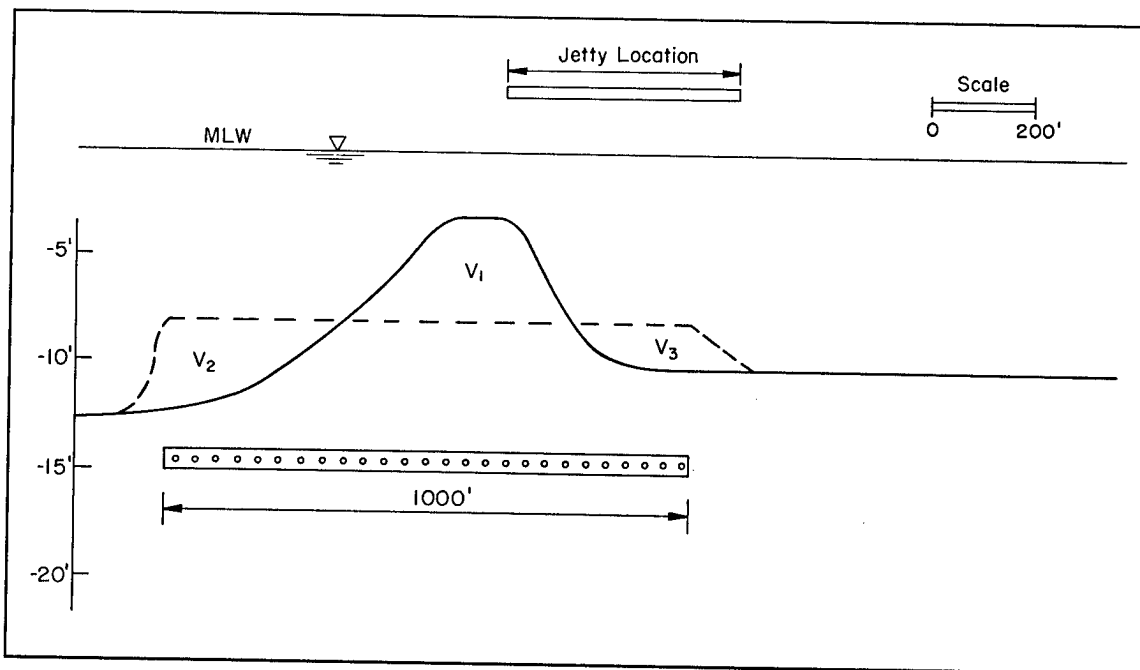

Figure 14. Cross-section view of alternative fluidizer configuration for Example 1; a longer pipeline is used than the base case shown in Figure 11b

currents and wave action help in this redistribution. Figure 14 shows that a fluidizer of length 1,000 ft is required to bring the top of the bar down to the 8-ft-depth level. This 1,000 ft of fluidizer need not be one long pipe which would require a very large pump. Rather, the 1,000 ft can be

divided into modules of shorter lengths, e.g. each 200 to 400 ft. Note from Figure 14 that some sand will flow back into the channel between the jetties and into the boat basin, but it should not raise the bed above the 8-ft depth. At Anna Maria, the bar was relatively small and six fluidizer modules, each 100 ft in length, were employed. The modules were pumped in sequence starting with the module at the ocean end and progressing toward the inlet. Also, there was no compelling motivation to nourish the downdrift beach. However in this example, even if nourishment is not required, it will probably be more economical to use Alternative A with a 400-ft fluidizer and jet pump, rather than B with a 1,000-ft pipe or series of pipes. Cost estimates of both alternatives should be considered.

This example continues with Alternative A, 400 ft of fluidizer and trench formation caused by pumping slurry from the trench. Rather than using modules that need to be pumped individually, one continuous 400-ft pipe is used here, supplied by a feed pipe halfway along its length.

All equipment, including (a) the pump and clear water intake for the fluidizer and (b) the pump and clear water intake for a jet pump, can be located either on the jetty or back on the shore. The clear water intake(s) can be located in the channel. A submersible slurry pump could be used instead of a jet pump, though most submersible pumps cannot be buried. See Clausner et al. (1994) for additional information on application of a jet pump and submersible pumps for sand bypassing. All discharge lines and other auxiliary equipment must be located on the site.

The required full fluidization flow rate must be chosen. The factors that are required to use Figure 7 to estimate the full fluidization flow rate include the following:

X_d = horizontal domain of sand (assumed virtually infinite)

Depth of sand layer = 43 ft

D = pipe diameter = assume 1 ft initially

d_b = burial depth = use 18 ft

Y_d = depth of sand below pipe = $43 - 18 = 25$ ft

The domain size in this example ($X_d/D = \infty$, $Y_d/D = 25$, $d_b/D = 18$) does not correspond to any of the curves in Figure 7. A large horizontal domain size tends to give a large flow rate factor while the small vertical domain size yields a relatively small flow rate factor. A conservative (but not the most conservative) choice of $Q' / Kd_b = 2.5$ is used here which corresponds to a position in the top-middle of the curve in Figure 7. Although a value of 2.4 or even 2.3 may be more appropriate, a value of 2.5 will lead to a slightly higher (more conservative) flow rate by 5 to 10 percent. For the sand sizes of the example, a permeability K

of 0.0004 ft³/sec is used. Using consistent units in the equation $Q'_i/Kd_b = 2.5$, the incipient fluidization flow rate per unit length of pipe Q'_i is 0.018 ft³/sec/ft (2.5 x 18 x 0.0004). Using an F factor of 5, a full fluidization flow rate per unit length of pipe of 0.09 ft³/sec/ft (see Chapter 2) is calculated by multiplying 5 and 0.018 ft³/sec ft. A 400-ft-long fluidizer requires a total flow rate of 36 ft³/sec (multiply 0.09 and 400).

A pipe with a center feed is chosen; 18 ft³/sec will flow in each direction from the center of the fluidizer. The feed pipe diameter must be chosen to minimize head losses to the fluidizer. The fluidizer diameter is chosen using the procedure outlined in Appendix A to maintain a fairly constant hydraulic head over the length of the fluidizer. See Appendix A for the calculations for this example. A pipe size of 12 in. minimizes changes in pressure along the horizontal fluidizer. If this diameter differs slightly from 1 ft, the calculations presented previously for flow rate would change very little.

The horizontally opposed holes should be spaced 1 to 2 in. apart. For the selected flow rate, the 2-in. spacing will yield a velocity through each hole twice as large as that for a 1-in. spacing. At the current state of experience with fluidization systems, it seems logical to assume that hole-clogging problems will be minimized if large velocities are maintained through the holes. As mentioned previously, high velocities require higher pipe pressures, which requires a more robust pump. The hole size selected here is 1/8-in. diameter. As mentioned previously, a smaller hole size will require excessive pressures while a large hole size may result in movement of sand into the pipe when the pump is off.

For holes spaced 1.5 in. apart, the 400-ft-long pipe has 6,400 holes. For a total flow rate of 36 ft³/sec, the flow rate per hole Q_h is (36/6,400) 0.005625 ft³/sec. The area of each 1/8-in. diameter hole is 8.52×10^{-5} ft². Using the continuity equation $Q_h = V_h A_h$ gives the velocity of flow through each hole:

$$V_h = \frac{Q_h}{A_h} = \frac{0.005625}{8.52 \times 10^{-5}} = 66.0 \text{ ft/sec}$$

Using Equation 4, the change in pressure head from inside to outside the fluidizer pipe is calculated:

$$\frac{\Delta p}{\gamma} = \frac{Q_h^2}{C_d^2 A_h^2 2g}$$

where

$$Q_h = 0.0056 \text{ ft}^3/\text{sec}$$

$$C_d = 0.79$$

$$A_h = 8.52 \times 10^{-5} \text{ ft}^2$$

$$g = 32.2 \text{ ft/sec}^2$$

The resulting required pressure head is $\Delta p/\gamma = 109 \text{ ft}$.

Approximately 18 ft of head must be added to account for the head loss through the fully fluidized bed. Thus, the pressure head required in the fluidizer pipe is 127 ft (see Chapter 2). The required head delivered by the pump must also take into consideration head losses, both pipe friction and minor losses, between the clear water intake and the fluidizer.

The volume of the trench created by the fluidizer is calculated in an approximate fashion because the shape of the bar over the pipe is irregular and changes in shape in response to wave climate and direction. The pattern of shoaling is also difficult to predict. Since the design requires a depth of 8 ft below MLW, the trench volume is calculated between the pipe and 8 ft below MLW. By assuming a triangular shape for the trench with dimensions 10 ft deep and 32 ft across the top (using a 32-deg angle of repose), the cross-sectional area of the trench is $0.5 \times 10 \times 32$, or 160 ft^2 . Multiplying by the pipe length, 400 ft, gives a trench volume of $6.4 \times 10^4 \text{ ft}^3$ or $2,370 \text{ yd}^3$.

- a. For a littoral drift of $50,000 \text{ yd}^3/\text{year}$ and assuming that the trench can capture all the littoral drift, an empty trench will fill in 17.3 days on average. Thus, if the rate of drift is uniform in time (which is unlikely), the system should be operated about twice a month. Obviously, storms will fill the trench and the system should operate immediately after storms. During mild weather, the system should operate when the trench is 1/4 or 1/2 full to avoid being overwhelmed during a storm. Information should be obtained concerning seasonal variations in littoral drift and the impact of typical storms.
- b. Information on jet pumps indicates that their capacities can easily exceed $200 \text{ yd}^3/\text{hr}$. Slurry pumps are available with higher capacities. For the total volume of $2,370 \text{ yd}^3$, it will take about 12 hr of operation to clear the trench at $200 \text{ yd}^3/\text{hr}$.

There are miscellaneous factors that must be considered such as the fluidizer pipe material, slurry outfall location, fluidizer pipe installation technique, pipe anchoring method, corrosion protection, etc.

Example 2: Sand Bypassing

This example of sand bypassing is based on the configuration of Santa Barbara Harbor, California. Selection of the Santa Barbara site for this example does not suggest that a fixed bypass system should be used for the site. It was selected as a site with the potential for a fixed plant sand bypass system and provided an example with "real numbers" on which to show the design concepts. More detailed coastal process information would be needed for final design of a fixed plant bypass system using jet pumps and fluidizers. Also, additional

experience with fluidizers will allow much more realistic estimates of fluidizer performance. This would make cost/benefit calculations more reliable.

The data for the example are taken from the U.S. Army Corps of Engineers, Los Angeles District, Santa Barbara Harbor Draft Feasibility Study (1990). Layout of the harbor is shown in Figure 15. Of particular interest is the sandbar that forms from the tip of the west breakwater. The dominant easterly littoral drift has the potential to be intercepted by fluidizer trenches before shoaling the navigation channel. The intercepted sand can be pumped across the harbor to some point near East Beach.

The data of particular interest concern volumes and frequency of littoral drift. The Corps Feasibility Study quotes longshore transport rate estimates from several sources. These estimates range from 270,000 to 377,000 yd³/year. Figure 16 shows a sediment budget for the harbor indicating a rate of 329,900 yd³/year. Based on this value, the average daily rate is 900 yd³/day, but, during the winter storm period of November through March, the rate may be as high as 4,600 yd³/day. It is assumed here that the sediment is uniformly graded with $d_{50} = 0.28$ mm.

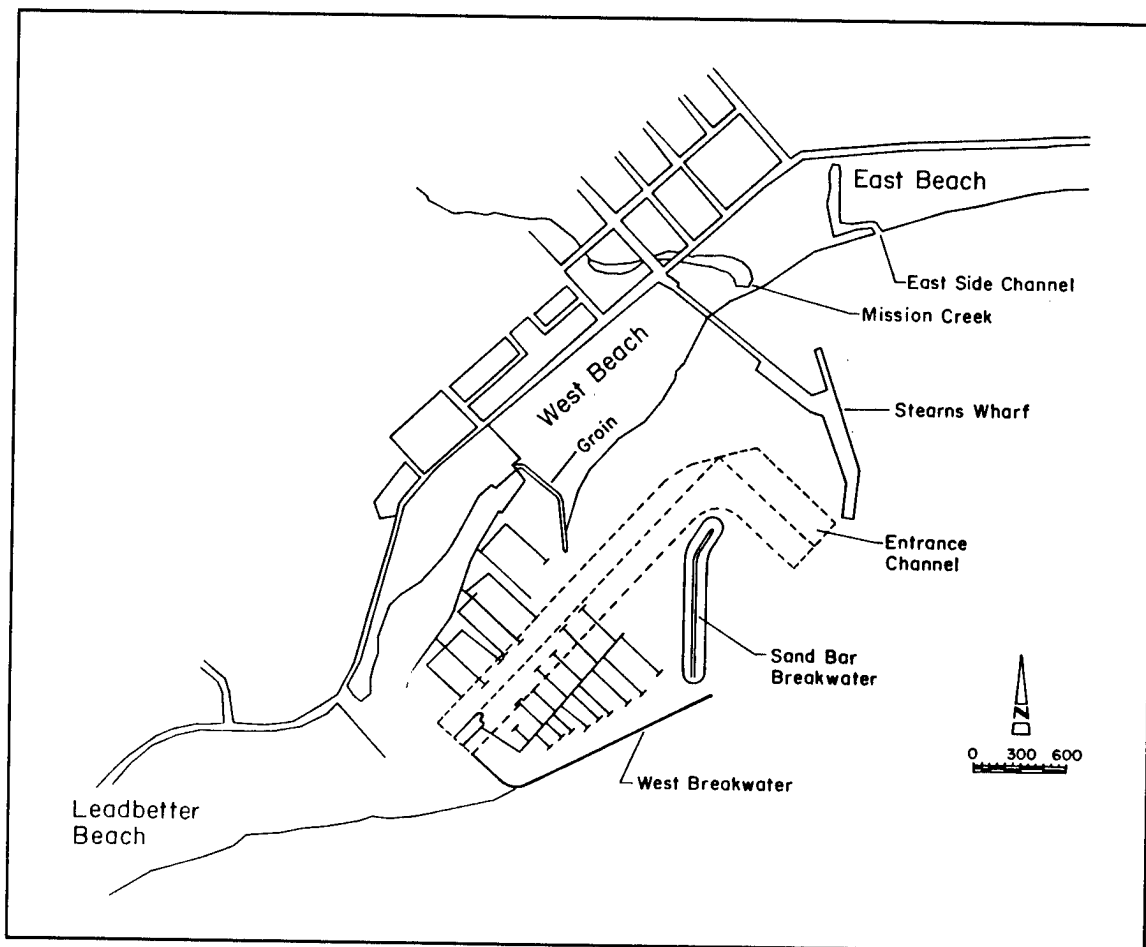

Figure 15. Sand bypassing site location, Santa Barbara Harbor, used for Example 2

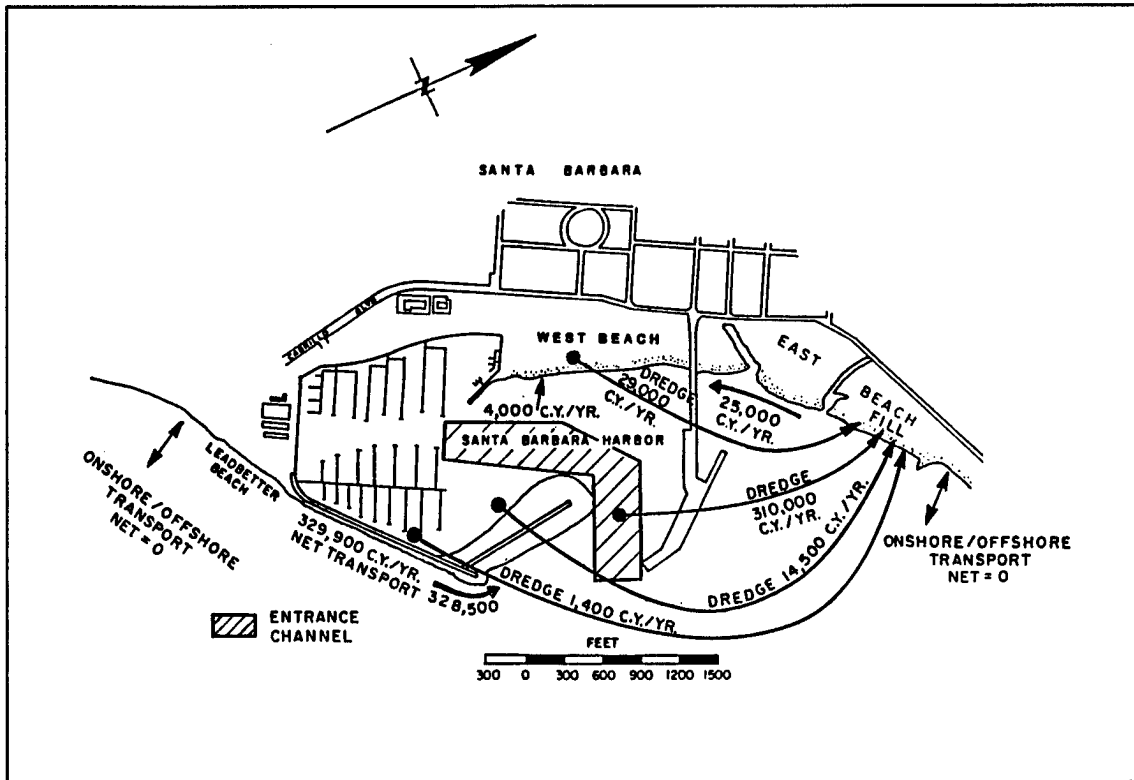

Figure 16. Sediment budget for Santa Barbara Harbor

The Corps Feasibility Study assesses six alternatives for maintaining the entrance channel and marina at Santa Barbara. These alternatives include the following:

- a. Modify dredge schedule.
- b. Modify dredge limits.
- c. Dedicated dredge.
- d. Structural sand trap.
- e. Fixed bypass plant on west breakwater.
- f. West beach groin.

This example uses *e*, the fixed bypass plant. Figures 17a and 17b show a sketch of this alternative. The bypass operation would consist of an array of fixed jet pumps with optional fluidizers, a portable jet pump, and various supply and discharge pipelines.

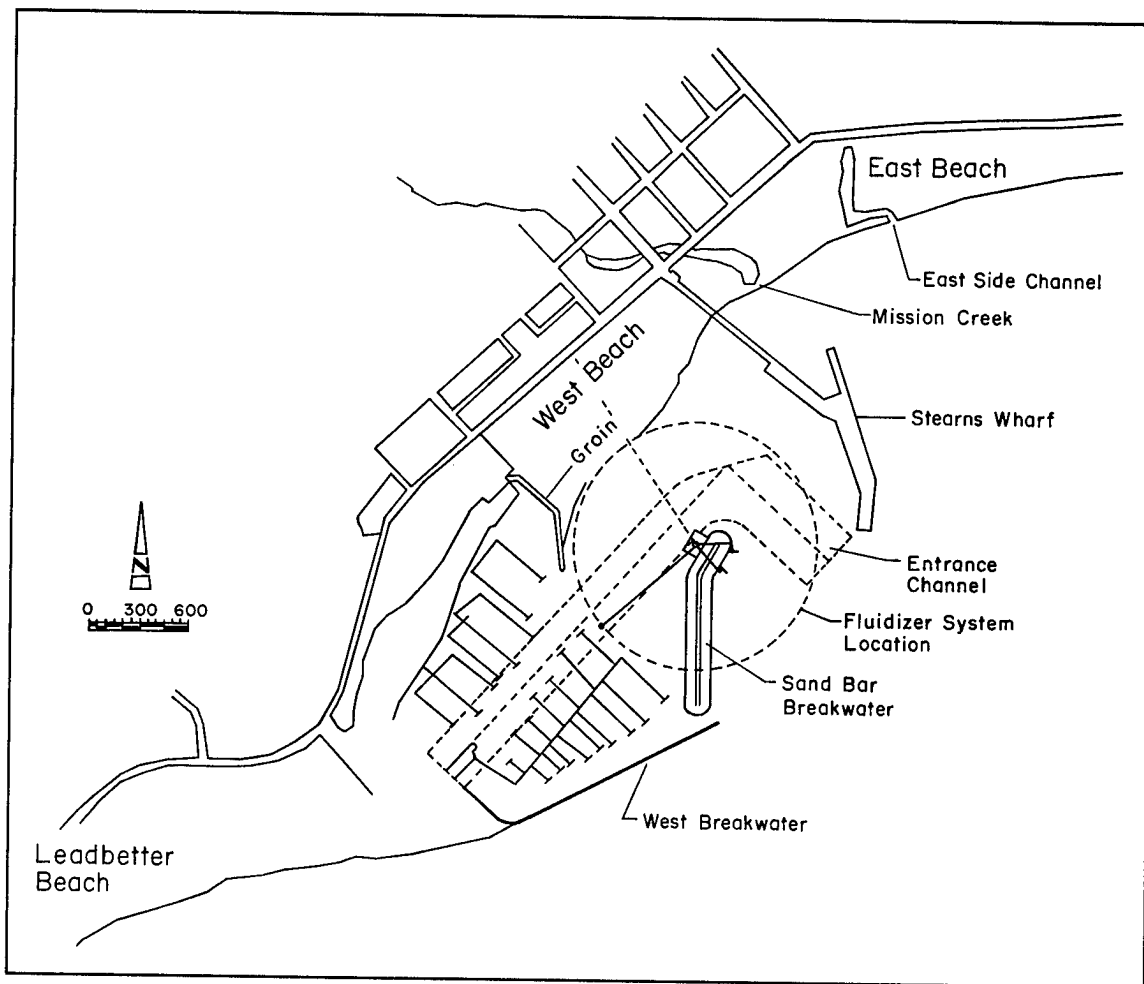

Figure 17a. Location of fluidizer system using the fixed bypass plant alternative showing general location

This example offers an analysis of the number and location of jet pump/fluidizer pairs.

The objectives of the project include:

- a. Prevention of shoaling of the marina and the entrance channel.
- b. Preservation of the sandbar, which acts as a breakwater. Thus, a balance must be maintained between "overdredging," which would reduce the effectiveness of the sandbar breakwater, and "underdredging," which would threaten the navigability of the entrance channel. It is important to note that there is much leeway (sediment storage available) between these two extremes. The portable jet pump shown in Figure 17b is used to "clean up" the entrance channel if there is westerly drift or if some easterly drift eludes the fluidizer trenches or jet pump craters. It is almost a 100 percent certainty that during storms with high littoral transport rates

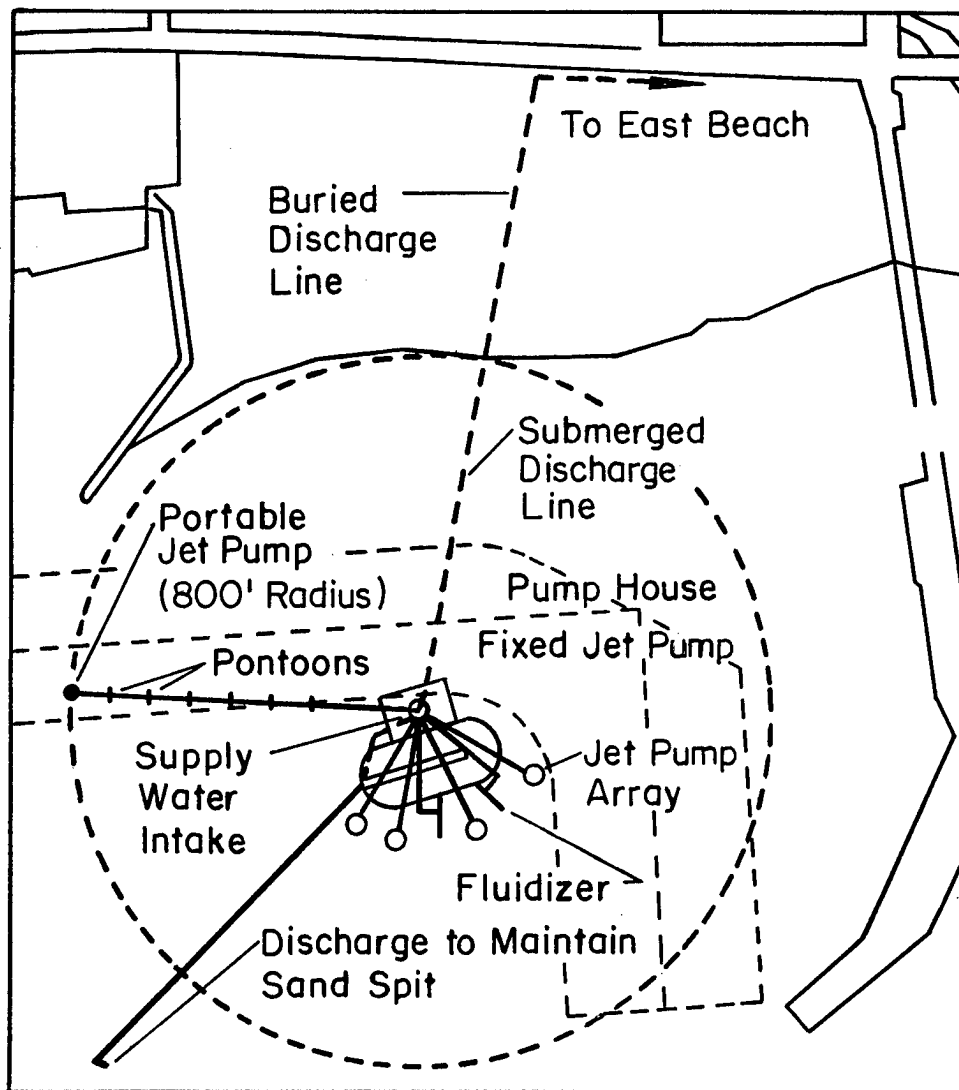

Figure 17b. Location of fluidization system components

some sand will get past the jet pump/fluidizer bypass system. Therefore a portable jet pump or small dredge will still be needed periodically.

The location, length, orientation, and number of fluidizers must be selected. Until more experience is gained with such systems, flexibility must be incorporated into the initial design layout to allow movement, addition, or removal of an individual jet pump/fluidizer system.

- a. First, it seems reasonable to orient the fluidizer pipes perpendicular to the main spine of the bar breakwater on the outside of the harbor. The pipes should slope slightly (1 percent) back toward the bar to deliver slurry to the jet pump located near the bar crest, as shown in Figure 18. This orientation will provide a trench with the most effective sediment trapping properties.

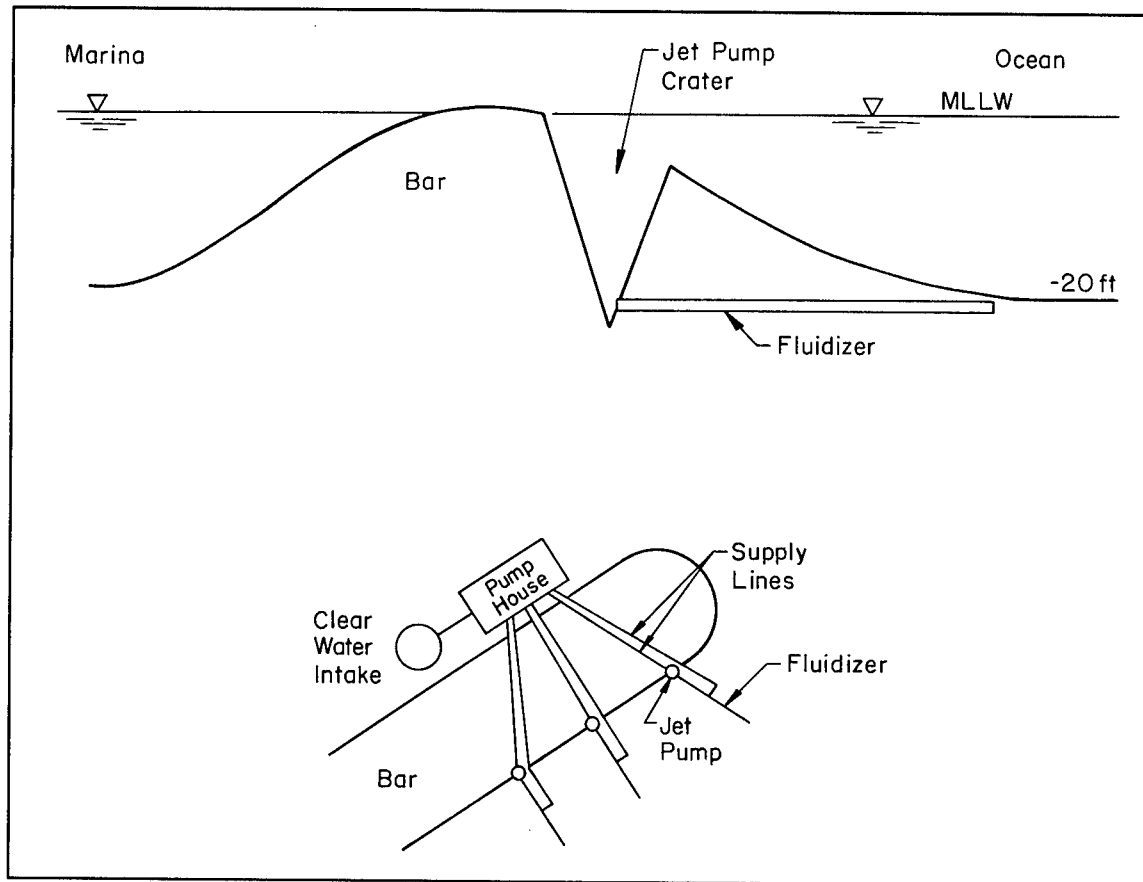

Figure 18. Section and plan views showing relative location of jet pump crater and fluidizer pipes, sandbar, pump house, and clear water intake

- b. Because the distance from MLLW to the 20-ft contour is approximately 200 ft, the fluidizer pipe can be 150-180 ft long from the 20-ft contour back to the jet pump crater. The approximate volume of material in the fluidizer trench is 1,000 yd³ and the volume of the crater is 700 yd³. To handle a large winter storm with a daily littoral drift of 4,600 yd³, three jet pump/fluidizer pairs would be needed (based on 200 yd³/hr × 8 hr/day × 3 = 4,800 yd³). This is a reasonable number until experience necessitates adding or removing some of the system.
- c. Location of the system should be centralized near the eastern end of the sandbar breakwater as shown in Figure 18. With this location, sediment will be intercepted before it enters the entrance channel but is not expected to create a breach in the breakwater. As shown in Figure 17b, the pump house and water supply intakes can be located on the protected side of the bar. Also, the discharge line distance is minimized by this location. Lastly, spacing of the jet pump/fluidizer combinations should be adequate to avoid overlapping of craters or trenches; a minimum of 80 ft between combinations will satisfy this requirement.

With three pairs of jet pumps/fluidizers in place and an average daily littoral drift of 900 yd³/day, only one pair will need to be operated on a particular day. The most western crater/trench will fill first and, in anticipation of storms, should be operated most frequently. Eventually, the middle system will fill and also require pumping. The eastern-most system will need pumping relatively infrequently. In response to storms, all three systems may require simultaneous operation (requiring a much larger and more expensive pumping system). Given a jet pump capacity of 200 yd³/hr, the crater/trench system can be emptied in 8.5 hr if there is minimal inflow over that time.

The calculation of the required full fluidization flow rate requires specification of the following parameters:

X_d = horizontal domain of sand (assumed to be virtually infinite).

Y_d = depth of sand layer below the pipe (assumed to be virtually infinite).

D = pipe diameter = assume 1 ft initially.

d_b = burial depth = varies from about 1 ft to 20 ft before jet pump crater is formed.

To be conservative, it is assumed that the burial depth is uniform at 16 ft, although the burial depth varies from 1 to 17 once the jet pump crater forms. From Figure 7, for the largest domain size and a relative burial depth of 16, the flow rate factor Q' / Kd_b is 2.75. Using a permeability based on sand grain size characteristics K of 0.0006 ft/sec, the incipient fluidization flow rate per unit length of pipe is 0.026 ft³/sec/ft. Using an F factor (see Chapter 2) of 5 gives a full fluidization flow rate per foot of pipe of 0.13 ft³/sec/ft. Multiplying this value by the 180-ft-pipe length gives the required total flow rate of 23.4 ft³/sec.

A pipe with a center feed is chosen. It would be difficult to feed the fluidizer from the jet pump crater end. To minimize the length of feed pipe, a center feed is preferred to feeding the fluidizer at the ocean end of the pipe. With center feed, 11.7 ft³/sec will flow in each direction. A pipe size of 14 in. will provide minimal variation of pressure head along the pipe. Although this diameter differs from the 1-ft diameter used above for flow rate, a recalculation shows a small change in required flow rate. See Appendix A for details.

The horizontally opposed holes should be spaced 1 to 2 in. apart, say 1.5 in. The hole size recommended should be 1/8 in. diameter or slightly smaller. In this example, there is an uneven distribution of sand over the fluidizer. With this situation, full fluidization can occur at the end of the pipe with shallow sand depth while the deeper bed remains unfluidized. Once this occurs, the flow distribution from the fluidizer can become nonuniform, with most of the flow emanating through holes into the fluidized end. Using small holes, where pressure in the pipe is maintained by head loss through the holes rather than through the bed, will minimize this nonuniform situation. Thus, a maximum hole size recommended here is 1/8 in.

For holes spaced 1.5 in. apart on each side of the pipe, the 180-ft-long pipe has 2,880 holes. For a total flow rate of 23.4 ft³/sec, the flow rate per hole Q_h is 0.0081 ft³/sec. The velocity through each hole is equal to the flow rate per hole divided by the area of the 1/8-in. hole, or 95 ft/sec. Equation 4 is used to calculate change in pressure head from inside to outside the fluidizer pipe:

$$\frac{\Delta p}{\gamma} = \frac{Q_h^2}{C_d^2 A_h^2 2g}$$

Using $Q_h = 0.0081$ ft³/sec, $C_d = 0.79$, and $A = 8.5 \times 10^{-5}$ ft², the pressure head change is 226 ft. Adding 20 ft of head for losses through the fully fluidized bed, the total pressure head requirement in the fluidizer pipe is 246 ft. The required head delivered by the pump must also take into consideration the losses between the clear water intake and the fluidizer, including pipe friction losses and all minor losses due to fittings, e.g. valves, elbows, etc.

References

- Bisher, D.R., and West, F.R. (1993). "Jet pumps and fluidizers working together: The oceanside experimental sand bypass system." *Proceedings of the 1993 Florida Shore and Beach Annual Beach Preservation Technology Conference*. St. Petersburg, FL, 207-22.
- Bottin, R.R., Jr. (1992). "Oceanside Harbor, California - Design for harbor improvements," Technical Report CERC-92-14, U.S. Army Engineer Waterways Experiment Station, Vicksburg, MS.
- Clausner, J.E., Neilans, P.J., Welp, T.W., and Bishop, D.D. (1994). "Controlled tests of eductors and submersible pumps," Miscellaneous Paper DRP-94-2, U.S. Army Engineer Waterways Experiment Station, Vicksburg, MS.
- Curren, C.R., and Chatham, C.E., Jr. (1980). "Oceanside Harbor and Beach, California, Design of structures for harbor improvement and beach erosion control; Hydraulic model investigation," Technical Report HL-80-10, U.S. Army Engineer Waterways Experiment Station, Vicksburg, MS.
- Dolan, T.J., Castens, P.G., Sonu, C.J., and Egense, A.M. (1987). "Review of sediment budget methodology: Oceanside littoral cell, California." *Proceedings of Coastal Sediments '87*, ASCE, NY, 1289-1304.
- Eckert, J. and Callender, G. (1987). "Geotechnical engineering in the coastal zone," Instruction Report CERC-87-1, U.S. Army Engineer Waterways Experiment Station, Vicksburg, MS.
- Hales, L.Z. (1978). "Coastal process study of the Oceanside, California littoral cell," Miscellaneous Paper H-78-8, U.S. Army Engineer Waterways Experiment Station, Vicksburg, MS.
- Inman, D.L., and Jenkins, S.A. (1983). "Oceanographic report for Oceanside beach facilities," prepared for City of Oceanside, CA.
- Kelley, J. T. (1977). "Fluidization applied to sediment transport," M.S. thesis, Lehigh University, Bethlehem, PA.

- Ledwith, C.A., Weisman, R.N., and Lennon, G.P. (1990). "Selection of hole size for fluidization pipes." *Proceedings of the National Hydraulics Conference*, ASCE, NY, 933-8.
- Lennon, G.P., and MacNair, W. (1991). "Three-dimensional predictions of incipient fluidization in fine sands in unbounded domains," Imbt Hydraulics Lab Report #IHL-132-91, Lehigh University, Bethlehem, PA.
- Lennon, G.P., Chang, F.T., and Weisman, R.N. (1990). "Predicting incipient fluidization of fine sand in unbounded domains," *Journal of Hydraulic Engineering*, ASCE, 116(HY12).
- McNown, J. S. (1953). "Mechanics of manifold flow." *Proceedings of ASCE*, 79(258).
- Marine Advisors, Inc. (1960). "Design waves for proposed small craft harbor at Oceanside, California." Prepared for U.S. Army Corps of Engineers, Los Angeles District, La Jolla, CA.
- Moffatt & Nichol, Engineers. (1983). "Phase 2 Report: Hydraulic calculations and drive system selection, experimental sand bypass system at Oceanside, California." Prepared for U.S. Army Engineer District, Los Angeles.
- _____. (1984). "Phase 3 Report: Final concept, experimental sand bypass system at Oceanside, California." Prepared for U.S. Army Engineer District, Los Angeles.
- _____. (1990). "Experimental sand bypass system - Oceanside, California, Phase II, Base plan - Basis for design." Prepared for U.S. Army Engineer District, Los Angeles.
- _____. (1994). "Sand bypass system - Oceanside Harbor, Oceanside, California, Phase III, Basis for design." Prepared for U.S. Army Engineer District, Los Angeles.
- Patterson, D.R., Bisher, D.R., and Brodeen, M.R. (1991). "The Oceanside experimental sand bypass system." *Proceedings of Coastal Sediments '91*, ASCE, NY, 1165-76.
- Richardson, T. W. and McNair, E. C. (1981). "A guide to the planning and hydraulic design of jet pump remedial sand bypassing systems," Instruction Report HL-81-1, U.S. Army Engineer Waterways Experiment Station, Vicksburg, MS.
- Shore Protection Manual*. (1984). 4th ed., 2 Vols., U.S. Army Engineer Waterways Experiment Station, Coastal Engineering Research Center, U.S. Government Printing Office, Washington, DC.

U.S. Army Corps of Engineers. (1984). "Hydraulic design of small boat harbors," Engineer Manual 1110-2-1615, Washington, DC.

_____. (1991). "Sand bypassing system selection," Engineer Manual 1110-2-1616, Washington, D.C.

U.S. Army Engineer District, Los Angeles (1990). "Santa Barbara Harbor - draft feasibility study."

Walker, J.R., Jr., and Lesnik, J.R. (1990). "Impacts of ocean entrances on beaches in Southern California." *Proceedings of the 1990 National Conference on Beach Preservation Technology*. Florida Shore and Beach Preservation Association, Tallahassee, FL, 203-17.

Weisman, R.N., and Collins, A.G. (1979). "Stabilization of tidal inlet channels - Design recommendations," Fritz Engineering Laboratory Report No. 710.3, Lehigh University, Bethlehem, PA.

Weisman, R.N., Clifford, J.T., and Lennon, G.P. (1990). "Slurry removal from a 2-D fluidized region." *Proceedings of the National Hydraulics Conference*, ASCE, NY, 1263-9.

Weisman, R.N., Collins, A.G., and Parks, J.M. (1982). "Maintaining tidal inlet channels by fluidization," *Journal of the Waterway, Port, Coastal, and Ocean Division*, ASCE, 108(WW4).

Weisman, R.N., Roberts, E.W., and Lennon, G.P. (1988). "Experiment on fluidization in unbounded domains," *Journal of Hydraulic Engineering*, ASCE, 114(HY5).

Weisman, R.N., Demchak, S.J., and Lennon, G.P. (1991). "Fluidization pipe hole spacing." *Proceedings of the National Hydraulics Conference*, ASCE, NY, 142-7.

Appendix A

Pipe Size Design

The goal of pipe size design for a fluidizer pipe is selection of a pipe diameter that minimizes pressure change along the pipe. If the pressure remains fairly constant down the pipe, then the flow emanating from the fluidizer holes will be uniform. This will ensure uniform fluidization of the overlying sand. The relevant equations for analyzing this problem have been developed previously for manifold problems (McNown 1953).

The energy equation is written between two cross sections of a fluidizer pipe shown in Figure A1:

$$\frac{V_1^2}{2g} + \frac{p_1}{\gamma} + z_1 = \frac{V_2^2}{2g} + \frac{p_2}{\gamma} + z_2 + h_L \quad (A1)$$

where

V = average velocity in the pipe at a cross section

p = average pressure at a cross section

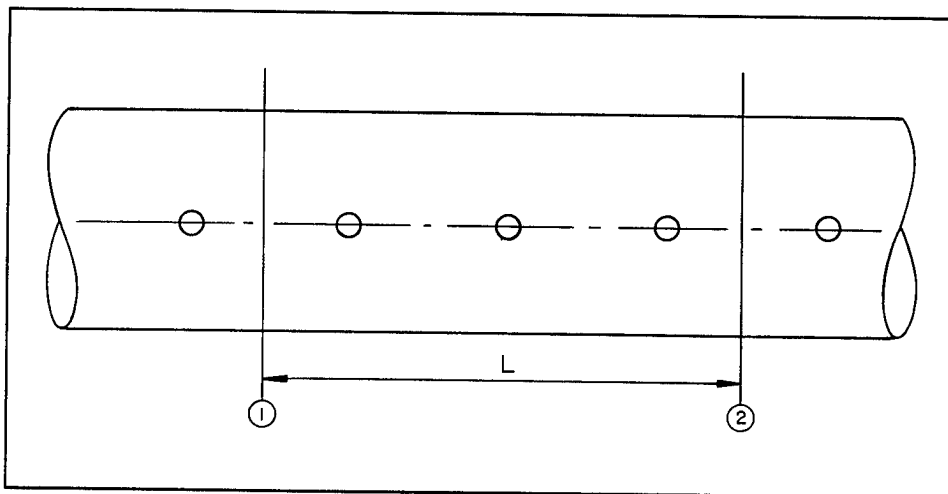

Figure A1. Fluidizer pipe showing holes and sections 1 and 2 where the energy equation is applied to determine pipe diameter

z = elevation of the pipe centerline from a horizontal datum

h_L = head loss between sections 1 and 2

g = acceleration of gravity (32.2 ft/sec²)

γ = specific weight of the fluid in the pipe (62.4 lb/ft³ for fresh water and 64.0 lb/ft³ for seawater).

Assuming a horizontal pipe and rearranging Equation A1 gives the following equation for the pressure head drop along the pipe from section 1 to 2:

$$\frac{p_1 - p_2}{\gamma} = \frac{V_2^2 - V_1^2}{2g} + h_L \quad (\text{A2})$$

For a constant diameter pipe, the change in velocity occurs because discharge is lost along the pipe. Using the continuity equation ($Q_1 = V_1 A_1$, $Q_2 = V_2 A_2$), Equation A2 can be rewritten as follows:

$$\frac{p_1 - p_2}{\gamma} = \frac{Q_2^2 - Q_1^2}{2g A^2} + h_L \quad (\text{A3})$$

where A is the constant pipe cross-sectional area.

Because $Q_2 < Q_1$, the first term on the right-hand side of Equation A3 is negative. The head loss h_L is always positive in the direction of flow. Obviously, if the two terms on the right-hand side just offset each other, then the pressure head change $p_1/\gamma - p_2/\gamma$ will be zero. To achieve this, the appropriate pipe diameter must be selected.

Using the Darcy-Weisbach equation for head loss, Equation A3 can be written as follows:

$$\frac{p_1 - p_2}{\gamma} = \frac{Q_2^2 - Q_1^2}{2g \left(\frac{\pi}{4}\right)^2 D^4} + f \frac{L}{2g} \frac{Q^2}{\left(\frac{\pi}{4}\right)^2 D^5} \quad (\text{A4})$$

where the flow rate Q in the last term is taken as the average flow rate between sections 1 and 2, f is the friction factor calculated using the procedure outlined below, and L is the distance along the pipe from section 1 to 2 and the area is written in terms of the diameter, $A = D^2\pi/4$. Note that if D is relatively large, the terms on the right-hand side of Equation A4 become small. This is a general property of manifolds; a very large pipe will satisfy the design goal. For cost savings, the smallest diameter pipe that meets the goal is desired. To determine the appropriate diameter D , Equation A4 is solved using several values of pipe diameter, and a plot of pressure head p/γ versus distance along the pipe L can be made. The diameter that gives a reasonably constant value of pressure head

should be selected. Note that, if the pipe is not horizontal, Equation A3 should include the change in elevation head $z_2 - z_1$. For the small slopes (1 to 2 percent) used in fluidizer applications, it is reasonable to neglect $z_2 - z_1$ in comparison to other terms on the right side of Equation A4.

The calculations should begin from the point where the feed pipe delivers total flow Q_T to the fluidizer pipe. At this cross section, the pressure head is calculated using the methodology discussed in Chapter 2. The other parameter required for these calculations is an appropriate roughness coefficient, which depends on selection of pipe material. Note that the friction factor is a constant for high Reynolds numbers, but will change along the pipe as the Reynolds number changes in the transition region of the Moody diagram (see any fluid mechanics text). This is shown in the examples below.

Example 1

The first example is continued here to illustrate how a pipe diameter is selected. The pertinent design data are as follows:

- Total flow rate = 36 ft³/sec
- Pipe length = 400 ft
- Center feed, 18 ft³/sec in each direction
- Hole spacing = 1.5 in.
- Hole diameter = 1/8 in.
- Flow rate per hole = 5.625×10^{-3} ft³/sec

- a. The first step is to approximate the friction factors over the length of the pipe. Three trial pipe diameters are selected: 12, 14, and 18 in. The pipe is assumed to be plastic or lined with plastic and the equivalent sand grain roughness ϵ is assumed to be 5×10^{-6} ft. Values of equivalent sand grain roughness can be obtained from any fluid mechanics text or from commercial pipe manufacturers' literature. The pipe properties are given in Table A1.

Pipe Diameter, in.	Pipe Area, ft ²	Relative Roughness, ϵ/D
12	0.785	5×10^{-6}
14	1.068	4.3×10^{-6}
18	1.766	3.3×10^{-6}

The length of pipe from the center feed to the pipe end, 200 ft, is divided into increments, and at each cross section, Reynolds number is calculated and the friction factor is obtained from the Moody diagram, as shown in Table A2. Because the relative roughness is so small, the pipe acts as a hydraulically smooth pipe (lowest curve in Moody diagram) over the range of Reynolds numbers considered here. Note, a value of 1.2×10^{-5} ft²/sec is used for kinematic viscosity of seawater at 60° F in calculating the Reynolds number.

- b. The next step is to calculate the pressure head change along the pipe from the center feed ($x = 0$) to the end of the pipe ($x = 200$ ft). This is accomplished by using Equation A4 and is shown in Table A3. The same sections are used below as were used above to calculate Reynolds numbers and friction factors. An example of these calculations for Table A3 is given as follows by considering sections 3 to 4 ($i = 3, i + 1 = 4$) and a 14-in. pipe.

$$\text{Column 4: } \frac{Q_4^2 - Q_3^2}{2g \left(\frac{\pi}{4}\right)^2 D^4} = \frac{4.5^2 - 9.0^2}{2(32.2) \left(\frac{\pi}{4}\right)^2 \left(\frac{14}{12}\right)^4} = -0.83$$

where D is 14/12 ft.

$$\begin{aligned} \text{Column 5: } f \frac{L}{2g} \frac{Q^2}{\left(\frac{\pi}{4}\right)^2 D^5} &= 0.0128 \frac{50}{2(32.2)} \frac{\left[\frac{(4.5 + 9.0)}{2}\right]^2}{\left(\frac{\pi}{4}\right)^2 \left(\frac{14}{12}\right)^5} \\ &= 0.34 \end{aligned}$$

where $f = 0.0128$ is read from the Moody diagram using smooth pipe (lowest curve) and a Reynolds number of

$$R = \frac{VD}{\nu} = \frac{QD}{Av} = \frac{\left(\frac{4.5 + 9.0}{2}\right) \left(\frac{14}{12}\right)}{(1.068)(1.2 \times 10^{-5})} = 6.2 \times 10^5$$

where the area A is obtained from Table A1.

$$\text{Column 6: } \frac{P_i - P_{i-1}}{\gamma} = \text{Column 4} + \text{Column 5} = -0.49$$

**Table A2
Reynolds Numbers and Friction Factors, Example 1**

Distance from Feed Pipe, ft	Flow Rate, ft ³ /sec	Reynolds Number, VD^v , for Pipe Diam			Friction Factor, f , for Pipe Diam			Average Friction Factor in section for Pipe Diam		
		12 in.	14 in.	18 in.	12 in.	14 in.	18 in.	12 in.	14 in.	18 in.
0	18.0	1.9×10^6	1.6×10^6	1.3×10^6	0.0105	0.0108	0.0113			
50	13.5	1.4×10^6	1.2×10^6	9.5×10^5	0.0110	0.0115	0.0120	0.0108	0.0111	0.0115
100	9.0	9.5×10^5	8.2×10^5	6.4×10^5	0.0120	0.0122	0.0125			
150	4.5	4.8×10^5	4.1×10^5	3.2×10^5	0.0130	0.0135	0.0141	0.0125	0.0128	0.0133
175	2.25	2.4×10^5	2.0×10^5	1.6×10^5	0.0150	0.0158	0.0162	0.0140	0.0147	0.0157
195	0.45	4.8×10^4	4.1×10^4	3.2×10^4	0.021	0.0217	0.0230	0.0180	0.0187	0.0196
200	0	—	—	—	—	—	—	0.030'	0.030'	0.030'

¹ Values are assumed.

**Table A3
Pressure Head Changes, Example 1**

(1)	(2)	(3)	(4)			(5)			(6)			(7)		
	Distance from Feed Pipe, ft	Flow Rate, ft ³ /sec	$\frac{Q_2^2 - Q_1^2}{2g \left(\frac{\pi}{4}\right)^2 D^4}$ + $f \frac{L}{2g} \frac{Q_2^2}{\left(\frac{\pi}{4}\right)^2 D^5} =$			$\frac{P_1 - P_{1-1}}{Y}$			$\left(\frac{P}{Y}\right)^{1/4} - \left(\frac{P}{Y}\right)^{1/4}$					
Section i			For Pipe Diam			For Pipe Diam			For Pipe Diam					
			12 in.	14 in.	18 in.	12 in.	14 in.	18 in.	12 in.	14 in.	18 in.			
1	0	18.0	--	--	--	--	--	--	--	--	0	0	0	
2	50	13.5	-3.57	-1.93	-0.70	3.38	1.61	0.47	-0.19	-0.32	-0.24	0.19	0.32	0.24
3	100	9.0	-2.55	-1.38	-0.50	1.80	0.87	0.26	-0.75	-0.51	-0.25	0.94	0.83	0.48
4	150	4.5	-1.53	-0.83	-0.30	0.71	0.34	0.10	-0.82	-0.49	-0.20	1.76	1.32	0.69
5	175	2.25	-0.38	-0.21	-0.08	0.10	0.05	0.01	-0.28	-0.16	-0.06	2.04	1.47	0.75
6	195	0.45	-0.12	-0.07	-0.02	0.02	0.01	0.00	-0.10	-0.06	-0.02	2.14	1.53	0.77
7	200	0	-0.01	-0.00	-0.00	0.00	0.00	0.00	-0.01	0	0	2.15	1.53	0.77

Note: Values are assumed.

$$\begin{aligned} \text{Column 7: } \left(\frac{P}{\gamma}\right)_{i=1} - \left(\frac{P}{\gamma}\right)_{i=4} &= 0 - (-0.32 + -0.51 + -0.49) \\ &= 1.32 \end{aligned}$$

Using more sections (or smaller Δx on a finite difference sense) will give greater accuracy. However, the section lengths chosen will give sufficient accuracy to choose a proper pipe diameter. From the results shown in Table A3 and Figure A2, the 12-in. pipe keeps the pressure head within about 2 ft of the center pressure head at the center feed point, which is 109 ft.

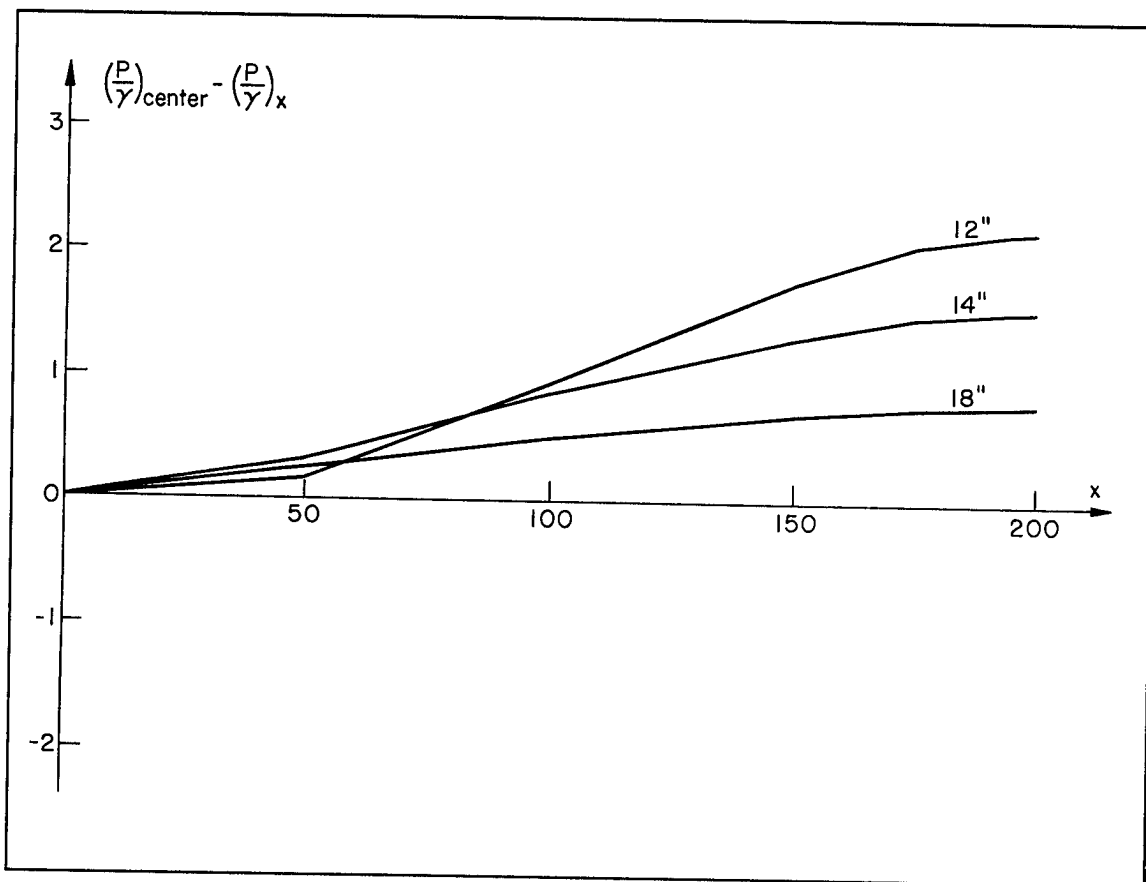

Figure A2. Variation of pressure head from center-feed pressure head inside and along fluidization pipe, Example 1

Example 2

The second example is continued here for pipe size determination. The pertinent design data are as follows:

Total flow rate = 23.4 ft³/sec
 Pipe length = 180 ft
 Center feed, 11.7 ft³/sec in each direction
 Hole spacing = 1.5 in.
 Hole diameter = 1/8 in.
 Flow rate per hole = 0.0081 ft³/sec

- a. The first step is to approximate the friction factors over the length of the pipe. Start by assuming three pipe sizes: 10-, 12-, and 14-in. diameters. Also assume that the pipe is plastic and the equivalent sand grain roughness ϵ is 5×10^{-6} ft. The pipe properties are shown in Table A4. Because the relative roughness is so small, the pipe acts as a hydraulically smooth pipe (lowest curve in Moody diagram) over the range of Reynolds numbers considered here.

Pipe Diameter, in.	Pipe Area, ft ²	Relative Roughness, ϵ/D
10	0.545	6.0×10^{-6}
12	0.785	5.0×10^{-6}
14	1.068	4.3×10^{-6}

The length of pipe from the center feed to the pipe end, 90 ft, is divided into increments, and at each cross section, Reynolds number is calculated and the friction factor f is obtained from the Moody diagram, as shown in Table A5. A value of 1.2×10^{-5} ft²/sec is used for kinematic viscosity.

- b. The next step is to calculate the pressure head change along the pipe from the center feed ($x = 0$) to the end of the pipe ($x = 90$ ft). This is accomplished by using Equation A4. The same sections are used below as were used above to calculate Reynolds numbers and friction factors. Using more sections (or smaller Δx on a finite difference sense) will give greater accuracy. However, the section lengths chosen will give sufficient accuracy to choose a proper pipe diameter. From the results, shown in Table A6 or in Figure A3, the 14-in. pipe keeps the pressure head within about 1.5 ft of the center pressure head, which is 246 ft. However, the 12-in. pipe or even the 10-in. pipe could be used without causing the pressure to vary considerably along the pipe.

As a general rule, the pipe diameter should be large enough to:

- a. Avoid more than a 10 percent change in pressure head along the pipe.
 b. Avoid an average velocity in the pipe that exceeds 30 ft/sec.

Table A5 Reynolds Numbers and Friction Factors, Example 2												
Distance from Feed Pipe, ft	Flow Rate, ft ³ /sec	Reynolds Number, VD^v , for Pipe Diam			Friction Factor, f , for Pipe Diam			Average Friction Factor in Section for Pipe Diam				
		10 in.	12 in.	14 in.	10 in.	12 in.	14 in.	10 in.	12 in.	14 in.		
0	11.7	1.5×10^6	1.2×10^6	1.1×10^6	0.0110	0.0115	0.0115					
20	9.1	1.2×10^6	9.7×10^5	8.3×10^5	0.0115	0.0117	0.0118	0.0113	0.0116		0.0117	
40	6.5	8.3×10^5	6.9×10^5	5.9×10^5	0.0118	0.0125	0.0128					0.0123
60	3.9	5.0×10^5	4.1×10^5	3.5×10^5	0.0130	0.0135	0.0138	0.0124	0.0130			0.0133
80	1.3	1.7×10^5	1.4×10^5	1.2×10^5	0.0160	0.0168	0.0173	0.0145	0.0152			0.0156
90	0	--	--	--				0.030'	0.030'			0.030'

¹ Values are assumed.

**Table A6
Pressure Head Changes, Example 2**

(1)	(2)	(3)	(4)				(5)				(6)				(7)					
Section i	Distance from Feed Pipe, ft	Flow Rate, ft ³ /sec	$\frac{Q_2^2 - Q_1^2}{2g \left(\frac{\pi}{4}\right)^2 D^4} + f \frac{L}{2g} \left(\frac{\pi}{4}\right)^2 D^5 = \frac{P_i - P_{i-1}}{V}$												$\left(\frac{P}{V}\right)_{i-1} - \left(\frac{P}{V}\right)_{i-4}$					
			For Pipe Diam				For Pipe Diam				For Pipe Diam				For Pipe Diam					
			10 in.	12 in.	14 in.	10 in.	12 in.	14 in.	10 in.	12 in.	14 in.	10 in.	12 in.	14 in.	10 in.	12 in.	14 in.	10 in.	12 in.	14 in.
1	0	11.7					0										0	0	0	
2	20	9.1	-2.83	-1.36	-0.74	1.53	0.63	0.29	-1.30	-0.73	-0.45	1.30	0.73	0.45	1.30	0.73	0.45	1.30	0.73	0.45
3	40	6.5	-2.12	-1.02	-0.55	0.89	0.87	0.17	-1.23	-0.65	-0.38	2.53	1.38	0.83	2.53	1.38	0.83	2.53	1.38	0.83
4	60	3.9	-1.41	-0.68	-0.37	0.42	0.34	0.08	-0.99	-0.50	-0.29	3.52	1.88	1.12	3.52	1.88	1.12	3.52	1.88	1.12
5	80	1.3	-0.71	-0.34	-0.18	0.12	0.05	0.02	-0.59	-0.29	-0.16	4.11	2.17	1.28	4.11	2.17	1.28	4.11	2.17	1.28
6	90	0	-0.09	-0.04	-0.02	0.01	0.01	0.00	-0.08	-0.04	-0.02	4.19	2.21	1.30	4.19	2.21	1.30	4.19	2.21	1.30

Note: Values are assumed.

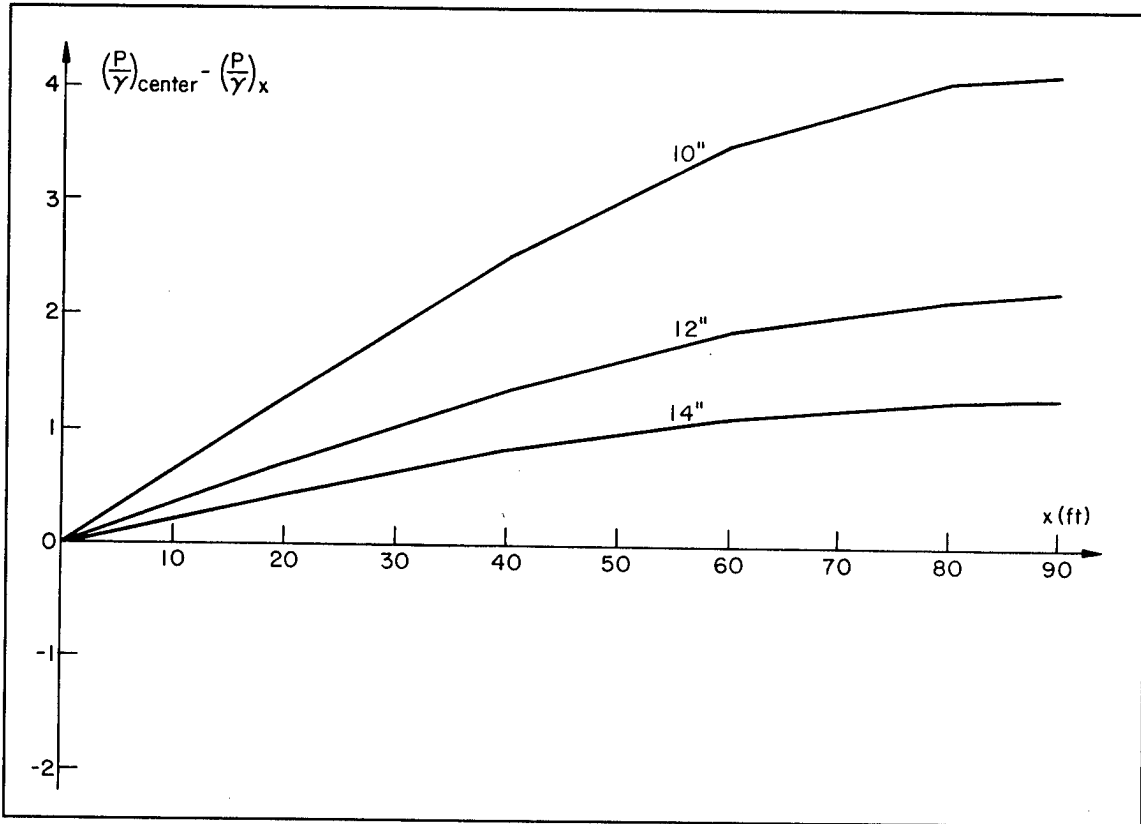

Figure A3. Variation of pressure head from center-feed pressure head inside and along fluidization pipe, Example 2

Appendix B

Fluidizer Experience at the Oceanside Sand Bypass Plant

As the first large-scale fluidizer project conducted by the Corps of Engineers, experience from the Oceanside Sand Bypass project should be valuable for other bypass projects. To put the fluidizer experience in the proper context, a moderate amount of background information on the overall Oceanside Sand Bypass project is provided.

Project History/Coastal Processes

Oceanside, California, is located on the southern California coast about 35 miles northwest of San Diego (Figure B1). In 1942, the Navy constructed two jetties at the entrance to the Del Mar Boat Basin located at the west end of Oceanside. Very soon the entrance channel began to shoal at high rates due to the large amount of littoral drift. Prior studies of coastal processes at Oceanside (Marine Advisors 1960, Hales 1978, Inman and Jenkins 1983, Dolan et al. 1987) have produced gross sediment transport estimates at this location of approximately 1,200,000 yd³ per year with an annual net transport of 100,000 to 250,000 yd³ to the south. As might be expected with such large amounts of littoral transport, entrance channel shoaling has continued to be a problem since the entrance channel structures were constructed.

Periodically over the years the harbor entrance structures have been expanded in an effort to reduce entrance channel shoaling (Figure B2), with the major expansion occurring during the early 1960's when the Oceanside Small Craft Harbor was constructed. In 1994, the most recent construction was completed, consisting of a spur groin on the south jetty and a seaward extension of the north jetty. These latest modifications are designed to increase navigation safety and reduce wave heights inside the harbor (Bottin 1992).

In addition to channel shoaling, erosion of the downdrift beaches has also been a problem at Oceanside, attributable to the entrance channel structures and dams on area rivers which greatly reduce sand supplied by floods (Walker and

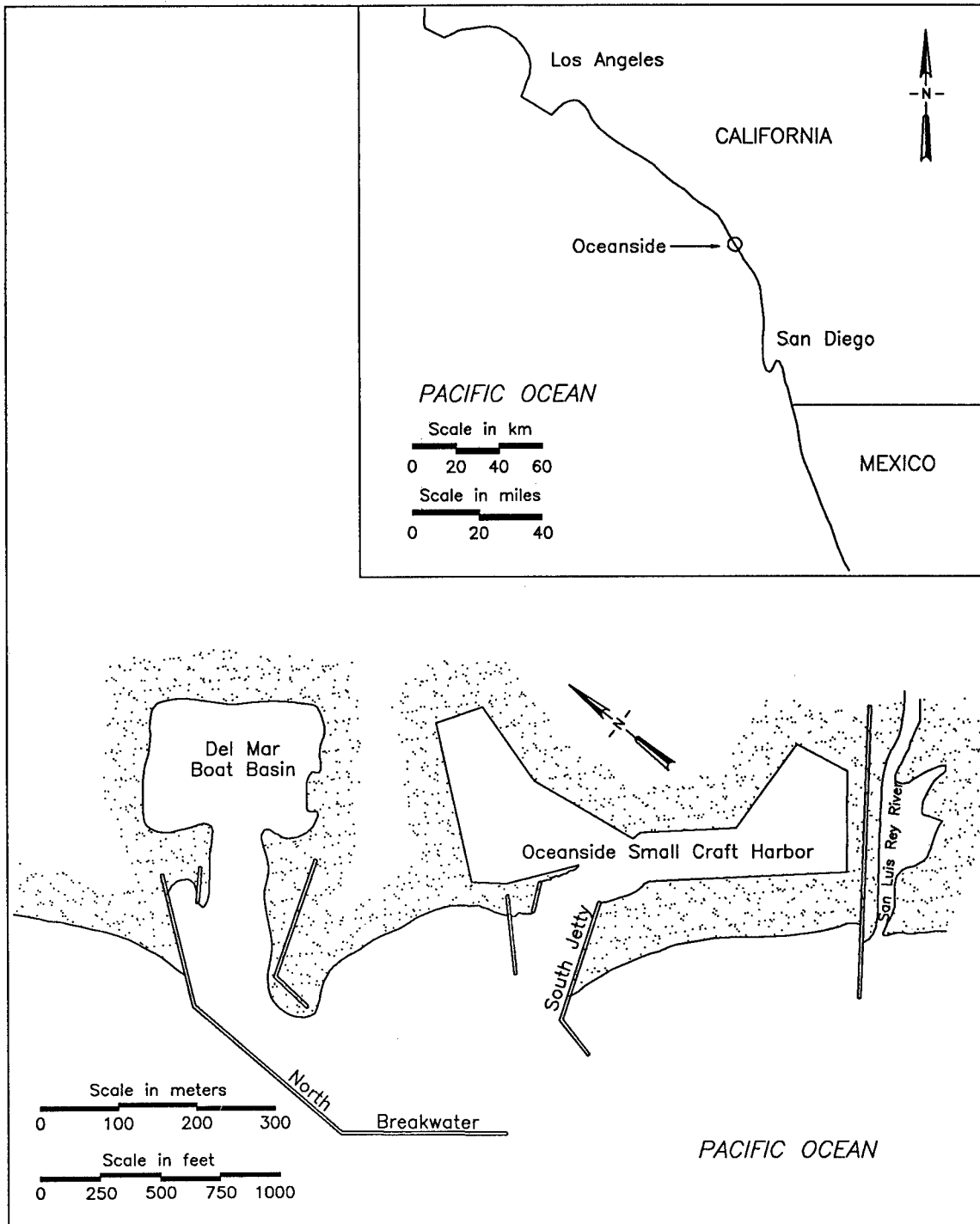

Figure B1. Location map, Oceanside sand bypass system

Lesnik 1990). While all the sediment dredged from the harbor since 1957 has been placed on the downdrift beaches (totaling over 10,000,000 yd³ through 1993), beach erosion continues to be a major problem.

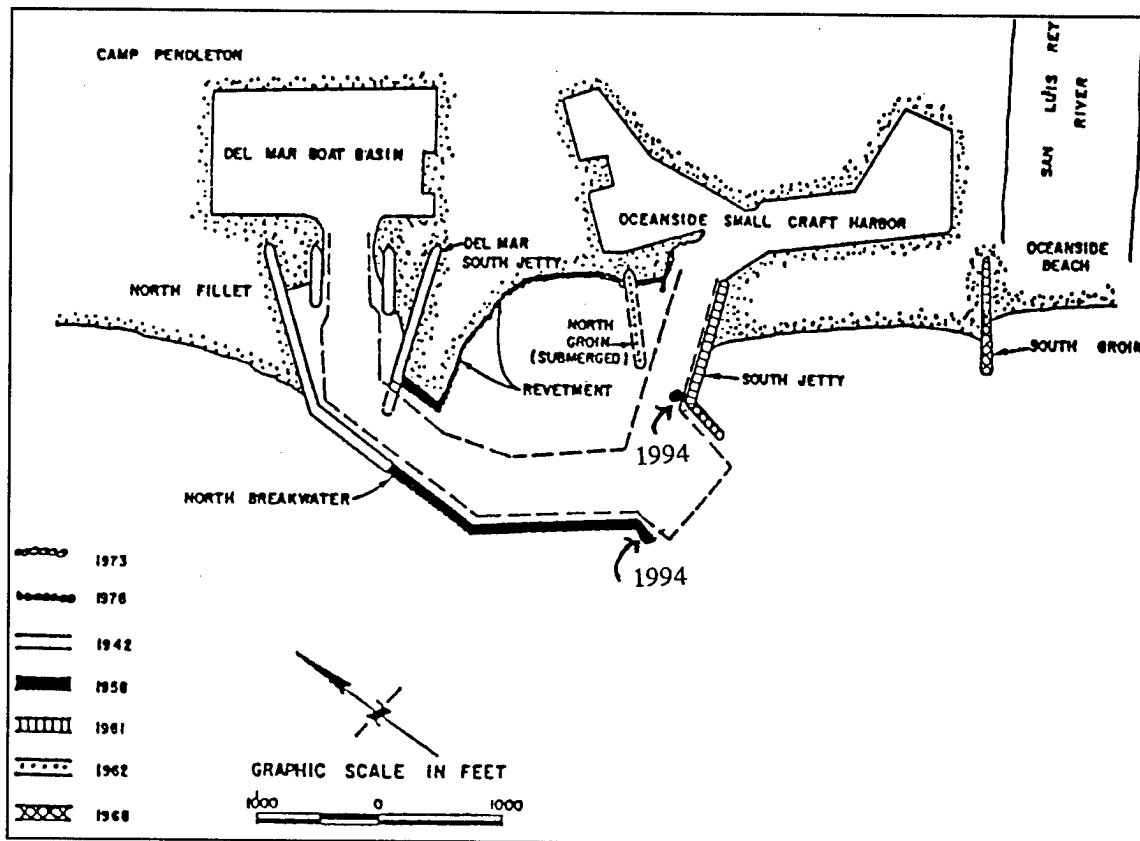

Figure B2. Oceanside Harbor structures (after Walker and Lesnik (1990))

Sand bypassing has been considered at Oceanside since the late 1970's. However, the difficult conditions at the site, large amounts of sand transport in both directions, no concentrated areas of deposition, and high waves make Oceanside a most challenging site for a fixed sand bypassing plant to be effective. Local concerns over beach erosion led to pressure on Congress resulting in 1982 Congressional legislation requiring that an experimental sand bypass plant be constructed at Oceanside. Planning studies considered a number of options to either reduce beach erosion rates or increase effectiveness of a fixed bypass plant. Structural options included (a) modifying the existing jetties to concentrate capture areas for sand bypassing, and (b) the use of detached breakwaters and a terminal groin to reduce downdrift beach erosion (Curren and Chatham 1980). Proposed bypassing/backpassing options included two relatively predictable schemes: mining of the north (updrift) fillet, located on the Camp Pendleton U.S. Marine Corps Base Property (rejected by the local base commander), and mining of the fillet between the south jetty and San Luis Rey Groin (rejected by the City of Oceanside). The elimination of other, more predictable options, resulted in the selection of a unique bypassing scheme, using a fixed plant to bypass sand from the entrance channel.

This unique application of sand bypassing technology justified the experimental nature of the project. The plan for the experimental plant used phased construction, allowing testing and verification of each phase prior to

proceeding to the next phase. The primary stated purpose of the bypassing plant was to reduce channel maintenance dredging costs.

The bypass system constructed at Oceanside was based on fixed jet pumps. The large amounts of littoral sediments that move in both directions led to design of a unique system that could bypass sand from two locations. As originally designed, bypassing from the entrance channel was to occur when the primary littoral drift direction is to the north (April - October), and from the north breakwater during the rest of the year when the primary direction of sand transport is to the south (November - March). Bypassing from two locations is accomplished by having the main pumps and controls mounted in trailers attached to a barge that can be moved between the different locations (Figure B3). A shore booster pump is used when bypassing from the north fillet. Details on the bypass system design can be found in reports by Moffatt and Nichol, Engineers (1983 and 1984). Grain size of the sand bypassed has a D_{50} of 0.18 to 0.21 mm.

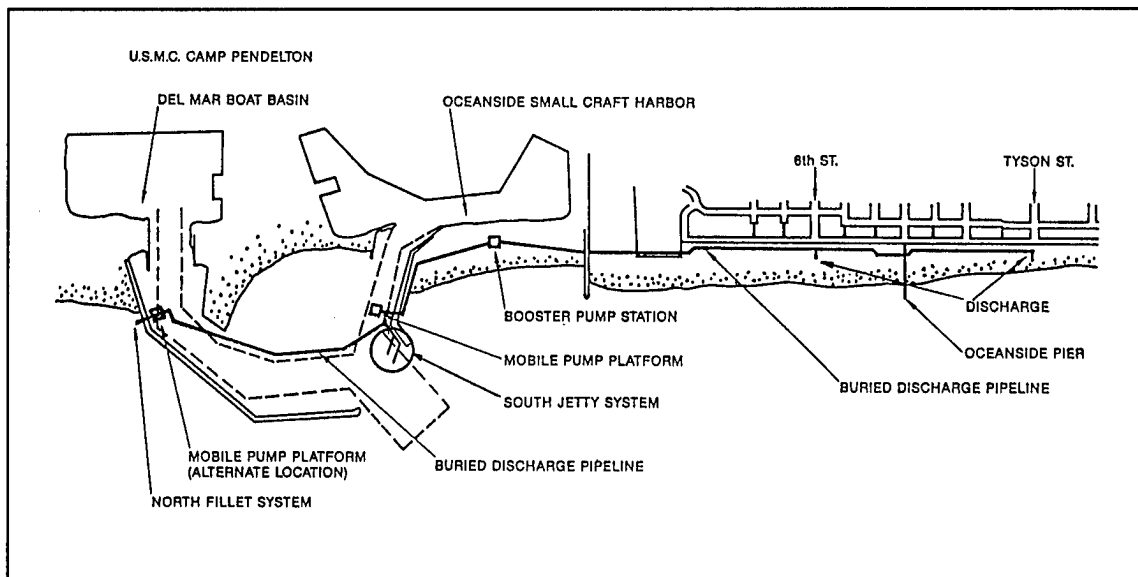

Figure B3. Bypass system locations (Patterson, Bisher, and Brodeen 1991)

Phase I Operations

The initial bypass system (Figure B3) consisted of the barge with the associated pumps and controls, north and south jetty riser structures, a single crane-deployed jet pump at the north jetty, two entrance channel jet pumps adjacent to the south jetty and associated undersea pipelines, the cross harbor pipeline, and shore booster station (the discharge line along the beach was installed earlier). During operations the main booster pump barge is hoisted out of the water to provide a stable platform and protection from storm waves. Phase I operations began in June 1989 with three weeks of operation from the

north fillet, followed by operations from the entrance channel from July 1989 through August 1990. Patterson, Bisher, and Brodeen (1991) describe system performance during that period; Table B1 summarizes Phase I data.

Note that fluidizers were part of the Phase I operation; however, these were deployment fluidizers placed on the jet pump supporting beams. The fluidizers were used to assist in deploying and retrieving the jet pumps.

Phase I was considered successful because all the major components of the system functioned more or less as designed (Patterson, Bisher, and Brodeen 1991). The 4-in. x 4-in. x 6-in. Pekor jet pumps used in the entrance channel were able to bypass sand, though the overall average (63 yd³/hr) was well below the design value of 200 yd³/hr. During the 11 months of operation, only 18,300 yd³ of sand were bypassed. While in operation, the jet pumps maintained craters 15 ft deep and 80 ft in diameter.

Table B1 Phase I Production History					
Date	Total Operational Hours	Pumping Sand Hours	Total yd ³ Pumped	Production Rate (yd ³ /hr)	
				Avg	Max
Jun 89	15	2	42	21	38
Jul 89	38	12	167	14	34
Aug 89	60	4	64	16	42
Sep 89	82	18	234	13	76
Oct 89	84	25	1,403	56	116
Nov 89	92	32	1,540	48	104
Dec 89	54	21	1,386	66	109
Jan 90	Plant Inoperative				
Feb 90	Plant Inoperative				
Mar 90	Plant Inoperative				
Apr 90	Plant Inoperative				
May 90	74	51	3,658	72	155
Jun 90	92	55	4,070	74	123
Jul 90	76	44	2,356	53	135
Aug 90	77	41	3,362	82	150
Totals	744	305	18,282	60	
Adapted from Patterson, Bisher, and Brodeen (1991).					

While clogging of the jet pumps was a continual problem (kelp root balls and rope were debris sources), a major reason more sand was not bypassed was the small area of influence of each jet pump. Once a crater is emptied, no sand can be bypassed until sediment transport supplies additional sand. This is a particular problem when attempting to bypass using the entrance channel jet pumps (located adjacent to the south jetty) during the winter months when most of the sand comes from the north and deposits near the tip of the north breakwater.

Phase II Design

The major improvement for Phase II was the addition of fluidizers to expand the capture area of the entrance channel jet pumps. Two sand trap fluidizers, one feeding each of the jet pumps, were added. While consideration was given to using longer fluidizers (up to 400 ft long) and the testing of different fluidizer pipe materials, cost considerations limited the system to that shown in Figure B4 and summarized in Table B2. A 200-ft-long fluidizer was used to feed the south jet pump and a 150-ft-long fluidizer provided sand to the north fluidizer. Cost considerations also eliminated the purchase of a separate fluidizer pump that would have allowed simultaneous operation of the fluidizers and jet pumps.

Sand trap fluidizer design

The primary attributes of fluidizer design at the Oceanside sand bypass plant, hole spacing, orientation, diameter, exit velocity, flow rate, and pressure requirements were based on available information on fluidization at the time of system design as summarized in Weisman, Collins, and Parks (1982). Weisman's design recommendations were adapted for this project by Moffatt and Nichol, Engineers (1990). Table B3 presents the fluidizer hole size, spacing, and orientation and the other hydraulic design values for this project.

Characteristic	North Sand Trap Fluidizer	South Sand Trap Fluidizer
Pipe material	HDPE	HDPE
Length	150 ft	200 ft
Diameter	8 in.	10 in.
Slope	1V:75H	1V:100H
Outer elevation	25.0 ft	25.0 ft
Inner elevation (at jet pump)	27.0 ft	27.0 ft

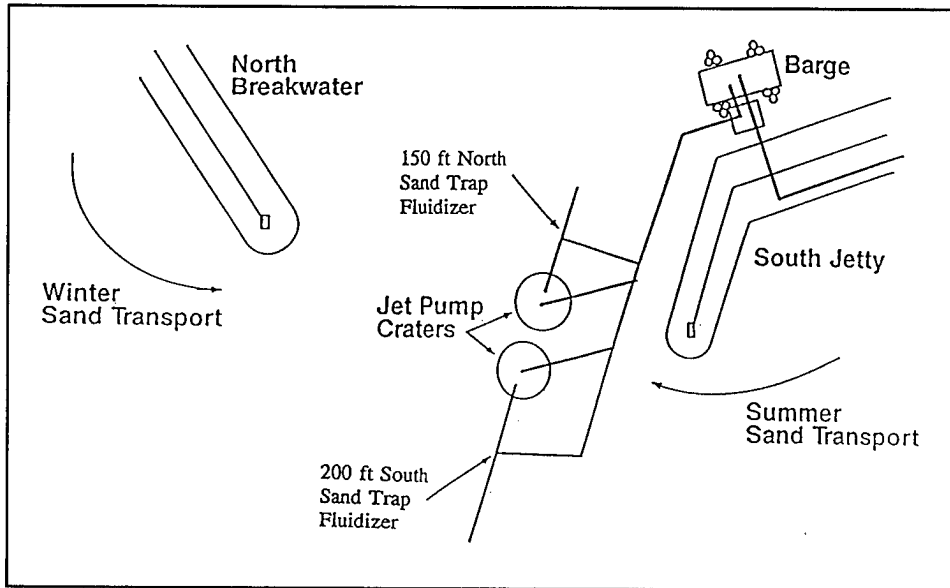

Figure B4. Phase II fluidizer locations (not to scale)

Table B3 Oceanside Sand Trap Fluidizer Hydraulic Design Data	
Fluidizer holes Diameter Spacing Orientation	1/8 in. 2 in. Horizontally opposed
Flow discharge General, per hole - per ft North sand trap fluidizer (150 ft) South sand trap fluidizer (200 ft)	1.5 gpm/hole - 18 gpm/ft 2,700 gpm 3,600 gpm
Pressure drop across the fluidizer orifice	65 ft
External pressure drop, general Assumed sand layer thickness above fluidizers	1 ft of water/ft of overburden 15 ft
Assumed pressure loss for piping between pump and fluidizers	85 ft
Total head required	165 ft

The Moffatt and Nichol 1990 design report also included other considerations not described here. These factors included: the increase in the thickness of the sand layer over the lower end of the fluidizer pipe; the increased flow at the upper end due to the increased head, the potential for hole enlargement due to corrosion or erosion, the potential for hole blockage, and calculations to determine how large the fluidization holes could become and still achieve fluidization for a given pump capacity.

Based on the head and flow requirements, pump capacity and horsepower were determined. Initially fluidizers up to 400 ft long had been considered with 1/8 in. holes every 2 in.; these fluidizers would require a flow of 7,400 gpm and 170 ft of head. Assuming 80 percent pump efficiency, the power required was approximately 400 hp. The existing supply pump used with the jet pumps was rated at 705 continuous hp (800 hp intermittent), and should have been capable of producing 9,800 gpm at 230 ft of head to the 400-ft fluidizer. Thus, the existing supply pump was expected to be adequate for the 200- and 150-ft-long fluidizers that were actually used. During Phase I it was found that the pump could not meet the specifications. During Phase II a new impeller was installed that should have achieved 7,000 gpm at 240 ft of head. However, the pump output was below these values and thus it was not possible to operate the north and south sand trap fluidizers simultaneously.

Both fluidizers use a centrally located feed pipe and are supplied through a common 16-in. diameter line. As noted previously, during Phase II a single supply pump provided water for both the fluidizers and jet pumps, but did not provide sufficient flow and head to operate both at the same time. Thus a valve is required to direct the flow to the appropriate device. After considerable study a butterfly valve was chosen for this application (Moffatt and Nichol, Engineers 1990; Patterson, Bisher, and Brodeen 1991). Reasons for selecting a butterfly valve include resilient seats, few moving parts, ease of installation and removal, and low cost. The valve is operated by a cylinder rack and pinion actuator that has all internal and moving parts sealed from the environment. Pneumatic actuation of the valve operator was selected because of an existing pneumatic system on the barge. Pneumatic operation also allows leak detection in the valve actuators and underwater tubing.

A variety of materials were considered for the sand trap fluidizer pipes including high density polyethylene (HDPE), normal carbon steel, 304 and 316 stainless steel, and two different alloys of copper-nickel and nickel-copper (Monel). Ultimately SDR 11 (160 psi rated) HDPE pipe (1990 estimated installed cost of \$349/linear ft) was selected due to its low cost and corrosion resistance. See Patterson, Bisher, and Brodeen (1991) and Moffatt and Nichol, Engineers (1990) for additional discussions on pipe material selection.

Because the fluidizer pipes could potentially be subject to wave-induced currents, the designers decided to support the pipe with piles. The piles also assisted in providing proper alignment both vertically and horizontally. Support piles were made of steel, 12 in. in diameter and driven 20 to 22 ft into the bottom. Pile spacing was approximately every 25 to 30 ft, with the upper end support located 1.5 ft from the end of the pipe and the lower end support located 4.5 ft from the end of the pipe. The support pile caps were steel plates (2 ft by 2.5 to 3 ft) to which the fluidizer pipes were bolted using "u" shaped clamps and stainless steel bolts (Figure B5). The full-length fluidizer pipes were constructed of a combination of butt welds and flanged connections to facilitate assembly under water. Three flanged sections were used for the 150-ft-long north sand trap fluidizer and four flanged sections were used for the 200-ft-long south sand trap fluidizer. The fluidizer pipes had pile supports at each of the flanged sections.

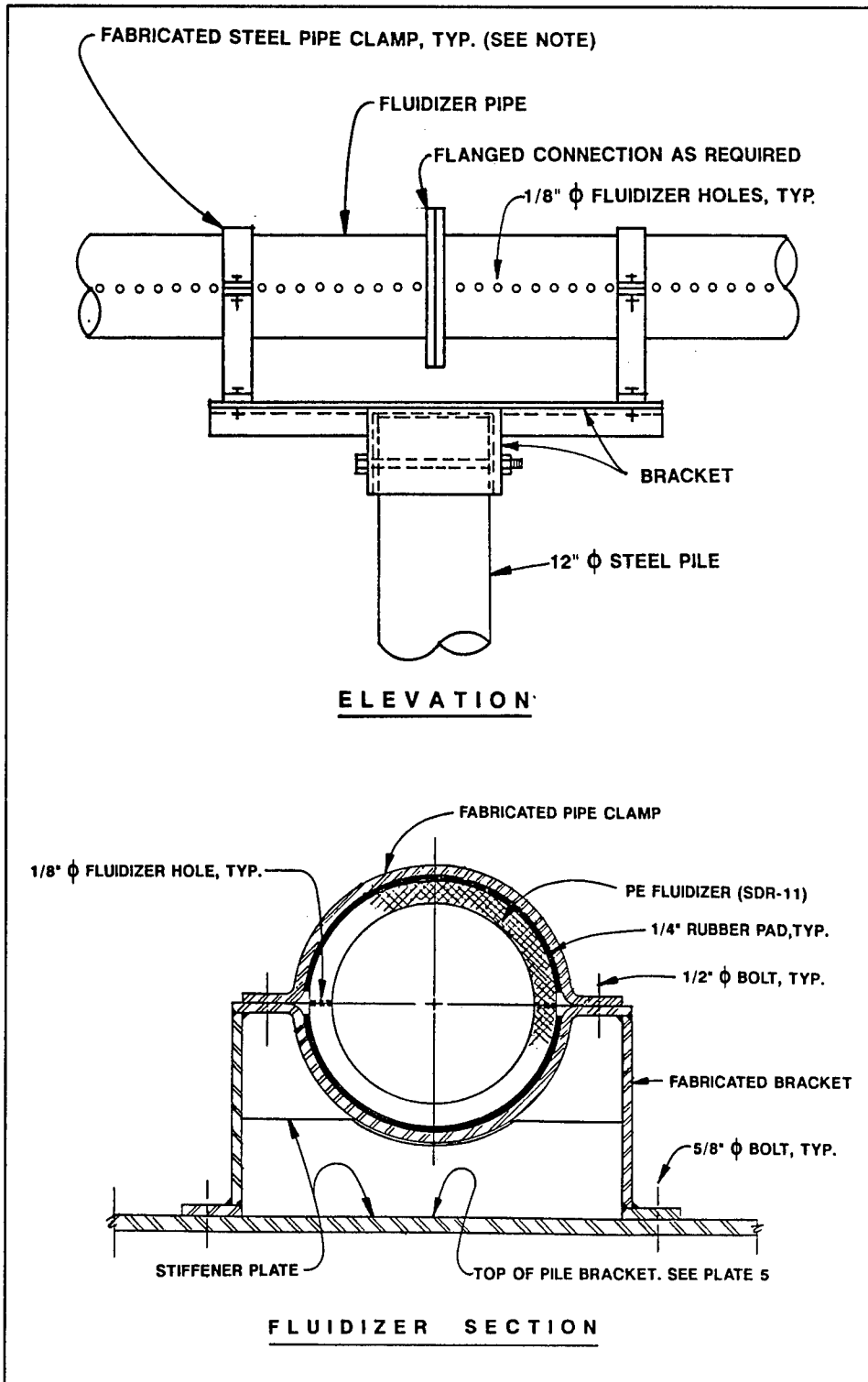

Figure B5. Clamps used to attach fluidizer pipes to support piles (Moffatt and Nichol 1990). Note: drawing is to illustrate concept, and should not be used for design

The lower ends of the fluidizers were located approximately 10 ft horizontally from the expected location of the jet pumps. Assuming the jet pumps would be located at a depth of 45 ft with crater side slopes of 1:1.5, the lower 17 ft of the fluidizer should have been exposed after the jet pumps had established the craters. Blind flanges were placed on the lower end of the fluidizers to allow divers to remove the flanges to clean out accumulated sand.

The designers expected the fluidizers to create trenches that varied depending on the depth of the entrance channel, crater side slopes, and the width of the crater at the bottom of the trench (Figure B6).

Phase II construction started in January 1991 and was completed in July 1991. Due to delays in awarding the operations contract, plant operations did not start until 22 November 1991. During this time the fluidizers were buried under up to 10 ft of sand. This large thickness of sand overburden caused problems both for the jet pumps and fluidizers. Sand migrated into the jet pumps. While the jet pumps could be started full of sand, this sand likely caused some additional wear. The fluidizers had considerable sand move into the pipes through the 1/8-in. fluidizer holes.

Problems with recovering the jet pumps during Phase I led to modifications to the deployment fluidizers. To keep the jet pump pipelines as far away as possible from the entrance channel, the jet pumps are attached to a 63-ft-long beam strongback that extends out from the pipe rack that runs parallel to the base of the south jetty (Figure B7). This strongback pivots from a support pile; the pivot point is located at a depth of 28 ft. This strongback also supports the supply and discharge lines. To allow the jet pumps to sink down to operating depth, 45 ft, fluidizer lines are included on the strongback. During Phase I, problems with deploying the jet pumps to their design depth and extreme problems with recovering the jet pumps resulted in expansion of the deployment fluidizers in Phase II to include a 4-in. fluidizer line on the top of the strongback with the fluidizer 1/8-in. holes spaced every 2 in. and pointed upward. The Phase I deployment fluidizer was a single 6-in. fluidizer placed on the bottom of the strongback with the more conventional horizontally directed holes (also 1/8-in. diameter on 2-in. centers) on both sides of the pipe.

Typical operating procedures

During Phase II normal operating procedures, the sand trap fluidizers were operated for approximately 30 minutes to empty any sand that had settled into the fluidizer trench since the previous day's operation. Then the supply pump was throttled back, clutch disengaged, and the valves were adjusted to allow water to flow to the jet pumps. The clutch was then engaged, and the supply pump was brought up to speed to operate the jet pumps.

After some trial and error, the operator found the best production generally resulted when jet pumps were operated for a period of 20 minutes following fluidizing. By this time the slurry specific gravity had usually fallen to about 1.05. At this point the procedures were reversed to allow another round of

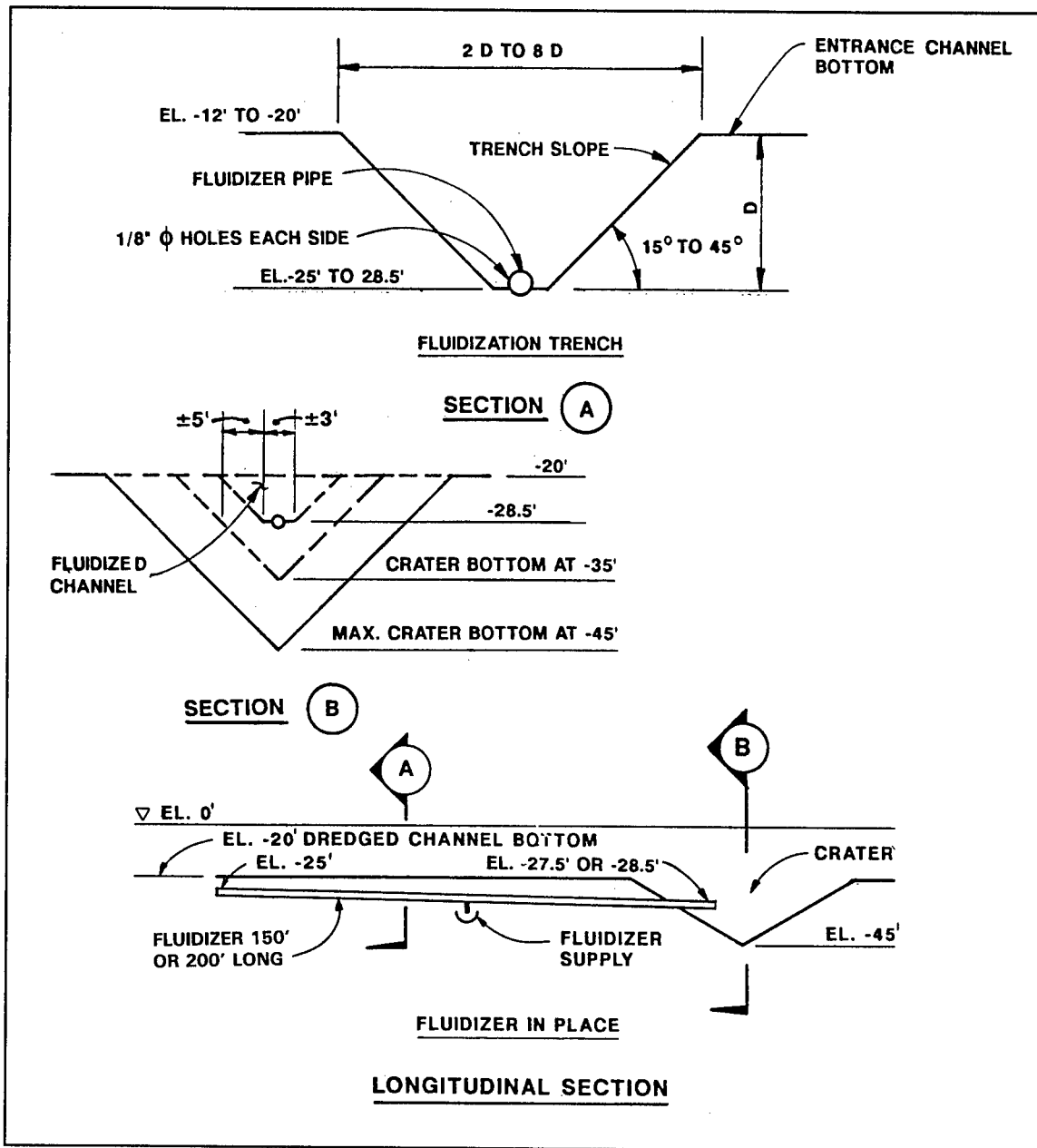

Figure B6. Projected fluidizer trench dimensions (Moffatt and Nichol 1990)

fluidization and followed by jet pump operation. This cycle was generally repeated several times until the sand supply was exhausted.

As noted earlier the lack of a separate fluidizer pump created the need to perform this constant switching back and forth between the fluidizers and jet pumps. Records indicate that on typical operating days only 50 percent or less of the total time available for bypassing could actually be spent bypassing sand, the remainder of the time was spent fluidizing, backflushing, and changing valve positions and engine speeds (Bisher and West 1993).

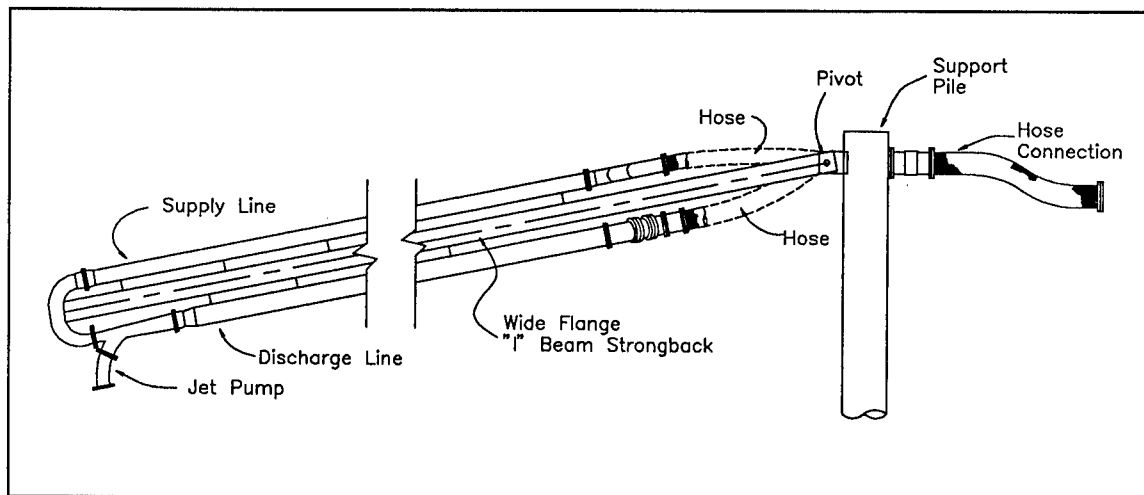

Figure B7. South jetty jet pump showing strongback and pivot point

Results of Phase II Operations

Production

Production during Phase II operations is summarized in Table B4. A total of over 106,000 yd³ were bypassed during the 13-month period from Dec 91 through Dec 92. While still considerably below the design target of 250,000 yd³ (though it was expected that it might require as many as 12 entrance channel jet pumps spread across the entrance channel to achieve this volume), the hourly average production rate, 95 yd³/hr was a 58 percent increase over the Phase I rate of 60 yd³/hr. The rate increase was thought to be primarily due to the fluidizers making additional sand available to the jet pumps. However, it is difficult to determine how much of the increase is due solely to the fluidizers because the rate of clogging, jet pump efficiency, etc., all impact overall production rate.

Actual fluidizer trench geometry

Actual fluidizer trench dimensions differed somewhat from predicted. Some (perhaps most) of the differences were likely due to the fact it was unlikely the fluidizers were ever completely free of clogs and that the jet pumps were fully operational during a time when bathymetry data were available. The best set of detailed bathymetric measurements were taken from 10 to 12 December 1991 when a series of four surveys on consecutive days were taken (two surveys were taken on one day). Figure B8 shows the layout of the fluidizers relative to the jet pumps and the position of a series of profile lines running parallel and perpendicular to the fluidizer directions.

Table B4 Oceanside Experimental Sand Bypass System - Phase II Production Summary (Bisher and West 1993)										
Date	Total Volume Pumped, yd ³	Pumping Sand Hours	Avg Transfer Rate, yd ³ /hr	Maximum Transfer Rate, yd ³ /hr	Fluidizing Hours			Backflush Hours	System Downtime and Maintenance Hours	
					NST ¹	SST ¹	NCD ¹			
Dec 91	3,400	35	97	²	6	6	6	27	67	
Jan 92	6,400	69	93	237	6	6	14	34	99	
Feb 92	4,200	36	115	²	3	3	6	17	98	
Mar 92	7,400	73	103	179	12	12	11	40	38	
Apr 92	9,400	101	92	168	9	8	14	21	37	
May 92	11,700	125	93	165	5	5	5	11	25	
Jun 92	11,500	126	91	152	4	9	5	6	41	
Jul 92	7,200	79	91	167	8	11	22	22	73	
Aug 92	8,200	87	94	156	9	9	11	29	15	
Sep 92	7,400	89	83	146	9	9	9	22	38	
Oct 92	8,900	97	91	155	10	10	10	24	33	
Nov 92	10,400	111	94	152	10	10	10	16	15	
Dec 92	10,600	99	108	179	8	11	11	29	28	
Total	107,000	1,128			98	107	133	296		

¹ NST - North sand trap fluidizer, SST - South sand trap fluidizer, NSD - North and South deployment fluidizer

² Data not available

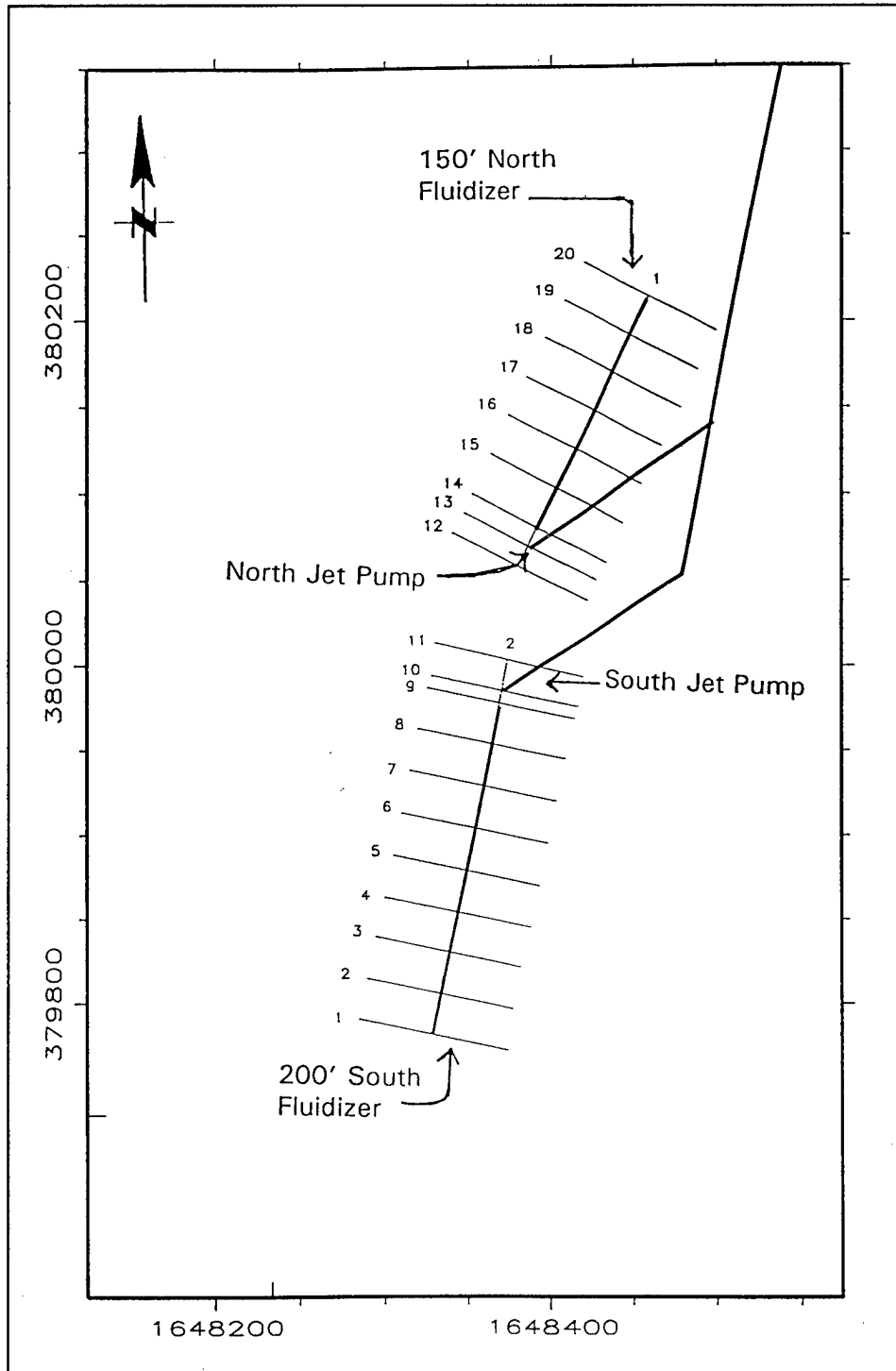

Figure B8. Fluidizers and cross-section locations

Figure B9 shows a profile along the axis of the north sand trap fluidizer. The outer 30 ft (left side of Figure B9) appears to be clogged. At least one other clog is evident along the inner 50 to 70 ft, though other profiles taken at different times show its location changes with time. Changes of up to 4 ft in elevation of sand above the north sand trap fluidizer due to fluidizer operation were evident. Also, it appears that the inner 12 ft of the fluidizer where it intersects the jet pump crater was exposed after the fluidizer operation.

Figure B10 shows the profile of the south sand trap fluidizer. Most of the outer 100 ft appears to be clogged. A second clog at about 50 ft from the inner end may be evident, though the jet pump crater is only 28 ft deep, and the apparent clog may simply be because there is no deep area for the fluidized sand to flow. After the last survey (number 4) the elevation of the sand above the fluidizer at a point approximately 130 ft from the outer end (90 ft on the figure axis) of the south sand trap fluidizer had decreased in elevation from 15.5 ft to 23.5 ft, a change of 8 ft, due to the intense fluidization between surveys.

Bathymetric cross sections perpendicular to the fluidizer show that the fluidizer creates a trench that generally widens from about 35 to 40 ft at the outer end and midsection to 60 to 70 ft wide at the lower ends, or the approximate width of the jet pump crater. Side slopes of the fluidizer trenches as measured after the last of the four surveys in Dec 91 and based on those cross sections where a definite trench was present ranged from 1V:6H to 1V:3H with an average of 1V:4H. Overall depth of the trench varied significantly, depending on the location of the clogs. In unclogged sections, the trench was up to 10 ft deeper than the surrounding depths.

Phase II Fluidizer Operating Problems

As noted earlier, the major operational problem with the fluidizers is sand that enters when the fluidizers are not working and cannot be removed. The six-month time period between the completion of Phase II construction and the start of operations allowed significant clogging to occur. In July 1992, the contractor operating the system for the Los Angeles District used a hydro-blast to clean out the fluidizers. The hydro-blast is a high pressure nozzle (operating at a pressure of 3,000 psi) on the end of a hose that is fed into the opened lower end of the fluidizer pipe by divers. The hydro-blast has both a piercing nozzle (jet is directed forward) and a back-flow nozzle that pushes debris back out of the pipe. Moffatt and Nichol designed a blind flange for the lower end of the fluidizer for this purpose. The contractor estimated he was able to remove a 30-ft-long sand plug in the lower end of the south sand trap fluidizer and 20-ft-long sand plug on the lower end of the north sand trap fluidizer. Also, the contractor was able to verify that the lower 98 ft of the north sand trap fluidizer and the lower 120 ft of the south sand trap fluidizer were clear. Apparently the flanged sections of the fluidizers had a lip that prevents hydro-blast from being able to travel the full length of the fluidizer.

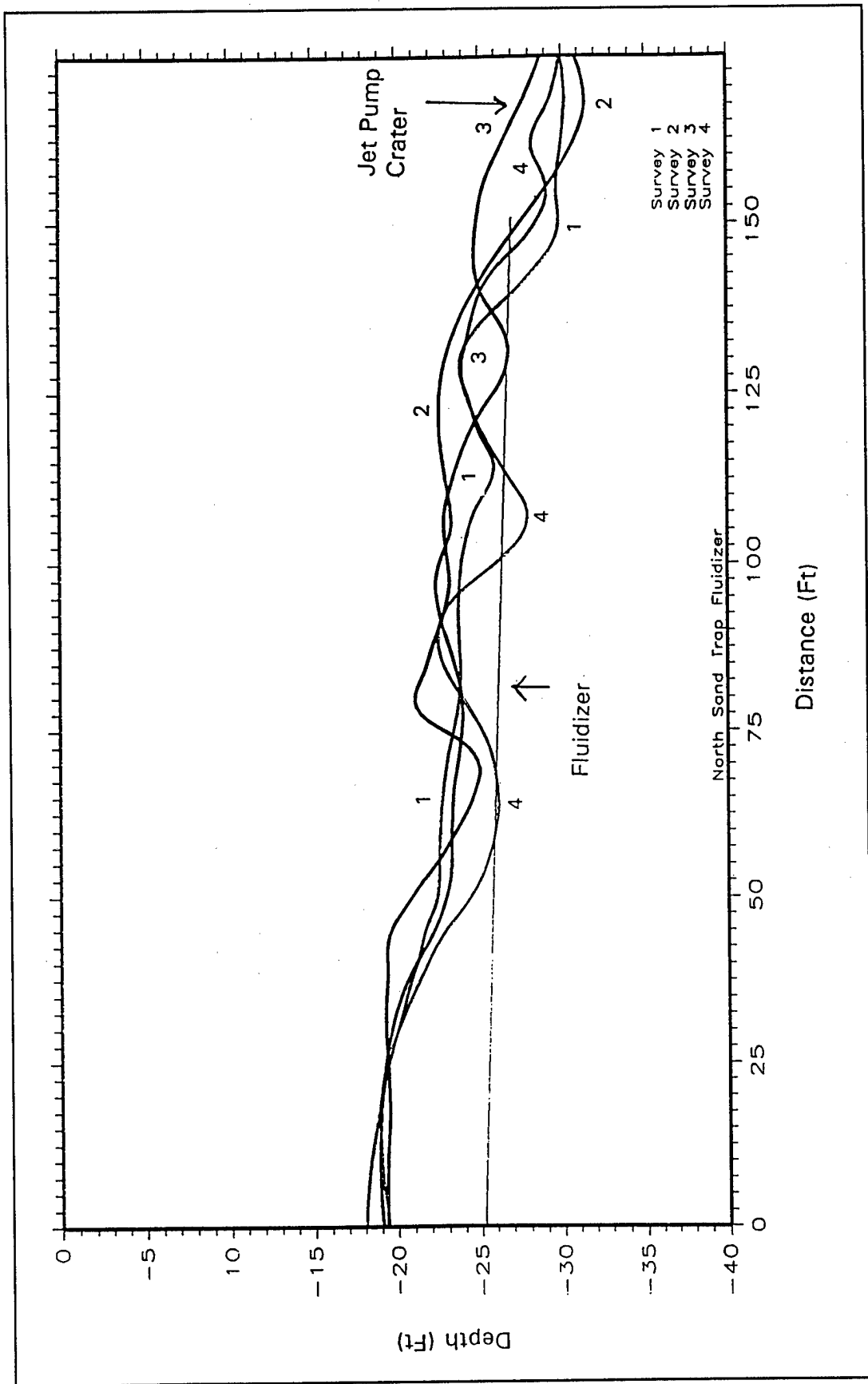

Figure B9. Bottom profile along the centerline of the north sand trap fluidizer, December 1991

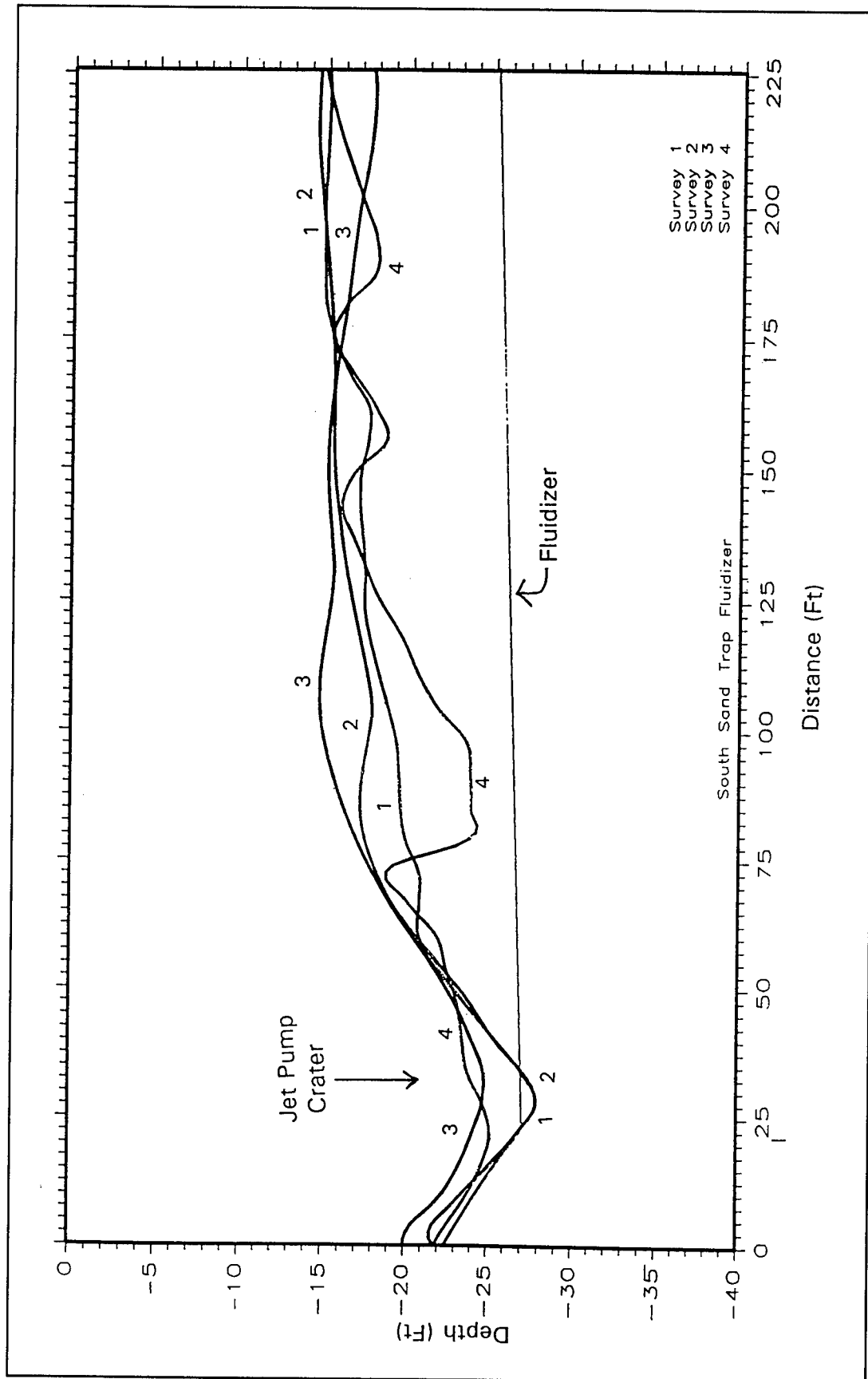

Figure B10. Bottom profile along the centerline of the south sand trap fluidizer, December 1991

The Phase II contractor also found debris left inside the north jet pump deployment fluidizer after Phase I construction and not removed during installation. These debris included welding rods and rocks.

Some of the holes in the jet pump deployment fluidizers (also made of HDPE), which operate whenever the jet pump is operating, had started to experience significant erosion.

The declogging efforts with the hydro-blast in July 1992 were also applied to the jet pumps. Apparently, the jet pump clogging problems were not in the jet pumps or pipelines leading to or from the jet pumps. Rather, debris contained in the sand of the jet pump craters, of which kelp is a prime component, prevented sand from freely entering the jet pumps during much of the time the system was operating.

Phase III - Planned Modifications

Major changes were planned for the final Phase III portion of the Oceanside Sand Bypass System. However, construction bids significantly exceeded cost estimates and available funds were insufficient to continue the experiment. Removal of the Oceanside Sand Bypass System is scheduled to occur in 1996. Still, the planned changes were expected to make a major improvement in system operation, and thus are worthy of discussion.

Moffatt and Nichol, Engineers (1994) describes the options considered and why the recommended option was selected. The following paragraphs summarize the major changes planned for Phase III, emphasizing modifications to the fluidizers.

The most significant Phase III change would have been the addition of two 200-ft-long fluidizers that would have fed sand from the tip of the south jetty to the original jet pump locations (Figure B11). It was hoped these fluidizers would capture sand that shoals off the tip of the south jetty, a location that has in the past seen an extreme amount of shoaling. Some of this material is thought to migrate into the harbor entrance along the base of the south jetty.

Placing an additional jet pump at the south jetty tip was considered. However, the cost and complexity of running separate supply and discharge lines to the jet pump combined with the difficulties of working in this exposed location caused that option to be eliminated.

The existing north sand trap fluidizer would have been lengthened an additional 145 ft during Phase III in an attempt to capture more of the sand that migrates along the base of the south jetty. The combined length of this fluidizer would have been 295 ft, requiring a second feed line to the new section of fluidizer.

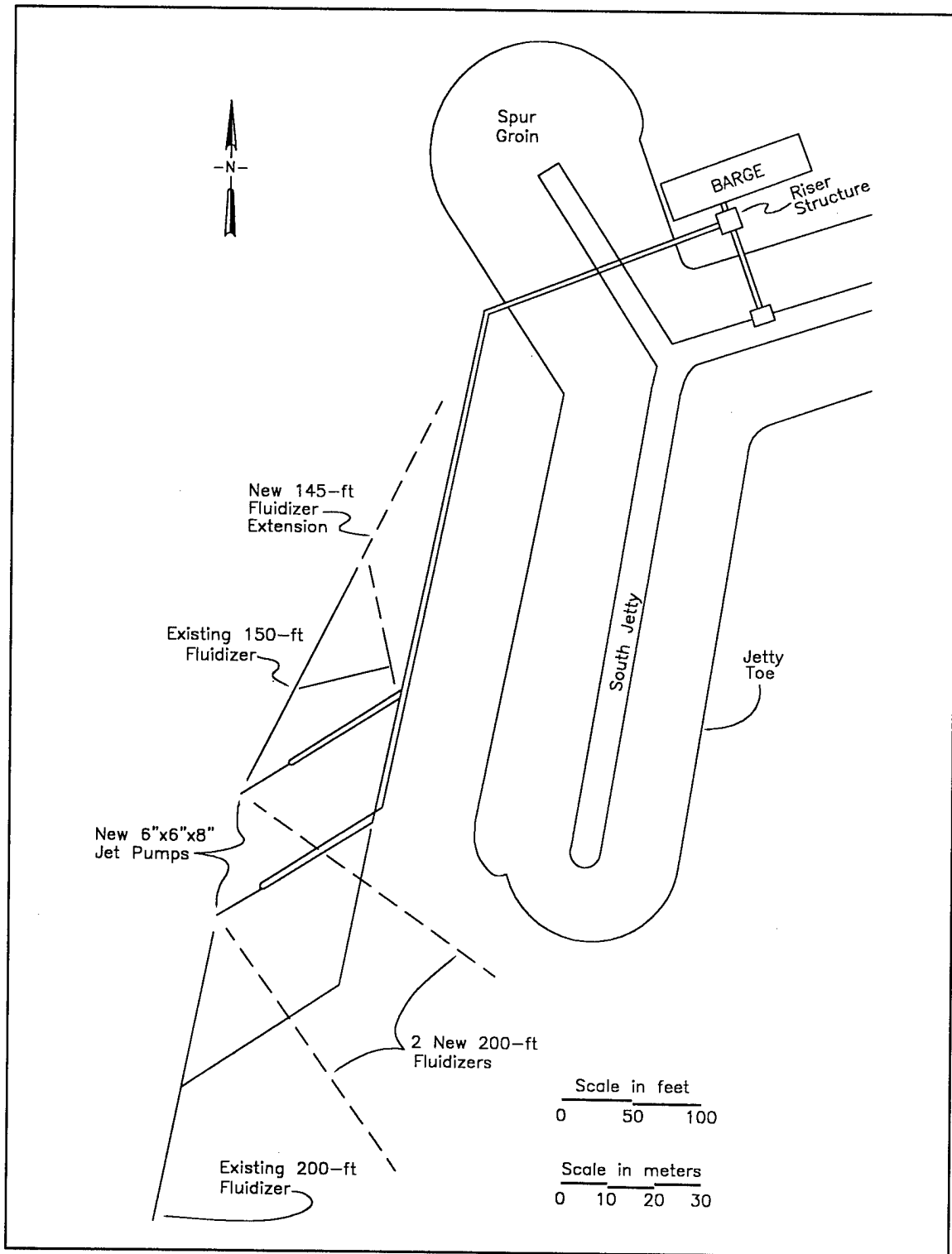

Figure B11. Planned modifications for Phase III of the Oceanside Sand Bypass System (after Moffatt and Nichol Engineers (1994))

A second major change for Phase III would have been the addition of a separate pump to power only the fluidizers, allowing simultaneous operation of the fluidizers and jet pumps. It was hoped that this would both increase production rate and overall volume bypassed.

Several Phase III changes would have been directed toward reducing the clogging of the fluidizers. The fluidizers would have been operated as much as possible, even if only at a minimum flow rate to maintain positive pressure in the pipe. This should have helped to avoid waves pumping sand into the holes, thereby reducing the risk of clogging. Drain holes, 1/2 in. in diameter spaced every 20 ft along the bottom of the fluidizers with a one-way ("duckbill") type valve attached, were being considered to help flush sand from the fluidizers during operations. It is likely that these one-way valves may have only been placed at the outer ends (40 to 60 ft) of the fluidizers. A manual bleed valve (diver operated) at the lower end of the fluidizers was also planned to allow sand to be flushed from the fluidizers without having to remove the blind flange.

Several changes to the jet pumps were also planned for Phase III. The 4-in. x 4-in. x 6-in. entrance channel jet pumps were to be replaced with 6-in. x 6-in. x 8-in. jet pumps to reduce clogging. These larger jet pumps would have been operated one at a time. A third mobile jet pump to remove sand from the fillet formed in front of the new stub groin was considered, but was eliminated to keep costs within budget.

The deployment fluidizers were to be replaced with a fixed fluidizer. The presence of the jet pump strongback and the relatively large number of associated pipes and hoses were thought to possibly interfere with the action of the deployment fluidizers which were used to allow the jet pump to sink into the sand. To prevent the jet pump from sinking too far into the sand, a stop, consisting of horizontal bar with vertical guides, was placed below the jet pump strongback about 13 ft back from the actual jet pump. The fixed fluidizer would have run from just below the strongback pivot point to a point just behind the actual jet pump. During jet pump deployment or retrieval, the fixed fluidizer would have fluidized the entire region above it including the sand surrounding the jet pump strongback.

Test sections of the sand trap fluidizers were to be removed, if the fluidizer holes showed significant erosion; then the existing sand trap fluidizers would have also been replaced.

REPORT DOCUMENTATION PAGE

Form Approved
OMB No. 0704-0188

Public reporting burden for this collection of information is estimated to average 1 hour per response, including the time for reviewing instructions, searching existing data sources, gathering and maintaining the data needed, and completing and reviewing the collection of information. Send comments regarding this burden estimate or any other aspect of this collection of information, including suggestions for reducing this burden, to Washington Headquarters Services, Directorate for Information Operations and Reports, 1215 Jefferson Davis Highway, Suite 1204, Arlington, VA 22202-4302, and to the Office of Management and Budget, Paperwork Reduction Project (0704-0188), Washington, DC 20503.

1.AGENCY USE ONLY (Leave blank)		2.REPORT DATE July 1996	3.REPORT TYPE AND DATES COVERED Final report	
4.TITLE AND SUBTITLE A Guide to the Planning and Hydraulic Design of Fluidizer Systems for Sand Management in the Coastal Environment			5.FUNDING NUMBERS Work Unit 32474	
6.AUTHOR(S) Richard N. Weisman, Gerard P. Lennon, James E. Clausner				
7.PERFORMING ORGANIZATION NAME(S) AND ADDRESS(ES) Imbt Hydraulics Laboratory, Fritz Engineering Laboratory, Lehigh University, Bethlehem, PA 18015; U.S. Army Engineer Waterways Experiment Station, 3909 Halls Ferry Road, Vicksburg, MS 39180-6199			8.PERFORMING ORGANIZATION REPORT NUMBER Technical Report DRP-96-3	
9.SPONSORING/MONITORING AGENCY NAME(S) AND ADDRESS(ES) U.S. Army Corps of Engineers Washington, DC 20314-1000			10.SPONSORING/MONITORING AGENCY REPORT NUMBER	
11.SUPPLEMENTARY NOTES Available from National Technical Information Service, 5285 Port Royal Road, Springfield, VA 22161.				
12a.DISTRIBUTION/AVAILABILITY STATEMENT Approved for public release; distribution is unlimited.			12b.DISTRIBUTION CODE	
13.ABSTRACT (Maximum 200 words) Fluidization is the process in which fluid is injected into a granular medium (typically sand) causing the grains to lift and separate. In the last decade, research has been conducted on the fluidization of sand at tidal inlets and harbor mouths with the intent to use fluidization for maintenance of navigable waterways and for sand bypassing. This report provides guidance in the design of fluidizer systems, including the fluidizer pipe, for use in channel maintenance and sand bypassing. The primary objective in the design of a fluidizer system is to create a trench of a given cross section and length. Complete fluidization must be achieved. The design must entail (a) the hydraulic aspect to attain full fluidization, and (b) a geometric element to obtain the desired trench geometry. Two design examples are given: one employs a fluidizer pipe to establish and maintain a navigable channel in a tidal inlet, and one involves the use of fluidizer pipe in conjunction with sand bypassing.				
14.SUBJECT TERMS Dredging Dredging Research Program Fluidization			15.NUMBER OF PAGES 94	
			16.PRICE CODE	
17.SECURITY CLASSIFICATION OF REPORT UNCLASSIFIED	18.SECURITY CLASSIFICATION OF THIS PAGE UNCLASSIFIED	19.SECURITY CLASSIFICATION OF ABSTRACT	20.LIMITATION OF ABSTRACT	