

NASA
Technical Memorandum 107227

Army Research Laboratory
Technical Report ARL-TR-1109

Experimental Evaluation of Face Gears for Aerospace Drive System Applications

Robert F. Handschuh and David G. Lewicki
Vehicle Propulsion Directorate
U.S. Army Research Laboratory
Lewis Research Center
Cleveland, Ohio

Gregory F. Heath
McDonnell Douglas Helicopter Company
Mesa, Arizona

Robert B. Bossler, Jr.
Hacienda Heights, California

Prepared for the
Seventh International Power Transmission and Gearing Conference
sponsored by the American Society of Mechanical Engineers
San Diego, California, October 6-9, 1996



National Aeronautics and
Space Administration

DTIC QUALITY INSPECTED 3



DISTRIBUTION STATEMENT A
Approved for public release;
Distribution Unlimited

19960926 138

DISCLAIMER NOTICE



THIS DOCUMENT IS BEST QUALITY AVAILABLE. THE COPY FURNISHED TO DTIC CONTAINED A SIGNIFICANT NUMBER OF PAGES WHICH DO NOT REPRODUCE LEGIBLY.

EXPERIMENTAL EVALUATION OF FACE GEARS FOR AEROSPACE DRIVE SYSTEM APPLICATIONS

Robert F. Handschuh
David G. Lewicki
Army Research Laboratory
NASA Lewis Research Center
Cleveland, Ohio

Gregory F. Heath
McDonnell Douglas Helicopter Company
Mesa, Arizona

Robert B. Bossler, Jr.
Private Consultant
Hacienda Heights, California

I. ABSTRACT

The experimental evaluation of face gears has been ongoing at NASA Lewis since 1991. Testing to date has focused on the feasibility of using this gear mesh to transfer power between intersecting shafts as found in helicopter main rotor transmissions. The focus of the experiments has been to determine the failure modes and load capacity of this gear mesh operated in a simulated helicopter transmission environment. At this time tests have been completed on a total of ten sets of face gears using a test facility located at NASA Lewis. Surface pitting was the predominant failure mode generated, however bending failures were also experienced. All tooth fractures due to pitting or bending occurred on the gear member. The spur gear pinion typically only had minor wear. Results from these tests indicated that the components would have to use aerospace gear materials and advanced manufacturing procedures to achieve the desired long component life.

II. INTRODUCTION

The transfer of power between intersecting axes can be accomplished in many ways (Dudley, 1984; Drago, 1988). In aerospace applications this function is normally accomplished using spiral bevel gears. The use of gears, in this very demanding high speed and load environment, requires that the surfaces be manufactured to the highest quality. Therefore the manufacture of gears used in this manner has also reached a high degree of sophistication due in part by the demands of the aerospace gear community. Currently full computer numerical controlled (CNC) machine tools and coordinate measurement machines (CMM) are used to manufacture and assess the finished surfaces in the production of spiral bevel gears.

The manufacture of the face gear, however, has not evolved to the current level of spiral bevel gears. Therefore less than optimal gear materials and processing of the component has been used. The current manufacture of this type of gear is achieved on a shaper-cutter, that has been used in some form for this type of gear for many decades. At the current time there is no dedicated machine tool available or CNC

machine that has had the proper software developed that can provide the same level of manufacture as that of spiral bevel gears.

Face gears can be configured in arrangements similar to that of spiral bevel or hypoid gears. Face gears can have shaft intersecting angles that differ from 90° and can have shaft centerline offset. The input gear can be a spur or helical gear, thereby offering the opportunity of many arrangements between the pinion and gear.

The use of face gears in advanced helicopter transmissions was proposed during the U.S. Army Advanced Rotorcraft Transmission Program (Bossler and Heath, 1990; Bill, 1990; and Heath, 1993) and by other researchers from Europe (Hermens and Verschuren, 1989). The arrangement developed under the U.S. Army project is shown in Fig. 1. The use of face gears, as shown in Fig. 1, has the input spur gear pinion driving two face gears. This arrangement would lower the tooth load of the input gear by approximately one-half, assuming that the load was equally split between the two output gears. This design had a very drastic effect on reducing the drive system weight of the proposed transmission. This advantage is of the highest importance in aerospace drive systems.

An initial experimental evaluation of this concept, using four sets of face gears was performed (Handschuh, et al., 1994). Face gears were tested at NASA Lewis. The purpose of these tests was to demonstrate that face gears could be used at high rotational speeds and carry high loads, similar to what would be expected if used in a helicopter main rotor drive system. The tests showed that this concept was feasible for aerospace applications. The predominate problem was surface pitting of the face gear member that then, in one of the two tests, led to a tooth fracture.

The objective of the work to be discussed in this paper is to extend what was presented in the earlier experimental evaluation. The effort to be described in this report was to look at possible manufacturing alternatives to grinding of the components. A total of six more sets of face gears were tested at the same high speeds and loads. These six sets of gears were manufactured in three different configurations. Two sets were manufactured as those in the prior tests. Two sets were manufactured with a slightly different geometry on the gear member. The final

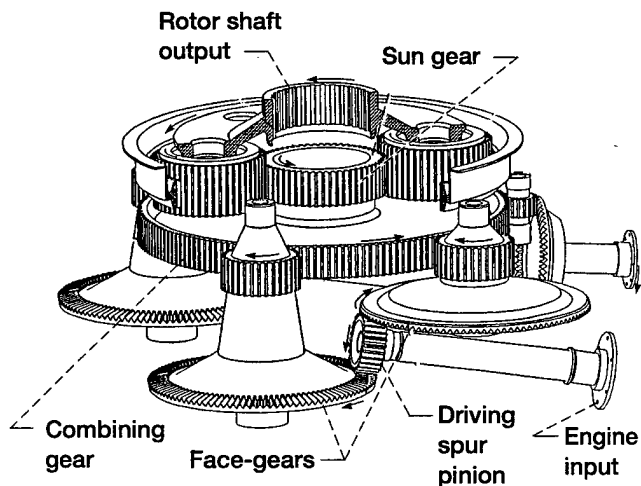

Figure 1.—Helicopter transmission with face gear drives.

two sets were manufactured with the original geometry but with a different heat treatment. All test specimens were tested in a similar manner whereby the test was conducted until tooth fracture occurred. Test hardware that had failed was replaced by new hardware and the testing continued. This paper contains a summary of all of the results of tests conducted at this time.

III. FACE GEAR GEOMETRY

Face gear terminology is depicted in Fig. 2. A spur gear pinion meshes with the face gear in the arrangement tested herein. The face gear has a radially varying geometry, where the limits are undercutting at the inner radius and tooth pointing at the outer radius (Dudley, 1984). Axial location of the spur pinion is not critical, as in spiral bevel gears, and the pinions are typically made with a wider face width for bending strength improvement. Axial location of the gear is used to achieve the required backlash.

Research on this type of gear mesh, in comparison to other types, has been rather limited. Bloomfield (1947), Francis and Silvagi (1967), Chakraborty and Bhadoria (1971, 1973, and 1975) provide the basics in the design of face gears as described in this report as well as those that are designed for offset geometry. Not until the recent interest sparked by the use of this component in aerospace gearing has further investigation of this component been reported in the open literature. Recent research has focused on gear geometry (Litvin et al., 1992; and Litvin, 1994), design to refine our understanding of the components that are manufactured, and possible application of this type of gear mesh to other aerospace transmission systems (Litvin et al., 1994a; Litvin et al., 1994b; Chen and Bossler, 1995; and Basstein, and Sijistra, 1993). Efforts in these areas are a necessary part of the research effort that must be done to implement this type of gear mesh into the aerospace gear industry.

IV. TEST APPARATUS AND TEST HARDWARE

The test facility used to conduct the tests described in this report is the spiral bevel test rig described in Handschuh et al. (1994). The facility operates in a closed-loop arrangement where the drive motor only needs to provide the power to overcome the system losses. An overall

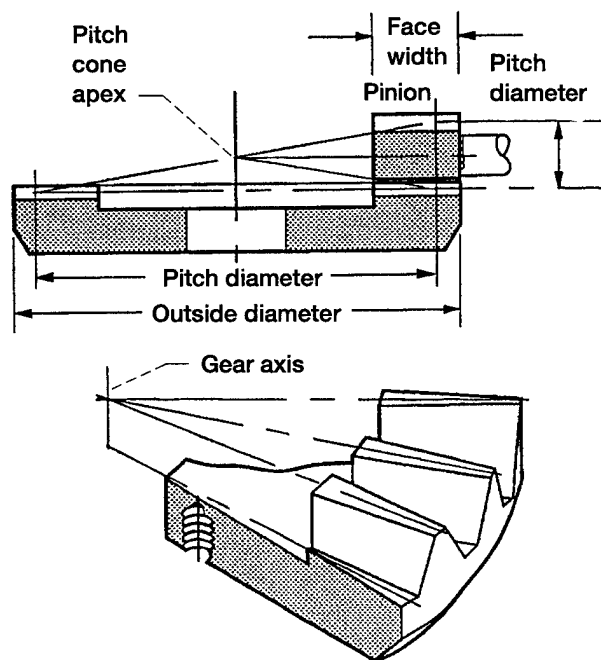

Figure 2.—Face gear terminology.

sketch of the facility is shown in Fig. 3(a) and the facility in the face gear arrangement is shown in Fig. 3(b). Rotational motion is provided through V-belts connecting one of the helical gear shafts to the drive motor. The helical gears complete the closed loop. A thrust piston that moves one of the helical gears axially is used to change the loop load during operation. A torque meter measured the loop torque.

Two sets of face gears are tested simultaneously. The left side (test section in Fig. 3(b), operates in the speed reducer mode as would be used in a helicopter main rotor transmission application. The right side (slave section) operates in a speed increaser mode, where the gear drives the pinion. The two pinions are connected via a cross-shaft. A detailed explanation of the operation of the test stand can be found in Handschuh (1992), Handschuh and Kicher (1995); and Handschuh (1995).

The face gears were designed to one-half size (one-eighth power) of the configuration reported in Heath and Bossler (1993) and to fit within the facility constraints. The face gear design parameters are shown in Table I and a photograph of the test hardware is shown in Fig. 4. The calculated values for bending and contact stress index were found by analyzing the gear mesh as a set of spur gears.

The pinions were manufactured using high-quality aerospace practices where the pinion surfaces were nitrided and ground. As already mentioned the face gear members had differences among the ten sets tested. The baseline gears were manufactured with a 29 tooth shaper-cutter. More teeth on the shaper than the actual pinion generates a gear surface with a slight amount of crowning. The baseline face gears were also through-hardened. The second type of face gears tested was the same as the baseline (same geometry) except the gears were nitrided. The final type of face gears were generated with a 28 tooth shaper-cutter and through-hardened. All face gears were made from a maraging steel that has a high tolerance to heat treat distortion as there was no further finishing (i.e., grinding) after heat treatment.

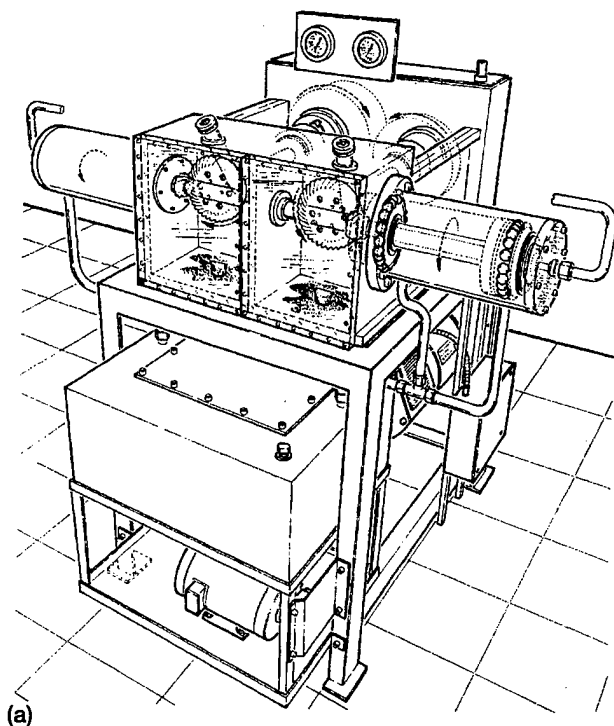

(a)

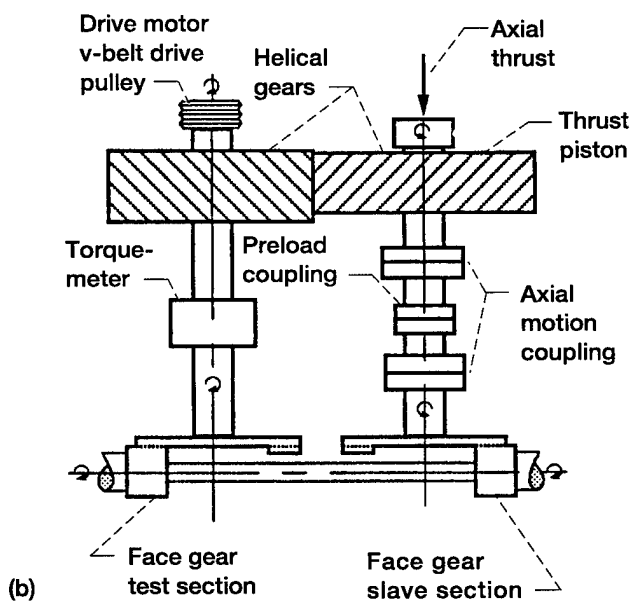

Figure 3.—Facility for face gear test. (a) Spiral bevel gear configuration. (b) Facility layout in gear configuration.

Table I.—Face Gear Design Data

AGMA quality	12
Number of teeth pinion, gear	28,107
Diametral pitch	16
Pressure angle, deg	25.0
Shaft angle, deg	90.0
Face width, mm (in.), of—	
Pinion	37.6 (1.285)
Gear	15.5 (0.62)
RMS surface finish, μm ($\mu\text{-in.}$)	0.51 (20)
AGMA pinion bending stress index, MPa (ksi)	248 (36)
AGMA pinion contact stress index, MPa (ksi)	1034 (150)
AGMA material	Maraging 300 steel ^a

^aPer AMS 6514.

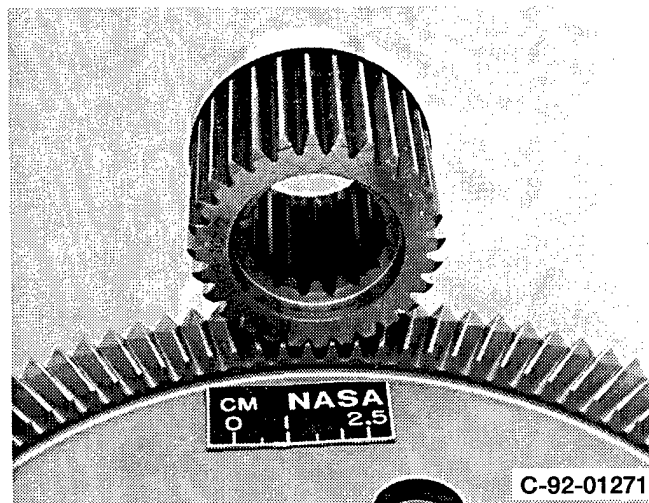

Figure 4.—Photograph of face gear specimen used in test program.

As mentioned earlier the axial positioning of the pinion with respect to the gear is not critical as it is in a spiral bevel gear mesh. The pinion was positioned to facilitate proper connection to the rest of the test facility. The gear member was adjusted axially via shims to provide the backlash of 0.05 to 0.10 mm (0.002 to 0.004 in.). The contact pattern at light load was also checked in a manner as used for spiral bevel gears. A photograph of the contact pattern is shown in Fig. 5.

More details of the basic design strategy used for this particular gear mesh can be found in Handschuh et al. (1994).

V. EXPERIMENTAL PROCEDURE

In the earlier test performed in this facility (Handschuh, Lewicki, and Bossler, 1994), part of the procedure involved slowly increasing speed and torque until full conditions were achieved. This was done in a deliberate fashion due to the unknown operational characteristics of this gear mesh at high speed and load. For all tests, in this study, the break-in of the test gears occurred at low speed and torque for at least 0.21 million pinion cycles or 0.056 million gear cycles. The break-in portion of the tests occurred for at least two levels of speed (approximately 1000 and 1760 rpm; gear speed) and two levels of torque (approximately 65.5 N*m (580 in.*lb) and 128.2 N*m (1135 in.*lb); gear torque).

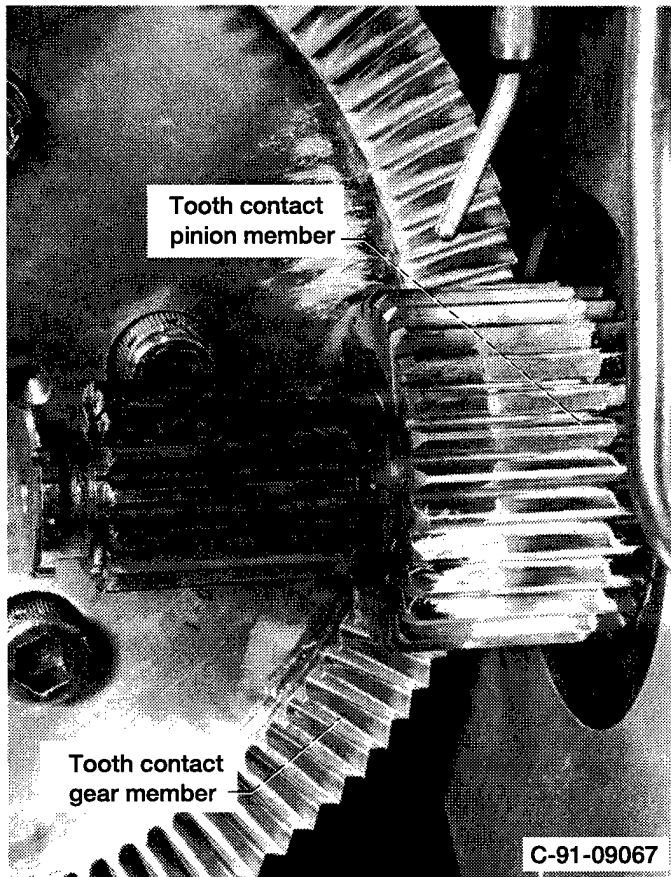

Figure 5.—Photograph showing contact pattern using red lead.

After the break-in the test hardware was then operated at 100 percent speed and load conditions for at least 30 million pinion cycles. If the test hardware achieved the 30 million pinion cycles at 100 percent load and speed, then the load was increased and testing was continued until tooth fracture in some form occurred. Some face gear tests were suspended after the predetermined level of cycles at load had been reached. The maximum torque applied during any test was 200 percent of the design level. All other system parameters were held constant as shown in Table II.

VI. RESULTS AND DISCUSSION

The results found from all ten face gear tests will now be discussed. The data will be presented in a tabular form to show how the various test hardware was installed, tested, and what the fracture mode was for that particular test. Then photographs of some of the test hardware will also be presented to show the types of failure/fracture modes that occurred.

The entire testing program conducted to date and the specimen used in those tests are shown in Table III. Tests are shown in the order that they were conducted. In tests 1 to 3 and 5, new sets of pinions and face gears were installed in both sides of the facility at the start of the tests. In tests 4 and 6, new face gears were installed in the test section at the start of the tests. For test 4, the face gears from test 3 were used in the slave section. For test 6, the face gears from test 5 were used in the slave

Table II.—Test Facility Operational Parameters

Pinion shaft speed (100 percent) rpm	19,110
Pinion torque (100 percent), N·m (in.·lb)	67.8 (600)
Nominal lubricant flow rate cm/s (gpm)/mesh	51 (0.8)
Lubricant oil inlet temperatures, °C (°F)	74 (165)
Lubricant jet pressure, MPa (psi)	0.552 (80)

section. For test 7, the face gears from test 6 were used in the test section and the face gear from test 4 was used in the slave section. In test 8, previously tested hardware from test 7 was used. Also listed in Table III is the component that failed.

In Table III the number of cycles that a given gear set successfully completed for a given test is shown. The data shows that only one set failed to at least complete the 100 percent speed and load portion of the test (slave section gear set "D", baseline). Of the specimens tested to 200 percent torque and 100 percent speed, three sets made it to 30 million pinion cycles without tooth fracture. Others completed some or most of the 30 million pinion cycles at 200 percent load (7.9 million gear cycles) before a pitting or bending initiated fracture occurred. One of the nitrided gear sets, set "H", was used in four of the tests and collected a total of 168 million pinion cycles at 100 percent load and speed as well as successfully completing the 200 percent load test. In this case the pinion had more surface related damage than the gear.

Pitting that led to tooth fracture was the predominant failure mode that was found during the tests conducted. However bending failures occurred in one case without any pitting initiated fractures and in two cases pitting and bending fractures occurred on the same component. A summary of each face gear set, type of fracture, and the total cycles operated are contained in Table IV.

Photographs of the different test hardware failure modes and post-test condition will now be presented. In Fig. 6 gear set "E", a baseline gear set, is shown in the post-test condition. Pitting damage is shown but the two teeth that failed were bending initiated.

Figure 7 shows a typical pitting initiated tooth fracture (gear set "G"). A large pit developed on one of the teeth to a size large enough to cause the fracture of the tooth as shown in Fig. 7(b). This type of failure was the predominant one found in the study conducted herein.

In Fig. 8 the pinion from gear set "A" after testing is shown. The contact location on the pinion is evident from the slight polishing of the surface, however no damage to the surface occurred. This type of pinion condition was typical for all the tests conducted.

Figure 9 shows the pinion from gear set "H" after the completion of all tests. As mentioned earlier in this section of the report, this particular gear set accumulated the greatest amount of run time (168 million cycles at 100 percent load, 30 million cycles at 200 percent load). The contacting region between the pinion and gear are clearly indicated. Micropitting has occurred at various regions over the surface with a large concentration occurring at the region that meshes at the inner diameter of the gear member.

Figures 10 and 11 are photographs taken of a tooth from the failed gear set "J" in a scanning electron microscope. Both figures were taken of the tooth that failed in bending. Figure 10 shows a close-up of the contacting region micropitting. This type of surface damage was found in various stages on all gear members tested in this study. Figure 11 is a photograph of the fracture surface.

Table III.—Face Gear Testing Program, Load Cycles, and Test Result

Test number	Test section gear set, type	Slave section gear set, type	Gear cycles (million) at percent load		Test result
			100	200	
1	A, Baseline	B, Baseline	7.9	8.0	No tooth fracture
2	C, Baseline	D, Baseline	8.2	3.1	One tooth fracture on slave gear due to pitting
3	G, Nitrided	H, Nitrided	4.3	--	One tooth fracture on test gear due to pitting
4	E, Baseline	H, Nitrided	8.3	8.0	Two teeth fractured on test gear due to bending
5	I, Modified Geometry	J, Modified Geometry	8.3	5.5	Three teeth fractured on test gear, two pitting, one bending
6	F, Baseline	J, Modified Geometry	3.8	--	Two teeth fractured on slave gear, one pitting, one bending
7	F, Baseline	H, Nitrided	4.2	--	One tooth fracture on test gear due to pitting
8	F, Baseline	H, Nitrided	27.3	--	One tooth fracture on test gear due to pitting, different tooth than test 7

(7.9 million gear cycles = 30 million pinion cycles).

Table IV.—Testing Results For Each Face Gear Set

Gear set number, type, rig location	Gear cycles (million), percent load		Fracture mode (number of teeth)
	100 percent	200 percent	
A, baseline, test side	7.9	8.0	No fracture
B, baseline, slave side	7.9	8.0	No fracture
C, baseline, test side	8.2	3.1	No fracture
D, baseline, slave side	8.2	3.1	Pitting, (1)
E, baseline, test side	8.3	8.0	Bending, (2)
F, baseline, test side	35.3	--	Pitting, (1) at 4.3 million cycles, and pitting, (1) 35.3 million cycles
G, nitrided, test side	4.3	--	Pitting, (1)
H, nitrided, slave side	44.1	8.0	No fracture
I, mod. geom., test side	8.3	5.5	Pitting, (2), and bending (1)
J, mod. geom. slave side	12.1	5.5	Pitting, (1), and bending (1)

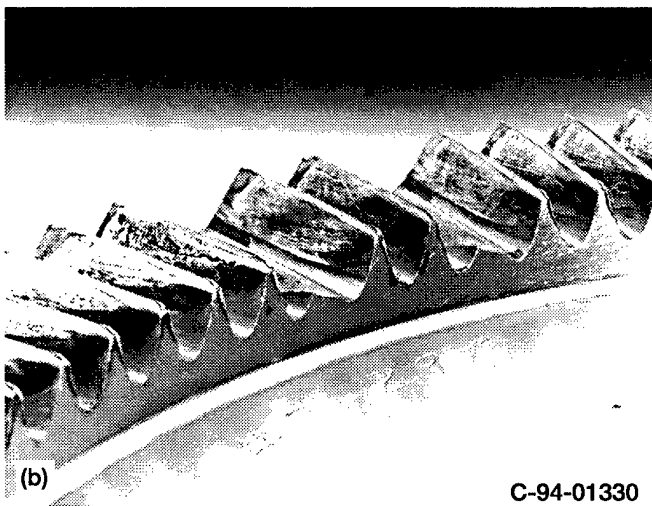
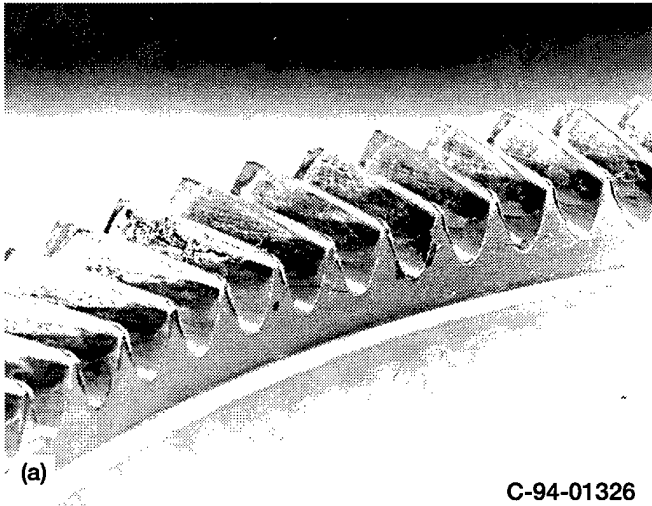

Figure 6.—Bending fractures of face gear teeth, test specimen set "E" (baseline). (a) Failed teeth set in place. (b) Failed teeth removed

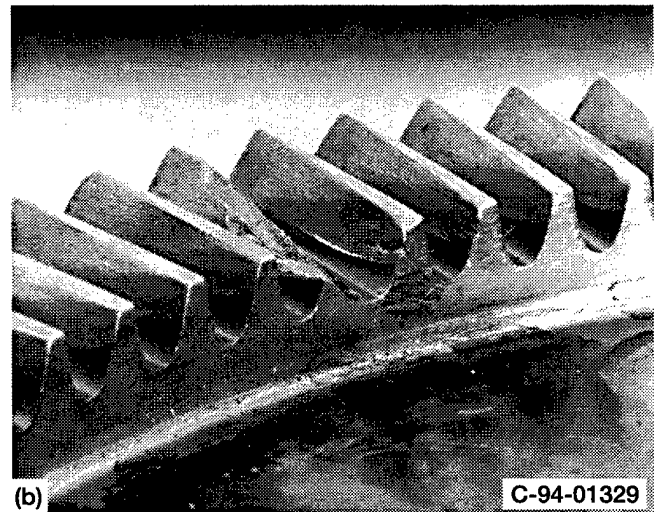
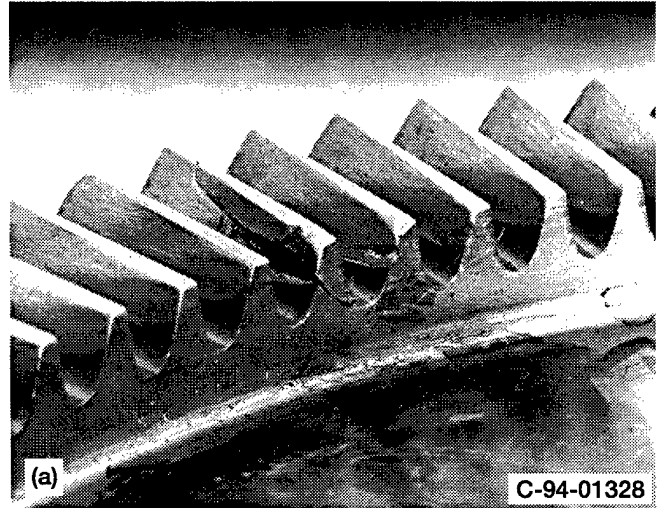

Figure 7.— Pitting initiated failure that led to tooth fracture from face gear set "G". (a) Failed tooth in place. (b) Failed tooth removed.



Figure 8.—Pinion from face gear set "A" after 30 million cycles at 100% load and 30 million cycles at 200 % load.

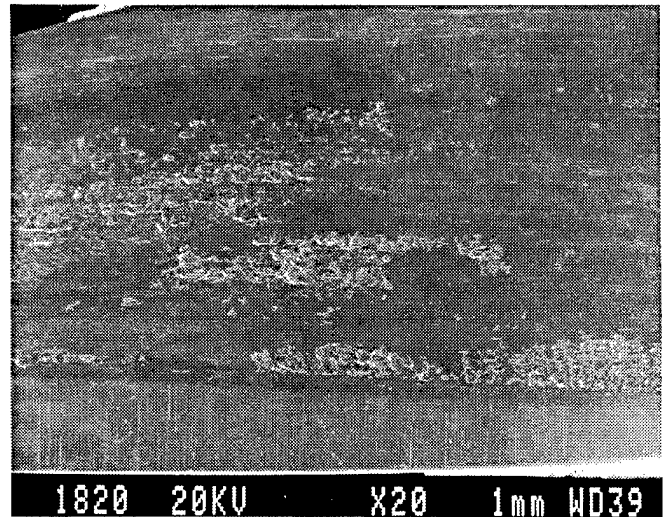

Figure 10.—Pitting damage typically found during testing. (set "J").

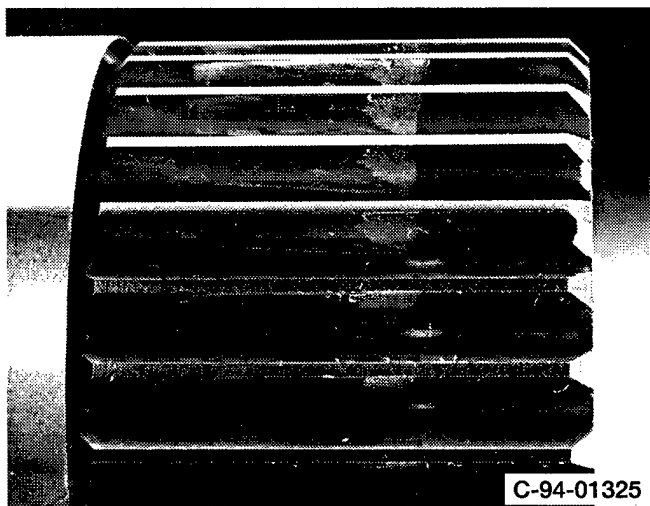

Figure 9.—Pinion from face gear set "H" (nitrided) after 168 million cycles at 100% load and 30 million cycles at 200% load.

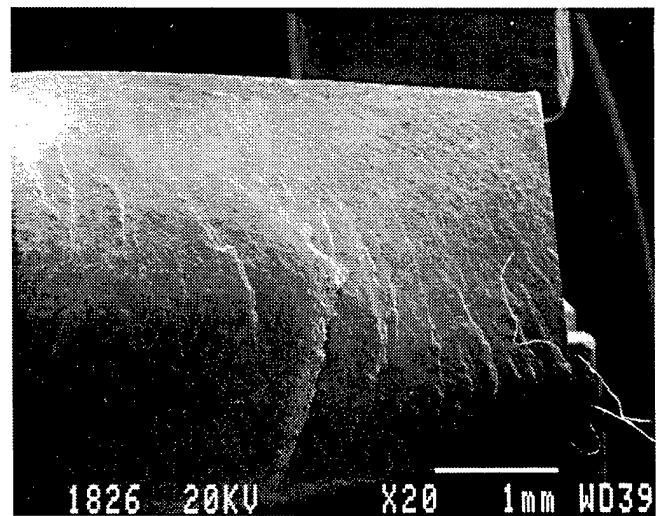

Figure 11.—Photograph of bending failed tooth fracture surface. (set "J").

The results found during this test program have been inconsistent. Two modifications to the baseline arrangement, nitriding and modified geometry, did not lead to an obviously improved arrangement. Nitriding the gear member to improve surface hardness provided one very durable gear set and one set that failed after only completing half of the 100 percent load test. The modified geometry gear sets produced results that were similar to the baseline hardware. Neither modification could point to a clear cut improvement.

All face gears tested experienced micropitting in some form. In the tests conducted herein operation was not stopped due to micropitting even though many researchers/designers would consider this as a surface failure. Letting the damage progress, lead to pitting initiated tooth fracture. However, as the test results indicate, three of the ten face gear sets experienced bending failures as well.

As the tabular and photographic data indicate, face gears are a viable option for high speed and load designs such as found in helicopters. Currently the manufacturing art of this component needs to be improved to have the gear member made to the level that is found for aerospace spiral bevel gears. Improved manufacturing, heat treatment, and materials for use in this type of gear component will permit operation at aerospace conditions with long life.

VII. CONCLUSIONS

A total of ten face gear sets, in three different configurations, were tested in an aerospace gearbox environment. The operational capability and failure mode of the face gear system was the intent of this study. Based on the results attained the following conclusions can be reached:

1. Face gears have demonstrated the capability to operate successfully at high speed and load in an aerospace environment where spiral bevel gears are currently used exclusively.

2. All face gear specimens successfully completed, with varying degrees of surface distress, the 100 percent load and speed tests with the exception of one set that failed at a point only half way through the 100 percent load test.

3. Four of the ten total gear sets successfully completed the overload test to 200 percent of the full load and reached 30 million pinion cycles.

4. One gear set that was nitrided was used in multiple tests and had accumulated over 168 million pinion cycles at 100 percent load and over 30 million pinion cycles at 200 percent load. In this gear set the pinion member had the greater surface damage at the end of the tests.

5. This study has further confirmed that a machine system to grind face gears will be required to have successful application in aerospace systems.

VIII. REFERENCES

Basstein, G., and Sijistra, A.: New Developments in Design, Manufacturing, and Applications of Cylkro-(Face) Gears. 1993 American Gear Manufacturers Association Fall Technical Meeting, Paper 93FTM7.

Bill, R.: Advanced Rotorcraft Transmission Program, NASA TM-103276, 1990.

Bloomfield, B.: Designing Face Gears. *Mach. Des.*, vol. 19, no. 4, Apr. 1947, pp.129-134.

Bossler, R. and Heath, G.: Advanced Rotorcraft Transmission (ART) Program Status. Rotary Wing Propulsion Specialists Meeting, 1990; Proceedings of the American Helicopter Society, Alexandria, VA, 1990, Paper #4.

Chakraborty, J. and Bhadoria, B.: Design Parameters for Face Gears. *J. Mechanisms*, vol. 6, pp. 435-445, Pergamon Press, 1971.

Chakraborty, J. and Bhadoria, B.: Some Studies on Hypoid Face Gears. *Mechanisms and Machine Theory*, vol. 8, pp. 339-349, Pergamon Press, 1973.

Chakraborty, J. and Bhadoria, B.: Surface Durability Ratings for On-Center and Off-Set Spur Face Gears, ASME Paper 75-PTG-4, 1975.

Chen, D. and Bossler, R.: Design, Analysis, and Testing Methods for a Split-Torque Face-Gear Transmission. AIAA 95-3051, 1995.

Dudley, D.: *Handbook of Practical Gear Design*, McGraw-Hill, 1984.

Drago, R.: *Fundamentals of Gear Design*, Butterworth Publishers, 1988.

Francis, V. and Silvagi, J.: Face Gear Design Factors. *Gear Design and Application*, N.P. Chironis, ed., McGraw Hill, 1967, pp. 87-91.

Handschuh, R.: Effect of Lubricant Jet Location on Spiral Bevel Gear Operating Temperature. NASA TM-105656, AVSCOM TR 91-C-033, Sept., 1992.

Handschuh, R.: Thermal Behavior of Spiral Bevel Gears. NASA TM-106518, ARL-TR-403, Jan., 1995.

Handschuh, R., and Kicher, T.: Experimental and Analytical Assessment of the Thermal Behavior of Spiral Bevel Gears. Proc. of 1995 American Gear Manufacturers Association Fall Tech. Meeting, Paper 95FTM7, Oct. 1995.

Handschuh, R., Lewicki, D., and Bossler, R.: Experimental Testing of Prototype Face Gears for Helicopter Transmissions, Proc. Instn. Mech. Engrs., Vol. 208, pp. 129-136, Oct., 1994.

Heath, G., Bossler, R.: Advanced Rotorcraft Transmission (ART) Program—Final Report, NASA CR-191057, 1993.

Hermens, E. and Verschuren, N.: New Transmission Components for Helicopter Applications. Paper #32, Presented at the European Rotorcraft Forum, 15th, Sept. 12-15, 1989, Amsterdam, Netherlands.

Litvin, F.: *Gear Geometry and Applied Theory*. Prentice Hall, 1994.

Litvin, F., Chen, N., Hsiao, C., Bossler, R., and Heath, G.: Design, Manufacture, and Application of Face-Gear Drives in Helicopter Transmissions. Proceedings of 1994 International Gearing Conference, Newcastle upon Tyne, England, pp. 427-432.

Litvin, F., Wang, J., Bossler, R., Chen, D., Heath, G., Lewicki, D.: Application of Face-Gear Drives in Helicopter Transmissions. *J. of Mechanical Design*, vol. 116, no. 3, pp. 672-676, Sept., 1994.

Litvin, F., Zhang, Y., Wang, J., Bossler, R., and Chen, Y.: Design and Geometry of Face-Gear Drives, *J. of Mechanical Design*, vol. 114, pp. 642-647, Dec. 1992.

REPORT DOCUMENTATION PAGE

Form Approved
OMB No. 0704-0188

Public reporting burden for this collection of information is estimated to average 1 hour per response, including the time for reviewing instructions, searching existing data sources, gathering and maintaining the data needed, and completing and reviewing the collection of information. Send comments regarding this burden estimate or any other aspect of this collection of information, including suggestions for reducing this burden, to Washington Headquarters Services, Directorate for Information Operations and Reports, 1215 Jefferson Davis Highway, Suite 1204, Arlington, VA 22202-4302, and to the Office of Management and Budget, Paperwork Reduction Project (0704-0188), Washington, DC 20503.

1. AGENCY USE ONLY (Leave blank)		2. REPORT DATE September 1996	3. REPORT TYPE AND DATES COVERED Technical Memorandum	
4. TITLE AND SUBTITLE Experimental Evaluation of Face Gears for Aerospace Drive System Applications			5. FUNDING NUMBERS WU-505-62-36 1L161102AH45	
6. AUTHOR(S) Robert F. Handschuh, David G. Lewicki, Gregory F. Heath, and Robert B. Bossler, Jr.				
7. PERFORMING ORGANIZATION NAME(S) AND ADDRESS(ES) NASA Lewis Research Center Cleveland, Ohio 44135-3191 and Vehicle Propulsion Directorate U.S. Army Research Laboratory Cleveland, Ohio 44135-3191			8. PERFORMING ORGANIZATION REPORT NUMBER E-10265	
9. SPONSORING/MONITORING AGENCY NAME(S) AND ADDRESS(ES) National Aeronautics and Space Administration Washington, D.C. 20546-0001 and U.S. Army Research Laboratory Adelphi, Maryland 20783-1145			10. SPONSORING/MONITORING AGENCY REPORT NUMBER NASA TM-107227 ARL-TR-1109	
11. SUPPLEMENTARY NOTES Prepared for the Seventh International Power Transmission and Gearing Conference sponsored by the American Society of Mechanical Engineers, San Diego, California, October 6-9, 1996. Robert F. Handschuh and David G. Lewicki, Vehicle Propulsion Directorate, U.S. Army Research Laboratory, Lewis Research Center; Gregory F. Heath, McDonnell Douglas Helicopter Company, Mesa, Arizona; Robert B. Bossler, Jr., Private Consultant, Hacienda Heights, California. Responsible person, Robert F. Handschuh, organization code 2730, (216) 433-3969.				
12a. DISTRIBUTION/AVAILABILITY STATEMENT Unclassified - Unlimited Subject Category 37 This publication is available from the NASA Center for AeroSpace Information, (301) 621-0390.			12b. DISTRIBUTION CODE	
13. ABSTRACT (Maximum 200 words) The experimental evaluation of face gears has been ongoing at NASA Lewis since 1991. Testing to date has focused on the feasibility of using this gear mesh to transfer power between intersecting shafts as found in helicopter main rotor transmissions. The focus of the experiments has been to determine the failure modes and load capacity of this gear mesh operated in a simulated helicopter transmission environment. At this time tests have been completed on a total of ten sets of face gears using a test facility located at NASA Lewis. Surface pitting was the predominant failure mode generated, however bending failures were also experienced. All tooth fractures due to pitting or bending occurred on the gear member. The spur gear pinion typically only had minor wear. Results from these tests indicated that the components would have to use aerospace gear materials and advanced manufacturing procedures to achieve the desired long component life.				
14. SUBJECT TERMS Gears; Transmissions; Mechanical drives			15. NUMBER OF PAGES 10	
			16. PRICE CODE A02	
17. SECURITY CLASSIFICATION OF REPORT Unclassified	18. SECURITY CLASSIFICATION OF THIS PAGE Unclassified	19. SECURITY CLASSIFICATION OF ABSTRACT Unclassified	20. LIMITATION OF ABSTRACT	