



US Army Corps
of Engineers
Vicksburg District

LOCK AND DAM NO. 4
RED RIVER WATERWAY, LOUISIANA

FOUNDATION REPORT

DEPARTMENT OF THE ARMY
VICKSBURG DISTRICT

DISTRIBUTION STATEMENT A
Approved for public release
Distribution Unlimited

21

March 1996

19961009 113

REPORT DOCUMENTATION PAGE

Form Approved
OMB No. 0704-0188

Public reporting burden for this collection of information is estimated to average 1 hour per response, including the time for reviewing instructions, searching existing data sources, gathering and maintaining the data needed, and completing and reviewing the collection of information. Send comments regarding this burden estimate or any other aspect of this collection of information, including suggestions for reducing this burden, to Washington Headquarters Services, Directorate for Information Operations and Reports, 1215 Jefferson Davis Highway, Suite 1204, Arlington, VA 22202-4302, and to the Office of Management and Budget, Paperwork Reduction Project (0704-0188), Washington, DC 20503.

1. AGENCY USE ONLY (Leave blank)	2. REPORT DATE MARCH 1996	3. REPORT TYPE AND DATES COVERED FOUNDATION REPORT - FINAL	
4. TITLE AND SUBTITLE LOCK AND DAM NO. 4 FOUNDATION REPORT		5. FUNDING NUMBERS NA	
6. AUTHOR(S) VICKSBURG DISTRICT CORPS OF ENGINEERS			
7. PERFORMING ORGANIZATION NAME(S) AND ADDRESS(ES) U.S. ARMY ENGINEER DISTRICT, VICKSBURG 4155 CLAY STREET VICKSBURG, MS 39180-3435 CELMK-ED-G		8. PERFORMING ORGANIZATION REPORT NUMBER NA	
9. SPONSORING / MONITORING AGENCY NAME(S) AND ADDRESS(ES) U.S. ARMY ENGINEER DISTRICT, VICKSBURG 4155 CLAY STREET VICKSBURG, MS 39180-3435		10. SPONSORING / MONITORING AGENCY REPORT NUMBER NA	
11. SUPPLEMENTARY NOTES NONE			
12a. DISTRIBUTION / AVAILABILITY STATEMENT APPROVED FOR PUBLIC RELEASE DISTRIBUTION IS UNLIMITED		12b. DISTRIBUTION CODE	
13. ABSTRACT (Maximum 200 words) REPORT PREPARED TO PROVIDE INFORMATION TO THOSE WHO MAY INVESTIGATE FUTURE PROBLEMS ON THIS STRUCTURE AND FOR THOSE INVOLVED IN DESIGNING SIMILAR STRUCTURES. THIS REPORT SERVES AS A BASIS FOR THOSE PERFORMING PERIODIC INSPECTIONS.			
14. SUBJECT TERMS LOCK AND DAM NO. 4, FOUNDATION REPORT, GEOLOGY PERIODIC INSPECTION, RED RIVER WATERWAY		15. NUMBER OF PAGES 108	
		16. PRICE CODE	
17. SECURITY CLASSIFICATION OF REPORT UNCLASSIFIED	18. SECURITY CLASSIFICATION OF THIS PAGE	19. SECURITY CLASSIFICATION OF ABSTRACT	20. LIMITATION OF ABSTRACT UL

GENERAL INSTRUCTIONS FOR COMPLETING SF 298

The Report Documentation Page (RDP) is used in announcing and cataloging reports. It is important that this information be consistent with the rest of the report, particularly the cover and title page. Instructions for filling in each block of the form follow. It is important to *stay within the lines* to meet *optical scanning requirements*.

Block 1. Agency Use Only (Leave blank).

Block 2. Report Date. Full publication date including day, month, and year, if available (e.g. 1 Jan 88). Must cite at least the year.

Block 3. Type of Report and Dates Covered. State whether report is interim, final, etc. If applicable, enter inclusive report dates (e.g. 10 Jun 87 - 30 Jun 88).

Block 4. Title and Subtitle. A title is taken from the part of the report that provides the most meaningful and complete information. When a report is prepared in more than one volume, repeat the primary title, add volume number, and include subtitle for the specific volume. On classified documents enter the title classification in parentheses.

Block 5. Funding Numbers. To include contract and grant numbers; may include program element number(s), project number(s), task number(s), and work unit number(s). Use the following labels:

C - Contract	PR - Project
G - Grant	TA - Task
PE - Program Element	WU - Work Unit Accession No.

Block 6. Author(s). Name(s) of person(s) responsible for writing the report, performing the research, or credited with the content of the report. If editor or compiler, this should follow the name(s).

Block 7. Performing Organization Name(s) and Address(es). Self-explanatory.

Block 8. Performing Organization Report Number. Enter the unique alphanumeric report number(s) assigned by the organization performing the report.

Block 9. Sponsoring/Monitoring Agency Name(s) and Address(es). Self-explanatory.

Block 10. Sponsoring/Monitoring Agency Report Number. (If known)

Block 11. Supplementary Notes. Enter information not included elsewhere such as: Prepared in cooperation with...; Trans. of...; To be published in.... When a report is revised, include a statement whether the new report supersedes or supplements the older report.

Block 12a. Distribution/Availability Statement. Denotes public availability or limitations. Cite any availability to the public. Enter additional limitations or special markings in all capitals (e.g. NOFORN, REL, ITAR).

DOD - See DoDD 5230.24, "Distribution Statements on Technical Documents."

DOE - See authorities.

NASA - See Handbook NHB 2200.2.

NTIS - Leave blank.

Block 12b. Distribution Code.

DOD - Leave blank.

DOE - Enter DOE distribution categories from the Standard Distribution for Unclassified Scientific and Technical Reports.

NASA - Leave blank.

NTIS - Leave blank.

Block 13. Abstract. Include a brief (*Maximum 200 words*) factual summary of the most significant information contained in the report.

Block 14. Subject Terms. Keywords or phrases identifying major subjects in the report.

Block 15. Number of Pages. Enter the total number of pages.

Block 16. Price Code. Enter appropriate price code (*NTIS only*).

Blocks 17. - 19. Security Classifications. Self-explanatory. Enter U.S. Security Classification in accordance with U.S. Security Regulations (i.e., UNCLASSIFIED). If form contains classified information, stamp classification on the top and bottom of the page.

Block 20. Limitation of Abstract. This block must be completed to assign a limitation to the abstract. Enter either UL (unlimited) or SAR (same as report). An entry in this block is necessary if the abstract is to be limited. If blank, the abstract is assumed to be unlimited.

DISCLAIMER NOTICE



THIS DOCUMENT IS BEST QUALITY AVAILABLE. THE COPY FURNISHED TO DTIC CONTAINED A SIGNIFICANT NUMBER OF COLOR PAGES WHICH DO NOT REPRODUCE LEGIBLY ON BLACK AND WHITE MICROFICHE.

RED RIVER WATERWAY
LOUISIANA, TEXAS, ARKANSAS, AND OKLAHOMA
MISSISSIPPI RIVER TO SHREVEPORT, LOUISIANA

LOCK AND DAM NO. 4 FOUNDATION REPORT

TABLE OF CONTENTS

<u>Para No.</u>	<u>Title</u>	<u>Page No.</u>
SECTION I - INTRODUCTION		
1-01.	Authorization	1-1
1-02.	Purpose and Scope	1-1
1-03.	Authorized Project Description	1-1
	a. Overall Project Description	1-1
	b. Mississippi River to Shreveport Reach	1-1
1-04.	Datum	1-1
1-05.	Lock and Dam No. 4	1-2
	a. Location	1-2
	b. Description	1-2
1-06.	Disposition of Report	1-2
1-07.	References	1-2
SECTION II - INVESTIGATIONS		
2-01.	General	2-1
	a. General	2-1
	b. Methods	2-1
2-02.	Pre-Construction Subsurface Investigations	2-1
	a. General	2-1
	b. New Orleans District (Phase I)	2-1
	c. Vicksburg District (Phase II)	2-2
	d. Vicksburg District (Phase III)	2-2
	e. Vicksburg District (Phase IV)	2-2
	f. Vicksburg District (Phase V)	2-2
	g. Vicksburg District (Phase VI)	2-2
	h. Vicksburg District (Phase VII)	2-2
2-03.	Investigations Performed During Construction	2-3
2-04.	Ground Water Investigations	2-4
2-05.	Other Field Investigations	2-5
	a. Pressuremeter Tests	2-5
	b. Earth Resistivity Test	2-5
2-06.	Laboratory Testing	2-5
SECTION III - GEOLOGY		
3-01.	Regional Geology	3-1
3-02.	Site Geology	3-1
	a. General	3-1
	b. Topstratum	3-1
	c. Substratum	3-2
	d. Tertiary	3-3

TABLE OF CONTENTS (CONTINUED)

<u>Para No.</u>	<u>Title</u>	<u>Page No.</u>
SECTION IV - DESIGN CONSIDERATIONS		
4-01.	Design Parameter	4-1
	a. Lock and Dam, Guidewalls, Channels and Closure Dam	4-1
	b. Other Areas	4-2
4-02.	Design Procedures	4-3
	a. General	4-3
	b. Sliding Stability	4-3
	c. Bearing Capacity	4-3
	d. Uplift	4-3
	e. Settlement	4-3
	f. Excavation and Cofferdam Slopes	4-4
	g. Closure Dam	4-4
	h. Upstream Approach Channel	4-4
	i. Downstream Approach Channel	4-5
4-03.	Backfill Drainage and Underslab Relief Systems	4-5
	a. General	4-5
	b. Filter Design	4-5
4-04.	Channel Protection	4-6
	a. Stone Protection and Channel Protection	4-6
	b. Gradation Limits	4-7
	c. Engineering Fabric	4-7
	d. Filter and Bedding Material Design	4-7
	e. Riprap and Graded Stone Produced on Site	4-7
SECTION V - EXCAVATION PROCEDURES		
5-01.	Excavation Grades	5-1
5-02.	Dewatering Provisions	5-1
5-03.	Overburden Excavation	5-1
5-04.	Dewatering System	5-2
SECTION VI - CHARACTER OF THE FOUNDATION		
6-01.	Foundation Surfaces of Each Component	6-1
6-02.	Condition of the Foundation	6-1
	a. Dam	6-1
	b. Lock	6-2
6-03.	Water Problems	6-2
6-04.	Foundation Materials Mapped	6-2
SECTION VII - FOUNDATION TREATMENT		
7-01.	Drainage Provisions	7-1
	a. Underslab Drainage System	7-1
	b. Backfill Drainage System	7-1
7-02.	Sheet pile	7-1
7-03.	Instrumentation	7-2

TABLE OF CONTENTS (CONTINUED)

<u>Para No.</u>	<u>Title</u>	<u>Page No.</u>
SECTION VIII - CHANGES FROM DESIGN		
8-01.	Tertiary Rock	8-1
	a. Stilling Basin and Gated Dam	8-1
	b. Upstream Guardwall	8-1
	c. Upstream Return Wall	8-2
	d. Downstream Return Wall	8-2
	e. Rock Remaining in Riverside Backfill	8-2
8-02.	Changes in Backfill Materials	8-2
8-03.	Reuse of Excavated Tertiary Rock as Riprap	8-2
8-04.	Backfill collector system Manholes	8-3
SECTION IX- POSSIBLE FUTURE PROBLEMS		
9-01.	Backfill Collector System	9-1

TABLE OF CONTENTS (CONTINUED)

PLATES

1. Project Location and Vicinity Map
2. Completed Plan
3. Upstream Channel Plan
4. Lock and Dam Plan
5. Downstream Channel Plan
6. Excavation For Structures with Geologic Cross-Section and Geologic Sampling
7. Investigative Boring Profiles
8. Unified Soil Classification System
9. Lock Structure, Plan, and Elevation
10. Lock Excavation and Backfill Sections
11. Lock Excavation and Backfill Sections
12. Dam Structure Plan and Elevations
13. Dam Excavation Backfill Sections
14. Dam Excavation Backfill Sections
15. Stone Protection Details
16. Dewatering and Monitoring Plan
17. Geologic Cross Section
18. Geologic Cross Section
19. Monoliths D-1 thru D-4 Underdrain System Plans, Sections, and Details
20. Crest Gated Spillway Monolith D-5 Underdrain System Plans, Sections, and Details
21. Monoliths D-1 thru D-5 Underdrain System Sections and Details
22. Monoliths D-1 thru D-4 Underdrain System Sections and Details
23. Lock Collector Drainage System - Manholes and Details
24. Sheet Piling Layout
25. Lock and Dam Sheet Piling Sections
26. Tainter Gate and Crest Gate Spillway Instrumentation
27. Lock Instrumentation Plan
28. Lock Instrumentation Sections
29. Closure Dam Instrumentation
30. Closure Dam Instrumentation - Details
31. Lock and Dam Instrumentation Tabulation
32. Closure Dam Plan, Sections, and Details

FIGURES

- Figure 3-1. Elevation of the Top of Tertiary
Figure 4-1. Filter Material
Figure 4-2. Riprap Gradation Curves
Figure 4-3. Riprap Gradation Curves
Figure 4-4. Riprap Gradation Curves
Figure 4-5. Gradation Graded Stone C
Figure 4-6. Gradation Graded Stone B
Figure 4-7. Bedding Material #1
Figure 4-8. Bedding Material #2

TABLE OF CONTENTS (CONTINUED)

PHOTOGRAPHS

1. Completed structure.
2. Completed structure.
3. Exploring for Tertiary rock in the upstream channel.
4. Government well used for pump test. Note encrusted sand and gravel encapsulating the well screen.
5. Government installed well used for pump test. Note encrustation caused by ground water.
6. Fresh exposure of Tertiary claystone at the base of the Prairie Terrace alluvium.
7. Exposure of Tertiary materials during low water in the excavation for the downstream access channel.
8. Tertiary sand containing minor rock stringers.
9. Exposure of Tertiary sand and clay at final grade. Note differential weathering.
10. Lenticular sandstone "weathering out" from Tertiary sand matrix.
11. Laminated Tertiary claystone.
12. Freshly excavated Tertiary claystone with 2 inch rock stratum.
13. Tertiary rock.
14. Excavating Tertiary rock using a hydraulic hammer.
15. Excavating Tertiary rock stratum using hydraulic hammer.
16. Tertiary rock to be transported to the spoil area.
17. Placement of R200 riprap on bedding stone No. 1 Downstream channel.
18. Placement of R650 riprap on filter stone on engineering fabric riverside of lock monolith L-17.
19. Engineering fabric installed in upstream channel.
20. Tertiary rock after processing for reuse as graded stone.
21. Tertiary rock after processing for reuse as riprap.
22. General view of the site February 1993. Crane in the foreground is located in the stilling basin.
23. Cutter head dredge excavating in the downstream channel.
24. Typical dewatering well.
25. Wellpoint system used to lower Tertiary hydrostatic pressures for the gated dam excavation.
26. Temporary collector ditches and sump to dispose of surface water.
27. Backfilling upstream of the crest gated spillway with pervious materials. Foundation for the crest gated spillway and overflow wall has been backfilled with fully compacted select sand.
28. Processing select sand from dredged sand.
29. Spreading filter sand "B" on the foundation for the gated dam.
30. Filter gravel "C" beneath gated dam. Note stabilization slab.
31. Sheet pile installation and filter placement beneath the gated dam (right) and stilling basin (left).

TABLE OF CONTENTS (CONTINUED)

32. Installation of the stainless steel collector system beneath the stilling basin. Note filter materials and sheetpiling.
33. Installation of the stainless steel collector system beneath the stilling basin.
34. Outlet pipe for underslab drainage system beneath monolith D-4. Note permanent piezometer P-31 and P-32 in foreground.
35. Placement of stabilization slab for the gated dam. Note discharge pipes for the underslab drainage system and sheet piles.
36. Installation of sheet pile in the foundation for the gated dam.
37. Sheet pile installation beneath the gated dam and stilling basin. Note government installed test well in foreground.
38. Permanent piezometer beneath the stilling basin.
39. Rock stratum approximately 50 feet riverside of lock (adjacent to monoliths L-6/7 through L-17). Portions of this rock stratum were left in place in areas scheduled for random or pervious backfill.
40. Removing Tertiary rock stratum 2 feet below final grade in the upstream guardwall area to allow installation of sheet pile.
41. Tertiary rock stratum left in place downstream of the lower lock gate.
42. Tension cracks preceding bank caving, upstream access channel.
43. Backfill collector system, manhole #1.
44. Interior of backfill collector system, manhole #1.

RED RIVER WATERWAY
LOUISIANA, TEXAS, ARKANSAS, AND OKLAHOMA
MISSISSIPPI RIVER TO SHREVEPORT, LOUISIANA

CONSTRUCTION FOUNDATION REPORT
LOCK AND DAM NO. 4

SECTION I - INTRODUCTION

1-01. Authorization. Public Law 90-483, 90th Congress, approved 13 August 1968, authorized the construction of the "Red River Waterway, Louisiana, Texas, Arkansas, and Oklahoma" project in accordance with the recommendations of the Chief of Engineers as contained in House Document No. 304, 90th Congress, 2d Session.

1-02. Purpose and Scope. This document presents the "as built" foundation conditions for Lock and Dam No. 4 of the Red River Waterway Project. It was prepared to fulfill the requirements contained in ER 1110-1-1801, Construction Foundation Reports, 15 December 1981, and CELMK-CD SOP 415-216 Construction Supervision and Inspection, 24 February 1984 (Paragraph 2-31).

1-03. Authorized Project Description.

a. Overall Project Description. The overall project consists of four reaches: (1) Mississippi River to Shreveport, Louisiana; (2) Shreveport, Louisiana, to Daingerfield, Texas; (3) Shreveport, Louisiana, to Index, Arkansas; and (4) Index, Arkansas, to Denison Dam, Texas.

b. Mississippi River to Shreveport Reach. The Mississippi River to Shreveport reach of the project is located along the Red River in central and northwestern Louisiana. Within this reach, the project provides a navigable channel approximately 236 miles long, 9 feet deep, and 200 feet wide from the Mississippi River to Shreveport via the Old and Red Rivers. Five locks and dams furnish the required lift of 141 feet. The New Orleans District performed preliminary geotechnical investigations for all five locks and dams as well as detailed explorations and designs for Lock and Dam Nos. 1 and 2. Vicksburg District performed detailed geotechnical explorations and geotechnical designs for Lock and Dam Numbers 3, 4, and 5. A review of the explorations and design of Lock and Dam No. 4 is covered in Sections 2 and 4 of this report.

1-04. Datum. All elevation datum used in this memorandum are referenced to feet NGVD (National Geodetic Vertical Datum).

1-05. Lock and Dam No. 4.

a. Location. The Lock and Dam No. 4 project is located in a cutoff between old (1967) river miles 205.0 and 210.0, approximately 12 river miles downstream from the city of Coushatta, Louisiana. This is the fourth lock and dam complex of the five locks and dams that comprise the Mississippi River to Shreveport, Louisiana, reach of the Red River Project. The project is located in Red River Parish, Louisiana. (Photographs 1 and 2).

b. Description. The location of the lock and dam is shown on Plate 1. The completed plan for the lock and dam is shown on Plate 2. The dam consists of a gated spillway with five 60 foot wide tainter gates with a sill at elevation 85 and a stilling basin at elevation 62. Adjacent to the tainter gates is a 100 foot wide crest gated dam with an ogee section at elevation 113 and a 154 foot wide concrete overflow weir at elevation 122.0. The single 84-foot wide by 685-foot long (nominal size) lock is located north of the gated spillway and connected to the spillway by a cutoff wall 58.0 feet in length with a top elevation of 128.0. The maximum lift (and head) for the lock and dam is from minimum tailwater (controlled condition) at elevation 95.0 to normal pool at elevation 120.0. Navigation will cease downstream of the lock and dam at the 10-year flood elevation of 121.6. Project design flood elevation is 130.6 upstream of the lock and dam. The site plan for the lock and dam is shown on Plates 3, 4, and 5. The major features of the lock and dam complex were constructed in two phases. Phase I included the majority of the structural excavation, installation of the dewatering system, construction of a Resident Engineers Office, and construction of temporary access roads. Phase II involved construction of the lock and dam complex, approach channels, permanent access roads, supplementary pressure relief in the suballuvial Tertiary formation, and construction of the closure dam.

1-06. Disposition of Report. This report has been distributed in accordance with ER-1110-2-1801. Text, plates and photographs are available in digitized form from the Vicksburg District Corps of Engineers, Engineering Division, Design Branch. Materials have been archived under file number R-14-206.

1-07. References. To facilitate implementation of the Inspection and Evaluation Program, and to avoid repetition of information presented previously, the following references are listed.

a. House Document No. 304, 90th Congress, 2d Session (the authorizing report).

- b. Design Criteria Report, February 1972, and all endorsements thereto.
- c. Existing Bridge Report, April 1972, and all endorsements thereto.
- d. Pre-construction and Post-construction Groundwater Levels, Lock and Dam No. 4, Red River Valley, Louisiana, by A.H. Ludwig, U.S. Geological Survey, Open File Report, 1979.
- e. Agricultural Observation and Ground Water Study, Red River Waterway Project, Main Report and Appendix IV (L&D No. 4), by Soil Conservation Service in cooperation with U.S. Geological Survey, October 1975.
- f. Design Memorandum No. 2, GDM- Phase I, Plan Formulation Site Selection, Mississippi River to Shreveport, Louisiana, May 1976, and all endorsements thereto.
- g. Design Memorandum No. 3, Hydrology, Mississippi River to Shreveport, Louisiana, March 1974, and all endorsements thereto.
- h. Design Memorandum No. 10, Hydrology and Hydraulic Design, Lock and Dam No. 1, January 1974, and all endorsements thereto.
- i. Standardization Report, Locks and Dams Nos. 1 through 5, March 1977, and all endorsements thereto.
- j. Design Memorandum No. 18, Hydrology and Hydraulic Design, John H. Overton Lock and Dam, June 1980, and all endorsements thereto.
- k. Quality of Water in the Red River Alluvial Aquifer, Shreveport to the mouth of the Black River, Louisiana, by A.H. Ludwig, U.S. Geological Survey, Open File Report, 1974.
- l. Final Environmental Statement, May 1973, Final Supplement No. 1 to Final Environmental Statement, February 1977, and Final Supplement No. 2 to Final Environmental Statement, November 1983, Mississippi River to Shreveport, Louisiana.
- m. General Design Memorandum No. 21, General Design, Phase II - Project Design, Lock and Dam No. 4, May 1987, and all endorsements thereto.
- n. Design Memorandum No. 27, Sources of Construction Materials, Lock and Dam Nos. 4 and 5, December 1989, and all endorsements thereto.

o. Design Memorandum No. 28, Detailed Design, Lock and Dam No. 4, August 1989, and all endorsements thereto.

p. Design Memorandum No. 29 (Revised) Hydrology and Hydraulic Design, Lock and Dam No. 4, March 1986, and all endorsements thereto.

q. Design Memorandum No. 38, Aesthetical Enhancement Report, Pool Nos. 1 through 5, November 1977, and all endorsements thereto.

In addition to the above general references, specific design references appear in the particular section to which they pertain.

SECTION II - INVESTIGATIONS

2-01. General.

a. General. Site investigations for the geotechnical design of Lock and Dam No. 4 were performed by both the New Orleans District and the Vicksburg District. Three individual sites were explored during seven periods of field investigations (hereafter referred to as Phases I through VII). In addition, five geotechnical investigations were performed during the construction period to better establish the sub-surface conditions in selected areas.

b. Methods. Investigative techniques employed include drilling exploratory borings, performing geophysical logs, and digging test pits. Borehole samples were recovered using a variety of devices including a standard splitspoon, 6-inch diameter core barrel, 2-1/2 inch diameter drive tube, 5-inch diameter Shelby tube, and an auger. In the intervals where samples were not taken, the cuttings were examined and the action of the drill stem was noted in order to establish the lithology of the soil/rock unit. Down-hole geophysical logs consisting of spontaneous potential (SP), resistivity, and natural gamma radiation were performed on all holes except where noted. Detailed geologic field logs (ENGR FORM 1836) were prepared for some of the New Orleans investigative borings and most of the Vicksburg District investigative borings.

2-02. Pre-Construction Subsurface Investigations.

a. General. Investigations for the design of Lock and Dam No. 4 occurred over a ten year period from 1979 to 1989. Hundreds of borings, geophysical logs, and laboratory tests were performed. The results of geological investigations, geotechnical boring logs, geophysical logs, and an extensive laboratory testing program have been assembled in Design Memorandum No. 28, Volume IV (Geotechnical Portfolio) and are not reproduced in this report.

b. New Orleans District (Phase I). The initial exploration conducted at the Lock and Dam 4 site was performed by Law Engineering and Testing Company under a contract with the New Orleans District Corps of Engineers. Explorations were conducted during the period October 1979 to January 1981. Forty-eight borings, ranging from 110 to 270 feet in depth were drilled on the floodplain along an alignment (Site 1) which was subsequently abandoned. The first 24 borings (4-1D through 4-24) were drilled on a 1000 foot grid pattern. The second 24 borings (borings 4-25 through 4-48) were drilled along the proposed lock and dam centerlines (which intersected at boring 4-28). Geophysical data

were not obtained on these borings and detailed geologic logs (ENG FORM 1836) were prepared for borings 4-34, 4-36, and 4-41 only.

c. Vicksburg District (Phase II). During the period March through July 1985, the Vicksburg District, Geotechnical Branch drilled 59 exploratory borings (4-49 through 4-107) at Site 2, located approximately 300 feet downstream of Site 1 and with centerlines intersecting near boring 4-29. These borings varied in depth from 30 feet to 200 feet with most borings extending to a depth near elevation -25.

d. Vicksburg District (Phase III). During the summer of 1985, the site for Lock and Dam 4 was moved approximately 1200 feet to the northeast (Site III). This was done to address hydraulic design criteria (having to do with siltation problems) that became evident with the operation of L.C. Boggs Lock and Dam. Phase III investigation at Site III were conducted by the Vicksburg District, Geotechnical Branch during the period January to June 1986. These investigations consisted of 53 borings (LD4-108-86U through LD4-160-86U).

e. Vicksburg District (Phase VI). Investigations for the detailed geotechnical design of Lock and Dam No. 4 consisted of 36 borings completed during the period September to November 1987 (LD4-161-87U through LD4-199-87U excluding #166, 171, and 173 which were not drilled).

f. Vicksburg District (Phase V). During the months of November 1988 and January 1989 twenty-one test pits, ranging from 5 to 9 feet in depth, were excavated at the Lock and Dam No. 4 construction site. The purpose of the test pit excavations was to evaluate the need for seepage barriers (clay blankets or slurry trenches) during the construction phase.

g. Vicksburg District (Phase VI). During the period 30 January to 2 March 1989, thirty-five (35) exploratory borings (LD4-200-89U through LD4-223-89U and LD4-234-89U through LD4-244-89U) were drilled along the alignment of the permanent (south) access road. These borings ranged from 11 feet to 78.5 feet in depth. No geophysical logs were made for these holes nor were geological logs (ENGR FORM 1836) made for borings LD4-237-89U, LD4-238-89U and LD4-244-89U.

h. Vicksburg District (Phase VII). Overlapping with Phase VI investigations during the period February 1989 to August 1989, investigative borings were drilled in the approach channels (borings LD4-224-89U through LD4-233-89U), borrow areas adjacent to the access road (LD4-246-89U through LD4-263-89), for the closure dam (LD4-264-89U through LD4-269-89U), and around the alignments for the containment dikes for dredge disposal areas #3

and #4 (LD4-270-89 through LD4-285-89). Approach Channel borings extended 50 to 75 feet. Borrow borings were drilled to a depth of 25 feet (except when conditions required hand auger borings in which case borings extended to 15 feet). Closure Dam borings extended 40 to 60 feet and containment dike borings extended to 50 feet. No geophysical logs were performed for any of these borings.

2-03. Investigations Performed During Construction. The initial investigation made at Lock and Dam No. 4 during construction was performed by Fugro-McClelland, the sub-contractor for dewatering. Fugro-McClelland contended that "differing site conditions" existed in the Tertiary age sediments that differed materially from what they were expecting based on the government's pump test and other published data. (The Tertiary aquifer in the stilling basin area of the gated dam did not experience the expected drawdown when pumped by 6 dewatering well installed by Fugro-McClelland.) Investigations consisted of seven borings made with a 6-inch hollow stem auger and a standard splitspoon sampler. Samples collected from these borings closely agreed with the published borings. Investigations were made to delineate the presence of Tertiary rock strata which interfered with the sheet pile installation in the stilling basin and gated dam area and dredging in the approach channels and to establish the availability of adequate, suitable borrow in the upstream approach channel. The Government investigated the presence of rock beneath the stilling basin and gated dam. An attempt was made to define the rock using a cone penetrometer. When this failed, five exploratory borings (LD4-229-93 through LD4-233-93) were made during May 1993 using rotary drilling methods. As a consequence of the presence of the rock strata, certain sheet piles were not advanced to design grade. At the request of the Resident Engineer, the mobilized drill rig and crew moved to the upstream channel area and drilled six borrow borings to evaluate the quality and quantity of the reusable materials remaining in place. (This exploration became necessary because, with the completion of the Piermont Revetment, severe bank caving began in the area of the LD4 upstream approach channel, removing material that had been designated as backfill for the structure.) These borings are designated as LD4-334-93 through LD4-339-93. (It should be noted that the Resident Office referred to these borings as LD4-1-93B through LD4-6-93B in a series of correspondences). During the months of September and October 1993, the Geotechnical Branch drilled eight exploratory land borings (LD4-340-93U to LD4-347-93U) and five exploratory borings (LD4-348-93U to LD4-352-93U) from a floating platform to investigate the presence of Tertiary rock strata in the downstream access channel. The sampling was confined to the interval between elevations 81 and 75, a zone where the contractor had reported encountering rock during his dredging operation. The site conditions were essentially the same as

those depicted on the preconstruction borings (sandstone and siltstone lenses 0.1 to 0.2 of a foot in thickness). During the period 23 to 26 February 1994, the Geotechnical Branch performed explorations from a floating platform in the upstream channel. The contractor had reported "rock strata" which interfered with his dredging operation as high as elevation 96 (final grade for the upstream channel is 90). Ten exploratory borings (LD4-353-94U to LD4-362-94U) were drilled in areas designated by the contractor. The site conditions were essentially the same as those depicted on the preconstruction borings (sandstone and siltstone lenses 0.1 to 0.2 of a foot in thickness). The contractor persisted in his contention that rock strata were interfering with the dredging operation (in spite of the fact that minor rock is clearly shown on the investigative borings). The contractor mounted his own exploration program in the upstream channel which was witnessed by COE personnel from the district office during the period 5 to 9 April 1994. Explorations consisted of digging 106 exploration pits using a barge mounted backhoe (Photograph 3). Exploration pits were generally located on 25 foot centers in locations where the contractor had encountered problems. Rock was encountered above final grade in 22 of the locations. The shallowest rock was located at elevation 95.4. The Corps contended that the site conditions were essentially the same as those depicted on the preconstruction borings although the Corps did relax final grade to accommodate the rock in several small areas. (The contract required protection stone on the channel bottom. Where the scheduled work would have consisted of removing rock and replacing it with stone, the rock was allowed to remain in place.) The locations and graphic logs for borings LD4-329-93 through LD4-333-93 are shown on Plates 6 and 7. Plate 8 contains a boring legend. Borings LD4-334-93 through LD4-362-94U were made at locations that were subsequently excavated (in the intervals sampled) and therefore do not contain any useful information on the post construction site conditions.

2-04. Ground Water Investigations. A two-stage pump test was performed by the Vicksburg District during the period 22 June to 26 June 1987. The test well was located approximately 5 feet from the intersection of the lock and dam centerlines and extended to a depth of 172 feet (Photographs 4 and 5). The test well was installed in a 30-inch diameter hole and surrounded by filter gravel "E". The well was 14 inch O.D. and contained 132 feet of #30 slot low carbon steel well screen. The well screen fully penetrated both the Quaternary and Tertiary aquifers above a thick claystone bed considered an aquiclude. Three radial arrays of piezometers were installed in the northwest, northeast, and southeast directions. Each piezometer location contained two piezometer tips, one in the Quaternary aquifer and one in the Tertiary aquifer. Each tip was installed in a separate hole approximately 5 feet from its "nestmate". Each

piezometer contained a #10 slot plastic wellpoint surrounded by concrete sand. The test well was pumped at two rates, 100 and 200 GPM and piezometers were read for 48 hours at each pumping rate to assure that steady state conditions had developed. Flow was measured inside the well beginning at the bottom of the well and at 10 foot interval throughout the screened interval. Reading were taken with a velocity (flow) meter which could be lowered to the desired depth and measurements taken. The results of the ground water investigation revealed that the Tertiary aquifer has a permeability of 0.0146 feet per minute (based on the average of the two pump test flow rates) and the Quaternary aquifer has a permeability ranging from 0.02 to 0.03 feet per minute (based on the D10 size). For a complete review of the ground water investigations performed at Lock and Dam 4, including an analysis of ground water quality, see Design Memorandum 28; Detailed Design, Volume I and Volume II.

2-05. Other Field Investigations.

a. Pressuremeter Tests. Seven boreholes (LD4-P1-88 through LD4-P7-88) were drilled during the period 21-25 March 1988, to perform downhole pressuremeter tests. The holes were drilled into the Tertiary Formation. Holes were drilled using rotary drilling methods with Revert and a drag bit or a roller rock bit. Tests were conducted in very dense silty sand of the Wilcox Group. Probes were extended into the interval to be tested and expanded until the soil failed. The testing program revealed low strain elastic modulus values of 2,500 to 19,000 tons per square foot and high strain elastic modulus values of 1,000 to 2,500 tons per square foot. The results of this testing program are presented in Design memorandum 28; Detailed Design, Volume II, Plate II-6.

b. Earth Resistivity Test. Field measurements of earth resistivity were conducted along the dam centerline during the period 9-12 May 1989. Exploration depths of 100 feet were obtained using the Wenner Four Electrode Array (ASTM G 57) with an "a" spacing of 200 feet. The test results were used in the design of the electrical grounding system.

2-06. Laboratory Testing. Soil classification and water content determinations were made for all cohesive samples. Atterberg limits and unconfined compressive strengths were determined on selected cohesive samples. Granular samples were visually classified and grain size distributions were determined for selected samples. Triaxial shear and direct shear tests were performed on selected samples of clay (CH-CL), silty clay (CH-CL) and sandy clay (CH-CL). Triaxial shear tests consisted of Unconsolidated Undrained (Q) and Consolidated Undrained (R) tests. Pore pressure readings were made on all R tests. Consolidation tests were performed on selected cohesive samples.

Results of the laboratory testing program are presented in Design Memorandum 28; Detailed Design, Volume IV (Geotechnical Portfolio). Special, one time testing was performed on selected Tertiary sandstone samples from borings LD4-119-86U, LD4-125-86U, LD4-126-86U, and LD4-134-86U at the Waterways Experiment Station. Tests included Petrographic analysis, Uniaxial compressive strength, determination of Modulus of Elasticity, specific gravity, and absorption. Thermoluminescence dating techniques were performed on samples from borings LD4-91-85U, LD4-116-86U, LD4-117-86U, and LD4-125-86U in an attempt to age date the various Quaternary terraces present at the site. The results of this special testing program are presented in Design Memorandum 28; Detailed Design, Volume I, Tables 3-8 and 3-9.

SECTION III - GEOLOGY

3-01. Regional Geology. For a complete description of the regional geologic setting for Lock and Dam No. 4, see paragraph 3-02a of Design Memorandum No. 28 "Detailed Design", Volume I. The referenced DM contains a description of the physiography, topography, structure, tectonics, stratigraphy, ground water, mineral resources and construction materials encountered in the Central Louisiana area. No regional geologic features were discovered that adversely impacted the Lock and Dam No. 4 construction site.

3-02. Site Geology.

a. General. Lock and Dam No. 4 was constructed in the Quaternary alluvium of the Red River. The construction site involved Pleistocene Terrace deposits and Holocene alluvium. Both alluvial sequences consisted of a fine grained topstratum overlying a coarse grained substratum. Underlying the alluvial sequences are Tertiary age sediments assigned to the Wilcox Group. The foundation for all the lock and dam components was Tertiary age materials of the Wilcox Group. Holocene alluvial topstratum can be classified according to the environment in which it was deposited. Each topstratum type consists of a suite of materials which were deposited in a specific manner and display physical properties which vary within known limits. Topstratum types encountered in the construction of Lock and Dam No. 4 included natural levee (adjacent to the Red River), abandoned channel (across the upstream channel), and a point bar sequence. The abandoned channel and the natural levee were present in the approach channels but did not form the foundation for the structure. Pleistocene Prairie Terrace deposits were present in the protected area and constituted the bulk of the excavated materials within that area.

b. Topstratum. Lock and Dam No. 4 was constructed in an area where the ground surface formation consists of Pleistocene terrace deposits (Photograph 6). Holocene alluvium was present in the upstream and downstream approach channels (Photograph 7). In addition, the Holocene deposits formed a small, topographically low area at the downstream end of the protected area. All foundations for the lock and dam structure were located in areas of Pleistocene terrace. Excavation for the structure extended through the Pleistocene Terrace and into the underlying Wilcox Formation. The Prairie Terrace contains a fine grained upper stratum and a coarse grained substratum. The upper stratum consists of reddish brown, brown, and gray clay (CH-CL) and gray and brown silt (ML). These Pleistocene topstratum materials contain roots, lignite, and crumbly zones. No attempt was made to evaluate the consistency of the materials in the field due to desiccation associated with construction dewatering.

The majority of the Pleistocene topstratum clays (CH-CL) and silt (ML) from the structural excavation were utilized in construction of the cofferdam or stockpiled in the clay stockpile area during the Phase I construction contract for reuse in the closure dam. Topstratum clays (CH-CL) and silt (ML) that remained within the cofferdammed area or topstratum clays from the channel excavations were utilized as structural backfill. A small tributary stream crossed the site from north to south at approximate station 10+00L. This small stream lowered the ground surface approximately 30 feet as it incised itself in the Prairie Terrace (see preconstruction boring LD4-188-87U). Some reworking of the Pleistocene deposits occurred in this area although the lithology and stratigraphy are similar to that described for the Prairie Terrace with a 14 foot section of clay (CH-CL) and silt (ML) overlying a 13 foot section of silty sand (SM). Like the Prairie alluvium, this entire soil deposit was removed during excavation. Holocene topstratum consisted of point bar deposits (in both the upstream and downstream channels), an abandoned channel that crossed the upstream approach channel and a natural levee along the current Red River alignment. The Holocene point bar topstratum consisted of gray, and reddish brown clay (CH-CL) and silt (ML) with roots, and other vegetation. The clay (CH-CL) ranged from medium to stiff in consistency and contained silt strata and occasional silty sand pockets. The silt (ML) contained clay strata and sand strata. Designers anticipated reusing much of this point bar topstratum unit for impervious and random backfills. However, due to erosion and bank caving, especially after the completion of the Piermont Revetment, much of this deposit was lost. An abandoned channel crosses the upstream channel on a bearing of N 15°W at approximate station 25+00L. The abandoned channel's presence was evident in the surface topography. This topstratum feature had a thickness of approximately 40 feet and was composed of black, red, brown, and gray clay (CH), which ranged from soft to very stiff in consistency, and contained tree stumps, roots, silt strata, wood, lignite, concretions, and abundant shell fragments. The abandoned channel topstratum deposit also contained minor amounts of red and brown silt (ML) and silty sand (SM) with clay strata. The abandoned channel extended to approximate elevation 85 and it was completely removed in the area of the upstream approach channel. As noted earlier, a natural levee consisting of silt (ML) and silty sand (SM) was present in the upstream channel along the Red River. This topstratum type was not involved in any portion of the structural foundation.

c. Substratum. The substratum forms the alluvial aquifer and consists of two different units; a Holocene unit composed of fine sand (SP, SM, SP-SM) which is associated with the Recent point bar migrations, and a Pleistocene unit which is composed of silty sand (SM) and silty fine sand (SP-SM) deposited during an earlier alluviation of the valley. The lateral

boundary between these two units is the Holocene - Pleistocene contact and is reflected in the site topography. The Holocene unit is composed of brown, light brown, and gray sand (SP, SM, SP-SM) which is a continuation of the fining upward point bar sequence. Near the base of this unit, an intermittent layer of coarse sand (SP) and gravel (GP) was noted. This "channel lag" was left by channel migrations. Clay (CH) lenses and stringers were occasionally present in the substratum. The Pleistocene substratum unit is composed of fine silty sand (SM) with minor amounts of silty fine sand (SP-SM) with lignite. The Pleistocene unit extends from approximate elevation +125 to the top of the Tertiary Formation (elevation 80 to 105). The entire section was examined in the field (Photograph 6). Both of these units required extensive dewatering efforts before excavation could proceed as discussed in Section V.

d. Tertiary. Underlying the Quaternary alluvium at Lock and Dam No. 4 are formations of the (Undifferentiated) Wilcox Group. The Wilcox Group is Eocene in age. The top of the Wilcox is an erosional surface that varied from approximate elevation 60 to elevation 105 at the site, although boring LD4-177-87U, located 3500 feet south of the site, shows a Tertiary/alluvial interface at elevation 31. Figure 3-1 shows the elevation of the top of Tertiary prior to excavation. Generally speaking, the interface is at a higher elevation beneath the Pleistocene Terrace as compared to the Holocene alluvium. The Wilcox Formations were deposited by an accretionary shoreline and is deltaic to near shore marine in origin. The Wilcox is composed of light gray silty sand and brown to black clay(stone) with strata and ridges of gray, hard sandstone (Photographs 8, 9, and 10). The silty sand strata are local aquifers and some dewatering and pressure relief was required. The clay(stone) is a highly overconsolidated marine clay which was, none the less, excavated with conventional earth moving equipment (Photographs 11 and 12). The sandstone occurred as extremely hard layers or lenses, some more than 8 feet thick. It was necessary to pre-split some of the thicker sandstone layers (using a product called "Bent-O-Mite") prior to breaking the rock up with a tractor mounted hydraulic hammer (Photographs 13, 14, and 15). Where possible, the contractor processed the Tertiary stone for reuse as Graded Stone C, and R650 and R200 riprap (Photograph 16). (The reuse of the Tertiary rock as protection stone was the result of a contractor proposed VE suggestion. The government had considered reuse of the rock during the design phase and decided it was not in its best interest to require such reuse.) The presence of the sandstone caused problems with the sheet pile driving operation as discussed in Paragraph 7-02.

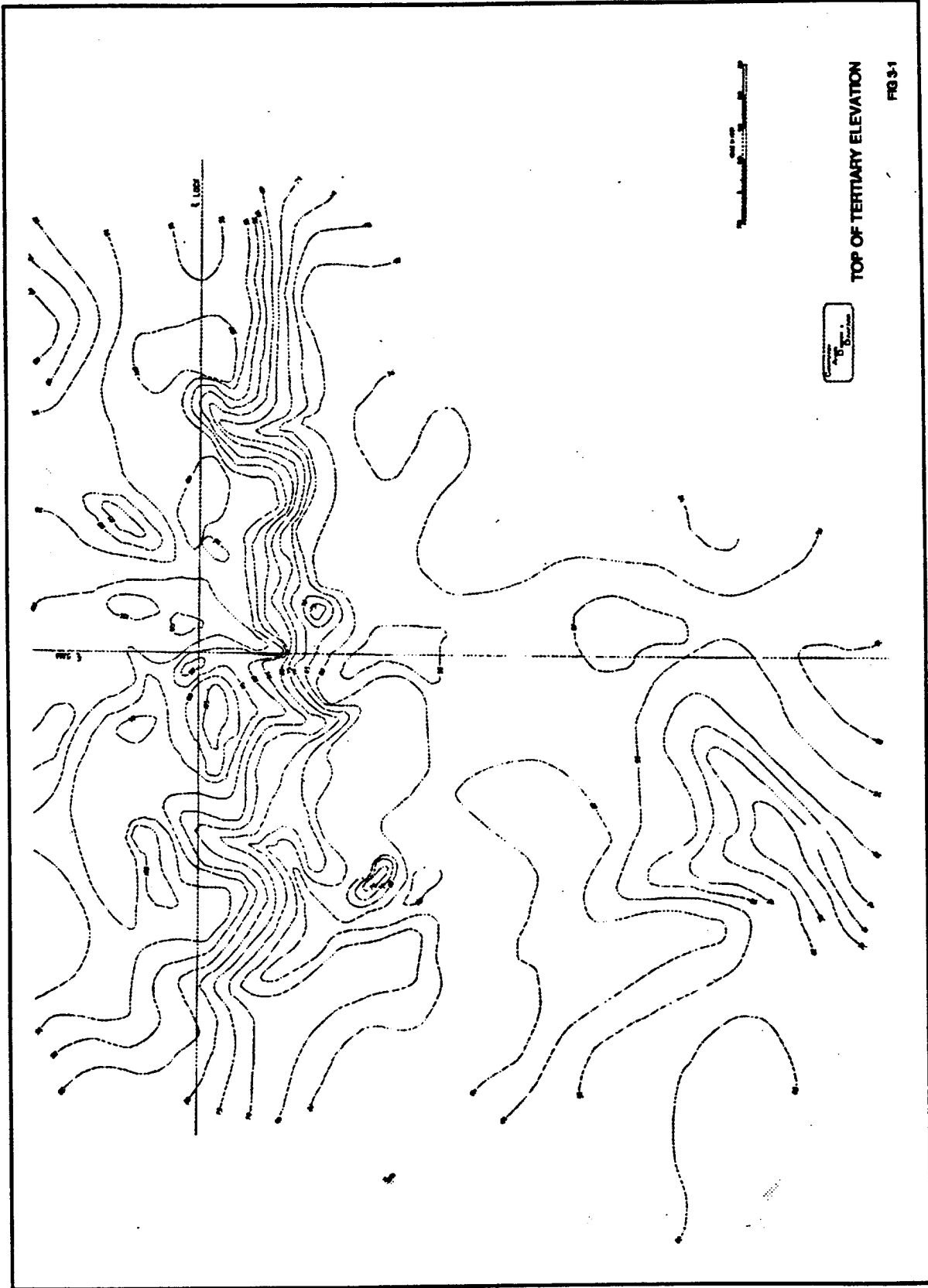

TOP OF TERTIARY ELEVATION

FIG. 3-1

SECTION IV - DESIGN CONSIDERATIONS

4-01. Design Parameter. As a result of the laboratory testing program outlined in Paragraph 2-06 of this report, the following strength parameters were utilized in the geotechnical design of Lock and Dam No. 4.

a. Lock and Dam, Guidewalls, Channels and Closure Dam. The following values were utilized in the design of the lock and dam, guidewalls, channels, and closure dam. The values discussed herein are shown at the end of this section.

(1) Quaternary Clays. Discontinuous thin lenses of clay (CH) were encountered in the substratum unit. These materials were assigned an undrained (Q) shear strength $\phi = 0^\circ$ with a cohesion of 1400 psf and a drained (S) shear strength of $\phi = 22^\circ$ with 0 cohesion. These clays were assigned a unit weight of 125 pcf. The insitu strength of the clay materials varies and strengths used in individual analyses were selected from strength data for nearest boring.

(2) Quaternary Silt. Silt (ML) materials were assigned an undrained (Q) shear strength of $\phi = 0$ with a cohesion of 300 psf and a drained (S) shear strength of $\phi = 30^\circ$ and a unit weight of 120 pcf.

(3) Quaternary Silty Sand. Clean foundation sand (SP, SM, SP-SM) was assigned a shear strength of $\phi = 30^\circ$ and a unit weight of 125 pcf.

(4) Tertiary Claystone. These materials are highly over consolidated clays (CH-CL). They were assigned an undrained (Q) shear strength of $\phi = 6^\circ$ with a cohesion of 2000 psf, a drained (S) shear strength of $\phi = 30^\circ$ with a cohesion of 1400 psf and a unit weight of 130 pcf.

(5) Deep Claystone. These materials were assigned an undrained (Q) shear strength of $\phi = 27^\circ$ (with a cohesion of 0 psf) and a drained (S) shear strength of $\phi = 30^\circ$ (with a cohesion of 0 psf). These materials were assigned a unit weight of 130 pcf.

(6) Tertiary Sand. Tertiary sands were assigned a shear strength of $\phi = 33^\circ$ for both the short term (Q) and long term (S) cases. These materials were assigned a unit weight of 130 pcf.

(7) Impervious Backfill. Clay used in the impervious upstream blanket and around the various backfill areas was assigned an undrained (Q) shear strength of $\phi = 0^\circ$ and a cohesion of 1500 psf. A drained (S) shear strength of $\phi = 24^\circ$ with no cohesion and a unit weight of 125 pcf were also used for this material.

(8) Pervious Backfill. Pervious backfills consisted of sand (SP) (known as select sand) and silty sand (SM) (known as pervious backfill). Both of these materials were assigned a shear strength of $\phi = 33^\circ$ and a unit weight of 125 pcf.

(9) Sand Filters. All sand filters were assigned shear strength values of $\phi = 30^\circ$ and unit weight of 125 pcf.

b. Other Areas. The following values were utilized in the design of the closure dam and spoil areas.

(1) Dredged And Dumped Silty Sand Fill. Dredged sand and silty sand were used in constructing the closure dam. These materials were assigned an undrained (Q) shear strength and a drained (S) shear strength of $\phi = 26^\circ$ with no cohesion. A unit weight of 120 pcf was assigned.

(2) Silt Deposited In Channel. It was assumed in the design that a certain quantity of silt (ML) would be deposited in the downstream channel area. This material was assigned an undrained (Q) strength of $\phi = 0^\circ$ and a cohesion of 500 psf, a drained (S) shear strength of $\phi = 26^\circ$ and a unit weight of 120 pcf.

(3) Riprap And Rock Fill. Riprap and other protection stone were used extensively on this project. Riprap was assigned a strength (both Q and S) of $\phi = 35^\circ$ and a unit weight of 130 pcf.

Design Parameters

TYPE OF MATERIAL	TYPE OF TEST							Saturated Unit Wt. pcf
	Q		R		S			
	ϕ	c	ϕ	c	ϕ	c		
	psf		psf		psf			
Quaternary Clay	0°	1400	--	--	22°	0	125	
Quaternary Silt	0°	300	--	--	30°	0	120	
Quaternary Silty Sands	30°	0	--	--	30°	0	125	
Tertiary Claystone	6°	2000	--	--	30°	1400	130	
Deep Claystone	27°	0	--	--	30°	0	130	
Tertiary Sands	33°	0	--	--	33	0	130	
Impervious Backfill	0°	1500	--	--	24°	0	125	
Pervious Backfill	33°	0	--	--	33°	0	125	
Sand Filters	30°	0	--	--	30°	0	125	
Dredged & Dumped Silty Sand Fill	26°	0	--	--	26°	0	120	
Silt by Deposition	0°	500	--	--	26°	0	120	
Riprap & Rock Fill	35°	0	--	--	35°	0	130	

4-02. Design Procedures.

a. General. The lock and the dam were evaluated with respect to sliding stability, bearing capacity, uplift and settlement. An integral part of the evaluation was the development of an underseepage analysis to predict uplift pressures with three different underslab drain efficiencies (0 percent, 50 percent, and 100 percent). For a complete review of the geotechnical design of Lock and Dam 4 see Design Memorandum No. 28 "Detailed Design".

b. Sliding Stability. The sliding stability of all components was evaluated for the basic loading conditions (the construction, normal operating and extreme operating cases). In addition, the lock and dam was evaluated for 13 special cases which included such external loads as earthquake, wind and barge impact. Sliding stability analyses were performed using computer program CSLIDE and calculations based on TL 1110-2-256 and EM 1110-2-1902. All resulting factors of safety were considered adequate.

c. Bearing Capacity. Bearing capacity calculations were performed using equations presented in the users manual for the computer program CBEAR for the construction, normal operating and extreme operating cases. The bearing capacity was computed considering the effects of embedment of foundation, inclined loads, sloping soil surfaces, eccentric loads in two dimensions, submerged soils and surcharges. All computed factors of safety exceeded the minimum required bearing capacity factor of safety which is 2.0.

d. Uplift. Uplift stability of the tainter gated spillway and stilling basin, crest gated spillway and scour slab, and critical lock monoliths was evaluated for the normal operating, loss of lower pool, maintenance (both scheduled and extreme), and one gate half open cases. Computations were made assuming the drainage system to be 0 percent effective (where present). The net force factor of safety for the tainter gate-stilling basin for the "one gate half open, drains 0 percent effective" loading condition was 1.13. This was the lowest computed factor of safety but still exceeds the required 1.1.

e. Settlement. The lock and dam is founded on insitu Tertiary silty sand (SM) and compacted pervious backfill (SP) with a minimum relative density of 80 percent. The stratum of Tertiary insitu silty sand extends to a point 15 feet to greater than 50 feet below the structure. Within the sand zone there may be zones of claystone. Settlement was computed based on elastic analysis in the Tertiary sand and conventional consolidation theory for the claystone. Elastic modulus in the Tertiary sand was measured with a borehole pressuremeter and an average modulus of 5000 tsf was recorded. The modulus was assumed to vary with

the square root of the insitu stress level. Claystone compressibility and rebound values were based on the results of odometer tests and values of $C_c = 0.051$ (for consolidation) and $C_r = 0.020$ (for reconsolidation) were utilized in the evaluation (since these clays are highly overconsolidated). (NOTE: these values were inadvertently transposed in the text of DM 33) The analysis evaluated rebound due to excavation, settlement induced by construction and finally rebound due to rewatering. Typically about 90% of the settlement and rebound is due to claystone properties and since the claystone is low plasticity, these movements occur concurrent with, or immediately following loading (or unloading). A complete check of the results was performed using hand calculations and a spreadsheet analysis based on Bossinesq's theory. Additional spot checks were performed using the computer program CSETT.

f. Excavation and Cofferdam Slopes. Slope stability for the cofferdam and excavation was investigated during the design phase using the computer program UTEXAS2. A construction case, post-construction case and earthquake case were analyzed using both drained and undrained strengths. Soil stratigraphy for evaluation of the excavation slopes was determined from the investigative borings and soil strengths are outlined in Paragraph 4-01a. Ground water was assumed at elevation 130. Fill for the cofferdam was included in the analysis as well as the design flood against these fills. The calculated factor of safety exceeded those required in all cases.

g. Closure Dam. The closure dam was evaluated for slope stability (Q construction and Q and S operating cases), settlement and underseepage. Factors of safety for stability of the downstream face were 1.76, 1.41, 1.64 and 1.36 for the (Q) end of construction, (Q) end of construction with earthquake, $((R+S)/2)$ operation, and $((R+S)/2)$ operation with earthquake cases, respectively. Factors of safety for the upstream face were 1.17 for the (Q) construction and 2.2 for the (S) operating cases. Settlement was evaluated and a total settlement of 0.9 feet was predicted. The structure was overbuilt to compensate. Underseepage was evaluated using a minimum Bligh's creep ratio ($C = L/H$) of 15 for a foundation composed of fine to medium sand as shown in EM 1110-2-1902. An upstream impervious blanket seven feet thick was constructed to lengthen the seepage path to 475 feet. The Geotechnical design of the closure dam is presented in Paragraph 3-09 of DM 28.

h. Upstream Approach Channel. Two representative sections were analyzed for the upstream channel. Calculations were performed using the computer program UTEXAS2. Minimum factors of safety of 1.46, 1.16, 1.82, 1.26, 1.70, and 1.46 were obtained for the (Q) operating, (Q) earthquake, (S) operating, (S) earthquake, (minimum R&S) sudden drawdown from flood, and (minimum R&S) sudden drawdown from normal operation conditions, respectively. All computed factors of safety exceeded minimum requirements.

i. Downstream Approach Channel. Two representative sections were analyzed for the downstream approach channel. Calculations were performed using the computer program UTEXAS2. Minimum factors of safety of 1.43, 1.15, 1.74, 1.20, 1.21 and 1.11 were obtained for the (Q) operating, (Q) earthquake, (S) operating, (S) earthquake, (minimum R&S) sudden drawdown from flood and (minimum R&S) sudden drawdown from normal operation conditions respectively. All computed factors of safety exceeded minimum requirements.

4-03. Backfill Drainage and Underslab Relief Systems.

a. General. There were two main drainage systems used to relieve excess hydrostatic pressures at Lock and Dam No. 4. These systems are described below and presented on Plates 9 through 14.

(1) Lock Wall Drainage System. The collector pipe and filter system behind the landside lock wall consists of an 8-inch PVC well screen, No. 10 slot, encapsulated by a layer of Filter Sand "B." The drainage system is used to lower hydrostatic pressures in the sand backfill and discharges at approximate elevation 96.0. Select sand backfill was recovered and stockpiled during excavation. Plates 9, 10, and 11 show the details of this system.

(2) Tainter Gate and Crested Gate Structures Underdrain System. The collector system beneath these structures consists of 6-inch stainless steel well screen, No. 20 Slot, within a 2-foot layer of Filter Gravel "C" underlain by a 6-inch layer of Filter Sand "B." The well screen is in a multiple loop configuration with an outlet into each of the dam piers. The system discharges into the stilling basin at approximate elevation 87.0. Plates 12, 13, and 14 show the general layout of this system.

b. Filter Design. The gradation limits specified for the filter materials in this contract were as required in D.M. No. 27, Lock and Dam Nos. 4 and 5, "Availability of Construction Materials, dated December 1989. The gradation limits and Quality Assurance test data are presented in Tables 4-1, 4-2, and 4-3. The gradation bands of the filter materials provided for this project are presented on Figure 4-1. The filter sand and gravel were processed by Madden Contracting Co. Inc., from the Raley Gravel Pit. The filter stone was processed from the Reed Crushed Stone Company, Inc., Gilbertsville Quarry, Gilbertsville, Kentucky. The three filter materials do meet the filter criteria specified in EM 1110-2-1901, Engineering and Design - Seepage Analysis and Control for Dam, dated 30 September 1986, as follows:

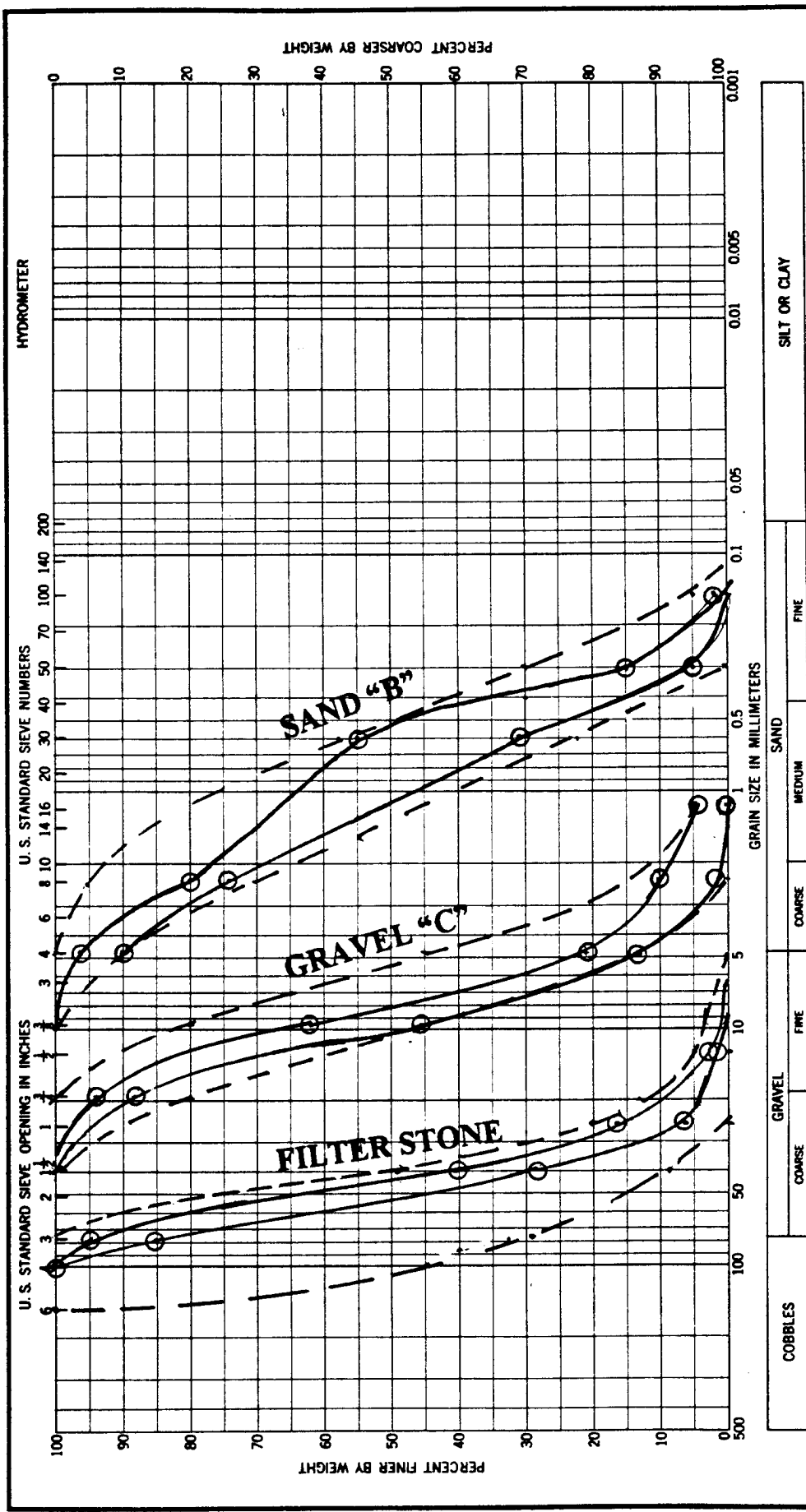

COBBLES		GRAVEL		SAND		SILT OR CLAY	
		COARSE		MEDIUM		FINE	
Classification		Nat w %		LL		PL	
PI							
Elev or Depth							
Sample No.							
LOCK AND DAM NO. 4				FILTER MATERIAL			
Project				Area			
Boring No.				Date			
GRADATION CURVES							

FIGURE 4-1

Sand "B" vs Gravel "C"

$$\frac{D_{15} \text{ Filter Gravel "C"}}{D_{85} \text{ Filter Sand "B"}} = \frac{5}{3} = 1.7 \leq 5; \text{ does meet piping ratio}$$

$$\frac{D_{15} \text{ Filter Gravel "C"}}{D_{15} \text{ Filter Sand "B"}} = \frac{3.6}{0.4} = 9 \geq 5; \text{ does have sufficient permeability}$$

$$\frac{D_{50} \text{ Filter Gravel "C"}}{D_{50} \text{ Filter Sand "B"}} = \frac{10.5}{0.5} = 21 \leq 25; \text{ does meet coefficient of uniformity}$$

Gravel "C" vs Filter Stone

$$\frac{D_{15} \text{ Filter Stone}}{D_{85} \text{ Gravel "C"}} = \frac{32}{14} = 2.3 \leq 5; \text{ does meet piping ratio}$$

$$\frac{D_{15} \text{ Filter Stone}}{D_{15} \text{ Gravel "C"}} = \frac{25}{5} = 5 \geq 5; \text{ does have sufficient permeability}$$

$$\frac{D_{50} \text{ Filter Stone}}{D_{50} \text{ Gravel "C"}} = \frac{55}{8} = 7.8 \leq 25; \text{ does meet coefficient of uniformity}$$

Filter Sand "B" vs Well Screen

$$\frac{D_{50} \text{ Sand "B"}}{10 \text{ Slot (.010 in.)}} = \frac{0.5}{.25} = 2 \geq 1.2; \text{ does meet piping ratio}$$

4-04. Channel Protection.

a. Stone Protection and Channel Protection. The stone protection and channel protection at Lock and Dam No. 4 were designed based on expected channel velocities at the structure, as presented in "Hydrology and Hydraulic Design, Lock and Dam No. 4," DM No. 23, dated 5 July 1978, and revised data included in "GDM Phase II, Project Design, Lock and Dam No. 3," DM No. 13 (Revised Edition), dated 18 April 1984. The stone protection consists of seven riprap gradations and the channel protection consists of two Graded Stone gradations. Plates 3, 4, 5, and 15 show the locations of the gradations used. A bedding layer was placed on impervious foundations and covered with riprap. Filter layer systems were placed on pervious foundations and then covered with riprap (Photographs 17 and 18). Engineering fabric (nonwoven geotextile) was also used beneath some riprap as a filter layer. The riprap and graded stone were produced at the Reed Crushed Stone Company, Inc., Gilbertsville Quarry, Gilbertsville, Kentucky, from a limestone formation.

b. Gradation Limits. The gradation limits and Quality Assurance test results for the various riprap sizes and graded stone are presented in Tables 4-4 through 4-12 and Figures 4-2 through 4-6. The gradation tests performed on the graded stone were performed following the LMVD Standard Test Method for Gradation of Riprap and Graded Stone.

c. Engineering Fabric. The engineering fabric for this contract was manufactured by Amoco Fabrics & Fibers Co. Atlanta, Georgia. There are no test data on the materials provided. The product names provided were Amoco 4510 for Grade 2 requirements and Amoco 4561 for Grade 1 requirements. Based on data included in "Geotechnical Fabrics Report", Industrial Fabrics Association International, December 1992, these geotextiles should have met the requirements of this project (Photograph 19).

d. Filter and Bedding Material Design. The gradation limits and Quality Assurance test data for Bedding Material are presented in Tables 4-13 and 4-14. The gradation bands of the bedding materials provided for this project are presented on Figures 4-7 and 4-8. The main criterion that needed to be met between the filter materials or bedding materials and the riprap is the piping ratio. Piping criteria were met for all materials.

Filter Stone vs R650 Riprap

$$\frac{D_{15} \text{ R650 Riprap}}{D_{85} \text{ Filter Stone}} = \frac{296}{65} = 4.6 \leq 5 \text{ does meet piping ratio}$$

Bedding Stone No. 1 vs R90 Riprap

$$\frac{D_{15} \text{ R90 Riprap}}{D_{85} \text{ Bedding Stone \#1}} = \frac{146}{63} = 2.3 \leq 5 \text{ does meet piping ratio}$$

Bedding Stone No. 2 vs R650 Riprap

$$\frac{D_{15} \text{ R650 Riprap}}{D_{85} \text{ Bedding Stone \#2}} = \frac{296}{89} = 3.3 \leq 5 \text{ does meet piping ratio}$$

R90 Riprap vs R7400 Riprap

$$\frac{D_{15} \text{ R7400 Riprap}}{D_{85} \text{ R90 Riprap}} = \frac{655}{208} = 3.2 \leq 5 \text{ does meet piping ratio}$$

e. Riprap and Graded Stone Produced on Site. At this project site a sandstone lense was encounter during site exploration and during excavation. After the stone was

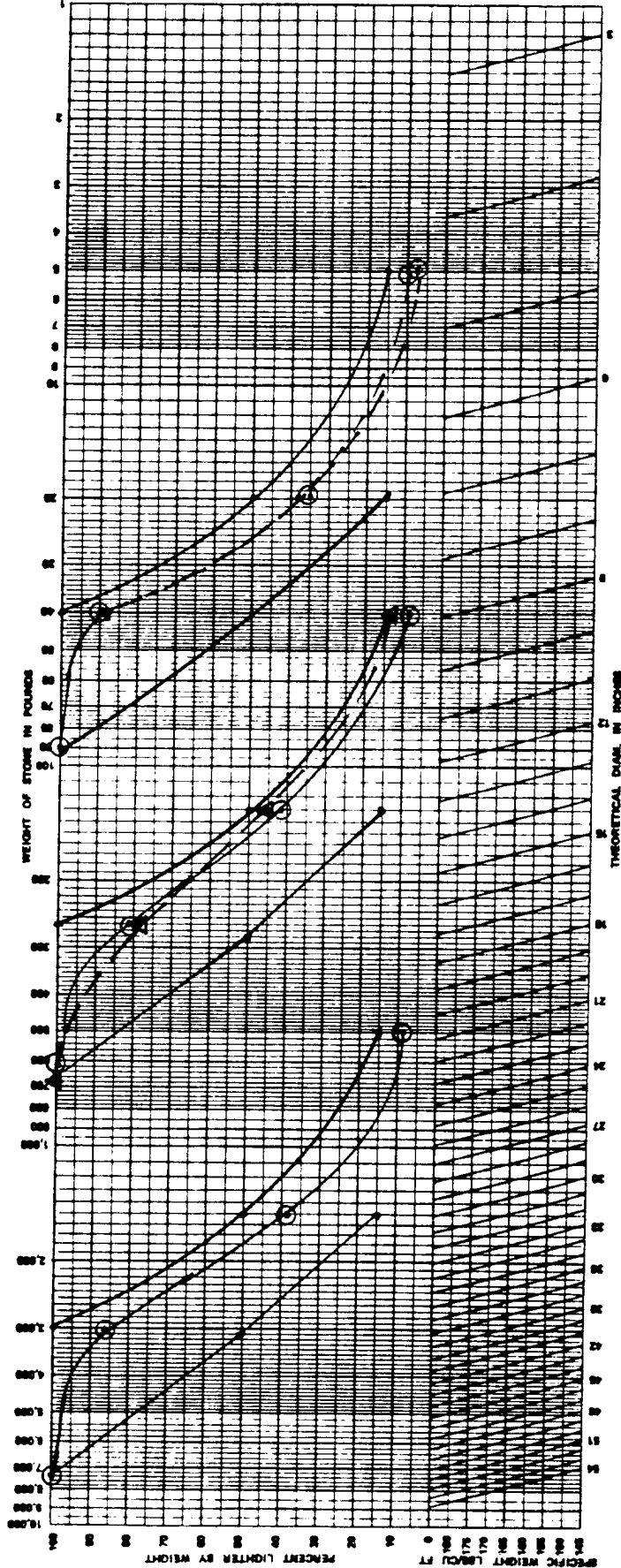

R 90, R 650, R 7400

SPECIFIC WEIGHT OF STONE 168 LBS/CU FT

PROJECT LOCK AND DAM NO. 4

AREA _____

DATE _____ BY _____

RIPRAP GRADATION CURVES

(Proponent: DAEN-CWE-HD)

FIGURE 4-2

ENG FORM 4794-R, Sep 82

(EM 11110-2-1601)

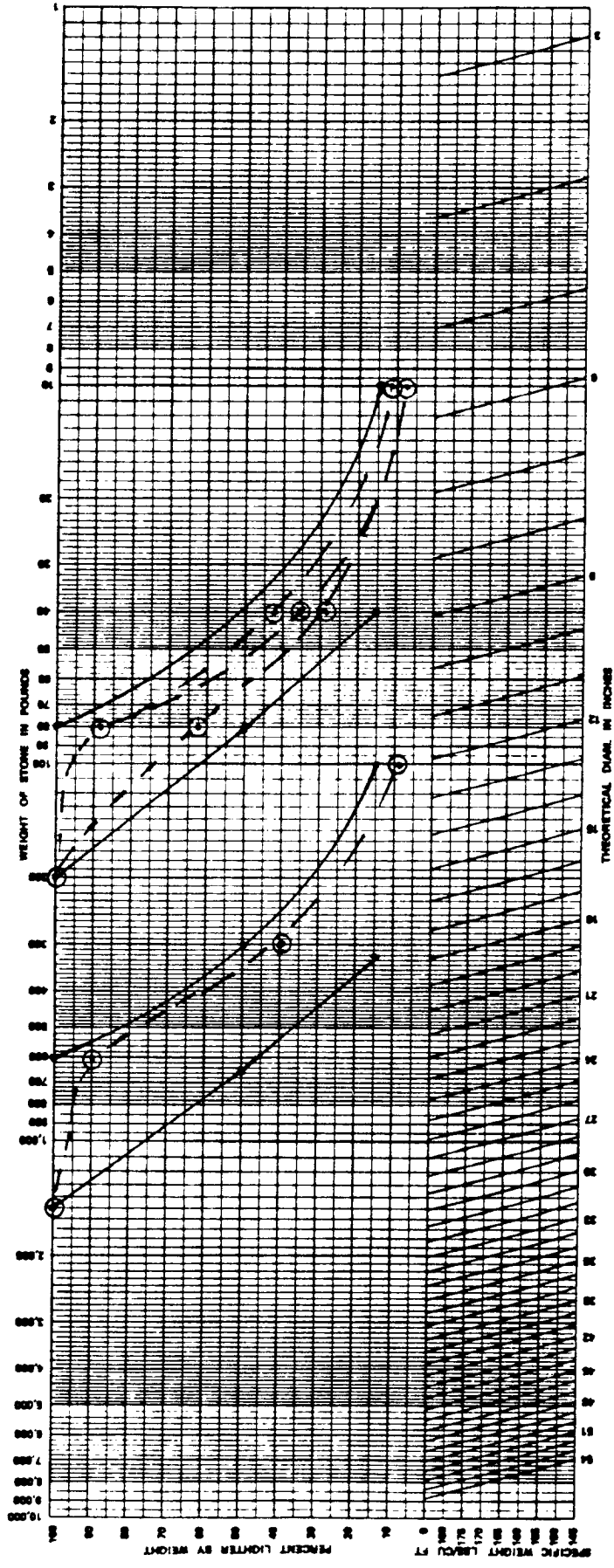

R200, R1500

SPECIFIC WEIGHT OF STONE 168 LBS/CU FT

PROJECT LOCK AND DAM NO. 4

AREA _____

DATE _____ BY _____

RIPRAP GRADATION CURVES

(Proponent: DAEN-CWE-HD)

(EM 1110-2-1601)

FIGURE 4-3

ENG FORM 4794-R, Sep 82

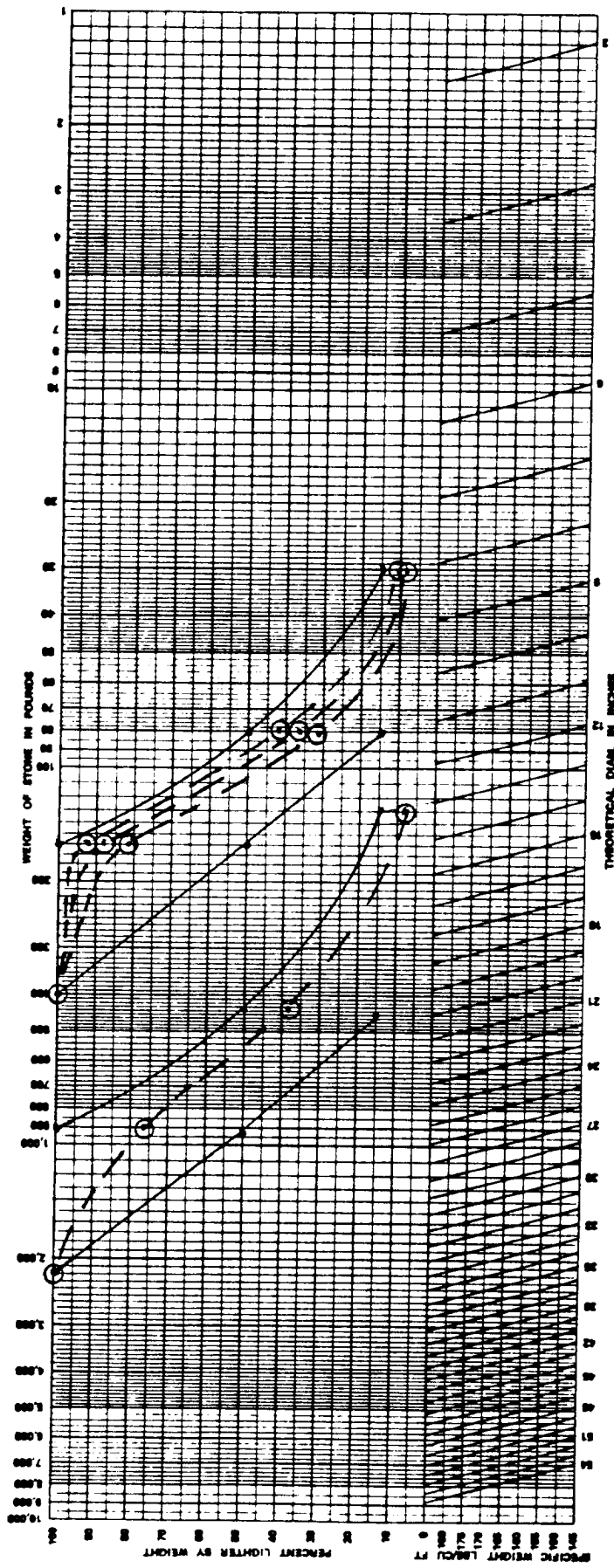

R400, R2200

SPECIFIC WEIGHT OF STONE 168 LBS/CU FT

PROJECT LOCK AND DAM NO. 4

AREA _____

DATE _____ BY _____

RIPRAP GRADATION CURVES

(EM 1110-2-1601) (Proponent: DAEN-CWE-HD)

FIGURE 4-4

ENG FORM 4794-R, Sep 82

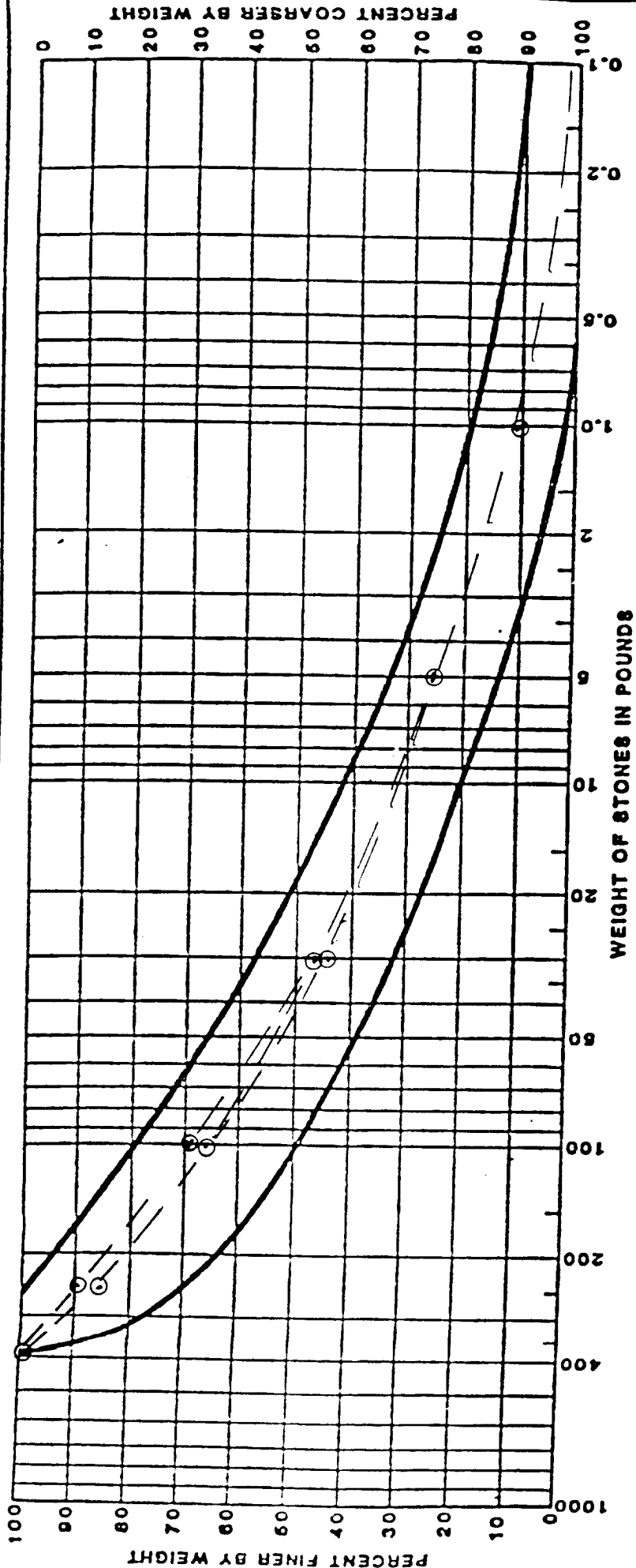

STONE WEIGHT POUNDS

CUMULATIVE % FINER BY WEIGHT

- 400
 - 250
 - 100
 - 30
 - 5
 - 1
 - less than 1/2" Sieve
- 100
 - 70-100
 - 60-80
 - 32-58
 - 15-34
 - 2-20
 - 0-10

NOTE: 5% of the material can weigh more than 400 pounds. However no piece shall weigh more than 500 pounds.

LOCK AND DAM NO. 4

GRADATION
GRADED STONE C

SEPTEMBER 1976

FIGURE 4-5

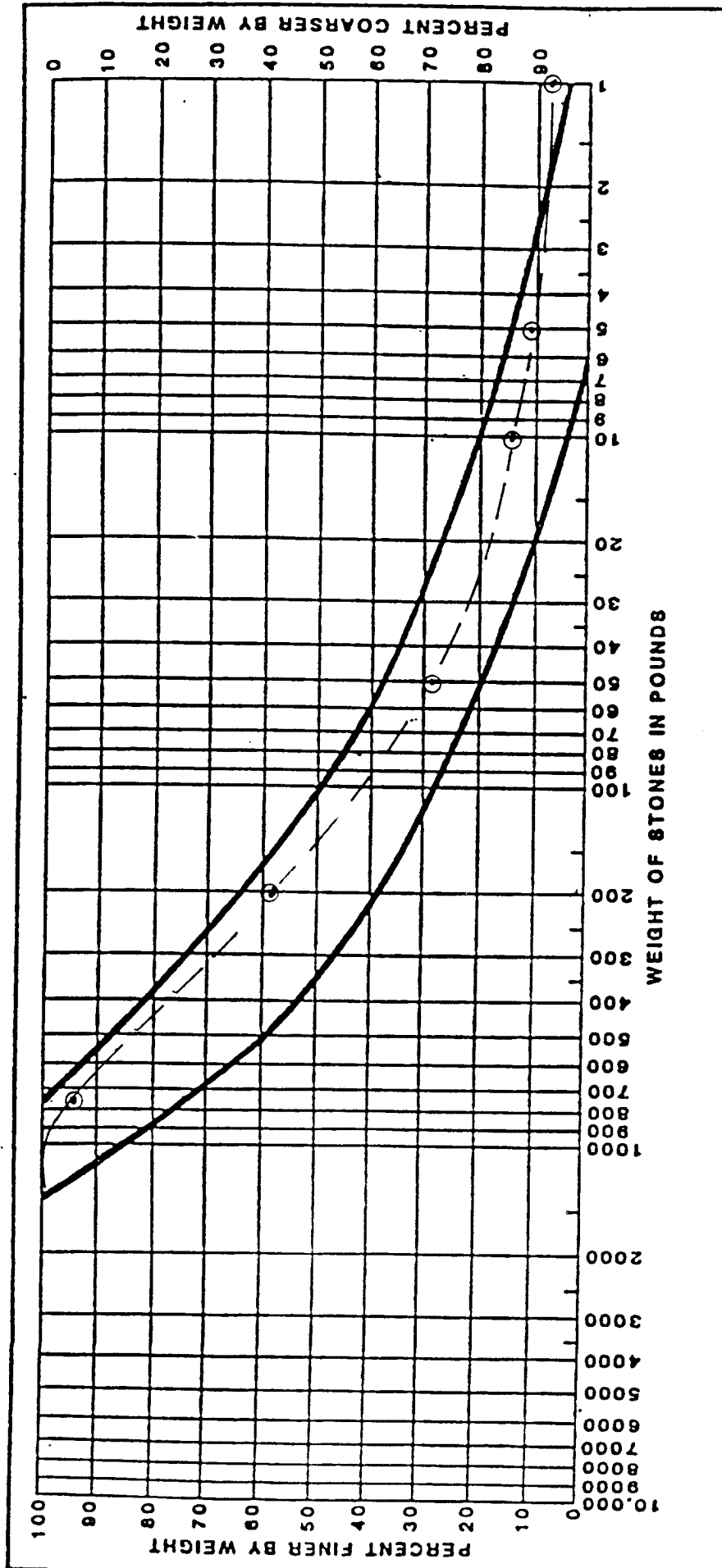

STONE WEIGHT POUNDS

- 1200
- 750
- 200
- 50
- 10
- 5
- 1

CUMULATIVE % FINER BY WEIGHT

- 100
- 72-100
- 40-65
- 20-38
- 5-22
- 0-15
- 0-6

LOCK AND DAM NO. 4

GRADATION

GRADED STONE B

MAY 1975

FIGURE 4-6

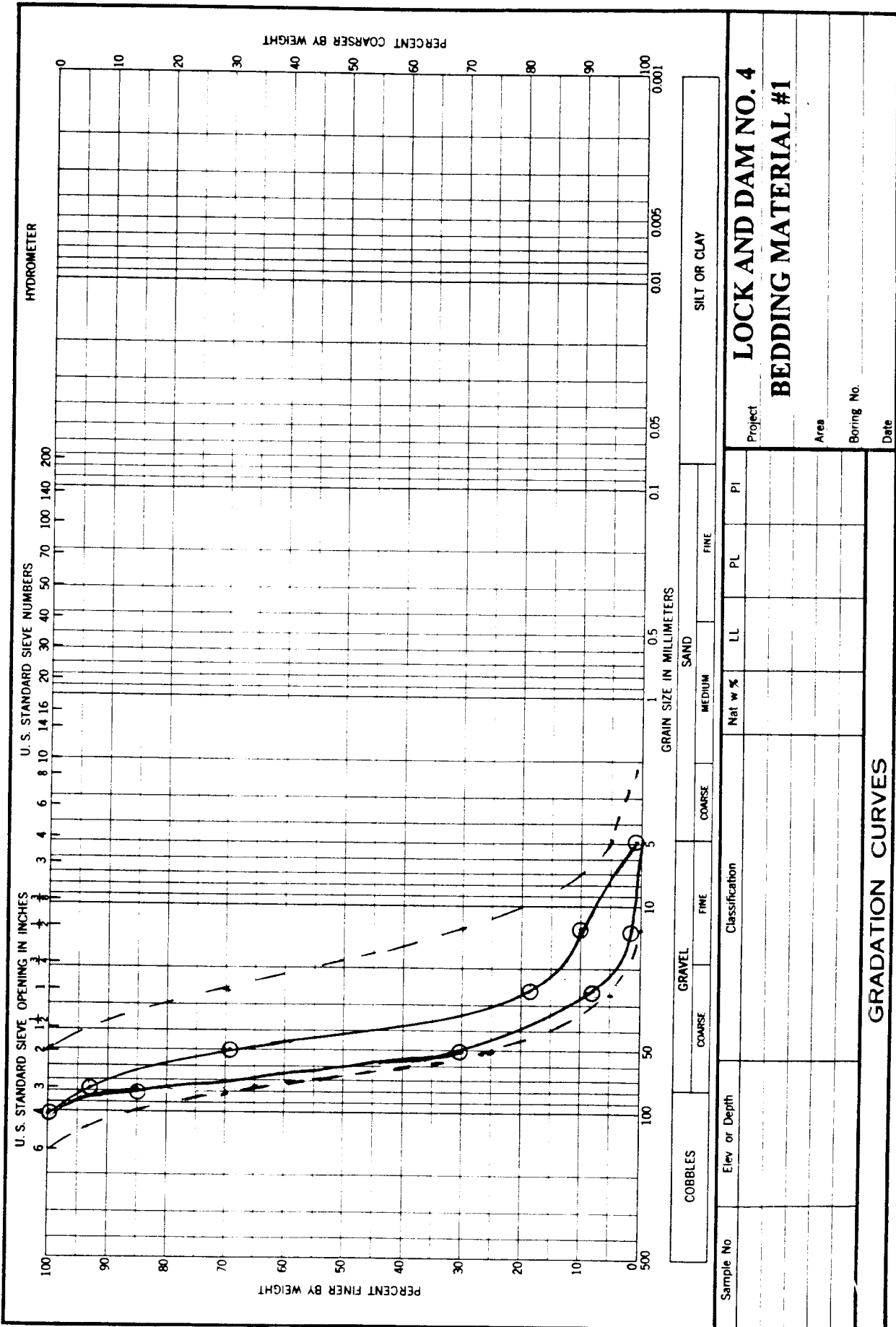

FIGURE 4-7

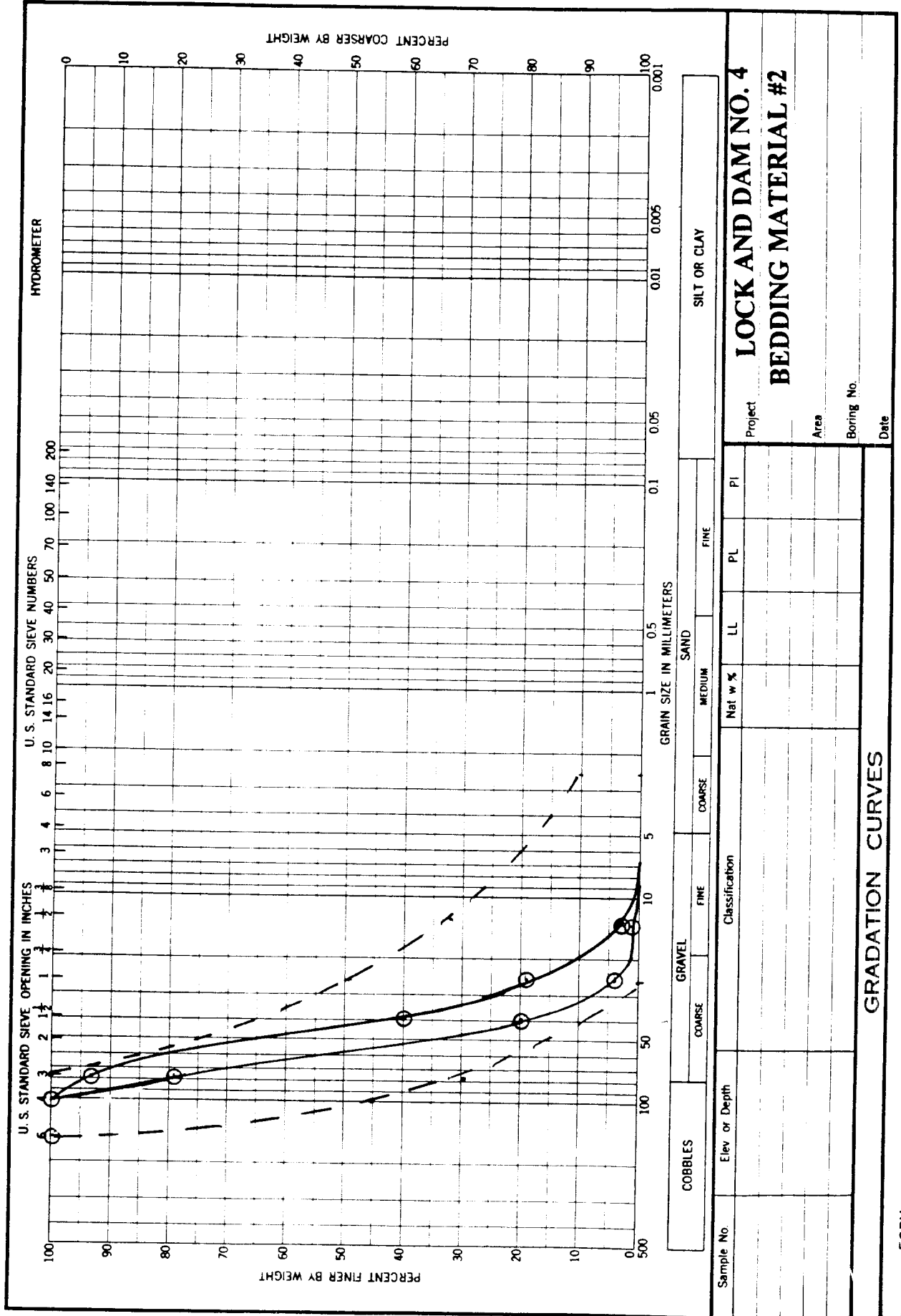

FIGURE 4-8

stockpiled the Contractor made a Value Engineering Proposal that the stockpiled material be manufactured into riprap and Graded Stone. The proposal was accepted and the stone was placed in the upper pool on the upstream slope of the closure dam. Graded Stone "B" was manufactured and placed in the upstream rock toe dike of the closure dam. R200 riprap was placed from Stations 119+00 to 130+00, and between 358 feet and 318 feet upstream of centerline of closure dam. R650 riprap was placed from Stations 119+00 to 130+00, and between 318 feet and 210 upstream of centerline of closure dam (Photographs 20 and 21). For a discussion of this change see Paragraph 8-03.

TABLE 4-1

Filter Sand "B"					
	Date	7/14/92	1/28/93	7/29/93	12/9/93
Specification		Percent Passing			
Sieve Size	Percent Passing				
3/8 inch	100	100	100	100	100
No. 4	90-100	97.2	93.2	90.3	91.4
No. 8	70-95	79.3	77.7	77.5	74.1
No. 30	22-57	43.9	49.9	52.7	31.1
No. 50	0-30	11.8	12.8	14.5	4.2
No. 100	0-5	1.6	1.4	2.0	.45

TABLE 4-2

Filter Gravel "C"					
	Date	4/29/92	7/16/92	7/29/93	12/13/93
Specification		Percent Passing			
Sieve Size	Percent Passing				
1-1/2 in	100	100	100	100	100
3/4 inch	80-100	91.6	94.2	92.8	89.3
3/8 inch	45-80	78.3	77.4	80.4	80.5
No. 4	13-45	14.7	20.8	17.1	22.1
No. 8	0-14	1.8	2.1	2.7	10.1
No. 16	0-5	1	.9	.6	8.1*
* Failed to meet gradation requirements					

TABLE 4-3

Filter Stone					
	Date	12/10/92	10/1/93	1/14/94	6/8/94
Specification		Percent Passing			
Sieve Size	Percent Passing				
6 inch	100	100	100	100	100
4 inch	45-100	100	100	100	100
3 inch	29-100	91	89	90	92
1-1/2 in	8-48	30	30	29	44
1 inch	0-20	10	9	6	16
1/2 inch	0-5	2	3	2	4

TABLE 4-4

R 90 Riprap				
	Date	1/27/93	12/2/93	1/14/94
Specification		Percent Finer by weight		
Stone Size (lbs)	% Finer by wt.			
90-40	100	90	89	90
40-20	50	35	37	38
20-5	15	9	10	11

TABLE 4-5

R 200 Riprap				
	Date	6/24/92	10/15/93	5/10/94
Specification		Percent Finer by weight		
Stone Size (lbs)	% Finer by wt.			
200-80	100	62	88	90
80-40	50	29	35	42
40-10	15	8	8	12

TABLE 4-6

R 400 Riprap					
	Date	6/7/92	6/12/92	6/22/92	8/26/94
Specification		Percent Finer by weight			
Stone Size (lbs)	% Finer by wt.				
400-160	100	88	81	85	90
160-80	50	36	31	29	40
80-30	15	9	7	9	9

TABLE 4-7

R 650 Riprap					
	Date	5/24/92	12/4/92	1/28/93	1/28/94
Specification		Percent Finer by weight			
Stone Size (lbs)	% Finer by wt.				
650-260	100	81	79	80	87
280-130	50	41	39	38	41
130-40	15	9	9	9	10

TABLE 4-7 (continued)

R 650 Riprap					
	Date	12/10/93*			
Specification		Percent Finer by weight			
Stone Size (lbs)	% Finer by wt.				
650-260	100	98.3			
280-130	50	54.7			
130-40	15	13.4			

* Test performed on stone manufactured from onsite stockpile.

TABLE 4-8

R 1500 Riprap				
	Date	1/27/93		
Specification		Percent Finer by weight		
Stone Size (lbs)	% Finer by wt.			
1500-600	100	90		
650-300	50	40		
330-100	15	9		

TABLE 4-9

R 2200 Riprap				
	Date	12/2/93		
Specification		Percent Finer by weight		
Stone Size	% Finer by wt.			
2200-900	100	76		
930-440	50	39		
460-130	15	9		

TABLE 4-10

R 7400 Riprap					
	Date	3/25/93	12/2/93	5/20/94	
Specification		Percent Finer by weight			
Stone Size (lbs)	% Finer by wt.				
7400-3000	100	86	85	81	
3100-1500	50	396	41	39	
1500-500	15	9	10	9	

TABLE 4-11

Graded Stone C					
Date		11/23/92	3/17/93	6/7/93	6/24/93
Specification		Percent Finer by weight			
Stone Size (lbs)	% Finer by wt.				
400	100	100	100	100	100
250	70-100	95	90	89	90
100	50-80	67	69	68	69
30	32-58	47	47	45	44
5	15-34	26	27	26	24
1	2-30	10	14	13	14
Less than 1/2" sieve	0-10	2	3	3	4

NOTE: 5% of the material can weight more than 400 pounds.
However no piece shall weigh more than 500 pounds.

TABLE 4-12

Graded Stone B					
Date		9/11/93*			
Specification		Percent Finer by weight			
Stone Size (lbs)	% Finer by wt.				
1200	100	100			
750	72-100	95.1			
200	40-65	58.9			
50	20-38	29.1			
10	5-22	15.7			
5	0-15	11.9			
1	0-5	8.2			

* Test performed on stone manufactured from onsite stockpile.

TABLE 4-13

Bedding Material No. 1					
	Date	6/9/92	8/7/93	11/5/93	6/24/94
Specification		Percent Passing			
Sieve Size	Percent Passing				
4 inch	100	100	100	100	100
3 inch	70-100	87	91	89	89
2 inch	25-100	43	42	64	50
1 inch	5-70	8	15	17	8
1/2 inch	0-30	2	6	4	3
No. 4	0-5	1	2	2	1

TABLE 4-14

Bedding Material No. 2					
	Date	6/4/91	1/8/93	5/24/94	10/19/94
Specification		Percent Passing			
Sieve Size	Percent Passing				
6 inch	100	100	100	100	100
4 inch	45-100	100	100	100	100
3 inch	29-100	86	93	87	81
1-1/2 in	8-48	23	16	40	17
1 inch	0-20	6	11	15	9
1/2 inch	0-5	3	2	3	4

SECTION V - EXCAVATION PROCEDURES

5-01. Excavation Grades. Excavation for the lock and dam extended through the Pleistocene Terrace and into the underlying Tertiary sediments of the Wilcox Group. Founding elevations range from 49.0 feet beneath the gated dam to 59.5 and 55.5 feet beneath the upper and lower lock gate bay monoliths, respectively. The stilling basin is founded at elevation 51 and the lock chamber is founded at elevation 62.5 (Photograph 22). The excavation plan is shown on Plate 6. Backfill plans and sections for the lock and the dam are shown on Plates 9 through 14.

5-02. Dewatering Provisions. Dewatering provisions for Lock and Dam No. 4 included requirements to accomplish the following:

- a. Unwatering the initial excavation.
- b. Lower the water table 5 feet below excavation grade.
- c. Relieve hydrostatic pressure in any pervious strata in the Tertiary Formation to a point below the excavation grade.
- d. Collect and dispose of all surface water within the protected area.
- e. Install and monitor construction piezometers and
- f. Rewater the site at the completion of work.

The system employed by the Contractor consisted of a deep well system, three slurry trench cut offs to block seepage through the Holocene and Pleistocene aquifers, a wellpoint system to lower piezometric pressures in the Tertiary in the gated dam area, a french drain to collect seepage through the alluvium, and a piezometer system to monitor pressures in the Holocene and Tertiary aquifers. Surface water collection was accomplished using a system of top bank ditches and sumps and a number of temporary sumps within the excavation.

5-03. Overburden Excavation. The excavation for the Lock and Dam No. 4 project was performed under two separate contracts. The initial excavation was performed under a "Phase 1" contract and extended to elevations 57 beneath the gated dam, 69 beneath the lock, and 80 in the downstream channel. Total excavation consisted of approximately 8.6 million cubic yards. The initial earthwork was performed by Southwind Construction Corp. under contract number DACW38-90-C-0071. The structural excavation under the initial contract (within the protected area) was performed using one Hitachichi shovel and one Hitachichi backhoe.

Each excavator had a 13 yard bucket. Excavated materials were transported using 100 ton Euclid trucks or 85 ton Caterpillar trucks. Fine grading was performed under the main contract using small bulldozers and backhoes. Excavation for the approach channels was performed by Pine Bluff Sand and Gravel using a cutterhead dredge (Photograph 23). In addition, landbased scrapers, operated by Hill Brothers, were used in the upstream and downstream channels to recover reusable materials and excavate impervious and random materials above elevation 90. No dewatering was performed in the approach channels. Draglines and bulldozers were used for bank grading operations. Excavation for the channels totaled 4,957,462 cubic yards of which 2,033,996 were removed using landbased equipment and 2,923,466 were removed using a cutterhead dredge. The excavation plan for the structure is shown on Plate 6.

5-04. Dewatering System. Griffin Dewatering Company was responsible for construction dewatering and surface water control at Lock and Dam No. 4 under the Phase 1 contract. Dewatering was accomplished using a combination of deep wells, slurry trenches and french drains. This initial dewatering system consisted of 18 deep wells (numbers 1 through 18) installed at the natural ground surface and extending into the Tertiary formation (near elevation -20). Individual wells were constructed of 8 inch, schedule 160 PVC pipe with an 8 inch, 0.032 slot well screen surrounded by filter gravel "E". Three slurry trenches, ranging from 15 to 34 feet in depth, were constructed to block seepage through the Quaternary aquifers. Ten gravel filled ditches (referred to as "French drains") were constructed to drain off seepage that emerged on the excavation side slopes along the Tertiary-alluvial interface. The phreatic surface in both the Tertiary and alluvial aquifers was monitored using the existing COE piezometers. As excavation approached elevation 57 (final grade in the gated dam area) the Phase 1 contractor installed a vacuum wellpoint system to achieve sufficient drawdown in the Tertiary aquifer. Surface water was collected and controlled using a system of more or less permanent sumps and pumps located on the top bank of the excavation and supplemented with temporary sumps which were relocated as the excavation progressed. This system was turned over to the Phase II contractor at the completion of the Phase I item of work. During the Phase II contract the dewatering item was handled by Fugro - McClelland. Under their direction the existing system was supplemented in the following manner. Wells 19 and 20 were installed on the elevation 90 bench adjacent to the upstream lock monolith (L-1), wells 21 through 23 were installed on the elevation 90 bench in the vicinity of the overflow wall, wells 24 and 25 were installed downstream of the stilling basin and wells 26 through 31 were installed around the gated dam foundation. The above listed wells (numbers 19 to 31) were 4 inches in diameter and intended primarily to lower piezometric levels in the Tertiary aquifer. (All Phase II excavation within the protected area involved

Tertiary materials.) Wells 26 through 31 failed to adequately lower the pressures in the confined Tertiary strata and Frugro-McClelland re-installed the wellpoint system which Griffin Dewatering had install in the Phase I dewatering effort. Frugro-McClelland also added 8 construction piezometer (P-17, PS-17, P-18, PS-18, P-19, PS-19, P-20 and PS-20). Surface water control consisted of maintaining and operating the existing (Griffin installed) system of topbank perimeter ditches, topbank sumps, topbank dikes and temporary sumps with sump pumps inside the excavation. This surface water control system was modified on an ad hoc basis and on several occasions it failed to keep up with rainfall events and caused minor damage to the work area. The dewatering system was operated on an "as needed" basis, especially when the excavation was complete, and no attempt has been made to summarize the performance of the system. No significant problems occurred with the dewatering item of work. For a complete layout of the system, see Plate 16. Photographs 24 through 26 show details of the dewatering system.

SECTION VI - CHARACTER OF THE FOUNDATION

6-01. Foundation Surfaces of Each Component. Lock and Dam No. 4 is founded on clay(stone), silty sand and sandstone of the Wilcox Group (Undifferentiated). Final grade excavation for the lock, dam, guidewalls, and cutoff wall extended through the Quaternary sediments and into the Tertiary deposits of the Wilcox Group (Plates 17 and 18). Foundations for the upstream return wall and downstream return wall sloped upward and are founded partially on Tertiary materials and partially on alluvial materials (although all return wall foundations contain a variable thickness of fully compacted pervious materials beneath their bases). The crest gated spillway and the overflow wall are founded on variable thicknesses of fully compacted pervious material (final grade excavation beneath these structures extended into Tertiary materials). The gated dam and associated stilling basin contained a two stage pressure relief/drainage system on top of the Tertiary foundations. Tertiary foundations were quite variable although they consisted mostly of fine, gray, silty sand (SM, SP-SM) with lenses or strata of dark gray to black Tertiary clay (CH-CL) or "claystone". These hard Tertiary clays are referred to as claystone to emphasize their great difference with the Quaternary alluvial clays. The stress history of these Tertiary materials indicates that they were deeply buried in the geologic past and are highly over-consolidated. As a result they exhibited virtually no strain when subjected to the loads (stresses) associated with the lock and dam (i.e. settlement is not a problem on this foundation as discussed in Paragraph 4-02e). The "claystone" is not competent rock like the sandstone and siltstone found on this job site. (Clay strata actually turned to rock would be designated as shale). They differ from the sandstone and siltstone in their high susceptibility to weathering, density, tensile strength, and shear strength. (A good example of this difference is shown on Photograph 10) The sandstone and siltstone that were found in the Tertiary formation occurred as lenses or beds ranging up to 10 feet in thickness. The sandstone was fine grained, gray, very hard, dense, and contained minor lignite deposits (as did the entire Tertiary section examined in the field). Sandstone interfered with final grade excavation or actually formed the foundation for structural components in the gated dam and stilling basin, upstream guardwall, upstream return wall and downstream return wall.

6-02. Condition of the Foundation.

a. Dam. The gated dam and stilling basin were constructed on an underdrain system which rests on a Tertiary foundation as shown on Plates 6, 12, 13, 14, 17, and 18. The cutoff wall, crest gated spillway (Monolith D-5), and overflow wall were constructed on varying thicknesses of fully compacted pervious sand backfill which, in turn, rests on a Tertiary

foundation (Photograph 27). As can be seen on Plates 12 through 14 the backfill beneath the cutoff wall ranged from 1 to 3 feet. Backfill beneath the crest gated spillway ranged from 2.5 feet to 26 feet. Backfill beneath the overflow wall ranged from 0.5 foot (beneath Monolith OW-1) to approximately 21 feet (beneath Monolith OW-3). Minor areas of sandstone were present at final grade. These outcrops were left in place. Contaminated material was removed and replaced with compacted pervious backfill.

b. Lock. The lock and guidewalls are founded on Tertiary sand and silty sand (SP, SP-SM). Final grade for these components is shown on Plates 9, 10, and 11. In all cases contaminated or unsuitable materials were removed and replaced with compacted select sand. Tertiary rock was encountered near final grade in the lock foundation. In all cases, except the downstream return wall, the rock was removed. The founding elevation for the downstream return wall was adjusted upward to allow a bed of hard, gray sandstone to remain in place (see Sections I-I and J-J on Plate 11).

6-03. Water Problems. Water problems on this project occurred with surface water control and Tertiary pressure relief. Failure to control surface water resulted in minor erosion to the excavation side slopes which required repeated repairs. In many locations the contractor opted to cover exposed Quaternary sands with a veneer of clay material to prevent erosion. Excavation in the gated dam area was delayed when the contractor's dewatering wells (4 inch diameter wells, numbers 26 to 31) failed to lower Tertiary pressures. The contractor alleged changed conditions and drilled six exploratory borings to investigate the subsurface conditions. The investigation failed to identify any problems and the necessary draw down was subsequently achieved using wellpoints on 2 foot centers (the same technique successfully used by Griffin Dewatering in Phase I).

6-04. Foundation Materials Mapped. Six identifiable and mappable units were described in the exploration phase for Lock and Dam 4. These units are (from oldest to youngest) the Tertiary Wilcox Group (undifferentiated), The Pleistocene Prairie Terrace substratum and topstratum units, the Holocene substratum and two Holocene topstratum units, point bar and abandoned channel. Three of these geologic units have been mapped in the current report. They are the Wilcox (designated as TW), the Pleistocene Prairie Terrace substratum (designated as PS), and the Pleistocene Prairie Terrace topstratum (designated as PT). An attempt was made to identify individual rock strata (designated as Rx) within the Wilcox units based on preconstruction borings and field investigations (Plates 17 and 18 and Table 6-1). It should be expected that competent rock exists that was not identified in this process. The Holocene units mentioned above did have a minor impact on the dewatering item. Holocene alluvium was also present in the access channels,

disposal areas, along the permanent access road alignment, and did provide significant sources of backfill borrow. However, Holocene materials are not involved in any structural foundation areas and were removed in the access channel excavations and therefore are considered beyond the scope of this report. Information on the extent and nature of the Holocene alluvium is available in Design Memorandum 28 "Detailed Design", Volumes I and IV.

TABLE 6-1
 LOCK AND DAM NO. 4 FOUNDATION SAMPLES
 (Samples collected at final grade during the period October 1992 through February 1993)

NO.	STRATUM	ELEVATION	LOCATION	STATION	DESCRIPTION
1.	TERTIARY	59.5	UPSTREAM LOCK GATE	0+00L, 0+00D	SAND (SP), FINE, BR, GR
2.	TERTIARY	62.5	CENTER LOCK CHAMBER	4+00L, 0+00D	SAND (SP-SM), GR, W/CS
3.	TERTIARY	55.5	DOWNSTREAM LOCK GATE	8+00L, 0+00D	SAND (SP), FINE, GR, BR
4.	TERTIARY	49.0	GATED DAM	0+00L, 1+00D	SAND (SP), FINE, GR, W/CS
5.	TERTIARY	49.0	GATED DAM	0+00L, 2+00D	SAND (SP), FINE, GR
6.	TERTIARY	49.0	GATED DAM	0+00L, 3+00D	SAND (SP), GR, BR, W/CS
7.	TERTIARY	49.0	GATED DAM	0+00L, 4+00D	SAND (SP), GR, BK, W/CS
8.	TERTIARY	51.0	STILLING BASIN	1+50L, 2+00D	SAND (SP-SM), FINE, GR, BR
9.	TERTIARY	51.0	STILLING BASIN	1+50L, 3+00D	SAND (SP), FINE, GR
10.	TERTIARY	51.0	STILLING BASIN	1+50L, 4+00D	SAND (SP-SM), FINE, GR

NOTE: FOR LOCATION OF FOUNDATION SAMPLES SEE PLATE 16.

SECTION VII - FOUNDATION TREATMENT

7-01. Drainage Provisions. Two drainage system have been incorporated into the lock and dam as discussed below. In addition, the foundations for the crest gated spillway and the overflow wall were constructed using select sand backfill processed on site from dredged river sand (Photograph 28).

a. Underslab Drainage System. The foundation beneath the gated dam and stilling basin contains a two stage pressure relief/underseepage collector system as shown on Plates 19 through 22. The system consists of a filter sand layer placed on the foundation overlain by a second stage filter composed of washed gravel (filter gravel "C") (see Photographs 29, 30, and 31). Stainless steel collector pipes evacuate seepage and discharge excess hydrostatic pressures to tailwater at approximately elevation 87.0 (Photographs 32 through 35). For a discussion of design and construction of the underslab filter system please see Paragraph 4-03 Backfill Drainage and Underslab Relief Systems.

b. Backfill Drainage System. Backfills left and right of the lock chamber were designed with three zones; a select sand adjacent to the lock wall, a pervious fill zone and a random fill zone as shown on Plates 9, 10, 11, and 23. The backfill adjacent to the lock on the landside contains a collector system which is encapsulated in a filter sand "B" and discharges to tailwater at approximate elevation 96.0. Minor design modifications and construction changes occurred to the backfills as discussed in Paragraphs 8-02. For a complete discussion of the design of the backfill drainage system, please see Paragraph 4-03, Backfill Drainage and Underslab Relief Systems.

7-02. Sheet pile. Sheet pile was installed in numerous locations beneath the lock and dam. The foundations for the overflow wall, crest gated spillway, stilling basin for the crest gated spillway, gated dam, stilling basin, and cutoff wall are surrounded by sheetpile cutoffs on all four sides (with adjacent structures sharing a common sheet pile line). The sheet pile cutoff driving line continues beneath the upstream gate bay of the lock, upstream approach monolith, upstream guard wall and upstream return wall. A second sheetpile line was installed beginning on the riverside of the downstream approach monolith (L-18) and continuing beneath the downstream return wall. In addition, the pier footings for the upstream and downstream guidewalls are individually encapsulated within sheet pile "cells". The upstream sheet pile line beneath the lock and dam forms a positive seepage cutoff. Sheet piling installed beneath the downstream approach monolith (L-18), downstream return wall and the guidewalls is an erosion control measure intended to protect these foundations. Locations and depths of the sheet

piling are shown on Plates 24 and 25. Minor problems were experienced with sheet pile penetration along the right side of stilling basin monolith SB-5, on the driving line on the upstream face of gated dam monolith D-1 and beneath the upstream and downstream return walls. Essentially, the presence of rock below final excavation grade prevented the installation of some of the sheet pile to design depth. In the above mentioned areas the driving operation was stopped when penetration was no longer possible (refusal) and the sheet pile was cut off at that point. For a detailed discussion of those areas where rock interfered with the sheetpiling see Paragraph 8-01 (Photographs 36 and 37).

7-03. Instrumentation. The instrumentation package at Lock and Dam No. 4 consists of reference bolts, piezometers, and settlement plates. The location and details of these instruments are shown on Plates 26 through 31. The permanent piezometers are shown in Photographs 34 and 38.

SECTION VIII - CHANGES FROM DESIGN

8-01. Tertiary Rock. The Tertiary formations present beneath the Holocene alluvium at the site are part of the Wilcox Group. This group of formations was deposited along an aggrading shoreline during the Eocene Epoch. Lithologies that result from these kinds of environments of deposition are quite variable and can change radically over short distances. Consequentially, the soil types present in the Tertiary at Lock and Dam No. 4 vary from clay to silt to sand and the contact between pervious and impervious soil types is often sharp and abrupt. Changes occur both laterally and vertically and in a quite random way. In those instances when a sand body (or pervious stratum) extends for a great continuous length or interconnects with other "pervious channels" forming an extensive network for ground water migration, there exists the possibility that mineral deposition within the pore channels will result in diagenesis. Diagenesis, in this case, refers to the process of making hard, competent rock from sediments by cementing the individual grains into a rock mass. The Tertiary sediments at the construction site displayed several extensive rock "beds". In general, the exposed rock "beds" trend parallel (or subparallel) to the lock centerline (Photograph 39). Individual rock deposits were traceable over distances in excess of 1000 feet. Furthermore, the rock's location in the subsurface could be forecast by extrapolating its trend and its presence was often confirmed by boreholes, water wells, and/or sheet pile installations. It should also be noted that rock was often encountered where it was not expected and it occasionally pinched out. As noted above, the rock developed as ground water transporting "channels" of some length rather than isolated lenses or small pockets. It was further noted that not all high permeability sand was lithofied. In fact, only a small percentage of the Tertiary sand present was altered. When the rock existed above final grade it was generally removed. When encountered below final grade, or when removal would have forced the contractor to exceed final grade, the rock was often left in place. Affected areas are outlined below.

a. Stilling Basin and Gated Dam. Rock below final excavation grade prevented driving all of the sheetpiling along the outside edge of monolith SB-5 and the sheet pile line between gated dam monoliths D-4 and D-5 to final grade. At SB-5 30 (of 124) sheet piles met refusal above final grade and 127 linear feet of sheetpiling were cut off (an average of about 4 feet per cut pile). Along the upstream face of the gated dam (Monolith D-4) approximately 43 linear feet of sheetpiling were cut between pile No. 130 and No. 160 (Photograph 37). All cut piling had been driven to refusal and the competent rock encountered will provide adequate blockage for under seepage.

b. Upstream Guardwall. Approximately 2 feet of rock were removed from the foundation of the upstream guardwall to allow for the installation of the sheet pile cut-off. The rock

was located below final grade and was removed by excavating a shallow trench with a backhoe along the alignment (Photograph 40).

c. Upstream Return Wall. The sheet pile beneath the upstream return wall encountered rock near final grade. The sheet piles were driven through the rock except in an area 6 to 8 feet long near the middle of the run where the sheet pile were driven to refusal and cut.

d. Downstream Return Wall. A large outcrop of hard intact rock was present at final grade beneath the downstream return wall. (The base of the return wall is constructed on a pervious backfill placed above final grade.) In this area the sheetpiling was driven through the backfill and "keyed" into the rock mass. Portions of this same rock stratum were removed beneath parts of the lock chamber and the lower gate bay. The rock had proven to be extremely hard and up to 8 feet thick. Removing the rock beneath the downstream return wall would not have improved the foundation because impervious rock would have been replaced with pervious fill which was considered an inferior seepage barrier and foundation material (Photograph 41).

e. Rock Remaining in Riverside Backfill. As noted in (d) above, a large rock "shelf" was present in the downstream area of the lock. This rock sheet was located 3 to 6 feet above final grade. Where the rock was present in the area intended for random backfill (channel side of the lock), the Contractor was allowed to leave it "in place" (Photograph 39). This change substituted rock for random backfill.

8-02. Changes in Backfill Materials. The design of Lock and Dam No. 4 envisioned using pervious materials from the channel excavations to construct free draining backfill left and right of the lock chamber. However, severe erosion occurred in the upstream approach channel as a result of the Piermont Revetment (and channel realignment) (Photograph 42). Six to eight hundred feet of bank caving occurred. This proved a mixed blessing. Less channel excavation was required; however much of the eroded materials were scheduled for reuse in the backfills. As a result of this "short fall", the government diminished the size of the pervious backfill areas and allowed the contractor to substitute a random class of material in those areas shown on Plates 9, 10, and 11.

8-03. Reuse of excavated Tertiary Rock as Riprap. As a result of a contractor VE proposal, Tertiary sandstone was reused as protection stone on this job. Tertiary sandstone was processed to provide R650 and R200 riprap, and Graded Stone "C" (Photographs 20 and 21). These materials were used as channel protection below the water line in the upstream channel and on

the upstream face of the closure dam (Plates 3 and 32). For a more detailed discussion of this change see Paragraph 4-04, Channel Protection.

8-04. Backfill Collector System Manholes. The Contractor substituted 60 inch, pre-cast sewer pipe for the cast-in-place concrete manholes that service the backfill drainage collector system. Ladders and access covers are the same as originally designed. These changes are shown on Plate 23. Photos 43 and 44 show the as-built manholes.

SECTION IX - POSSIBLE FUTURE PROBLEMS

9-01. Backfill Collector System. The backfill collector system landslide of the lock chamber will collect and discharge seepage that infiltrates the backfill from the Pleistocene terrace aquifer and the Tertiary aquifer (Plates 10 and 11). The collector system will also drain ground water that infiltrates from the topographically higher hill country north and east of the Red River alluvial valley. These sources are known to contain water high in iron and other dissolved solids that may precipitate and block the openings of the collector pipes.

was located below final grade and was removed by excavating a shallow trench with a backhoe along the alignment (Photograph 40).

c. Upstream Return Wall. The sheet pile beneath the upstream return wall encountered rock near final grade. The sheet piles were driven through the rock except in an area 6 to 8 feet long near the middle of the run where the sheet pile were driven to refusal and cut.

d. Downstream Return Wall. A large outcrop of hard intact rock was present at final grade beneath the downstream return wall. (The base of the return wall is constructed on a pervious backfill placed above final grade.) In this area the sheetpiling was driven through the backfill and "keyed" into the rock mass. Portions of this same rock stratum were removed beneath parts of the lock chamber and the lower gate bay. The rock had proven to be extremely hard and up to 8 feet thick. Removing the rock beneath the downstream return wall would not have improved the foundation because impervious rock would have been replaced with pervious fill which was considered an inferior seepage barrier and foundation material (Photograph 41).

e. Rock Remaining in Riverside Backfill. As noted in (d) above, a large rock "shelf" was present in the downstream area of the lock. This rock sheet was located 3 to 6 feet above final grade. Where the rock was present in the area intended for random backfill (channel side of the lock), the Contractor was allowed to leave it "in place" (Photograph 39). This change substituted rock for random backfill.

8-02. Changes in Backfill Materials. The design of Lock and Dam No. 4 envisioned using pervious materials from the channel excavations to construct free draining backfill left and right of the lock chamber. However, severe erosion occurred in the upstream approach channel as a result of the Piermont Revetment (and channel realignment) (Photograph 42). Six to eight hundred feet of bank caving occurred. This proved a mixed blessing. Less channel excavation was required; however much of the eroded materials were scheduled for reuse in the backfills. As a result of this "short fall", the government diminished the size of the pervious backfill areas and allowed the contractor to substitute a random class of material in those areas shown on Plates 9, 10, and 11.

8-03. Reuse of excavated Tertiary Rock as Riprap. As a result of a contractor VE proposal, Tertiary sandstone was reused as protection stone on this job. Tertiary sandstone was processed to provide R650 and R200 riprap, and Graded Stone "C" (Photographs 20 and 21). These materials were used as channel protection below the water line in the upstream channel and on

the upstream face of the closure dam (Plates 3 and 32). For a more detailed discussion of this change see Paragraph 4-04, Channel Protection.

8-04. Backfill Collector System Manholes. The Contractor substituted 60 inch, pre-cast sewer pipe for the cast-in-place concrete manholes that service the backfill drainage collector system. Ladders and access covers are the same as originally designed. These changes are shown on Plate 23. Photos 43 and 44 show the as-built manholes.



1. Completed structure.



2. Completed structure.

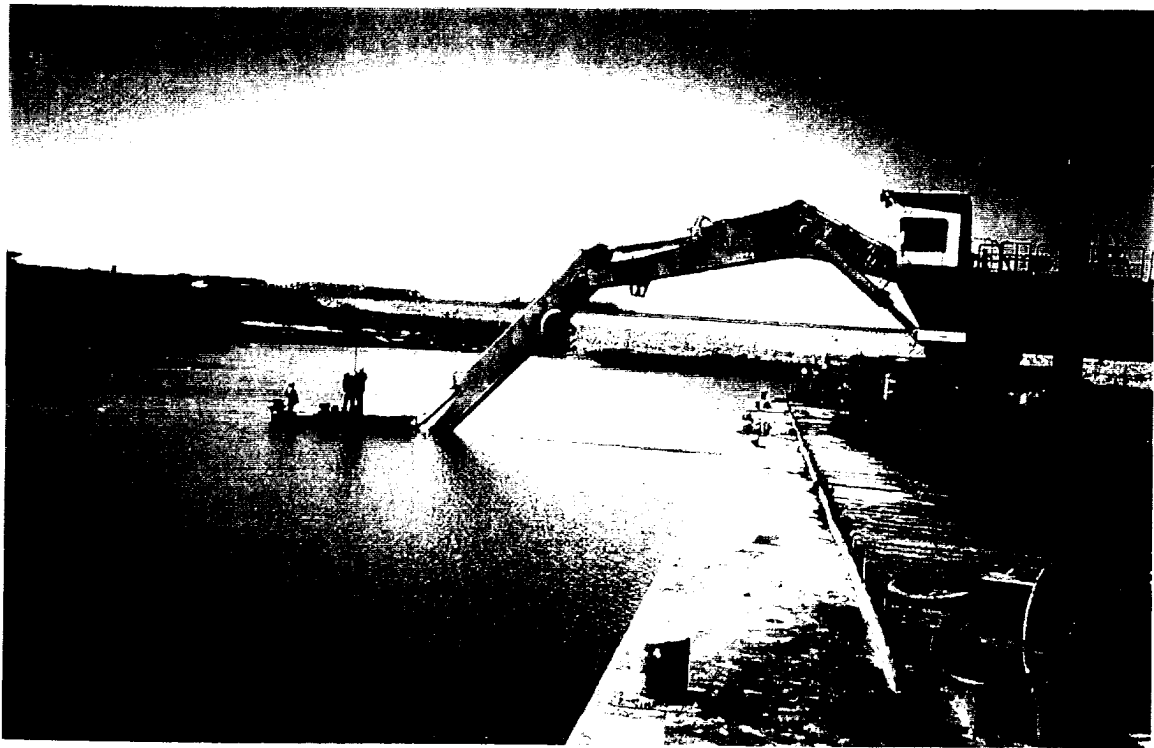

3. Exploring for Tertiary rock in the upstream channel.



**4. Government well used for pump test.
Note iron encrusted sand and gravel
encapsulating the well screen.**

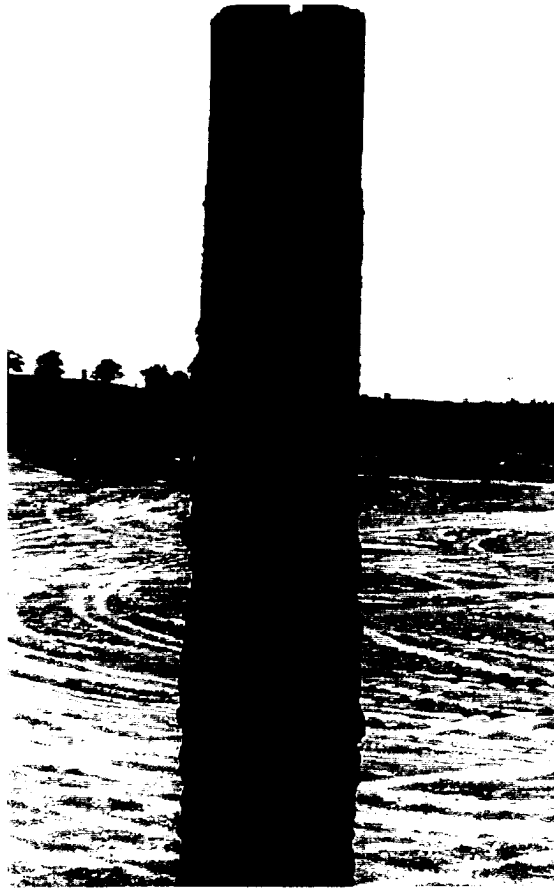

5. Government installed well used for pump test.
Note encrustation caused by ground water.



6. Fresh exposure of Tertiary claystone at the base of
the Prairie Terrace alluvium.



7. Exposure of Tertiary materials during low water in the excavation for the downstream access channel.



8. Tertiary sand containing minor rock stringers.



**9. Exposure of Tertiary sand and clay at final grade.
Note differential weathering.**

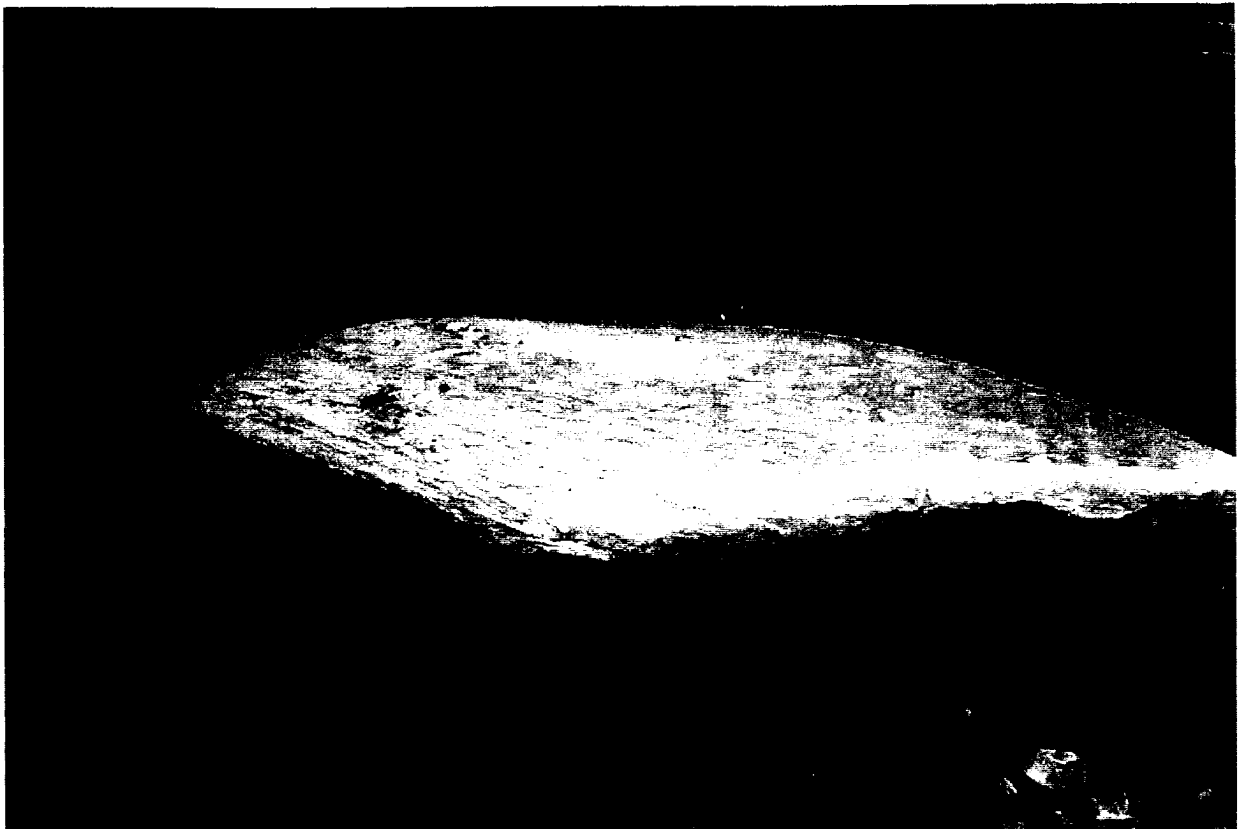

10. Lenticular sandstone "weathering out" from Tertiary sand matrix.

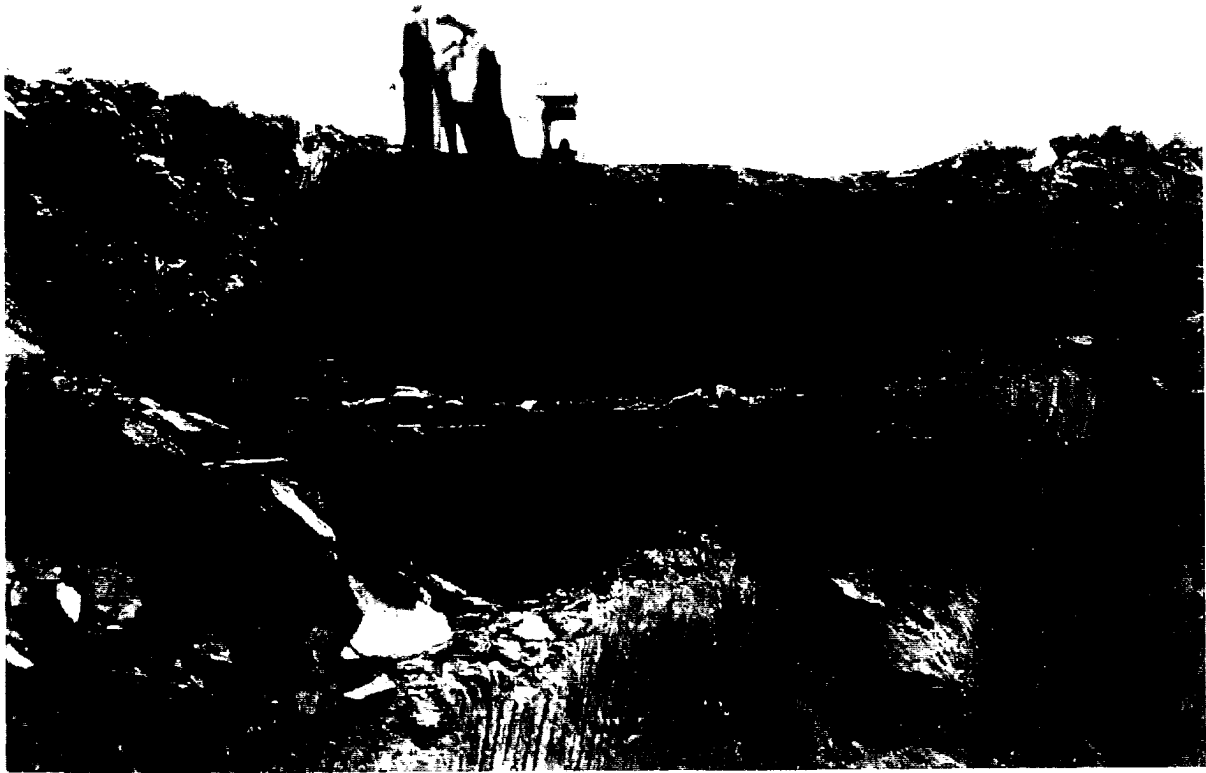

11. Laminated Tertiary claystone.

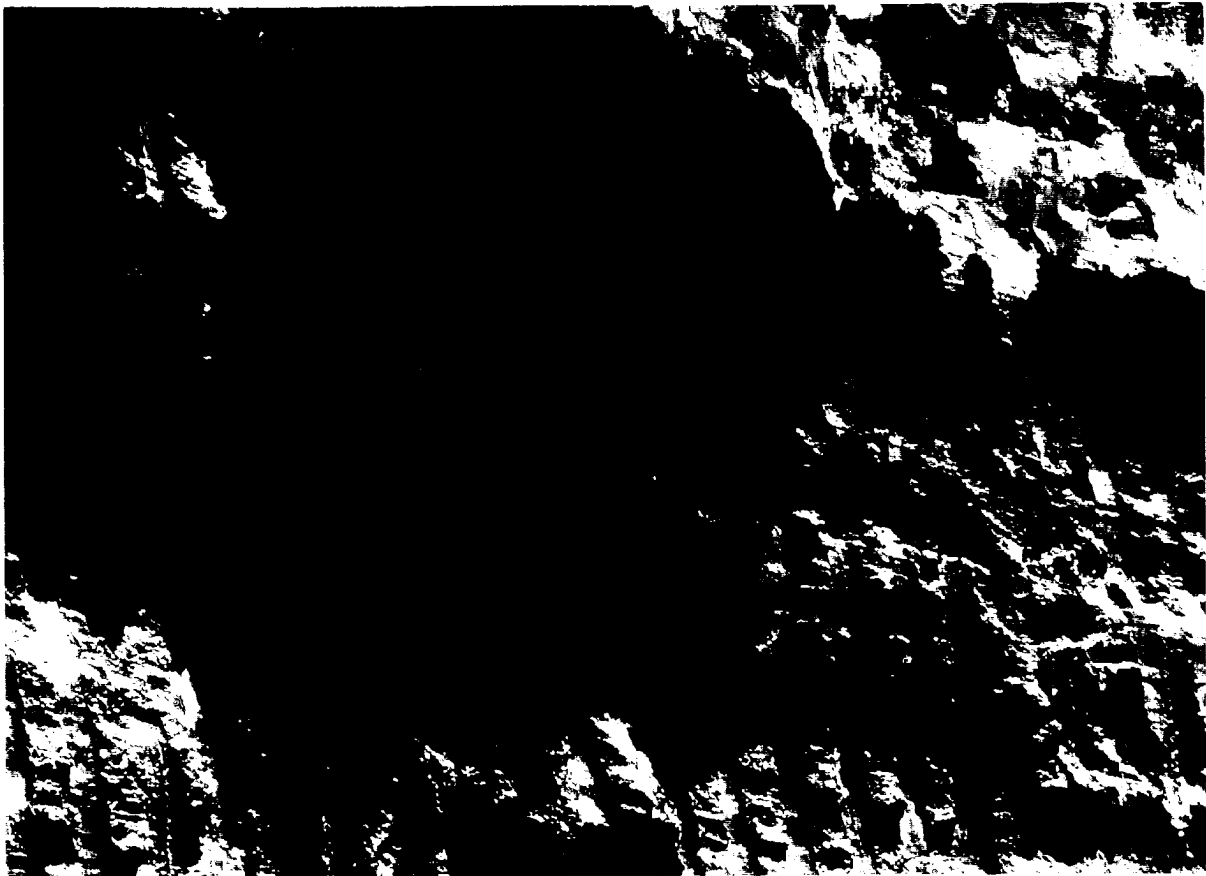

12. Freshly excavated Tertiary claystone with 2-inch rock stratum.

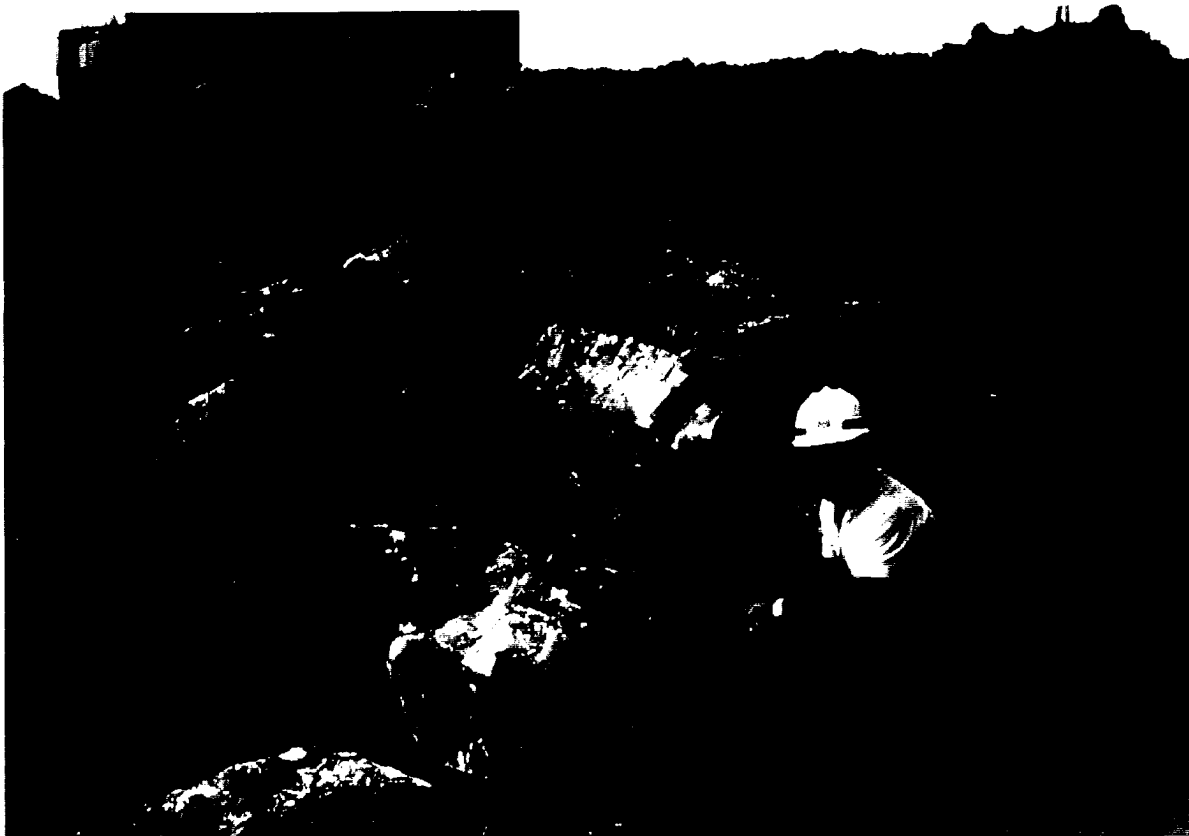

13. Tertiary rock.

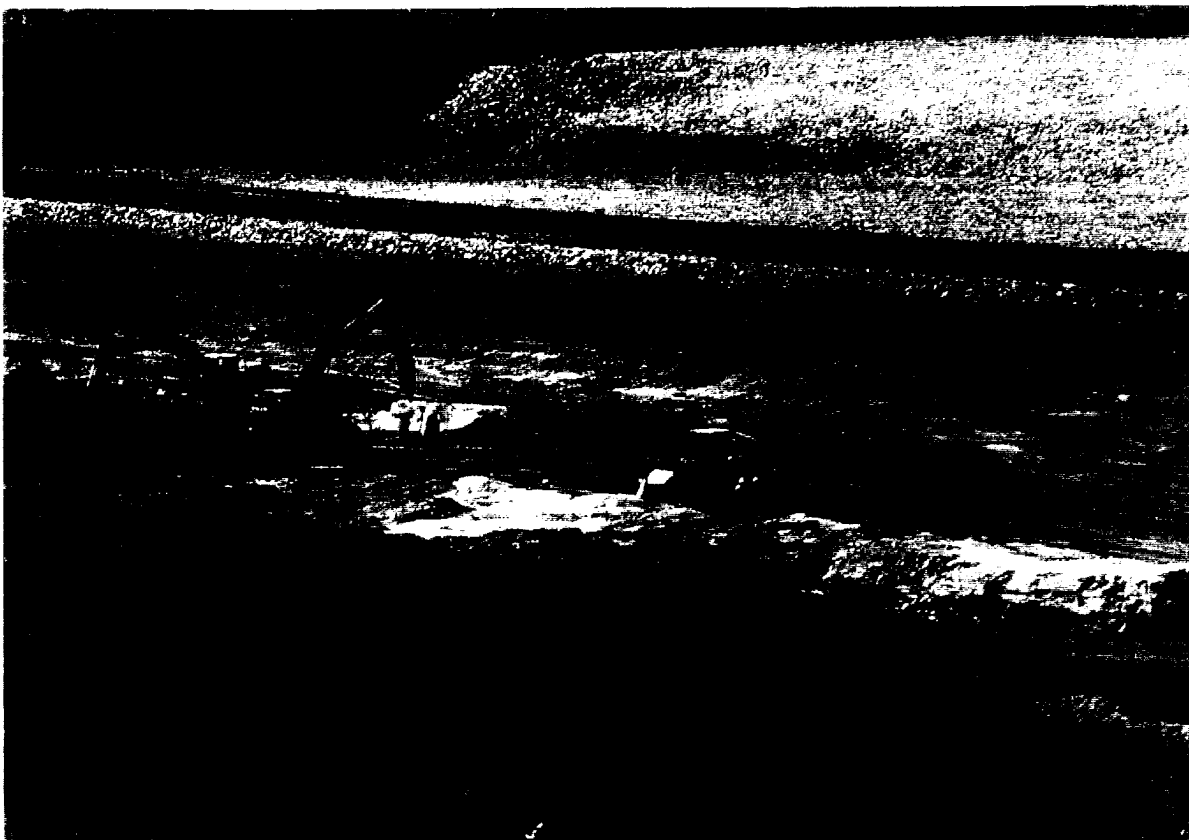

14. Excavating Tertiary rock using a hydraulic hammer.



15. Excavating Tertiary rock stratum using hydraulic hammer.



16. Tertiary rock to be transported to the spoil area.

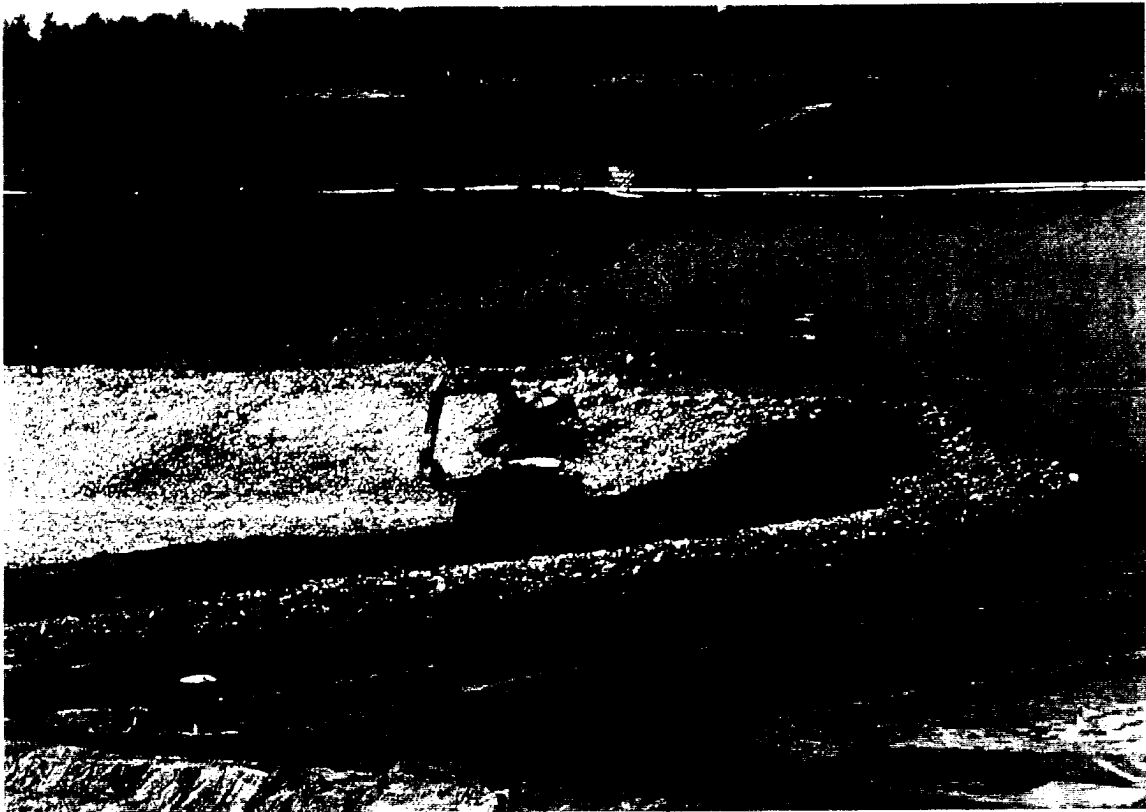

17. Placement of R205 riprap on bedding stone No. 1 Downstream channel.



16. Placement of R650 riprap on filter stone on engineering fabric
reverse side of lock monolith L - 17.



19. Engineering fabric installed in upstream channel.



20. Tertiary rock after processing for reuse as graded stone.



21. Tertiary rock after processing for reuse as riprap.



**22. General view of the site February 1993.
Crane in the foreground is located in silling basin.**

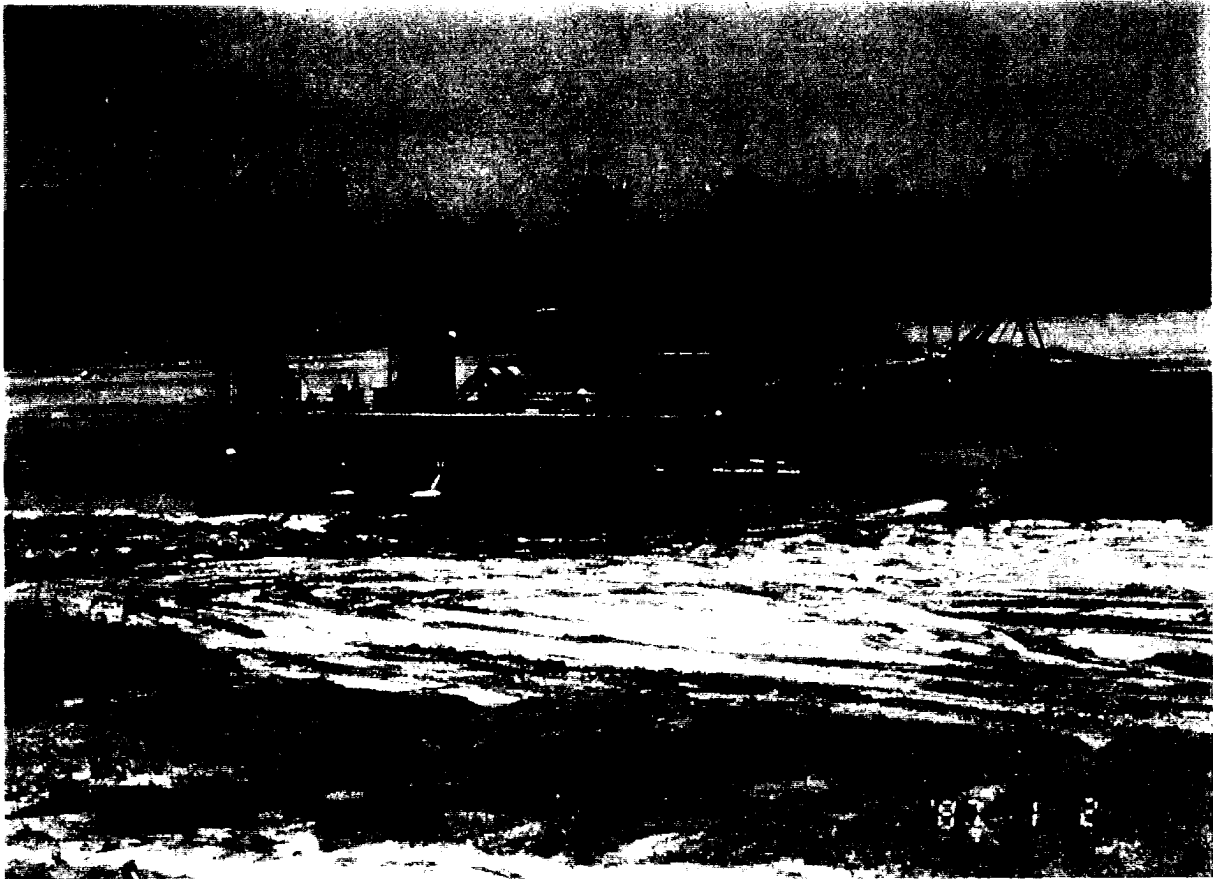

23. Cutter head dredge excavating in the downstream channel.

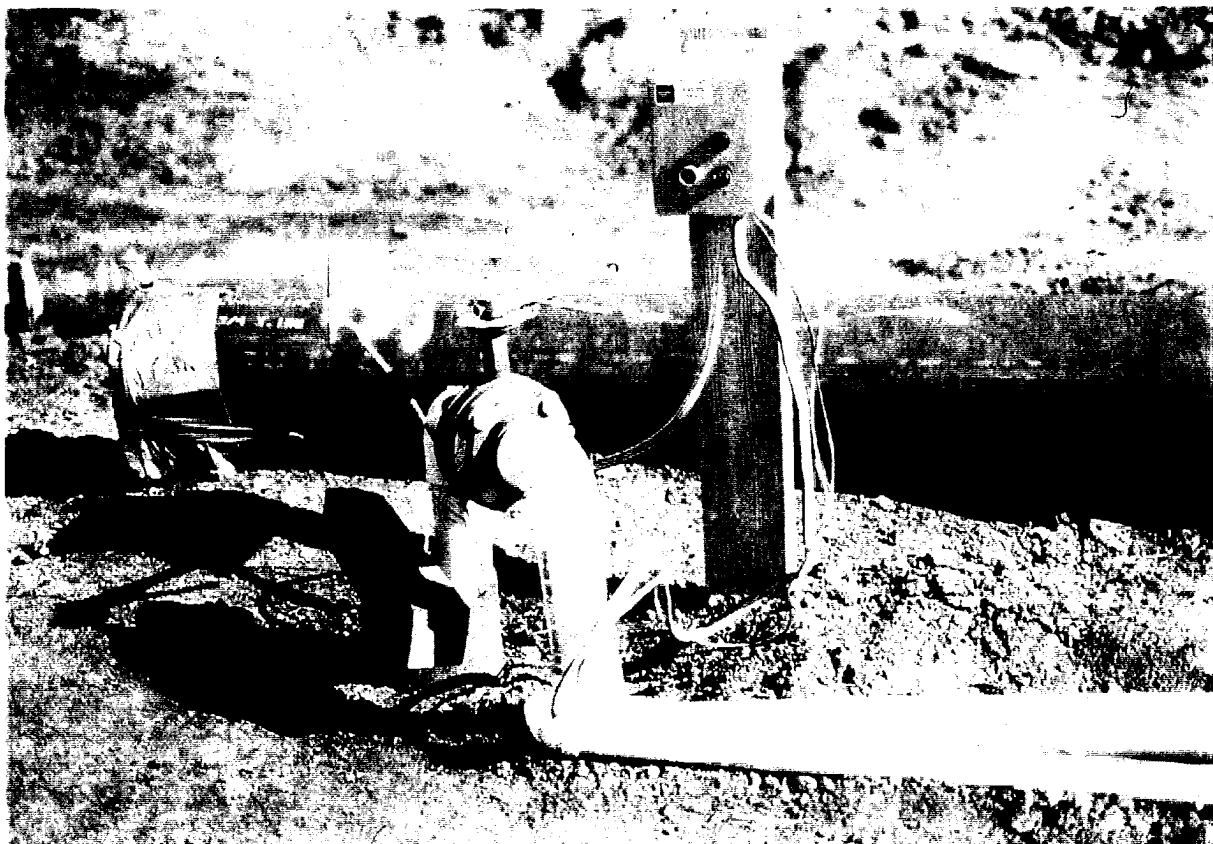

24. Typical dewatering well.



25. Wellpoint system used to lower Tertiary hydrostatic pressures for the gated dam excavation.



26. Temporary collector ditches and sump to dispose of surface water.



27. Backfilling upstream of the crest gated spillway with pervious materials. Foundation for the crest gated spillway and overflow wall has been backfilled with fully compacted select sand.

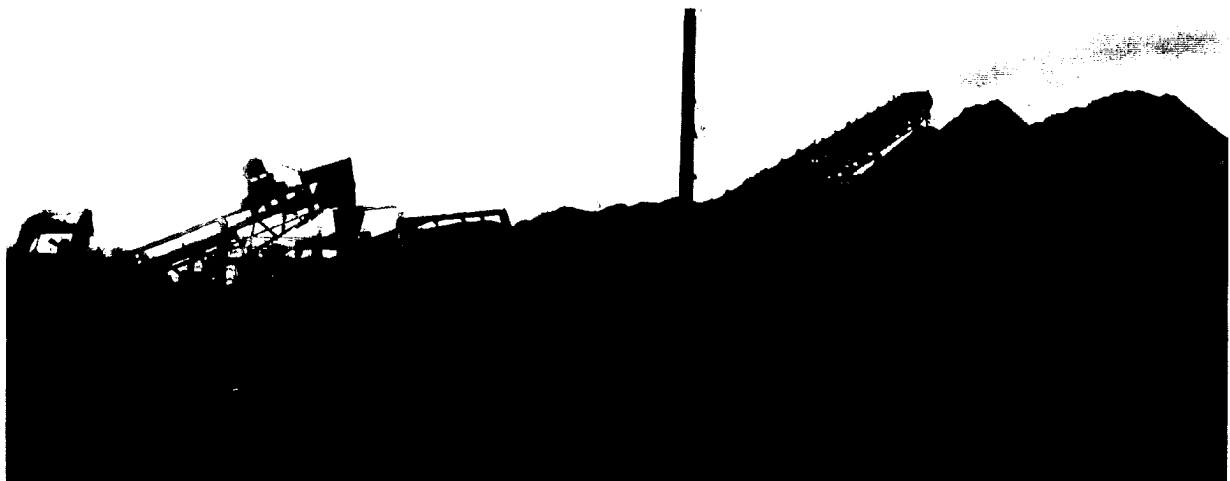

28. Processing select sand from dredged sand.

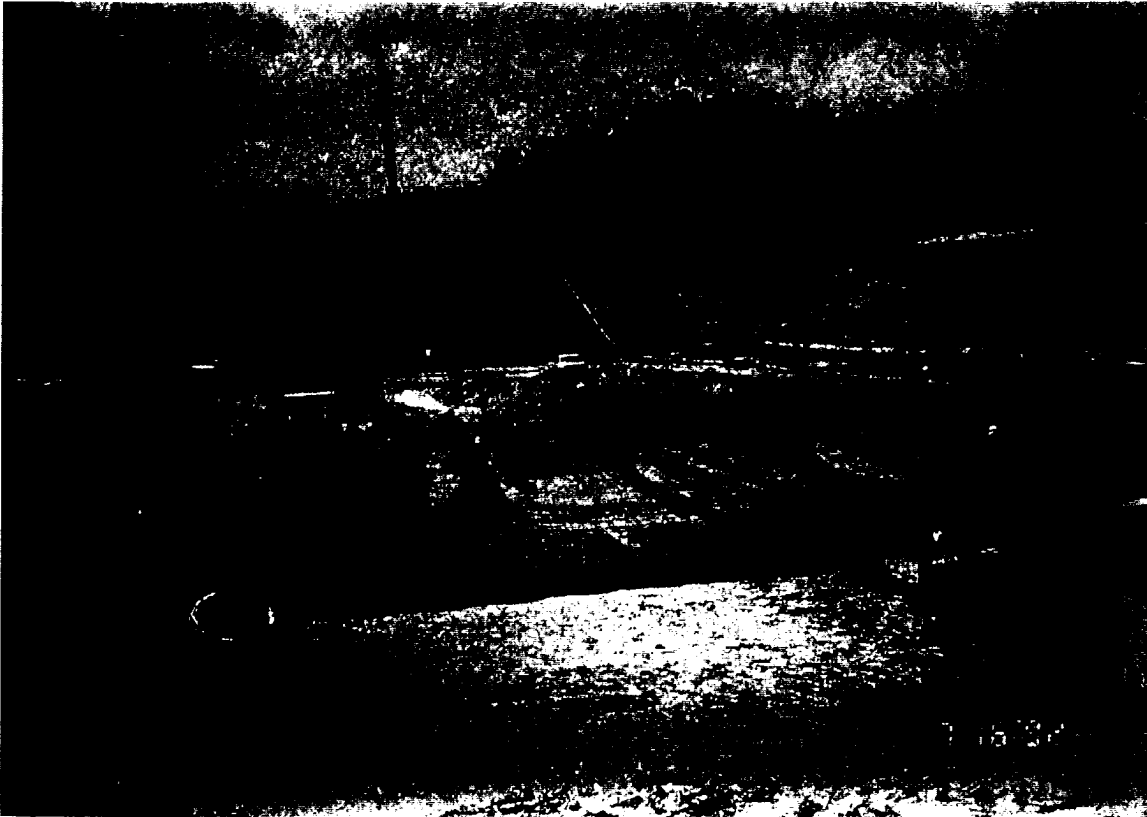

29. Spreading filter sand "B" on the foundation for the gated dam.



30. Filter gravel "C" beneath gated dam. Note stabilization slab.



31. Sheet pile installation and filter placement beneath the gated dam (right) and stilling basin (left).



32. Installation of the stainless steel collector system beneath the stilling basin. Note filter materials and sheet piling.



33. Installation of the stainless steel collector system beneath the stilling basin.

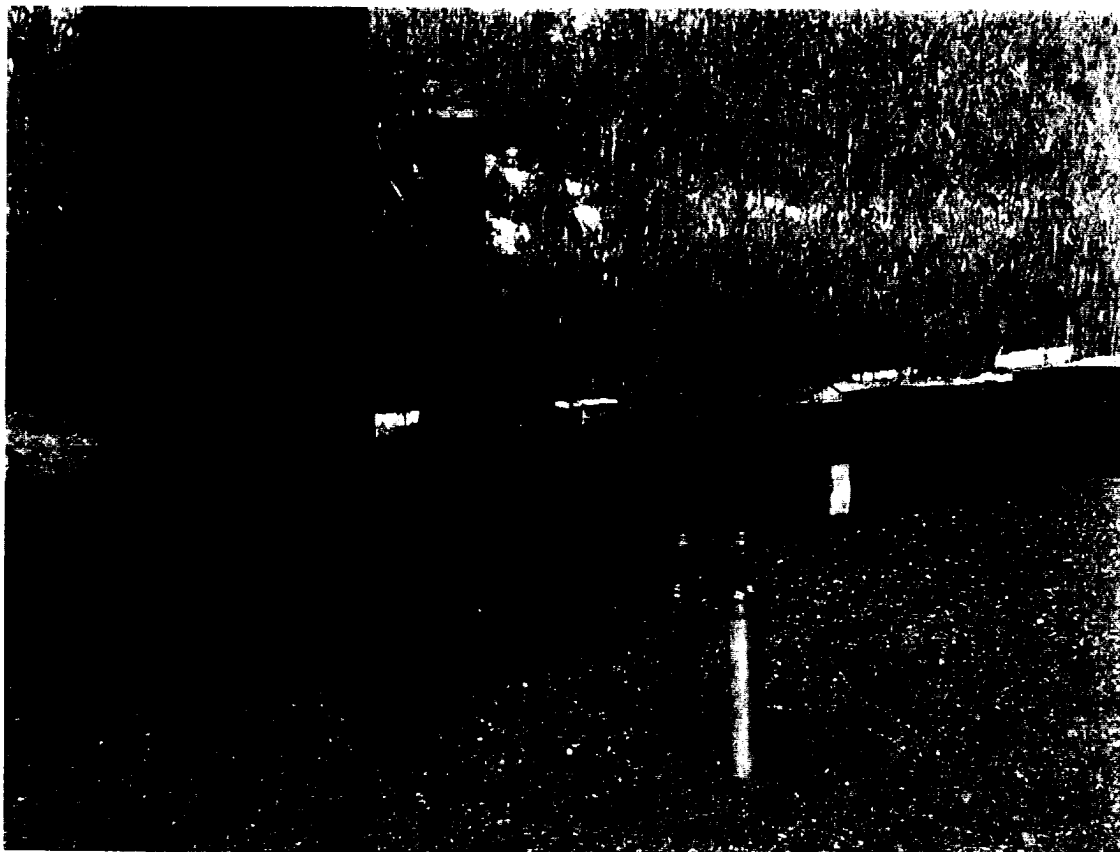

**34. Outlet pipe for under-slab drainage system beneath manifold D-4.
Note permanent piezometers P-31 and P-32 in foreground.**

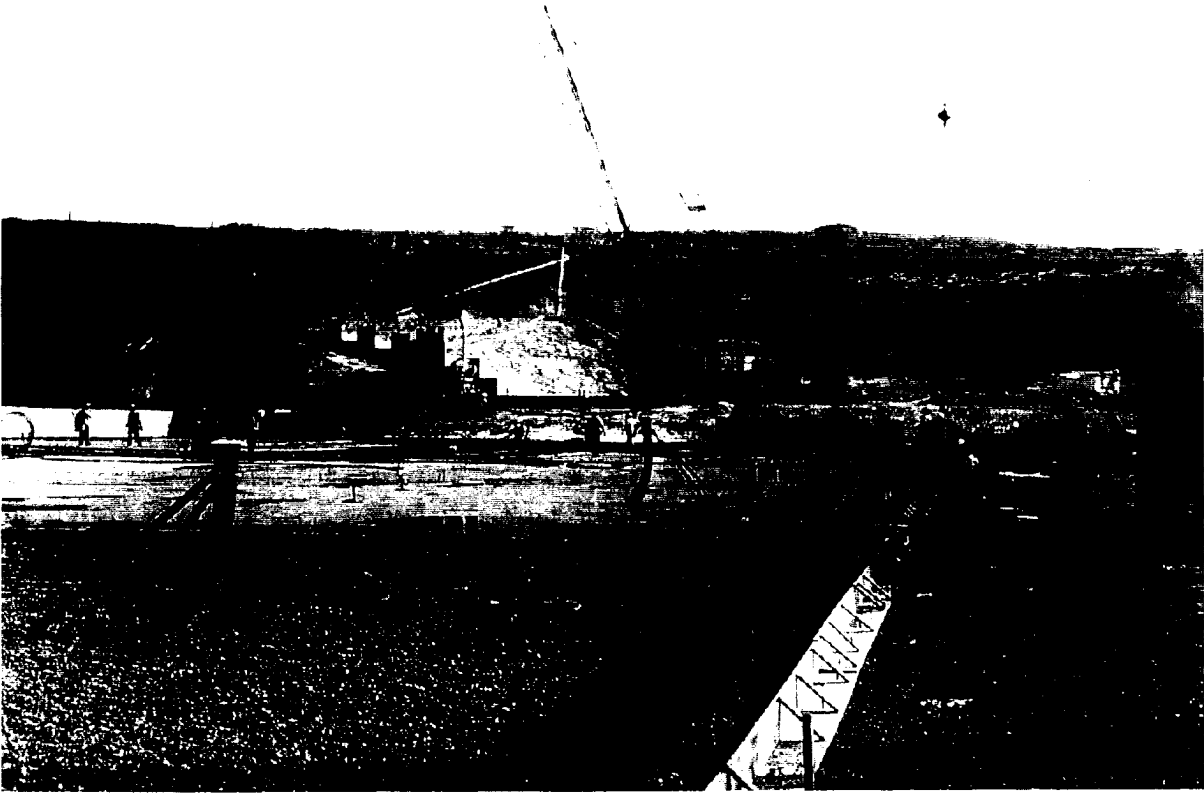

**35. Placement of stabilization slab for the gated dam.
Note discharge pipes for the under-slab drainage system and sheet piles.**



36. Installation of sheet pile in the foundation for the gated dam.

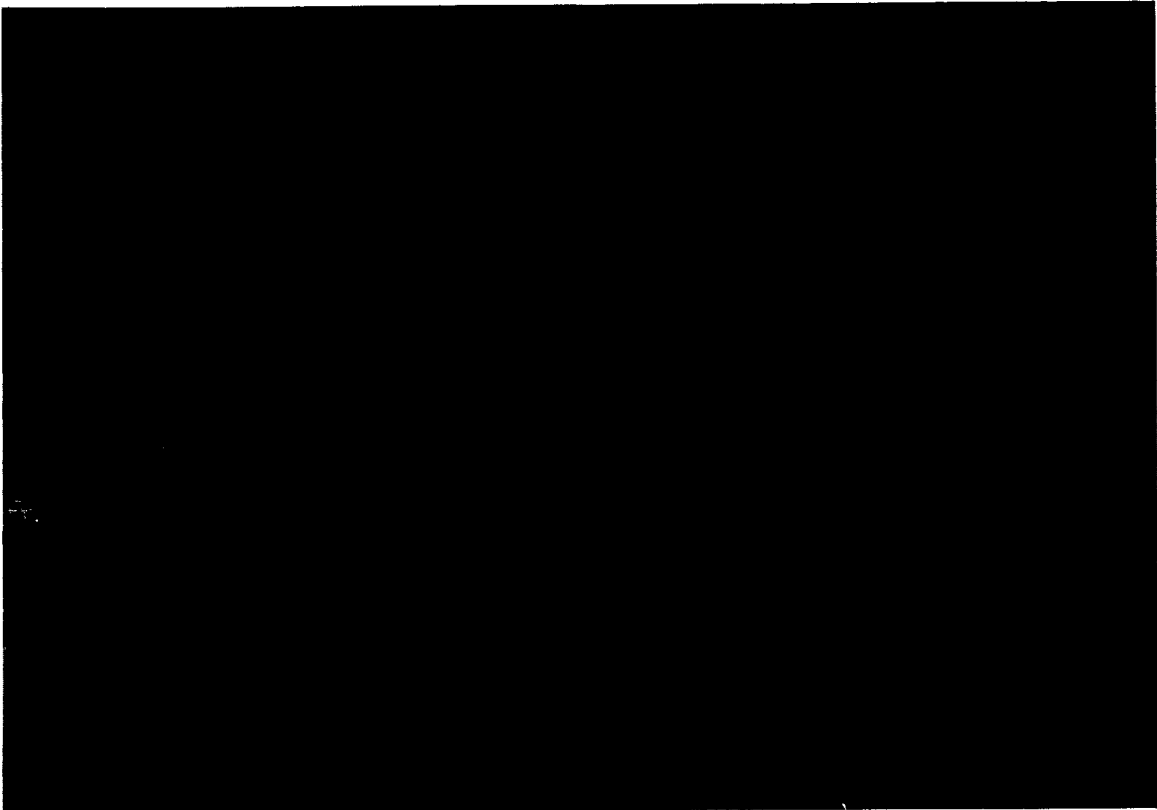

**37. Sheet pile installation beneath the gated dam and stilling basin.
Note government installed test well in foreground.**



38. Permanent piezometer beneath the stilling basin.



39. Rock stratum approximately 50 feet riverside of lock (adjacent to monoliths L-6/7 through L-17). Portions of this rock stratum were left in place in areas scheduled for random or pervious backfill.



40. Removing Tertiary rock stratum 2 feet below final grade in the upstream guardwall area to allow installation of sheet pile.



41. Tertiary rock stratum left in place downstream of lower lock gate.



42. Tension cracks preceding bank caving, upstream access channel.

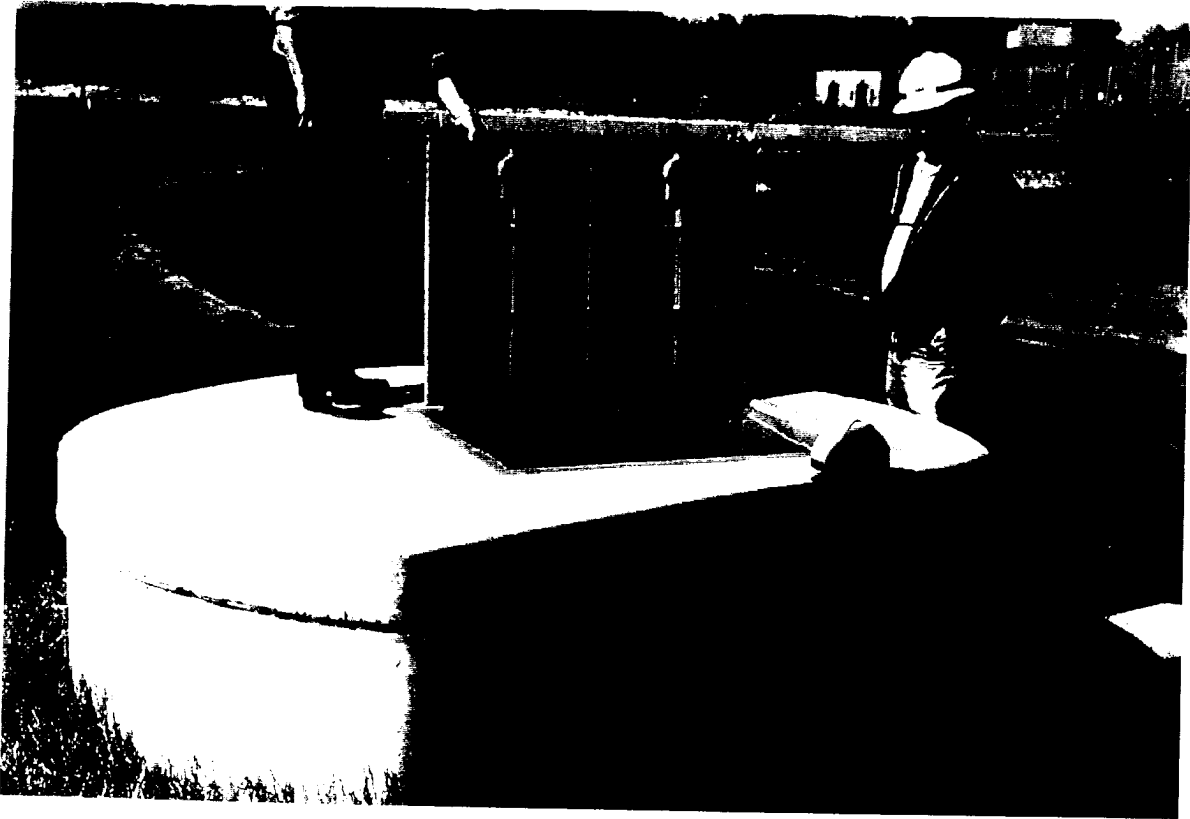

43. Backfill collector system, machine #1.



44. Interior of backfill collector system, machine #1.

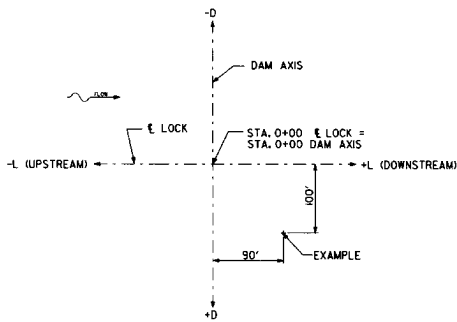
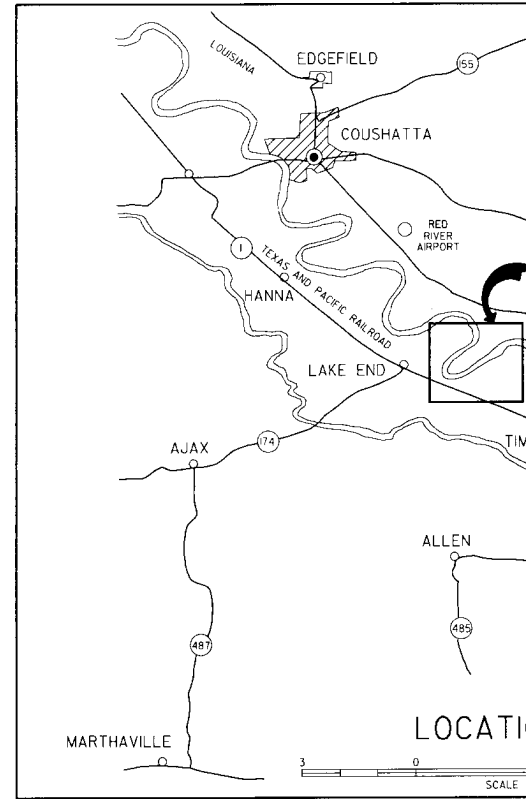
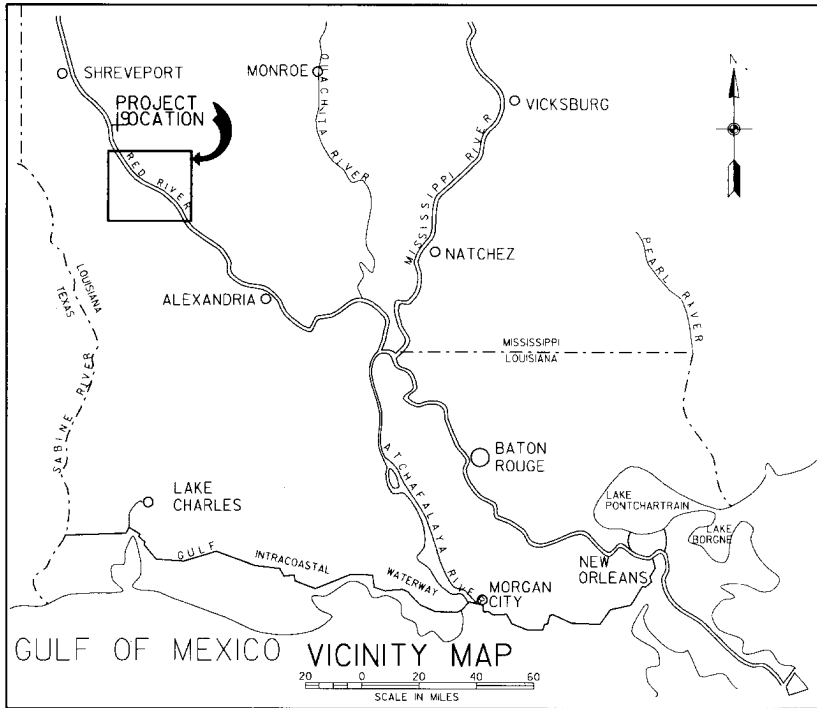

EXAMPLE
 STA. 0+90 L
 STA. 1+00 D

STATIONING KEY

NOTES:
 1. "L" BEHIND STATION DENOTES LOCK C.L. STATIONING.
 2. "D" BEHIND STATION DENOTES DAM AXIS STATIONING.

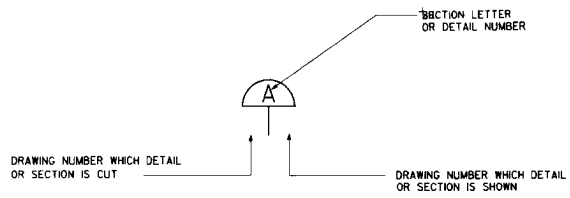

SECTION AND DETAIL IDENTIFICATION

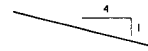

ON 4 = 1 VERT TO 4 HORIZ.

SLOPE DESIGNATION

2

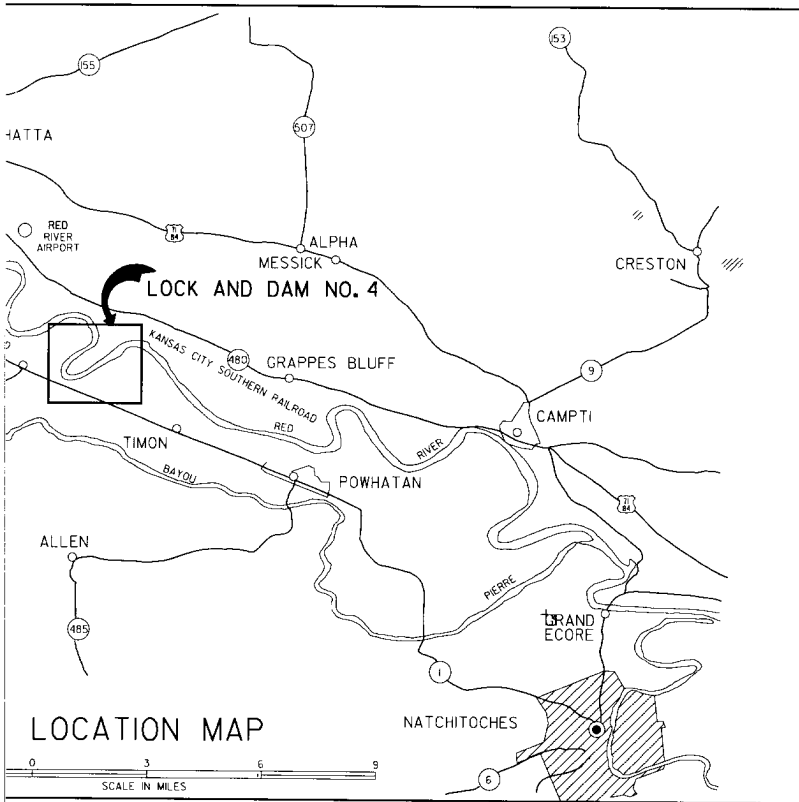

- NOTES:
1. ALL EXISTING CONTOUR MAPPING IS BASED ON AERIAL PHOTOGRAPHY TAKEN MARCH 7, 1988. EXISTING SLOPE LINES ARE BASED ON PHASE I CONSTRUCTION DRAWINGS AND DO NOT REFLECT AS BUILT CONDITIONS. TOP OF RIVER BANK CHANGES ARE INDICATED BY DATED SURVEY LINES.
 2. ALL ELEVATIONS ARE REFERENCED TO N.G.V.D. (NATIONAL GEODETIC VERTICAL DATA).
 3. THE LOCK AND DAM (E 10+00L 0+00D) IS EQUAL TO STATE PLANE COORDINATE N 463,828.03, E 1,761,007.07.

LEGEND

206	RIVER MILE (1967)
	TIMBER PILE DIKE
	PROPOSED LEVEE
	RAILROAD
	UNIMPROVED ROADS
	IMPROVED ROADS
	TREE
	WOODS
	FENCE
	DRAINAGE LINE
	OR SHORE LINE
	GASLINE
	SURVEY MONUMENT
	PIEZOMETER
	POLE LINE
	RIPRAP IN SECTION
	EXISTING GROUND SURFACE
	FINISHED EARTH FILL LINE
	SELECT CLAY BACKFILL
	RIPRAP IN PLAN
	EXISTING SLOPE LINE
	NEW SLOPE LINE
	EXISTING CONTOUR
	PROPOSED CONTOUR
	AS NOTED
	AS NOTED
	CULVERT
	R/W AS NOTED
	CONSTRUCTION R/W
	TELEPHONE LINE
	SECTION CORNER
	TOP OF BANK SURVEY LINE

RED RIVER WATERWAY-MISSISSIPPI RIVER TO SHREVEPORT, L.A.
 U. S. ARMY ENGINEER DISTRICT, VICKSBURG
 CORPS OF ENGINEERS
 VICKSBURG, MISSISSIPPI

LOCK AND DAM NO.4

FOUNDATION REPORT

PROJECT LOCATION AND VICINITY MAP

DATE: JANUARY 1996 FILE NO. R-14-206 PLATE I

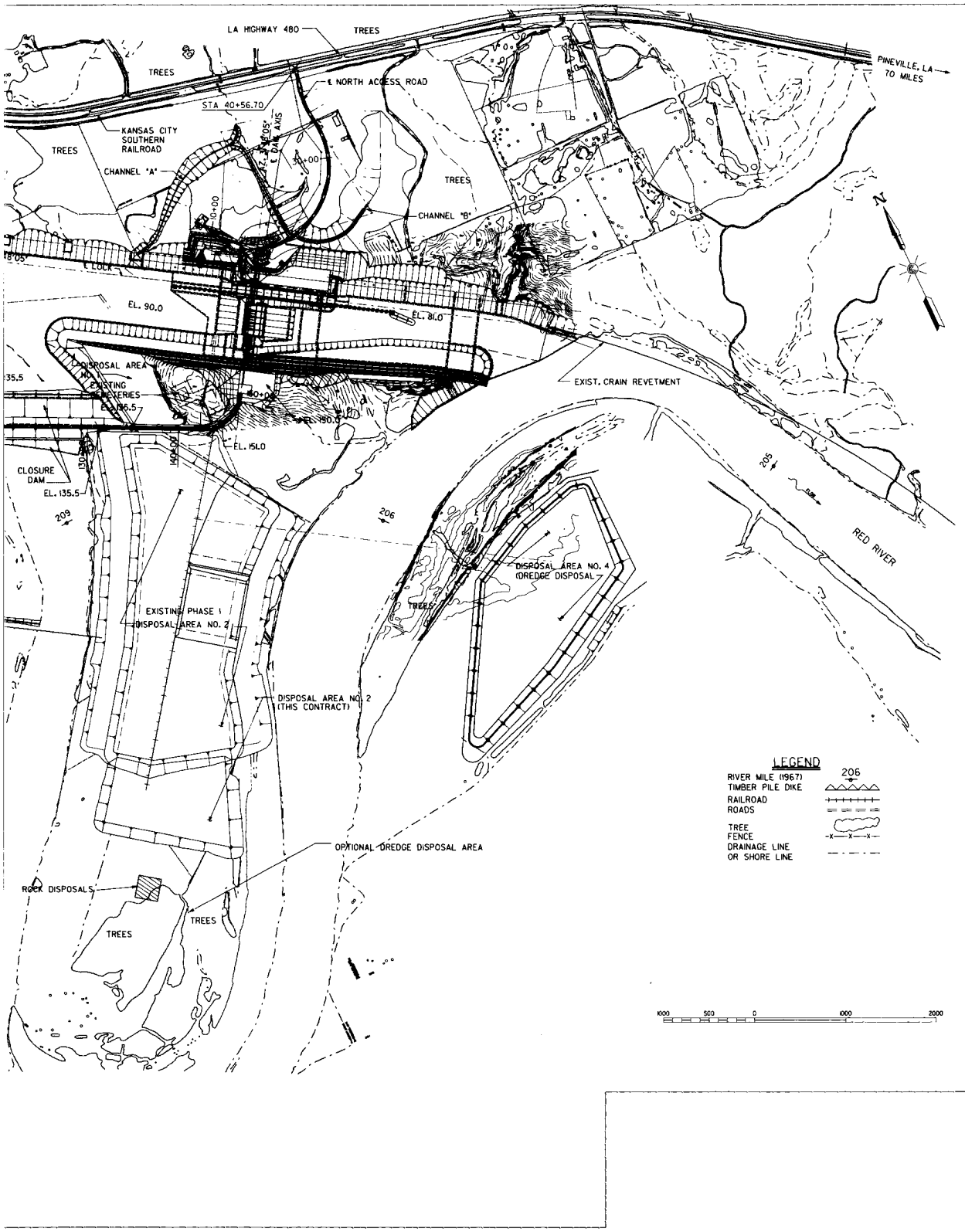

RED RIVER WATERWAY-MISSISSIPPI
 U. S. ARMY ENGINEER DISTRICT
 CORPS OF ENGINEERS
 VICKSBURG, MISSISSIPPI

LOCK AND DAM FOUNDATION

COMPLETED

DATE: JANUARY 1996 FILE NO.

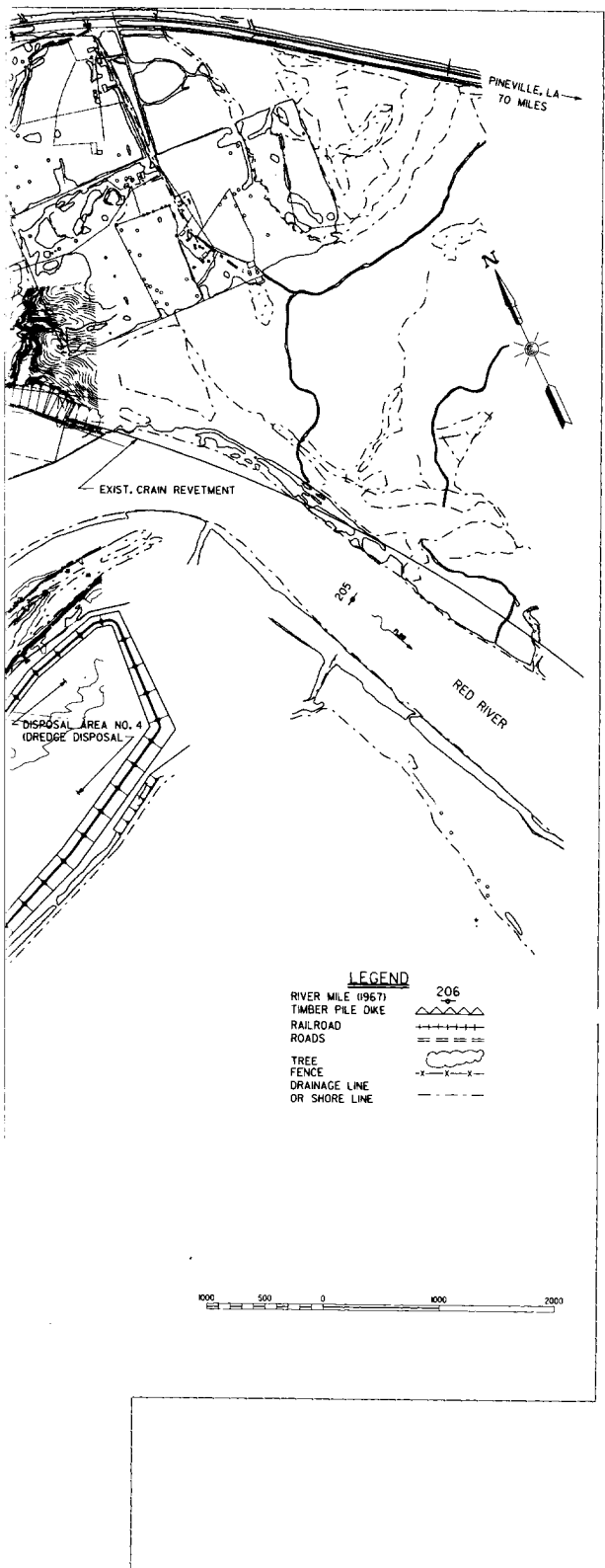

W

RED RIVER WATERWAY-MISSISSIPPI RIVER TO SHREVEPORT, LA.
 U. S. ARMY ENGINEER DISTRICT, VICKSBURG
 CORPS OF ENGINEERS
 VICKSBURG, MISSISSIPPI

LOCK AND DAM NO. 4

FOUNDATION REPORT

COMPLETED PLAN

DATE: JANUARY 1996 FILE NO. R-14-206 PLATE 2

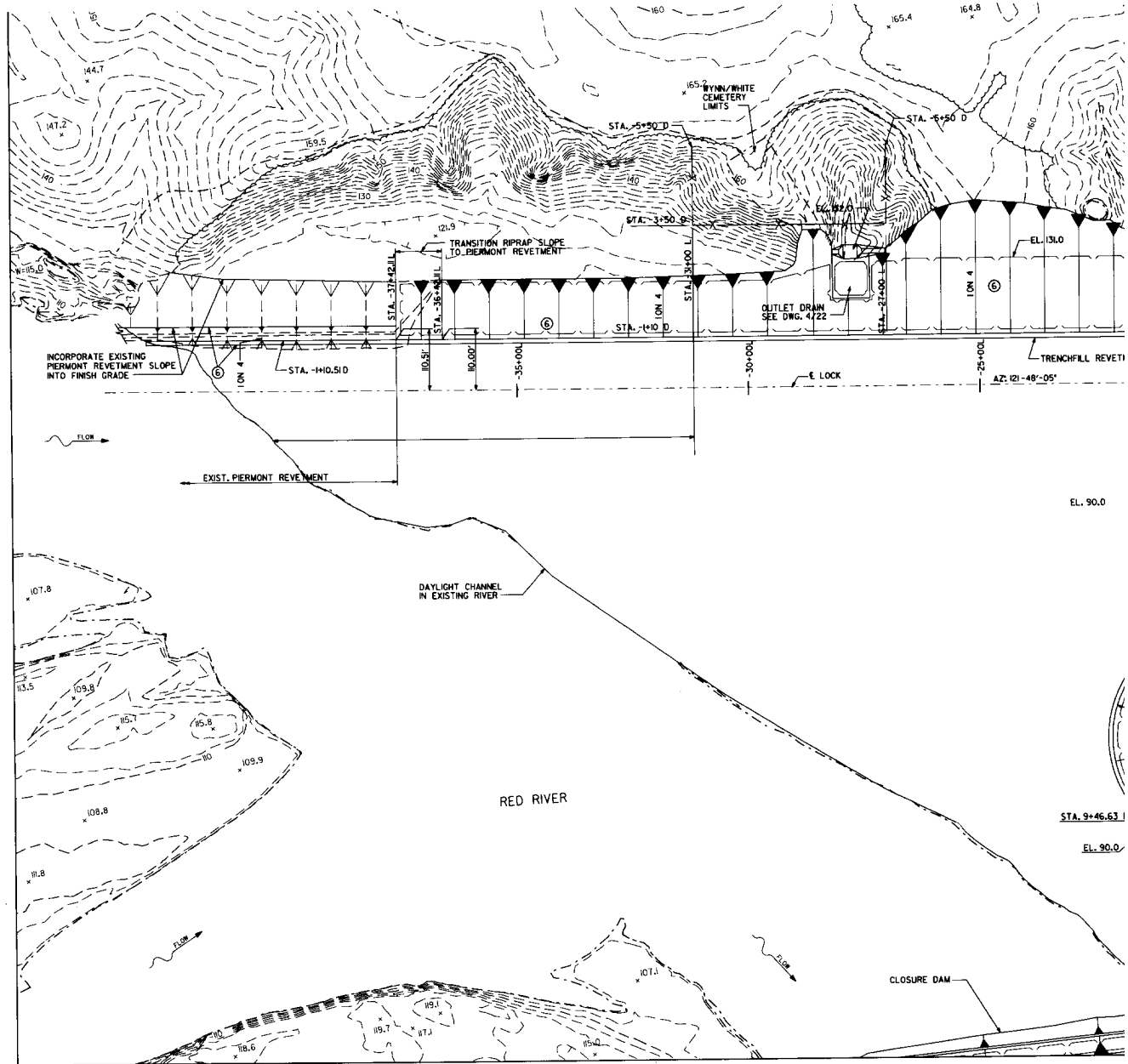

UNP/2022.05

2

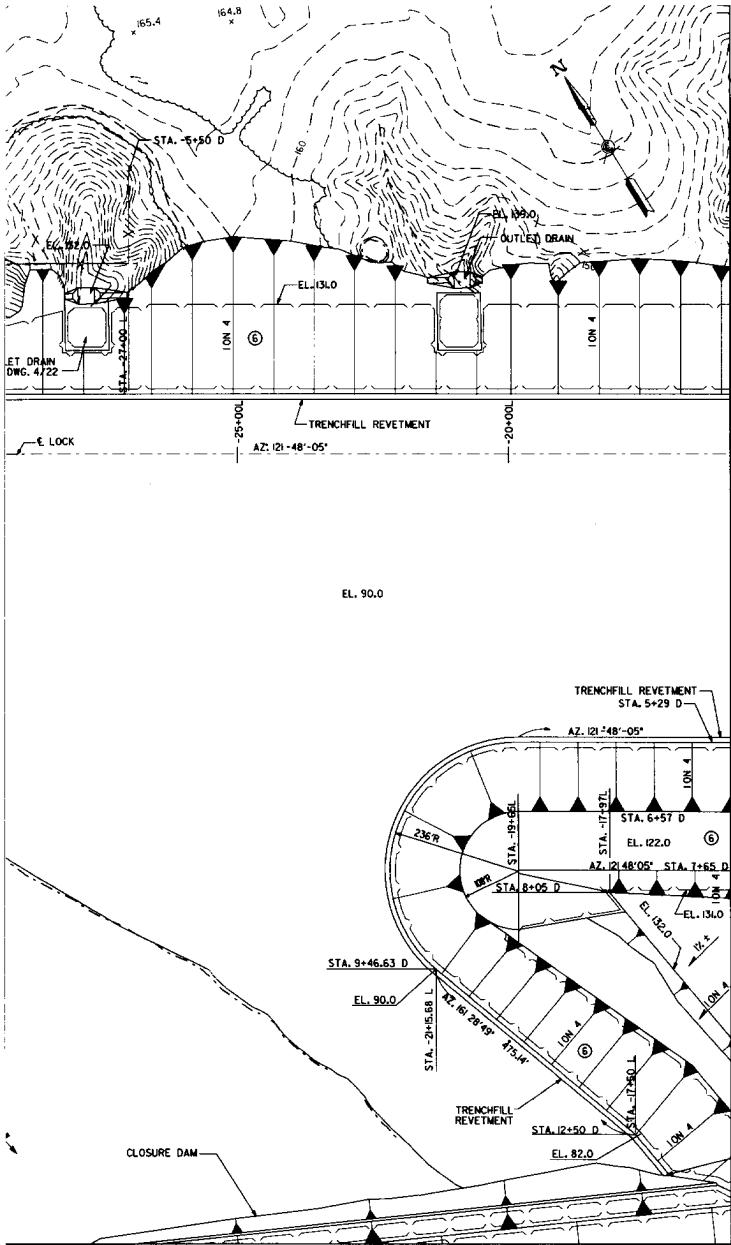

- NOTES:
1. 'L' BEHIND STATION DENOTES LOCK C.L. STATIONING.
 2. 'D' BEHIND STATION DENOTES DAM AXIS STATIONING.
 3. THICKNESS OF RIPRAP AND BEDDING PLACED SUBSEQUENTLY SHALL BE CONTROLLED BY PLACEMENT SPECIFIED IN SPECIFICATIONS.

LEGEND

- LIMITS OF RIPRAP.
- (6) 18" GRADED STONE "C".

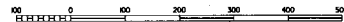

RED RIVER WATERWAY-MISSISSIPPI
 U. S. ARMY ENGINEER DISTRICT
 CORPS OF ENGINEERS
 VICKSBURG, MISSISSIPPI

**LOCK AND DAM
 FOUNDATION REPAIR
 UPSTREAM CHANNEL**



DATE: JANUARY 1996 FILE NO. R

2

MATCHLINE PLATE 4

- NOTES:
1. 1' BEHIND STATION DENOTES LOCK C.L. STATIONING.
 2. 0' BEHIND STATION DENOTES DAM AXIS STATIONING.
 3. THICKNESS OF RIPRAP AND BEDDING PLACED SUBSEQUENTLY SHALL BE CONTROLLED BY PLACEMENT SPECIFIED IN SPECIFICATIONS.

LEGEND

-  LIMITS OF RIPRAP.
-  18" GRADED STONE "C".

END TRENCHFILL
AT CLOSURE DAM
STONE DIKE

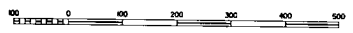

RED RIVER WATERWAY-MISSISSIPPI RIVER TO SHREVEPORT, LA.
 U. S. ARMY ENGINEER DISTRICT, VICKSBURG
 CORPS OF ENGINEERS
 VICKSBURG, MISSISSIPPI

LOCK AND DAM NO. 4
 FOUNDATION REPORT
 UPSTREAM CHANNEL PLAN

DATE: JANUARY 1996 FILE NO. R-14-206 PLATE 3

MATCHLINE PLATE 3

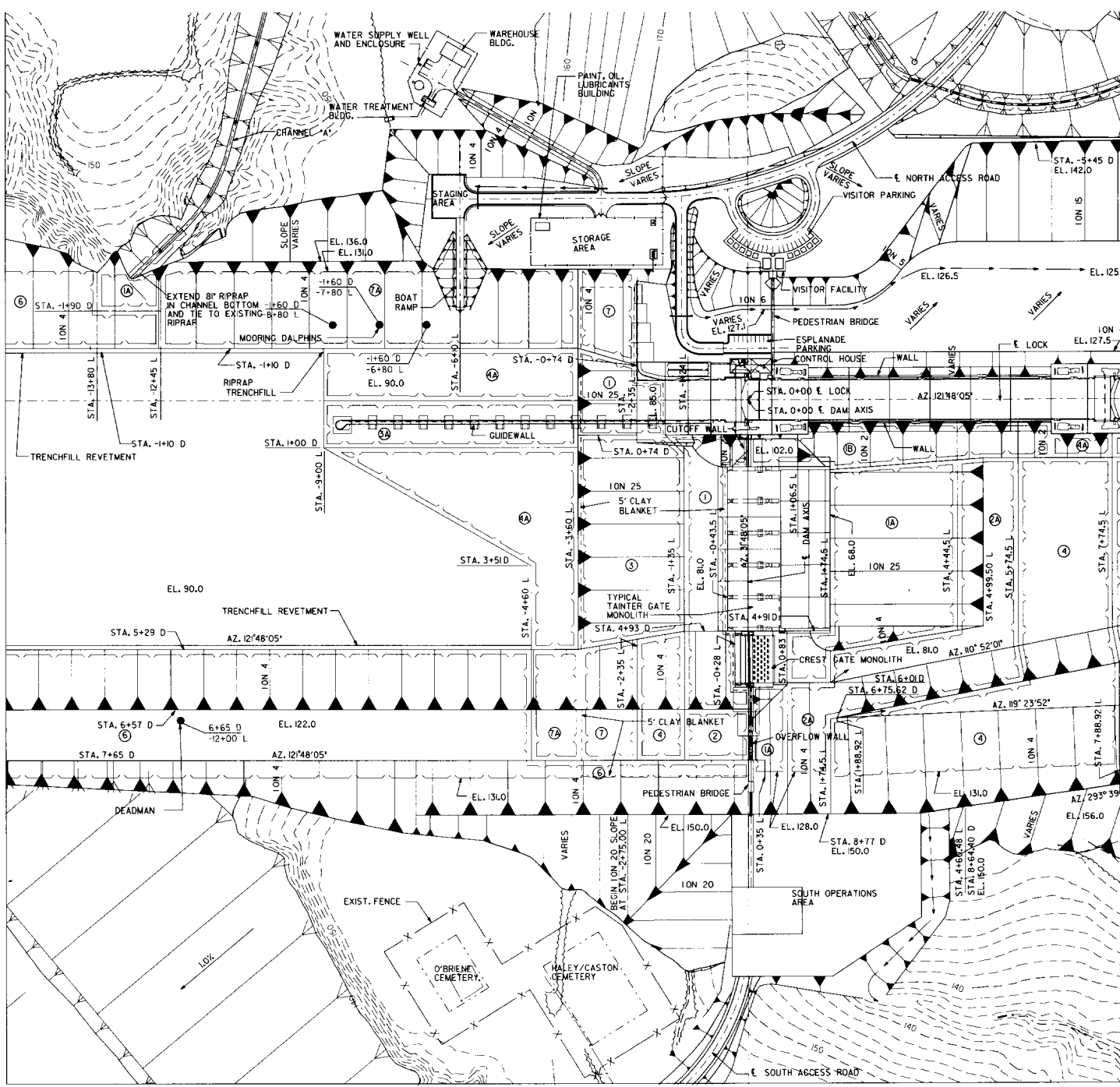

LEGEND

- ① 8" RIPRAP R7400 ON 12" RIPRAP R90 ON 6" BEDDING MATERIAL NO. 1.
- ①A 8" RIPRAP R7400 ON 12" RIPRAP R90 ON 24" FILTER MATERIAL.
- ①B 8" RIPRAP R7400 ON 12" RIPRAP R90 ON ENGINEERING FABRIC ON 24" FILTER MATERIAL.
- ② 54" RIPRAP R2200 ON 12" RIPRAP R90 ON 6" BEDDING MATERIAL NO. 1.
- ②A 54" RIPRAP R2200 ON 12" RIPRAP R90 ON 24" FILTER MATERIAL.
- ③ 48" RIPRAP R1500 ON 12" RIPRAP R90 ON 6" BEDDING MATERIAL NO. 1.
- ③A 48" RIPRAP R1500 ON 12" RIPRAP R90 ON ENGINEERING FABRIC.
- ④ 36" RIPRAP R650 ON 12" BEDDING MATERIAL NO. 2.
- ④A 36" RIPRAP R650 ON 12" FILTER STONE ON ENGINEERING FABRIC.
- ⑤ 30" RIPRAP R400 ON 12" BEDDING MATERIAL NO. 2.
- ⑤A 30" RIPRAP R400 ON ENGINEERING FABRIC.
- ⑥ 18" GRADED STONE "C".
- ⑦ 16" RIPRAP R200 ON 6" BEDDING MATERIAL NO. 1.
- ⑦A 16" RIPRAP R200 ON ENGINEERING FABRIC.

PLAN

- NOTES:**
- 1. 24" FIL
 - A 6" B
 - A 6" M
 - AND A
 - 2. "A" DES
 - ON PE
 - 3. THICKN
 - SUBAD
 - PLACE

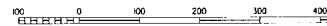

2

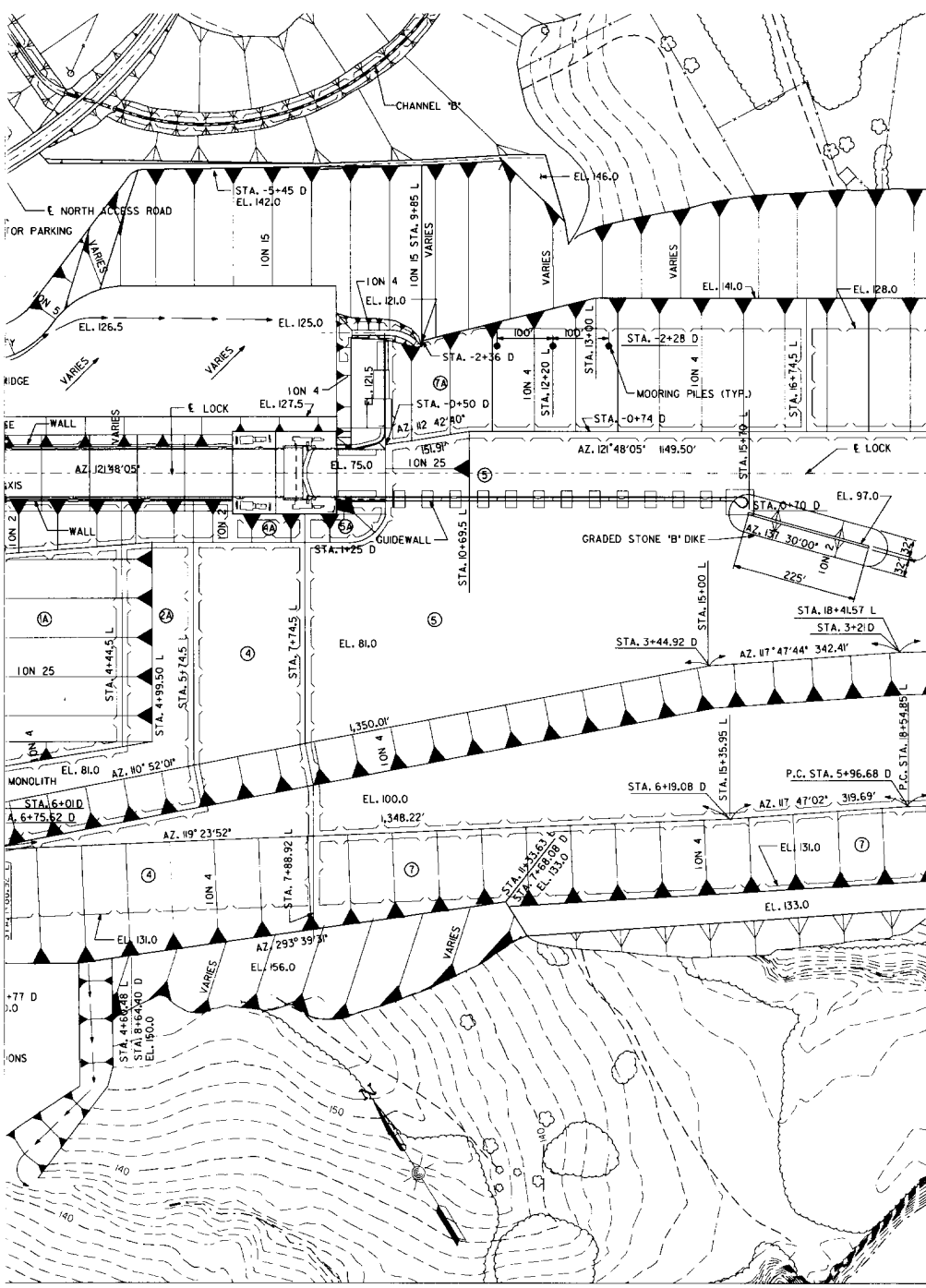

PLAN

- NOTES:
1. 24" FILTER MATERIAL CONSISTS OF:
 A. 6" BOTTOM LAYER OF SAND "S",
 B. 6" MIDDLE LAYER OF GRAVEL "C",
 AND A 12" TOP LAYER OF FILTER STONE.
 2. "A" DESIGNATION IS FOR RIPRAP PLACEMENT ON PERVIOUS MATERIAL.
 3. THICKNESS OF RIPRAP AND BEDDING PLACED SUBSEQUENTLY SHALL BE CONTROLLED BY PLACEMENT SPECIFIED IN SPECIFICATIONS.

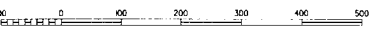

RED RIVER WATERWAY-MISSISSIPPI RIVER TO SHREVEPORT
 U. S. ARMY ENGINEER DISTRICT, VICKSBURG
 CORPS OF ENGINEERS
 VICKSBURG, MISSISSIPPI

LOCK AND DAM NO. 5
FOUNDATION REPORT
LOCK AND DAM PLATE 5

DATE: JANUARY 1996 FILE NO. R-14-206

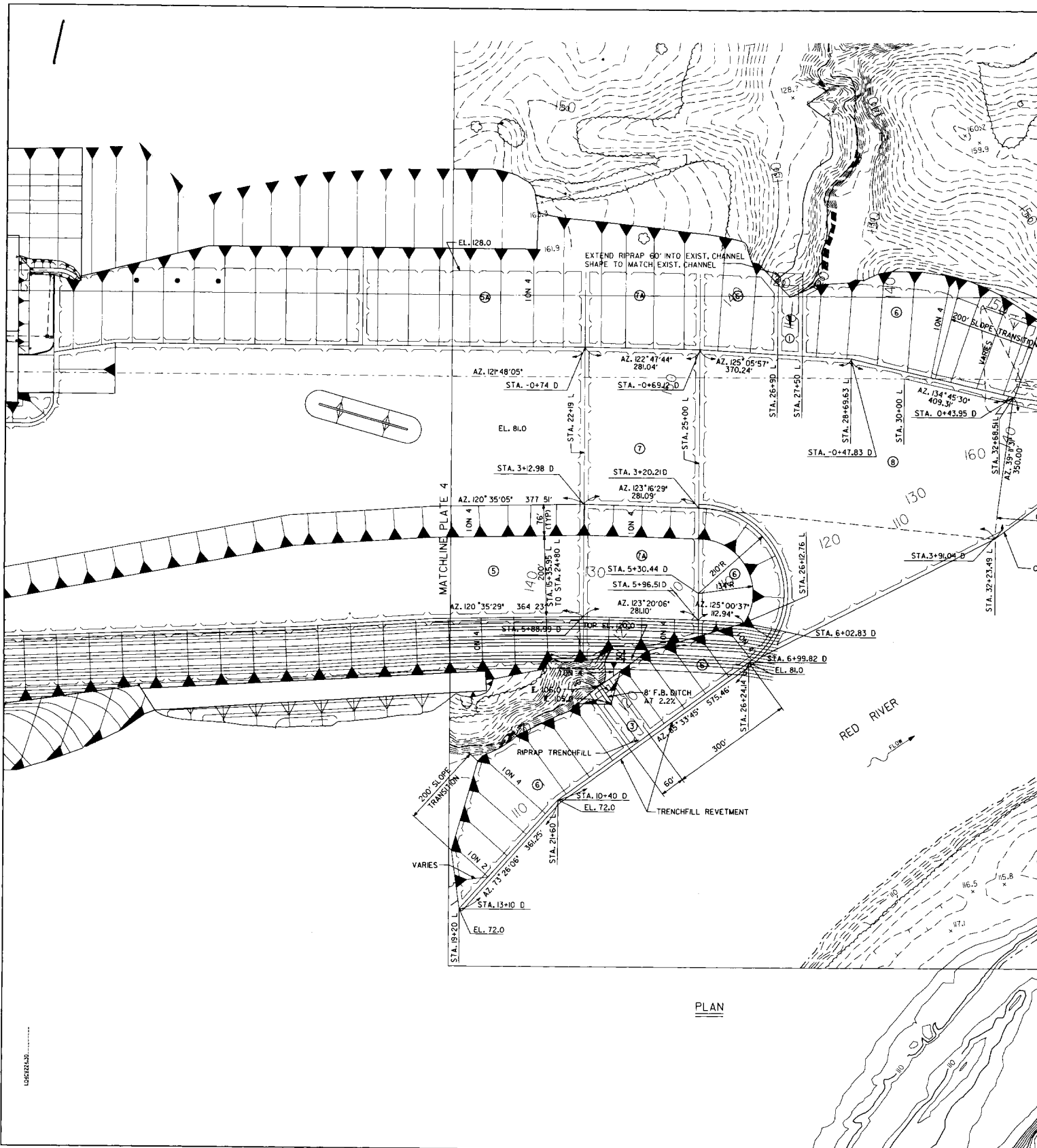

PLAN

10/20/2010

2

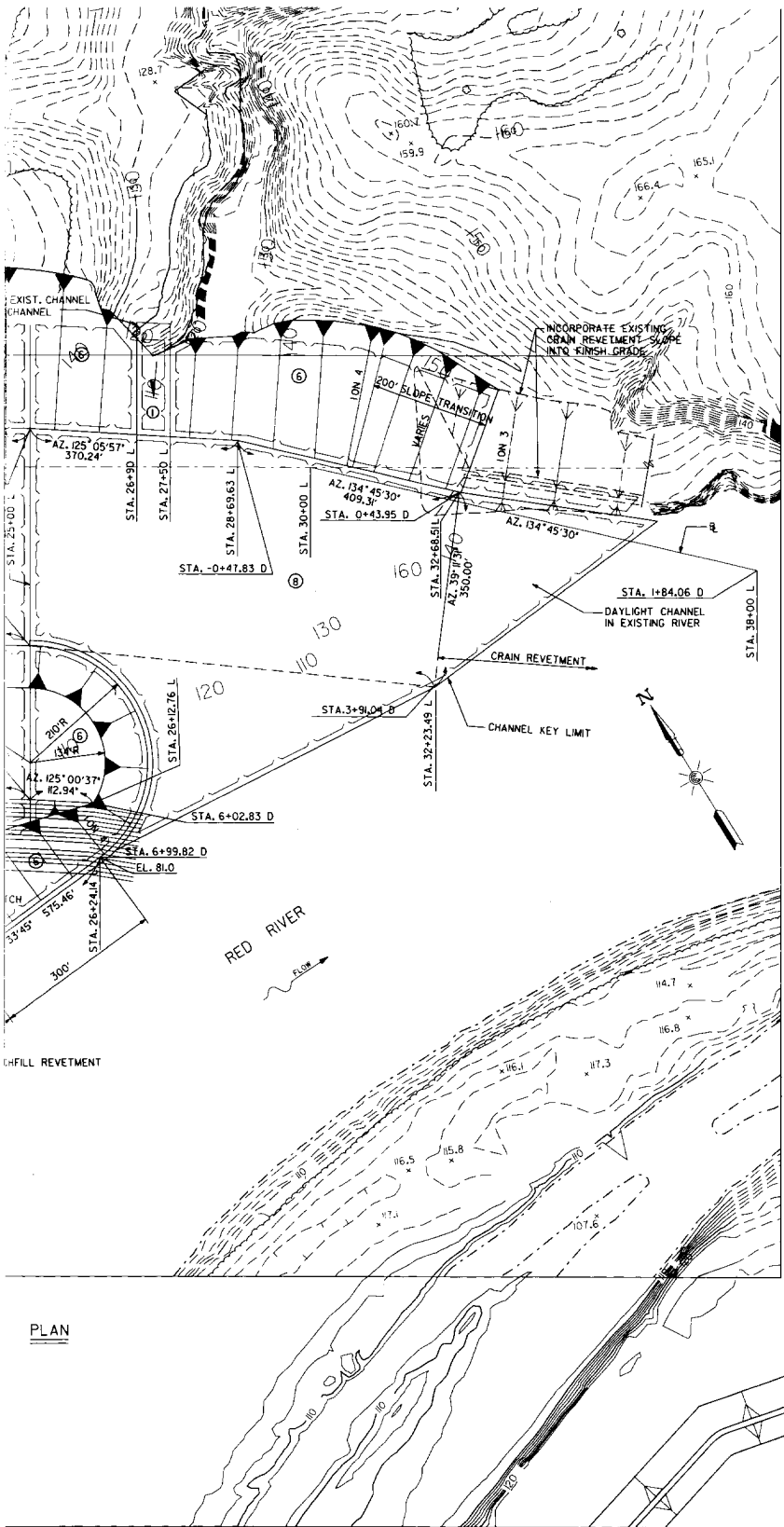

NOTE:
 1. THICKNESS OF RIPRAP AND BEDDING PLACED SUBSEQUOUSLY SHALL BE CONTROLLED BY PLACEMENT SPECIFIED IN SPECIFICATIONS.

LEGEND

- INDICATES LIMITS OF RIPRAP
- ① 8" RIPRAP R7400 ON 12" RIPRAP R90 ON 6" BEDDING MATERIAL NO. 1.
- ② 48" RIPRAP R1500 ON 12" RIPRAP R90 ON 6" BEDDING MATERIAL NO. 1.
- ③ 30" RIPRAP R400 ON 12" BEDDING MATERIAL NO. 2.
- ④ 30" RIPRAP R400 ON ENGINEERING FABRIC.
- ⑤ 18" GRADED STONE 'C'.
- ⑥ 16" RIPRAP R200 ON 6" BEDDING MATERIAL NO. 1.
- ⑦ 16" RIPRAP R200 ON ENGINEERING FABRIC.
- ⑧ 12" RIPRAP R90 ON 6" BEDDING MATERIAL NO. 1.

RED RIVER WATERWAY-M
 U. S. ARMY ENGN
 CORPS C
 VICKSBUR

LOCK AND FOUNDAT DOWNSTRE PL

DATE: JANUARY 1996

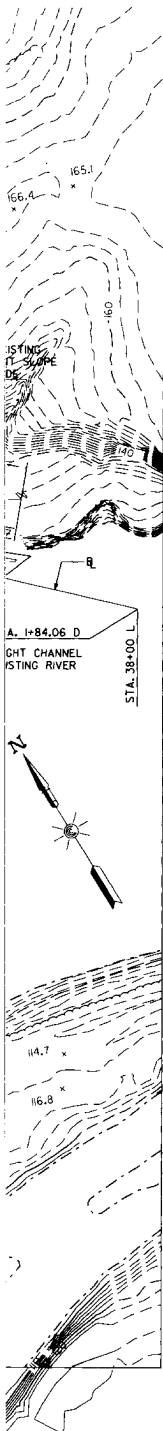

NOTE:
 1. THICKNESS OF RIPRAP AND BEDDING PLACED SUBSEQUENTLY SHALL BE CONTROLLED BY PLACEMENT SPECIFIED IN SPECIFICATIONS.

LEGEND

- INDICATES LIMITS OF RIPRAP
- ① 8" RIPRAP R7400 ON 12" RIPRAP R90 ON 6" BEDDING MATERIAL NO. 1.
- ② 48" RIPRAP R1500 ON 12" RIPRAP R90 ON 6" BEDDING MATERIAL NO. 1.
- ③ 30" RIPRAP R400 ON 12" BEDDING MATERIAL NO. 2.
- ④ 30" RIPRAP R400 ON ENGINEERING FABRIC.
- ⑤ 18" GRADED STONE "C".
- ⑥ 16" RIPRAP R200 ON 6" BEDDING MATERIAL NO. 1.
- ⑦ 16" RIPRAP R200 ON ENGINEERING FABRIC.
- ⑧ 12" RIPRAP R90 ON 6" BEDDING MATERIAL NO. 1.

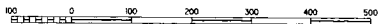

RED RIVER WATERWAY-MISSISSIPPI RIVER TO SHREVEPORT, LA.
 U. S. ARMY ENGINEER DISTRICT, VICKSBURG
 CORPS OF ENGINEERS
 VICKSBURG, MISSISSIPPI

LOCK AND DAM NO. 4
 FOUNDATION REPORT
 DOWNSTREAM CHANNEL
 PLAN

DATE: JANUARY 1996

FILE NO. R-14-206

PLATE 5

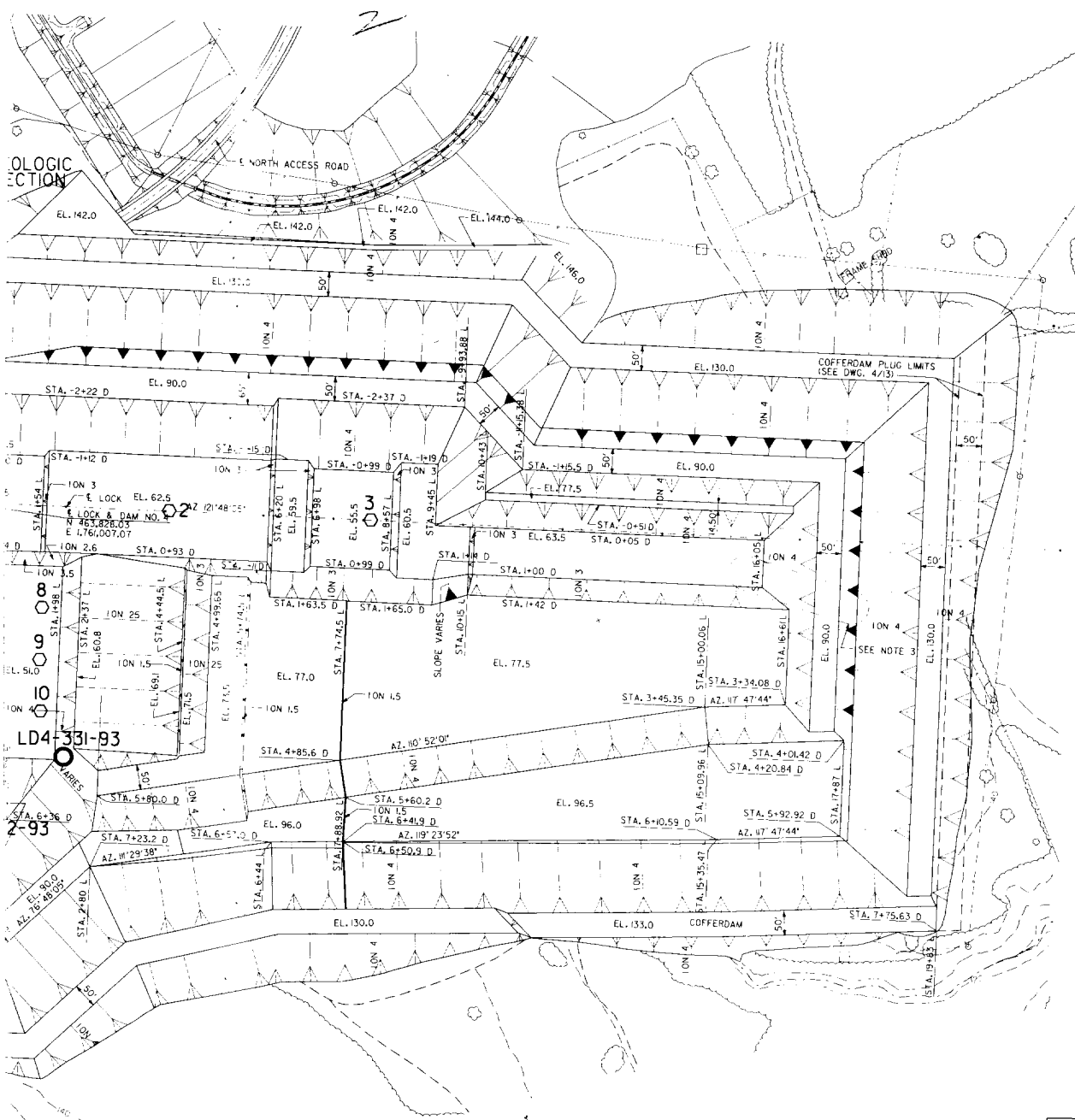

LOGIC SECTION

- NOTES:
1. FOR GEOLOGIC SECTION SEE PLATE 17 AND 18
 2. FOR FOUNDATION SAMPLE CLASSIFICATION SEE TABLE 6-1
 3. ○ = LOCATION OF FOUNDATION SAMPLES
 4. ● = GEOLOGICAL BORINGS
FOR BORING PROFILES SEE PLATE 17

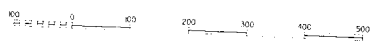

RED RIVER WATERWAY, MISSISSIPPI RIVER
 U. S. ARMY ENGINEER DISTRICT, V
 CORPS OF ENGINEERS
 VICKSBURG, MISSISSIPPI

LOCK AND DAM

FOUNDATION REPORT

EXCAVATION FOR ST

WITH GEOLOGIC CROSS

AND GEOLOGIC SAM

DATE: JANUARY 1986 PL. NO. 8/14

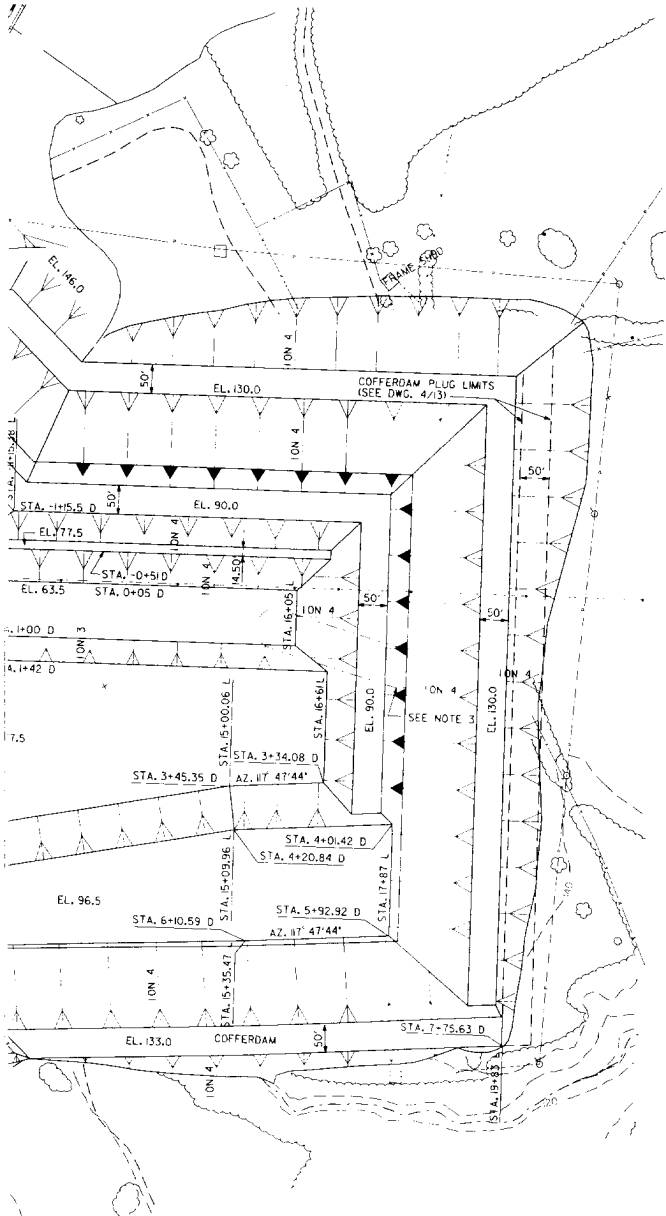

RED RIVER WATERWAY, MISSISSIPPI RIVER, D. SHREVEPORT, LA.
 U.S. ARMY ENGINEER DISTRICT, WORKS BUREAU
 CORPS OF ENGINEERS
 WORKS BUREAU, MISSISSIPPI

LOCK AND DAM NO. 4 FOUNDATION REPORT

EXCAVATION FOR STRUCTURES WITH GEOLOGIC CROSS-SECTION AND GEOLOGIC SAMPLING

DATE: JANUARY 1986

NO. 9-4-206

PLATE 6

LD4-329-93
 STA. -794.0+20D

FIELD BOOK NO. - 7629
 12 MAY 93

LD4-330-93
 STA. +30.4-108D

FIELD BOOK NO. 7629
 12 MAY 93

LD4-331-93
 STA. +99.3-100K

FIELD BOOK NO.
 11 MAY 93

ELEVATION IN FEET A.G.V.D.

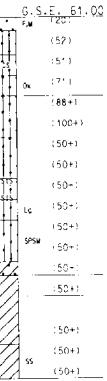
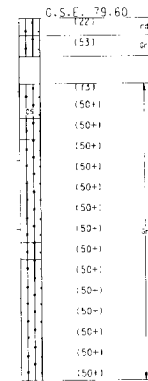
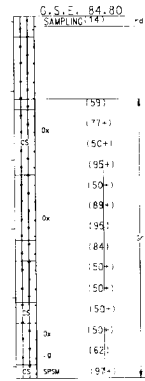

USER IDENT. NO. / JBRZ/FMA / BBT.NOS.
 DESIGN TITLE: DESIGN
 PLOT SCALE: X:1

2

LD4-331-93
 STA. 1+99.3 LOCK; 4+82 DA
 FIELD BOOK NO. - 7629
 11 MAY 93

LD4-332-93
 STA. 56.5L, 629.5D
 FIELD BOOK NO. - 7629
 11 MAY 93

LD4-333-93
 AS ON MAP
 FIELD BOOK NO. - 7629
 18 MAY 93

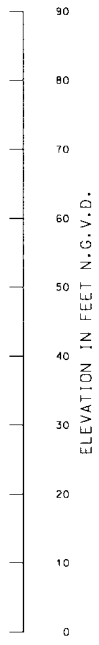
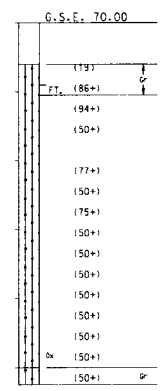
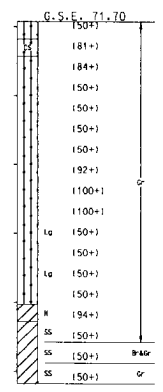
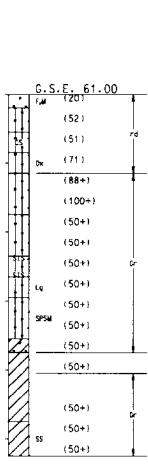

Notes: Borings made by rotary drilling method with cast.
 General samples were taken with a 2.5 inch drive tube.
 Location of borings see plate 6.

RED RIVER WATERWAY-MISSISSIPPI RIVER TO SHREVEPORT, LA.
 U.S. ARMY ENGINEER DISTRICT, VICKSBURG
 CORPS OF ENGINEERS
 VICKSBURG, MISSISSIPPI

LOCK AND DAM NO. 4
 FOUNDATION REPORT
 BORING PROFILES

DATE: JANUARY 1996 FILE NO: R14-286 PLATE 7

UNIFIED SOIL CLASSIFICATION

MAJOR DIVISION	TYPE	LETTER SYMBOL	SYM BOL	TYPICAL NAMES	
COURSE - GRAINED SOILS More than half of material is larger than No. 200 sieve size	GRAVELS More than half of material is larger than No. 4 sieve size.	CLEAN GRAVEL (Little or No Fines)	GW	GRAVEL, Well Graded, gravel-sand mixtures, little or no fines	
		GRAVEL WITH FINES (Appropriate Amount of Fines)	GP	GRAVEL, Poorly Graded, gravel-sand mixtures, little or no fines	
		GRAVEL WITH FINES (Appropriate Amount of Fines)	GM	SILTY GRAVEL, gravel-sand-silt mixtures	
		GRAVEL WITH FINES (Appropriate Amount of Fines)	GC	CLAYEY GRAVEL, gravel-sand-clay mixtures	
	SANDS More than half of material is smaller than No. 4 sieve size.	CLEAN SAND (Little or No Fines)	SW	SAND, Well-Graded, gravelly sands	
		SANDS WITH FINES (Appropriate Amount of Fines)	SP	SAND, Poorly-Graded, gravelly sands	
		SANDS WITH FINES (Appropriate Amount of Fines)	SM	SILTY SAND, sand-silt mixtures	
		SANDS WITH FINES (Appropriate Amount of Fines)	SC	CLAYEY SAND, sand-clay mixtures	
		FINE - GRAINED SOILS More than half of the material is smaller than No. 200 sieve size	SILTS AND CLAYS (Liquid Limit < 50)	ML	SILT & very fine sand, silty or clayey fine sand or clayey silt with slight plasticity
			SILTS AND CLAYS (Liquid Limit < 50)	CL	LEAN CLAY; Sandy Clay; Silty Clays of low to medium plasticity
SILTS AND CLAYS (Liquid Limit < 50)	OL		ORGANIC SILTS and organic silty clays of low plasticity		
SILTS AND CLAYS (Liquid Limit > 50)	MH		SILT, fine sandy or silty soil with high plasticity		
SILTS AND CLAYS (Liquid Limit > 50)	CH		FAT CLAY, Inorganic clay of high plasticity		
SILTS AND CLAYS (Liquid Limit > 50)	OH		ORGANIC CLAYS of medium to high plasticity, organic silts		
HIGHLY ORGANIC SOILS		Pt	PEAT, and other highly organic soil		
WOOD		Wd	WOOD		
NO SAMPLE					

NOTE: Soils possessing characteristics of two groups are designated by combinations of group symbols. A comma will be used between modification symbols. Example, So,Gr,w/SIS,(CH)

DESCRIPTIVE SYMBOLS

COLOR	
COLOR	SYMBOL
TAN	T
YELLOW	Y
RED	R
BLACK	BK
GRAY	GR
LIGHT GRAY	lGr
DARK GRAY	dGr
BROWN	Br
LIGHT BROWN	lBr
DARK BROWN	dBr
BROWNISH - GRAY	br Gr
GRAYISH - BROWN	gy Br
GREENISH - GRAY	gn Gr
GRAYISH - GREEN	gy Gn
GREEN	Gn
BLUE	Bl
BLUE - GREEN	Bl Gn
WHITE	Wh
MOTTLED	Mot
REDDISH	rd

CONSISTENCY FOR COHESIVE SOILS		
CONSISTENCY	COHESION IN LBS./SQ. FT. FROM UNCONFINED COMPRESSION TEST	SYMBOL
VERY SOFT	< 250	vSo
SOFT	250 - 500	So
MEDIUM	500 - 1000	M
STIFF	1000 - 2000	St
VERY STIFF	2000 - 4000	vSt
HARD	> 4000	H

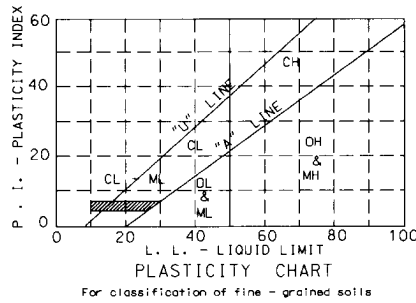

MODIFICATIONS		MODIFICATIONS	
MODIFICATION	SYMBOL	MODIFICATION	SYMBOL
Traces	Tr-	Sandy Silt strata	SSIS
Fine	F	Silty Sand strata	SISS
Medium	M	With	w/
Coarse	C	Dense	D
Concretions	cc	Very Dense	vD
Rootlets	rt		
Lignite fragments	lg		
Shale fragments	sh		
Sandstone fragments	sds		
Shell fragments	sf		
Organic matter	O		
Clay strata or lenses	CS		
Silt strata or lenses	SIS		
Sand strata or lenses	SS		
Sandy	S		
Gravelly	G		
Boulders	B		
Silicified	SL		
Wood	Wd		
Oxidized	Ox		
Crumbly	Cr		
Loose	Lo		
Vegetation	Veg		

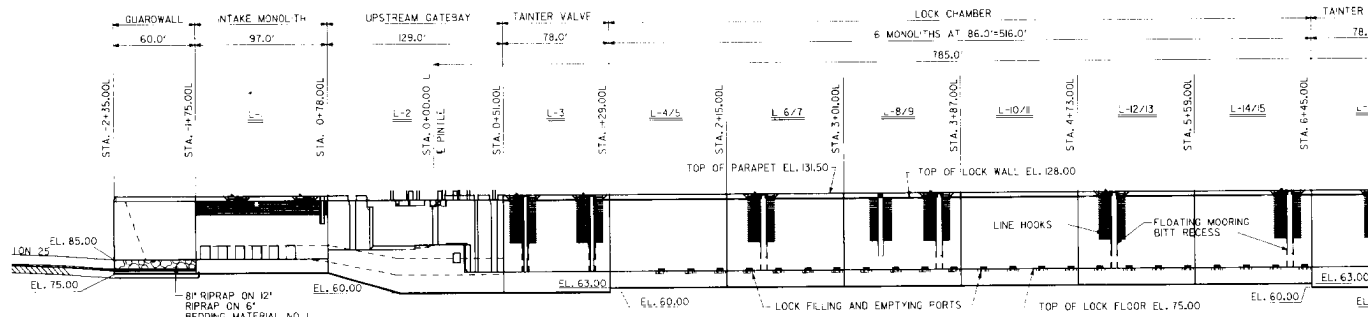
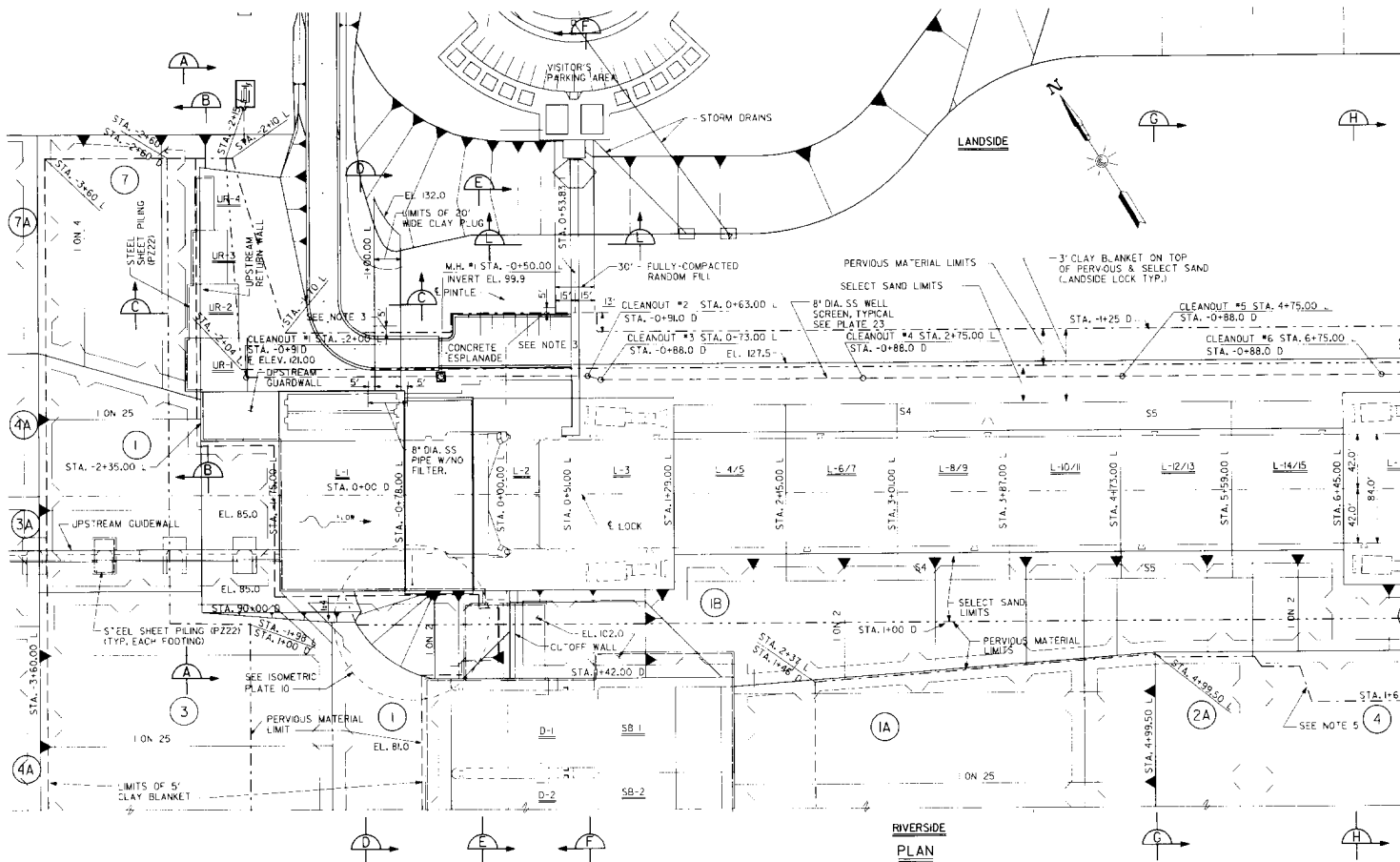

- RIPRAP LEGEND:**
- 1) 8" RIPRAP R7400 ON 12" RIPRAP R90 ON 6" BEDDING MATERIAL NO. 1.
 - 2) 8" RIPRAP R7400 ON 12" RIPRAP R90 ON 24" FILTER MATERIAL.
 - 3) 8" RIPRAP R7400 ON 12" RIPRAP R90 ON ENGINEERING FABRIC ON 24" FILTER MATERIAL.
 - 4) 54" RIPRAP R2200 ON 12" RIPRAP R90 ON 6" BEDDING MATERIAL NO. 1.
 - 5) 48" RIPRAP R5000 ON 12" RIPRAP R90 ON ENGINEERING FABRIC.
 - 6) 36" RIPRAP R6500 ON 12" BEDDING MATERIAL NO. 2.
 - 7) 36" RIPRAP R6500 ON 12" FILTER STONE ON ENGINEERING FABRIC.
 - 8) 30" RIPRAP R4000 ON 12" BEDDING MATERIAL NO. 2.
 - 9) 30" RIPRAP R4000 ON ENGINEERING FABRIC.
 - 10) 16" RIPRAP R2000 ON 6" BEDDING MATERIAL NO. 1.
 - 11) 16" RIPRAP R2000 ON ENGINEERING FABRIC.

- NOTES:**
1. 24" FILTER MATERIAL CONSISTS OF A 6" BOTTOM LAYER OF SAND 'B', A 6" MIDDLE LAYER OF GRAVEL 'C', AND A 12" TOP LAYER OF FILTER STONE.
 2. BACKFILL LIMIT LINES ARE PARALLEL TO THE CENTERLINES OF THE LOCK OR DAM UNLESS OTHERWISE NOTED.
 3. EXTEND THE 3" THICK CLAY BLANKET 5' INTO THE RANDOM FILL ALONG PARALLEL SECTIONS.
 4. ELEV. 127.5 BREAK LINE AND SELECT SAND LIMIT ARE AT STA. 1+00.0
 5. PERVIOUS MATERIAL LIMIT IS AT TOP OF EXCAVATION SLOPE. SEE PLATE 6 FOR LOCATION.
 6. FOR BACKFILL SECTIONS AA THROUGH FF AND LL SEE PLATE 10 FOR BACKFILL SECTIONS GG THROUGH KK SEE PLATE 11.

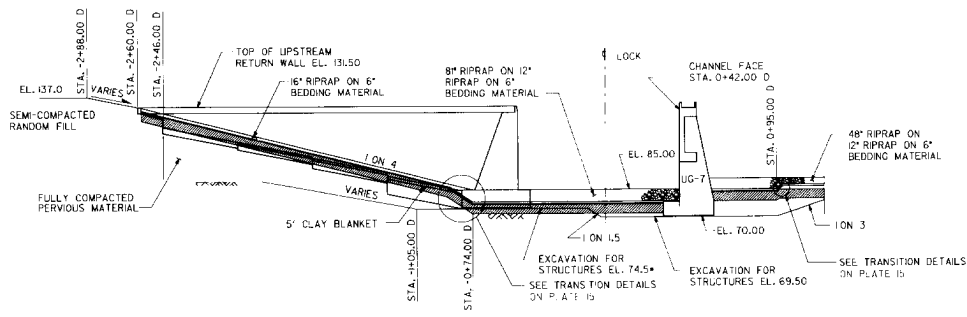

• ADDITIONAL EXCAVATION BENEATH STRUCTURE IS REQUIRED FOR PLACEMENT OF THE CLAY BLANKET

SECTION A

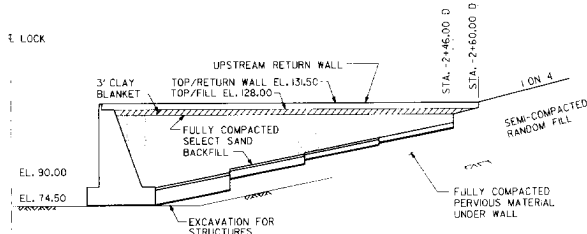

SECTION B

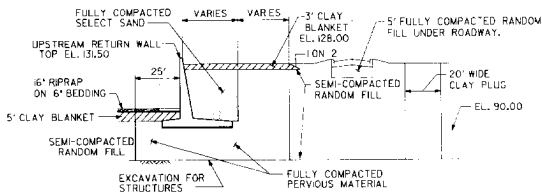

SECTION C

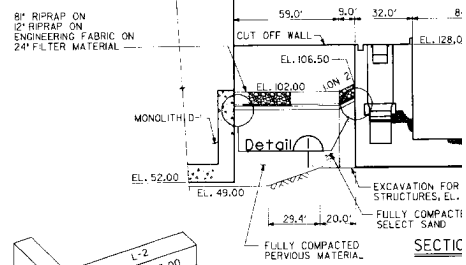
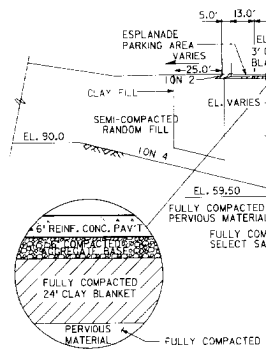
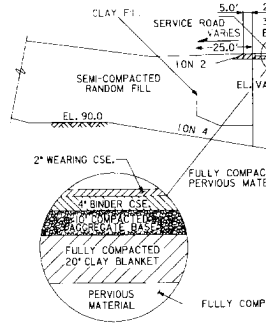

SECTION D

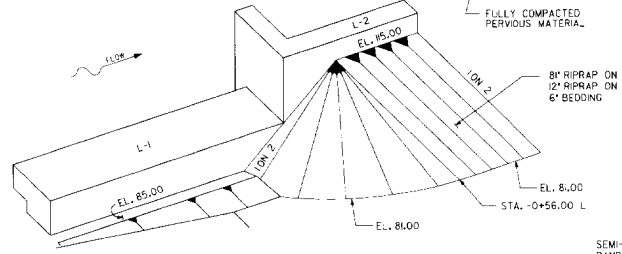

ISOMETRIC VIEW AT L-1 AND L-2 BACKFILL

12/20/2018

SECTION E

2

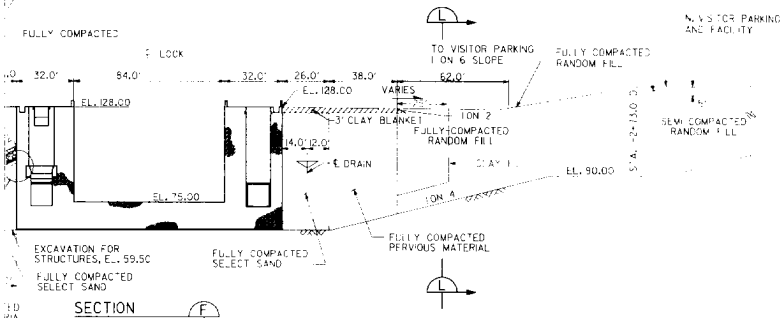
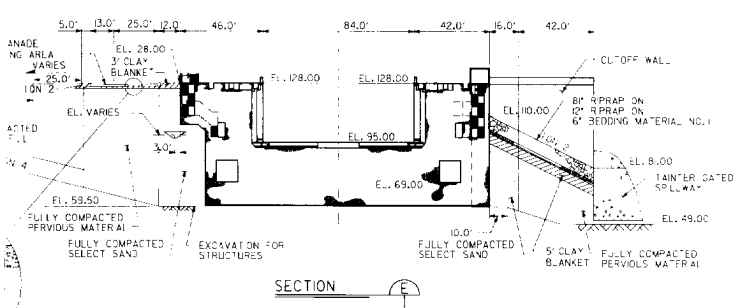
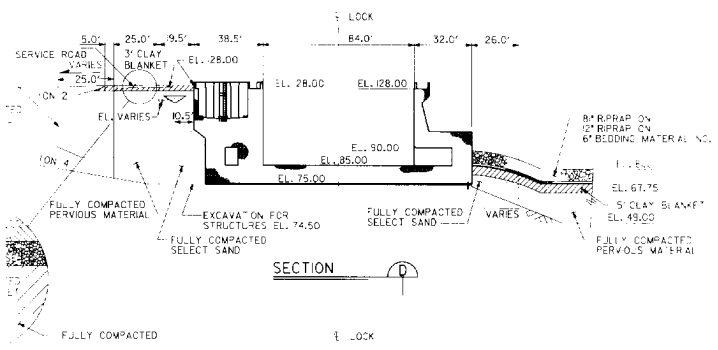

- NOTES:
1. LIMITS OF SELECT SAND BACKFILL ARE FROM STA. +100.00 TO STA. +100.00 D.
 2. SHEET PILING AND 6" STABILIZATION SLAB ARE NOT SHOWN ON THESE SECTIONS FOR CLARITY. SEE SHEET PILE AND STRUCTURAL DRAWINGS FOR THOSE DETAILS.
 3. NEOPRENE COATED NYLON FABRIC AT CLAY BLANKETS NOT SHOWN FOR CLARITY. DRAINS ARE NOT SHOWN FOR CLARITY. FOR LOCATIONS OF SECTIONS SEE PLATE 9.

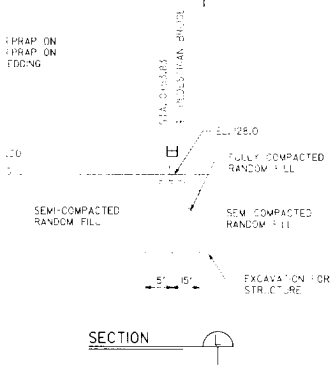

MISSISSIPPI WATERWAY MISSISSIPPI RIVER TO SHREVEPORT, LA.
 U.S. ARMY ENGINEER DISTRICT, VICKSBURG
 CORPS OF ENGINEERS
 VICKSBURG, MISSISSIPPI

LOCK AND DAM NO. 4

FOUNDATION REPORT

LOCK EXCAVATION AND BACKFILL SECTIONS

DATE: JANUARY 1996 FILE NO. R 4-236 PLATE 10

2

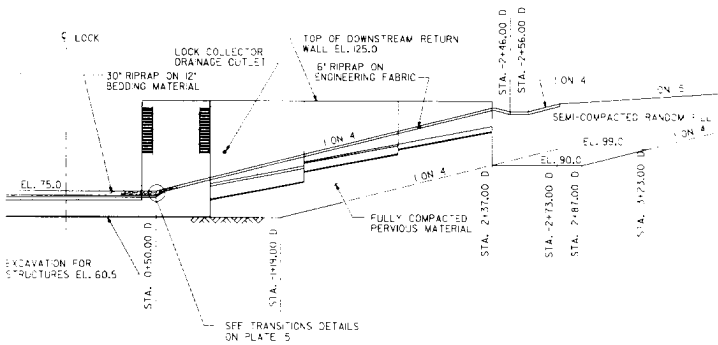

SECTION J

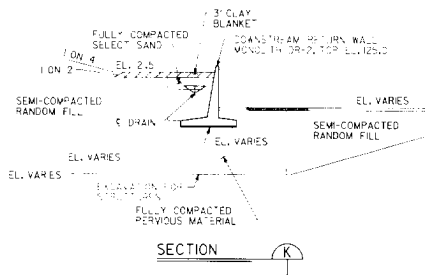

SECTION K

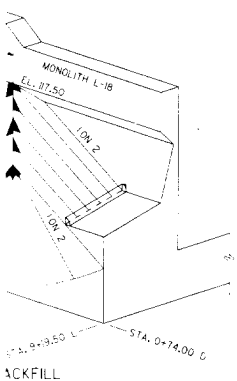

NOTES:
 1. SHEET PILING AND 6\"/>

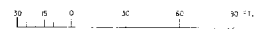

MISSISSIPPI RIVER WATERWAY TO SHREVEPORT, LA.
 U. S. ARMY ENGINEER DISTRICT, VICKSBURG
 CORPS OF ENGINEERS
 VICKSBURG, MISSISSIPPI

LOCK AND DAM NO. 4 FOUNDATION REPORT LOCK EXCAVATION AND BACKFILL SECTIONS

DATE: JANUARY 1996 FILE NO. R-14-206 PLATE

1

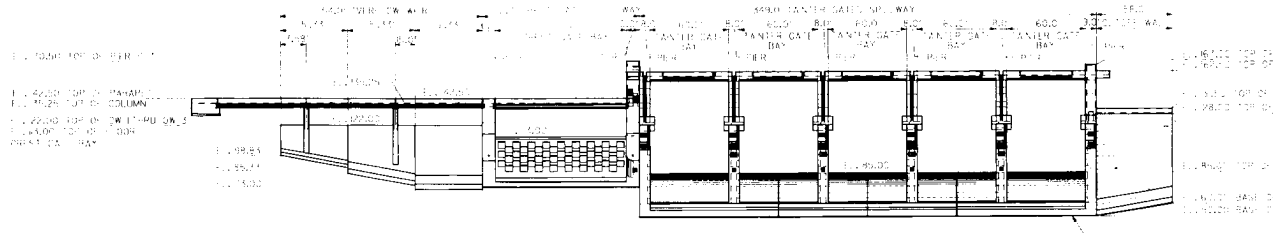
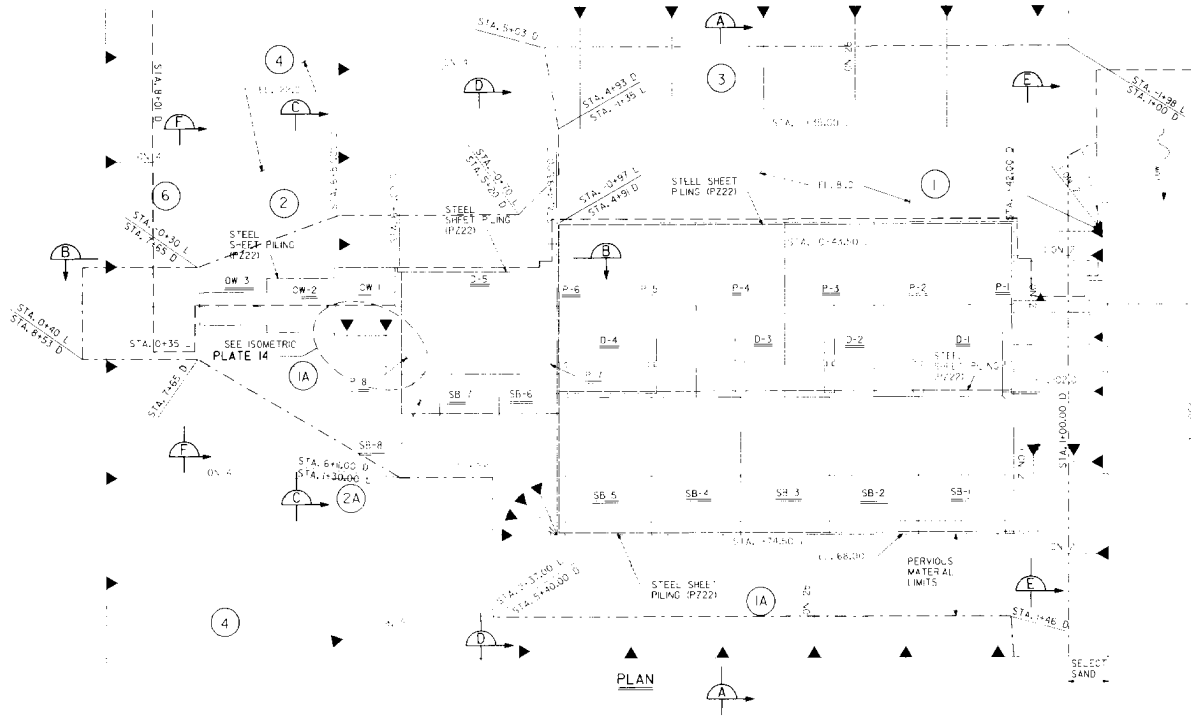

RPRAP LEGEND:

- ① 8" RPRAP 4'X4' ON 2" RPRAP 4'X4' ON 4" RPRAP MATRIAL
- ② 8" RPRAP 4'X4' ON 2" RPRAP 4'X4' ON 4" RPRAP MATRIAL
- ③ 6" RPRAP 4'X4' ON 2" RPRAP 4'X4' ON 4" RPRAP MATRIAL
- ④ 6" RPRAP 4'X4' ON 2" RPRAP 4'X4' ON 4" RPRAP MATRIAL
- ⑤ 4" RPRAP 4'X4' ON 2" RPRAP 4'X4' ON 4" RPRAP MATRIAL
- ⑥ 2" RPRAP 4'X4' ON 2" RPRAP 4'X4' ON 4" RPRAP MATRIAL
- ⑦ 2" RPRAP 4'X4' ON 2" RPRAP 4'X4' ON 4" RPRAP MATRIAL

NOTE:

1. ALL PERVIOUS MATERIAL CONSISTS OF 4" GRANULAR FILL ON 2" RPRAP 4'X4' ON 4" RPRAP MATRIAL. A 1" MUDFLAY OF SAND, 1/2" AND A 1" LAYER OF PERVIOUS MATERIAL SHALL BE PLACED ABOVE PERVIOUS MATERIAL. ALL PERVIOUS MATERIALS SHALL BE PLACED IN THE DOWNSTREAM SIDE OF DAM UNLESS OTHERWISE NOTED. FOR SECTIONS SEE PLATES 13 AND 14

LEGEND:

- 5' CLAY BLANKET LIMITS
- PERVIOUS MATERIAL BACKFILL LIMITS
- SELECT SAND BACKFILL LIMITS
- SHEET PILE

240632

2

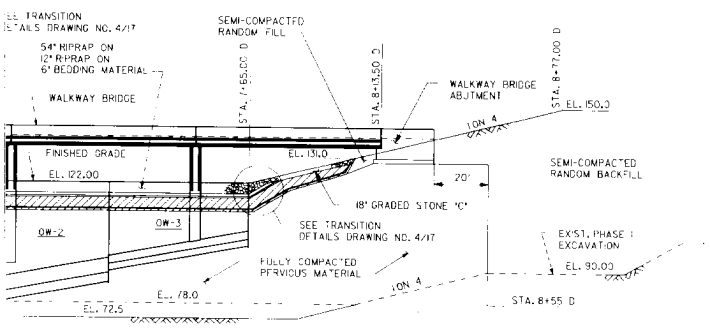
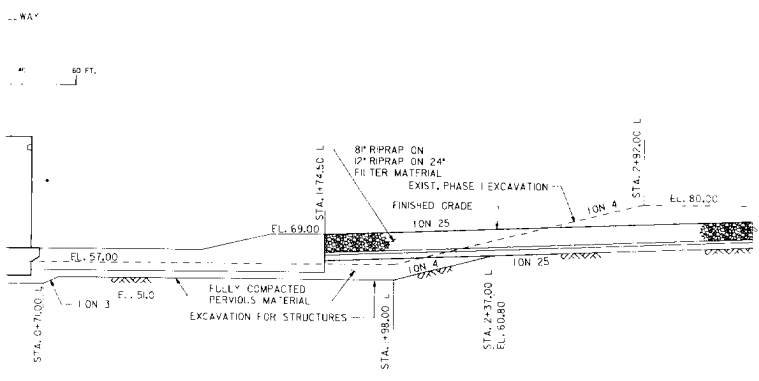

NOTES:
 1. SEE PLATES 19 THROUGH 22 FOR DETAILS OF UNDERDRAIN SYSTEM
 2. SHEET PILING AND 6\"/>

ANCHORS AT 4'-0\"/>

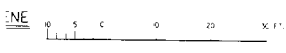

MISSISSIPPI RIVER WATERWAY MISSISSIPPI RIVER TO SARASOTA REPORT, A,
 U.S. ARMY ENGINEER DISTRICT, WICKSBURG
 CORPS OF ENGINEERS
 WICKSBURG, MISSISSIPPI

LOCK AND DAM NO. 4 FOUNDATION REPORT DAM EXCAVATION BACKFILL SECTIONS

DATE: JANUARY 1996 NO. R-4-206 PLATE 13

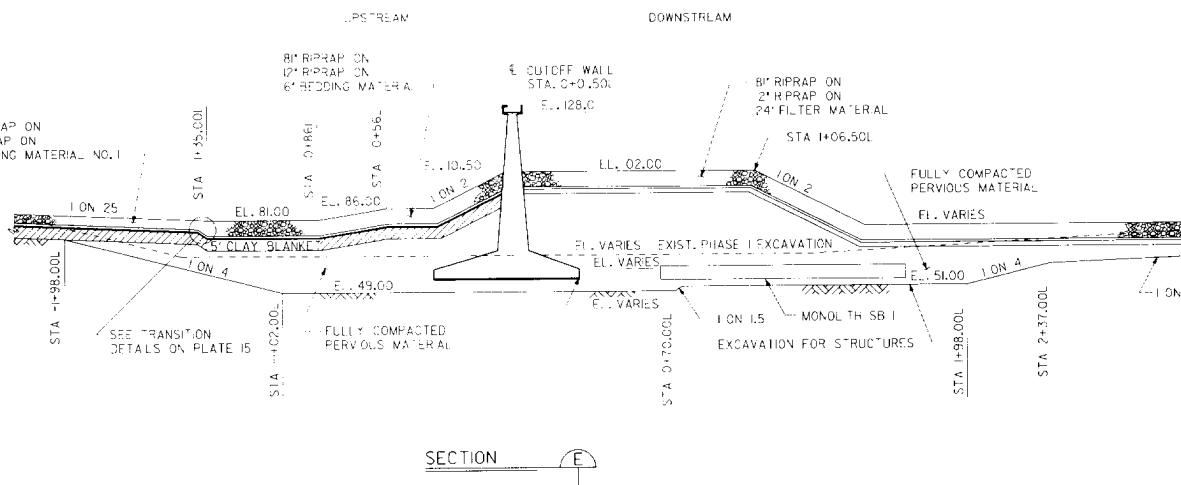
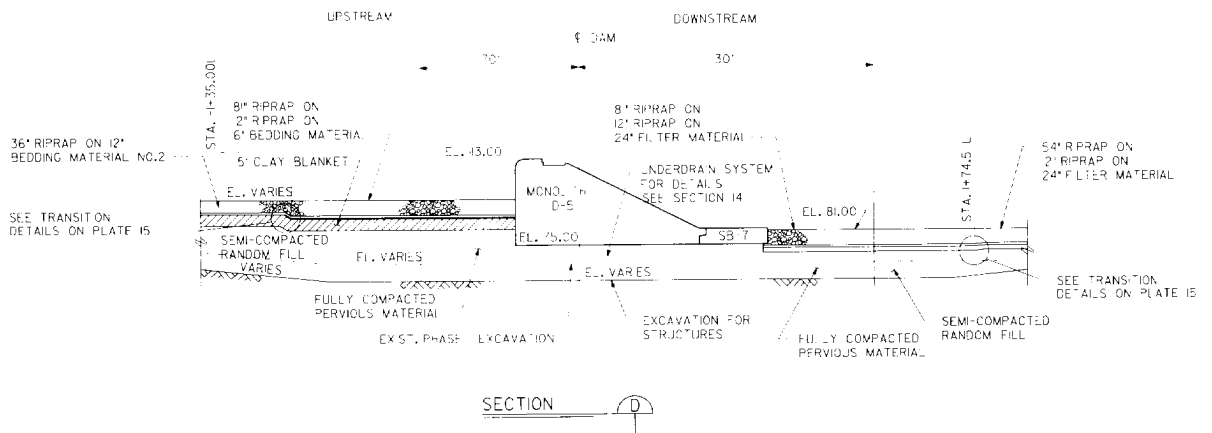
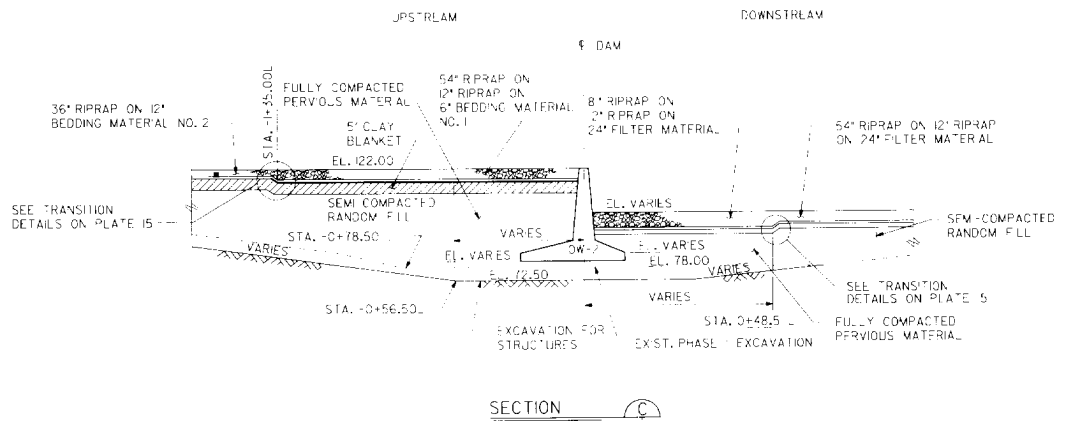

10/27/80

2

ON 12" RIPRAP
OVER MATERIAL.

SEMI-COMPACTED
RANDOM FILL

SITING
ON PLATE 15
FACTED
MATERIAL

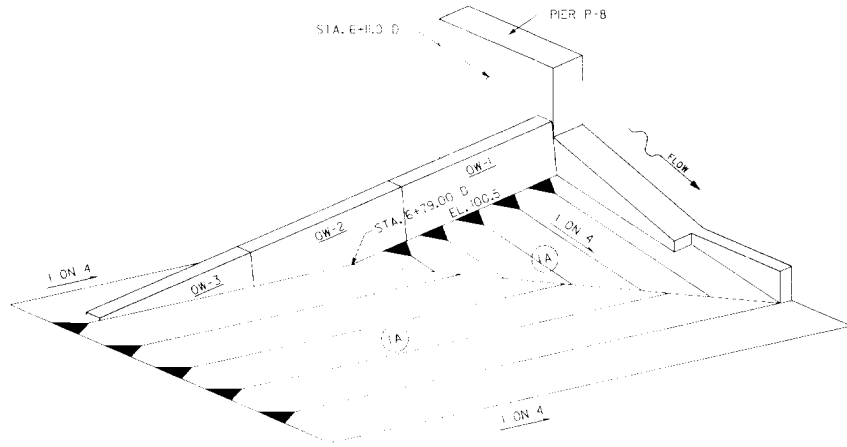

ISOMETRIC VIEW STA. 6+11.00 D BACKFILL

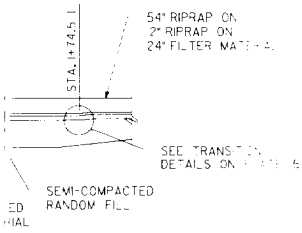

SEMI-COMPACTED
RANDOM FILL

SEMI-COMPACTED
RANDOM FILL

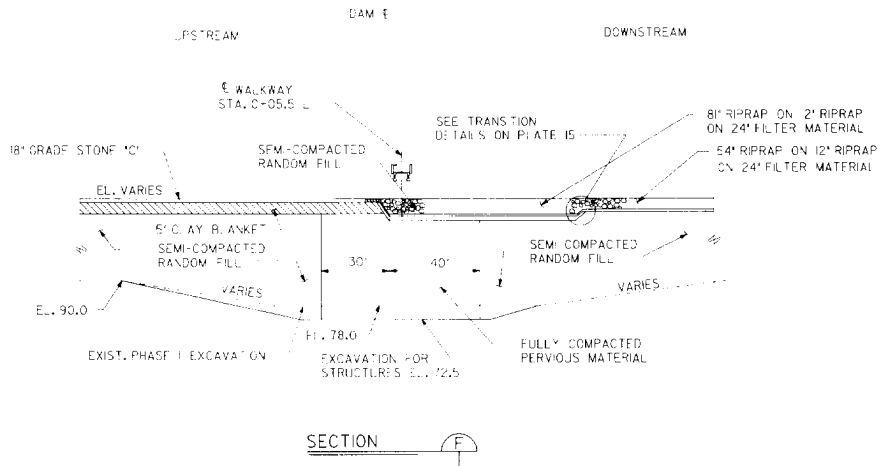
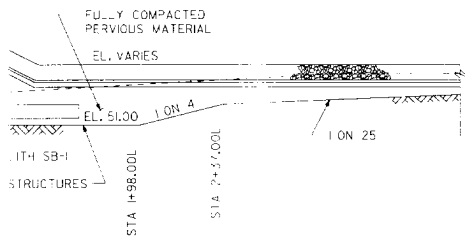

SECTION F-F

- NOTES:
1. SHEET PILING AND 6' STABILIZATION SLAB ARE NOT SHOWN ON THESE SECTIONS FOR CLARITY. SEE SHEET PILE AND STRUCTURAL DRAWINGS FOR THOSE DETAILS.
 2. NEOPRENE COATED NYLON FABRIC AT CLAY BLANKETS NOT SHOWN FOR CLARITY. SEE INSTALLATION DETAILS. SEE PLATE 3.
 3. FOR LOCATION OF SECTIONS SEE PLATE 12.



MISSISSIPPI RIVER WATERWAY
U. S. ARMY ENGINEER DISTRICT, VICKSBURG, MISSISSIPPI
CORPS OF ENGINEERS
VICKSBURG, MISSISSIPPI

LOCK AND DAM FOUNDATION REPAIR DAM EXCAVATION BACKFILL SECTION

DATE: JANUARY 1996 FILE NO. R-14-2

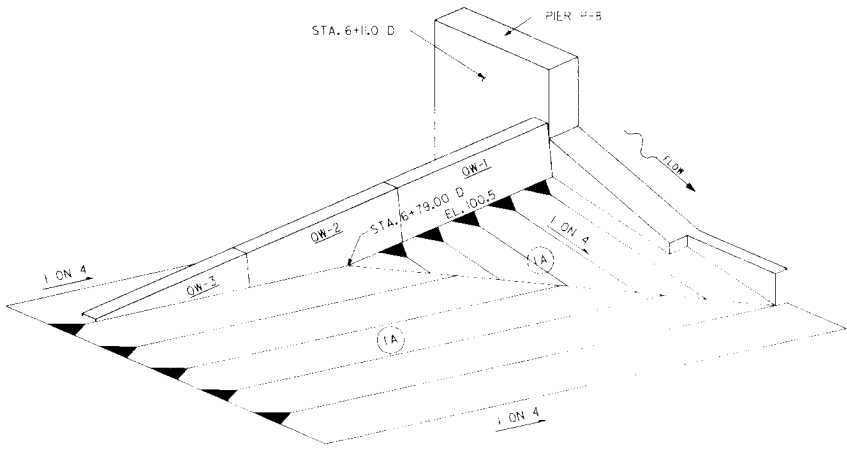

ISOMETRIC VIEW STA. 6+11.00 D BACKFILL

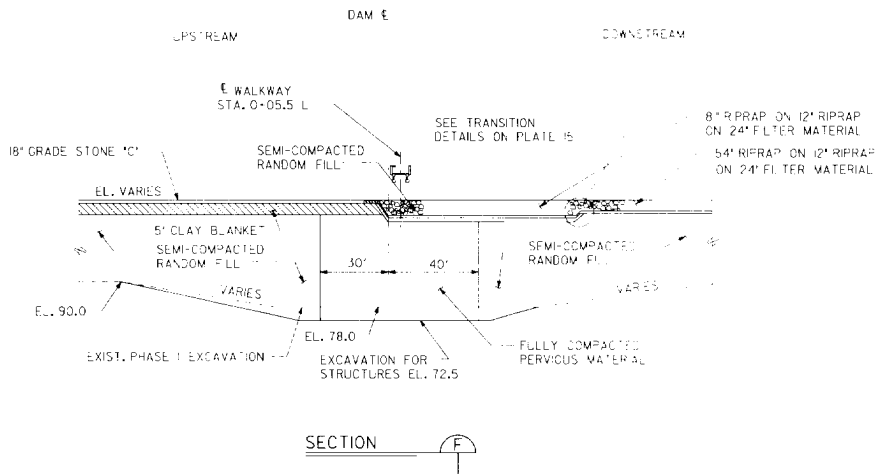

- NOTES:
1. SHEET PILING AND 6\"/>
 2. NEOPRENE COATED NYLON FABRIC AT CLAY BLANKETS NOT SHOWN FOR CLARITY, FOR INSTALLATION DETAILS, SEE PLATE 3.
 3. FOR LOCATION OF SECTIONS SEE PLATE 12.

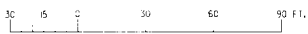

MISSISSIPPI RIVER WATERWAY, MISSISSIPPI RIVER TO SHREVEPORT, LA.
 U.S. ARMY ENGINEER DISTRICT, VICKSBURG
 CORPS OF ENGINEERS
 VICKSBURG, MISSISSIPPI

LOCK AND DAM NO. 4

FOUNDATION REPORT

DAM EXCAVATION BACKFILL SECTIONS

DATE: JANUARY 1996 FILE NO. R-14 206 PLATE 14

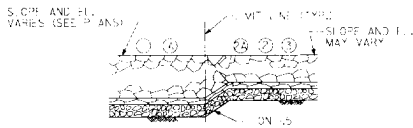

3-3
TRANSITION (NO. 1A) TO 2A)
TRANSITION (NO. 1) TO 2)
TRANSITION (NO. 1) TO 3)

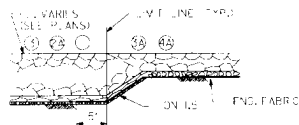

3-2
TRANSITION (NO. 1) TO 3A)
TRANSITION (NO. 1) TO 4A)
TRANSITION (NO. 2A) TO 4A)
TRANSITION (NO. 3) TO 4A)

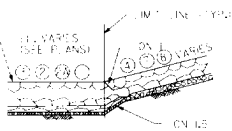

3-2
TRANSITION (NO. 1) TO 7)
TRANSITION (NO. 1) TO 8)
TRANSITION (NO. 2A) TO 4)
TRANSITION (NO. 1) TO 4)
TRANSITION (NO. 2) TO 4)
TRANSITION (NO. 3) TO 4)
TRANSITION (NO. 3) TO 7)

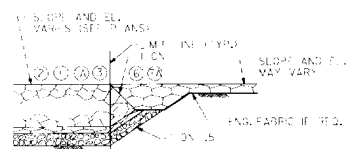

3-1
TRANSITION (NO. 1A) TO 6)
TRANSITION (NO. 1A) TO 7A)
TRANSITION (NO. 1) TO 6)
TRANSITION (NO. 2) TO 6)
TRANSITION (NO. 3) TO 6)

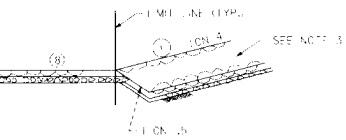

2-3
TRANSITION (NO. 8) TO 1)

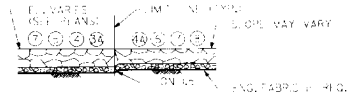

2-2
TRANSITION (NO. 3A) TO 4A)
TRANSITION (NO. 4) TO 5)
TRANSITION (NO. 4) TO 7)
TRANSITION (NO. 5) TO 7)
TRANSITION (NO. 7) TO 8)

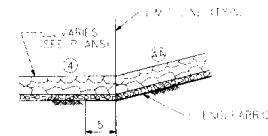

2-2
TRANSITION (NO. 4) TO 4A)

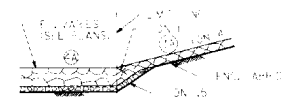

2-1
TRANSITION (NO. 4A) TO 7A)

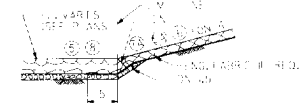

2-1
TRANSITION (NO. 5) TO 5A)
TRANSITION (NO. 5) TO 7A)
TRANSITION (NO. 8) TO 6)

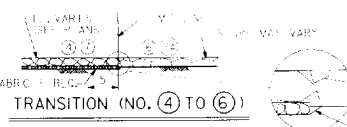

2-1
TRANSITION (NO. 4) TO 6)
TRANSITION (NO. 7) TO 7A)
TRANSITION (NO. 7) TO 6)

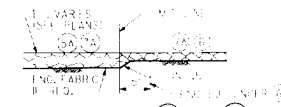

1-1
TRANSITION (NO. 5A) TO 7A)
TRANSITION (NO. 7A) TO 6)

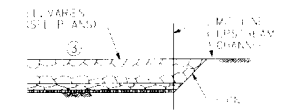

TRANSITION NO. 3 TO CHANNEL BOTTOM TO UPSTREAM CHANNEL

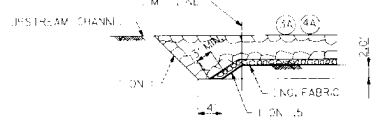

TRANSITION NO. 3A AND 4A TO UPSTREAM CHANNEL

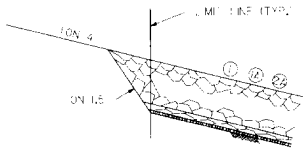

TRANSITION (NO. 1) TO GROUND
 TRANSITION (NO. 1A) TO GROUND
 TRANSITION (NO. 2A) TO GROUND

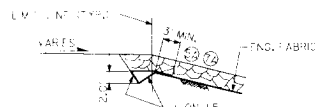

TRANSITION NO. 5A TO GROUND
 TRANSITION NO. 7A TO GROUND

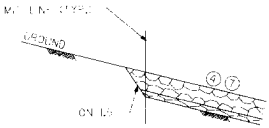

TRANSITION NO. 4 TO GROUND
 TRANSITION NO. 7 TO GROUND

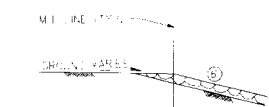

TRANSITION NO. 6 TO GROUND

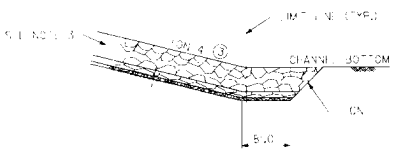

RIPRAP TRENCHFILL 3



TRANSITION (NO. 1) TO GROUND

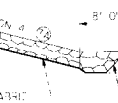

RIPRAP TRENCHFILL

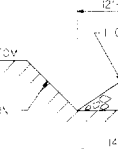

TRENCHFILL

- RIPRAP LEGEND:
- 1 1' TRANK
 - 2 2' TRANK
 - 3 3' TRANK
 - 4 4' TRANK
 - 5 5' TRANK
 - 6 6' TRANK
 - 7 7' TRANK
 - 8 8' TRANK
 - 9 9' TRANK
 - 10 10' TRANK
 - 11 11' TRANK
 - 12 12' TRANK
 - 13 13' TRANK
 - 14 14' TRANK
 - 15 15' TRANK
 - 16 16' TRANK
 - 17 17' TRANK
 - 18 18' TRANK
 - 19 19' TRANK
 - 20 20' TRANK
 - 21 21' TRANK
 - 22 22' TRANK
 - 23 23' TRANK
 - 24 24' TRANK
 - 25 25' TRANK
 - 26 26' TRANK
 - 27 27' TRANK
 - 28 28' TRANK
 - 29 29' TRANK
 - 30 30' TRANK
 - 31 31' TRANK
 - 32 32' TRANK
 - 33 33' TRANK
 - 34 34' TRANK
 - 35 35' TRANK
 - 36 36' TRANK
 - 37 37' TRANK
 - 38 38' TRANK
 - 39 39' TRANK
 - 40 40' TRANK
 - 41 41' TRANK
 - 42 42' TRANK
 - 43 43' TRANK
 - 44 44' TRANK
 - 45 45' TRANK
 - 46 46' TRANK
 - 47 47' TRANK
 - 48 48' TRANK
 - 49 49' TRANK
 - 50 50' TRANK
 - 51 51' TRANK
 - 52 52' TRANK
 - 53 53' TRANK
 - 54 54' TRANK
 - 55 55' TRANK
 - 56 56' TRANK
 - 57 57' TRANK
 - 58 58' TRANK
 - 59 59' TRANK
 - 60 60' TRANK
 - 61 61' TRANK
 - 62 62' TRANK
 - 63 63' TRANK
 - 64 64' TRANK
 - 65 65' TRANK
 - 66 66' TRANK
 - 67 67' TRANK
 - 68 68' TRANK
 - 69 69' TRANK
 - 70 70' TRANK
 - 71 71' TRANK
 - 72 72' TRANK
 - 73 73' TRANK
 - 74 74' TRANK
 - 75 75' TRANK
 - 76 76' TRANK
 - 77 77' TRANK
 - 78 78' TRANK
 - 79 79' TRANK
 - 80 80' TRANK
 - 81 81' TRANK
 - 82 82' TRANK
 - 83 83' TRANK
 - 84 84' TRANK
 - 85 85' TRANK
 - 86 86' TRANK
 - 87 87' TRANK
 - 88 88' TRANK
 - 89 89' TRANK
 - 90 90' TRANK
 - 91 91' TRANK
 - 92 92' TRANK
 - 93 93' TRANK
 - 94 94' TRANK
 - 95 95' TRANK
 - 96 96' TRANK
 - 97 97' TRANK
 - 98 98' TRANK
 - 99 99' TRANK
 - 100 100' TRANK

3

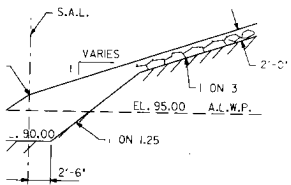

PIERMONT REVETMENT

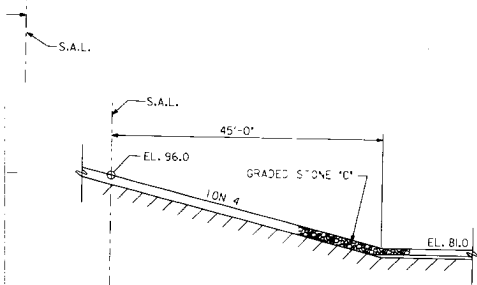

LD4 DOWNSTREAM BANK PAVING

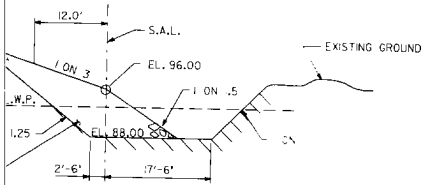

EXISTING CRAIN REVETMENT

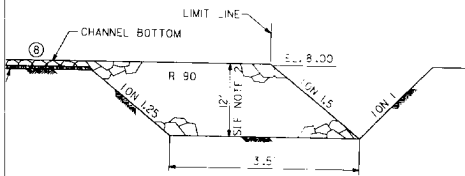

CHANNEL KEY DETAIL

NOTES:

1. THICKNESS OF RRRAP AND BEDDING PLACED SUBSEQUENTLY SHALL BE CONTROLLED BY PLACEMENT SPECIFIED IN SPECIFICATIONS.
2. DEPTH OF CHANNEL KEY AND TRENCHFILL REVETMENT ARE ACTUAL PLACEMENT DEPTHS. NO INCREASE IS REQUIRED FOR SUBSEQUENT PLACEMENT.
3. 8" R7400 AND 48" R500 RRRAP MATERIALS ARE PLACED AT ACTUAL DEPTH WHEN PLACED SUBSEQUENTLY. FOR OTHER MATERIAL PLACEMENT SEE SPECIFICATIONS.
4. FOR PLAN VIEW OF RRRAP SEE PLATE 4.



RED RIVER WATERWAY-MISSISSIPPI RIVER TO SHREVEPORT, LA.
 U. S. ARMY ENGINEER DISTRICT, VICKSBURG
 CORPS OF ENGINEERS
 VICKSBURG, MISSISSIPPI

LOCK AND DAM NO. 4
FOUNDATION REPORT
STONE PROTECTION
DETAILS

DATE: JANUARY 1996

FILE NO. R-14-206

PLATE 15

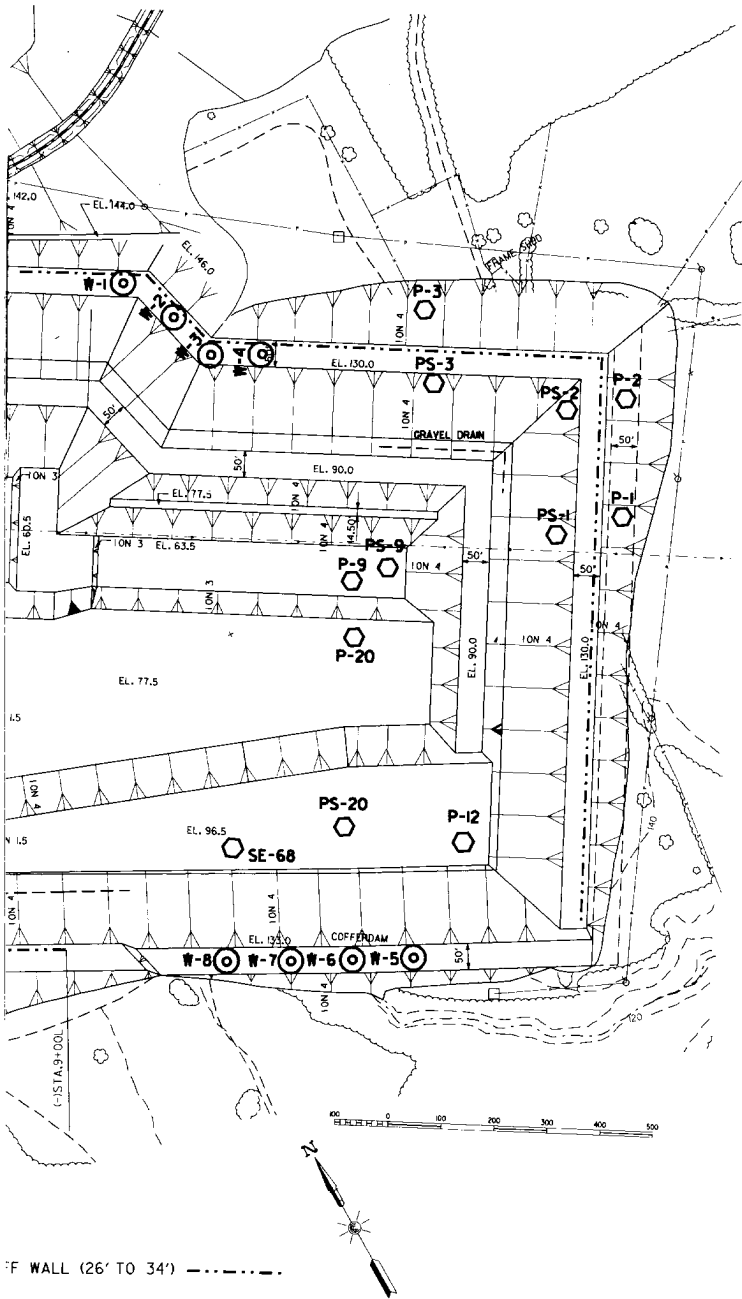

RED RIVER WATERWAY-MISSISSIPPI RIVER TO SHREVEPORT, LA.
 J. S. ARMY ENGINEER DISTRICT, VICKSBURG
 CORPS OF ENGINEERS
 VICKSBURG, MISSISSIPPI

LOCK AND DAM NO. 4 FOUNDATION REPORT

DEWATERING AND MONITORING PLAN

DATE: JANUARY 996 FILE NO. R 14-206 PLATE 16

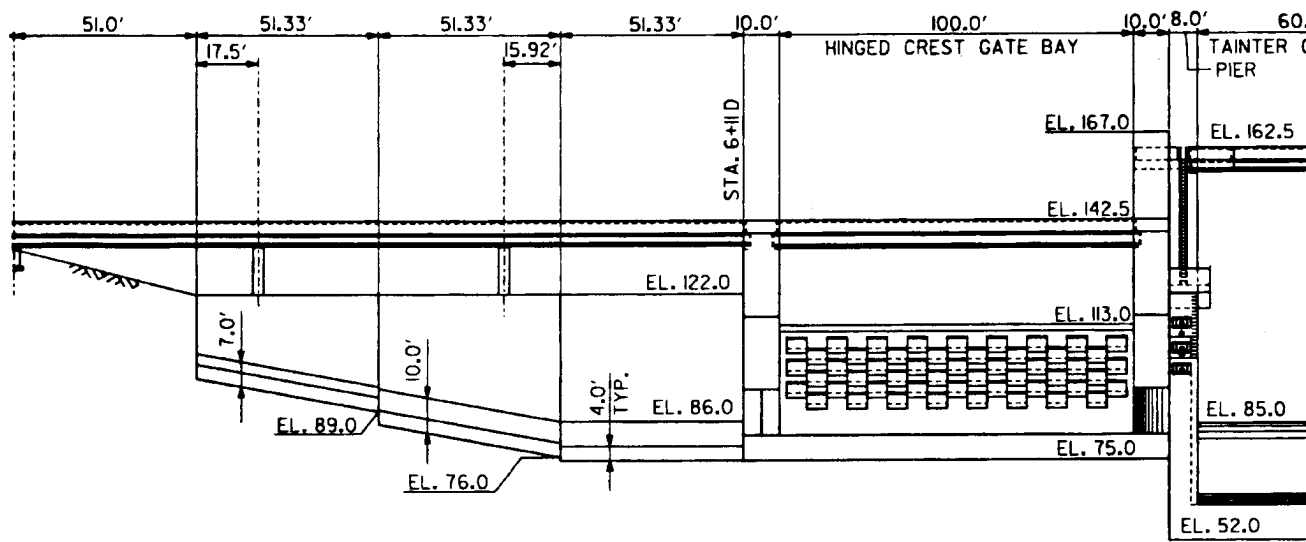

DOWNSTREAM E

SCALE: 1 IN. = 20'

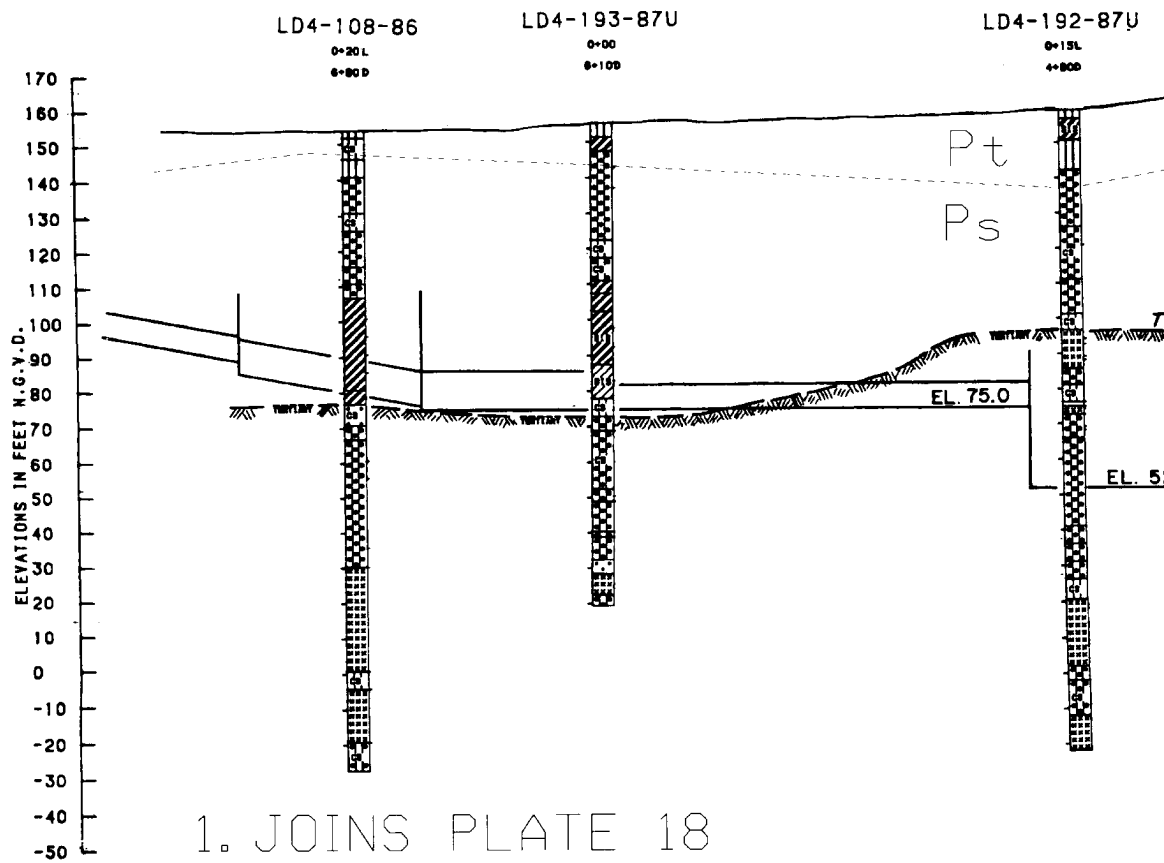

1. JOINS PLATE 18
2. FOR LOCATION OF SECTION SEE
3. Pt; PRAIRIE TOPSTRATUM
 Ps; PRAIRER SUBSTRATUM
 Tw; TERTIARY WILCOX

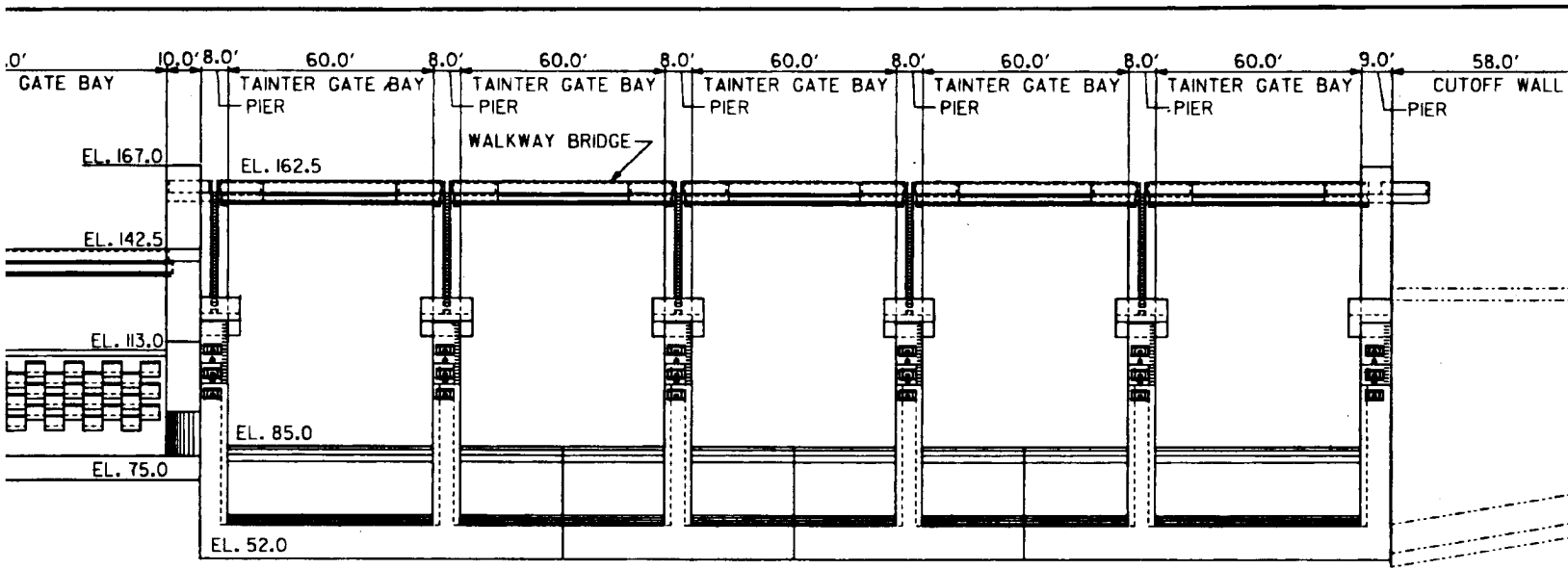

DOWNSTREAM ELEVATION

SCALE: 1 IN. = 20 FT.

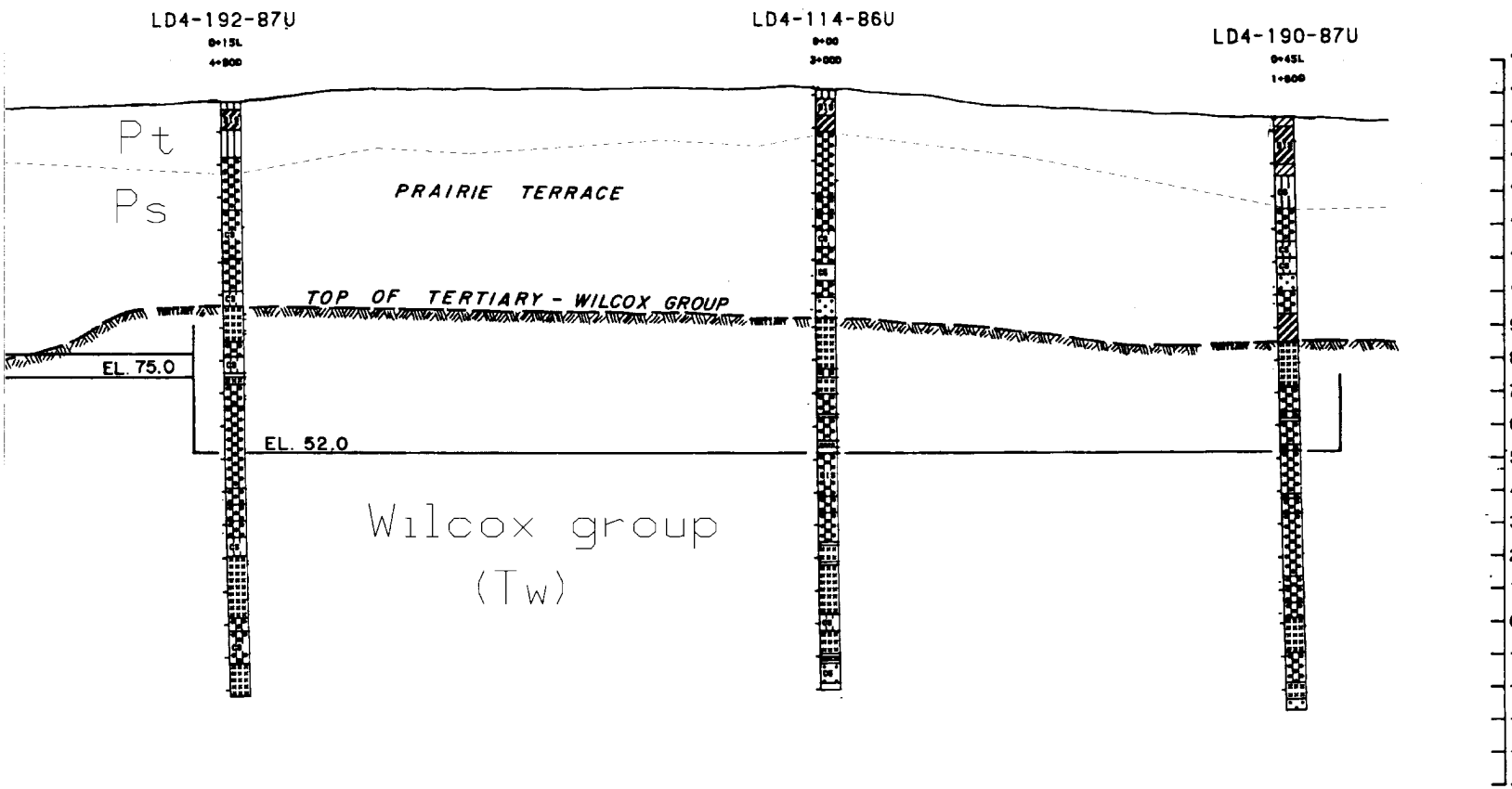

SECTION SEE PLATE 6

ATUM
ATUM

X

2

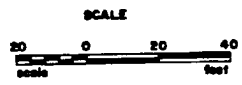

RED RIVER WATERWAY
 L.A. TEL. ARE. & C&L.A.
LOCK AND DAM NO. 4
 MISSISSIPPI RIVER TO SHREVEPORT, LA.

FOUNDATION REPORT
 GEOLOGIC CROSS SECTION

U.S. ARMY ENGINEER DISTRICT, VICKSBURG
 CORPS OF ENGINEERS
 VICKSBURG, MISSISSIPPI

DATE: JANUARY 1996 FILE NO. PLATE 17

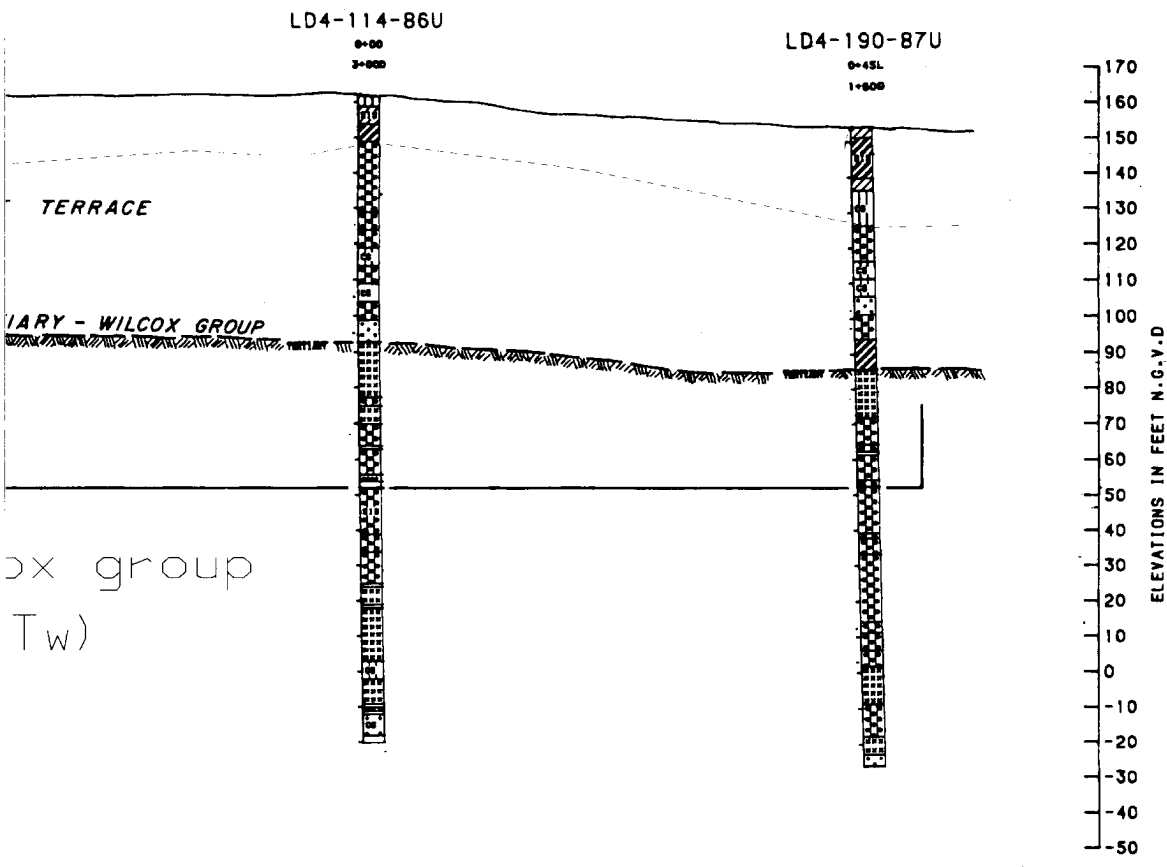
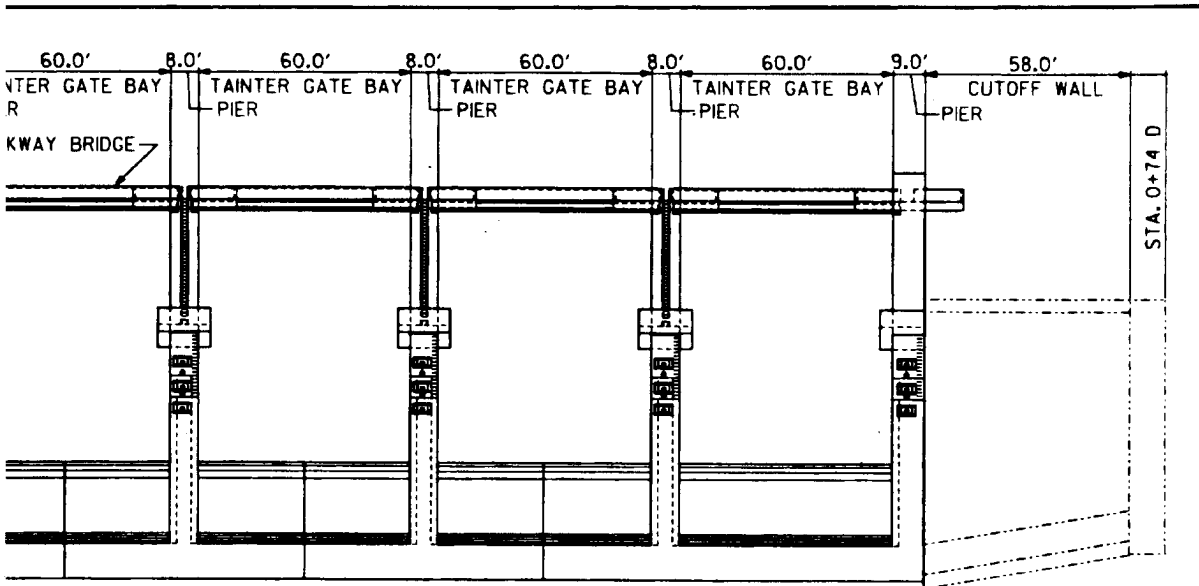

Wilcox group
(Tw)

E 6

RED RIVER WATERWAY
LA, TEX, ARK. & ORLA.

LOCK AND DAM NO. 4
MISSISSIPPI RIVER TO SHREVEPORT, LA.

FOUNDATION REPORT
GEOLOGIC CROSS SECTION

U.S. ARMY ENGINEER DISTRICT, VICKSBURG
CORPS OF ENGINEERS
VICKSBURG, MISSISSIPPI

DATE: JANUARY 1996 PLATE 17 FILE NO. R-14-286

3

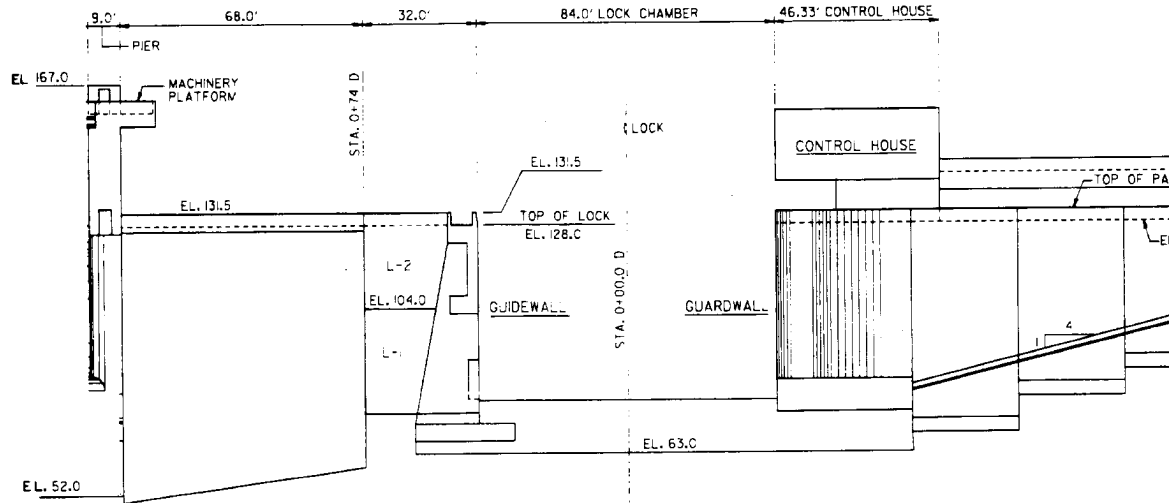

LD4-121-86U

0+00 L
1+10 D

LD4-184-87U

-0+80 L
0+00 D

LD4-134-1

0+00 L
-1+30 D

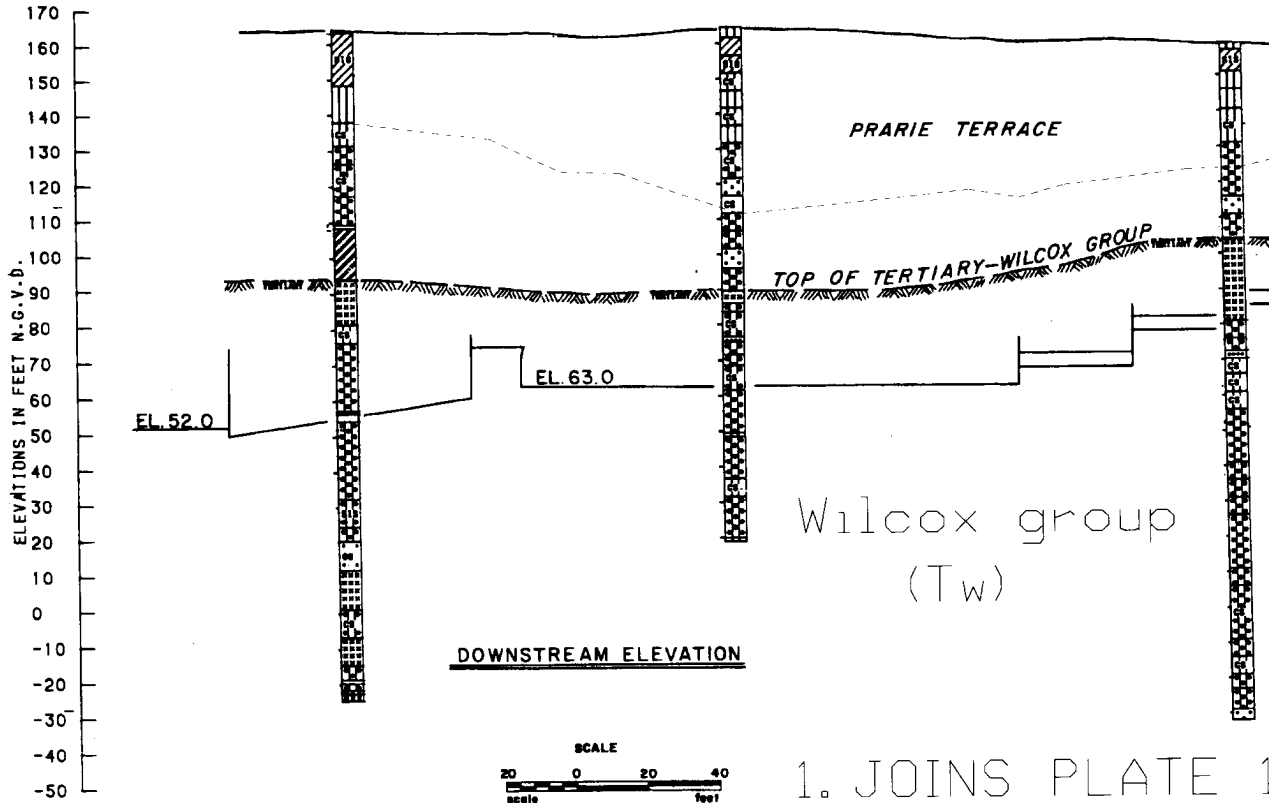

1. JOINS PLATE 1
2. FOR LOCATION
3. Pt: PRAIRIE TO
- Ps: PRAIRER SU
- Tw: TERTIARY WI

HOUSE

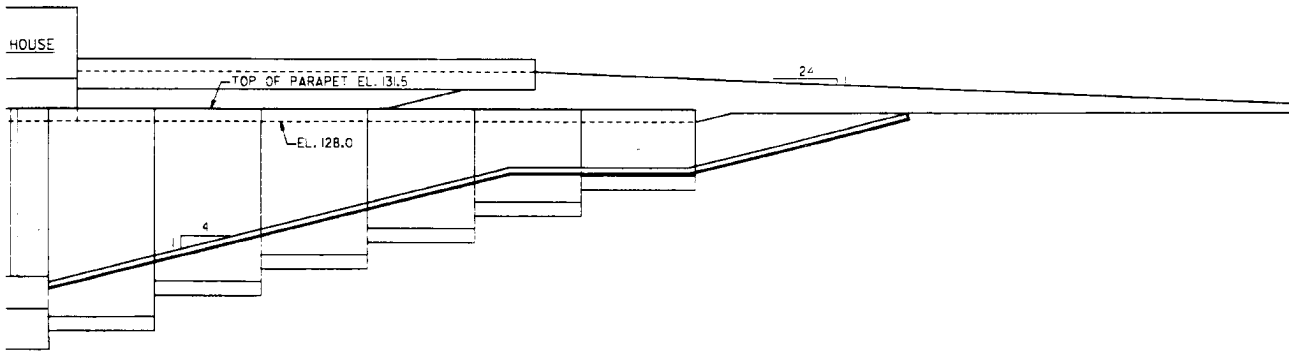

LD4-134-86

0+00 L
-1+30 D

LD4-140-86

0+00 L
-4+00 D

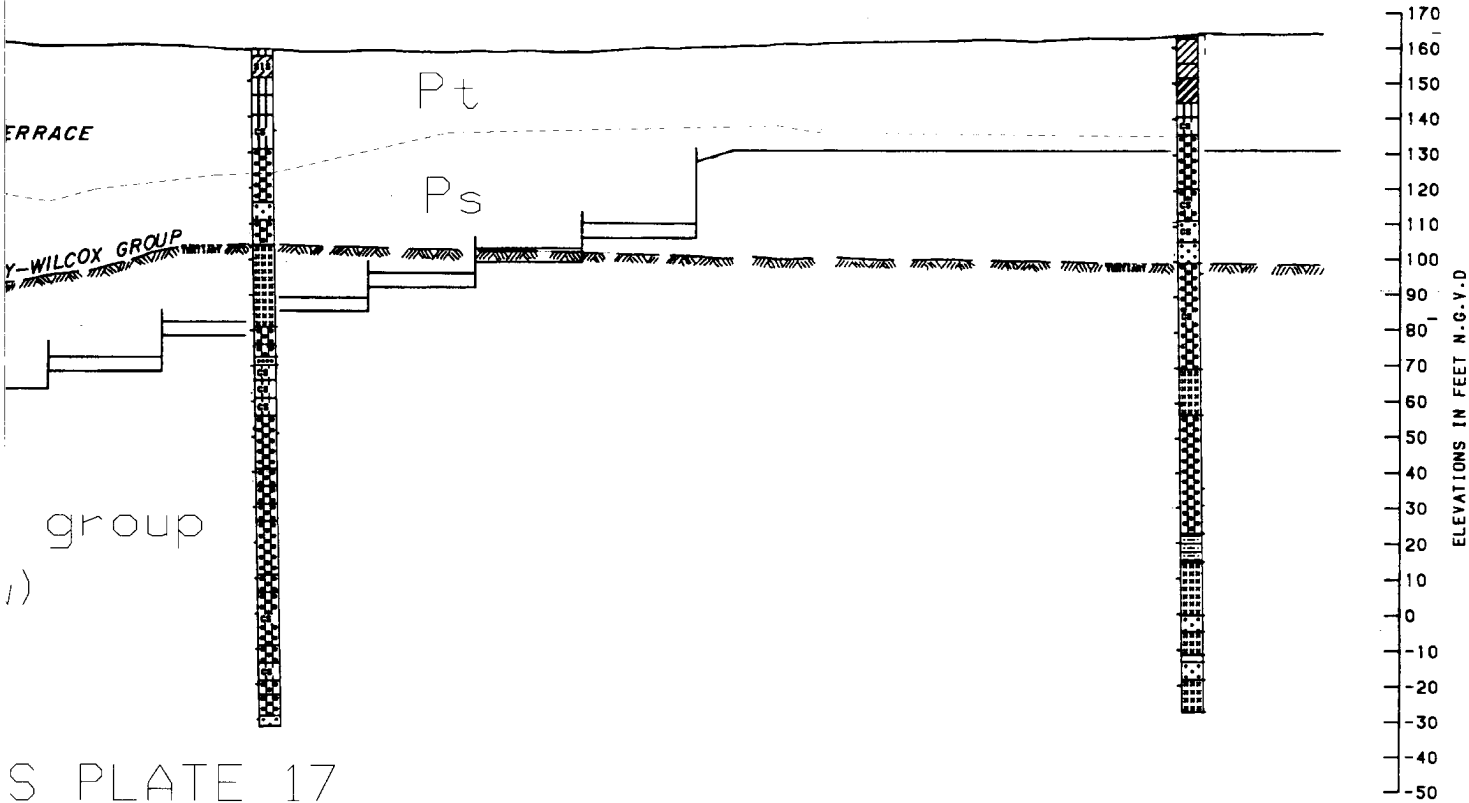

PLATE 17

LOCATION OF SECTIONS SEE PLATE 6

PRAIRIE TOPSTRATUM
PRAIRIER SUBSTRATUM
TERTIARY WILCOX

RED RIVER WATERWAY
LA, TEX, ARK. & OKLA.
LOCK AND DAM NO. 4
MISSISSIPPI RIVER TO SHREVEPORT, LA.

FOUNDATION REPORT
GEOLOGIC CROSS SECTION

U.S. ARMY ENGINEER DISTRICT, VICKSBURG
CORPS OF ENGINEERS
VICKSBURG, MISSISSIPPI

DATE: JANUARY 1996 PLATE 18 FILE NO.: R-1

2

5

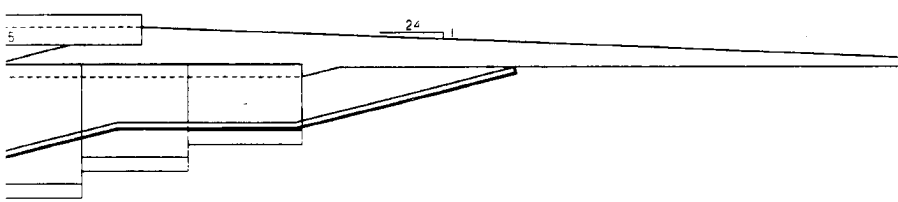

LD4-140-86

0+00 L
-4+00 D

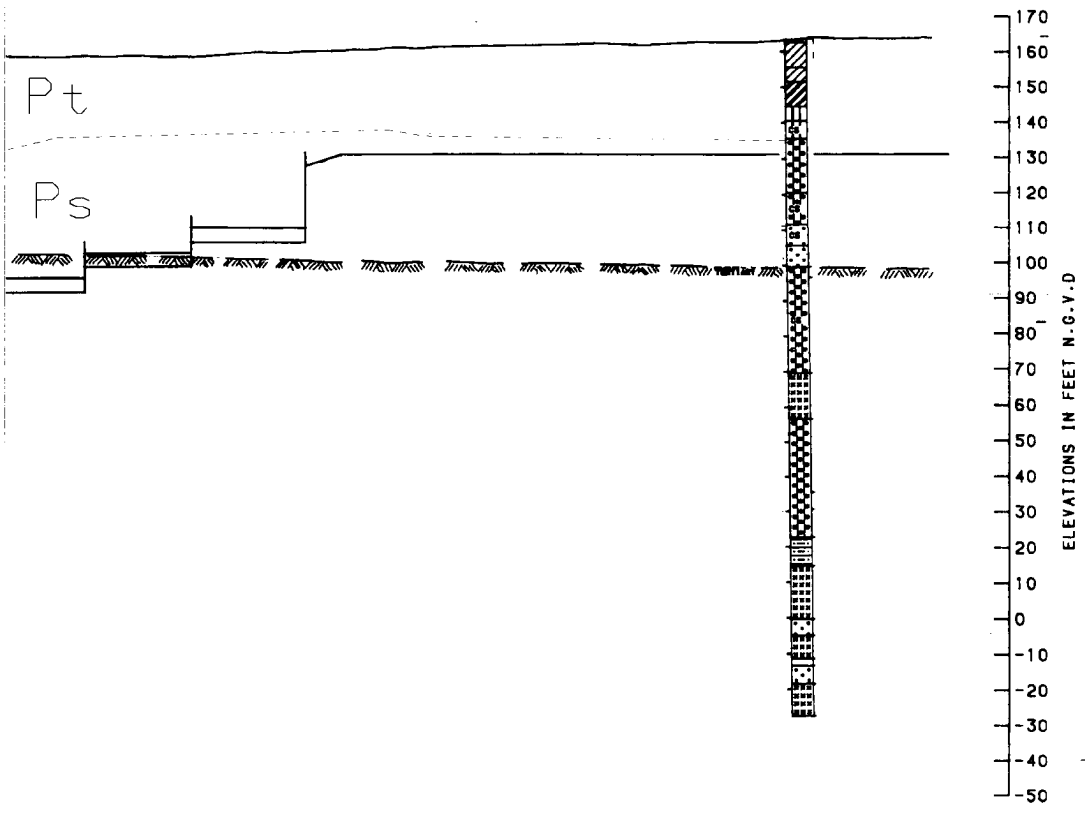

SECTIONS SEE PLATE 6

TRATUM
TRATUM
XX

RED RIVER WATERWAY
LA, TEX, ARK. & OKLA.
LOCK AND DAM NO. 4
MISSISSIPPI RIVER TO SHREVEPORT, LA.

FOUNDATION REPORT
GEOLOGIC CROSS SECTION

U.S. ARMY ENGINEER DISTRICT, VICKSBURG
CORPS OF ENGINEERS
VICKSBURG, MISSISSIPPI

DATE: JANUARY 1996 PLATE 18 FILE NO. R-14-206

3

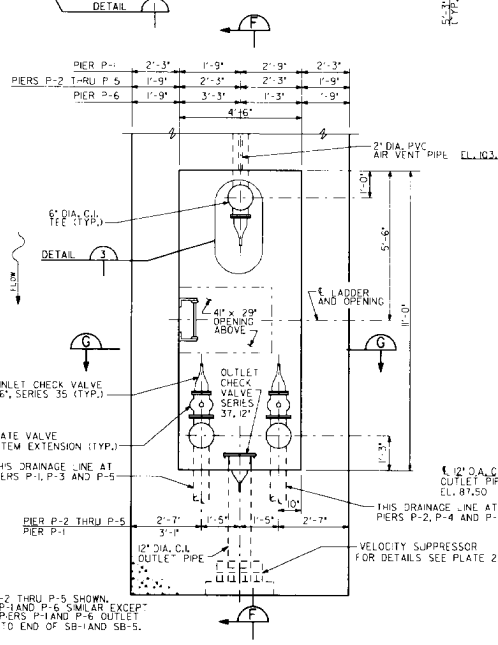
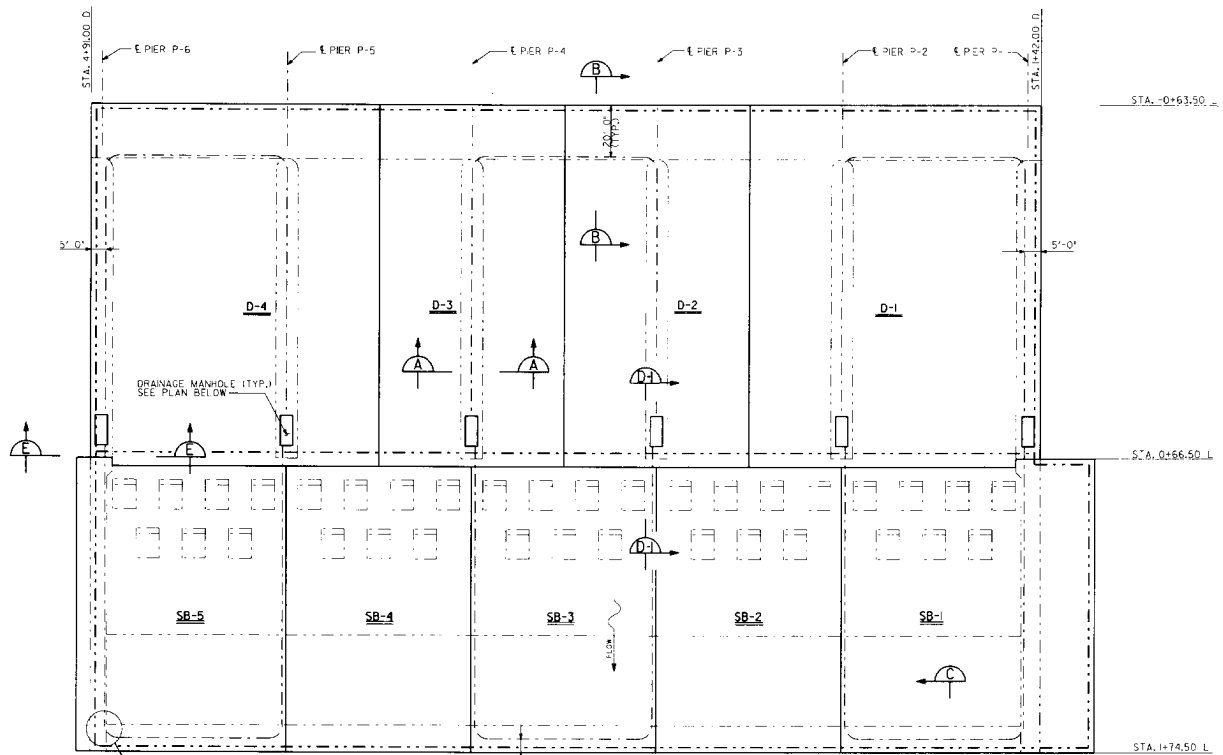

NOTES:
 MANHOLES AT P-2 THRU P-5 SHOWN.
 MANHOLES AT P-1 AND P-6 SIMILAR EXCEPT
 AS NOTED AT PERS P-1 AND P-6. OUTLET
 PIPE EXTENDS TO END OF SB-1 AND SB-5.

MANHOLE SECTIONAL PLAN

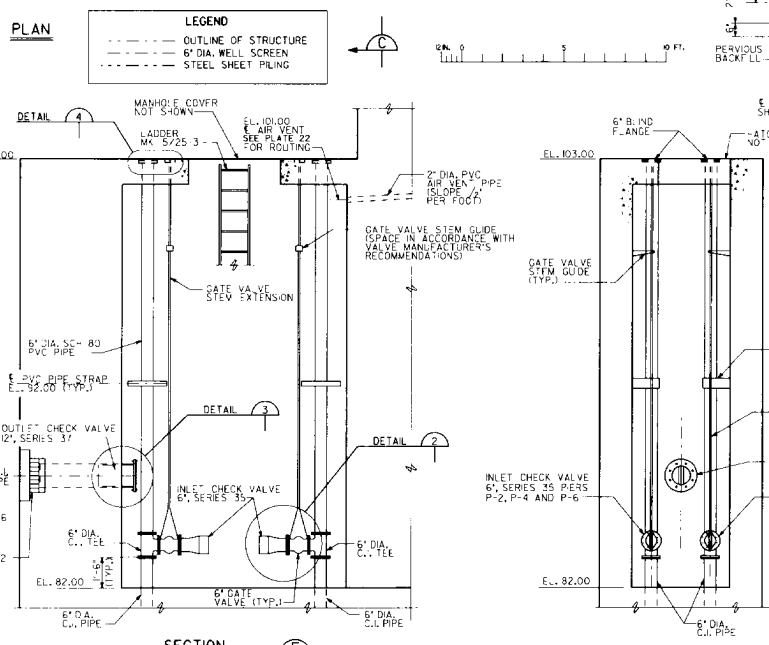
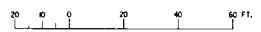

SECTION

SECTION

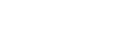
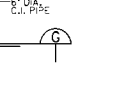
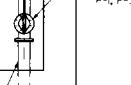
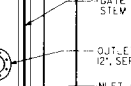
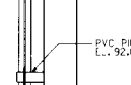
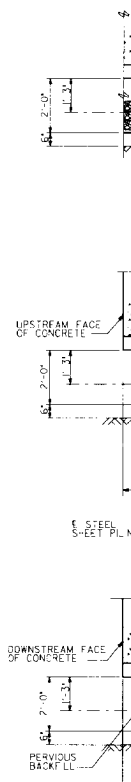
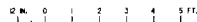

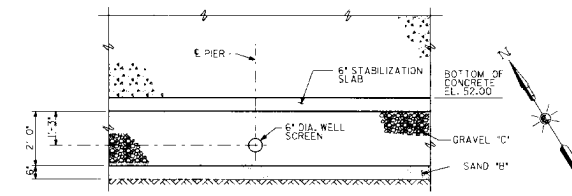
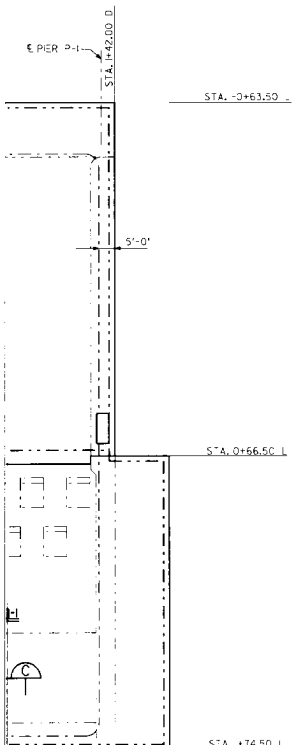

SECTION A
NOTE: TYPICAL AT PIERS P-2 THRU P-5.

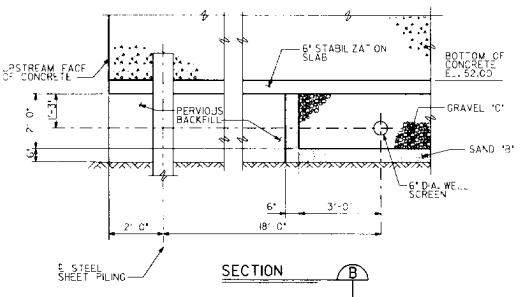

SECTION B

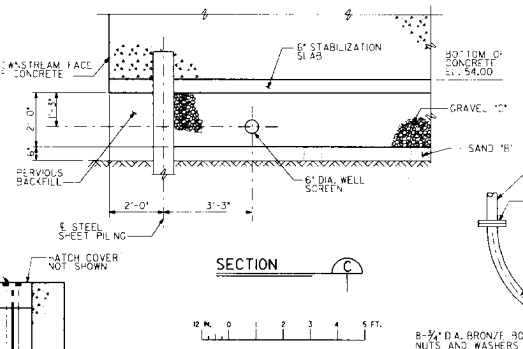

SECTION C

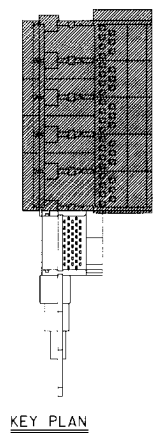

KEY PLAN

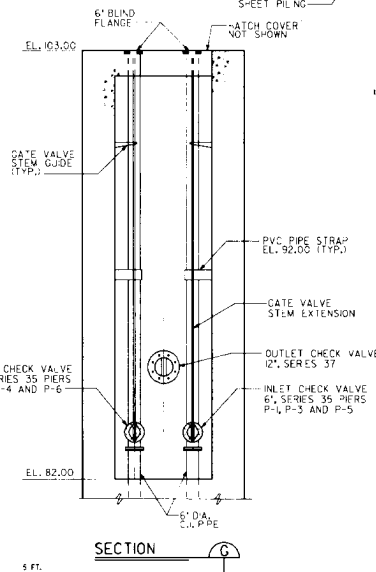
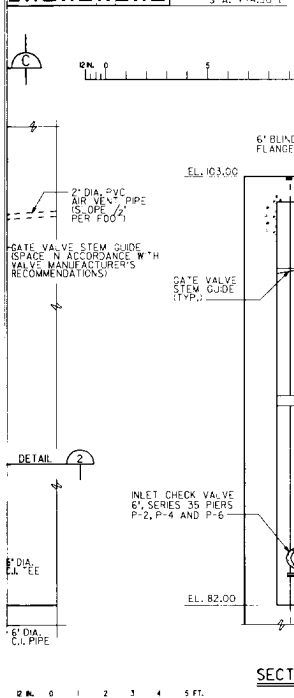

SECTION D

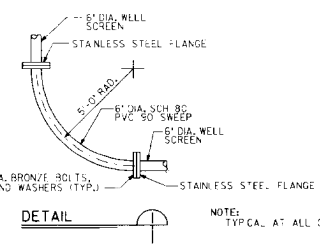

DETAIL

NOTE: TYPICAL AT ALL CORNERS.

- NOTES:
1. CHECK VALVES SHALL BE FASTENED TO FLANGED PIPE WITH STAINLESS STEEL NUTS AND BOLTS.
 2. CHECK VALVES SHALL BE INSTALLED WITH THE RUBBER DUCKBILL IN A VERTICAL POSITION.
 3. ALL 6 INCH WELL SCREENS ARE #20 SICT. STAINLESS STEEL WIRE WRAPPED
 4. FOR SECTION D-D SEE PLATE 2.
 5. FOR SECTION E-E SEE PLATE 2.

RED RIVER WATERWAY - MISSISSIPPI
 J. S. ARMY ENGINEER DIST
 CORPS OF ENGINEERS
 VICKSBURG, MISSISSIPPI

**LOCK AND DAM FOUNDATION
 MONOLITHS AND UNDERDRAIN
 PLANS, SECTIONS A**

DATE: JANUARY 1996 FILE

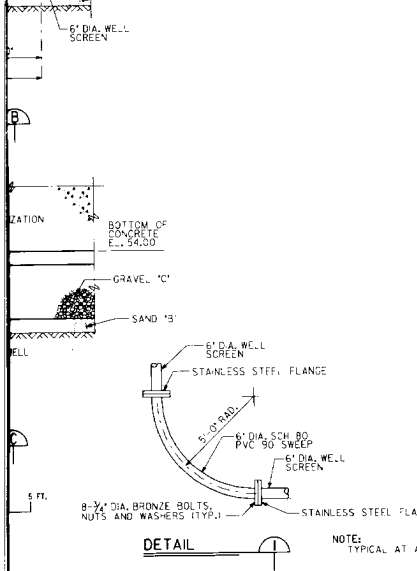
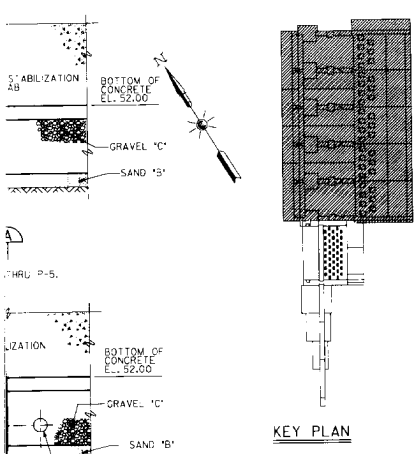

ALL SHALL BE FASTENED
PIPE WITH STAINLESS
AND BOLTS.
ALL SHALL BE INSTALLED
PER DUCKBILL IN
POSITION.
ALL SCREENS ARE #20 SLOT,
WEL WIRE WRAPED
SEE PLATE 2.
SEE PLATE 22

RED RIVER WATERWAY-MISSISSIPPI RIVER TO SHREVEPORT, LA.
U. S. ARMY ENGINEER DISTRICT, VICKSBURG
CORPS OF ENGINEERS
VICKSBURG, MISSISSIPPI

LOCK AND DAM NO. 4
FOUNDATION REPORT
MONOLITHS D-1 THRU D-4
UNDERDRAIN SYSTEM
PLANS, SECTIONS AND DETAILS

DATE: JANUARY 1996 FILE NO. R-14-206 PLATE 19

3

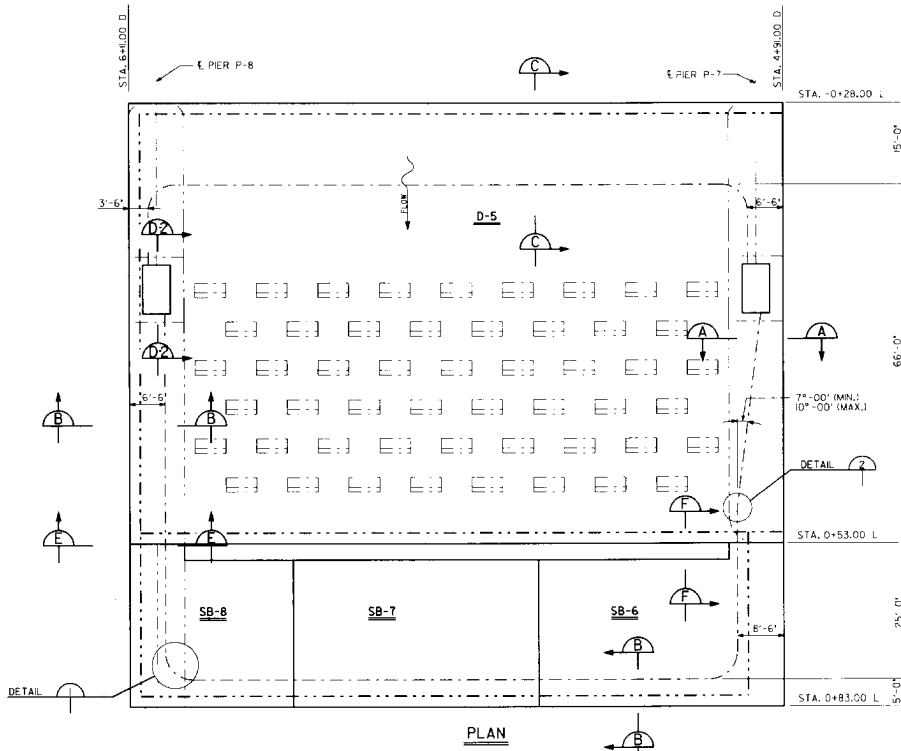

PLAN

LEGEND	
---	OUTLINE OF STRUCTURE
---	6" DIA. WELL SCREEN
---	STEEL SHEET PILING

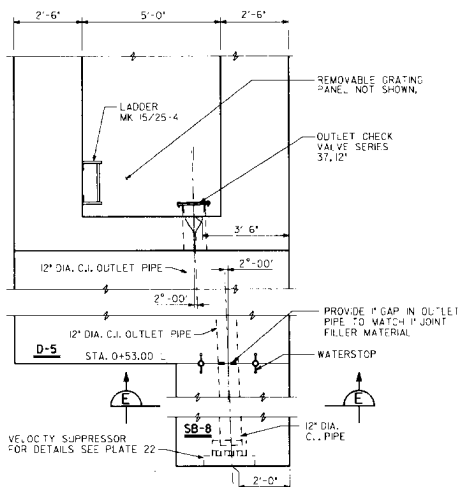

PARTIAL PLAN - MANHOLE AT PIER P-8

NOTE:
LOCATIONS OF DRAINAGE LINES AND INLET CHECK VALVES
ARE SIMILAR TO MANHOLE AT PIER P-7.

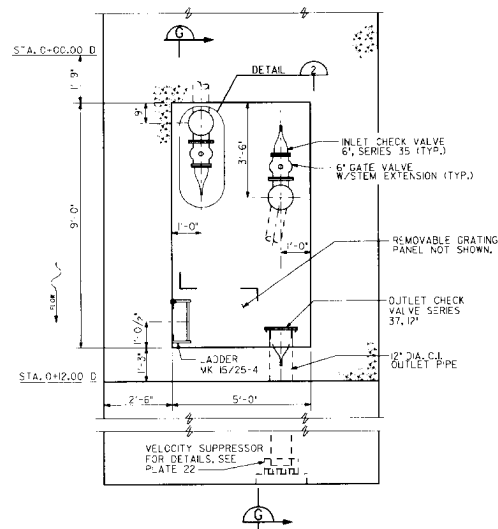
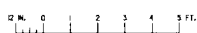

SECTIONAL PLAN - MANHOLE AT PIER P-7

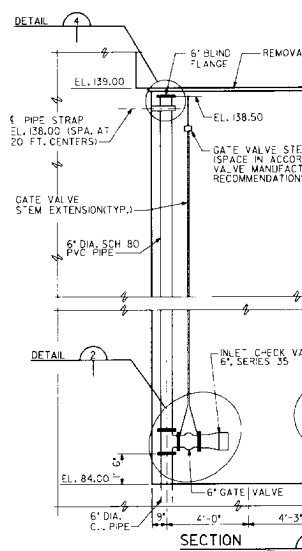
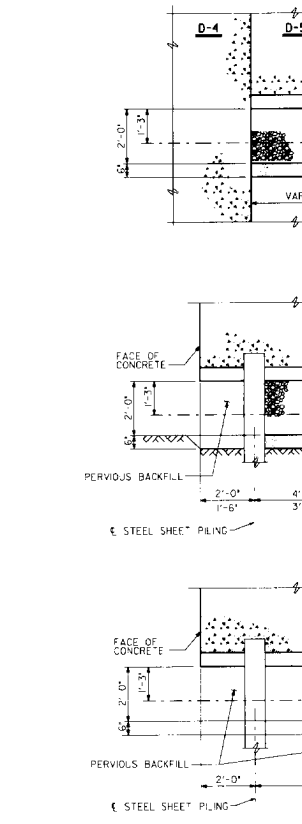

SECTION

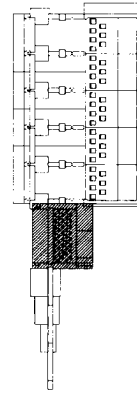
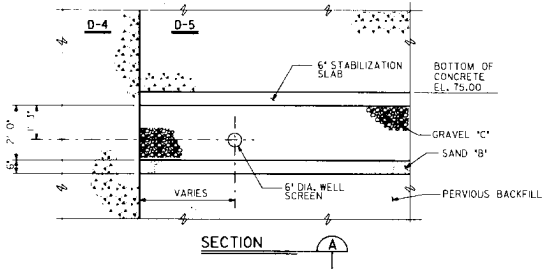

KEY PLAN

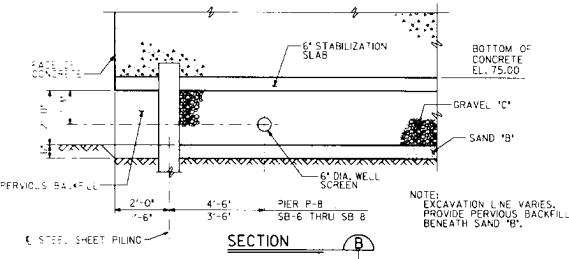

SECTION B

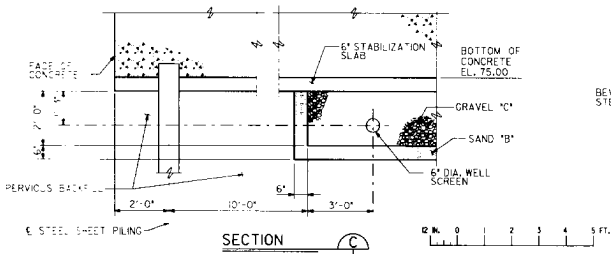

SECTION C

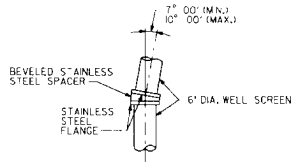

DETAIL 2

NOTE.
FOR SECTION D2-D2 SEE PLATE 21
FOR SECTION E-E SEE PLATE 22

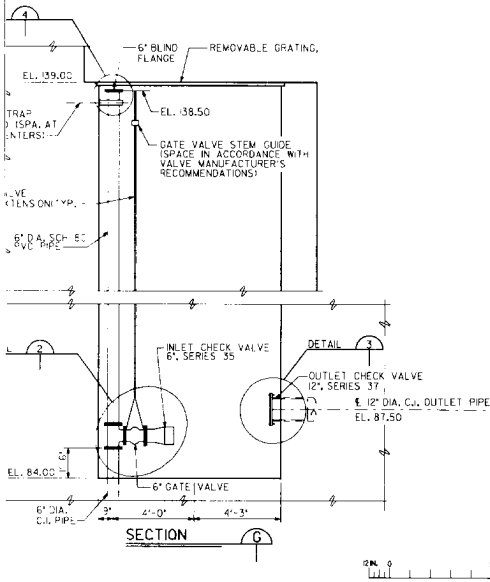

SECTION D



RED RIVER WATERWAY-MISSISSIPPI RIVER TO SHREVEPORT, L.A.
U. S. ARMY ENGINEER DISTRICT, VICKSBURG
CORPS OF ENGINEERS
VICKSBURG, MISSISSIPPI

LOCK AND DAM NO. 4.
FOUNDATION REPORT
CREST GATED SPILLWAY
MONOLITH D-5
UNDERDRAIN SYSTEM
PLANS, SECTIONS AND DETAILS

DATE: JANUARY 1996 FILE NO. R-14-206 PLAT

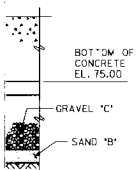
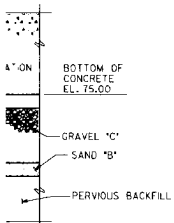

NOTE:
EXCAVATION LINE VARIES.
PROVIDE PERVIOUS BACKFILL
BENEATH SAND 'B'.

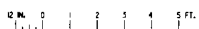
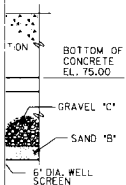

DETAIL

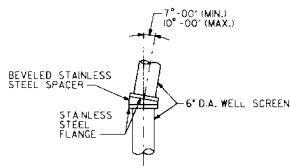

NOTE.
FOR SECTION D2-D2 SEE PLATE 21
FOR SECTION E-E SEE PLATE 22

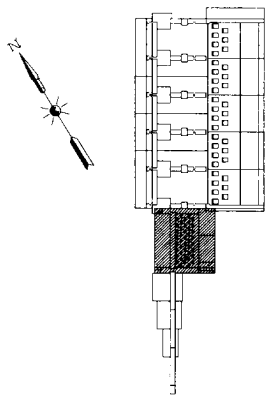

KEY PLAN

ILET PIPE



RED RIVER WATERWAY-MISSISSIPPI RIVER TO SHREVEPORT, L.A.
U. S. ARMY ENGINEER DISTRICT, VICKSBURG
CORPS OF ENGINEERS
VICKSBURG, MISSISSIPPI

LOCK AND DAM NO. 4.

FOUNDATION REPORT

CREST GATED SPILLWAY

MONOLITH D-5

UNDERDRAIN SYSTEM

PLANS, SECTIONS AND DETAILS

DATE: JANUARY 1936

FILE NO. R-14-206

PLATE 20

3

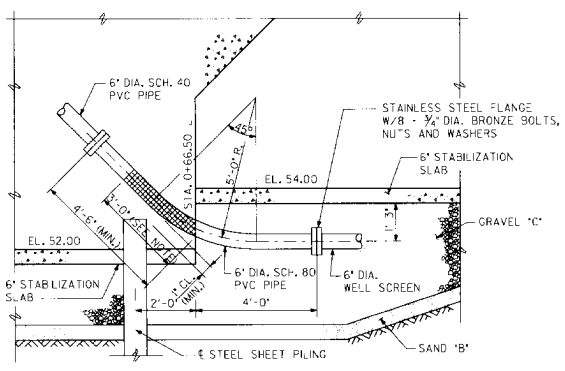
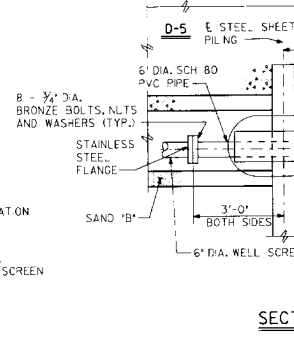
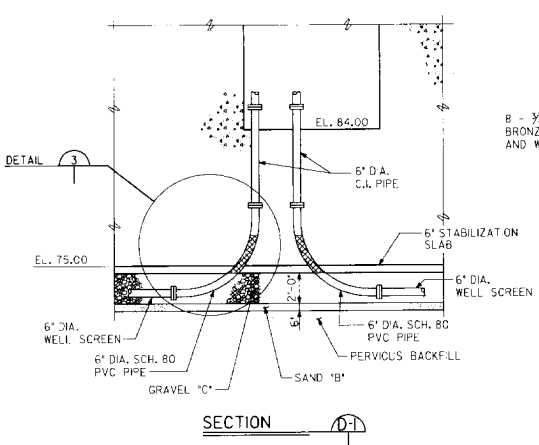
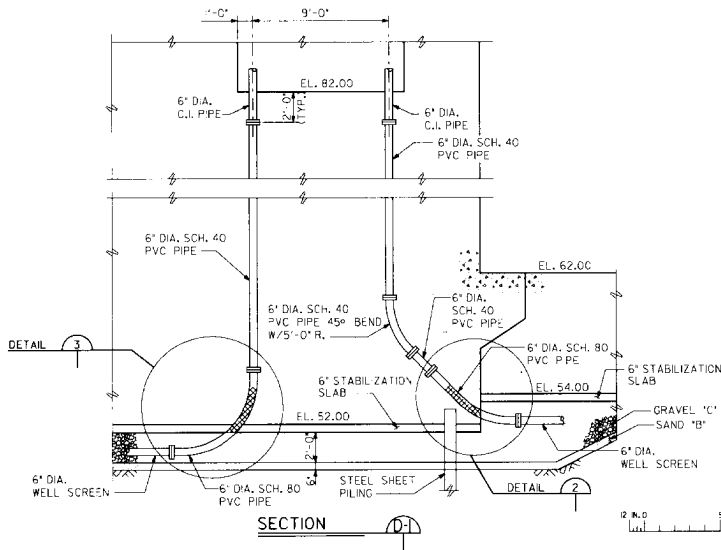

NOTE:
WRAP PVC PIPE WITH 1" PREFORMED JOINT FILLER AND WITH TAPE.

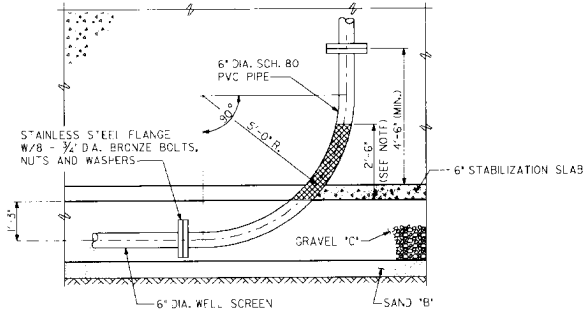

NOTE:
WRAP PVC PIPE WITH 1" PREFORMED JOINT FILLER AND WRAP JOINT FILLER WITH TAPE.

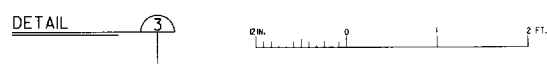
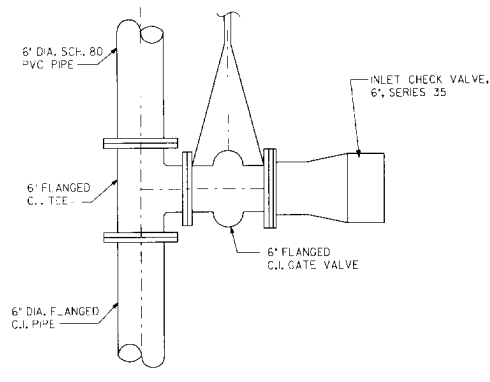
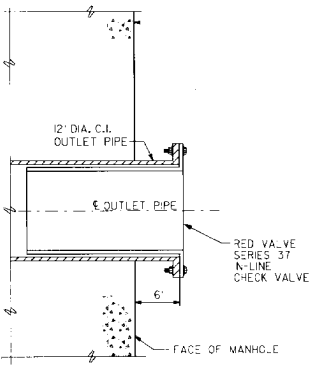

DETAIL 2

14002743D

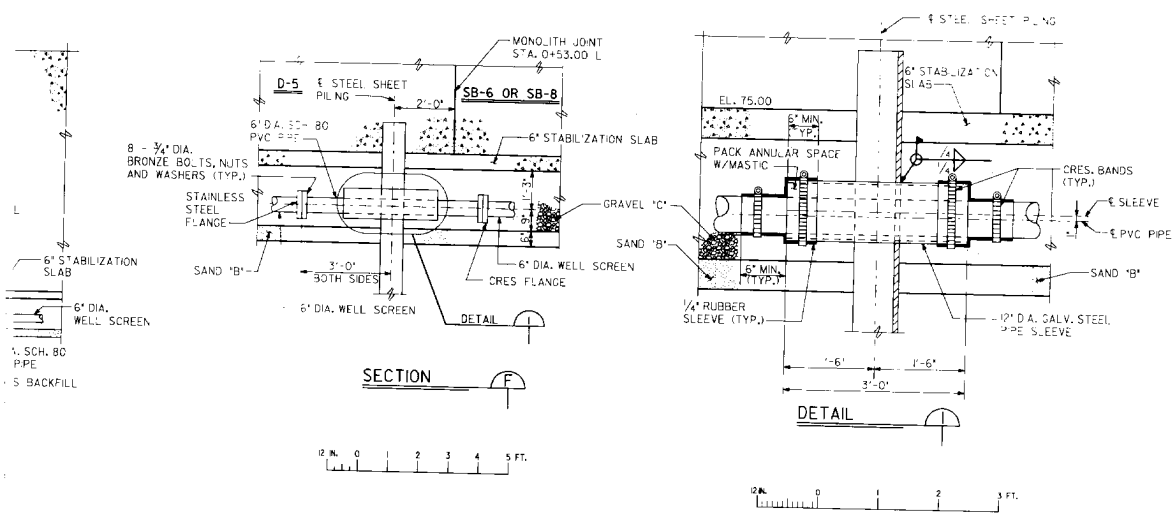

- NOTES:
1. WHERE CRES. PLATES OR FLANGES BOLT TO CAST IRON, DRILL HOLES IN FLANGE OR PLATE AND DIELECTRIC GASKET FOR 7/8" CRES. BOLTS, NUTS AND WASHERS W/DIELECTRIC PLASTIC BOLT SLEEVES AND FLAT WASHERS.
 2. THE MACHINED SURFACE OF STAINLESS STEEL PIPE SHALL BE SQUARE AND HORIZONTAL IN ALL DIRECTIONS PRIOR TO ACCEPTANCE BY THE CONTRACTING OFFICER.
 3. FOR LOCATION OF SECTION D-1 SEE PLATE 19
 4. FOR LOCATION OF SECTION D-2 SEE PLATE 20

INLET CHECK VALVE,
6" SERIES 35

RED RIVER WATERWAY-MISSISSIPPI RIVER TR
U. S. ARMY ENGINEER DISTRICT, VICK
CORPS OF ENGINEERS
VICKSBURG, MISSISSIPPI

LOCK AND DAM
FOUNDATION REPORT

**MONOLITHS D-1 WITH
UNDERDRAIN SYSTEM
SECTIONS AND DET.**

DATE: JANUARY 1996 FILE NO. R-14-2

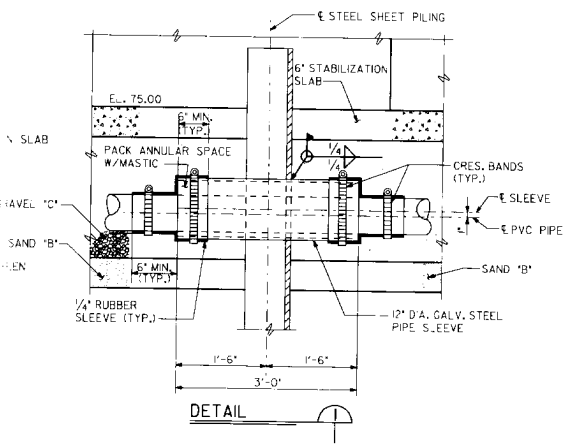

FR FLANGES BOLT TO CAST IRON, DRILL
 PLATE AND DIELECTRIC GASKET FOR
 AND WASHERS W/DIELECTRIC PLASTIC
 AT WASHERS.
 OF STAINLESS STEEL PIPE SHALL
 ONTAL IN ALL DIRECTIONS PRIOR TO
 CONTRACTING OFFICER.
 ON D-1 SEE PLATE 19
 ON D-2 SEE PLATE 20

RED RIVER WATERWAY-MISSISSIPPI RIVER TO SHREVEPORT, L.A.
 U. S. ARMY ENGINEER DISTRICT, VICKSBURG
 CORPS OF ENGINEERS
 VICKSBURG, MISSISSIPPI

LOCK AND DAM NO. 4
 FOUNDATION REPORT

MONOLITHS D-1 THRU D-5
 UNDERDRAIN SYSTEM
 SECTIONS AND DETAILS

DATE: JANUARY 1996 FILE NO. R-4-206 PLATE 21

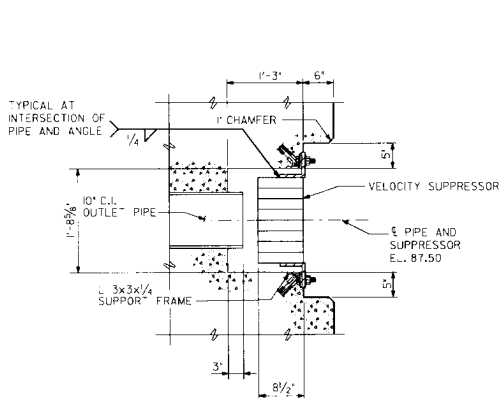

SECTIONAL ELEVATION

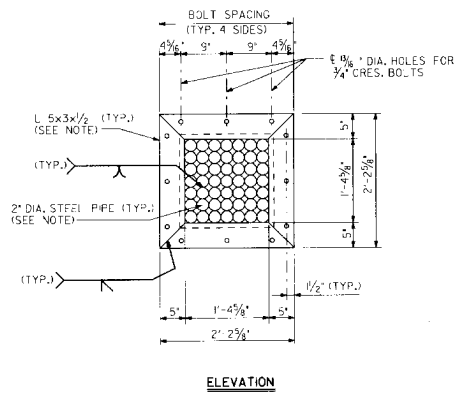
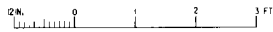

ELEVATION

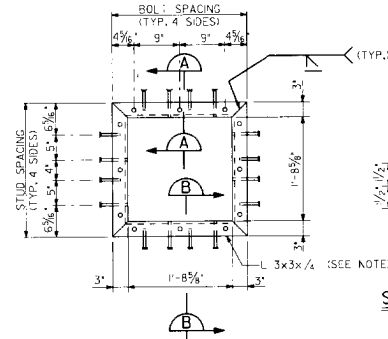

ELEVATION - SUPPORT FRAME

VELOCITY SUPPRESSOR

NOTE:
GALVANIZE VELOCITY SUPPRESSOR
AND SUPPORT FRAME AFTER WELDING.

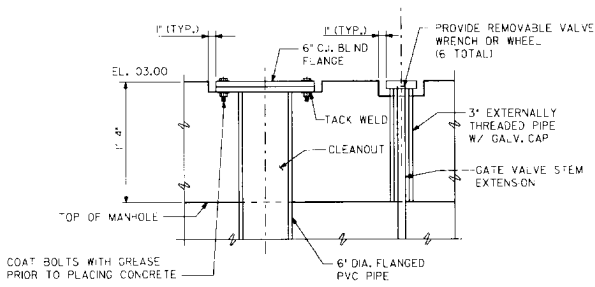

DETAIL 4

NOTE:
STAMP 6" C.I. BLIND FLANGE "DAM INFLOW"
OR "BASIN INFLOW" AS APPLICABLE

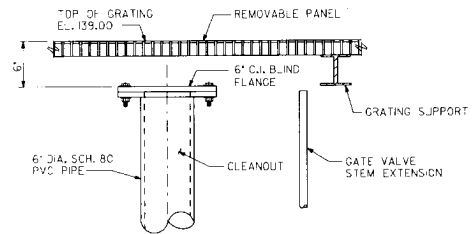
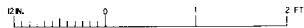

DETAIL 4

NOTE:
PROVIDE REMOVABLE VALVE WRENCH OR WHEEL (2 TO ALL)
STAMP 6" C.I. BLIND FLANGE "DAM INFLOW" OR "BASIN INFLOW"
AS APPLICABLE. PROVIDE PERMANENT IDENTIFICATION TAGS ON
GATE VALVE EXTENSIONS.

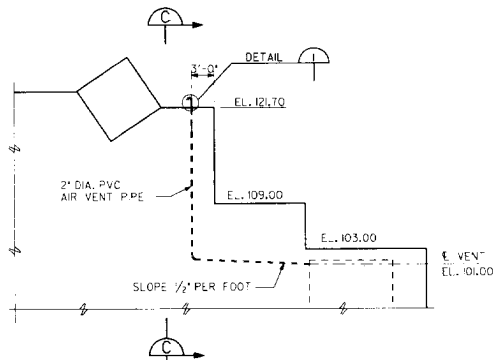

MANHOLE AIR VENT

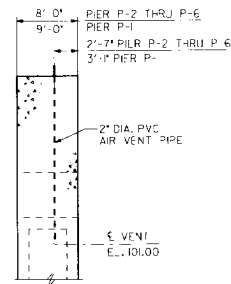

SECTION C

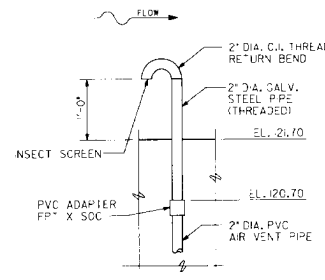

DETAIL 1

5 FOR 5

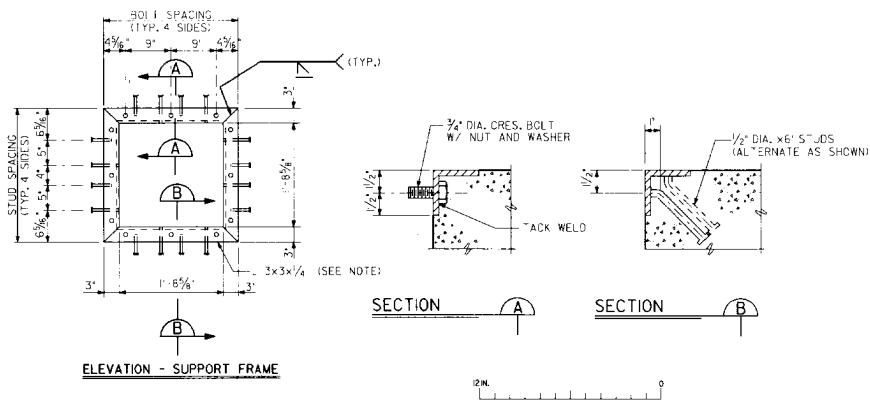

CITY SUPPRESSOR

1/2 VELOCITY SUPPRESSOR
SUPPORT FRAME AFTER WELDING.

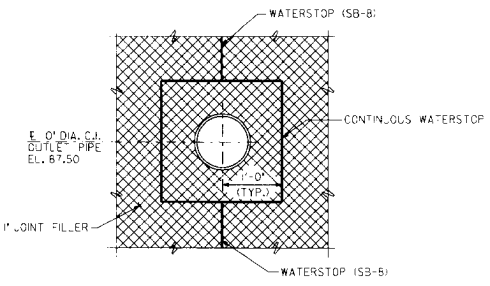
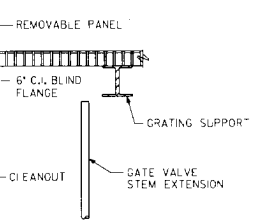

SECTION E

ALL VALVE WRENCH OR WHEEL (2 TOTAL)
NO FLANGE 'DAM INFLOW' OR 'BASIN INFLOW'
PROVIDE PERMANENT IDENTIFICATION TAGS ON
DIMENSIONS.

41 P-6
2 THRU P-6

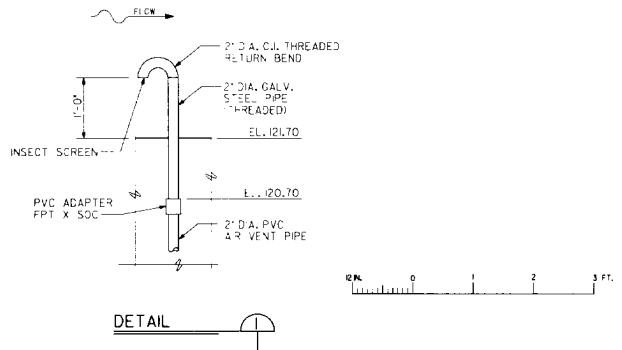

RED RIVER WATERWAY-MISSISSIPPI
U. S. ARMY ENGINEER DISTRICT
CORPS OF ENGINEERS
VICKSBURG, MISSISSIPPI

LOCK AND DAM FOUNDATION

MONOLITHS D

UNDERDRAIN SECTIONS AND

DATE: JANUARY 1996 FILE

2

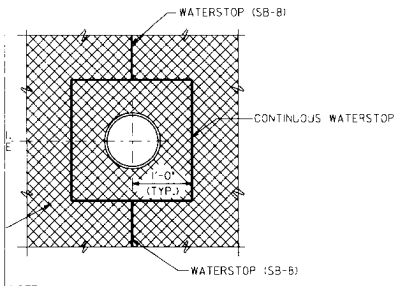
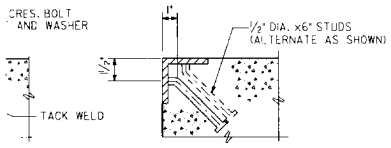

NOTE:
 1. OUTLET PIPE SHALL BE DISCONTINUOUS AT MONOLITH JOINT. PROVIDE 1" GAP TO MATCH JOINT FILLER MATERIAL. PROTECT ENDS OF PIPE DURING CONCRETE PLACEMENT.
 2. FOR LOCATION OF SECTION E SEE PLATE 19 AND 20

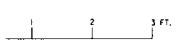
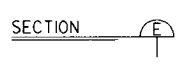

RED RIVER WATERWAY-MISSISSIPPI RIVER TO SHREVEPORT, LA.
 U. S. ARMY ENGINEER DISTRICT, VICKSBURG
 CORPS OF ENGINEERS
 VICKSBURG, MISSISSIPPI

LOCK AND DAM NO. 4

FOUNDATION REPORT

MONOLITHS D-1 THRU D-5

UNDERDRAIN SYSTEM

SECTIONS AND DETAILS

DATE: JANUARY 1996 FILE NO. R-14-206 PLATE 22

3

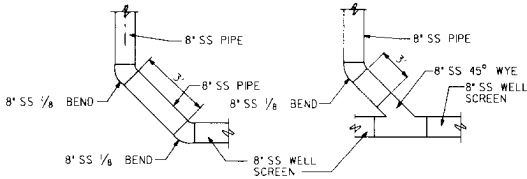
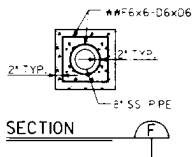
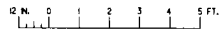
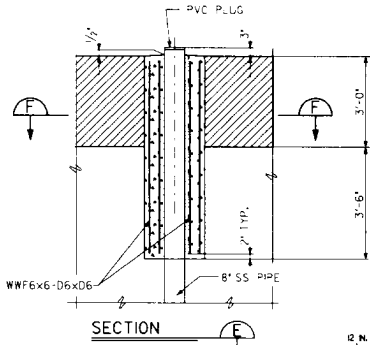
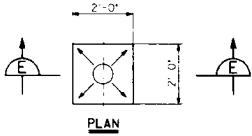

CLEANOUT PIPE DETAILS

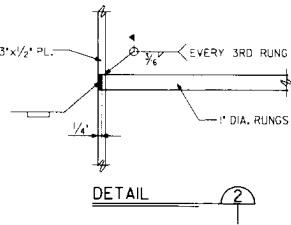
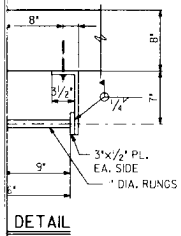

SS
VERT. EL.
121.0
99.44
99.40
98.56
97.75
96.93
112.0

VERT. EL.
11 OUTLET
110.99.9
110.96.0

RED RIVER WATERWAY-MISSISSIPPI RIVER TO SHREVEPORT, LA.
U. S. ARMY ENGINEER DISTRICT, VICKSBURG
CORPS OF ENGINEERS
VICKSBURG, MISSISSIPPI

LOCK AND DAM NO. 4

FOUNDATION REPORT

LOCK COLLECTOR DRAINAGE MANHOLES AND DETAILS

DATE: JANUARY 1996

FILE NO. R-14-206

PLATE 23

3

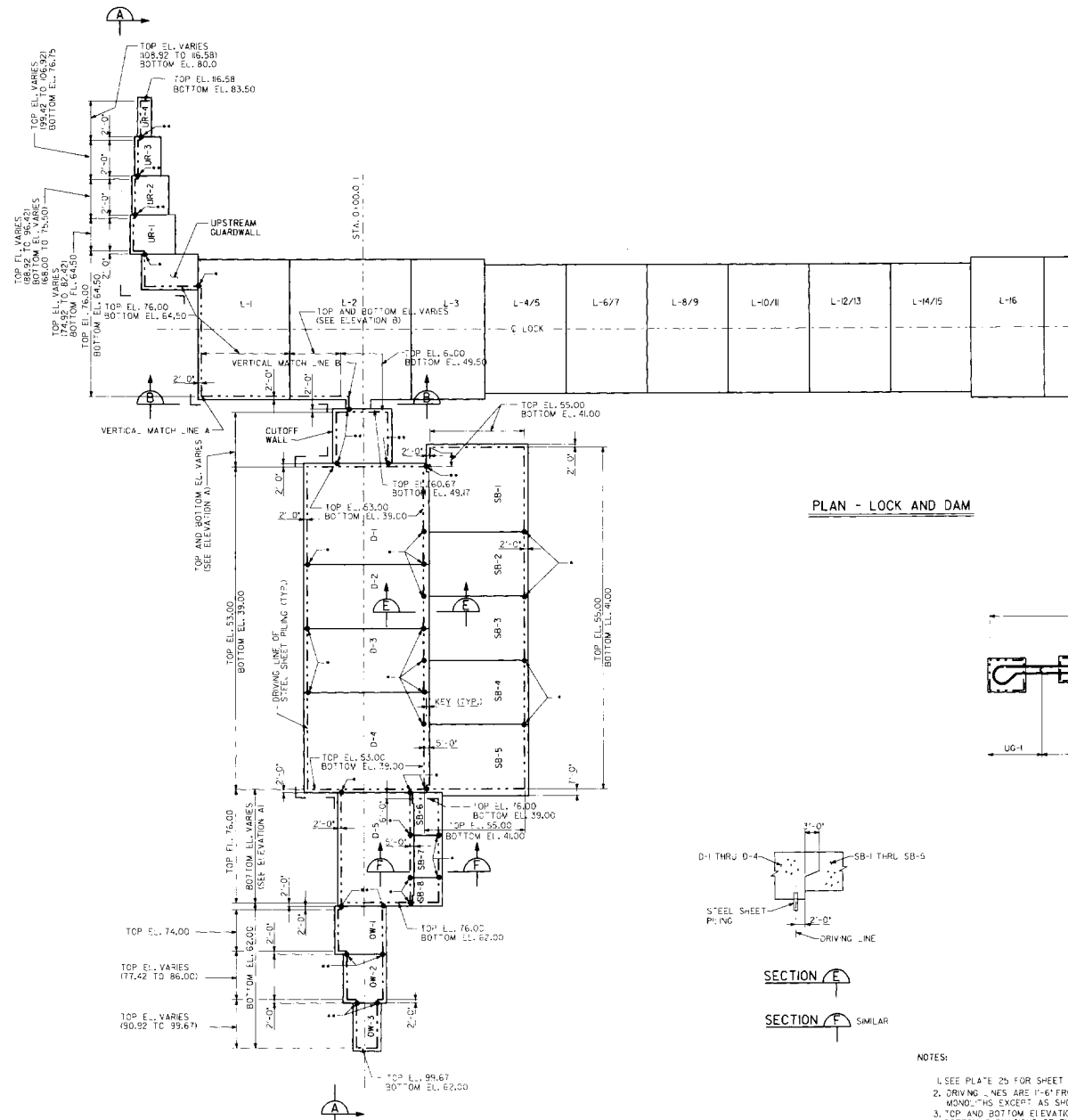

PLAN - LOCK AND DAM

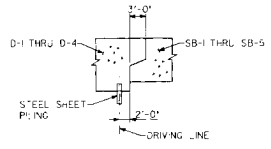

- NOTES:
1. SEE PLATE 25 FOR SHEET F
 2. DRIVING LINES ARE 1'-6" FROM MONUMENTS EXCEPT AS SHOWN
 3. TOP AND BOTTOM ELEVATION BOTTOM ELEVATIONS OF THE
 4. * INDICATES LOCATION OF SHEET PILING JOINTS BE INDICATED THUS:
 - TYPE A OR B CONNE
 - TYPE C OR D CONNE

3/10/2010

1

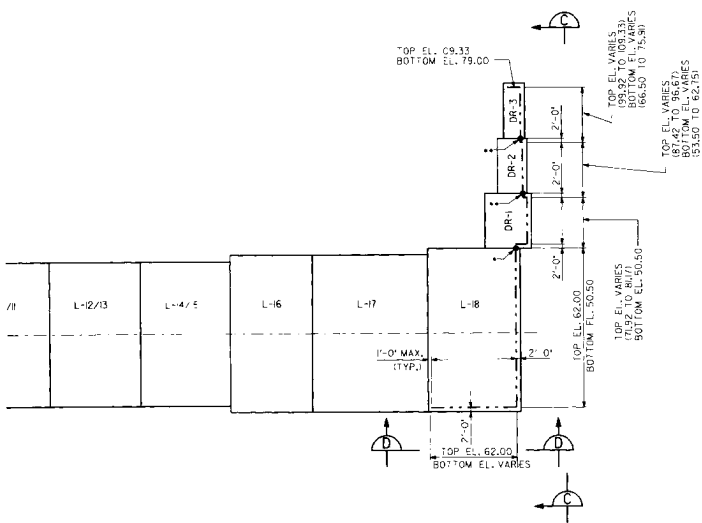

PLAN - LOCK AND DAM

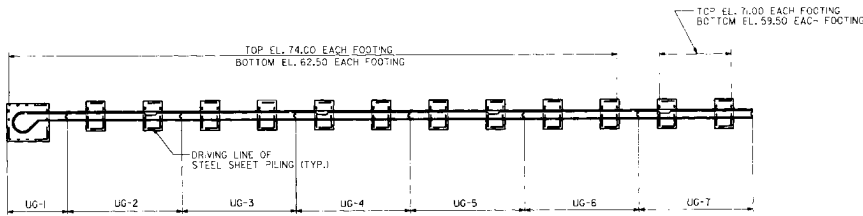

PLAN - UPSTREAM GUIDEWALL

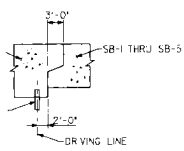

SECTION E

SECTION F SIMILAR

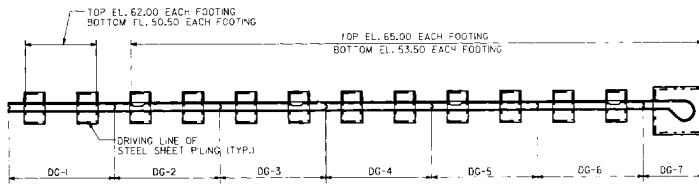

PLAN - DOWNSTREAM GUIDEWALL

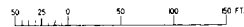

NOTES:

1. SEE PLATE 25 FOR SHEET PILING SECTIONS AND NOTES
2. DRAWING LINES ARE 1'-6" FROM FACE OF CONCRETE BASE OF MONOLITHS EXCEPT AS SHOWN.
3. TOP AND BOTTOM ELEVATIONS REFER TO THE TOP AND BOTTOM ELEVATIONS OF THE SHEET PILING.
4. ● INDICATES LOCATION OF WATERSTOP CONNECTIONS TO SHEET PILING AT JOINTS BETWEEN MONOLITHS WITH TYPE INDICATED THEREAS:
 - TYPE A OR B CONNECTION.
 - TYPE C OR D CONNECTION.

RED RIVER WATERWAY-MISSISSIPPI RIVER TO SI
 U. S. ARMY ENGINEER DISTRICT, VICKSBURG
 CORPS OF ENGINEERS
 VICKSBURG, MISSISSIPPI

LOCK AND DAM I
 FOUNDATION REPORT
 SHEET PILING LA

DATE: JANUARY 1996

FILE NO. R-14-206

2

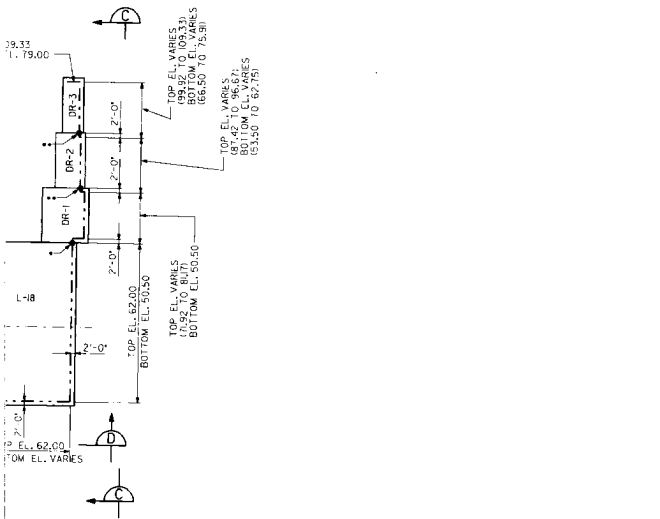

PLAN - UPSTREAM GUIDEWALL

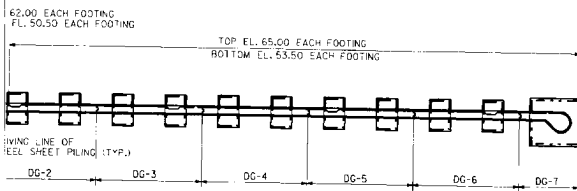

PLAN - DOWNSTREAM GUIDEWALL

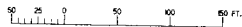

TFS
BASE OF
AND
TO
TYPE

RED RIVER WATERWAY-MISSISSIPPI RIVER TO SHREVEPORT, I.A.
U. S. ARMY ENGINEER DISTRICT, VICKSBURG
CORPS OF ENGINEERS
VICKSBURG, MISSISSIPPI

LOCK AND DAM NO. 4
FOUNDATION REPORT
SHEET PILING LAYOUT

DATE: JANUARY 1996

FILE NO. R-14-206

PLATE 24

3

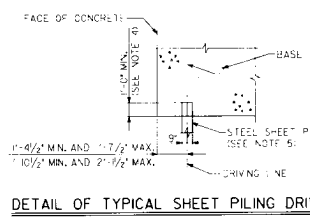
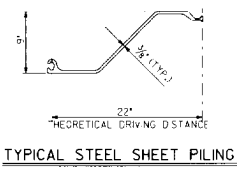
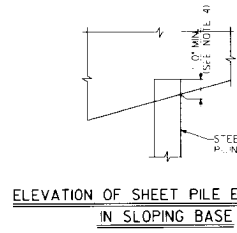
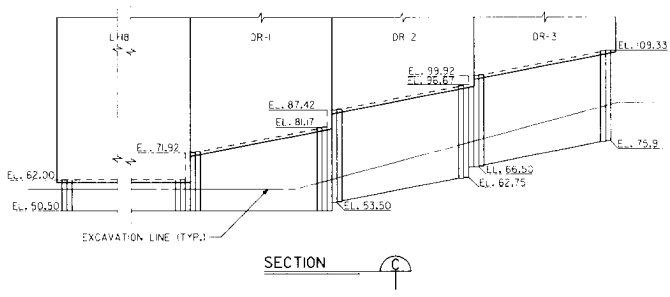
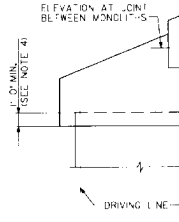
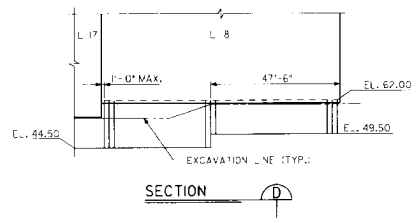
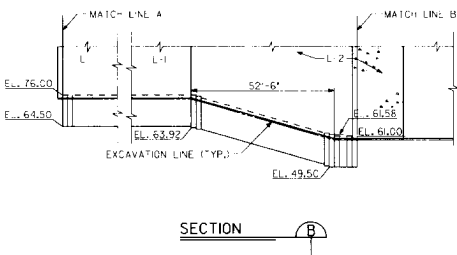
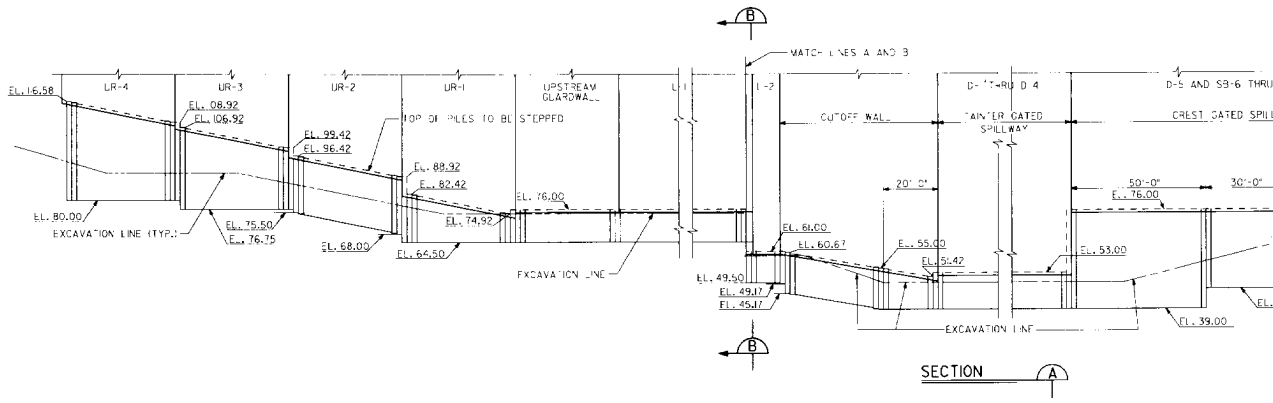

1

2

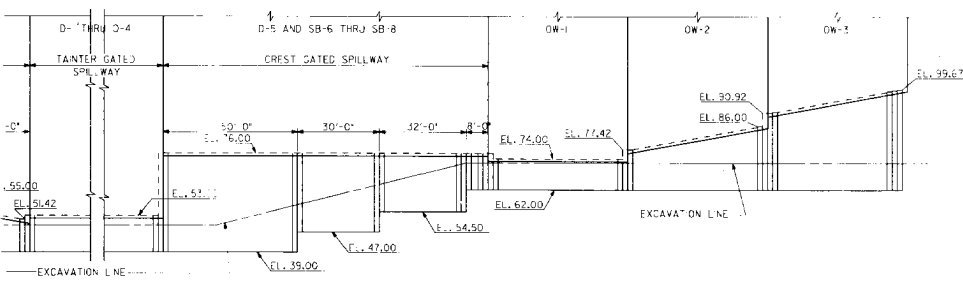

SECTION A

EL. 62.00
EL. 50

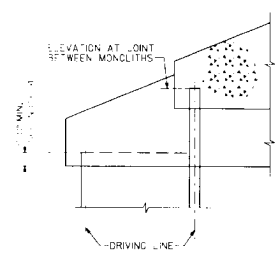

ELEVATION OF SHEET PILING AT ENDS OF MONOLITHS

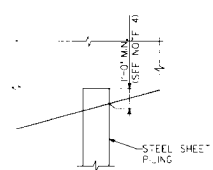

ELEVATION OF SHEET PILE EMBEDMENT IN SLOPING BASE

- SHEET PILING NOTES:**
1. SHEET PILING SHALL BE INSTALLED WITHIN THE LIMITS SHOWN ON THIS DRAWING.
 2. ALL SHEET PILING SHALL BE P772 EXCEPT AS NOTED.
 3. ALL FABRICATED TEES, CROSSES, BENDS AND SPECIAL SHEET PILING SHALL BE FABRICATED FROM P772 SHEET PILING AND ANGLES 3/8"x3/8" OR 3/8" x 3/8" WITH 1/8" DIA. A325 HIGH-STRENGTH BOLTS SPACED 3XON CENTERS. 90 DEGREE CORNER SECTIONS MADE FROM PS423 PILING IS PERMITTED.
 4. THE TOP OF EACH SHEET PILE SHALL BE EMBEDDED A MIN. OF 1'-2" TO 1'-2 1/2" MAX. INTO THE CONCRETE BASE.
 5. THE DRIVING LINE OF THE SHEET PILE SHALL BE 1/8" (2.5) OR 2'-0" (61.5) FROM THE FACE OF THE CONCRETE BASE. SEE DETAIL.
 6. THE 6" OF THE INTERLOCK OF SHEET PILLS AT THE JOINTS BETWEEN MONOLITHS WITH WATERS OF CONNECTIONS SHALL BE WITHIN 3" EITHER SIDE OF THE JOINT. THE TOP OF SHEET PILE EACH SIDE OF THE JOINT SHALL BE AT THE ELEVATION OF THE HIGHER.
 7. THE CONTRACTOR SHALL BE RESPONSIBLE FOR THE FINAL LAYOUT AND PLACEMENT THAT WILL MEET SPECIFIED TOLERANCES AND ALLOW CLOSURE OF THE SHEET PILING WALLS.
 8. HORIZONTAL SPLICES SHALL NOT BE PERMITTED ON ANY SHEET PILING WALL UNLESS APPROVED BY THE CONTRACTING OFFICER.
 9. THE SHEET PILING SHALL NOT BE CUT OR INTERRUPTED TO ACCOMMODATE CONCRETE FORMS OR OTHER CONSTRUCTION DEVICES, EXCEPT AS SHOWN OR NOTED ON THE DRAWINGS.
 10. FOR LOCATION OF SECTIONS SEE PLATE 24



DETAIL OF TYPICAL SHEET PILING DRIVING LINE

RED RIVER WATERWAY, MISSISSIPPI RIVER TO
 U. S. ARMY ENGINEER DISTRICT, VICKSBURG
 CORPS OF ENGINEERS
 VICKSBURG, MISSISSIPPI

LOCK AND DAM NO. 1
FOUNDATION REPORT
LOCK AND DAM
SHEET PILING SECTION

DATE: JANUARY 1996 FILE NO. R-4-206

2

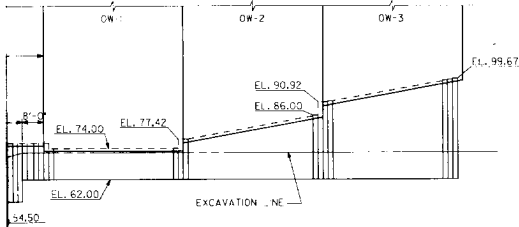

SHEET PILING NOTES:

1. SHEET PILING SHALL BE INSTALLED WITHIN THE LIMITS SHOWN ON THIS DRAWING.
2. ALL SHEET PILING SHALL BE P222 EXCEPT AS NOTED.
3. ALL FABRICATED TEES, CROSSES, BENDS AND SPECIAL SHEET PILING SHALL BE FABRICATED FROM P222 SHEET PILING AND ANGLES 3/2x3/2x3/8 OR 3/4" R WITH 3/4" DIA. A325 HIGH STRENGTH BOLTS SPACED 3" ON CENTERS. 90-DEGREE CORNER SECTIONS MADE FROM PSA23 PILING IS PERMITTED.
4. THE TOP OF EACH SHEET PILE SHALL BE EMBEDDED A MIN. OF 1'-0" TO 1'-2" MAX. INTO THE CONCRETE BASE.
5. THE DRIVING LINE OF THE SHEET PILE SHALL BE 1'-6" (±.5") OR 2'-0" (±1.5") FROM THE FACE OF THE CONCRETE BASE. SEE DETAIL.
6. THE E OF THE INTERLOCK OF SHEET PILES AT THE JOINTS BETWEEN MONOLITHS WITH WATERSTOP CONNECTIONS SHALL BE WITHIN 3" EITHER SIDE OF THE JOINT. THE TOP OF SHEET PILE EACH SIDE OF THE JOINT SHALL BE AT THE ELEVATION OF THE HIGH-ER.
7. THE CONTRACTOR SHALL BE RESPONSIBLE FOR THE FINAL ADJUST AND PLACEMENT THAT WILL MEET SPECIFIED TOLERANCES AND ALLOW CLOSURE OF THE SHEET PILING WALLS.
8. HORIZONTAL SPLICES SHALL NOT BE PERMITTED ON ANY SHEET PILING WALL UNLESS APPROVED BY THE CONTRACTING OFFICER.
9. THE SHEET PILING SHALL NOT BE CUT OR INTERRUPTED TO ACCOMMODATE CONCRETE FORMS OR OTHER CONSTRUCTION DEVICES, EXCEPT AS SHOWN OR NOTED ON THE DRAWINGS.
10. FOR LOCATION OF SECTIONS SEE PLATE 24

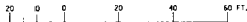

RED RIVER WATERWAY MISSISSIPPI RIVER TO SHREVEPORT, LA.
 U. S. ARMY ENGINEER DISTRICT, VICKSBURG
 CORPS OF ENGINEERS
 VICKSBURG, MISSISSIPPI

LOCK AND DAM NO. 4
 FOUNDATION REPORT
 LOCK AND DAM
 SHEET PILING SECTIONS

DATE: JANUARY 1996

FILE NO. R-14-206

PLATE 25

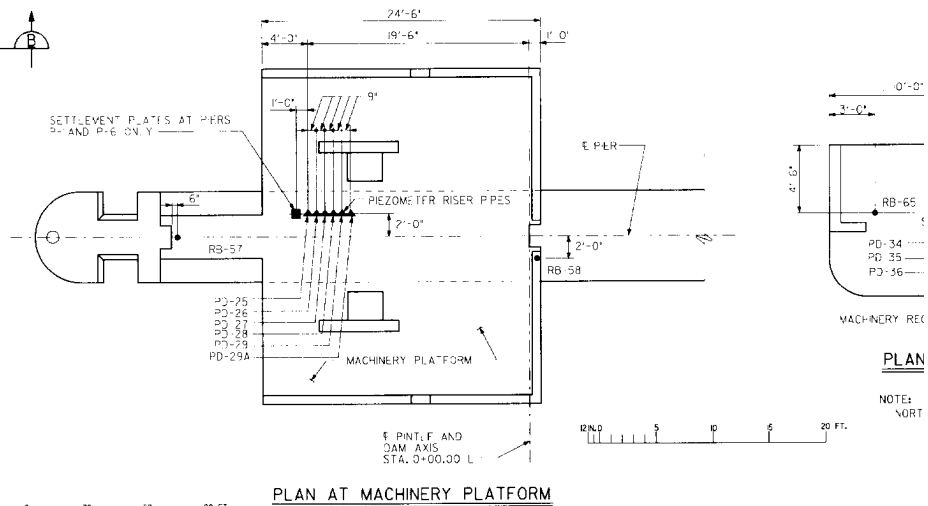
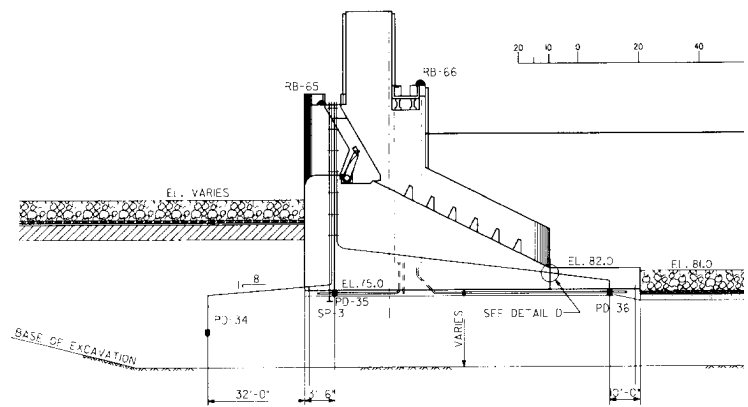
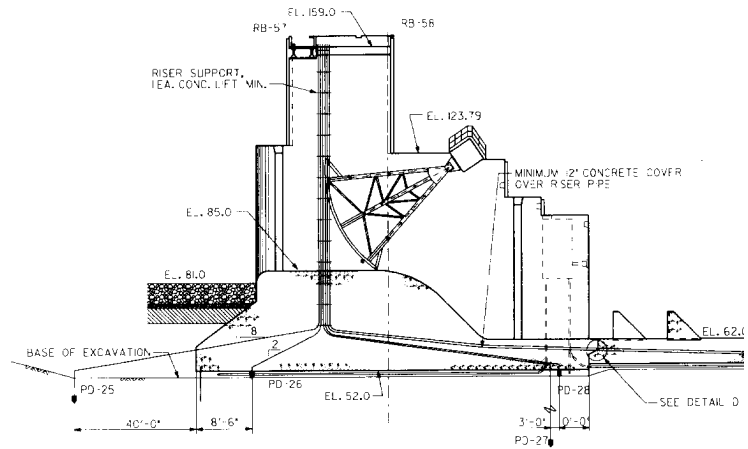
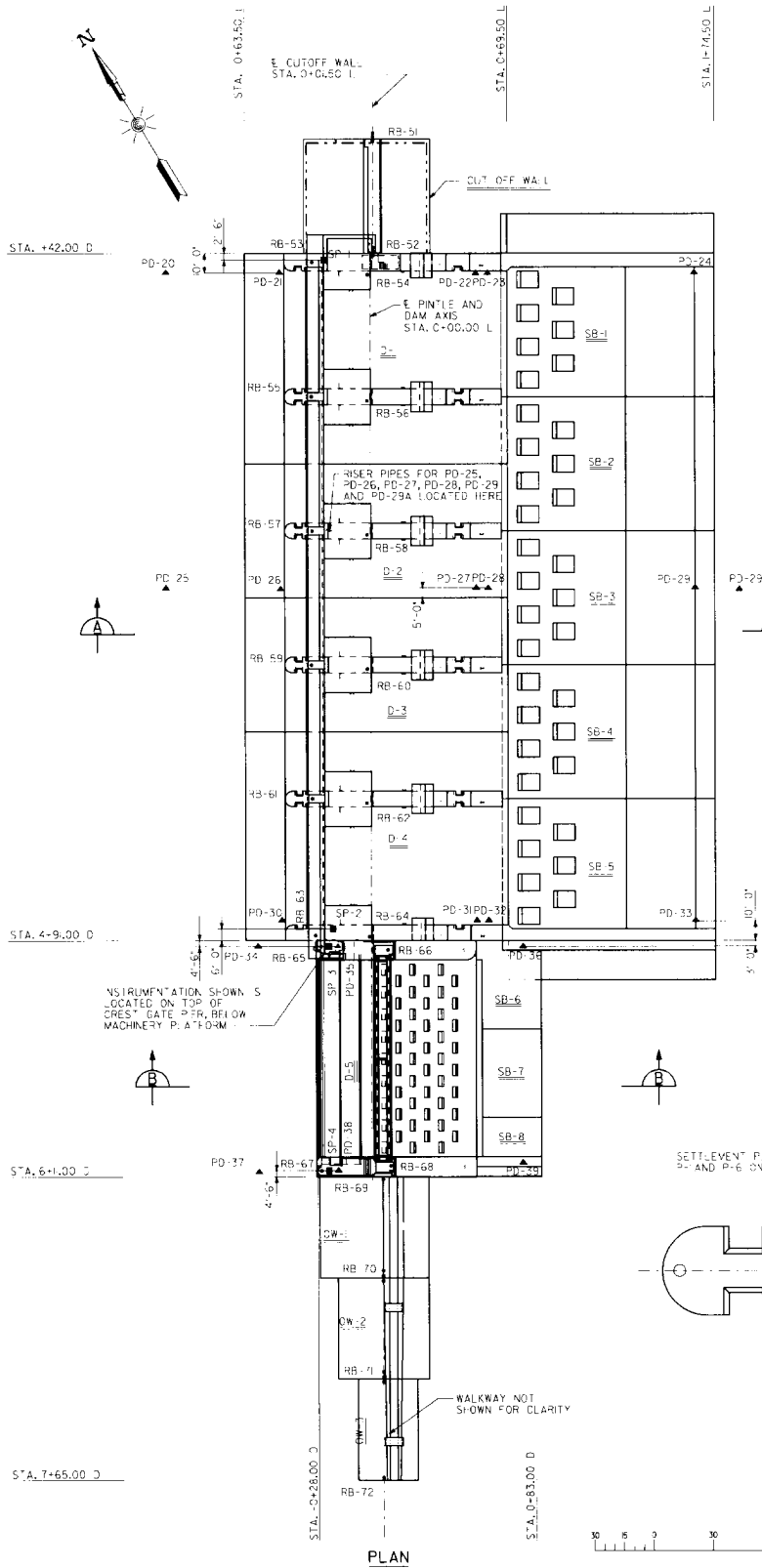

NOTE: INTERMEDIATE PIER P-3 SHOWN, AND PERS SIMILAR.

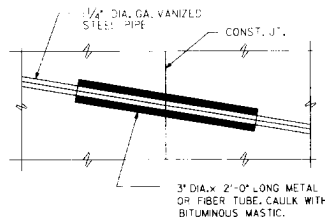
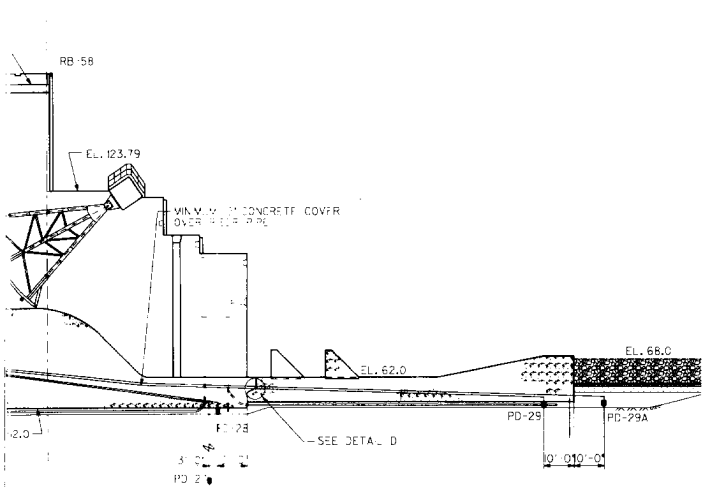

DETAIL D



SECTION A

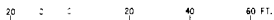

U BOLT WITH NUT FOR 2\"/>

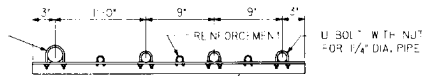

U BOLT WITH NUT FOR 1/4\"/>

RISER PIPE SPACER DETAIL

NOTE:
PIPE SPACER SHOWN FOR ILLUSTRATION.
THE NUMBER OF RISER PIPES AND THE
PRESENCE OF THE SETTLEMENT PLATE
VARIES WITH LOCATION. PIPE SPACERS
ARE REQUIRED FOR ALL RISERS IN LOCK
AND DAM STRUCTURE.

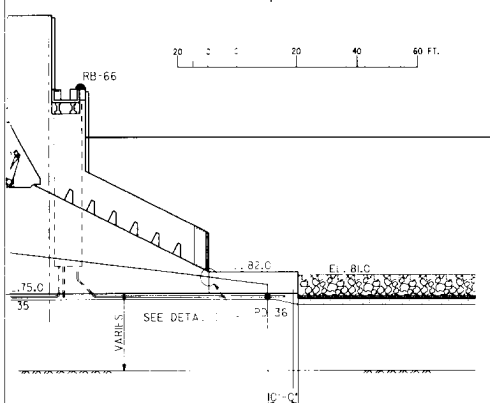

SECTION B

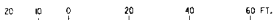

SYMBOL		INSTRUMENTS AND ABBREVIATIONS
SECTION	PLAN	
		PIEZOMETERS (PDI)
		REFERENCE BOLT GROUPS (RBI)
		SETTLEMENT PLATE (SP)

LEGEND

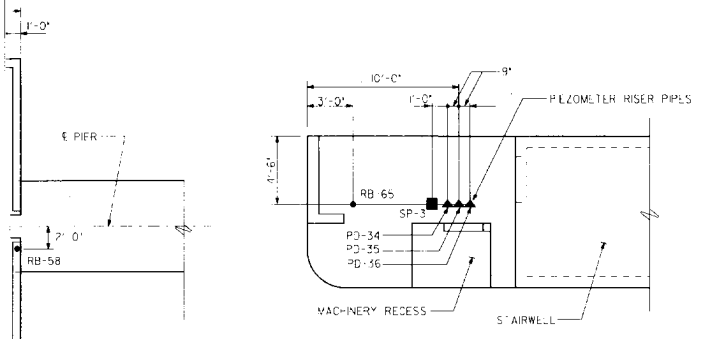

PLAN AT CREST GATE PIER

NOTE:
NORTH PIER SHOWN, SOUTH PIER SIMILAR.



RED RIVER WATERWAY-MISSISSIPPI RIVER TO S
U. S. ARMY ENGINEER DISTRICT, VICKSBURG
CORPS OF ENGINEERS
VICKSBURG, MISSISSIPPI

LOCK AND DAM N
FOUNDATION REPORT

TANTIER GATE & CRES
SPILLWAY INSTRUMENT

DATE: JANUARY 1996

FILE NO. R-14-20

2

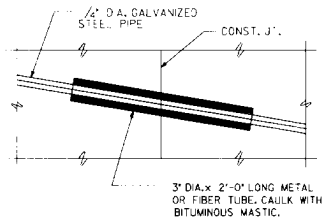

DETAIL D

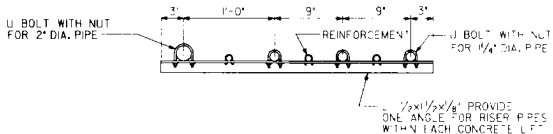
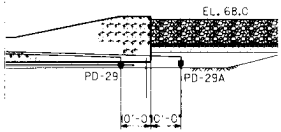

RISER PIPE SPACER DETAIL

NOTE:
PIPE SPACER SHOWN FOR ILLUSTRATION. THE NUMBER OF RISER PIPES AND THE PRESENCE OF THE SETTLEMENT PLATE VARIES WITH LOCATION. PIPE SPACERS ARE REQUIRED FOR ALL RISERS IN LOCK AND DAM STRUCTURE.

SYMBOL		INSTRUMENTS AND ABBREVIATIONS
SECTION	PLAN	
		PIEZOMETERS (PD)
		REFERENCE BOLT GROUPS (RBI)
		SETTLEMENT PLATE (SP)

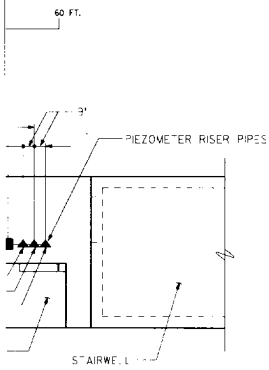

CREST GATE PIER



RED RIVER WATERWAY-MISSISSIPPI RIVER TO SHREVEPORT, LA.
U. S. ARMY ENGINEER DISTRICT, VICKSBURG
CORPS OF ENGINEERS
VICKSBURG, MISSISSIPPI

**LOCK AND DAM NO. 4
FOUNDATION REPORT**

**TANTIER GATE & CREST GATE
SPILLWAY INSTRUMENTATION**

DATE: JANUARY 1996 FILE NO. R-14-206 PLATE 26

3

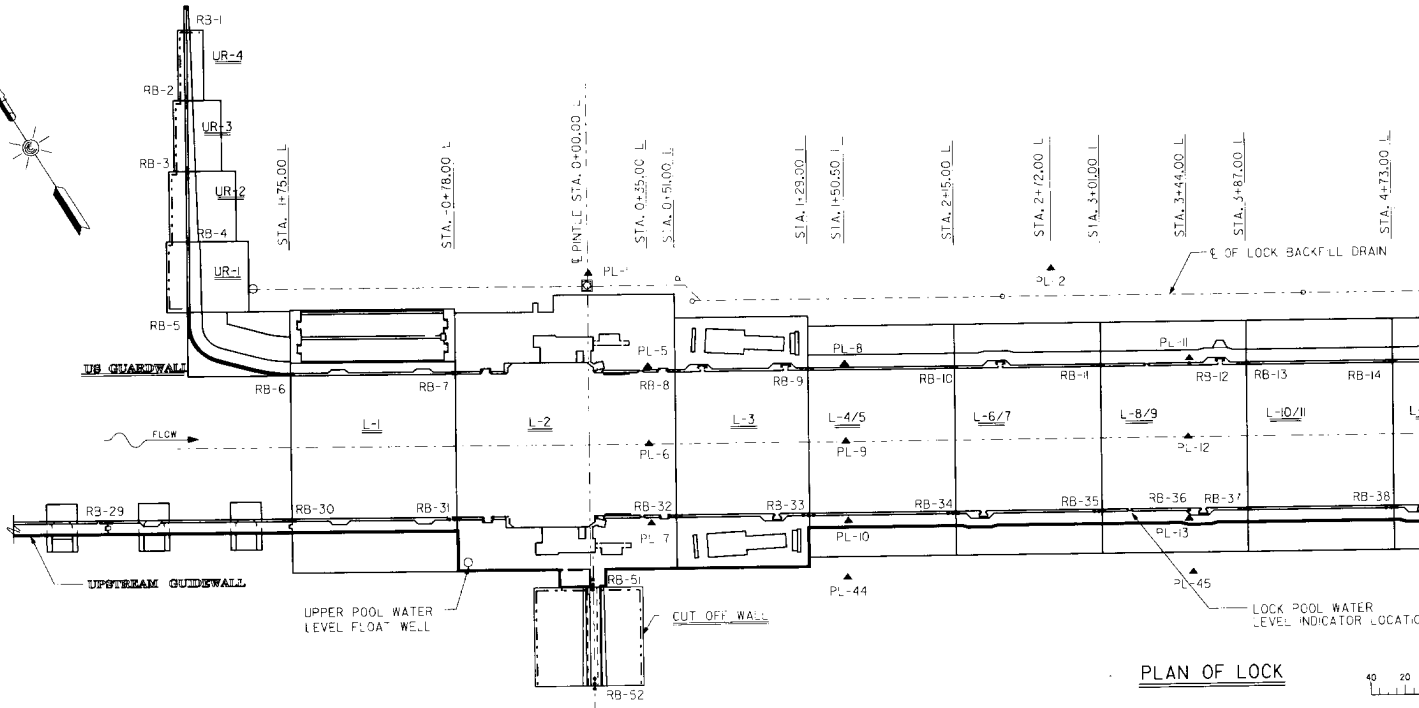
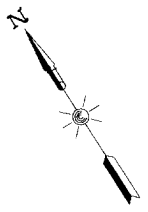

PLAN OF LOCK

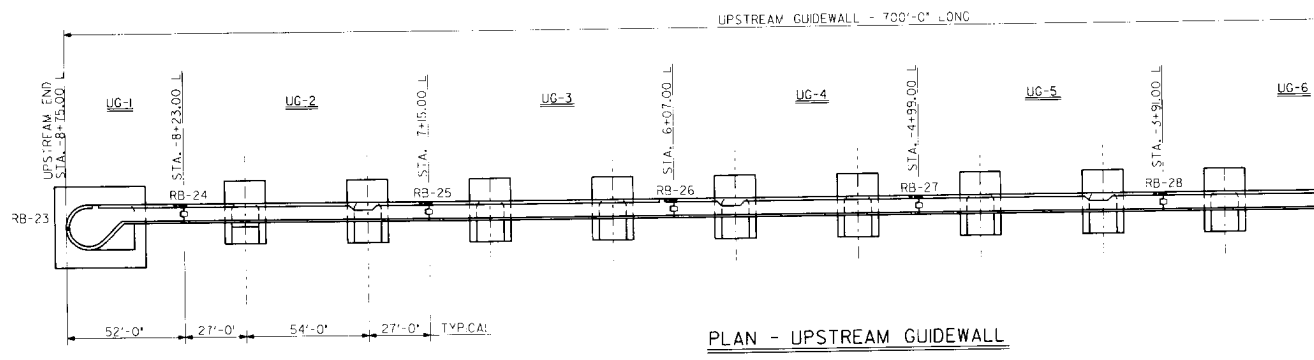

PLAN - UPSTREAM GUIDEWALL

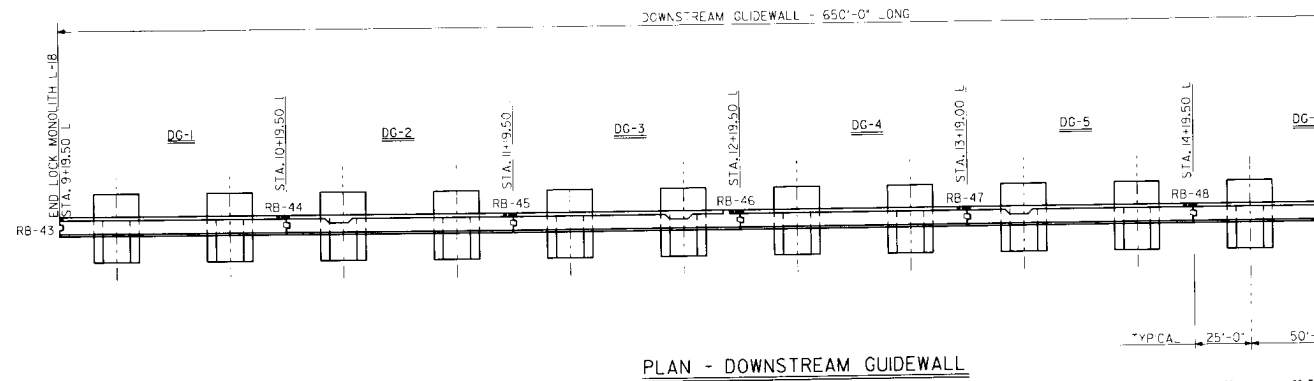

PLAN - DOWNSTREAM GUIDEWALL

UDCV246.30

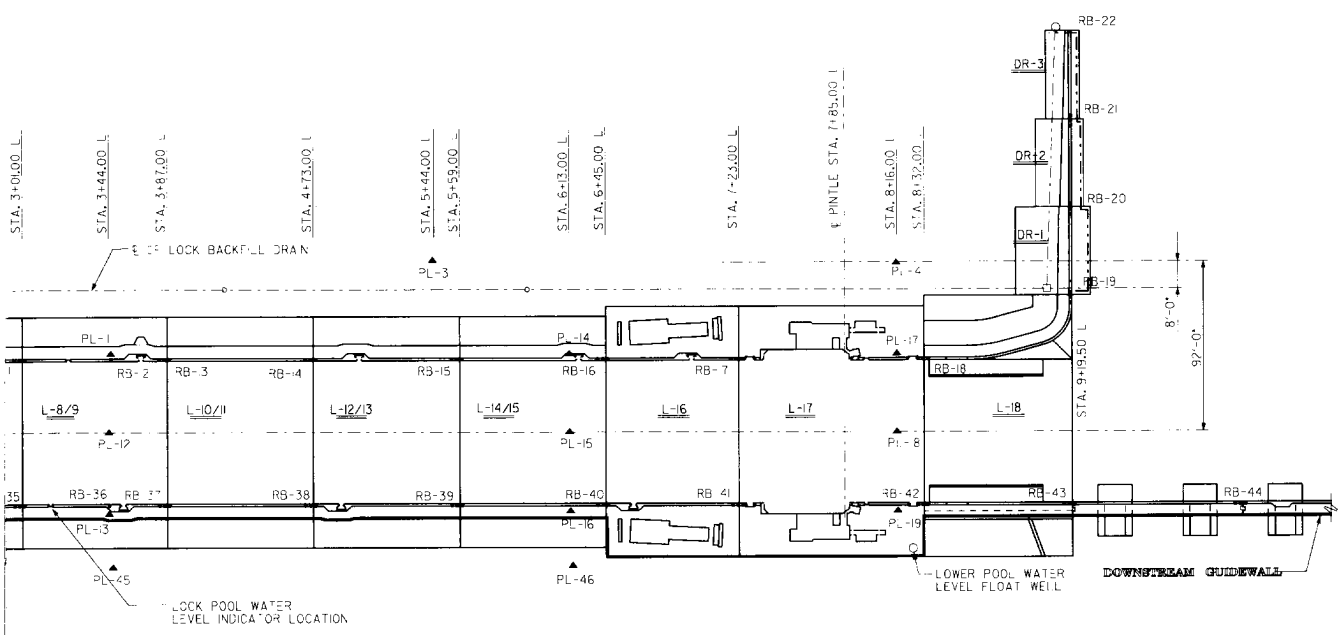

PLAN OF LOCK



SYMBOL		INSTRUMENTS AND ABBREVIATIONS
SECTION	PLAN	
		PIEZOMETERS (PL)
		REFERENCE BOLT GROUPS (RB)

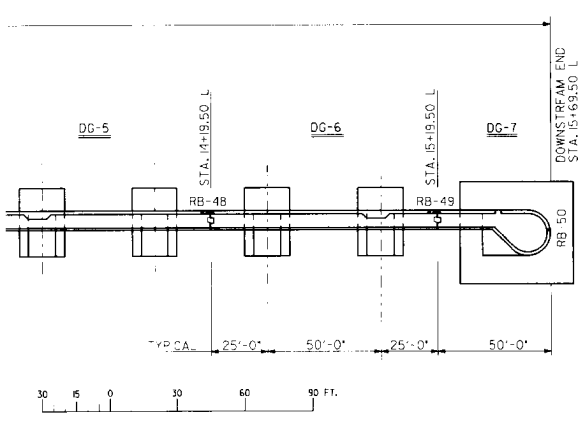
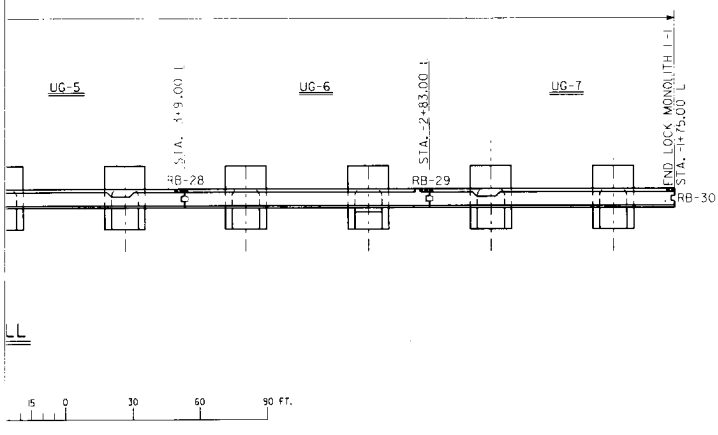

RED RIVER WATERWAY-MISSISSIPPI RIVER TO SHREVEPORT
 U. S. ARMY ENGINEER DISTRICT, VICKSBURG
 CORPS OF ENGINEERS
 VICKSBURG, MISSISSIPPI

LOCK AND DAM NO. 1

FOUNDATION REPORT

LOCK INSTRUMENTATION PLAN

DATE: JANUARY 1996 FILE NO. R-14-206

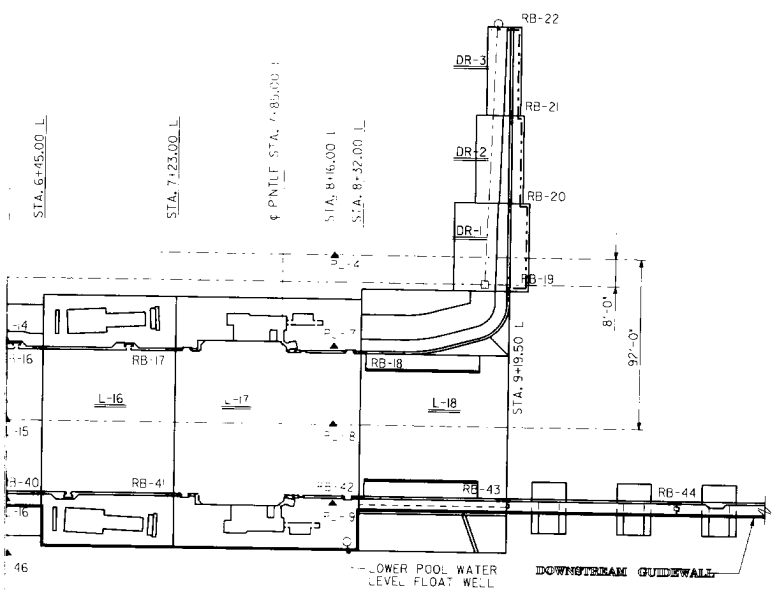

SYMBOL		INSTRUMENTS AND ABBREVIATIONS
SECTION	PLAN	
▲	▲	PIEZOMETERS (PI)
●	●	REFERENCE BOLT GROUPS (RB)

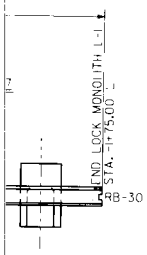

RED RIVER WATERWAY-MISSISSIPPI RIVER TO SHREVEPORT, LA.
 U. S. ARMY ENGINEER DISTRICT, VICKSBURG
 CORPS OF ENGINEERS
 VICKSBURG, MISSISSIPPI

LOCK AND DAM NO. 4
FOUNDATION REPORT

LOCK INSTRUMENTATION PLAN

 DATE: JANUARY 1996 FILE NO. R-14-206 PLATE 27

3

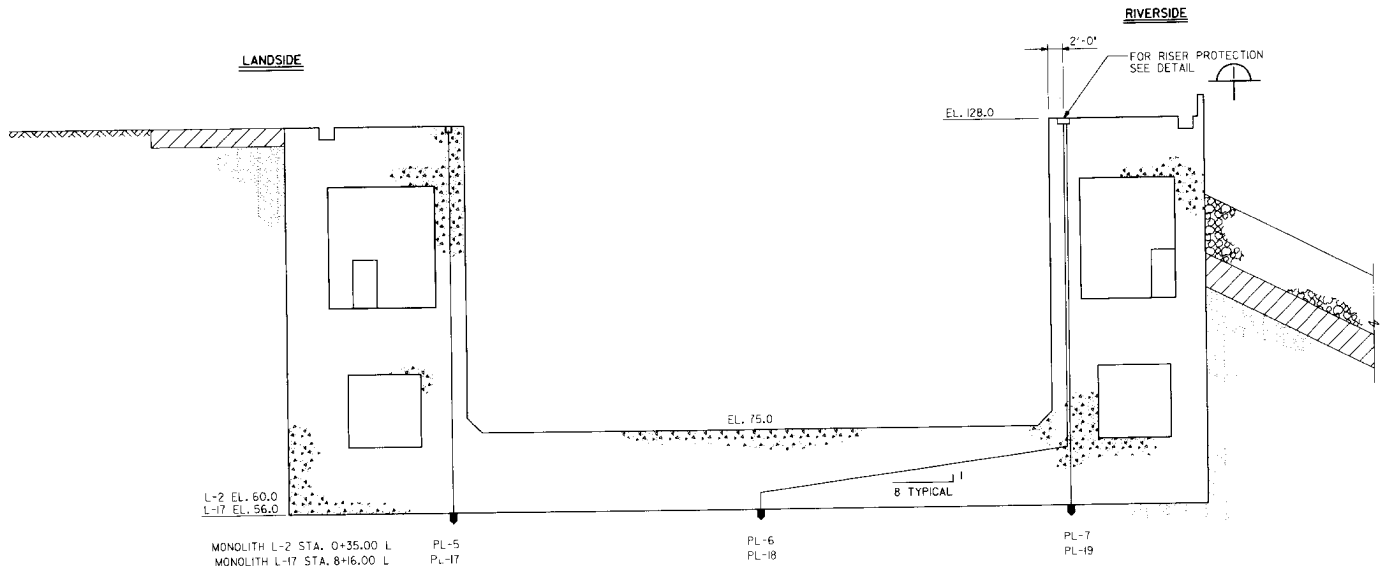

GATE MONOLITH PIEZOMETERS

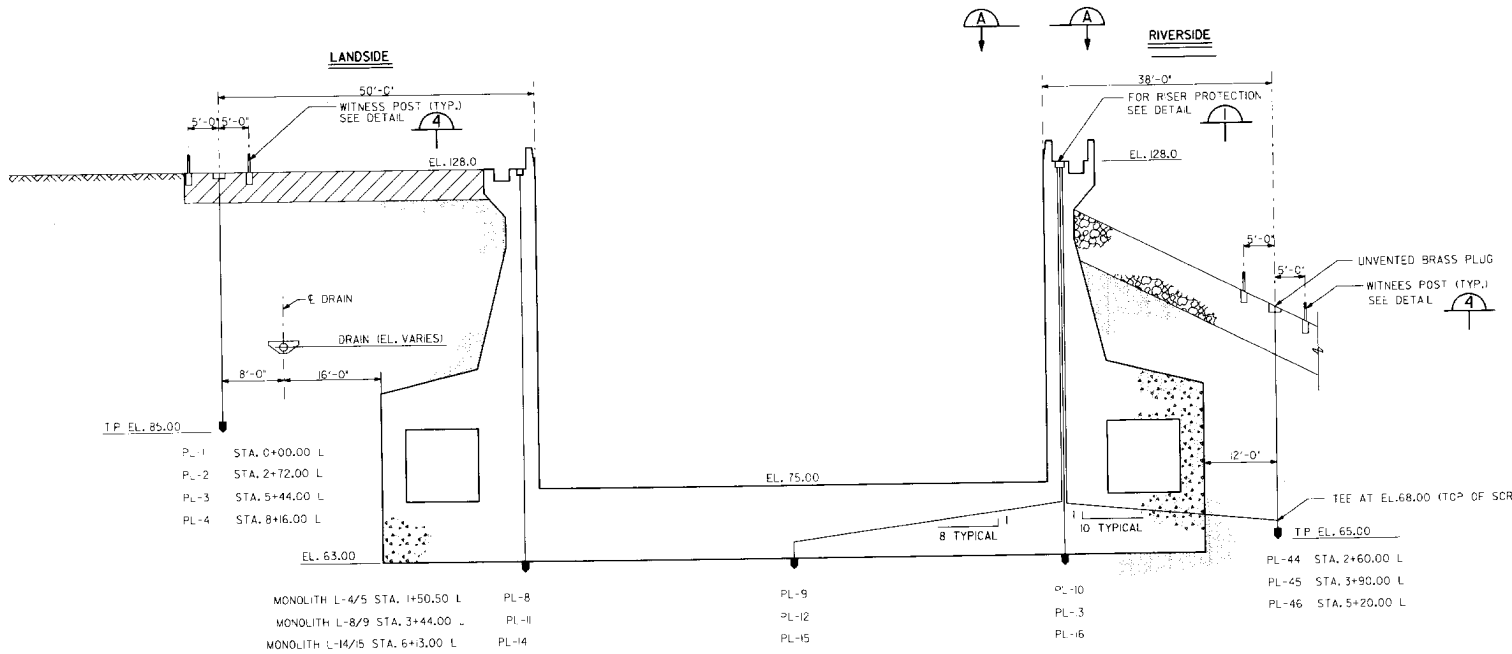

CHAMBER MONOLITH AND LOCK BACKFILL PIEZOMETERS

LOCK MONOLITH PIEZOMETERS



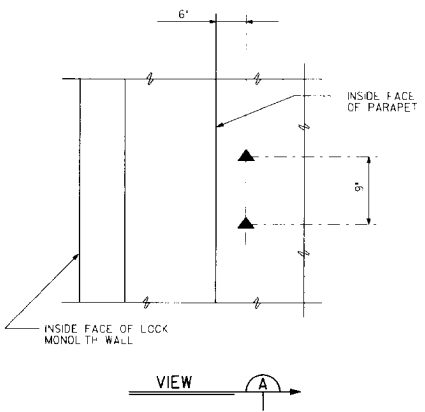
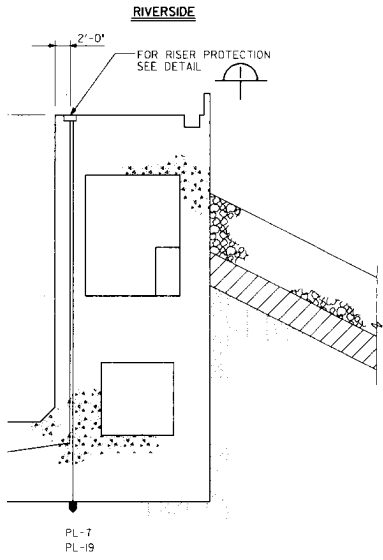

NOTE:
DETAIL SHOWN ON RIVERWALL SIDE OF
LOCK MONOLITH, DETAILS ON LANDWALL SIDE OF LOCK

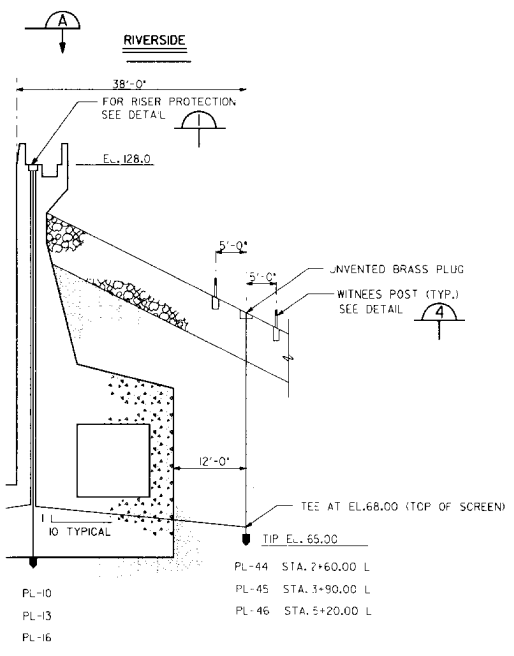

SYMBOL		INSTRUMENTS AND ABBREVIATIONS
SECTION	PLAN	
▼	▲	PIEZOMETERS (PL)

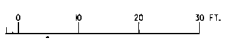

RED RIVER WATERWAY-MISSISSIPPI
U. S. ARMY ENGINEER DISTR
CORPS OF ENGINEERS
VICKSBURG, MISSISSIPPI

LOCK AND D
FOUNDATION
LOCK INSTRUM
SECTION

DATE: JANUARY 1996 FILE NO.

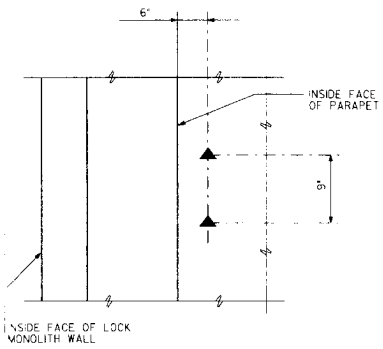

NOTE:
 DETAIL SHOWN ON RIVERWALL SIDE OF
 LOCK MONOLITH. DETAILS ON LANDWALL SIDE OF LOCK



SYMBOL		LEGEND
SECTION	PLAN	INSTRUMENTS AND ABBREVIATIONS
▼	▲	PIEZOMETERS (PI)

RED RIVER WATERWAY-MISSISSIPPI RIVER TO SHREVEPORT, LA.
 U. S. ARMY ENGINEER DISTRICT, VICKSBURG
 CORPS OF ENGINEERS
 VICKSBURG, MISSISSIPPI

LOCK AND DAM NO. 4
 FOUNDATION REPORT
 LOCK INSTRUMENTATION
 SECTIONS

DATE: JANUARY 1996 FILE NO. R-14-206 PLATE 28

3

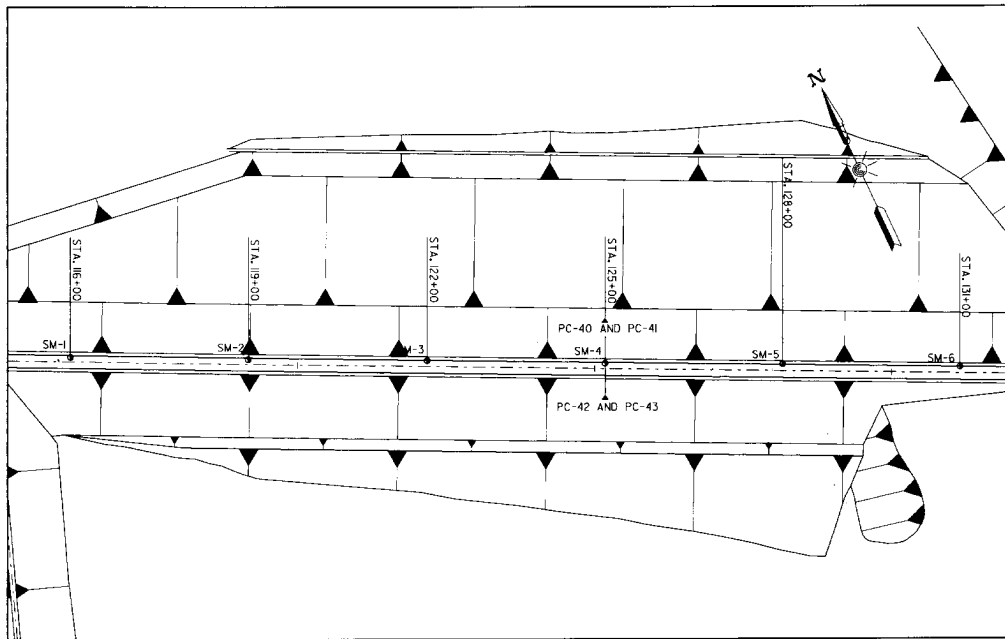

PLAN OF CLOSURE DAM

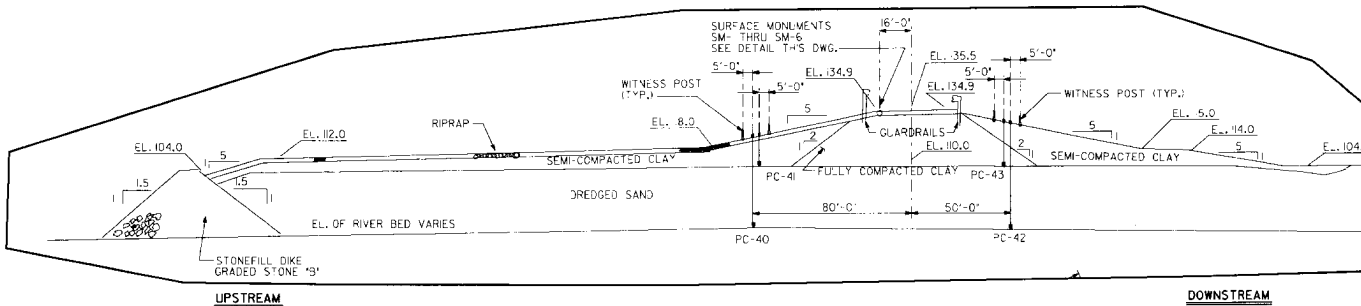
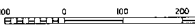

SECTION THRU CLOSURE DAM

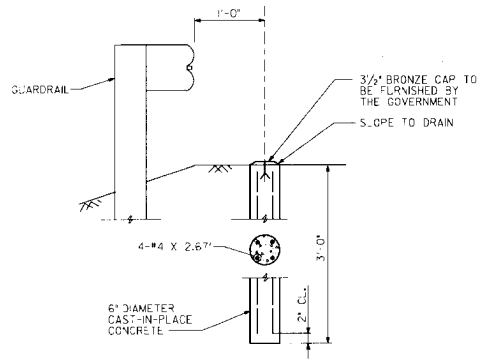
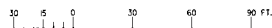

SURFACE MONUMENT DETAIL



UNAPPROVED

1

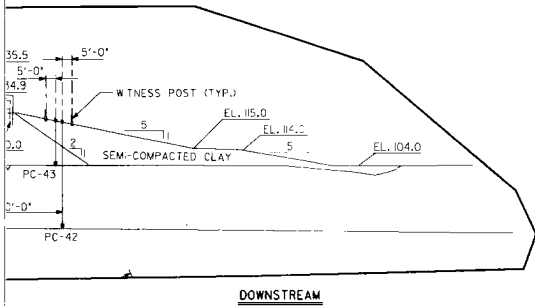
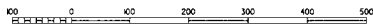
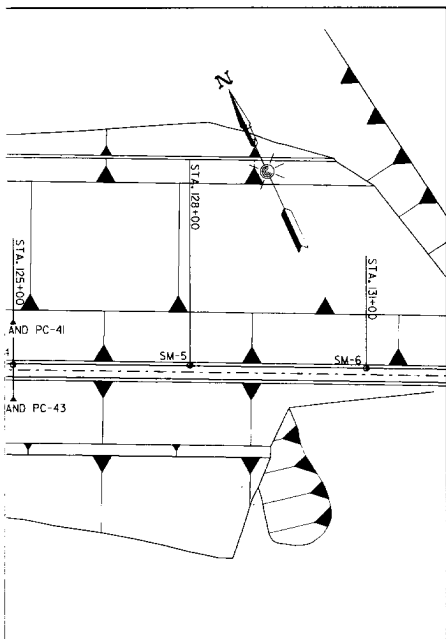

SYMBOL		INSTRUMENTS AND ABBREVIATIONS
SECTION	PLAN	
		PIEZOMETERS (PC)
		SURFACE MONUMENTS (SM)

NOTES:
1. FOR CLOSURE DAM DETAILS SEE PLATE 32

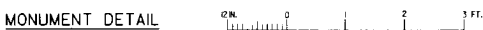
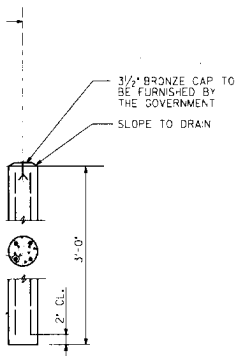

RED RIVER WATERWAY-MISSISSIPPI
U. S. ARMY ENGINEER DISTRICT
CORPS OF ENGINEERS
VICKSBURG, MISSISSIPPI

**LOCK AND DAM
FOUNDATION REPAIR
CLOSURE
INSTRUMENTATION**

DATE: JANUARY 1996 FILE NO.

2

LEGEND		
SYMBOL		INSTRUMENTS AND ABBREVIATIONS
SECTION	PLAN	
▼	▲	PIEZOMETERS (PC)
I	⊙	SURFACE MONUMENTS (SM)

R CLOSURE DAM DETAILS SEE PLATE 32

RED RIVER WATERWAY-MISSISSIPPI RIVER TO SHREVEPORT, LA.
 U. S. ARMY ENGINEER DISTRICT, VICKSBURG
 CORPS OF ENGINEERS
 VICKSBURG, MISSISSIPPI

LOCK AND DAM NO. 4
 FOUNDATION REPORT

CLOSURE DAM
 INSTRUMENTATION

DATE: JANUARY 1996

FILE NO. R-14-207

PLATE 29

3

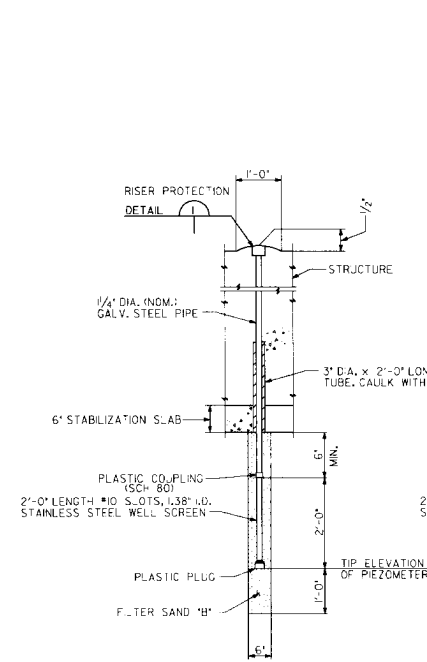

TYPE A PIEZOMETER

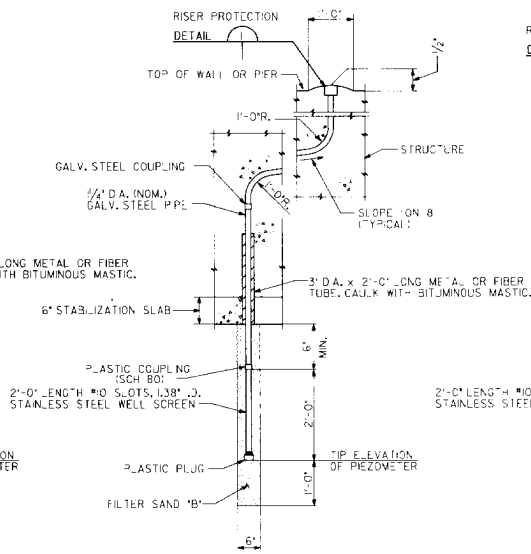

TYPE B PIEZOMETER

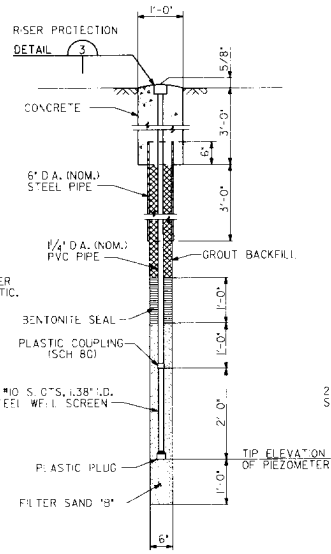

TYPE C PIEZOMETER

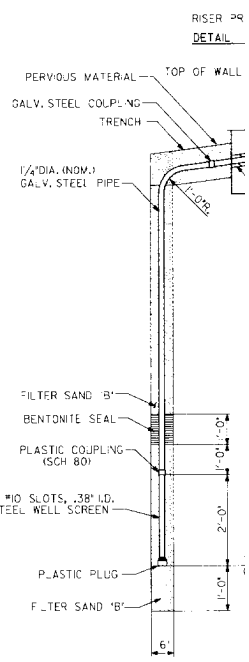

TYPE D PIEZOMETER

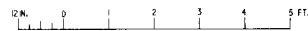

NOTE: FOR TYPE D PIEZOMETER TYPE A, B PIEZOMETER

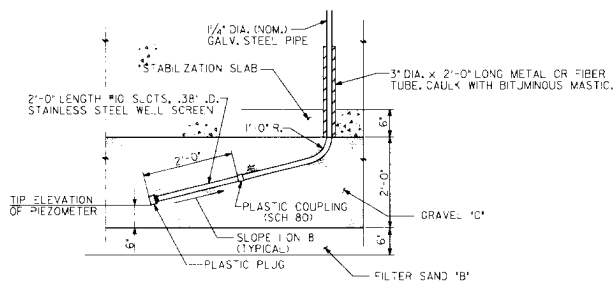

NOTE: WILL APPEAR IN BOTH TYPE A AND TYPE B PIEZOMETERS INSTALLED BENEATH DAM AND STILLING BASIN, DENOTED A AND B ON DRAWING 9/3.

TYPE A, B PIEZOMETER TIP DETAIL FOR TYPE A, B PIEZOMETER INSTALLED IN DRAINAGE BLANKETS

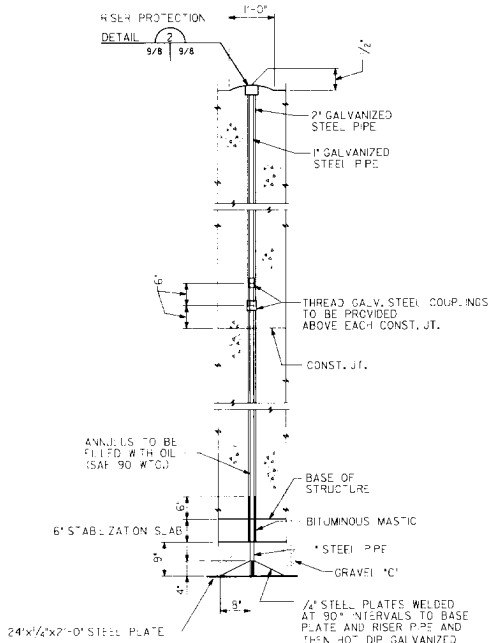
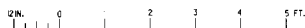

SETTLEMENT PLATE

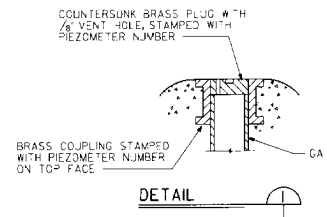

DETAIL

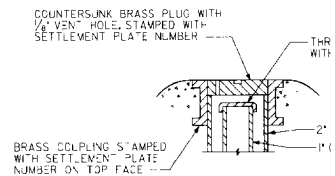

DETAIL

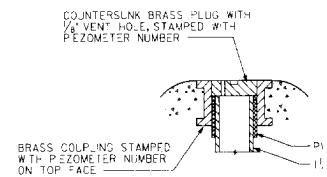

DETAIL

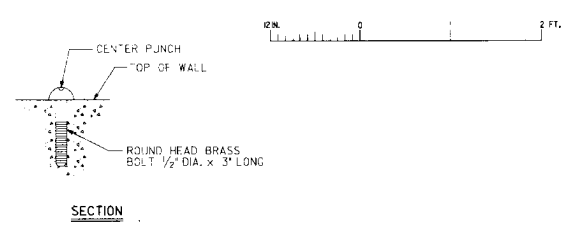
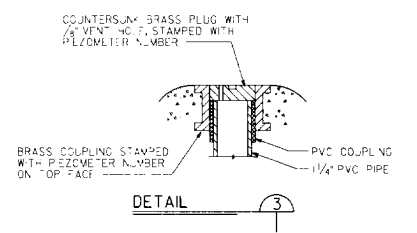
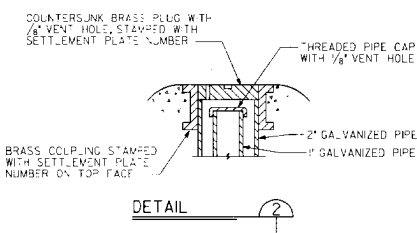
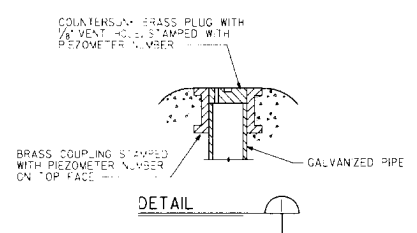
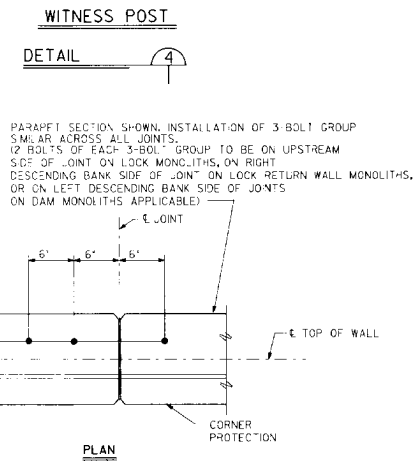
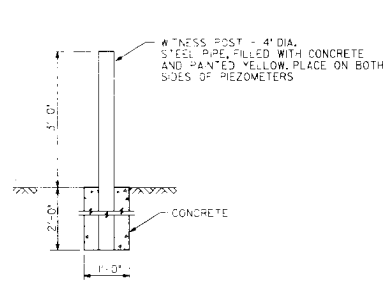
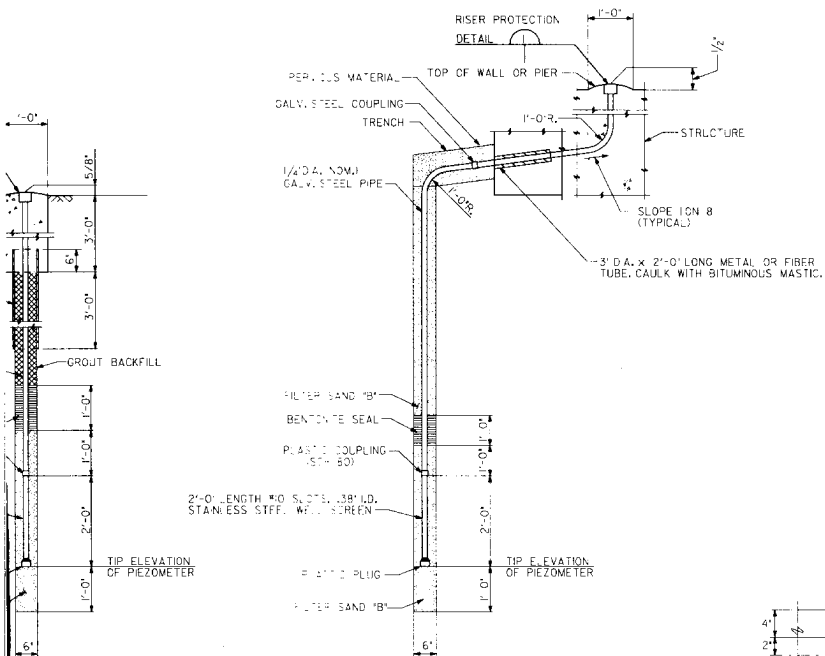

NOTE:
 1. CONNECT GALVANIZED PIPE WITH GALVANIZED COUPLINGS, CONNECT GALVANIZED PIPE TO PLASTIC PIPE WITH PLASTIC COUPLINGS, DIELECTRIC COUPLINGS SHALL BE PLASTIC SCH. 80.

RED RIVER WATERWAY-MISSISSIPPI
 U. S. ARMY ENGINEER DISTRICT
 CORPS OF ENGINEERS
 VICKSBURG, MISSISSIPPI

LOCK AND DAM
 FOUNDATION REPAIR
 CLOSURE
 INSTRUMENTATION

DATE: JANUARY 1996 FILE NO.

2

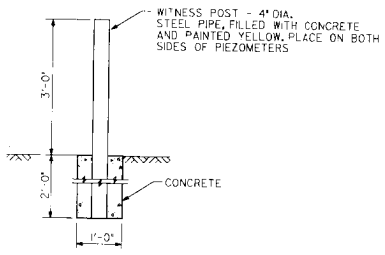
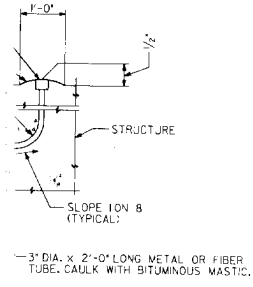

WITNESS POST



PARAPET SECTION SHOWN, INSTALLATION OF 3-BOLT GROUP SIMILAR ACROSS ALL JOINTS. 12 BOLTS OF EACH 3-BOLT GROUP TO BE ON UPSTREAM SIDE OF JOINT ON LOCK MONOLITHS, ON RIGHT DESCENDING BANK SIDE OF JOINT ON LOCK RETURN WALL MONOLITHS, OR ON LEFT DESCENDING BANK SIDE OF JOINTS ON DAM MONOLITHS APPLICABLE.

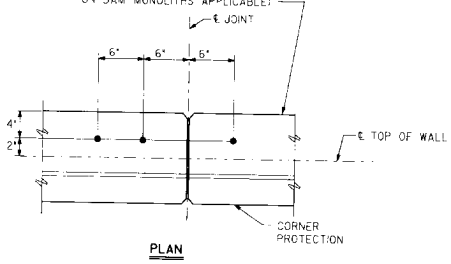

PLAN

TYPICAL REFERENCE BOLT INSTALLATION

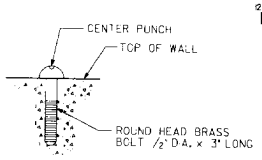

SECTION

REFERENCE BOLT DETAIL

NOTE:

- 1. CONNECT GALVANIZED PIPE WITH GALVANIZED COUPLINGS, CONNECT GALVANIZED PIPE TO PLASTIC PIPE WITH PLASTIC COUPLINGS.
- 2. DIELECTRIC COUPLINGS SHALL BE PLASTIC SC-80.

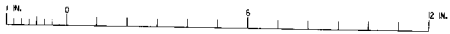

RED RIVER WATERWAY-MISSISSIPPI RIVER TO SHREVEPORT, LA.
 U. S. ARMY ENGINEER DISTRICT, VICKSBURG
 CORPS OF ENGINEERS
 VICKSBURG, MISSISSIPPI

LOCK AND DAM NO. 4
FOUNDATION REPORT
CLOSURE DAM
INSTRUMENTATION DETAILS

DATE: JANUARY 1996 FILE NO. R-14-207 PLATE 30

3

PIEZOMETERS						
DESIGNATION	LOCATION	STATIONS		TIP ELEV.	SOIL TYPE	TYPE
P-1	LBO	0+00.00 L	-0+92.00 D	85.0	SELECT SAND	C
P-2	LBD	2+72.00 L	-0+92.00 D	85.0	SELECT SAND	C
P-3	LBD	5+44.00 L	-0+92.00 D	85.0	SELECT SAND	C
P-4	LBO	8+16.00 L	-0+92.00 D	85.0	SELECT SAND	C
PL-5	L-2	0+35.00 L	-0+44.00 D	57.0	TERTIARY SAND	A
PL-6	L-2	0+35.00 L	0+00.00 D	57.0	TERTIARY SAND	B
PL-7	L-2	0+35.00 L	0+44.00 D	57.0	TERTIARY SAND	A
PL-8	L-4/5	1+50.50 L	0+44.00 D	60.0	TERTIARY SAND	A
PL-9	L-4/5	1+50.50 L	0+00.00 D	60.0	TERTIARY SAND	A
PL-0	L-4/5	1+50.50 L	0+44.00 D	60.0	TERTIARY SAND	A
PL-1	L-8/9	3+44.00 L	0+44.00 D	60.0	TERTIARY SAND	A
PL-12	L-8/9	3+44.00 L	0+00.00 D	60.0	TERTIARY SAND	B
PL-13	L-8/9	3+44.00 L	0+44.00 D	60.0	TERTIARY SAND	A
P-14	L-14/15	6+13.00 L	-0+44.00 D	60.0	TERTIARY SAND	B
P-15	L-4/15	6+13.00 L	0+00.00 D	60.0	TERTIARY SAND	B
P-16	L-4/15	6+13.00 L	0+44.00 D	60.0	TERTIARY SAND	A
PL-17	L-17	8+6.00 L	-0+44.00 D	53.0	TERTIARY SAND	A
PL-18	L-17	8+16.00 L	0+00.00 D	53.0	TERTIARY SAND	B
PL-19	L-17	8+16.00 L	0+44.00 D	53.0	TERTIARY SAND	A
PD-20	D-*	1+03.50 L	1+52.00 D	42.0	TERTIARY SAND	D
PD-2	D-1	0+45.00 L	1+52.00 D	50.0	GRAVEL C	BI
PD-22	D-1	0+53.50 L	1+52.00 D	42.0	TERTIARY SAND	BI
PD-23	D-1	0+56.50 L	1+52.00 D	50.0	GRAVEL C	BI
PD-24	SB-1	1+64.50 L	1+52.00 D	52.0	TERTIARY SAND	D
PD-25	D-2*	1+03.50 L	3+12.00 D	42.0	TERTIARY SAND	BI
PD-26	D-2	-0+45.00 L	3+12.00 D	50.0	GRAVEL C	BI
PD-27	D-2	0+53.50 L	3+12.00 D	42.0	TERTIARY SAND	BI
PD-28	D-2	0+56.50 L	3+12.00 D	50.0	GRAVEL C	BI
PD-29	SB-3	1+64.50 L	3+12.00 D	52.0	GRAVEL C	BI
PD-29A	SB-3*	1+64.50 L	3+12.00 D	52.0	PERVIOUS MATERIAL	B
PD-30	D-4	-0+45.00 L	4+81.00 D	50.0	GRAVEL C	D
PD-31	D-4	0+53.50 L	4+81.00 D	42.0	TERTIARY SAND	B
PD-32	D-4	0+56.50 L	4+81.00 D	50.0	GRAVEL C	B
PD-33	SB-5	1+64.50 L	4+81.00 D	52.0	GRAVEL C	B
PD-34	D-5*	-0+60.00 L	4+95.50 D	60.0	PERVIOUS MATERIAL	A
PD-35	D-5	-0+45.00 L	4+95.50 D	73.0	GRAVEL C	A
PD-36	SB-6	0+73.00 L	4+95.50 D	73.0	GRAVEL C	B
PD-37	D-5*	-0+60.00 L	6+06.50 D	75.0	PERVIOUS MATERIAL	D
PD-38	D-5	-0+45.00 L	6+06.50 D	73.0	GRAVEL C	BI
PD-39	SB-8	0+73.00 L	6+06.50 D	73.0	GRAVEL C	BI
PC-40	CD	25+00.00 S	80.00 LEFT	85.0	QUATERNARY SAND	C
PC-41	CD	125+00.00 S	80.00 LEFT	105.0	DREDGED SAND	C
PC-42	CD	25+00.00 S	50.00 RIGHT	85.0	QUATERNARY SAND	C
PC-43	CD	125+00.00 S	50.00 RIGHT	105.0	DREDGED SAND	C
PL-44	L-6/7*	2+60.00 L	0+80.00 D	65.0	SELECT SAND	D
PL-45	L-8/9*	3+90.00 L	0+80.00 D	65.0	SELECT SAND	D
PL-46	L-12/13*	5+20.00 L	0+80.00 D	65.0	SELECT SAND	D

* ADJACENT TO

** TYPE D MODIFIED, SEE PLATE 30

SURFACE MONUMENTS				
DESIGNATION	LOCATION	STATION	DIST. FROM CENTERLINE	ELEVATION (FT NGVD)
SM-1	CD	16+00.00S	16.00 LEFT	135.00
SM-2	CD	19+00.00S	16.00 LEFT	135.00
SM-3	CD	22+00.00S	16.00 LEFT	135.00
SM-4	CD	125+00.00S	16.00 LEFT	35.00
SM-5	CD	128+00.00S	16.00 LEFT	35.00
SM-6	CD	131+00.00S	16.00 LEFT	135.00

REFERENCE BOLT GROUPS				
DESIGNATION	MONOLITHS	NO. OF BOLTS IN GROUP	STAT	
UPSTREAM RETURN WALL				
RB-2	UR-4	1	-2+33.83	L
RB-3	UR-4 AND UR-3	3	-2+33.83	L
RB-4	UR-3 AND UR-2	3	-2+33.83	L
RB-5	UR-2 AND UR-1	3	-2+33.83	L
RB-5	UR- AND US CUARDWALL	3	-2+33.83	L
LANDSIDE OF LOCK				
RB-6	JS GUARDWALL AND L-1	3	-1+75.00	L
RB-7	L-1 AND L-2	3	-0+78.00	L
RB-8	L-2 AND L-3	3	0+51.00	L
RB-9	L-3 AND L-4/5	3	1+29.00	L
RB-10	L-4/5 AND L-6/7	3	2+15.00	L
RB-11	L-6/7 AND L-8/9	3	3+01.00	L
RB-12	L-8/9	3	3+44.00	L
RB-13	L-8/9 AND L-10/11	3	4+99.00	L
RB-14	L-10/11 AND L-12/13	3	4+73.00	L
RB-15	L-12/13 AND L-14/15	3	5+59.00	L
RB-16	L-14/15 AND L-16	3	6+45.00	L
RB-17	L-16 AND L-17	3	7+23.00	L
RB-18	L-17 AND L-18	3	8+32.00	L
RB-19	L-18 AND DR-1	3	9+8.33	L
DOWNSTREAM RETURN WALL				
RB-20	DR-1 AND DR-2	3	9+18.33	L
RB-21	DR-2 AND DR-3	3	9+18.33	L
RB-22	DR-3	1	9+18.33	L
UPSTREAM GUIDEWALL				
RB-23	UG-1	3	-8+73.83	L
RB-24	UG-1 AND UG-2	3	-8+23.00	L
RB-25	UG-2 AND UG-3	3	-7+15.00	L
RB-26	UG-3 AND UG-4	3	-6+07.00	L
RB-27	UG-4 AND UG-5	3	-4+99.00	L
RB-28	UG-5 AND UG-6	3	-3+91.00	L
RB-29	UG-6 AND UG-7	3	-2+83.00	L
RB-30	UG-7 AND L-1	3	-1+75.00	L
RB-31	L-1 AND L-2	3	-0+78.00	L
RB-32	L-2 AND L-3	3	0+51.00	L
RB-33	L-3 AND L-4/5	3	1+29.00	L
RB-34	L-4/5 AND L-6/7	3	2+15.00	L
RB-35	L-6/7 AND L-8/9	3	3+01.00	L
RB-36	L-8/9	3	3+44.00	L
RB-37	L-8/9 AND L-10/11	3	3+87.00	L
RB-38	L-10/11 AND L-12/13	3	4+73.00	L
RB-39	L-12/13 AND L-14/15	3	5+59.00	L
RB-40	L-14/15 AND L-16	3	6+45.00	L
RB-41	L-16 AND L-17	3	7+23.00	L
RB-42	L-17 AND L-18	3	8+32.00	L
RB-43	L-18 AND DG-1	3	9+9.50	L
DOWNSTREAM GUIDEWALL				
RB-44	DG-1 AND DG-2	3	0+19.50	L
RB-45	DG-2 AND DG-3	3	1+19.50	L
RB-46	DG-3 AND DG-4	3	2+19.50	L
RB-47	DG-4 AND DG-5	3	3+19.50	L
RB-48	DG-5 AND DG-6	3	4+19.50	L
RB-49	DG-6 AND DG-7	3	5+19.50	L
RB-50	DG-7	1	5+68.33	L
CUTOFF WALL				
RB-51	CUTOFF WALL AND L-2	3	0+01.50	L
RB-52	CUTOFF WALL AND D-1	3	0+01.50	L
TAINTER GATED SPILLWAY				
RB-53	D-1	1	-0+31.00	L
RB-54	D-1	1	0+00.62	L
RB-55	D-1	1	-0+31.00	L
RB-56	D-1	1	0+00.62	L
RB-57	D-2	1	0+00.62	L
RB-58	D-2	1	-0+31.00	L
RB-59	D-3	1	0+00.62	L
RB-60	D-3	1	-0+31.00	L
RB-61	D-4	1	0+00.62	L
RB-62	D-4	1	-0+31.00	L
RB-63	D-4	1	0+00.62	L
RB-64	D-4	1	0+00.62	L
CREST GATED SPILLWAY				
RB-65	D-5	1	-0+25.00	L
RB-66	D-5	1	0+11.62	L
RB-67	D-5	1	-0+25.00	L
RB-68	D-5	1	0+11.62	L
OVERFLOW WALL				
RB-69	OW-1	1	0+5.50	L
RB-70	OW-1 AND OW-2	3	0+5.50	L
RB-71	OW-2 AND OW-3	3	0+5.50	L
RB-72	OW-3	1	0+5.50	L

REFERENCE BOLT GROUPS

DESIGNATION	MONOLITHS	NO. OF BOLTS IN GROUP	STATIONS	
UPSTREAM RETURN WALL				
RB-1	UR-4	1	-2+33.83 L	-2+59.50 D
RB-2	UR-4 AND UR-3	3	-2+33.83 L	-2+04.50 D
RB-3	UR-3 AND UR-2	3	-2+33.83 L	-+63.00 D
RB-4	UR-2 AND UR-1	3	-2+33.83 L	-+21.50 D
RB-5	UR-1 AND US GJARDWALL	3	-2+33.83 L	-+80.00 D
LANDSIDE OF LOCK				
RB-6	US GUARDWALL AND L-1	3	-1+75.00 L	-0+43.17 D
RB-7	L-1 AND L-2	3	-0+78.00 L	-0+43.17 D
RB-8	L-2 AND L-3	3	0+51.00 L	-0+43.17 D
RB-9	L-3 AND L-4/5	3	1+29.00 L	-0+43.17 D
RB-10	L-4/5 AND L-6/7	3	2+15.00 L	-0+43.17 D
RB-11	L-6/7 AND L-8/9	3	3+01.00 L	-0+43.17 D
RB-12	L-8/9	3	3+44.00 L	-0+43.17 D
RB-13	L-8/9 AND L-10/11	3	3+87.00 L	-0+43.17 D
RB-14	L-10/11 AND L-12/3	3	4+73.00 L	-0+43.17 D
RB-15	L-12/13 AND L-14/5	3	5+59.00 L	-0+43.17 D
RB-16	L-14/5 AND L-16	3	6+45.00 L	-0+43.17 D
RB-17	L-16 AND L-17	3	7+23.00 L	-0+43.17 D
RB-18	L-17 AND L-18	3	8+32.00 L	-0+43.17 D
RB-19	L-18 AND DR-1	3	9+18.33 L	-0+80.00 D
DOWNSTREAM RETURN WALL				
RB-20	DR-1 AND DR-2	3	9+18.33 L	-1+32.00 D
RB-21	DR-2 AND DR-3	3	9+18.33 L	-+84.00 D
RB-22	DR-3	1	9+18.33 L	-2+35.00 D
UPSTREAM GUIDEWALL				
RB-23	JG-	1	-8+73.83 L	0+52.00 D
RB-24	UG-1 AND UG-2	3	-8+23.00 L	0+43.17 D
RB-25	UG-2 AND UG-3	3	-7+15.00 L	0+43.17 D
RB-26	UG-3 AND UG-4	3	-6+07.00 L	0+43.17 D
RB-27	UG-4 AND UG-5	3	-4+99.00 L	0+43.17 D
RB-28	UG-5 AND UG-6	3	-3+19.00 L	0+43.17 D
RB-29	UG-6 AND UG-7	3	-2+83.00 L	0+43.17 D
DOWNSTREAM GUIDEWALL				
RB-30	UG-7 AND L-1	3	-1+75.00 L	0+43.17 D
RB-31	L-1 AND L-2	3	-0+78.00 L	0+43.17 D
RB-32	L-2 AND L-3	3	0+51.00 L	0+43.17 D
RB-33	L-3 AND L-4/5	3	1+29.00 L	0+43.17 D
RB-34	L-4/5 AND L-6/7	3	2+15.00 L	0+43.17 D
RB-35	L-6/7 AND L-8/9	3	3+01.00 L	0+43.17 D
RB-36	L-8/9	3	3+44.00 L	0+43.17 D
RB-37	L-8/9 AND L-10/11	3	3+87.00 L	0+43.17 D
RB-38	L-10/11 AND L-12/13	3	4+73.00 L	0+43.17 D
RB-39	L-12/13 AND L-14/5	3	5+59.00 L	0+43.17 D
RB-40	L-14/5 AND L-16	3	6+45.00 L	0+43.17 D
RB-41	L-16 AND L-17	3	7+23.00 L	0+43.17 D
RB-42	L-17 AND L-18	3	8+32.00 L	0+43.17 D
RB-43	L-18 AND DG-1	3	9+19.50 L	0+43.17 D
DOWNSTREAM GUIDEWALL				
RB-44	DG-1 AND DG-2	3	10+19.50 L	0+43.17 D
RB-45	DG-2 AND DG-3	3	1+19.50 L	0+43.17 D
RB-46	DG-3 AND DG-4	3	12+19.50 L	0+43.17 D
RB-47	DG-4 AND DG-5	3	13+19.50 L	0+43.17 D
RB-48	DG-5 AND DG-6	3	4+19.50 L	0+43.17 D
RB-49	DG-6 AND DG-7	3	5+19.50 L	0+43.17 D
RB-50	DG-7	1	15+68.33 L	0+52.00 D
CUTOFF WALL				
RB-51	CUTOFF WALL AND L-2	3	0+01.50 L	0+84.00 D
RB-52	CUTOFF WALL AND D-1	3	0+01.50 L	1+42.00 D
TAINTER GATED SPILLWAY				
RB-53	D-1	1	-0+31.00 L	1+46.50 D
RB-54	D-1	1	0+00.62 L	1+51.50 D
RB-55	D-1	1	-0+31.00 L	2+5.00 D
RB-56	D-1	1	0+00.62 L	2+7.00 D
RB-57	D-2	1	-0+31.00 L	2+83.00 D
RB-58	D-2	1	0+00.62 L	2+85.00 D
RB-59	D-3	1	-0+31.00 L	3+51.00 D
RB-60	D-3	1	0+00.62 L	3+53.00 D
RB-61	D-4	1	-0+31.00 L	4+9.00 D
RB-62	D-4	1	0+00.62 L	4+21.00 D
RB-63	D-4	1	-0+31.00 L	4+87.00 D
RB-64	D-4	1	0+00.62 L	4+89.00 D
CREST GATED SPILLWAY				
RB-65	D-5	1	-0+25.00 L	4+95.50 D
RB-66	D-5	1	0+16.2 L	4+95.50 D
RB-67	D-5	1	-0+25.00 L	6+06.50 D
RB-68	D-5	1	0+16.2 L	6+06.50 D
OVERFLOW WALL				
RB-69	OW-1	1	0+5.50 L	6+11.50 D
RB-70	OW-1 AND OW-2	3	0+5.50 L	6+62.33 D
RB-71	OW-2 AND OW-3	3	0+5.50 L	7+13.67 D
RB-72	OW-3	1	0+5.50 L	7+64.50 D

SETTLEMENT PLATES

DESIGNATION	MONOLITH	STATIONS		ELEVATION
TAINTER GATED SPILLWAY				
SP-1	D-1	-0+20.50 L	1+44.50 D	49.17
SP-2	D-4	-0+20.50 L	4+85.00 D	49.17
CREST GATED SPILLWAY				
SP-3	D-5	-0+9.75 L	4+95.50 D	72.67
SP-4	D-5	0+19.75 L	6+06.50 D	72.67

NOTES:

1. 'L' BEHIND STATION DENOTES LOCK C.L. STATIONING
2. 'D' BEHIND STATION DENOTES DAM AXIS STATIONING
3. 'S' BEHIND STATION DENOTES SOUTH ACCESS ROAD STATIONING
4. LOCATION LEGEND:

CD CLOSURE DAM
D DAM
L LOCK
UG UPSTREAM GUIDEWALL
DG DOWNSTREAM GUIDEWALL
C CUTOFF WALL
OW OVERFLOW WALL
LBO LOCK BACKFILL DRAIN
SB STILLING BASIN
S SOUTH ACCESS ROAD
UR UPSTREAM RETURN WALL
DR DOWNSTREAM RETURN WALL

5. DESIGNATION LEGEND:

PL PIEZOMETER - LOCK
PD PIEZOMETER - DAM
PC PIEZOMETER - CLOSURE DAM
SM SURFACE MONUMENT
RB REFERENCE BOLT
SP SETTLEMENT PLATE

RED RIVER WATERWAY
U. S. ARMY ENGINEERING
CORPS
VICKSBURG

LOCK AND
FOUND.
LOCK
INSTRUMENT

DATE: JANUARY 1996

2

SETTLEMENT PLATES			
DESIGNATION	MONOLITH	STATIONS	ELEVATION
TAINTER GATED SPILLWAY			
SP-1	D-1	0+27.50 D	+44.50 D
SP-2	D-4	0+27.50 D 4+85.00 D	49.17 49.17
CREST GATED SPILLWAY			
SP-3	D-5	4+95.50 D	72.67
SP-4	D-5	6+06.50 D	72.67

NOTES:

1. 'L' BEHIND STATION DENOTES LOCK C/L. STATIONING
2. 'D' BEHIND STATION DENOTES DAM AXIS STATIONING
3. 'S' BEHIND STATION DENOTES SOUTH ACCESS ROAD STATIONING
4. LOCATION LEGEND:

- CD CLOSURE DAM
- D DAM
- L LOCK
- UG UPSTREAM GUIDEWALL
- DG DOWNSTREAM GUIDEWALL
- C CUTOFF WALL
- OW OVERFLOW WALL
- LB LOCK BACKFILL DRAIN
- SB STILLING BASIN
- S SOUTH ACCESS ROAD
- UR UPSTREAM RETURN WALL
- DR DOWNSTREAM RETURN WALL

5. DESIGNATION LEGEND:

- PL PIEZOMETER - LOCK
- PD PIEZOMETER - DAM
- PC PIEZOMETER - CLOSURE DAM
- SM SURFACE MONUMENT
- RB REFERENCE BOLT
- SP SETTLEMENT PLATE

RED RIVER WATERWAY-MISSISSIPPI RIVER TO SHREVEPORT, LA.
 U. S. ARMY ENGINEER DISTRICT, VICKSBURG
 CORPS OF ENGINEERS
 VICKSBURG, MISSISSIPPI

LOCK AND DAM NO. 4
 FOUNDATION REPORT
LOCK AND DAM
 INSTRUMENTATION TABULATION

DATE: JANUARY 1996 FILE NO. R-14-206 PLATE 31

3

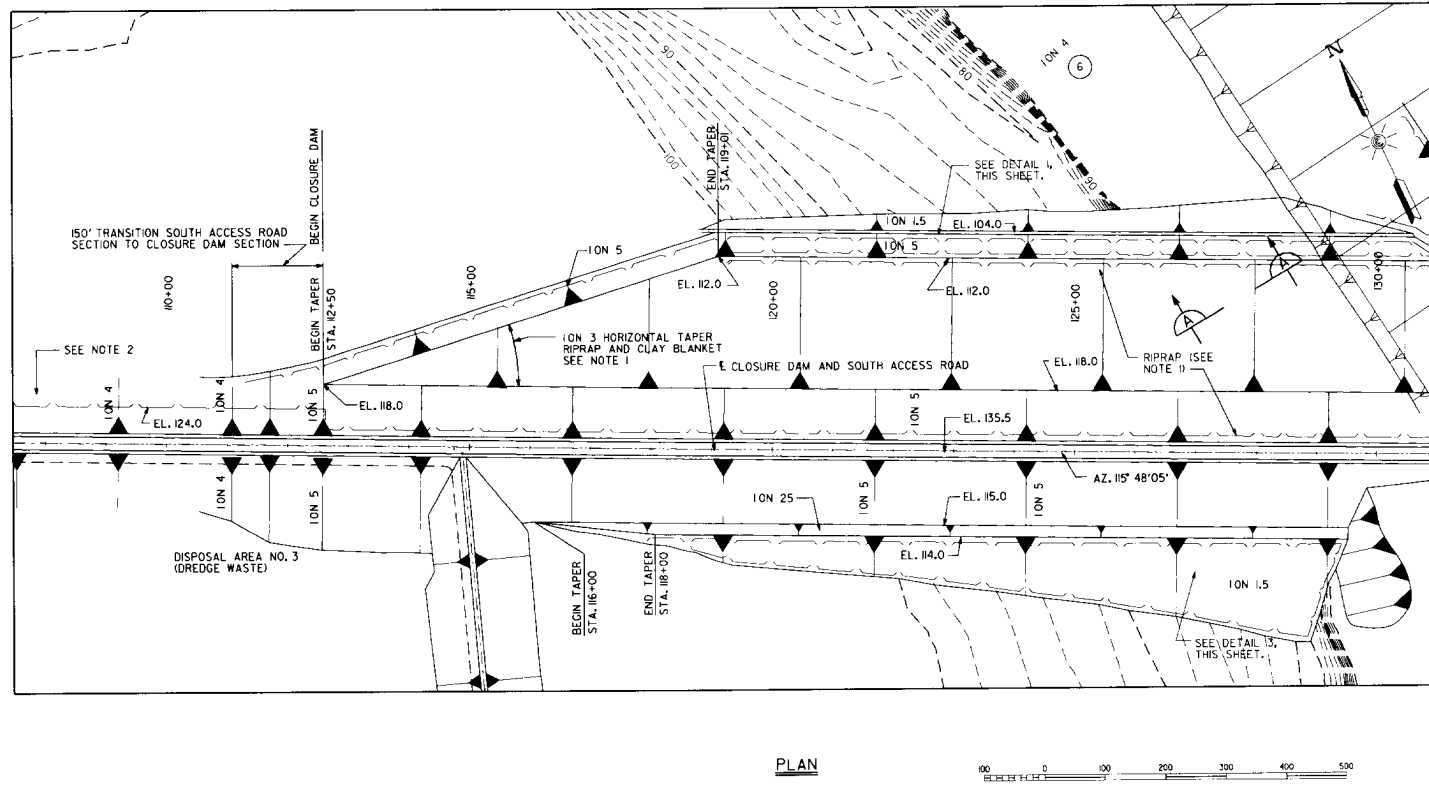
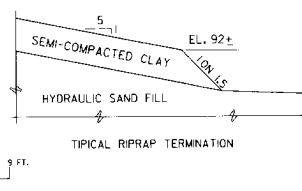
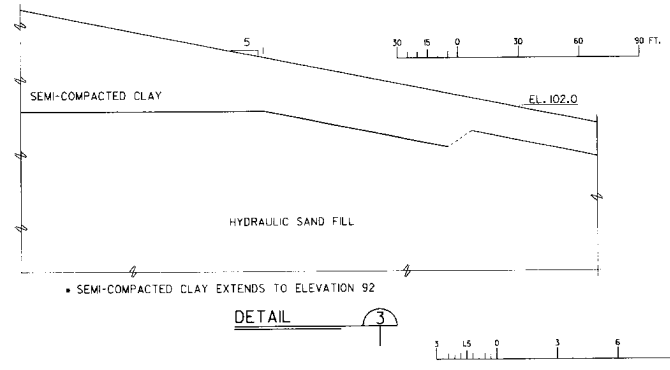
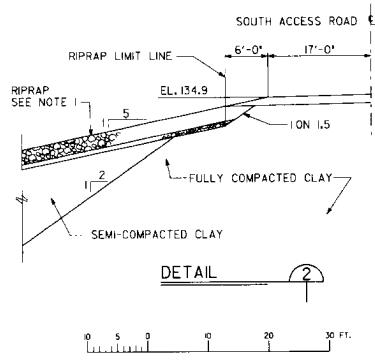
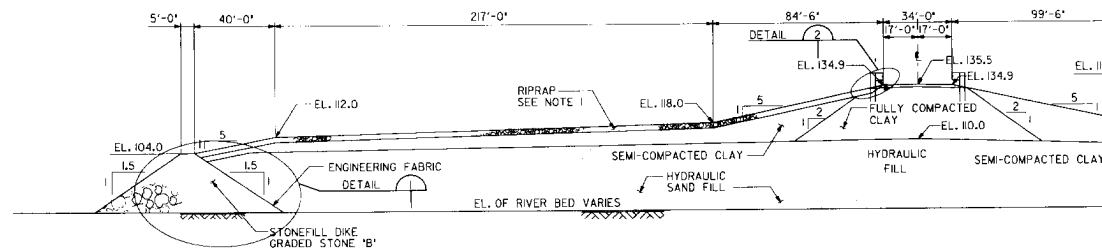
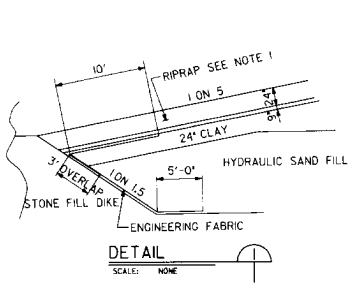

104273.00

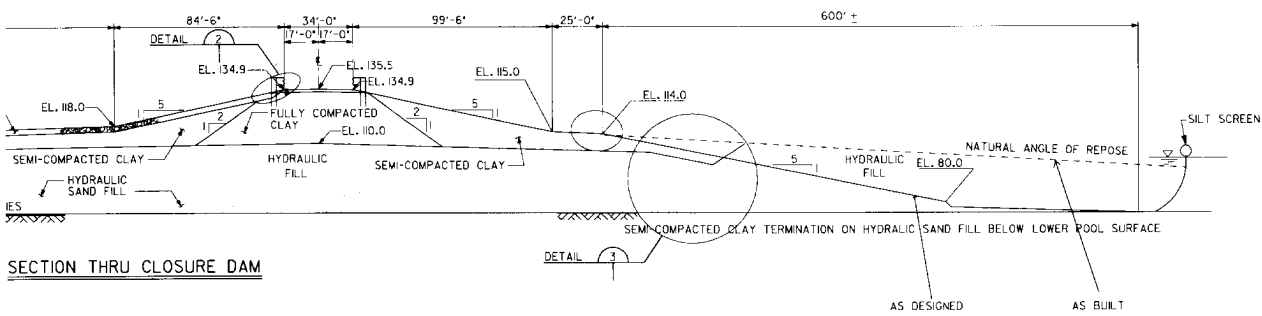

SECTION THRU CLOSURE DAM

30 60 90 FT.

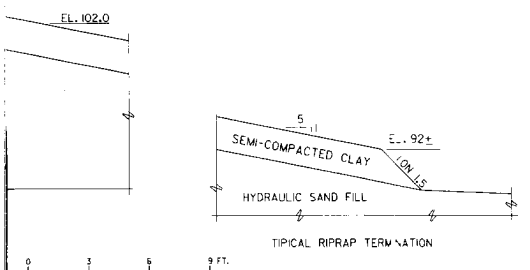

0 3 6 9 FT.

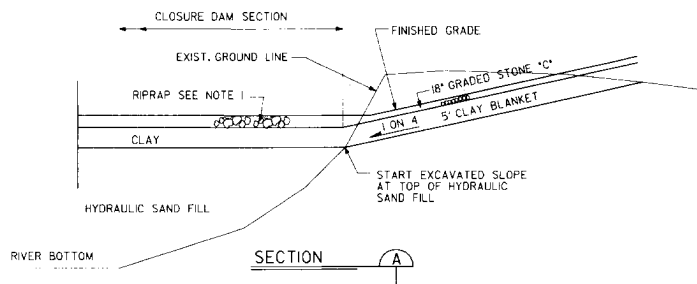
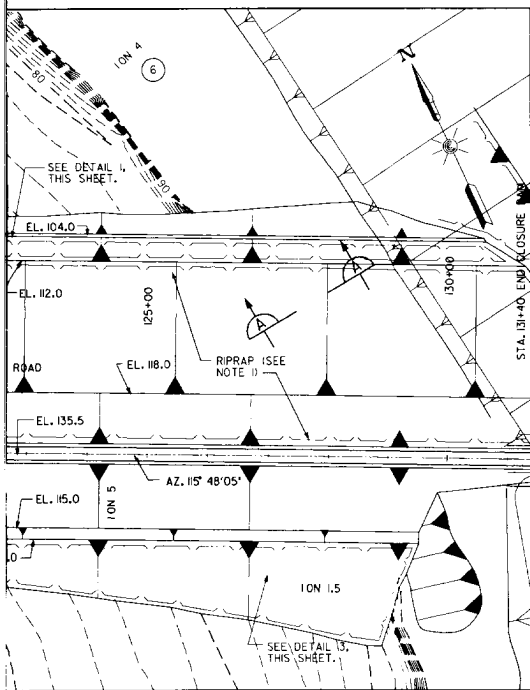

- NOTES:
1. 24" THICK BLANKET OF RIPRAP R200 ON 9" BEDDING MATERIAL NO. 2.
 2. RIPRAP DETELED ON DOWN STREAM FACE OF CLOSURE DAM.
- ALL SEMI-COMPACTED CLAY AS SHOWN

RIPRAP LEGEND:

(6) - 18" GRADED STONE "C".

RED RIVER WATERWAY-MISSOURI
 U. S. ARMY ENGINEER
 CORPS OF
 WICKSBURG,
**LOCK AND
 FOUNDATION**
**CLOSURE
 SECTIONS**
 DATE: JANUARY 1996

2

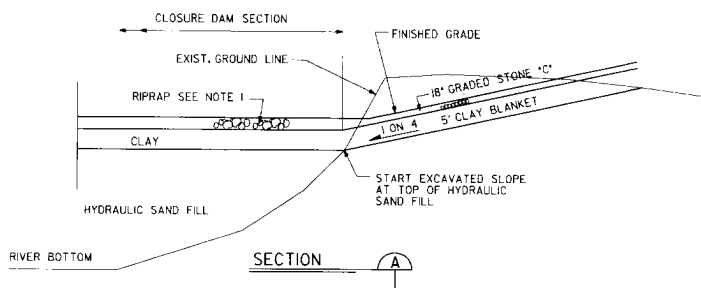
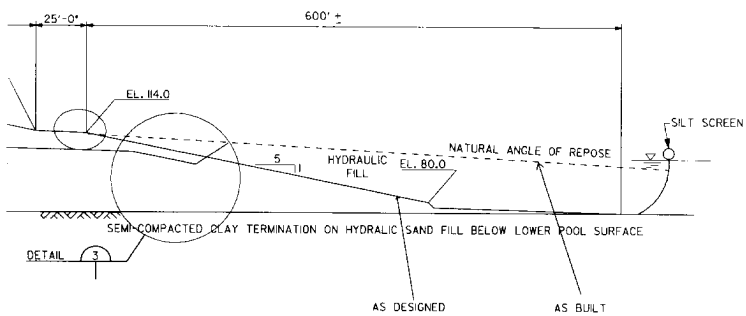

- NOTES:
1. 24" THICK BLANKET OF RIPRAP R200 ON 3" BEDDING MATERIAL NO. 2.
 2. RIPRAP DETELED ON DOWN STREAM FACE OF CLOSURE DAM.
- ALL SEMI-COMPACTED CLAY AS SHOWN

RIPRAP LEGEND:

- ⑥ - 18" GRADED STONE 'C'.

RED RIVER WATERWAY - MISSISSIPPI RIVER TO SHREVEPORT, LA.
 U. S. ARMY ENGINEER DISTRICT, VICKSBURG
 CORPS OF ENGINEERS
 VICKSBURG, MISSISSIPPI

LOCK AND DAM NO. 4
 FOUNDATION REPORT

CLOSURE DAM PLAN
 SECTIONS AND DETAILS

DATE: JANUARY 1996

FILE NO. R-14-206

PLATE 32

3