

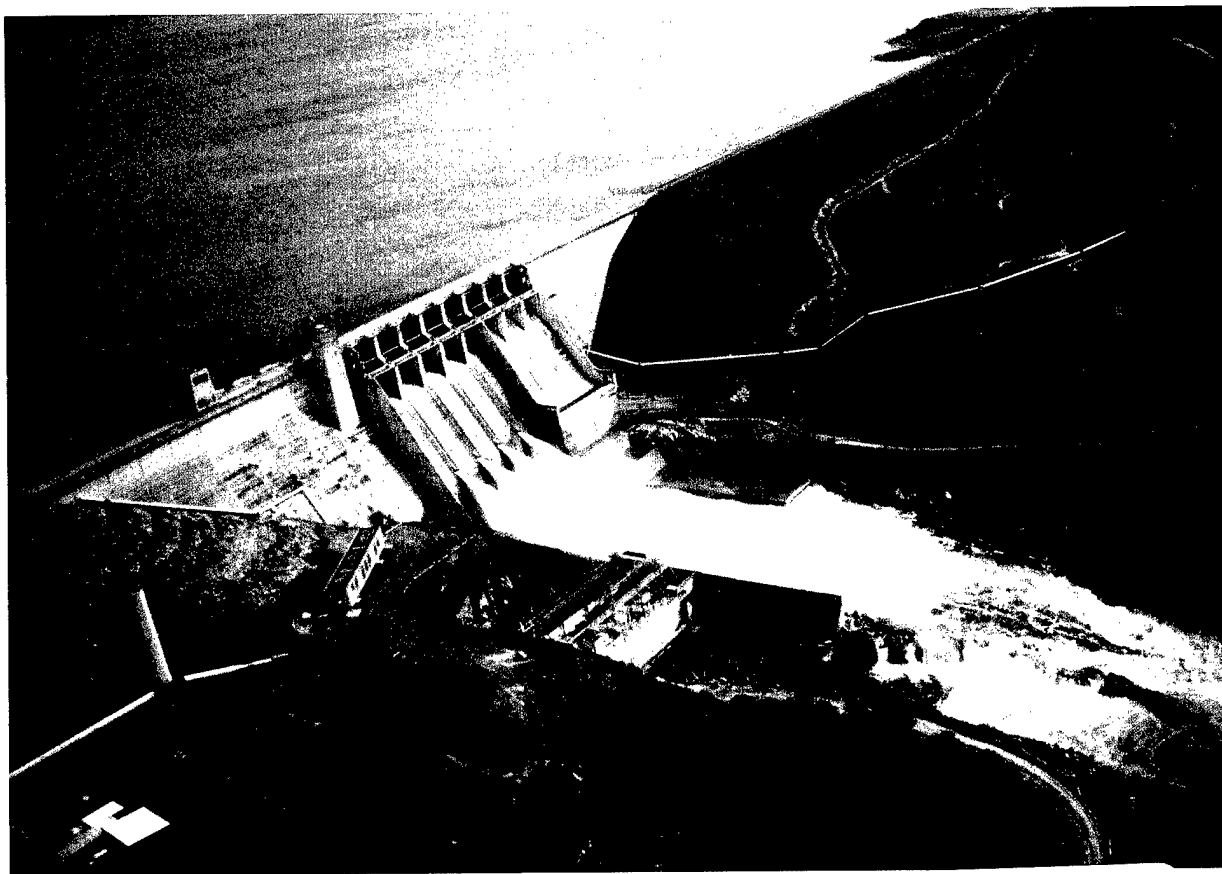

**US Army Corps  
of Engineers**  
Hydrologic Engineering Center

# **Water Control Data System (WCDS) Past, Present and Future**



September 1995

19961018 078

DTIC QUALITY INSPECTED 3

Approved for Public Release. Distributed Unlimited.

**RD-39**

# REPORT DOCUMENTATION PAGE

Form Approved  
OMB No. 0704-0188

Public reporting burden for this collection of information is estimated to average 1 hour per response, including the time for reviewing instructions, searching existing data sources, gathering and maintaining the data needed, and completing and reviewing the collection of information. Send comments regarding this burden estimate or any other aspect of this collection of information, including suggestions for reducing this burden, to Washington Headquarters Services, Directorate for Information Operations and Reports, 1215 Jefferson Davis Highway, Suite 1204, Arlington, VA 22202-4302, and to the Office of Management and Budget, Paperwork Reduction Project (0704-0188), Washington, DC 20503.

1. AGENCY USE ONLY (Leave blank)	2. REPORT DATE <b>September 1995</b>	3. REPORT TYPE AND DATES COVERED <b>Final</b>	
4. TITLE AND SUBTITLE <b>Water Control Data System (WCDS) Past, Present, and Future</b>		5. FUNDING NUMBERS	
6. AUTHOR(S) <b>Darryl W. Davis</b>		8. PERFORMING ORGANIZATION REPORT NUMBER <b>RD-39</b>	
7. PERFORMING ORGANIZATION NAME(S) AND ADDRESS(ES) <b>Hydrologic Engineering Center 609 Second Street Davis, CA 95616-4687</b>		10. SPONSORING / MONITORING AGENCY REPORT NUMBER	
9. SPONSORING / MONITORING AGENCY NAME(S) AND ADDRESS(ES) <b>HQUSACE CECW-EH-W Washington, DC</b>		11. SUPPLEMENTARY NOTES	
12a. DISTRIBUTION / AVAILABILITY STATEMENT <b>Distribution is unlimited.</b>		12b. DISTRIBUTION CODE	
13. ABSTRACT (Maximum 200 words) <b>The Water Control Data System (WCDS) is the data acquisition, management, modeling and decision support system that serves the Corps of Engineers water control mission of operating more than 500 reservoirs. This report documents the history, status, and future plans for improving WCDS. The existing WCDS is described as the circa 1988-1990 snapshot to provide a base for comparing improvement plans. Improvement plans include replacing computer hardware, data acquisition hardware, creation of a corporate water control data base system, and upgrade and development of new decision support software.</b>			
14. SUBJECT TERMS <b>Reservoirs, water control, data acquisition, weather data</b>		15. NUMBER OF PAGES <b>100</b>	16. PRICE CODE
17. SECURITY CLASSIFICATION OF REPORT <b>Unclassified</b>	18. SECURITY CLASSIFICATION OF THIS PAGE <b>Unclassified</b>	19. SECURITY CLASSIFICATION OF ABSTRACT <b>Unclassified</b>	20. LIMITATION OF ABSTRACT <b>NA</b>

# DISCLAIMER NOTICE

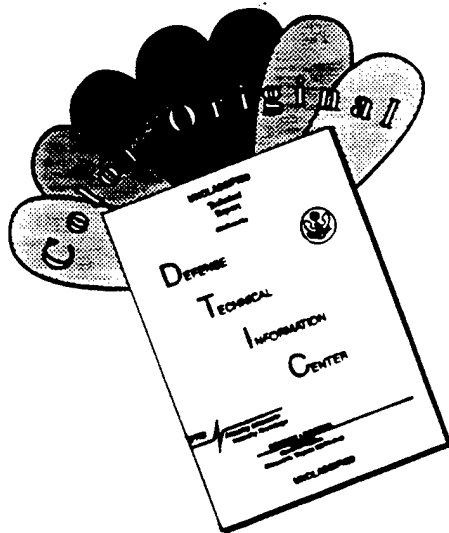

THIS DOCUMENT IS BEST QUALITY AVAILABLE. THE COPY FURNISHED TO DTIC CONTAINED A SIGNIFICANT NUMBER OF COLOR PAGES WHICH DO NOT REPRODUCE LEGIBLY ON BLACK AND WHITE MICROFICHE.

# **Water Control Data System (WCDS) Past, Present, and Future**

September 1995

US Army Corps of Engineers  
Hydrologic Engineering Center  
609 Second Street  
Davis, CA 95616-4687

(916) 756-1104

**RD-39**

# Table of Contents

Chapter	Page
Preface .....	vii
1 Introduction .....	1
1.1 Purpose and Scope .....	1
1.2 Document Structure .....	1
2 Water Control Management .....	3
2.1 Corps Water Control Mission .....	3
2.1.1 Definitions. ....	3
2.2 Water Control Decision Process .....	5
2.2.1 Strategic Decisions. ....	5
2.2.2 Real Time Decisions. ....	5
2.2.3 Distribution of Operational Information .....	6
2.2.4 Example Decision Scenarios .....	6
2.3 Corps Water Control Management Structure, Staff .....	8
2.4 Role of Water Control Data System (WCDS) .....	9
2.5 WCDS Functions .....	9
2.5.1 Data Acquisition .....	10
2.5.2 Data Storage, Management, and Reporting .....	10
2.5.3 Modeling, Forecasting, and Simulation .....	11
2.6 WCDS Oversight .....	11
2.6.1 Field Technical Advisory Group (FTAG) .....	11
2.6.2 Policy Guidance .....	11
2.6.3 Annual Reports .....	11
3 Water Control Data System circa 1988-1990 .....	13
3.1 Background, History, General Functionality .....	13
3.2 Computers and Related Hardware .....	13
3.2.1 Computer and Data Acquisition/Communications Hardware .....	15
3.2.2 Computer Life Cycle Replacement .....	16
3.3 WCDS Software .....	16
3.3.1 Software Overview, Origin .....	16
3.3.2 Software Characteristics .....	19
3.4 WCDS Hardware and Software Maintenance and Support .....	19
3.4.1 Hardware Service and Support .....	19

## Table of Contents (continued)

Chapter	Page
3.4.2 Corps-wide Software .....	20
3.4.3 Locally Developed Software .....	20
3.5 circa 1988-1990 WCDS System Cost .....	20
4 Water Control Data System Modernization Project (post circa 1988-1990) .....	23
4.1 Overview .....	23
4.2 Needs/Opportunities .....	23
4.2.1 Needs .....	23
4.2.2 New Network and Workstation Technology .....	23
4.2.3 New Data Sources .....	24
4.2.4 Improved Data Management Technology .....	25
4.2.5 New Modeling, Forecasting and Simulation Tools .....	25
4.3 Software Engineering .....	25
4.3.1 Overview .....	25
4.3.2 User Requirements .....	25
4.3.3 Software Design .....	25
4.3.4 Coding Languages and Coding .....	26
4.4 Hardware and Software Requirements .....	26
4.4.1 Hardware Requirements .....	26
4.4.1.1 Computer Life Cycle Replacement .....	26
4.4.1.2 Field Instruments, Acquisition, Communications Hardware .....	27
4.4.2 Data Acquisition .....	29
4.4.2.1 GOES .....	29
4.4.2.2 National Weather Service Data .....	29
4.4.2.3 NEXRAD .....	30
4.4.2.4 Imagery .....	31
4.4.2.5 Other Data Sources .....	31
4.4.2.6 Decoding .....	31
4.4.2.7 Transformation .....	32
4.4.2.8 Validation .....	32
4.4.3 Data Storage, Management, and Reporting .....	33
4.4.3.1 Data Types and Availability .....	33
4.4.3.2 Database System .....	33
4.4.3.3 Dissemination and Reporting .....	33
4.4.3.4 Archiving .....	34
4.4.3.5 Control and Visualization Interface .....	34
4.4.4 Modeling, Forecasting, Simulation .....	39
4.4.4.1 Flow Forecasting .....	39

## Table of Contents (continued)

Chapter	Page
4.4.4.2 Reservoir System Simulation. ....	40
4.4.4.3 Water Quality, Sediment Transport and Hydrodynamic Simulations .....	40
4.4.4.4 Impact Analysis. ....	41
4.4.4.5 Forecast Evaluation .....	42
4.4.5 Software System .....	42
4.4.6 Continuity of Operations .....	42
4.5 Modernized WCDS Costs, Benefits, Investment Flow, and Funding .....	45
4.5.1 Analysis Principles, Alternatives .....	46
4.5.2 Cost Analysis .....	47
4.5.2.1 Program Cost .....	47
4.5.2.2 Program Cash Flow .....	47
4.5.3 Benefit Analysis .....	48
4.5.4 Funding Requirements, Sources .....	49
5 Current (1995) Water Control Data System Status, Activities .....	51
5.1 Overview - Hardware and Software Development .....	51
5.1.1 Hardware .....	51
5.1.2 Data Acquisition .....	54
5.1.3 Data Storage, Management and Reporting .....	54
5.1.4 Modeling Forecasting, and Simulation .....	55
5.2 Summary .....	55
6 Life Cycle Management of Automated Information Systems (LCMIS) for WCDS .....	57
6.1 Overview of LCMIS Process .....	57
6.2 Life Cycle Phases and Decision Milestones .....	57
6.2.1 Mission Need Justification (Milestone O) .....	57
6.2.2 Concept Exploration and Definition (Milestone I) .....	57
6.2.3 Design, Demonstration, and Validation (Milestone II) .....	58
6.2.4 Development (Milestone III) .....	58
6.2.5 Production and Deployment .....	58
6.2.6 Operations and Support (Milestone IV) .....	58
6.3 WCDS and LCMIS Compliance .....	58

## Table of Contents (continued)

<b>Appendix</b>	<b>Page</b>
A	Glossary of Abbreviations and Acronyms ..... A-1
A.1	Organizational - Institutional ..... A-1
A.2	Data-related ..... A-1
A.3	Software-related ..... A-3
B	Mississippi Basin Forecast Model ..... B-1
B.1	Mississippi Basin Forecast Model. .... B-1
B.2	Areal Extent ..... B-2
B.3	Analytical Procedures. .... B-2
B.4	Input Requirements. .... B-3
B.5	Output Requirements. .... B-4
B.6	Hardware Requirements. .... B-4
C	WCDS Briefing Package, 5 May 1995 IPR ..... C-1

## List of Tables

<b>Table No.</b>	<b>Page</b>
2.1	Corps Water Control Organizations, Staff ..... 9
3.1	circa 1988-1990 Water Control Data System, Computer and Related Hardware ... 15
3.2	circa 1988-1990 Water Control Data System, Remote Date Acquisition, Communications Hardware ..... 15
3.3	circa 1988-1990 Water Control Data System Corps-wide Software ..... 19
3.4	circa 1988-1990 Water control Data System Cumulative Investment, Annual Costs (\$1000's) ..... 21
4.1	Modernized Water Control Data System Program Cost (\$1000's) ..... 47
4.2	Modernized Water Control Data System Cumulative Program Cost (\$1000's) .... 48
4.3	Modernized Water Control Data System Funding Sources (\$1000's) ..... 49
5.1	Modernized Water Control Data System Life Cycle Computer Replacement Status 54

## Table of Contents (continued)

### List of Figures

Figure No.		Page
3.1	WCDS Hardware/Software Time Line .....	14
3.2	Overview, WCDS Software Plan .....	17
3.3	Overview, WCDS Software Implementation .....	18
4.1	Water Control Subnet - Architecture 95 .....	28
4.2	Overview, Modernized WCDS Application Software Plan .....	43
4.3	Overview, Modernized WCDS Application Software Implementation .....	44
5.1	Software Transition for Modernized WCDS .....	52



## Preface

This document is a product of the Real Time Water Control research project of the US Army Corps of Engineers Civil Works Research and Development (R&D) Program. It documents the history, status, and future plans for improving the Water Control Data System (WCDS); the data acquisition, management, modeling and decision support system that serves the Corps water control mission. It is intended to provide a resource for communicating about the WCDS within the Corps and also to outside interested parties. A major use will be to assist in documentation needed for bringing the WCDS into compliance with Corps requirements for Life Cycle Management of Information Systems (LCMIS).

The document is the result of WCDS system modernization planning associated with the real time R&D program, feedback from a series of regional reviews held at a number of Corps field offices in FY 1994, and compilation of information from an April 1995 Corps headquarters data call for information needed for LCMIS compliance documentation. The early documentation reviewed in the field workshops was prepared by Dan Barcellos and Art Pabst, Hydrologic Engineering Center (HEC) staff, working with a group of Corps field office staff. This document was prepared by Darryl Davis, HEC, with assistance from Art and Dan, and Charlie Sullivan and Pete Juhle, Corps headquarters.



# Chapter 1

## Introduction

### 1.1 Purpose and Scope

The purpose of this document is to present relevant historical, present status, and modernization plans for the Water Control Data System (WCDS). It is intended to provide a resource for communicating about the WCDS within the US Army Corps of Engineers and to interested parties outside as well. It is also intended to assist in documentation needed for bringing WCDS into compliance with Life Cycle Management of Information System (LCMIS) requirements. The document describes the Corps water control mission, day-to-day and emergency water control operations, water control management and staff, and role of the WCDS in mission accomplishment. It describes WCDS functions, status, and modernization plans. The WCDS is presented as a snapshot in the circa 1988-1990 time-frame to provide a reference point for the planned modernization followed by a description of plans and activities needed to accomplish system modernization.

### 1.2 Document Structure

This document contains six chapters. Chapter 1 is introductory describing the purpose, scope, and content; Chapter 2 provides an overview of the Corps water control mission, activities, management and staff, and water control data system function and components; Chapter 3 describes the circa 1988-1990 WCDS; Chapter 4 presents WCDS modernization needs, opportunities, and planned activities; Chapter 5 describes the current (1995) WCDS status and activities; and Chapter 6 summarizes the LCMIS process and the steps planned to bring the WCDS into LCMIS compliance. Appendix A is a glossary of abbreviations and acronyms used in the report, Appendix B summarizes the Mississippi Basin Stage Forecast Model project; and Appendix C contains the briefing package for the Water Control Data System IPR of 5 May 1995, the initial step beginning the process of achieving LCMIS compliance. Other appendices may be added as documents are prepared and submitted for LCMIS process compliance.



## Chapter 2

# Water Control Management

### 2.1 Corps Water Control Mission

The US Army Corps of Engineers operates more than 500 dam and reservoir projects constructed under the Army's Civil Works water resources program. The water control mission of the Corps is to regulate river flow with these projects to provide national benefits of flood control, navigation, hydroelectric power generation, water supply, erosion control, environmental enhancement, and other authorized purposes. Authorities to allocate and regulate reservoir storage in projects operated by the Corps are contained in project authorization acts of the US Congress. Water control plans are developed to guide project regulation activities. Activities involved with developing water control plans, gathering and processing data in support of regulation decisions, and regulating the reservoirs in accordance with plans are collectively referred to as 'Water Control Management.' EM 1110-2-3600 *Management of Water Control Systems* and ER 1110-2-240 *Water Control Management* are basic policy and guidance references describing the mission and activities for the Corps water control function. The following paragraph is paraphrased from EM 1110-2-3600.

"Water control management as used herein relates to the hydrologic and hydraulic aspects of completed water resource projects. The activities of water control management include: data collection and handling; determination of project inflow, scheduling releases for flood control, hydropower, water supply, water quality, [navigation, irrigation, recreation] fish and wildlife; coordination of water management decisions; and determination of releases. Water resource projects are "regulated" to meet water control objectives by "operating" spillway gates, sluice gates, pumping plants, etc. In this regard, the "physical operation" of structures, such as the manipulation of gates or recognition of structural constraints, is addressed only in terms of achieving the water control objectives. The term "operation" is used interchangeably throughout this document to mean "regulation for water control" (such as project release scheduling) as well as the "physical operation" of projects. In the same regard, the phrase "project operator" is used interchangeably with "project manager" to refer to the person at the project site who is responsible for the physical operation of the project."

Sections following on definitions of terms and decision processes further clarify the Corps water control mission.

**2.1.1 Definitions.** The following definitions are given for use in the context of water control management. The definitions were chosen to help in a later discussion of the water control decision process and the nature of the WCDS that supports the decision making process.

**Water Management** is the Corps mission to operate Corps projects for authorized

**Water Management** is the Corps mission to operate Corps projects for authorized purposes and in times of flood, manage other projects having a federal flood control interest in accordance with established criteria. This includes long term strategic issues such as: the initial development of operational criteria; periodic update of operational criteria as technology or public needs change; modification to reflect hydrologic modifications and/or increased hydrometeorologic data history; and accommodation of environmental factors, concerns, and constraints. It includes annual and seasonal issues such as: estimation of annual or seasonal water yield; monthly release projections; and real time issues such as daily operation determination; and flood and drought forecasting and event regulation decisions.

**Water Control Plans** are the strategic operational criteria, rules, and procedures that are developed in advance to be used to regulate a project. *Water Control Manuals* contain the results of studies that produce these criteria. Manuals describe the operation of individual projects and the operation of systems of projects. Plans are updated as new data become available, public needs are reconsidered, and legislation and policy change. Water control plans are updated only after studies are performed to evaluate the impacts of proposed changes and the review and approval of the changes have been completed as required. This in most cases requires public meetings and involvement.

**Real Time Water Control** is the application of operational criteria, rules, and procedures (i.e., Water Control Plans) to the specific conditions occurring in a basin at any given point in time. Conditions range from low-flow drought conditions through median-flow normal conditions to high-flow flood conditions all interspersed with a full spectrum of special events and environmental considerations.

**Water Control Data System (WCDS)** is the automated information system (AIS) that supports the Corps of Engineers water control mission including the hardware, software, manpower, and other resources required to acquire, develop, maintain, operate, and manage the system. The WCDS includes the collection, acquisition, retrieval, verification, storage, display, transmission, dissemination, interpretation, and archival of data and information needed to carry out the water control mission of the Corps. Typically this data and information includes hydrologic, meteorologic, water quality, and project data and information. The system automatically collects data continuously from thousands of sensors throughout the nation. In addition, the system gathers and stores spatial satellite and radar imagery, graphical products, text products, and lab and field analyses of chemical, physical and biological samples. The system through its software incorporates this data and information into various user products and system outputs. The WCDS is a nationwide integrated system of hardware and software that allows user access to virtually any data and information in the system. A suite of software gives users the ability to display, manipulate, disseminate, interpret, and transmit this information throughout the Corps and to numerous other interested users.

## 2.2 Water Control Decision Process

The decision process to meet water control objectives is both situational and organizational. Situations, whether they be routine, consequential, or unanticipated, dictate which parts of the Corps organization become involved. References made herein to the interaction between Corps organizational elements are made in a functional or generic sense.

**2.2.1 Strategic Decisions.** Strategic decisions encompass a wide spectrum of activities from the development of master water control plans set down in *Water Control Manuals*, to operational plans based on specific hydrologic, environmental, and economic situations for the coming year, month, day or even hour. These plans consist of criteria and rules governing the operation of water resource projects which are essentially a framework of decisions made in advance to address future hydrologic events.

Operational planning is based on the water control plan. This type of planning is directed to meet specific project purposes and, where possible, choose a strategy that provides the greatest benefit overall. This planning reflects the current hydrologic, reservoir system, environmental, and economic conditions. Factors might include, for example, whether there is a drought or an abundant supply of water; reservoirs are full, empty, in between, or subject to planned maintenance activity; environmental problems are evident; and/or current economic conditions exist which might affect the price and timing of electrical power production. The planning is typically performed within a water management organizational element, typically in an engineering or planning directorate, which includes engineering, hydrology, hydraulics and environmental staff.

**2.2.2 Real Time Decisions.** Decisions made to schedule the immediate operation of project physical features such as control valves, spillway gates, power generation, flow diversion, etc. are considered real time water control decisions. These decisions are made based on the water control plan documented in the *Water Control Manual*, the applicable annual and monthly operational plans, the observed situation as measured and displayed by the WCDS or field personnel observations, the potential future situation as derived from a forecasting process, and the needs and demands of water resource customers. If the situation is routine and well defined by the water control and operational manuals, then technical staff have been delegated by Division or District Engineers to schedule project operation. The technical staff is responsible for coordination among all parties with an interest in the water control operation. This includes coordination within the Corps and with other federal resource agencies such as the U.S. Geological Survey (USGS), National Resources Conservation Service (NRCS), National Weather Service (NWS), U.S. Fish and Wildlife Service (USFWS), U.S. Bureau of Reclamation (USBR), National Biological Survey (NBS), state and local government agencies, and private water resource entities.

In complex situations which are not adequately covered in the water control plan or where a deviation from the plan seems necessary, the water control technical staff coordinate with the professional disciplines in other organizational elements. The participating elements

then provide information and a plan of action to decision makers at the division level for approval. The appropriate decisions having been made, the water control technical staff implement and schedule accordingly.

**2.2.3 Distribution of Operational Information.** The water control technical staff are responsible for distribution of operational information. They gather information about the water resource system, coordinate operations with other operating agencies or customers, coordinate operations within the Corps organization, schedule operations (with decisions made at the appropriate level of delegation), and generally inform all interested parties. Information about the state of the water resource system and the scheduled operations are made available in the WCDS for ad hoc inquiry, by direct routine automated communications, and through routine briefings generally open to the public

**2.2.4 Example Decision Scenarios.** Four decision process scenarios follow. They reflect a range of hydrologic conditions and are intended to generically focus on the decision process and interaction between people rather than provide case study examples. No particular Corps office is used as a model for these scenarios.

**Scenario # 1** In routine flood operations where water flow can be maintained below non-damaging levels, the water control staff monitors available information from the WCDS, field personnel, and other agencies. They perform whatever analysis and forecasting that is required. They consult with other agencies, customers, and Corps staff. As project operations for all project purposes remain routine, they make schedule release decisions at the water control center organization level. Typically in a flood situation there is a time-critical component adding urgency to operational decisions.

**Scenario # 2** In routine low-flow operation where the situation is well defined in *Water Control Manuals* or in other strategic plans such as drought contingency documents, the process of decision making becomes even more collaborative. Generally, low flow situations are recognized well in advance, possibly months before. In these cases, meetings are held with water resource customers and cooperators to plan water deliveries, maintain environmental quality, and where possible meet all authorized project purposes. Adequate time is available to involve all appropriate Corps organizational elements and to provide information and recommendations to decision makers. In some cases where important trade-offs must be made between competing project purposes, the decision process resembles the strategic process for the development of water control and operational plans. Implementation of these decisions by water control staff is typically routine.

**Scenario # 3** In extreme flood situations where water flows have or are forecasted to reach damaging levels, the water control staff is responsible for immediate notification of field personnel, emergency operations staff, cooperating water resource agencies, and all persons on predetermined notification lists. The water control center (reservoir control center) continues to function, but generally in a higher state of alert with possible overtime duty required. Water control decisions are made in the normal fashion, but are additionally coordinated where

necessary with other Corps emergency response activities, such as community flood fighting assistance, emergency repairs, etc. Usually, operational decisions must be made rapidly to react to changes in the flood situation, and the guidance for project operations found in water control plans plays a larger role in the decision process. In these situations, an Emergency Operations Center is usually established independently to deal with the emergency situation. This center is the coordination point for all information relative to the emergency and pertinent to the Corps office response. Water control technical personnel provide information to the Emergency Operations Center.



Sand bagging on major river levee. Photo courtesy California DWR.

**Scenario # 4** In extreme drought situations where water supply is insufficient to meet increases in demand for water from competing project purposes, the decision process requires a strategic approach. If drought contingency plans require severe shortages to customers or severe environmental impacts, then the Corps office typically becomes one of many government and private players in river basin wide planning. Within its legislative authority, the Corps will typically work with regional public and political interests to find consensus on an operating plan. Water control personnel are typically called upon to provide status and forecast information, and to participate with other Corps organizational elements in analyses of alternate operation plans.

## 2.3 Corps Water Control Management Structure, Staff

EM 1110-2-3600, Chapter 8 outlines the Corps organization and staff responsible for water control management. The following paragraphs are quoted (with some revisions) from this chapter:

"a. Organization. The overall responsibility for water control management throughout the Corps is assigned to the Water Control/Quality Section, Hydraulics and Hydrology Branch, Engineering Division, <Civil Works Directorate, HQUSACE - CECW-EH-W>. CECW-EH-W establishes major policy and guidance pertaining to Corps-wide water control management activities. ER 1110-2-240 establishes the authority and responsibility for water control activities within the Division offices. There are currently ten Division offices in the Corps that have functional Water Control Centers. These are Missouri River, North Pacific, Ohio River, Southwestern, North Central, Lower Mississippi Valley, South Pacific, South Atlantic, North Atlantic, and New England Divisions. Although the basic mission and water control objectives of each Division are similar, major differences exist in the types of water control projects and the degree of delegation of responsibilities by Division to the District offices for real-time water management activities. All of the Water Control Centers closely monitor prevailing hydrometeorological and water control conditions throughout their respective Division, and all have staff management responsibility over the Districts, except NED, which is an operational Division office having no districts."

"c. Staffing. The staffs of the Water Control Centers in the Divisions and Water Management Section in the Districts are normally made up of civil (hydraulic) engineers, meteorologists, environmental engineers and hydrologic technicians. In addition, hydrologists, agricultural engineers, biologists, chemists, physical-scientists, computer technicians and mathematicians contribute significantly to water management in several offices. The responsibilities are highly diversified, and much of the work lends itself to computerization, from basic data collection to modeling water resource systems for multiple water control objectives. Most District and Division water control management elements have acquired high-speed computer systems that are dedicated to water control management and retains full responsibility for both the hardware and software."

While the EM is dated almost eight years ago, the organizational structure and staff continue to be essentially as described. The trend to increased computerization as mentioned above continues to this day with responsibility for dedicated water control management hardware and software retained by water control staff. Table 2.1 summarizes Corps water control management organization and staff for the 1988-1990 and current time-frames.

**Table 2.1**  
**Corps Water Control Organizations, Staff**  
**(FTE)**

Offices	circa 1988 - 1990		FY 1995	
	Water Control	Support	Water Control	Support
HQUSACE/ CECW-EH-W	5	0	4	0
Divisions	91	19	86	15
Districts	349	82	337	78
Labs, other	0	4	0	4
Totals	445	105	427	97

## 2.4 Role of Water Control Data System (WCDS)

The WCDS is the hardware, software, and data collection system that support accomplishment of the water control mission. The system serves primarily to support the informational needs for Corps water control decisions made throughout the Corps. There are hundreds of water control decisions made by the Corps each day throughout the nation during normal hydrometeorological conditions. These include, for example, decisions related to reservoir releases, power generation, navigation structure operation, facilities maintenance scheduling, special event operations, and others - the list is quite long. The number and difficulty of these decisions, and consequently the information support needs, vastly increases during flood and other extreme events. Most day-to-day water control decisions are made at the technical staff level in district offices, with oversight and support at division level. In some divisions, the day-to-day real time water management decisions are made at the division level.

Other Corps functions served by information from the WCDS include emergency management; environmental, land, and recreation system management; and the myriad of water-related interests of the Corps. Information is shared with other federal and local agencies to enable efficient, coordinated accomplishment of complementary activities. Local partners, users, and the general public are also users of the information available in the WCDS.

## 2.5 WCDS Functions

Chapter 5 of EM 1110-2-3600 describes the WCDS in detail and its functions. For the purposes of discussion here, the functions are grouped into the following categories: 1) data acquisition; 2) data storage, management, and reporting; and 3) modeling, forecasting, and simulation.

**2.5.1 Data Acquisition.** There are a number of sources and types of data required by water control managers as inputs to the decision process for regulating water resource projects. These data include information on the state of the watershed, project status, forecasts of meteorologic conditions, and operational demands/ constraints. The information is obtained from a variety of data acquisition systems, Corps and non-Corps projects, and cooperating water-agency data systems, both at local and national levels. Primary data sources are GOES satellites, DOMSAT, NWS-AFOS, radar DATACOL sites; secondary sources are flood warning systems (ALERT), land-based radio systems, and water agency data. Approximately 400,000 individual data values are received each day from Corps projects and other gaging sites. These data are screened, stored, and used in modeling and reporting activities.

**2.5.2 Data Storage, Management, and Reporting.** The data acquired to monitor system status, both fixed and time variant, must be managed as a comprehensive data source to support the water control mission. The data to be stored and managed include hydrologic, meteorologic, and water quality data; project descriptions, design parameters, manuals, reports, project documents, geographic information, spatial data displays, maps, satellite images, sound, and video. From these data, reports and displays are generated, information exchanged with others, and modeling input derived to support forecasting and simulation. Model results become part of the data management process to ensure complete capture of system status, forecasts, and consequence of alternative release strategies.

Corps water control data and decisions are exchanged within the local office, with other Corps offices, and water agencies at the federal state, and local levels. Water control technical staff members are responsible for distribution of operational information. They gather information about the water resource system, coordinate operations within the Corps organization and with other operating agencies or customers, schedule operations (with decisions made at the appropriate level of delegation), and generally inform all interested parties. Information about the state of the water resource system and the scheduled operations are made available in the WCDS for ad hoc inquiry, by direct routine automated communications, increasingly via World Wide Web servers that are network accessible, and through routine briefings generally open to the public. After the local responsible office has verified selected data, that data may be transmitted to other (primarily Corps) offices. Disseminated data may also include forecasts or operational decisions, where appropriate. Any associated data-quality parameters are also sent with the data. The data are transmitted in a standard format (e.g., SHEF), where appropriate. Selected offices are able to access the local office's network to view data and information that was not automatically transmitted to them. The National Weather Service has the mission to disseminate meteorologic and river flow and stage information to the public. The Corps cooperates with NWS in accomplishing this dissemination task.

**2.5.3 Modeling, Forecasting, and Simulation.** Reservoir regulation decisions consider present system status, likely future system status and inflows, and impacts of alternative release strategies within the capabilities of the system and authorized purposes. Forecasting models and impact analyses through simulation modeling are the key tools needed to perform such analysis. Timely and reliable storm-runoff and low-flow forecasts are needed for the most effective water

control decision making. Forecasts consider uncertainty in future conditions and thus include probability assessments. Soil moisture conditions and base flow are particularly significant for conditions of low/moderate runoff. Reliable mechanisms for feedback and updating of model parameters are essential, as is the need for initial calibration. Results of flow forecasts are input to hydraulic, reservoir system, and economic and environmental impact analysis to provide a comprehensive view of the consequences of alternative regulation strategies. Water control decision making requires that the forecasts and impact analysis are performed in real time.

## **2.6 WCDS Oversight**

Policy ER's and EM's provide guidance for development and management of the WCDS. Oversight for activities related to WCDS is by Corps headquarters hydraulics and hydrology (office symbol CECW-EH-W) supported by an advisory panel coined the Field Technical Advisory Group (FTAG).

**2.6.1 Field Technical Advisory Group (FTAG).** This group is comprised of senior water control officials at the division level. FTAG is chaired by the Chief, Water Control Section (CECW-EH-W). Meetings are called at such times as major policies are being formulated, implemented, consensus is needed on an issue, or in general when senior level feedback on activities related to water control management is needed.

**2.6.2 Policy Guidance.** WCDS master plans are required in accordance with guidance in ER 1110-2-240 *Water Control Management*. Further technical guidance for WCDS is contained in EM 1110-2-3600 *Management of Water Control Systems*. Master plans are prepared and approved by Headquarters, US Army Corps of Engineers (HQUSACE) for field office WCDS. Revisions to plans are made periodically and approved by HQUSACE. Policies governing WCDS management are contained in ER 1110-2-249, *Management of Water Control Data Systems*. The Corps South Western Division (SWD) prepared a detailed technical document entitled *Water Control Data System Software Manual* as an extension to its master plan. A number of other Corps offices use this manual as a model for their own software development activities.

**2.6.3 Annual Reports.** Divisions are required to submit an annual report on water control management activities within their division. Sections in these reports address water control manuals, monthly summaries of reservoir operations, and water quality. Relevant WCDS activities are likewise included in the annual report. WCDS master plans and annual summaries are submitted each year.



## Chapter 3

### Water Control Data System circa 1988-1990

The circa 1988-1990 system is herein defined as that hardware system and associated software in existence prior to initiation of the presently active life cycle replacement of dedicated water control computer systems. The acquisition of dedicated water control Harris computers began in 1985 and concluded shortly thereafter. Planning for life cycle replacement began in 1989 and replacement commenced in 1992. The circa 1988-1990 system is comprised of the collection of equipment and associated software that evolved over the years from a variety of acquisitions and activities by individual offices with occasional, significant actions undertaken centrally for the benefit of all.

#### 3.1 Background, History, General Functionality

The collection of hardware and software began to take shape as a Corps-wide system in the middle 1980's. Figure 3.1 is a summary diagram depicting the flow of hardware, software, and related events in the time frame 1975 to the present. On the hardware side, notable events include development of WCDS Master Plans, Corps-wide acquisition of the WCDS Harris mini-computers (CEAP-III), and NPD's development (and MRD usage) of the Amdahl based-WCDS computer and associated software. On the software side, notable events include development of the ORD water control system and SWD WCDS Software Manual, development of the Hydrologic Engineering Center (HEC) family of WCDS software products via O&M field funding (and later the Real Time Water Control R&D program), and the creation of the numerical model maintenance program. This program provided a needed funding source for Corps-wide numerical model maintenance, including WCDS software, that ensured consistent support for Corps-wide water control software. On the data side, notable events include GOES deployment, and the development of NEXRAD and its fielding as WSR-88D radar sites.

#### 3.2 Computers and Related Hardware

Water control computer-related hardware equipment in place in 1990 included mini-computers and associated peripherals, typical office automation personal computers, and a supporting array of printers, plotters, and similar devices. Equipment also included remote data acquisition instruments and associated field and office communications equipment.

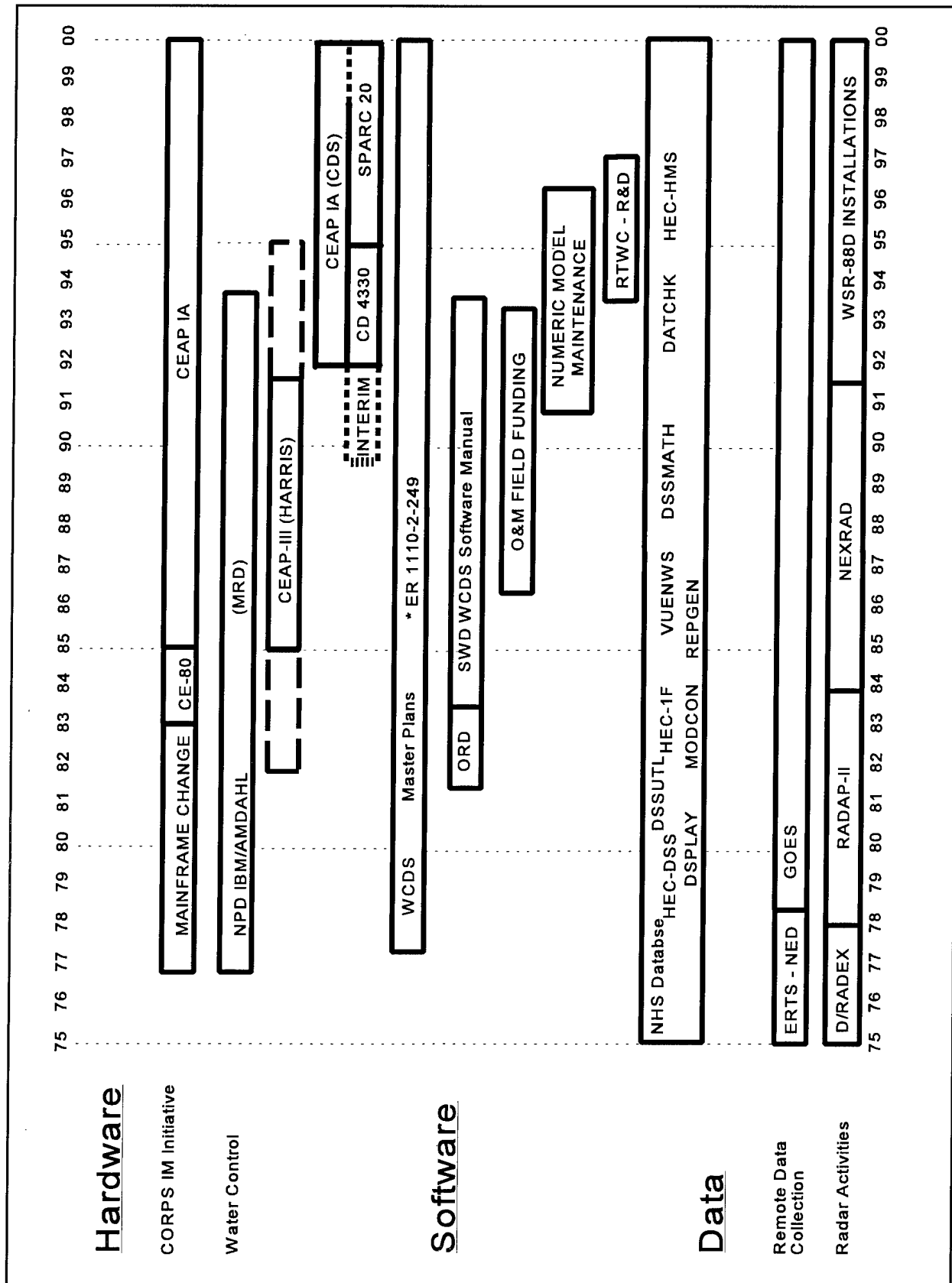

Figure 3.1 WCDS Hardware/Software Time Line

**3.2.1 Computer and Data Acquisition/Communications Hardware.** Table 3.1 presents a summary of computer and related hardware equipment. Table 3.2 presents a summary of remote data acquisition and associated communications equipment.

Typical configurations for the Harris computer systems include a main processor, (H500, H800, H1000), tape and disk drives, high speed line printer, and flat bed or drum plotter. The 'other' computers used in support of water control functions include the NPD Amdahl and occasional leased time from equipment owned by others. Office automation personal computers were typically 386 class machines with 1 to 4 MB memory and 20 to 80 MB hard drives. Typical output was via laser printers and pen and electrostatic plotters.

**Table 3.1**  
**circa 1988-1990 Water Control Data System**  
**Computer and Related Hardware**

<b>Office</b>	<b>Harris Mini</b>	<b>Amdahal (Users)</b>
HQUSACE	0	0
Divisions	2	2
Districts	21	6
Labs/others	1	0
<b>Totals</b>	<b>24</b>	<b>8</b>

**Table 3.2**  
**circa 1988-1990 Water Control Data System**  
**Remote Data Acquisition, Communications Hardware**

<b>Office</b>	<b>GOES</b>		<b>Land Lines (Phone)</b>		<b>Land-based Radio</b>	
	<b>DCP's</b>	<b>Direct/ Ground</b>	<b>Dedicated</b>	<b>Gages</b>	<b>Systems</b>	<b>Gages</b>
HQUSACE						
Divisions	70	6	2	80	0	0
Districts	2,431	5	20	520	19	371
Labs/others						
<b>Totals</b>	<b>2,501</b>	<b>11</b>	<b>22</b>	<b>600</b>	<b>19</b>	<b>371</b>

**3.2.2 Computer Life Cycle Replacement.** The Harris computers acquisition began in 1981 and by 1986 equipment was essentially in place. Life cycle replacement planning began in 1989. Because of delays in selection of new system hardware, interim replacement hardware was approved for use until a final selection was made in March 1992. These activities were formulated and monitored by a task group with oversight from CECW-EH-W. Subsequent life cycle replacement requirements are described in Chapter 4, Water Control Data System Modernization Project (post circa 1988-1990), and current status in Chapter 5, Current (1995) Water Control Data System Status, Activities.

### **3.3 WCDS Software**

Software was developed to address various aspects of the basic WCDS functions of system status monitoring and data acquisition; data storage management and processing; modeling and simulation; and information exchange. A portion of the software was developed for Corps-wide usage but substantial development took place in local water control offices.

**3.3.1 Software Overview, Origin.** The Corps-wide software was developed by the Hydrologic Engineering Center mostly as reimbursable products for a specific field office. The software was subsequently generalized with modest R&D support for Corps-wide application. The field office locally developed software was designed to meet local, site-specific needs. The software was developed as an ongoing activity by district and division water control staff. Figure 3.2 Overview, WCDS Software Plan, originally published in the Corp South Western Division's Water Control Data System Software Manual, dated February 1983, was later published in EM 1110-2-3600 as an example schematic of WCDS software. Corps water control offices implemented the example schematic to varying degrees. Figure 3.3 is a companion schematic to Figure 3.2 showing computer programs developed and supported for Corps-wide use by HEC. Most Corps implementations of the suite of software made use of the HEC-DSS (Hydrologic Engineering Center Data Storage System) as the central data manager. A few offices either created their own data management system or used commercial software.

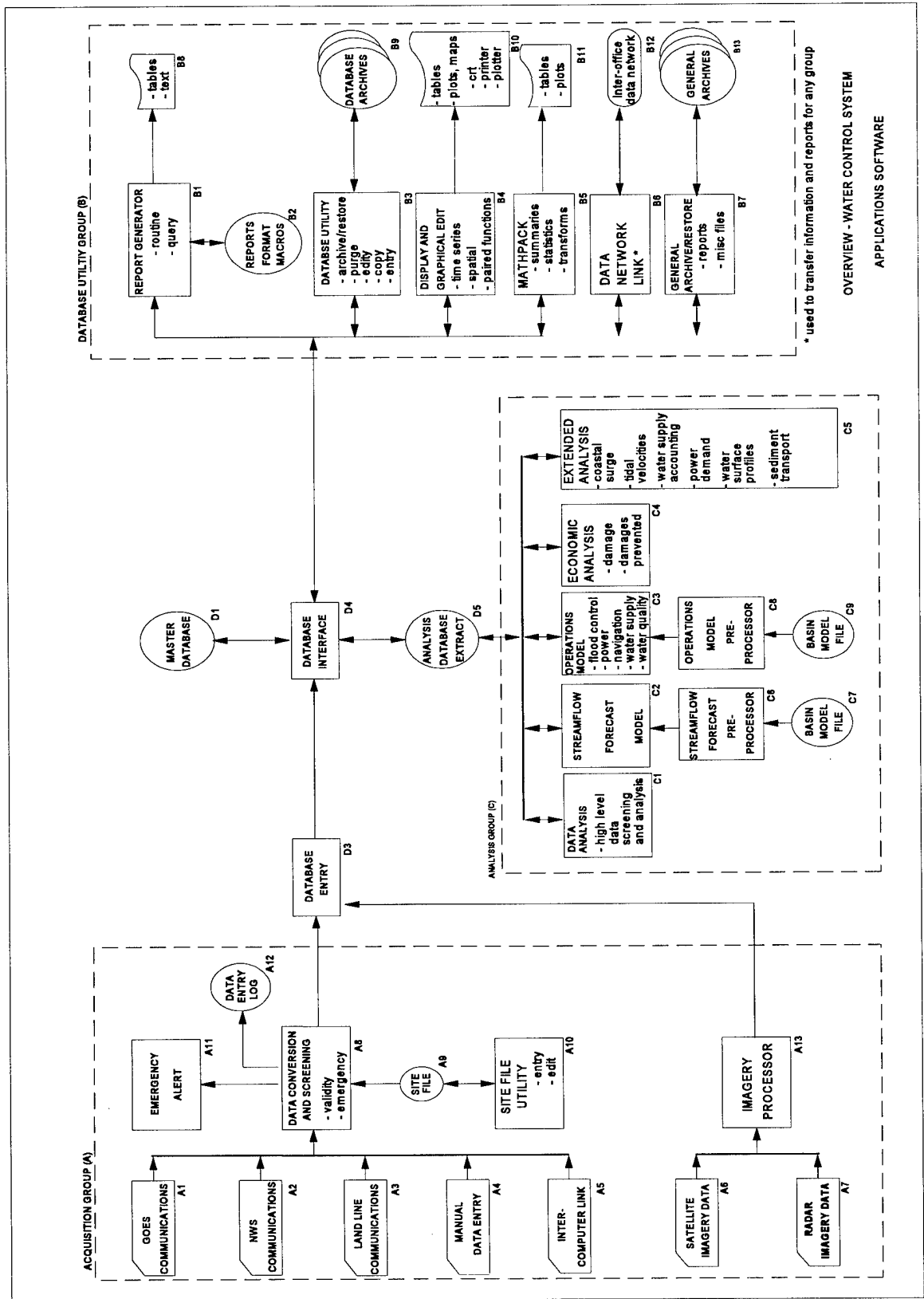

Figure 3.2 Overview, WCDS Software Plan

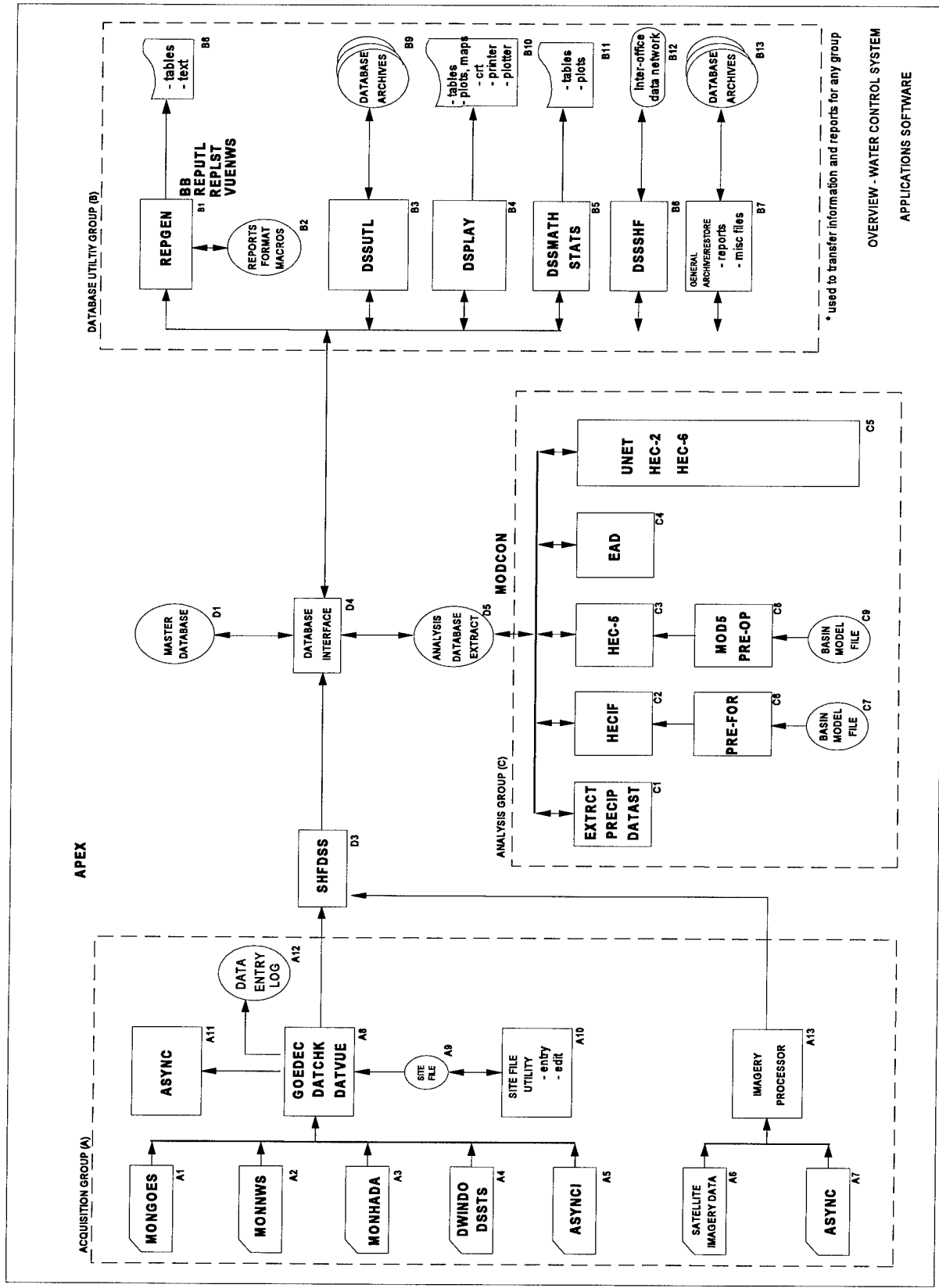

Figure 3.3 Overview, WCDS Software Implementation

**3.3.2 Software Characteristics.** Table 3.3 summarizes characteristics of the software comprising the circa 1988-1990 WCDS.

**Table 3.3**  
**circa 1988-1990 Water Control Data System**  
**Corps-wide Software**

<b>Function</b>	<b>Programs</b>	<b>Lines of Code</b>	<b>Language</b>	<b>Comments</b>
Data Acquisition	13	80,000	Fortran, C	async communications, scheduling, user interface
Data Storage, Man-agement, Reporting	26	160,000	Fortran	HEC-DSS system, bulletin boards, graphic displays
Modeling, Fore-casting, Simulation	14	360,000	Fortran	PRECIP, HEC-1F, HEC-5, HEC-5Q, UNET, HEC-2
Totals	54	600,000		

Locally developed software is comprised of adaptations of Corps-wide software, small and large, region specific analysis and communications packages, and script files that automate execution of Corps-wide and locally developed software. Because much field office pre-existing software was ported to the Harris computers, the total sum of such software likely exceeds Corps-wide software. The coding language for most locally developed software was Fortran. Office automation commercial software used in conjunction with the WCDS include word processing, spreadsheet, and plotting packages. Also implemented were two instances of commercial data base systems, IDBMS - an IBM system, in the case of the NPD Columbia River Operational Hydromet System (CROHMS) and TOTAL (a CDC system) in the case of SWD. Major field office developed software include the Streamflow Synthesis and Reservoir Regulation (SSARR) model developed by NPD, reservoir system model (SUPER) developed by SWD, and the ORD developed unsteady flow model FLOWSED.

### **3.4 WCDS Hardware and Software Maintenance and Support**

Maintenance and support for WCDS hardware and software is provided primarily by water control staff, but important contributions are made by others.

**3.4.1 Hardware Service and Support.** The dedicated Harris water control computers and associated peripheral equipment are managed by water control staff in districts and divisions.

Service and support is likewise provided by these staff. Management and service of this equipment is considered a normal part of water control staff activities. The Corps data collection from hydro-meteorological gaging stations involved over 5,000 stations. The cost for support of these stations was \$18.5 million in 1990 and in 1994 it is \$19.5 million.

**3.4.2 Corps-wide Software.** Corps-wide water control software was developed by and is serviced and supported by the Hydrologic Engineering Center. To facilitate software support, HEC acquired a water control Harris 1000. Acquisition and service of the Harris computer system was via normal HEC in-house resources. Software support provided by HEC staff is funded under the Corps numerical model maintenance program. WCDS software support is a portion of the overall model maintenance program. This funding has none-the-less been an important means to ensure timely service for WCDS software. The numerical model maintenance program was a bill-back funded activity created to fund Corps offices, mostly R&D labs, HEC, and the Institute for Water Resources (IWR), in providing field office support for software in the following categories: software maintenance, documentation updates, consultations, and minor corrections. The program, managed by CERD, began in 1989 and continues to the present. Bill-back funding will cease in FY 1995. Transition funding from the central account is planned for FY 1996 with a user pay system to be devised for FY 1997 and subsequent years.

**3.4.3 Locally Developed Software.** As mentioned previously, substantial software was developed by district and division water control staff to meet their needs. The maintenance and support of such software is by local water control staff funded out of local water control budgets.

### **3.5 circa 1988-1990 WCDS System Cost**

Although guided by Corps-wide policy, the circa 1988-1990 system WCDS was not a centrally planned and developed system. As such, historical tracking of investment and annual operation and maintenance costs in detail was not done. None-the-less, an attempt is made herein to estimate these costs based on known information and reasonable assumptions. Investment, operation, maintenance and support cost items include: computer and related hardware, remote data acquisition, communications and related equipment, Corps-wide software, and locally developed software. Table 3.4 summarizes circa 1988-1990 WCDS investment, operation, and maintenance cost.

**Table 3.4**  
**circa 1988-1990 Water Control Data System**  
**Cumulative Investment, Annual Costs**  
**(\$1,000's)**

<b>Item</b>	<b>Cumulative Investment</b>	<b>Annual Operations, Maintenance and Support</b>
Computer and Related Hardware	16,000	19,400
Data Acquisition, Communications	52,000	18,600
Corps-wide Software	3,500	400
Locally Developed Software	7,500	1,000
<b>Totals</b>	<b>79,000</b>	<b>39,400</b>



## Chapter 4

# Water Control Data System Modernization Project (post circa 1988-1990)

### 4.1 Overview

The WCDS modernization project includes replacement of pre-1990 computer and related hardware; upgrades to field instrumentation and communications equipment; and upgrading existing WCDS software including porting existing products, modifying and upgrading existing products, and development of new software products. Incorporated within the project are both centrally developed and maintained software and field developed software. Modernizing WCDS will standardize equipment, data handling, and software and thus ensure maintainability, upgradability, and usability. The project integrates activities among HQUSACE elements, R&D projects, and field development and implementation efforts. The WCDS modernization project is actively undergoing efforts to bring it into compliance with the LCMIS process.

### 4.2 Needs/Opportunities

**4.2.1 Needs.** The circa 1988-1990 WCDS computer equipment was aged and data acquisition and processing requirements are increased beyond capacity; operation and maintenance was costly; and staff requirements to continue useful service was excessive. The water control decision process continues to increase in complexity and involve more interested parties. This in turn increases the need for improved responsiveness in information acquisition, processing, display, and communications/exchange. Recent extreme events, such as the Great Mississippi flood of 1993, have taxed the limits of WCDS and exposed the need for improved capabilities. At the same time, substantial advances in computer and related hardware, and companion modern software, provide the opportunity to substantially improve execution of the water control mission. Benefits of system modernization will include both cost reduction and performance improvements. Subsequent sections will further describe and quantify the needs, opportunities, requirements, scope of modernization activities, and costs and benefits.

**4.2.2 New Network and Workstation Technology.** RISC powered UNIX workstations have processing capability orders of magnitude greater than the Harris minicomputers at a fraction of the cost. Likewise, communications and network hardware and software technologies are continuing to rapidly advance. The Corps CEAP contract, and subsequent technology upgrade insertions, provide procurement access to workstation equipment. Network technology is rapidly becoming common place within Corps offices and other cooperating federal and local government agencies. CEAP provides backbone network communications technology within the Corps and provides the gateway to other networks via Internet. Integrated with appropriate software, this technology provides the potential for increased access to data sources, improved processing power for flow forecasting and impact analysis through modeling, and increased effectiveness in exchange of information within the Corps and among cooperating partners.

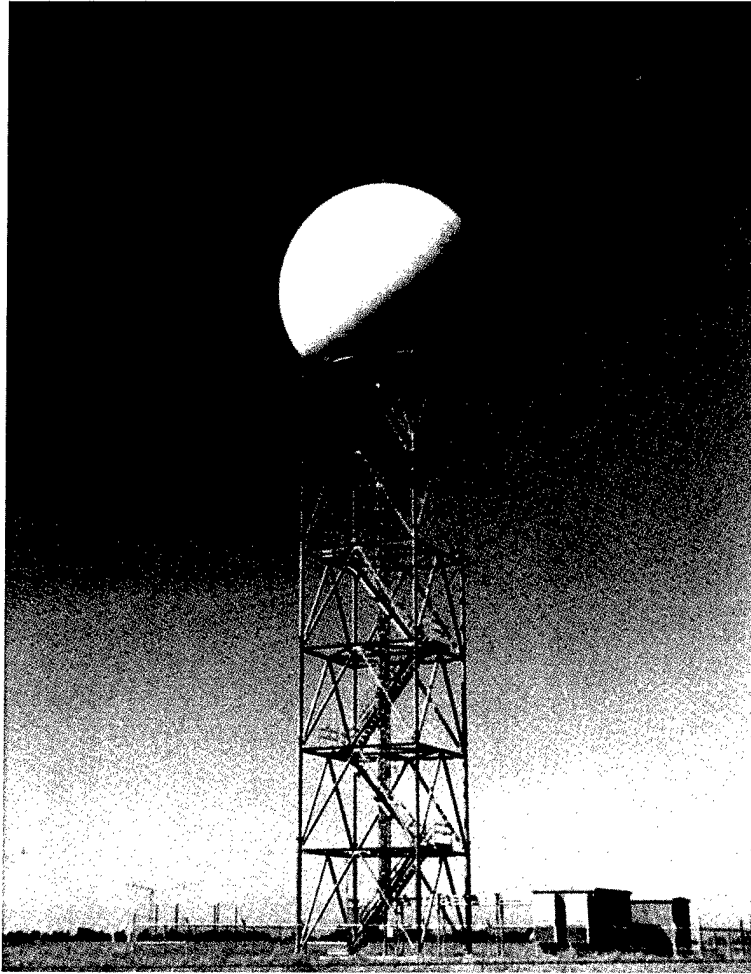

NWS Weather radar (NEXRAD) near Davis, CA. HEC photo.

**4.2.3 New Data Sources.** Important new data sources for input to real time regulation decisions either are now available, or will be within the near term. Geographic Information Systems (GIS) are commonly employed by the Corps and other state and local agencies to manage land-based and other geospatial data. Satellite imagery, and other space craft remote sensing data, are now routinely downloaded and displayed for scientific as well as general public information. Analysis methods to make use of such data in hydrologic modeling and forecasting continue to be developed in Federal government research laboratories, universities, and the private sector. Integrated with ground-based radar sensor data, in-situ measurements, and data handling and processing systems, these capabilities offers the potential for an important advance in information support to the Corps real time water control mission. This is particularly the situation with the National Weather Service NEXRAD technology now being installed throughout the U.S. This technology, when integrated with the WCDS, provides greatly improved quantification of the spatial distribution of precipitation during the occurrence of the event, thus enabling greatly increased accuracy in forecasting flood runoff in a timely manner. The key to effective utilization of these new data technologies is their integration within the WCDS.

**4.2.4 Improved Data Management Technology.** Software for storing, retrieving, manipulating, and displaying a wide range of data has improved markedly over that of the last decade. The opportunity exists to develop a corporate Corps-wide water control data base system that would serve real time as well as other water management information needs. Software that can provide the kernel for the system is available under the CEAP contract. Integration of data, models, and information management via the corporate data base would provide an improvement in overall data handling within the WCDS.

**4.2.5 New Modeling, Forecasting and Simulation Tools.** Advances in software that will take advantage of new and improved data sources and analytical analysis methods, implemented within state-of-the art computer processing and network systems, would provide the critical element in improved information for water control decisions. Software to incorporate spatial precipitation data available from NEXRAD for forecasting, optimization algorithms for reservoir regulation, economic/flood damage impacts, and environmental effects are examples of advanced software that promise significant contributions.

### **4.3 Software Engineering**

**4.3.1 Overview.** Software engineering refers to the overall process by which user needs are determined, software is planned, and designed, coded, tested, and maintained. This section describes the WCDS software engineering process and issues involved. The software that will be developed and maintained following the software engineering principles described herein includes all features of the modernized WCDS.

**4.3.2 User Requirements.** WCDS software user requirements are the result of several activities: study of the circa 1988-1990 WCDS implementation throughout the Corps, results of field workshop sessions held during FY 1994, results of deliberations of the field review groups for each of the relevant R&D programs, statutory requirements, HQUSACE guidance, and continuing feedback from WCDS system users in training sessions, technical assistance projects, and workshops. Determining user requirements is an ongoing process as components of the system are developed and fielded. Documentation of the requirements exists in various forms: R&D work unit documentation, working session notes and memoranda, individual project scope statements, and other. They are periodically compiled for reporting purposes, which will subsequently be formatted to meet LCMIS documentation needs as the modernization project progresses. User requirements for the modernized WCDS are summarized in Section 4.4.

**4.3.3 Software Design.** Design is undertaken at several levels. Preliminary requirements and overall functional design are performed within a group/design team setting. When appropriate, prototyping is performed to provide a vehicle for further user interaction and feedback. When existing software addresses some of the user requirements, the new user requirements are compared with existing capabilities and the potential for upgrade evaluated. The decision between upgrade of an existing software component and new development is based on complete life cycle analysis. The analysis considers functionality, scheduling, development/

upgrade costs, and maintenance and operation costs. The relationship of the specific software component under study to other WCDS system software is also an issue that is considered. Upgrade/new development then proceeds to more detailed program design that includes developing program architecture, data flow, data dictionaries, and coding language pseudo-code. The detailed code design may involve a team of software design specialists if program scope and complexity so warrant, or may be constructed in the design some-build some, design some-build some, etc., process performed by a single individual. In most practical software development projects such as WCDS, design is a progressive, iterative process that is not completed until the software development is completed so that final software design is ultimately represented by the completed program code. Object-oriented design is being employed for those software components that can benefit from such architecture.

**4.3.4 Coding Languages and Coding.** The circa 1988-1990 WCDS code is Fortran. The code is several vintages of Fortran (e.g., Fortran IV, Fortran 66, Fortran 77). New coding will be in the language most suitable for the specific software component. The modernized WCDS will include ported code from the circa 1988-1990 WCDS (mostly Fortran 77), Commercial Off The Shelf (COTS) software, and new code. Because WCDS shares software and exchanges data with numerous parties outside the Corps, it is expected that the new code will be written in Fortran 90, C, and C++. Script will be used for data base operations (standard SQL query script), GIS procedures (commercial package scripting language), and UNIX C shell scripts for automating software operations and executions. Code will be written primarily by in-house staff in Corps research performing elements and field offices, supplemented by code development procured through contracts. Code standards will be adopted to guide code development.

## **4.4 Hardware and Software Requirements**

Hardware requirements are presented as a summary of the life cycle replacement studies began in 1989 and commentary on field instrumentation and communications needs. Software requirements are presented in the broad categories of data acquisition; data storage, management, and reporting ; and modeling, forecasting, and simulation. A summary of the proposed modernized WCDS software system is presented in Section 4.4.5 .

### **4.4.1 Hardware Requirements**

**4.4.1.1 Computer Life Cycle Replacement.** In 1989, an evaluation of available computers to replace the existing water control computers (Harris mini-computers) was undertaken. A contract was let to evaluate the alternatives. The study results showed that UNIX workstations were the most viable alternative. CD-4330's available via the CEAP-IA contract were found to be the most cost-effective. An economic analysis report was prepared for the life cycle replacement of the Harris water control computer system and presented to the Information Management Resource Steering Committee (IMRSC) for approval. The committee approved the report and a request was sent to the Director, US Army Information System Selection and Acquisition Activity for approval to use CEAP-IA to support water control management.

Approval to use the CEAP-IA contract was received on 6 March 1992. Procurement of CD 4330's was then initiated. In FY 1994, the CD 4330 was replaced on the CEAP-IA contract with the SUN SPARC 20. The purchase of SUN workstations is now ongoing. During the period 1989 to 1992, interim computer equipment was acquired by a few water control sites. The equipment consisted of Intergraph workstations (procured under the Corps CADD contract), a few other UNIX workstations of various manufactures, and SCO UNIX equipped high-end personal computers. The interim equipment is now being phased-out and replaced by the SUN SPARC workstations. Some data capture for WCDS continue to use high-end PC's running SCO or other UNIX software for redundancy and economy.

The Corps Architecture 95 plan includes the water control WCDS as a subsystem of workstation based computers. Figure 4.1 adapted from that document displays the concept of the target system.

**4.4.1.2 Field Instruments, Acquisition, Communications Hardware.** Replacement and upgrade of field instrumentation and communications hardware is an ongoing activity performed in cooperation with other federal, state, and local government agencies. Typical activities include replacement of precipitation, streamgage, and other hydromet and water quality instrumentation and communications hardware as existing equipment becomes obsolete and new technology becomes available. Sensor instrumentation includes float wells, tipping bucket gages, pressure transducers, acoustic flow velocity meters, and thermistors. Recording instrumentation includes strip chart and digital punch tape recorders. Communications hardware automates data retrieval and transmission from sensor equipment and includes land based radio data collection/ transmission electronics, radio/microwave repeaters, satellite data collection platforms (DCP's), telephone data collection/transmission electronics, etc. Various types of environmental shelters and site preparation sometimes are required during replacement. Such replacements (and routine operation and maintenance) that involve a transfer of funds between agencies are managed as part of the Cooperative Stream Gaging program. Replacements of all such equipment, which is Corps property, are further managed through the annual WCDS Master Plan process.

Equipment for retrieving remotely sensed data from satellites and other platforms continues to improve. The Corps makes critical use of analyzed data from radio magnetic spectrum sensors or cameras on board various satellites and air craft to view environmental effects on the earth's surface such as snow cover area, vegetative cover, and flooded areas. The equipment used to receive or view this information is likewise upgraded on a systematic basis.

Hardware equipment to directly access new radars, such as NEXRAD (WSR-88D - Weather Surveillance Radar 1988 Doppler) is required. This equipment includes Principle User Processor Interactive Emulators (PUPIE's), network connection and telephone lines to radar sites, and data communications. Further discussion of equipment requirements in support of data acquisition is contained in that section below.

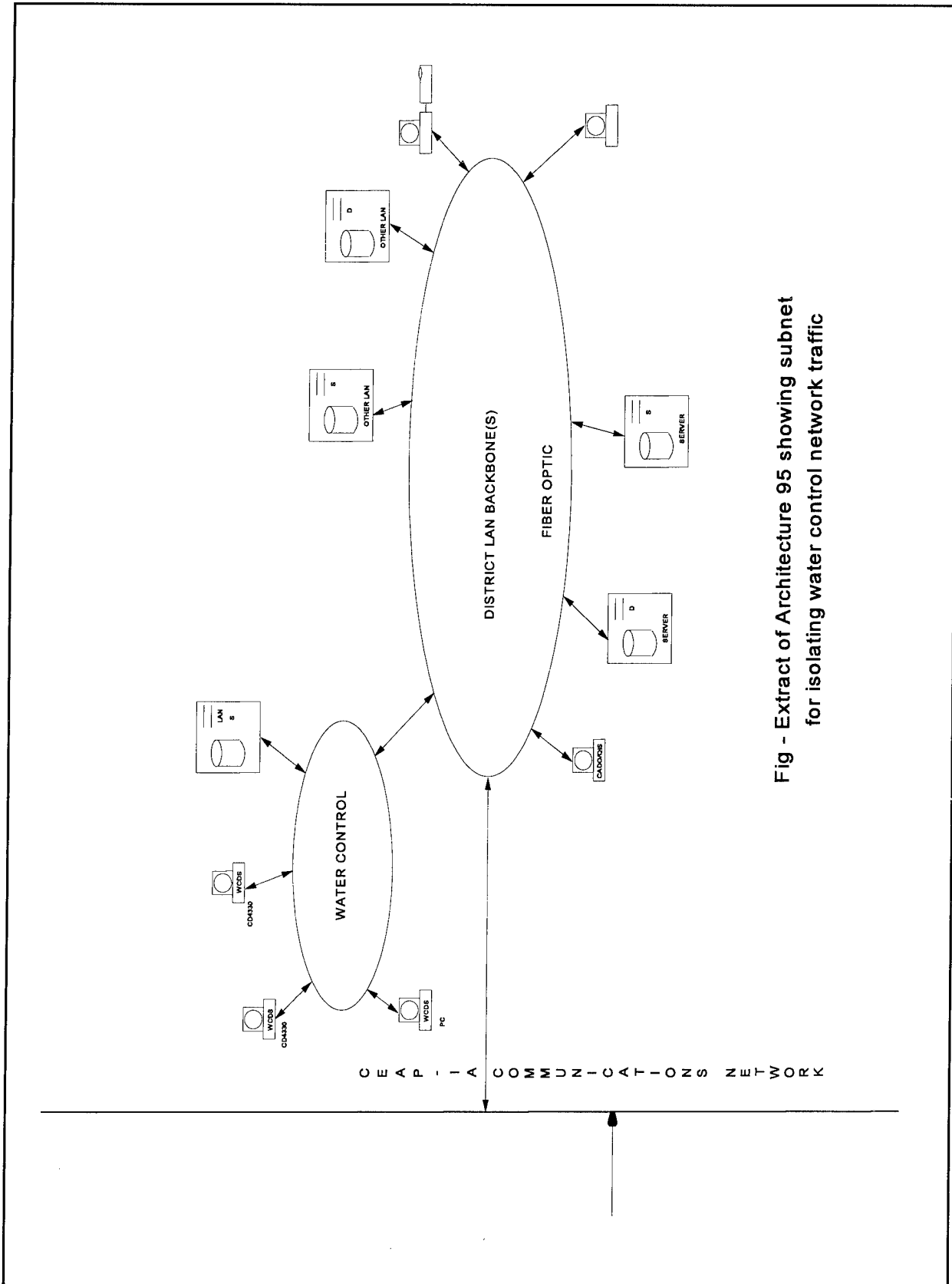

Fig - Extract of Architecture 95 showing subnet for isolating water control network traffic

Figure 4.1 Water Control Subnet - Architecture 95

**4.4.2 Data Acquisition.** There are a number of sources and types of data required by water control managers as inputs to the decision process for regulating water resource projects . The nature of these data range from simple text to complex graphics to audio/video. The software system must be designed to accept, store, and communicate these various data types. Data will be received from diverse sources. These include satellite transmissions via GOES and DROT, NWS data/products similar to those currently available via AFOS or DATACOL, NEXRAD data and products, satellite imagery, line of sight radio and microwave, remote locations via land-line (modems), manual input, and other national and regional sources such as ALERT, IFLOWS, SNOTEL, and Mesonet systems.

**4.4.2.1 GOES.** For the Corps, DCP data via GOES will be the primary source of hydromet data. GOES data can be received numerous ways including by Corps-owned and operated GOES downlink, use of the NESDIS DAPS system at Wallops Island, VA via dial-up telephone lines, and DROT's.

Satellite data collection platforms (DCP's) are a primary data source throughout the Corps. Effort is needed to improve upon the timeliness and availability of DCP data. Proposed alternatives include higher DCP transmission rates, reconfiguration of DCP transmission time windows to permit more frequent but shorter messages, and more and better use of the random reporting capabilities. In some instances, data every four hours is adequate, but in others, hourly data is not sufficient. The system needs to be configured to accommodate a wide range of data timeliness and availability requirements.

Reliability is a critical component of a water control system. Reliability is increased by providing redundant sources for acquiring, storing, and processing DCP data. It is proposed that each office with water control responsibilities acquire a DROT as its primary source of DCP data. To provide an alternate source, consideration should be given to a single, national site established as an online backup that would provide the identical data collection capability afforded by the local DROT. The proposed national site would be an independent GOES downlink to protect against failure of the DOMSAT system or the receive site at Wallops Island. Data available from the national site would be available via the CEAP network and should be virtually the same as the local source in terms of availability and timeliness. As data from adjacent districts may be valuable, the national site could maintain an index of all DCP's by location name, latitude/longitude, sensors, and decoding information so that any Corps site can utilize available data. In the event of a DROT or multiple system failure, dial-up capability to the NESDIS DAPS system would be retained as a third source for DCP data.

**4.4.2.2 National Weather Service Data.** The National Weather Service (NWS) is a primary source for hydrometeorological data, weather and river forecasts, and other information critical to the water control management mission at most locations. The current NWS system for providing required river and weather data is AFOS. A variety of methods are currently used to communicate with the NWS AFOS including direct lines, dedicated telephone lines, and dial-up access, usually to a River Forecast Center (RFC). The NWS modernization program is developing AWIPS as a replacement for AFOS.

It is planned for the Corps and NWS-RFC's to have direct network interconnections. Consideration should be given to establishing a national site that would be capable of providing all desired NWS products to any Corps office. In the event that individual RFC's produce local or internal products that are not distributed nationally, they may be made available to the local Corps office. The use of the CEAP network will make the need for local connections between the Corps and NWS obsolete as there would be no distinction between a local or national source. Dial-up capability to the local RFC must be retained in the event of network accessibility problems.

**4.4.2.3 NEXRAD.** Next generation radar (NEXRAD) is becoming a reality. The transition from the old conventional radar sites to the new Doppler NEXRAD sites is progressing rapidly. Access to these new high quality radar sites will greatly improve quality of the Corps water control performance. These new radar sites provide the Corps with graphical and digital products never before available. Products such as precipitation reflectivity and digital products such as accumulated precipitation estimates can be inserted quickly into forecast models greatly enhancing the Corps ability to estimate the volume and magnitude of runoff from storm events. This information can in turn be plugged into operational models that will assist the water manager in making operational decisions at Corps and Corps managed projects.

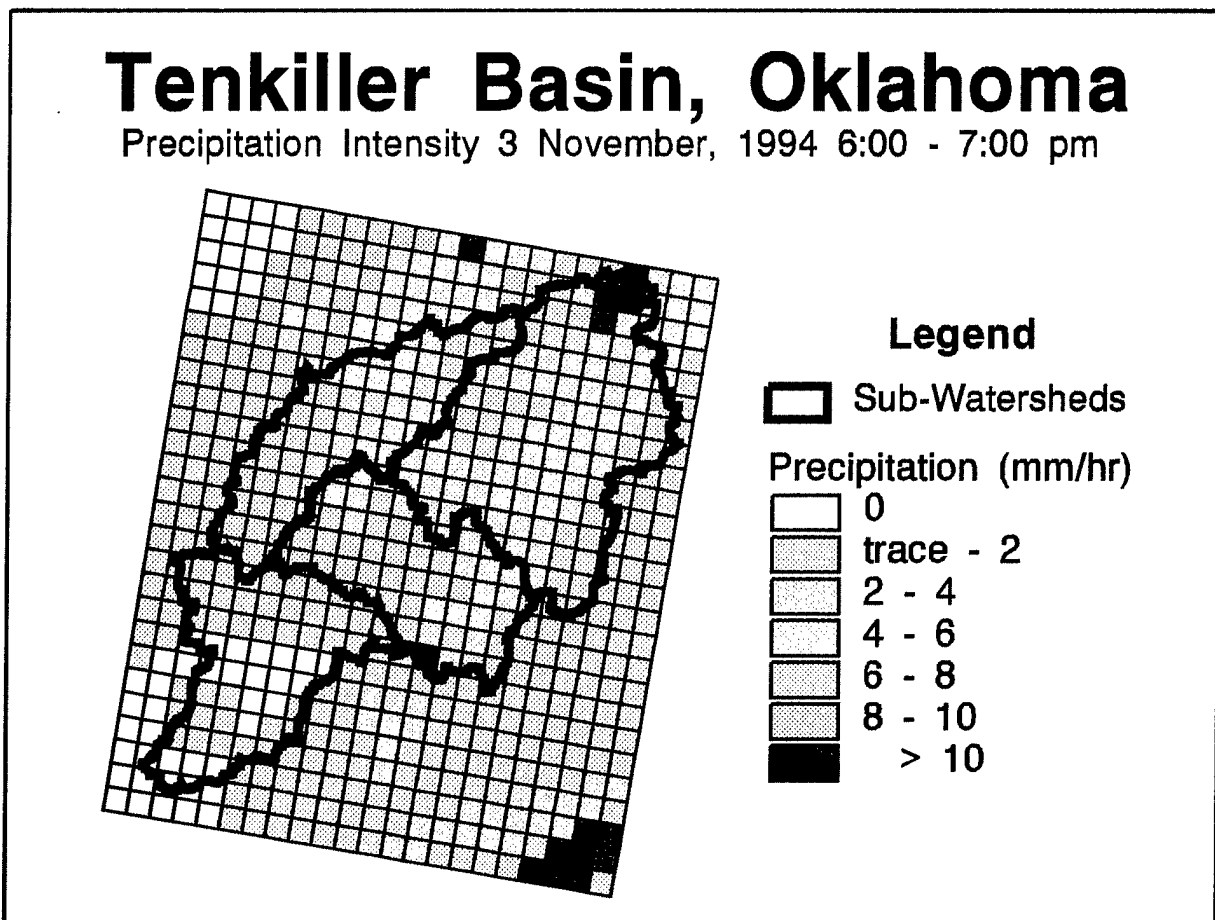

NEXRAD spatial precipitation superimposed on Tenkiller Basin, Oklahoma.

NEXRAD products are becoming available to the Corps via dial-up lines directly from radar sites. However there are logistical problems related to the use and access of NEXRAD sites that need to be addressed. Each NEXRAD site has a single port available for Corps use. Access to the site can only be accomplished with a PUPIE (Principle User Processor Interactive Emulator). The PUPIE is the communications device that makes it possible to access and receive NEXRAD products directly from the radar site. Where multiple districts and divisions need information from a common radar site, access clashes will be a problem. To accommodate multiple users, control the costs associated with the potential proliferation of PUPIE's and preclude access clashes, an organized approach to NEXRAD access and data distribution is required. These problems are being addressed by developing a network of nine corps offices that will access the NEXRAD sites in their area. These nine offices will have the responsibility of collecting and storing and making the NEXRAD products available from the radars in their region. Any Corps office can then access the collection centers for the radar products they desire. Specific tools and techniques and protocols for access storage and distribution of the NEXRAD products must be developed to assure reliable and timely access to the NEXRAD products for all Corps offices. Also, the large amounts of storage needed to accommodate NEXRAD digital products requires that guidelines for storage of NEXRAD products be developed.

**4.4.2.4 Imagery.** GOES images, SPOT or other orbiting satellite images, aerial photography, and other such images are frequently useful or necessary for water control decision makers. Some satellite image data are available from third party vendors by subscription. The Cold Regions Engineering Research Lab (CECRL) has expertise in the acquisition, display, processing, and interpretation of satellite images. Consideration should be given to assigning CECRL as the source and repository for satellite or aerial images for retrieval by water control offices as required. This should reduce redundant acquisition of many images and provide access to sites where costs may have prevented access to this information in the past.

**4.4.2.5 Other Data Sources.** There are many other critical data sources required by Corps offices for water control purposes. Data communications will be via computer network, line-of-site radio, microwave, dial-up (modems), and voice telephone and radio. A number of regional and national data networks exist including ALERT, IFLOWS, SNOTEL, and Mesonet systems. Data are also exchanged with other water resource agencies including the NWS, USGS, flood warning groups, power administrations, and river basin commissions. The ability to acquire and exchange data with these and other sources must be accommodated.

**4.4.2.6 Decoding.** Most data received from remote locations will require further processing to be converted into a common format that can subsequently be loaded into a database. There are currently many diverse formats in which incoming data might be transmitted. For example, there are several DCP manufacturers and each manufacturer has a different format for DCP messages. While a standard DCP format has been discussed and may be desirable, there must be great flexibility in decoding software to accommodate the different data formats that currently exist and may exist in the future. Decoding capability will accommodate the Standard Hydrological Exchange Format (SHEF) for data received from other

agencies. The decoding process must occur in real-time, as distinguished from batch processing, to improve the timeliness and availability of data.

It is recognized that this is shared data and it should be the local office's responsibility for the decoding, transformation, screening, and editing/correcting of its data. This will eliminate the need to maintain duplicate decoding formats, ratings, and editing requirements and provide consistent data throughout the system.

**4.4.2.7 Transformation.** This process involves routine conversion of raw sensor data to other meaningful information, generally involving table look-ups, unit conversions, and generation of other derived data. Examples are stage to flow, elevation to storage, gate setting to flow, inflow computations, and cumulative to incremental precipitation. When feasible, data transformations should occur in real-time as the data are received.

**4.4.2.8 Validation.** Validation is the process of verifying data to reduce the likelihood that erroneous data are written to the database or used in the water control decision making process. Data screening is envisioned as a three part process and is integral to the data capture, decoding, and transformation process. This process will, to a large part, be automated, to the extent that criteria can be developed by which to judge the data. The first-step screening process should occur as data arrives, immediately after the decoding step. An initial screening with criteria related to absolute magnitudes, rates of change, negative increments (precipitation), and other criteria would be done. Data passing the initial screening will be passed on to the transformation process and loaded into the database. The second screening would be based on criteria determined from comparisons with data from related sites, such as an upstream or downstream stream gage or a group of nearby rain gages. Data passing these criteria remain in the database; data failing any of these criteria are flagged as bad and are set aside for manual screening.

Data failing either of the described screening processes must undergo a third screening. This final screening will be performed manually to determine the final disposition of the data not passing the automated screening process. Data would be accepted, edited (graphically where appropriate), or discarded as appropriate. Discarded data should be logged so that repairs to appropriate equipment, software, or procedures can be initiated.

As Corps rain gage sites are expected to be used to calibrate NEXRAD precipitation accumulation products, it is important to know the accuracy and reliability of precipitation gage records. Criteria need to be developed to grade gage records and help determine which sites provide accurate and reliable data for NEXRAD calibration.

As part of the data screening and validation process, or in addition to it, should be the reporting of alarm conditions. The alarms should indicate a situation that requires the attention of water control personnel. For each appropriate sensor or parameter, alarm criteria should be developed. Raw or transformed data passing all automated screening criteria would be compared against the alarm criteria and alarms generated as necessary. Alarm capabilities may also be appropriate with other aspects of the water control system.

### **4.4.3 Data Storage, Management, and Reporting.**

#### **4.4.3.1 Data Types and Availability.** Types of data used by water control include:

Time-series - These includes gage precipitation measurements, river stage and flow values, and many others; Spatial time-series - This includes radar precipitation estimates, satellite weather images and other remotely-sensed data; Basin characteristics and model parameters - This includes subbasin delineations, and transform and routing parameter data; X-Y Data - This includes rating tables, river cross sections and stage-damage functions; Geographic - This includes a variety of information necessary for determining alternative impacts, such as topographical maps, channel boundaries, and flood insurance maps. This data may be stored in a Geographic Information System (GIS); Physical System Information - This includes a list of gages, projects, (e.g., their locations, names, and other pertinent information), etc.; Documents - This includes reservoir regulation manuals, design documents, as-builts and inspections reports; Multimedia - This includes images, photos, film clips, etc., of pertinent projects, river flow, etc.; Calling lists - This includes the names and phone numbers of those to call during decision making; Logs - This includes data logs generated by models; memos, notes, operational decisions, etc., by the Water Control Manager. Data must be readily accessible to the water control manager and others. All of this data should be stored on-line (including documents), and be accessible from remote sites. Primary data should be duplicated on a remote machine to facilitate continuity of operations. Viewing of the data from within primary water control windows/programs should be facilitated.

**4.4.3.2 Database System.** A data base technology is required that will accommodate the identified data types, provide the necessary information in a timely manner, be responsive in emergencies and time critical situations, provide an intuitive user interface for general inquiries, be accessible and useful with other computer applications requiring data and information, and be easily maintained and updated. Data should be directly accessible to and between programs. For example, it should be easy to import or export time-series or parameter data to and from a spreadsheet. Modified data should have a time/date stamp for when the change was made, and an identifier of who modified it. This information is typically stored in a log file associated with the data. The technology should use Standard Query Language (SQL) to access and manipulate system data. Data base technology available through CEAP (Oracle), and existing Corps developed systems are expected to provide the needed capability.

**4.4.3.3 Dissemination and Reporting.** Various types of data will need to be disseminated. The primary means for dissemination will be a computer network, with modems for secondary or backup access. Data dissemination and exchange between the public and non-Corps agencies should be from a separate non-critical computer dedicated to dissemination and exchange (e.g., a bulletin board computer). Access to "critical" computers from this dissemination computer should not be allowed. The "dissemination" computer would be able to obtain selected data from the "critical" computers in a read-only state, such as by using a read-only NFS-mounted drive. Data sent to this dissemination computer would be written to a local disk, from which "critical" computers can obtain the data. The technology of creating and managing home pages on a World Wide Web (WWW) servers that can be accessed by browsers over networks is likely to be the main vehicle for information dissemination.

After the local responsible office has verified selected data, that data will be transmitted over the computer network to other (primarily Corps) offices. Disseminated data may also include forecasts or operations decisions, where appropriate. Any data-quality parameters associated should be sent with the data. The data should be transmitted in a standard format (e.g., SHEF), where appropriate. Selected offices will be able to access the local office's network to view data and information that was not automatically transmitted to them.

**4.4.3.4 Archiving.** The local office is responsible for archiving all data that is used to make operational decisions. This includes, but is not limited to gage data, radar precipitation values, rating tables, logs forecasts, and other information. Any associated data-quality parameters are to be stored with the data. It should be possible to use archived data to duplicate results from any previous time.

**4.4.3.5 Control and Visualization Interface.** The Control and Visualization Interface (CAVI) provides the interface that oversees and controls the operation of the functional modules. The interface will provide the linkage between observed data, models, computed data, operating constraints, and the user. It will include decision input mechanisms, all visualization functions, and an operation evaluation system.

The CAVI will use an evaluation system to validate various conditions and decisions. The intent is to provide a series of machine checks on the reasonableness of data, user input, model results and user decisions. These procedures will apply criteria to data located in a resident data base. The proposed system will be used for several different purposes by the CAVI. This system will differ from traditional evaluation systems in that generally it will be self activating on events and/or time triggers, having criteria telling it where to find the data required to validate an action.

In order to make maximum use of the flexibility inherent in the CAVI system, users must be able to easily modify or extend the knowledge base. The system will require the use of English-like rules and a convenient editing facility. The proposed system will function in both a continuous mode and an operator directed mode.

The continuous mode will be implemented as a constantly running background task that provides a warning mechanism for potentially critical hydrologic, hydraulic, or environmental conditions. In this mode, the system will be primarily accessing observed field data in order to constantly check for various alarm criteria. This operation will have the capacity to go beyond merely checking single values to see if preset limits have been exceeded, by including more complex multiple gage relationships that have been specified in the resident knowledge base.

Once the system has determined that a particular alarm criteria has been met, it will then have the capability to initiate predefined warning messages. The alarm system will include an escalated level of actions depending on alarm severity for both duty and non-duty hours. The alarm system will require acknowledgment that a message has been received or it will proceed with further notification processes.

In addition to warnings generated by hydro-meteorological conditions, the system will also have the capability to check critical gage hardware conditions such as battery voltage, and computer site conditions such as room temperature, excessive power fluctuations, or detectable hardware problems. These problems will be detected and transmitted through the warning system.

User initiated application of the evaluation system will be concerned primarily with modeled or forecasted data. The system will be activated only after one of the transformation functions has been applied. In this mode the system will act in a warning capacity.

In this capacity, the system will check the various model outputs to insure that critical criteria have not been violated. Exactly where the critical points are, and what conditions are to be checked will reside in the system knowledge base. Some examples of this application are; exceeding channel capacity at downstream control points, falling below minimum flow at these points, violating normal pool operating elevations, violating dissolved oxygen requirements, exceeding water temperature limits, excessive rates of increasing or decreasing project outflows, and inappropriate timing of operations (i.e., increasing outflows during the hours of darkness). Approved deviations would be accommodated by the systems.

It must be stressed that these are warning conditions only, the user will always have the option to ignore these warnings if he or she determines that doing so will be appropriate. In effect, this capacity will only provide a set of operational envelopes that will not be exceeded without the operator's knowledge.

The system will also provide an on-line help. It will be able to direct the user through potential model, data, software or hardware problems recommending courses of action to follow.

The system will have the capability to accept user instructions defining a series of modeling tasks to be performed. This linkage of tasks will be in the form of rules defined within the knowledge base. The system will use this knowledge to initiate the user directed operations. Some of this linkage description will be, for example; how the operator input decisions will be archived, what models and functions will be applied to the data, what order these functions will be applied, what configurations will be used by the models, where input data will be found, what and where output data will be saved, and what data will be returned to the visualization module.

The visualization module is the interface to display, capture, print, and integrate database information at the desk top. Whenever possible, embedded operating system capabilities will be used, such as a cut and paste facility to assemble any combination of text, and graphical information into documents or reports. The visualization interface would have much of the character of the widely recognized World Wide Web browsers network product. Linkages would exist from selectable portions of text and graphics to other local and remote information sources.

The primary means by which a user will access information will be via a geographic reference system. Locations will be referenced to actual watershed boundaries defined by Water Resource regions, subregions, accounting units, and cataloging units. At the headquarters level, for example, a map of the U.S. showing the boundaries of Corps division offices would be provided. Corps Division boundaries generally conform to one or more Water Resource Regions. Each division would be selectable by use of a pointing device. The division area selected would be highlighted. A new window would display a map of the selected division showing greater detail such as the district boundaries. In a similar manner selections may be made of a particular district, and/or its major subbasins.

As smaller areas are selected the number and type of features displayed would increase. For example, at the division map level district boundaries, major rivers, cities, state boundaries and larger Corps reservoirs would be shown. At the district level major watersheds with their rivers, additional cities, and all Corps reservoirs would show. At the subbasin level the display would include detail gaging site locations.

The user would have the ability to increase or decrease the amount and type of information displayed at all levels by overriding the default selections. The user would be able to make ad hoc queries of information at a reservoir site or gage site by use of the pointing device. For example, when clicking on a gage site its full name, location, parameters available, and station history would be shown. Alternately, time series data at a reservoir or gage may be displayed graphically or tabulated. This same interface would be used to request model generated data.

Standard displays of data would be provided. These would be activated by selecting from a predefined tool bar. Icons for more complex user defined information requests would be available from a user configured tool bar.

A wide variety of text information is necessary for the performance of the water control function. Water control manuals, ER's and EM's are only a few of the types of text documents that are needed for reference during normal and extreme event operations. Text documents would be made available through hypertext index links. The documents themselves would also be displayed in hypertext to link their table of contents, indexes, and internal cross references.

Certain raster graphic formats will be defined and supported. The Image Visualization software will access the image files allowing the user to view the image, manipulate the image (i.e., pan and zoom), and cut/paste the image into other applications. The following examples of images will be used: satellite imagery, NEXRAD precipitation products, scanned Images (e.g., photographs, as built drawings, etc.), and GIS images (e.g., inundation maps and grids, flood insurance maps, contour maps, property lines, etc.).

The user will have the ability to create vector plots from the database. This software will enable the user to plot and graphically edit database information. The software will allow for user customization of font types, text insertion, line widths, etc. The user will be able to

pan/zoom and cut/paste with this software. The following graphic type of products will be available: time series graphs (e.g., hydrographs), paired data graphs (e.g., rating curves, storage curves, etc.), cross section plots showing water levels, linear plots (profile plots), QPF from NWS, spatial 2D Contour plots, and 3D surface plots.

An industry standard spread sheet will be linked to the numeric database. It will provide the user with the capability to manipulate numeric data and to develop customized macro applications. Customized macro applications will give each water control user the ability to easily create applications unique to their situation.

These components are distinct modules, each doing a specific function. But the final product used in a water control setting may be a combination of any of these components (i.e., E-mail containing text, graphics, and images). Any combination of visualization components can be linked together to create complex, customized documents or hypertext.

Document processing uses industry standard office automation software. Any combination of visualization components can be pasted into the publisher and be viewed, edited, E-mailed, or printed. Software would enable water control personnel to create interactive slide shows composed of any of the visualization components.

Implementable water management decisions evolve from a process of analyzing and coordinating alternative actions and their impacts, and acting within proper authority. In order to meet an identified need or resolve a known or anticipated problem the water manager can specify a range of alternative actions which can be analyzed using the analytical tools and visualization products. These tools and products will normally be linked in standardized data flow paths that are composed for specific basin operations. In cases where repetitive event oriented alternatives are evaluated, the rule defining a specific linkage can be executed as a continuously cycling background task initiated by the operator. This would provide an automatic updating of the functional results. An example of the automatic alternatives could be a set of flood forecasts for a range of rainfall values over a specified time and a series of release options to meet a recession objective.

Equally important is the capability for the user to specify alternatives on a case by case basis or to easily modify the automatic alternatives. Often the decision process must include coordination with others to assess the impacts of the action or to obtain supplemental facts not contained in the data base or available to the water manager. Products such as graphs, maps, and text displaying the potential physical results of the action are generally an essential aid in this coordination process. The process may involve several iterations of multiple alternative operations before a final decision can be made and implemented.

Considerations in the decision making process may include an assessment of impacts both upstream and downstream of the project as well as within the project itself. Tradeoffs between economic, social, and environmental objectives often must be weighed as well as considerations for safety of the structure itself and those it serves. The coordination process may

also include obtaining approval from higher authority within the Corps. This may require comparisons of impacts and risks with previously approved or authorized project performance plans. Once the decision is made, information is disseminated inside and outside the organization.

Examples of products used in the formulation/evaluation process could include "what if" forecasts of inflow for various ranges of precipitation using QPFs or other guides; projected hydrographs, inundation maps, structural damages, crop damages, pool elevation graphs, duration curves, and velocity and timing profiles for various project release schedules.

Similar type products could be displayed for dam safety analysis, environmental considerations, navigation and/or construction activities, hydropower, recreation, fish and wildlife endangered species, and other activities as they occur. As built drawings, pictures, historical records, contracts, compacts, real estate acquisition maps and documents, authorizing documents, inspection reports, etc., are just a few of the resources that could be available for the water manager to access as needed in the decision and coordination process. Once the decision is made and disseminated all text and graphics used in the decision process including a review of the actual benefits and project performance should be archived.



Recreation on Corps reservoir. Photo courtesy of California DWR.

#### 4.4.4 Modeling, Forecasting, Simulation

**4.4.4.1 Flow Forecasting.** Key analytical tools in the suite of water control software will be the streamflow forecasting models. This software will be used to simulate watershed runoff given input data such as precipitation, air temperature, and evapotranspiration information. The streamflow forecasting model will be closely integrated with reservoir system analysis, river system, and other analytical tools to enable comprehensive evaluation of forecast conditions. Following paragraphs summarize some of the applications, features and requirements for the flow forecasting software.

The software will be applied for a range of forecast outlooks, from short-term simulations of a few hours in advance, to long-term projections with a lead time of several months or longer. Short-term forecasts will incorporate the latest real-time data observations and will be able to accommodate quantitative precipitation and temperature forecasts. Long-term projections will utilize input that is based upon historic meteorological time series. An example is the "ESP" (Extended Streamflow Prediction) technique originally developed by the National Weather Service, wherein data input for the outlook period are precipitation and temperature time series from a number of years of historic record. These are simulated, each starting with the current model "state" (soil moisture, lower zone moisture content, snowpack, etc.). The forecast is then developed by statistically analyzing the results of the simulations. Long-term forecasts are typically employed for low-flow forecasting and for employment in snowmelt basins for which the winter accumulation of snow in part determines spring/summer runoff. The model requirements for long-range forecasting include (1) the ability to operate through dry weather conditions in which soil moisture is depleted by evapotranspiration; (2) the ability to simulate soil moisture and ground water contributions to streamflow over an extended period of time; (3) capability to simulate snow accumulation, conditioning and ablation.

To provide frequent forecast updates with a minimum of human intervention the forecasting software should have the capability of automatic updating. Such updating is based on the most recent observations of hydrometeorological data and feeding back corrections based upon comparisons of observed and forecasted streamflow. This will enable the user to always have a recent forecast available. Adjustments can then be made if necessary and a corrected forecast produced in a minimum of time. Model and system requirements needed to provide continual, automated operation include (1) automatic data screening procedures; (2) continuous simulation capability; (3) capability of carrying model state variables forward in time to the next forecast period; (4) ability to feed back information on forecast performance in order to adjust to observed streamflow conditions; and, (5) an automatic, flexible time control and re-computation system.

An important part of the forecasting process involves the initialization of the hydrologic model, in which the model performance for a period prior to the forecast date is used to make adjustments that will lead to improved future performance. A wide range of techniques are currently being investigated and used in the profession, ranging from simple iterative adjustments in model variables or estimated data to more advanced mathematical techniques

such as Kalman filtering. The flow forecasting model needs to have an initialization routine that is robust, yet relatively simple to operate. Initialization needs to be available even in the continual-automated mode of operation.

With the advent of NEXRAD data reporting, improved remote sensing products, and improved processing and display capabilities, it will be possible to define rainfall on a basin with a more detailed spatial definition than has been possible in the past. Hydrologic modeling can capitalize on this improved rainfall imagery by calculating runoff with a similar spatial definition, rather than computing a mean areal precipitation for a basin for a given time period. Thus, the capability theoretically exists to portray a storm moving across a basin in time and space, to more accurately simulate the affects of a storm of limited areal extent falling on part of the watershed, and to more precisely account for variations in soil moisture, snow, etc., within a basin. The ability to accommodate detailed spatial definition in a flow forecasting model requires the depiction of the watershed in a grid cell formulation and the ability to account for basin characteristics and model states independently within each cell.

**4.4.4.2 Reservoir System Simulation.** Reservoir System Simulation (RSS) capability will be provided for simulating the effects of reservoir operations on streamflow, reservoir levels and project-purpose variables . Project purposes will include flood control, navigation, hydropower, water quality management, water supply and recreation. RSS will be designed to employ forecasted streamflow as an input and will utilize water quality and hydrodynamic simulation modules as appropriate. RSS will determine reservoir releases that are consistent with specified operational rules and constraints, insofar as possible. Output from RSS will be a key input for the impact analysis models. RSS will: accommodate reservoir systems of virtually any configuration; employ computational intervals appropriate to the dynamic nature of the phenomena being simulated; accommodate simulation periods of any duration; accommodate Extended Streamflow Prediction inputs and stochastic inputs for drought studies; permit execution in a continual-automated mode; provide substantial flexibility for specification of operational rules; for example, annual storage or elevation rule curves and outflow objectives can be specified, as well as ad hoc rules that supplement or override the underlying rule curves and objectives; determine allowable flood control releases; simulate induced-surge operation of projects with gated spillways; accommodate flow diversions, off-line (pumped) storage, and dynamic flow links between reservoirs (e.g., connecting channel between reservoir pools); translate reservoir releases to a specified set of gate openings for each reservoir; report criteria violations (e.g., exceeding flood stage or flow, or rate-of-change constraints); and maintain accounts of project-purpose reservoir storage and releases.

Specification of control parameters, operation rules, etc., will be via a Graphical User Interface, as will options for visualizing system operation and results. In the longer term, a controller employing systems-analysis optimization techniques may utilize RSS for optimization of system operation.

**4.4.4.3 Water Quality, Sediment Transport and Hydrodynamic Simulations.** In specific instances, specialized simulation models will need to be integrated into a local WCDS.

These models will often be those used for studies by the local Corps office. Those most likely to be integrated locally include water quality, sediment transport, and hydrodynamic simulations.

Offices may have situations in a real-time water control setting where water quality features need to be simulated. For instance, predicted temperature stratification in a reservoir may be needed for a multi-level outlet control operation; or, future estimates of dissolved oxygen, temperature, or other parameters may be required in a river downstream from a reservoir to assist in defining the regulation during a drought. It is envisioned that water quality simulation modules will be available as another computational tool in the overall suite of software, with the ability to be integrated fully with the reservoir and river system software and the data storage system through the Control and Visualization Interface. It is most likely that water quality computation modules will be drawn from existing software; e.g., HEC-5Q, rather than being an extensive new development.

The modeling of sediment transport in a river or reservoir has not normally been undertaken as a real-time water control activity, but instead has been considered an analysis application. Most likely, with the expanded computational and display capability now available, movable-bed modeling will be employed to a greater extent in the future in some offices. In the new WCDS software, sediment transport modeling will not be a specific developmental item; however, the modular design already described will facilitate the usage of this type of model along with the other analytical tools previously described.

Hydrodynamic simulation here refers to the simulation of the dynamic movement of flood wave and other natural and operation-induced flow waves through river-reservoir systems. Results of such simulation include stage and discharge hydrographs, and water surface profiles. The following "routing" methods will be accommodated: lag (i.e., simple time shift), Muskingum, multiple linear reservoir, modified Puls, Muskingum Cunge, diffusion, and numerical solution of St. Venant equations. The routing methods will be utilized for flow forecasting, reservoir regulation, water quality and sediment transport modeling, as appropriate. For routing methods that do not calculate stage, stage-discharge rating curves can be employed, or steady-state profile computations can be performed.

Computational procedures utilized will be based on those embodied in HEC's River Analysis System, where appropriate. This includes capability to define river cross sections (including bridges and other riverine structures), reach lengths and n-values; specify boundary conditions; and perform one-dimensional steady, unsteady and sediment transport calculations. Multi-dimensional hydrodynamic modeling will not be encompassed in the initial version of the software system. However interaction with multi-dimensional models will be possible via the data base.

**4.4.4.4 Impact Analysis.** This module will take various data and model forecast outputs (lake and tailwater elevations, project outflows and river stages and flows) and estimate the impacts of these conditions on various measures of project performance. A primary part of this module will focus on flood damage estimation. More sophisticated methods of flood damage

estimation will be developed than are currently in general use in the field. Real time map presentation and projection of flooded areas will be provided. GIS technology will be utilized for real time projected display and analysis of flooded areas. Critical impact levels will be stored for comparison to projected values and to provide a text description of flood impact. This module will allow for the real time estimation of flood damages prevented by alternative reservoir release scenarios. Initially, the HEC-PBA software package will be incorporated into the WCDS. Later, as resources permit, GIS-based flood damage computations will be incorporated.

Other project outputs will be estimated in this software component. Power generated at site and over a system of projects will be computed. Navigation depths will be estimated from pool levels and project outflows. An important area of impact estimation will be environmental impact. This includes water quality impacts, impacts on fisheries, endangered species impacts, bank stability impacts from river stage variations.

**4.4.4.5 Forecast Evaluation.** Post-forecast evaluation of forecast accuracy can be accomplished with statistical comparisons of forecasted quantities and similar quantities based on observed data. Performing such evaluations enables assessment of the viability of forecast procedures. As new or revised techniques are developed, forecasts based on them can be applied with historical data, and their performance evaluated in comparison with current techniques.

An automated procedure for forecast evaluation will be provided. The procedure will require the designation of specific forecasts for which accuracy will be assessed. The forecast might be the "official" forecast for the day, or any forecast selected by the analyst. Pointers to the parameters associated with the designated forecast, and to associated data and forecast results, will be stored in the data base. When post-forecast observed (verified) data become available, statistical measures of forecast accuracy will be automatically computed. These measures, and graphical comparisons of computed and forecast quantities will be stored for future reference and use.

**4.4.5 Software System.** Figures 4.2 and 4.3 are updates, respectively of Figures 3.2 and 3.3 reflecting the additions needed to the circa 1988-1990 WCDS system to respond to the requirements discussed herein for the modernized WCDS.

**4.4.6 Continuity of Operations.** The nature of water control activities requires staff to monitor storms, floods, routine flows, and droughts, as these affect water control projects, river or lake developments, and population centers. These events can and do occur at any time, requiring around the clock computer support to make the many decisions required to regulate water flow. A key concept of interest to the water control community is reliability. In this regard, a single point of failure criteria is generally accepted. One alternative to each primary system resource is normally required to assure that support for water control activity will continue, if either the primary or alternative resource is unavailable. The requirement assumes that simultaneous failures in separate system components is an acceptable risk. This fundamental concept is for the following requirements:

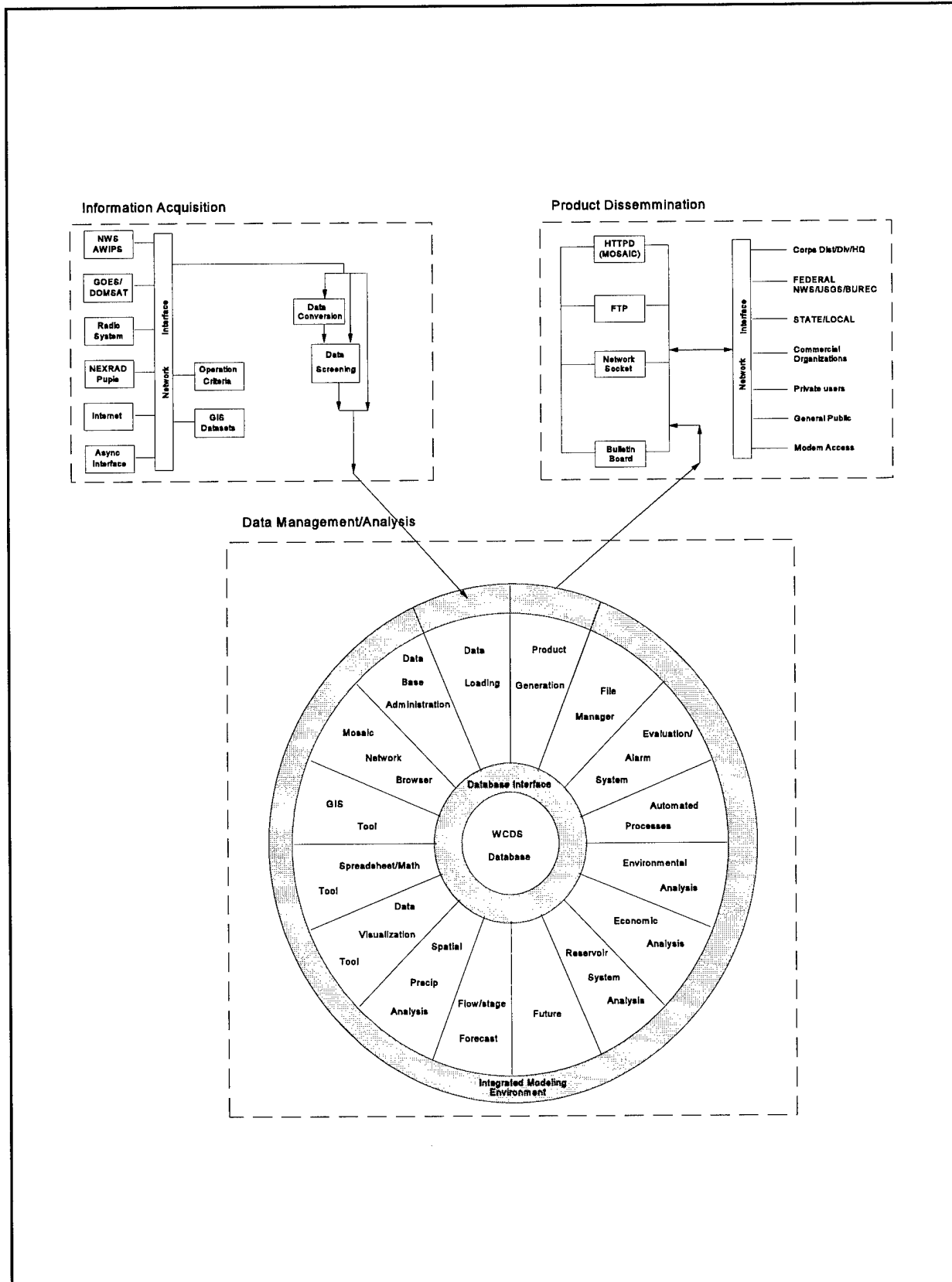

Figure 4.2 Overview, Modernized WCDS Application Software Plan

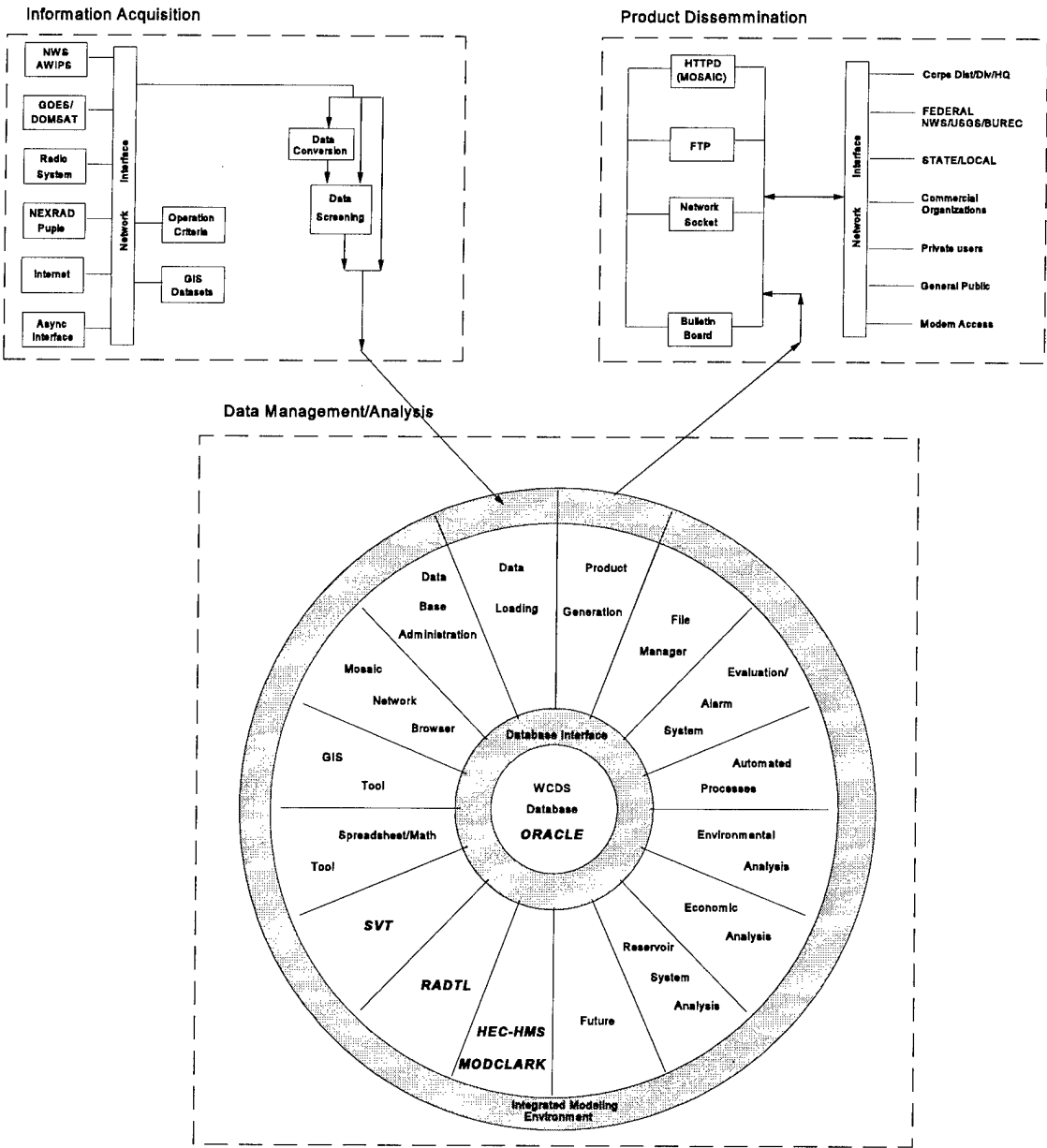

Figure 4.3 Overview, Modernized WCDS Application Software Implementation

**Data/Information Sources.** An alternative source of critical data or information should be accessible to the water control system where it is available and feasible. Critical items likely include: data collection platform; climate and information (AFOS) from local weather office; imagery from GOES satellite; and spatial precipitation from NEXRAD radar sites.

**Data Communications.** Critical communication facilities should have an alternative. Such facilities include: telephone service to project offices; DOMSAT data transmission or Direct Readout Ground Station, CEAP network; and local area (office) network.

**Data Storage.** Critical data, information, and procedures kept on mass storage devices should be redundantly stored on similar devices at a separate location. If a critical item varies rapidly with time, such as hourly precipitation data, then it should be simultaneously and routinely updated on the primary and alternate storage devices.

**Computing Resources.** If a single processor (computer) performing a real time function experiences a failure or outage, then at least one other processor must be available to resume or continue the real time function. A computer performing critical functions such as real time data acquisition, or continuous real time watershed and river modeling, must meet this requirement by continuing the function automatically under computer control. For other less critical functions this requirement can be met by allowing water control personnel to manually perform the switch to another processor.

**Display Dynamics.** If a single point component failure causes the display of complex high volume information to cease or become too slow, then at least one alternate means should be available to provide such display capability.

**Electric Power.** An electric power failure must not prevent functioning of the water control computer system. If the power failure is long term and over a wide geographical area, then the water control computer must continue to operate for an adequate time without normal building power. Where economically justified, a local power source should provide necessary electric power indefinitely or until utility power is restored.

**Dedicated Use of Water Control System.** A dedicated purpose system is required to insure availability in accomplishing the water control mission. Policy which allows others outside water control to set day to day priorities or otherwise restrict access to water control computer systems is inconsistent with the performance of the water control mission.

#### **4.5 Modernized WCDS Costs, Benefits, Investment Flow, and Funding**

The modernization of WCDS is an on-going project that includes acquisition of computer and communications hardware, porting of existing WCDS software, development of new WCDS software, and acquisition of Commercial Off-The-Shelf (COTS) software needed to meet mission requirements for Corps water control management. Chapter 5 describes the current status of the WCDS modernization project. A previous economic analysis was prepared in

conjunction with computer hardware life cycle replacement. Various supporting analyses were prepared in developing and justifying the R&D programs that provide the basis for improvements to WCDS. A specific economic analysis as described in "Department of Army Economic Analysis Manual, Chapter 9, Major Automated Information System (MAIS) Economic Analysis, dated August 1992" has not yet been prepared. This section partially addresses that requirement.

**4.5.1 Analysis Principles, Alternatives.** The principles of economic analysis applicable to major AIS include: definition of objectives; formulation of alternative AIS to accomplish objectives; estimation of costs and benefits for each alternative; and comparison of cost and benefit results as a basis for selection of the preferred plan. The objectives of the WCDS are described in detail in previous sections of this document. In short, the objective is support of the real time water control function through automation of data acquisition, management, analysis and dissemination. The alternatives are: (1) do nothing - continue with circa 1990 system and technology; (2) search out, adopt and adapt systems in existence in other agencies with similar missions - e.g., U.S. Bureau of Reclamation, Tennessee Valley Authority, other state/regional agencies; (3) acquire COTS information acquisition and management system; and (4) modernize the existing WCDS.

Alternative (1) (do nothing) would continue reliance on obsolete equipment, past generation software technology, and ignore opportunities for markedly improved effectiveness afforded by new information sources, such as NEXRAD, and new communication facilities available through the CEAP-IA backbone and the Internet. Adopting this alternative would not preclude upgrade efforts by the field; it would simply occur on a piecemeal, uncoordinated basis, and miss the opportunity and synergism afforded by a centrally managed effort.

Alternative (2) (adopt existing technology of others) was explored to ascertain whether all or part of the requirements could be met in this manner. Several facts became evident: the Corps requirements are unique because the Civil Works mission is comprehensive and nationwide in scope, the Corps has a much larger inventory of water control projects than others, and other federal, state, and local and private institutions are not further advanced, technologically, than the Corps. No viable alternative system was uncovered in the exploration. Opportunities for sharing data, software, and ideas do exist and those contacted expressed great interest in the proposed modernization efforts of the Corps.

Alternative (3) (commercial system) proved to not be a viable alternative since no commercial system on the scale needed and with the requirements specified exists. Some requirements of the modernized WCDS will be most effectively accomplished with commercial software, such as use of the Oracle data base management system for the real time water control data base system. Other commercial products are expected to meet other needs, such as Geographic Information Systems (GIS) and bulletin board-type dissemination. Commercial alternatives to accomplish specific requirements will be determined as WCDS system design and development progress.

Alternative (4) (modernize the existing WCDS) is the logical and preferred alternative for satisfying the water control management mission requirements. Therefore, no further discussion of alternatives to modernizing WCDS is presented herein. Subalternatives of this alternative include the strategies of: grand design, incremental development, and evolution. As discussed later, the incremental development strategy is the logical choice.

**4.5.2 Cost Analysis.** Costs for modernizing the WCDS are estimated and presented as investment totals and time - cash flow. Costs are presented in 1995 dollars.

**4.5.2.1 Program Cost.** The modernized WCDS cost includes all activities needed to upgrade the circa 1988-1990 system to that described in this document. This includes planning, design, and management; new hardware acquisition; circa 1988-1990 WCDS system software porting; software development; training and implementation; and maintenance and support. Table 4.1 summarizes estimated modernized WCDS program cost.

**Table 4.1**  
**Modernized Water Control Data System**  
**Program Cost**  
**(\$1,000's)**

Item	Investment
LCMIS, Oversight, Management	1,050
Computer Workstations	5,500
NEXRAD Hardware, Software	1,930
WCDS Corporate Data Base System	3,800
Corps-wide, COTS, Local Software,	9,900
Mississippi Basin Forecast Model	2,475
<b>Totals</b>	<b>24,655</b>

**4.5.2.2 Program Cash Flow.** Investment in the modernized WCDS is occurring over the period 1992 to the year 2000. Life cycle replacement of computer hardware began in 1992 and is expected to be completed in 1997. NEXRAD activities, supported by research under the Remote Sensing Program, began in 1992 and the initial phase (Corps-wide access and use of Stage I products) will be completed in 1998. The remaining WCDS modernization tasks began in 1994 with the Mississippi Basin Forecast model scheduled to be operational at the end of FY 1997 and the remainder of the WCDS - software and data base - by the end of 2000. Table 4.2 is a tabulation of the cash flow of investment for the modernized WCDS.

**Table 4.2**  
**Modernized Water Control Data System**  
**Cumulative Program Cost**  
**(\$1,000's)**

Item	1992	1993	1994	1995	1996	1997	1998	1999	2000
LCMIS, Oversight, Management	50	100	150	250	425	600	750	900	1,050
Computer Workstations	1,100	2,700	3,800	4,800	5,500	5,500	5,500	5,500	5,500
NEXRAD Hardware, Software	310	480	660	1,040	1,330	1,590	1,740	1,860	1,930
WCDS Corp. Data Base System			100	290	710	1,300	2,130	2,980	3,800
Corps-wide, COTS, Local Software			750	1,850	3,100	4,800	6,500	8,200	9,900
Miss. Basin Forecast Model			475	1,475	1,975	2,475	2,475	2,475	2,475
<b>Totals</b>	<b>1,460</b>	<b>3,280</b>	<b>5,935</b>	<b>9,705</b>	<b>13,040</b>	<b>16,265</b>	<b>19,095</b>	<b>21,915</b>	<b>24,655</b>

**4.5.3 Benefit Analysis.** Benefits of the modernized WCDS are cost savings, reduction in future costs that would have been incurred meeting congressional requirements, and increased effectiveness in mission accomplishment. A benefits and cost analysis was prepared to support life cycle replacement of the circa 1988-1990 computer hardware and is documented in *Life Cycle Replacement of Water Control Computer Systems - Economic Analysis Report* dated October 1991.

The Corps operates 383 reservoirs and additional lock and dam structures for a total of more than 500 water control projects nation-wide. The reservoirs together with 8,500 miles of Corps levees prevent an estimated \$14 billion in damage each year, with damage prevented estimated at \$32.3 billion in 1993. The lock and dam structures serve navigation on 12,000 miles of inland waterways. Power generation, water supply, and environmental enhancement are also provided by these projects. The WCDS is the information system that serves the needs for water control decisions. A very small improvement in water control decision making related to the

Corps system will yield benefits that far exceed the investment in WCDS. This is true for even a single event such as the Mississippi River flood of 1993. The major benefit of WCDS is the accomplishment of project purposes as defined by Congress in project authorization and other purpose-specific legislation. The approach selected for modernizing WCDS must meet these needs and must do so in the most effective way. Quantifying the benefits of the Corps-wide software, corporate data base software, and Mississippi Basin Model is therefore moot to the decision to modernize WCDS. The issue is to accurately define the modernization requirements, define the need and practicality thereof, and set about the project with a systematic management oversight process in place. The requirements have been described in detail, HQUSACE and field validation of needs verified and documented herein, and the LCMIS process adopted for management oversight as a supplement to the existing R&D and water control management supervision.

**4.5.4 Funding Requirements, Sources.** Tables 4.1 and 4.2 document the cost and cash flow requirements for modernizing WCDS. The total project investment cost is about \$24,655,000. Funding sources include Civil Works R&D funds and field office budgeted water control funds (O&M), PRIP funding, and miscellaneous others. Table 4.3 is an estimate of the requirements from each source.

**Table 4.3**  
**Modernized Water Control Data System**  
**Funding Sources**  
**(\$1,000's)**

Fund Source	Estimated Amount
Civil Work R&D	3,705
Field O&M Funds	14,910
PRIP	5,000
Other	1,050
Total	24,655



## Chapter 5

### Current (1995) Water Control Data System Status, Activities

#### 5.1 Overview - Hardware and Software Development

Improvements to the circa 1988-1990 WCDS system have continued. Activities include computer life cycle replacement; upgrade and improvements to data acquisition equipment and software for data acquisition; and improvements in data storage management and reporting; and modeling, forecasting, and simulation. In the years 1990 through 1994, software improvements were incremental and piecemeal in that essentially no R&D funding was available. In FY 1994, a civil works research program entitled 'Real Time Water Control' funded via O&M, began. This program was scheduled for six years and funded at \$4.95 million. It provided a much needed focus for modernizing the WCDS in a centrally planned and managed manner. The real time R&D program is now scheduled for termination following FY 1996. Progress has been achieved toward the modernization goal in both the hardware and software areas. Figure 5.1 depicts the planned phased development and implementation of new WCDS hardware and software under the modernization project. Following sections summarize the status as of 1 September 1995 of the components of the WCDS modernization project.

**5.1.1 Hardware.** Life cycle replacement of the Harris mini-computers with UNIX workstations was approved as described in Section 4.4.1 and acquisition of replacement computers began in 1992. By the end of FY 1995, all water control Harris computers will be retired. As of 1 September 1995, 62 workstations have been procured. Additional workstations are expected to be acquired over the next two to three years. Figure 5.1a. shows this transition and Table 5.1 summarizes the current status of workstation life cycle replacement acquisitions.

The WCDS remote data acquisition and communications equipment additions over the circa 1988-1990 system are an evolving activity. Data collection equipment is replaced and upgraded as a normal part of maintenance and rehabilitation actions, and is considered a normal activity of the WCDS. A new activity, since 1990, which is included in the modernization, has been the development, and initiation of deployment, of equipment to directly access products from the new weather radar, NEXRAD. This equipment is comprised of a Personal Computer with a specially constructed board (the package termed a 'PUPIE') connected to a NEXRAD radar site via telephone line. To date, equipment has been acquired and operation implemented for one site of a total of nine target sites.

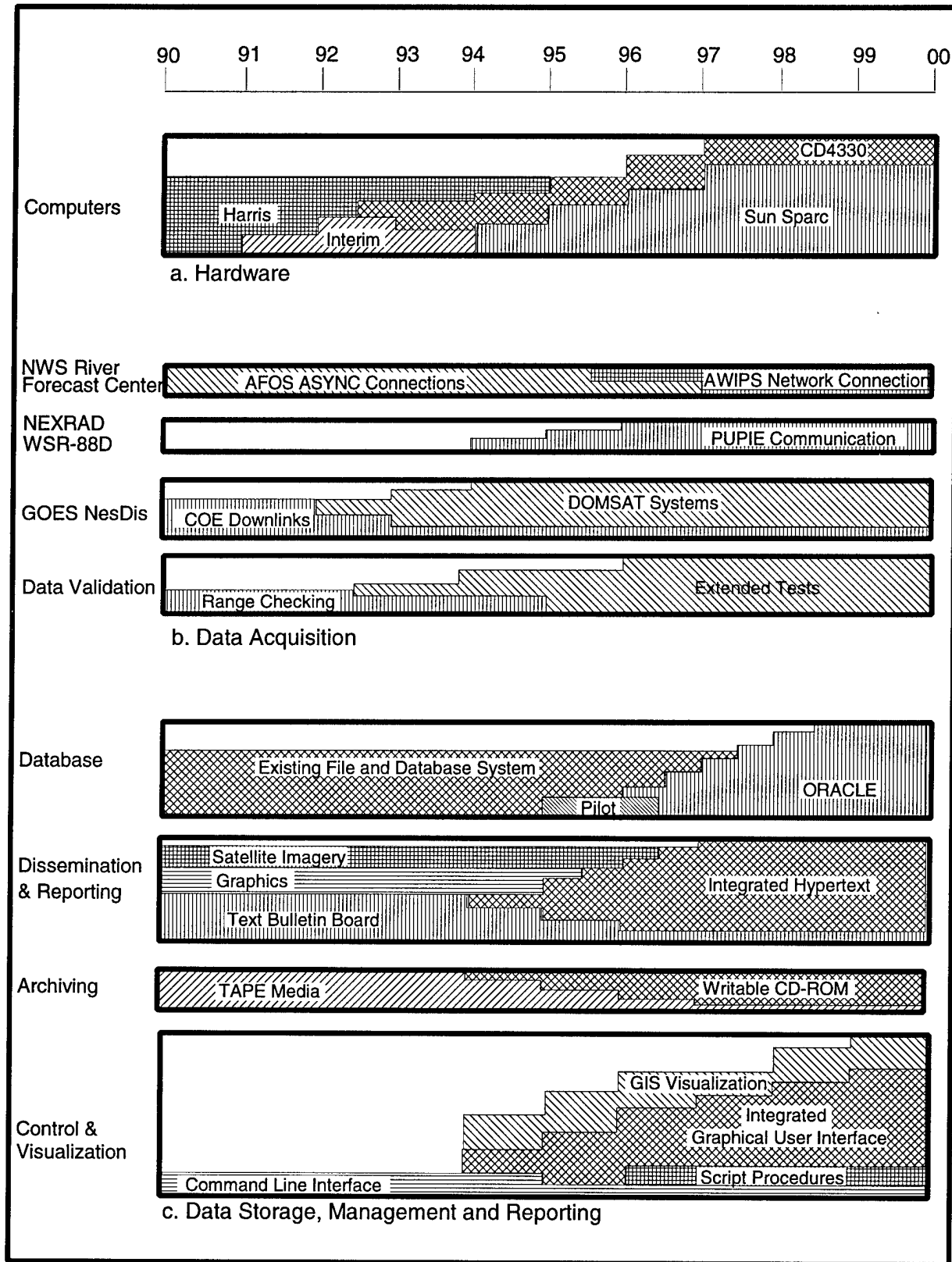

Figure 5.1 Software Transition for Modernized WCDS

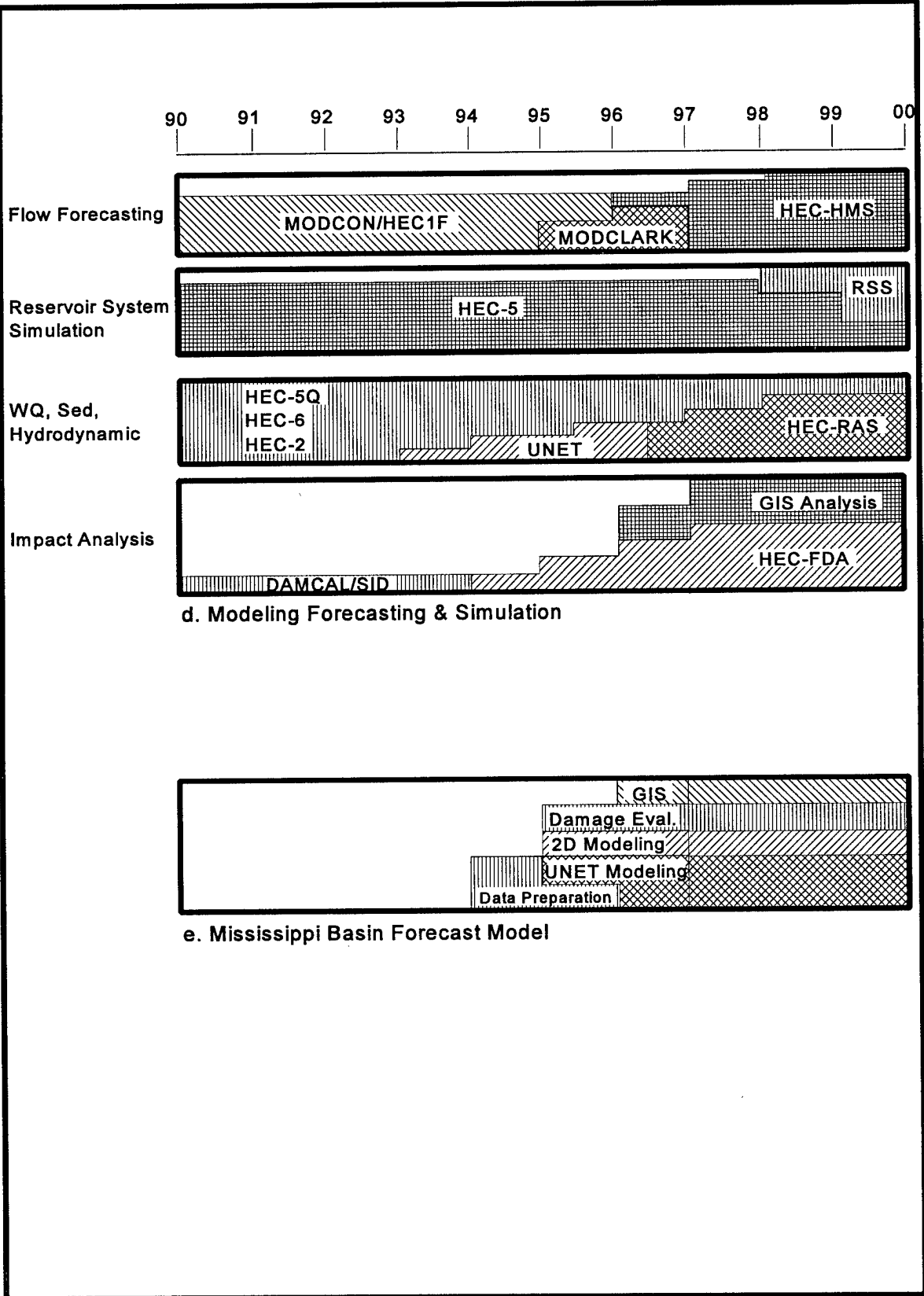

Figure 5.1 (continued)

**Table 5.1**  
**Modernized Water Control Data System**  
**Life Cycle Computer Replacement Status**

Office	Workstation Ac. Status	Workstation Target No.	Comments
HQUSACE	1	1	CD 4330
Divisions	13	26	11 CD 4330's, 2 SUN SPARC
Districts	48	128	36 CD 4330's, 12 SUN SPARC
Labs/others	2	5	1 CD 4330's, 1 SUN SPARC
Totals	64	160	

**5.1.2 Data Acquisition.** The objective of work in this area is to develop effective real time data acquisition and information exchange capabilities between Corps and non-Corps water agencies. To date, circa 1988-1990 WCDS data acquisition software used with the Harris computers has been ported to UNIX workstations and data checking and screening software improved. The general communication system has been designed and bi-directional communications with the NWS have been implemented in a pilot project in the St. Paul District. Software to access NEXRAD radar sites via the PUPIE is completed and undergoing testing. This work is supported by an R&D work unit in the Remote Sensing program. A preliminary version of software to manage NEXRAD data and provide interface to data management systems (RADUTL) has been developed and is also undergoing testing. Figure 5.1b. summarizes the transition from circa 1988-1990 WCDS to the modernized system for the data acquisition categories of NWS River Forecast Center, NEXRAD WSR88D, GOES NESDIS, and Data Validation.

**5.1.3 Data Storage, Management and Reporting.** The near-term objective of this work is the design and development of a Corps corporate water control data base system. As an interim step, the existing time series data management system HEC-DSS, in use by most Corps field office, has been ported to the UNIX workstations. The work will develop a data base technology based on Oracle software that will store and manage information of a wide variety such as: hydrologic data, meteorologic data, water quality data, project descriptions and design parameters, manuals, reports, GIS, maps, satellite images, sound and video. Means and standards will be provided to ensure common nomenclature, data structure, and accessibility for data bases located in all Corps of Engineers water control computer systems. To date, plans have been developed and efforts initiated for a pilot data base system to be developed and implemented in the Missouri River Division. A group comprised of representatives from several field offices provides guidance and oversight for the pilot project. A component of the pilot includes management of GIS and satellite imagery data in Oracle. This capability previously

had been successfully demonstrated. Figure 5.1c. summarizes the transition from circa 1988-1990 WCDS to the modernized system for the data storage, management and reporting categories of Database, Dissemination & Reporting, Archiving, and Control & Visualization.

**5.1.4 Modeling Forecasting, and Simulation.** A number of activities are underway that will contribute to enrichment of the suite of software for modeling, forecasting, and simulation. The circa 1988-1990 modeling software of runoff forecasting (HEC-1F), reservoir simulation (HEC-5), and several district/division packages, precipitation analysis, data utilities, etc., have been ported to the UNIX system. Several new software development projects specifically focused on real time needs are well underway. MODCLARK, an adaptation of the existing HEC-1F runoff forecasting method is now in testing. Software to enable use of DEM data accessible via Internet in conjunction with MODCLARK is also completed and being tested. A preliminary version of a general purpose spatial data analysis and display program - SVT (for viewing precipitation patterns, soil moisture, temperature, etc.) is also undergoing limited field testing. A program that works with real time hydrologic data to estimate river system-wide flood damage has been adapted to the workstation environment and is being test implemented in the Baltimore District. Figure 5.1d. summarizes the transition from circa 1988-1990 WCDS to the modernized system for modeling forecasting, and simulation for the categories of Flow Forecasting; Reservoir System Simulation; WQ, Sediment, and Hydrodynamic Simulation; and Impact Analysis. The simulation models are identified by their existing/proposed acronyms.

As a high priority early implementation of forecasting technology, a special effort is underway to create a Mississippi Basin stage forecasting model. This follows the aftermath of the devastating Mississippi Flood of 1993. The project is a joint undertaking of the several district and division offices within the basin, with support from HEC, WES, and CRREL. The model will be a real time implementation of the UNET unsteady flow simulation model, integrated into the WCDS systems of the Mississippi River Basin. The project began in FY 1994 and the initial phase will be completed at the end of FY 1997. Progress to date includes porting UNET to the UNIX system, assembly of preliminary data, and a public demonstration of the forecasting system based on the flood of 1993. A number of products developed in the WCDS modernization project will be used in the forecast model implementation. Later, as additional products are completed, the initial project model will be adapted to effectively use their capabilities. Figure 5.1e. summarizes the development and implementation of the Mississippi Basin Forecast Model. Appendix B contains a more detailed description of this project.

## **5.2 Summary.**

Software development is underway in each of the categories summarized in Table 3.3. Initially, components of the circa 1988-1990 WCDS software were ported to provide functionality in the new workstation based WCDS. As the modernization effort progresses, replacement software will be developed and implemented for the relevant portions of the software. As new models and software are developed and tested, they will be implemented in the WCDS.



## Chapter 6

# Life Cycle Management of Automated Information Systems (LCMIS) for WCDS

### 6.1 Overview of LCMIS Process

LCMIS is the Corps of Engineers formal process for managing the formulation, development, deployment, and maintenance and servicing of Corps-wide Automated Information Systems (AIS). The process requires systematic development and documentation of plans, progress, and decision information for senior management approval. The process is comprised of a sequence of phases separated by decision milestones beginning with the mission need justification phase and concluding with the operations and support phase. New systems and improvements/replacements of existing systems must be managed via the LCMIS process. Provisions are made for tailoring the process to enable incremental development and fielding of components of the system. The management decision level is determined by the scope and cost of the system, ranging from local Information Management chief for Class VI systems (up to \$250,000) to Army MAISRC for Class IV and III systems (\$25 million to \$100 million). Following paragraphs provide additional description of important elements of the LCMIS process. Army Regulation 25-3 *Army Life Cycle Management of Information Systems*, dated December 1989 and *Managers Guide to Life Cycle Management of Automated Information Systems*, Version 1.0, dated March 1994, provide detailed descriptions and guidance for LCMIS implementation.

### 6.2 Life Cycle Phases and Decision Milestones

LCMIS defines a number of life cycle phases of AIS development and deployment with decision milestones as the concluding event of the phase. The phases are: Mission Need Justification; Concept Exploration and Definition Phase; Demonstration and Validation Phase; Development Phase; Production and Deployment Phase; and Operations and Support Phase.

**6.2.1 Mission Need Justification (Milestone O).** The LCMIS process begins with the development of a justification of the mission need -- a statement of why the organization needs to create and deploy the proposed AIS. This statement provides the basis for subsequent system functional descriptions and specifications and ultimately on the acceptance of the system. It concludes with the decision to proceed with concept studies.

**6.2.2 Concept Exploration and Definition (Milestone I).** This phase explores the opportunities and alternatives to available to satisfy the mission need. Functional needs, costs funding, deployment and operations are issues that are explored and documented. A number of specific submittals are required to support the decision to proceed with concept demonstration activities. The submittals required are listed in a subsequent section.

**6.2.3 Design, Demonstration, and Validation (Milestone II).** This is the first technical stage in which prototypes may be built and tested. Technical details of system design, methods, development strategies, and detailed production plans are developed, tested, and finalized prior to production and deployment. This phase concludes with the decision to proceed with development and deployment.

**6.2.4 Development (Milestone III).** Full developmental effort is commenced and completed in this phase. The system is coded, integrated, tested, user validated, documented, and prepared for deployment. Actions to ensure effective deployment and use are planned in detail. This phase ends with a decision to proceed with production and deployment.

**6.2.5 Production and Deployment.** This phase includes AIS duplication, distribution, and installation. User training is completed. Data bases are populated as needed, and transition from existing system use to the new system is completed. Phased deployment is usually the mode for complex, multi-component systems.

**6.2.6 Operations and Support (Milestone IV).** This phase is characterized by the operations and maintenance duties for the system and continued training to keep the system fully operational. Also included is periodic performance testing and capability assessments to ensure the evolving needs are met. This phase ends at some point in time with a milestone decision initiating major system modification needed to meet new requirements.

### **6.3 WCDS and LCMIS Compliance**

To date, the project to modernize WCDS has not been managed within the formal LCMIS process. In circa 1988-1990, WCDS would have been depicted as in Phase IV, Operations and Support. Modernization of WCDS is estimated to cost \$24.65 million, which results in classifying the modernized WCDS as a Class IV system, requiring milestone approvals at the HQUSACE level.

Significant actions have already taken place towards WCDS modernization that include life cycle replacement of computer hardware and initiation of product development under Civil Works R&D programs. Software development is occurring on an incremental basis with some products nearing readiness for fielding while others are in the definition phase. The path that seems most reasonable for bringing the WCDS modernization project into LCMIS compliance is to adopt the Program Strategy of 'Incremental Development' and proceed with actions to achieve Milestone I/II decision as the first step. Subsequently, a strategy will be formulated and executed for bringing the WCDS project into LCMIS compliance by the end of 1995.

One of the purposes of this report is to provide a foundation of information from which actions may be taken to bring the WCDS modernization project into compliance with LCMIS. Documents will be prepared drawn from information herein, and supplemented where necessary, in support of the Milestone I/II submittal include:

Mission Needs Statement

Project Management Charter

Baseline Plan/Agreement

Initial Functional Description

Economic Analysis

System MANPRINT Management Plan

Test and Evaluation Master Plan

Security Plan

Telecommunications Plan

Transition Plan

Configuration Management Plan

Integrated Logistics Support Plan

Data Management Memorandum

Legal Review

Metrics

System Decision Paper

As these and subsequent LCMIS decision materials are prepared and submitted, they may be appended to this report to ensure complete, living documentation of the WCDS modernization project.



## Appendix A

### Glossary of Abbreviations and Acronyms

#### A.1 Organizational - Institutional

**CEAP** Corps of Engineers Automation Plan (particularly CEAP III and CEAP-IA), Corps-wide hardware and software acquisition plan and associated procurement contracts.

**CRREL** Cold Regions Research and Engineering Laboratory, US Army Corps of Engineers.

**FTAG** Field Technical Advisory Group comprised of senior water management staff from Corps of Engineers division offices. A body that advises HQUSACE on water management matters.

**HEC** Hydrologic Engineering Center, US Army Corps of Engineers.

**HQUSACE** Headquarters, US Army Corps of Engineers.

**LCMIS** Life Cycle Management of Information Systems, US Army software development and management process.

**NRCS** National Resources Conservation Service, formerly known as Soil Conservation Service.

**NWS** National Weather Service.

**NWS-RFC** National Weather Service River Forecast Center.

**USGS** US Geological Survey.

**WES** Waterways Experiment Station, US Army Corps of Engineers.

#### A.2 Data-related

**ALERT** Automated Local Evaluation in Real Time, small-scale flood forecasting systems sponsored by the National Weather Service.

- AWIPS** National Weather Service Advanced Weather Information Processor System, planned replacement for NWS-AFOS system.
- DATACOL** Data collection “dial-up” service at NESDIS for GOES data. Being replaced by DOMSAT.
- DCP** Data Collection Platform, a field site that gathers and transmits data to a receiving site.
- DOMSAT** Domestic Communication Satellite, a commercial satellite system that uses small dish antenna technology. Commercial services provide processed NESDIS information using this satellite and DROT.
- DROT** DOMSAT Receive Only Terminal, government owned device used to receive NESDIS data at local site via DOMSAT. The DOMSAT Receive Station (DRS) is the commercial version of DROT which has many and varied value added features depending on the vendor.
- GOES** Geostationary satellite that performs data relay functions.
- IFLOWS** Data collection system similar to ALERT which consists of a network of Personal Computers. IFLOWS is used in the Eastern and Southern United States.
- NESDIS DAPS** National Environmental Satellite Data Information Service - Data Automatic Processing System. Site at Wallops Island, Virginia which receives GOES data, then relays it to DOMSAT.
- NEXRAD** Next Generation Radar, refers to NWS WSR-88D new doppler radar.
- NWS-AFOS** National Weather Service Automated Field Operating System, the NWS data network.
- PUPIE** Principal User Processor Interactive Emulator, software for direct Corps acquisition and display of NEXRAD data from radar sites.
- SHEF** Standard Hydrologic data Exchange Format, a standard data format for exchange of hydromet data among Federal agencies.
- SNOTEL** A data collection system operated by NRCS based on meteorburst communications technology. Two receive sites at Boise, Idaho and Ogden, Utah receive snow water equivalent, air temperature, and precipitation data for the entire western U.S. Data from SNOTEL is processed at the NRCS forecast office in Portland, OR.
- QPF** Quantitative Precipitation Forecast, a product of the NWS that is a future in-time forecast of precipitation.

**WCDS** Water Control Data System, the data acquisition, management, modeling and decision support system that supports the Corps water control mission.

### **A.3 Software-related**

**CAVI** Modernized WCDS Control and Visualization Interface.

**COTS** Commercial Off-The-Shelf, refers to software readily available on the commercial market.

**CROHMS** Columbia River Operational Hydromet System, an implementation of a commercial IBM-based network data base system by the Corps North Pacific Division. CROHMS is a Pacific Northwest inter-agency data base hosted by the Corps.

**FLOWSED** An unsteady-flow simulation software package adapted to forecast application on the main stem Ohio by the Corps Ohio River Division.

**FTP** File transfer protocol, software for transferring files between computer systems.

**GIS** Geographic Information System, software for managing map-type and other geospatial data.

**HEC-DSS** Hydrologic Engineering Center Data Storage System, a software package for managing time series, paired function, and spatial time series data.

**HEC-1F** WCDS software for performing streamflow forecasts.

**HEC-2** General purpose one-dimensional steady-flow software package adapted for WCDS.

**HEC-5** General purpose reservoir system simulation software adapted for WCDS.

**HEC-5Q** Reservoir system water quality simulation extension to HEC-5.

**HEC-PBA** HEC Project Benefit Accomplishments software package for computing river system-wide flood damage and benefits adapted for WCDS application.

**HEC-RAS** River Analysis System, general purpose river hydraulics software package, successor to HEC-2, adapted for WCDS.

**HEC-HMS** Hydrologic Modeling System, the new generation (under development) HEC general purpose precipitation - runoff software package adapted to WCDS forecast needs.

**HTTPD** Hyper Text Transfer Protocol Daemon. Provides World Wide Web access or service to a computer and its "home pages."

**INTERNET** Acronym for the international computer communications network.

**MODCLARK** A WCDS software package that process spatial precipitation, such as available from NEXRAD, into spatial runoff.

**ORACLE** A commercial relational data base management system that is the standard adopted by the Corps of Engineers and available via the CEAP-IA contract.

**PRECIP** WCDS software for manipulating precipitation data.

**RADUTL** A HEC-DSS software utility program for processing and managing spatial time series data, such as that generated by NEXRAD.

**SSARR** Streamflow Synthesis and Reservoir Regulation, a watershed/reservoir software package developed by the Corps North Pacific Division.

**SQL** Structured Query Language, a standardized data base management system query language.

**SUPER** A reservoir system simulation software package developed by the Corps Southwestern Division.

**SVT** Spatial Visualization Tool, a software package developed for WCDS for display of spatial data.

**UNET** General purpose network-structured one-dimensional unsteady-flow river hydraulics software package adapted for WCDS.

**UNIX** Computer operating system supporting multi-tasking, network distributed processing which is the standard for engineering workstations on which WCDS is based.

## **Appendix B**

### **Mississippi Basin Forecast Model**

#### **B.1 Mississippi Basin Forecast Model**

The Mississippi Flood of 1993 exposed the need for a Mississippi main-stem stage forecast model. The Corps does not now have an integrated river model or procedure specifically designed and implemented for the Mississippi River to analyze and predict system-wide impacts of various alternative actions during large floods such as were experienced in that area during the summer of 1993. Although reservoirs were effectively operated during the 1993 flood, improvements are necessary in the prediction of runoff, reliability of stage forecasts during extreme events, analysis of the impacts of actual or probable levee failures (both locally and downstream), and communications between Corps offices and with Corps customers.

One of the critical elements needed to manage the system is the time series of inflows from tributaries to the main-stem Mississippi River. Such information can be obtained once the real-time water control models for all of the major tributaries are operational. During extreme hydrologic events, such as the '93 flood or the drought of the '80's, intensive coordination among the five divisions is required to effectively manage and evaluate the performance of Corps Mississippi River tributary projects. Quick, accurate, and effective communication of Corps actions and forecasts to other parties during such events is also important. Investigation of these experiences has identified the following general needs (listed in priority order) that such a model could, and should, satisfy:

1. Improve and facilitate the coordination, communication, and sharing of data and forecasts among water control activities along the main-stem Mississippi River during all hydrologic conditions ranging from low flows to floods. This can be accomplished through the use of a uniform and consistent channel routing model and data management/display system.
2. Assess impacts of levee breaching and floodway operations on local and downstream areas.
3. Support emergency management activities through timely prediction of stage and rate of rise.
4. Display areal extent of flooding potential for various predicted weather scenarios and levee failures.
5. Identify navigation hazards.

6. Provide real-time flood damage assessment.

The model must operate in at least two modes: (1) Operational; that is, used on a routine (say daily) basis to provide forecasts of stages; and, (2) As a study tool to evaluate the impacts of physical modifications to the system; e.g., levee breaches or construction, channel changes, etc. A mechanism must be developed, and agreed to, that maintains data integrity. For modeling reasons, there will be some overlap of geometric data on several reaches of the system. For some users, these reaches will only serve the purpose of avoiding uncertainties associated with boundary conditions; for others, they will be reaches of interest. The data needs to be managed and certified by the office of primary use.

## **B.2 Areal Extent**

The Mississippi River Basin Model will consist of a network of unsteady flow models for the main-stem Mississippi River and its major tributaries including the Illinois, Missouri and Ohio Rivers. The areal extent of the river models is shown on the attached map and summarized as follows:

Mississippi River	-	Minneapolis to the mouth
Illinois River	-	Chicago to the mouth
Missouri River	-	Gavins Point Dam to the mouth
Ohio River	-	Pittsburgh to the mouth

Hydraulic models are not currently planned for the Arkansas and White Rivers. Rather, forecast inflow hydrographs will be developed at Dam 2 and Clarendon using currently available methods.

Also, real-time water control models need to be developed to forecast inflows from major tributaries and critical ungaged basins as needed. The areal extent of these hydrologic models is not defined at this time. Also, the forecast future period (e.g., 1-2 days, 1-2 weeks, or 1-2 months) is critical. Longer forecast periods will require incorporation of the upstream basin condition; whether it be rainfall, snowmelt, reservoir releases, or whatever. The forecast time frame affects both local (say Division-wide) activities and downstream communications.

## **B.3 Analytical Procedures**

A network of one-dimensional unsteady flow models will be used to forecast the flows and stages for the main stem river reaches. Except for the Ohio River, where the FLOWSED model has already been implemented, UNET will be the hydraulic modeling tool. Each division/district will be responsible for the development and use of their portion of the Mississippi River Model and will pass the results of their portion of the model to a central location for use by other offices.

Two-dimensional unsteady flow modeling will be used in selected areas where dictated

by flow conditions. Two likely areas for this type of modeling effort are the Birds Point-New Madrid Floodway and the floodplains surrounding the junction of the upper Mississippi, Illinois and Missouri Rivers. Other possible locations may be identified as the study evolves. The appropriate mechanism for coupling of 1-D and 2-D models remains to be determined.

#### **B.4 Input Requirements**

The Mississippi River modeling system will be configured as a distributed model. Each section (or reach) of this model will be run at the division or district office that has responsibility for that particular reach. Those offices will each be responsible for the development of the model geometry for the individual reaches within their boundaries with assistance from HEC, WES, and the contractor. The offices will also be responsible for the acquisition and screening of the boundary condition data required to operate the model for their reach of interest.

Application of an unsteady flow model requires a representation of the channel and overbank cross sections, roughnesses, reach lengths and storage areas to quantify the conveyance and storage in the system. There are substantial numbers of cross sections available for the Mississippi River system now. The first priority for the development of input data is the construction of an inventory of existing cross section data, obtaining those data, and assembling a UNET input data file. Cross section data format for the UNET model is essentially the same as that for HEC-2, used for most all Mississippi River cross sections obtained to date. Additionally, those reaches of the basin for which this study constitutes an initial hydraulic model development (Upper Mississippi and Missouri reaches) will have the cross section data available in a format compatible with future use of geographic information systems (GIS).

The model input structure and user interface must allow for rapid changes to data such as anticipated inflows from ungaged areas and geometric data such as levee elevations/breaches, etc., and restart therefrom.

The model must be able to use as input the results of a previous execution; this is termed "hot start" capability. Essentially, it consists of the model producing a file of stage and flow (and, depending on the solution scheme, derivatives of stage and flow) at all computational nodes for use as input (i.e., initial conditions) for subsequent model executions. Data assimilation techniques may be needed to ensure that errors from previous computations associated with "hot starts" are not cumulative and, therefore, carried forward into future forecasts.

Discharge hydrographs need to be provided at all upstream extremities of the model (see "areal extent"). Important also are the intervening inflows; improvement of the computation/prediction of these flows will require an additional effort that will be necessary regardless of the channel routing technique used.

The model should be able to use a stage hydrograph as an upstream boundary condition as well as a discharge hydrograph. The analyst will choose whichever is appropriate for the application. Downstream information (flows, stages, etc.) computed by each office will be made

available in a predetermined format (e.g., SHEF/DSS). Those values will then be used as upstream boundary conditions for succeeding reaches.

Tributary inflow forecasts and real-time stage/flow data at key locations will serve as input to the individual segments of the model. In the upper reaches of the Mississippi River Basin Model, inflow hydrographs will be developed using either the currently available methods (whether they are empirical methods or process-based models), or real-time hydrologic models may be developed for major tributaries and ungaged areas. In the lower reaches, output from the upper reaches and major tributaries UNET models will be used as input. Additionally, real-time hydrologic models may be developed to forecast critical tributaries and ungaged areas. Regardless of how the input hydrograph data to the UNET models is generated, it will be input into the UNET model and passed to downstream models via HEC-DSS. It is expected that, to maintain boundary condition integrity, a certain amount of overlap may be required at the interfaces of each of the modeling reaches.

## **B.5 Output Requirements**

The model output must be readily available and usable for at least three purposes:

1. Use and interpretation by the analyst for quality assurance, associated parameter calibration and sensitivity testing.
2. Transfer of results (forecasts) to downstream Corps offices. This requires a uniform format for data, vertical datums, times (e.g., Central (CST) or Zulu (UTC)), and location identifiers (river mile conventions).
3. Presentation/communication of forecasts to the public, local governments, other agencies, etc. This may involve both the transfer of "hard" data, such as stages at critical locations, velocities for constituent transport modeling, or mapping type of data, for visual display of areal extent of flooding and estimation of flood damages. The latter requires development of an interface with a digital terrain model or GIS.

Output from the Mississippi River Model will consist of both stage and flow forecasts at designated locations along the main-stem and at the downstream boundary. As a minimum, forecasts will be developed for all USGS gaging stations currently forecast by the NWS.

Initially, output data will be available in tabular and graphical format at selected locations along the main-stem rivers. Future integration with a GIS will allow inundation mapping to be generated as well.

## **B.6 Hardware Requirements**

Because the UNET program and HEC-DSS are available for both the PC and UNIX workstation environments, individual districts and divisions will decide the type of platform their

segment of the model will operate on. However, those working in a PC environment will likely need to use the dedicated water control workstations to handle data storage and manipulation for the model. It will be preferred, however, that all data and model executions be done on the water control UNIX system with PC's used to control model execution and access to information for presentation and communication.

Exchange of information between the divisions, districts and headquarters will be done via the CEAP network. Consideration will be given to implementation and maintenance of the model on redundant systems in case of hardware failure during a critical event. Exchange of information with other users will be via the Internet.



## Appendix C

### WCDS Briefing Package, 5 May 1995 IPR

#### Chart I

### WATER CONTROL DATA SYSTEM

**Water Control Data System (WCDS)** is the automated information system (AIS) that supports the Corps of Engineers water control mission including the hardware, software, manpower and other resources required to acquire, develop, maintain, operate, and manage the system. The WCDS includes the collection, acquisition, retrieval, verification, storage, display, transmission, dissemination, interpretation and archival of data and information needed to carry out the water control mission of the Corps. Typically this data and information includes hydrologic, meteorologic, water quality, and project data and information. The system collects data on a near continuous basis from thousands of sensors throughout the nation. In addition the system collects spatial satellite and radar imagery, graphical products, text products, lab and field analyses of chemical, physical and biological samples. The system through it's software incorporates this data and information into various user products and system outputs. The WCDS is a nationwide integrated system of hardware and software that allow user access to virtually any data and information in the system. A suite of software gives users the ability to display, manipulate, disseminate, interpret, and transmit this information throughout the Corps and to numerous other interested users.

## **Chart II**

### **BRIEFING OUTLINE:**

- BACKGROUND
- TOTAL LIFE CYCLE COST
- INTERFACE WITH OTHER SYSTEMS
- OTHER SYSTEMS (CORPS & NON-CORPS) HAVING SIMILAR CAPABILITIES
- PLANNED FUTURE CHANGES/MODIFICATIONS

### Chart III

#### BACKGROUND:

- **PURPOSE OF SYSTEM.** Provide the Water Manager with a set of modern tools with which to accomplish the Corps water control mission within the available resources.
- **MISSION.** Water Control is the prime ancillary mission born from the Corps water resources development mission. The Corps of Engineers is responsible for regulating more than 500 water resources projects. Currently more than 350 single and multiple purpose reservoirs and 150 locks and dams are operated in accordance with water control plans designed to carry out the legislation. Water control has evolved into a real-time 24-hour per day, 7-day per week responsibility dependent upon continuous collection, processing and interpretation of data. Forecasting, preparation and dissemination of regulation instructions is also a round the clock task.

The water control mission is the one Corps mission that has a direct bearing on the health, safety and welfare of the general public. Substantial benefits are derived from water control management of Corps projects. The average flood reduction benefit over the last 10 years is \$14 billion per year. Other benefits include navigation, power, water supply, and environmental enhancement. Reservoir regulation decisions during both normal and emergency situations have a profound effect on the public and the environment and are thus the subject of close scrutiny. It is essential that the mission be supported by information resources sufficient to meet these rigorous demands.

Modernization program completion planned by the year 1999.

- **FUNCTIONAL PROPONENT - WATER CONTROL/QUALITY SECTION (CECW-EH-W)**
- **POST DEPLOYMENT SOFTWARE SUPPORT MANAGER - Hydrologic Engineering Center (CEWRC-HEC)**
- **USERS** **NUMBER**
  - Water Control Personnel & Managers ..... 527
  - Staff Briefing ..... 601
  - Daily Reports ..... 3,820
  - Project People ..... 1,167
  - Study Managers & Staff ..... 306
  - Bulletin Boards or Phone Information Systems ..... 10,000
  - National Weather Service ..... 426
  - Bureau of Reclamation ..... 204
  - US Geological Survey ..... 284
  - Federal Hydropower Marketing Agency & Customers ..... 191
  - Navigation Interest ..... 1,213

- State Agencies .....	603
- City & Local Government .....	2,021
- Other .....	2,050

- DATE STARTED - 1985
- DATE OPERATIONAL - 1990
- INVESTMENT COST CUMULATIVE TO 1990 - (\$79 million)
- ANNUAL COST OF OPERATION - (\$39.4 million)  
     .... includes \$18.6 million data collection cost

- PLANS FOR BRINGING WCDS MODERNIZATION UNDER LCMIS PROCEDURES

- A. Document plan for modernizing WCDS that includes all of the district and division modernization needs.
- B. Prepare the required LCMIS documentation and obtain approvals to move into a full modernization program.
- C. Continue current activities as planned.
- D. Schedule:
  - 1. In-Progress Review (IPR) Meeting - 5 May 1995.
  - 2. Develop Milestone I decision documents following instructions obtained at IPR and submit to CEIM-L.
  - 3. Schedule Milestone I meeting.
  - 4. Meet LCMIS by the end of FY 1995.

## Chart IV

### TOTAL MODERNIZED WCDS LIFE CYCLE COSTS:

- PROGRAM COST ..... \$23.4 million (through FY 1999)
- ALL PRIOR FY EXPENDITURES ..... \$ 3.9 million
- FY 1995 BUDGET ..... \$ 3.3 million
- FUNDING SOURCE ..... O & M , R & D
- ESTIMATED ANNUAL OPERATION & SUPPORT COST BY PLANNED YEARS

FY 1995	FY 1996	FY 1997	FY 1998	FY 1999
38 Million	38 Million	37 Million	37 Million	36 Million

- ESTIMATED-TO-ACTUAL COST VARIATION

- FIGURES

- WCDS - Hardware
- NEXRAD - Data Acquisition
- WCDS - Data Base
- Mississippi Basin Forecast Model
- WCDS Software

- BENEFITS

Average annual flood damage prevented      \$14 billion/yr

FY 1995 budget for Water Management      \$80 million

WCDS	\$38.0
Modeling	\$ 7.6
Water Quality	\$ 6.7
Forecasting/scheduling	\$16.3
Manuals/coordination	\$ 5.9
Other Duties	<u>\$ 5.5</u>
	\$80.0 million

# WCDS - Hardware

Workstations

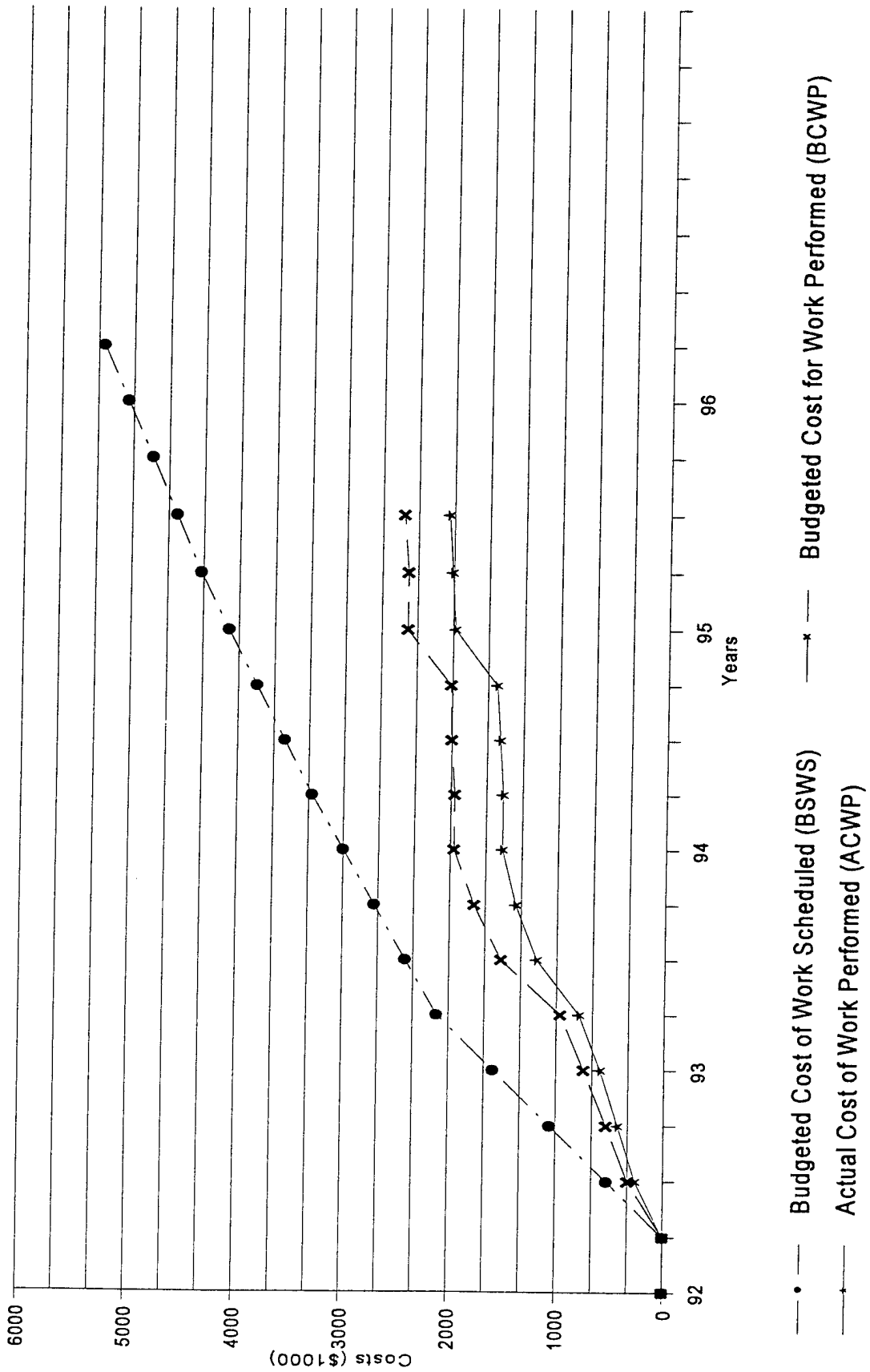

# NEXRAD - Data Acquisition

PUPIE's & NEXRAD Site Datalines

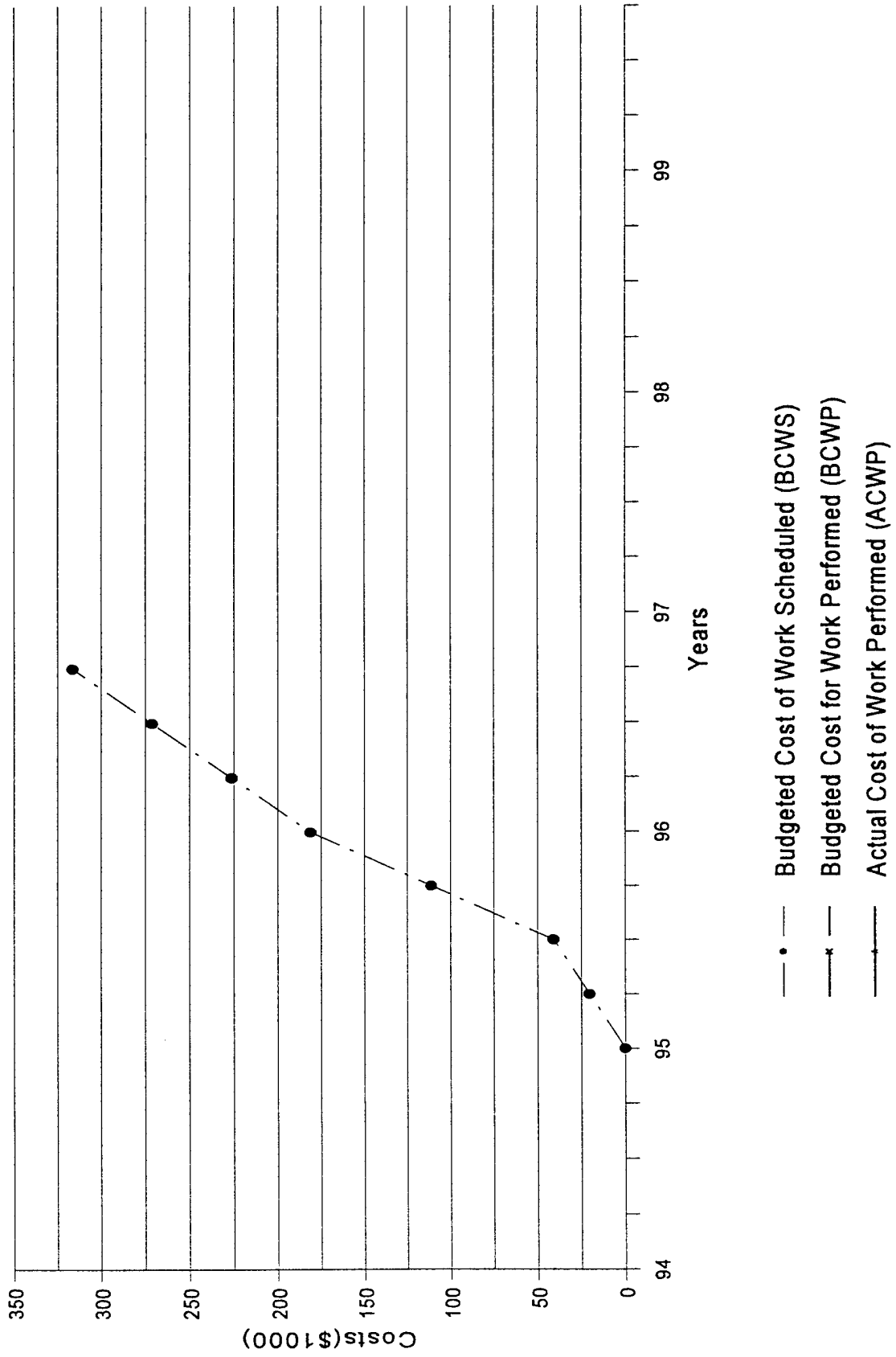

# WCDS - Data Base

ORACLE

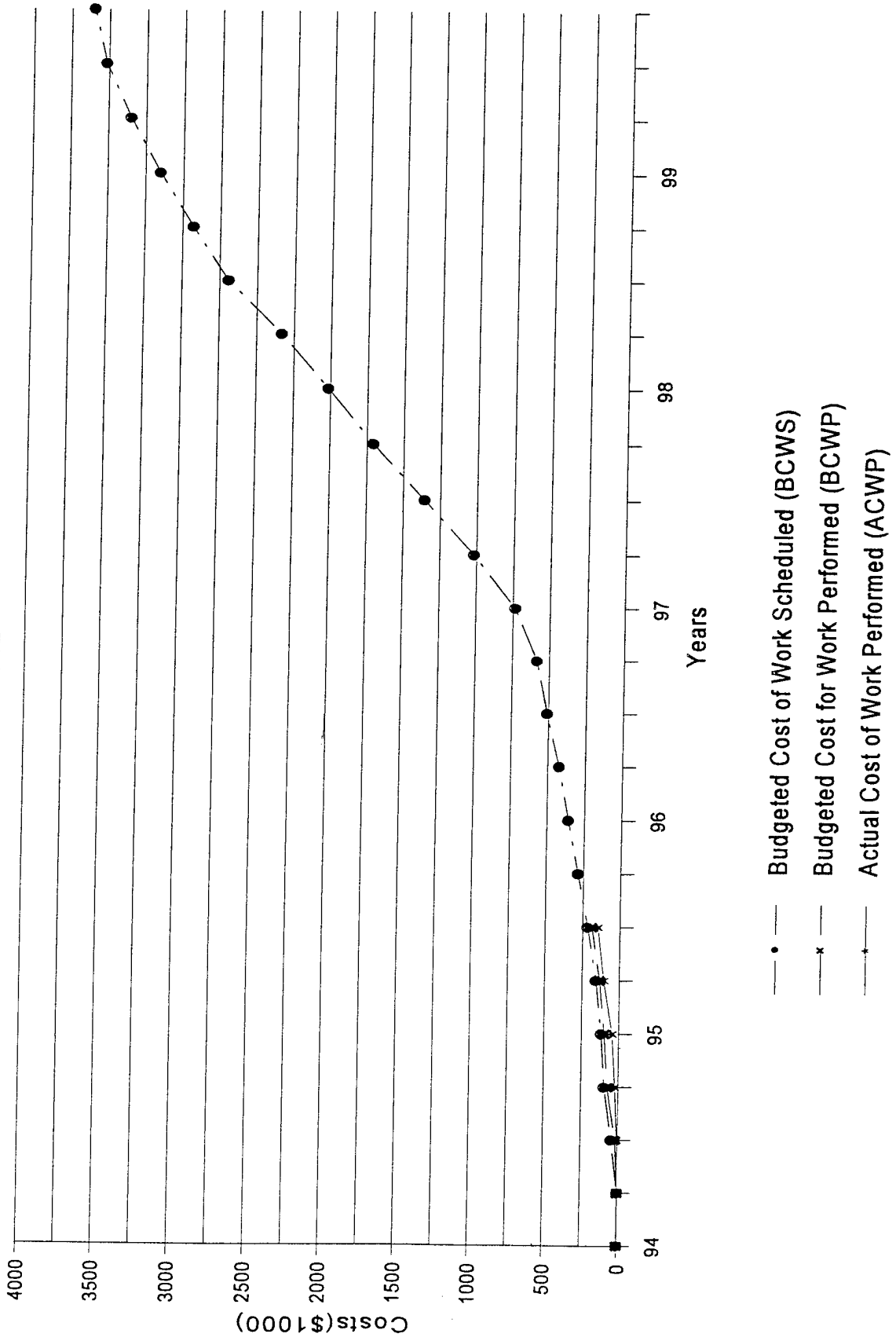

# Mississippi Basin Forecast Model

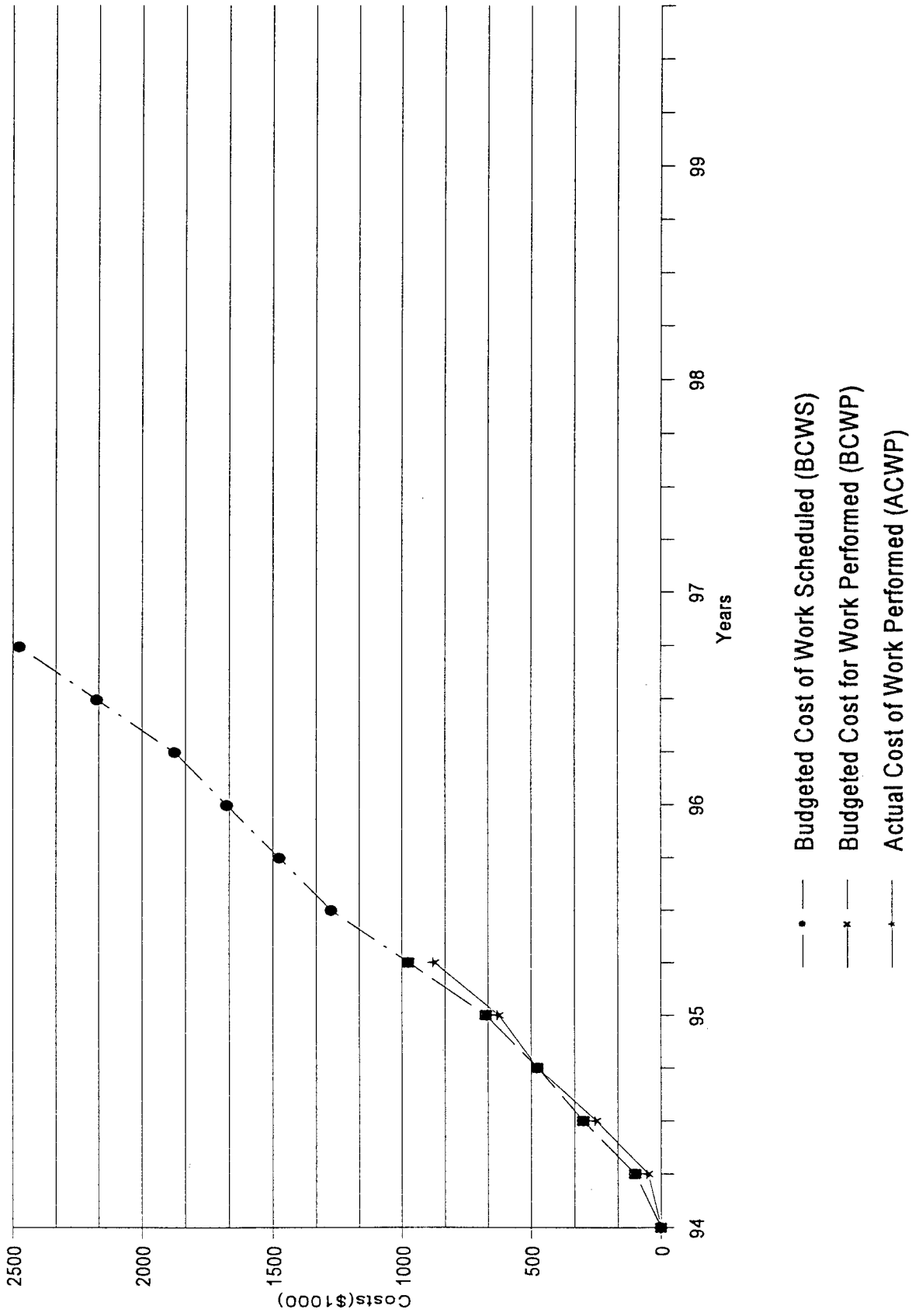

# WCDS Software

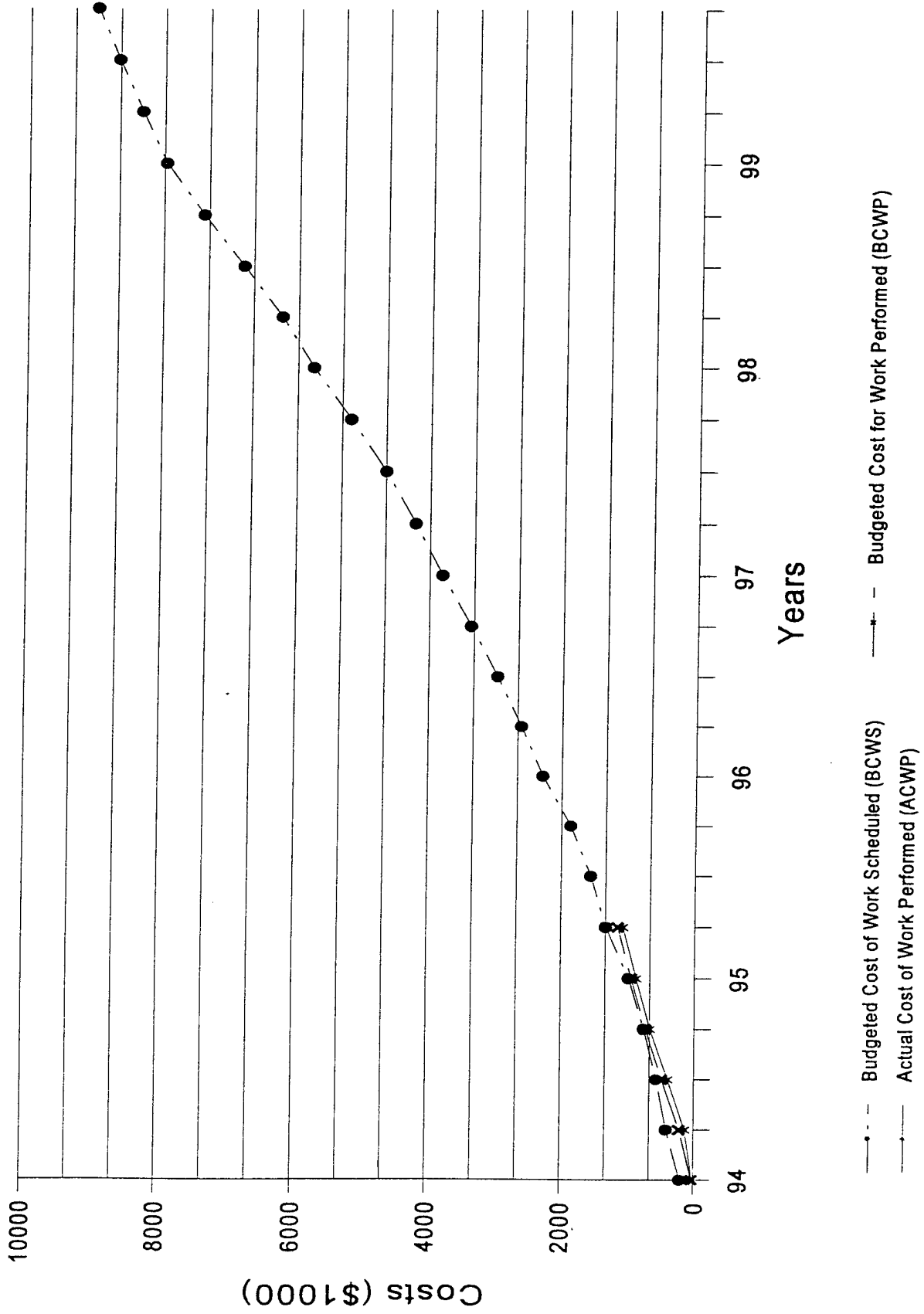

## Chart V

### INTERFACE WITH OTHER SYSTEMS:

#### National Weather Service (NWS)

- 4 - AFOS National NWS Communication Circuits
- 12 - RFC River Forecast Centers
- 48 - WFO Regional NWS Weather Forecast Offices
- 1 - NWS Hydrologic Research Lab
- 1 - National Severe Storms Center
- 1 - National Hurricane Center
- 1 - National Operational Hydrologic Remote Sensing Center

#### NOAA/FAA/DoD NEXRAD Sites

- 133 - WSR-88D Radar Product Generator (RPG)

#### Geostationary Operational Environmental Satellite (GOES)

- 3000 - Data Collection Platforms (DCP) via
- 1 - NOAA NESDIS ADAPS system
- 4 - Corps Ground Receive Sites
- 30 - DOMSAT Receive Sites
- 1 - National Satellite Weather Imagery

#### Land Based Data Acquisition Systems

- 1 - Columbia Basin Telecommunications Network
- \* - Local Flood Warning Systems ALERT/IFLOWS

#### U. S. Geological Survey (USGS)

- 1 - WATSTORE National Water Resources Data
- 1 - EROS Data Center
- 48 - USGS Regional Offices PRIMOS

#### Other Federal

- 1 - Natural Resources Conservation Service SNOTEL
- 4 - Regional US Bureau of Reclamation Offices
- 1 - Tennessee Valley Authority (TVA)

#### Power Systems

- 1 - Southwestern Power Administration
- 1 - Western Power Administration
- 1 - Bonneville Power Administration RODS System
- 1 - New York Power Authority
- \* - Power Plant SCADA Systems
- \* - Private Power Systems

International Systems

- 1 - International Joint Commission (IJC) (Columbia River)
- 1 - IJC International Great Lakes Technical Information Network
- 1 - International Boundary Commission (Rio Grande/Colorado Rivers)
- 3 - British Columbia, Quebec, Ontario Hydro

Regional/State/Local Agencies (interfaces vary depending on Corps and local capabilities/needs)

- \* - State Department of Natural (Water) Resources
- \* - River Basin Commissions
- \* - Flood Control Districts

## Chart VI

### OTHER SYSTEMS (CORPS & NON-CORPS) HAVING SIMILAR CAPABILITY:

#### Corps

- None

#### Non-Corps

Several other organizations have components of real-time water control systems that have similar capability. No other organization has the breadth of multipurpose scope (e.g., flood control, navigation, hydropower, water quality, fisheries, recreation) or geographic coverage (all United States) as the Corps of Engineers.

- National Weather Service

The NWS has similar capability for a portion of the Corps system needs. The root capability to forecast river flows is found in the NWS. The NWS procedures are focused on the development of peak stage and time of occurrence for selected river stations to meet its public warning mission.

- Bureau of Reclamation

The USBR operates reservoirs and reservoir systems in the Western US. Similar needs exist for several project purposes, however, the Corps is responsible for reservoir operations of all Federally funded flood control projects during flood pool stages (Section 7 Federal projects). Primary focus of USBR forecast and reservoir model operations is on water supply and hydropower generation.

- Tennessee Valley Authority

The TVA operates multipurpose reservoir systems within the boundaries of the Tennessee Valley. Several similar capabilities exist in their operational systems. Limited scope to local regional area results in specific solutions to their needs.

- State Resource or River Authorities

Few state resource agencies or river authorities have the capability to operate real time reservoir systems. Most state systems are established for regulatory purposes. California is the most developed in this regard, but project purposes are focused on water supply.

## Chart VII

### PLANNED FUTURE CHANGES/MODIFICATIONS:

- LIFE CYCLE REPLACEMENT OF COMPUTER HARDWARE
- DATA ACQUISITION
  - National Weather Service NEXRAD (WSR88D Radar) Data
  - Integrated data acquisition/communications with National Weather Service
- CORPORATE WATER CONTROL DATA BASE (ORACLE)
- Modeling, FORECASTING, AND SIMULATION SOFTWARE
  - Spatially-based rainfall-runoff forecast model (NEXRAD data source)
  - Other simulation, impact analysis models
  - Mississippi Basin Stage Forecast Model

Program reviews for the Real Time Water Control R&D program are held twice per year - the annual review in the spring and a mid-year review in the fall. The annual review was held 19 - 20 April 1995. In attendance were representatives from HQUSACE (CECW-EH, CECW-OM, CERD-C), the field review group (13 district and division representatives), CEWES and CEWRC-HEC. Program review documentation are appended.