

The Need for a Probabilistic Risk Assessment of the Oil Tanker Industry and a Qualitative Assessment of Oil Tanker Groundings

by

Michael D. Amrozowicz

B.S. Electrical Engineering (High Honors)
University of Florida, 1990

SUBMITTED TO THE DEPARTMENT OF OCEAN ENGINEERING IN PARTIAL
FULFILLMENT OF THE REQUIREMENTS FOR THE DEGREE OF

MASTER OF ENGINEERING:
PROGRAM IN MARINE ENVIRONMENTAL SYSTEMS
AT THE
MASSACHUSETTS INSTITUTE OF TECHNOLOGY

JUNE 1996

©1996 Michael D. Amrozowicz. All rights reserved.

The author hereby grants to MIT permission to reproduce
and to distribute publicly paper and electronic
copies of this thesis document in whole or in part.

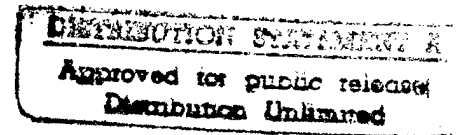

Signature of

Author:

Department of Ocean Engineering
January 28, 1996

Certified

by:

Michael Golay
Professor of Nuclear Engineering
Thesis Advisor

Certified

by:

Alan Brown
Professor of Naval Architecture
Thesis Supervisor

Accepted

by:

Professor A. Douglas Carmichael
Chairman, Committee for Graduate Studies
Department of Ocean Engineering

DTIC QUALITY INSPECTED 3

19961018 044

The Need for a Probabilistic Risk Assessment of the Oil Tanker Industry and a Qualitative Assessment of Oil Tanker Groundings

by

Michael D. Amrozowicz

Submitted to the Department of Ocean Engineering
on January 28, 1995 in Partial Fulfillment of the
Requirements for the Degree Master of Engineering:
Program in Marine Environmental Systems

Abstract

The culture, design, and operation of the maritime industry all contribute to create an error-inducing system. As oil tankers have become larger, the tolerance for error has decreased as the consequences have increased. Highly visible oil spills have made society more aware of the dangers inherent with transporting oil at sea.

A probabilistic risk assessment (PRA) provides a formal process of determining the full range of possible adverse occurrences, probabilities, and expected costs for any undesirable event. A PRA can identify those areas that offer the greatest risk-reducing potential. Once the components with the greatest risk-reducing potential are identified, appropriate technology and management schemes can properly influence risk reduction.

Humans contribute to high consequence accidents in the design, construction and operations phases of an engineering system. While human error is attributed to 80 percent of the marine accidents, a closer look reveals that many accidents attributed to human error are system errors.

An application of a qualitative risk assessment is done for tanker groundings. A fault tree is developed to describe the top event of a tanker grounding. A number of well-known groundings are analyzed to test the utility of the grounding fault tree.

Table of Contents

ABSTRACT	2
TABLE OF CONTENTS	3
LIST OF FIGURES	6
LIST OF TABLES	7
CHAPTER 1 INTRODUCTION	8
1.1 THE NEED FOR AN ASSESSMENT	8
1.2 OUTLINE	11
CHAPTER 2 HISTORY	12
2.1 OIL TANKER HISTORY.....	12
2.2 OIL AND WATER.....	14
2.3 INTERNATIONAL REGULATION HISTORY	16
2.4 DOMESTIC REGULATION	19
2.5 SUMMARY	20
CHAPTER 3 REGULATORY CONSIDERATIONS	22
3.1 THE IMPORTANCE OF PREVENTION	22
3.2 TECHNOLOGY AND THE EFFICIENT FRONTIER.....	23
3.3 THE ROLE OF FUTURE TECHNOLOGY	25
3.4 TECHNOLOGY BASED STRATEGY	26
3.4 THE ROLE OF RISK ASSESSMENT.....	26
CHAPTER 4 PROBABILISTIC RISK ASSESSMENT	28
4.1 THE PROCESS	28
4.2 BAYE'S THEOREM.....	29
4.3 RISK MODEL.....	31
4.4 FAULT TREES	32
4.5 EVENT TREES	33
4.6 SUMMARY	34
CHAPTER 5 HUMAN FAILURE AND ACCIDENTS	35

5.1 THE PREVALENT FACTOR.....	35
5.2 HUMAN FAILURE.....	37
5.3 FAILURE CLASSIFICATION	38
5.4 INDIVIDUAL ERRORS.....	41
5.6 HARDWARE	43
5.5 PROCEDURES	44
5.7 ORGANIZATIONS.....	45
5.8 THE ENVIRONMENT	46
5.9 SUMMARY	46
CHAPTER 6 PLANNING AND PILOTING.....	48
6.1 NAVIGATION CONTROL MODEL.....	48
6.2 NAVIGATION AND PILOTING	50
6.3 VOYAGE PLANNING	51
6.4 SUMMARY	54
CHAPTER 7 DEVELOPING THE FAULT TREE	55
7.1 CLASSIFICATION OF SPILLS.....	55
7.2 GROUNDINGS AS A FIRST ANALYSIS.....	57
7.3 DEVELOPING THE GROUNDING FAULT TREE.....	57
7.4 THE ACTUAL COURSE FOLLOWS AN UNSAFE TRACK.....	60
7.4.1 THE DESIRED TRACK IS AN UNSAFE TRACK.....	60
7.4.2 ACTUAL COURSE DEVIATES FROM A SAFE DESIRED TRACK.....	61
7.4.2.A THE DIFFERENCE ERROR IS RECOGNIZED.....	62
7.4.2.B THE DIFFERENCE ERROR IS NOT RECOGNIZED	63
7.5 SUMMARY OF THE COURSE PROCEEDING DOWN AN UNSAFE TRACK.....	63
7.6 UNABLE TO STEER THE ORDERED COURSE	65
7.6.1 THE SHIP HAS LOST WAY	66
7.6.2 UNSAFE WIND/CURRENT.....	66
7.6.3 ANCHOR FAILURE	66
7.6.4 ASSISTANCE FAILURE.....	67
7.7 SUMMARY OF SHIP UNABLE TO FOLLOW A SAFE TRACK.....	67
7.8 SUMMARY	68
CHAPTER 8 APPLICATIONS.....	71
8.1 VALIDATION.....	71
8.2 THE <i>TORREY CANYON</i>	71

8.3 THE *TRANSHURON*75
8.4 THE *AMOCO CADIZ*.....78
8.5 THE *EXXON VALDEZ*81
8.6 THE *BRAER*85
8.7 FAULT TREE UTILITY88
CHAPTER 9 CONCLUSION89
9.1 THE NEXT STEP89
9.2 *CAVEAT EMPTOR*.....90
9.3 *PRÉCIS*91
BIBLIOGRAPHY93

List Of Figures

FIGURE 1 - 1: WORLD SEABORNE TRADE BY TYPES OF CARGO	10
FIGURE 3 - 1: PYRAMID OF SAFETY FOR TRANSPORT OF OIL AT SEA.....	23
FIGURE 3 - 2: THE EFFICIENT FRONTIER FOR RISK REDUCTION COMPLIANCE	24
FIGURE 3 - 3: INNOVATIVE RESPONSE TO REGULATION	25
FIGURE 4 - 1: BASIC TASKS.....	29
FIGURE 4 - 2: VENN DIAGRAM	30
FIGURE 4 - 3: RISK MODEL	31
FIGURE 4 - 4: AND AND OR GATES.....	32
FIGURE 4 - 5: EVENT TREE	34
FIGURE 5 - 1: CONTEXT OF HUMAN FAILURES AND INDIVIDUAL ERRORS	37
FIGURE 5 - 2: CLASSIFICATION OF HUMAN FAILURE	40
FIGURE 5 - 3: EMBREY'S TAXONOMIC SYSTEM	44
FIGURE 6 - 1: NAVIGATION CONTROL MODEL	49
FIGURE 7 - 1: MAJOR OIL SPILLS FROM TANKERS AND CAUSES - 1976 TO 1989.....	56
FIGURE 7 - 2: BASIC ACCIDENTAL OIL OUTFLOW FAULT TREE	56
FIGURE 7 - 3: BASIC GROUNDING FAULT TREE	58
FIGURE 7 - 4: GROUNDING FAULT TREE	59
FIGURE 7 - 5: FAULT TREE FOR ACTUAL COURSE PROCEEDING DOWN AN UNSAFE TRACK.....	64
FIGURE 7 - 6: PARTIAL FAULT TREE FOR THE INABILITY TO STEER THE ORDERED COURSE	65
FIGURE 7 - 7: FAULT TREE FOR SHIP UNABLE TO FOLLOW A SAFE TRACK.....	68
FIGURE 7 - 8: GROUNDING FAULT TREE	70
FIGURE 8 - 1: FAULT TREE FOR <i>TORREY CANYON</i> GROUNDING	74
FIGURE 8 - 2: FAULT TREE FOR <i>TRANSHURON</i> GROUNDING	78
FIGURE 8 - 3: FAULT TREE FOR THE GROUNDING OF THE <i>AMOCO CADIZ</i>	81
FIGURE 8 - 4: FAULT TREE FOR THE GROUNDING OF THE <i>EXXON VALDEZ</i>	84
FIGURE 8 - 5: FAULT TREE FOR THE <i>BRAER</i> GROUNDING.....	87

List of Tables

TABLE 1 - 1: INPUT OF PETROLEUM INTO THE MARINE ENVIRONMENT - 1985 ESTIMATES	9
TABLE 1 - 2: OIL TANKER ISSUES ASSOCIATED WITH MINIMIZING POLLUTION.....	10
TABLE 2 - 1: U.S. TANKER SPILLS EXCEEDING 1 MILLION GALLONS 1976-1989	15
TABLE 5 - 1: FACTORS CONTRIBUTING TO MARINE CASUALTIES	36
TABLE 5 - 2: CATEGORIES OF INDIVIDUAL ERRORS	41
TABLE 5 - 3: INDIVIDUAL ERROR FACTORS.....	41
TABLE 9 - 1: TASKS REQUIRED TO PERFORM A PRA OF THE OIL TANKER INDUSTRY.....	89
TABLE 9 - 2: HUMAN RELIABILITY ANALYSIS MODELS	90

Chapter 1 Introduction

1.1 The Need for an Assessment

Operating on the ocean inherently involves a risk environment that differs significantly from what the majority of people encounter on a daily basis. Mariners are familiar with these risks in practical terms, but there are no practical means for mariners to fully assess all the factors that could affect safety [48]. Accepting these risks is considered a tradition of the sea [53]. Risk management for the mariner often depends upon his or her perception of the risk at hand, and a personal judgment of how to react to that risk. Thus, symptoms rather than causes are often treated [48].

Until recently, the environmental risks of transporting large quantities of hazardous material have been seemingly underestimated or ignored. While the recent accidents of the *Exxon Valdez* and the *Braer* have rallied public outcries, the political and legislative response has been typified as reactive. Despite restructuring, the regulatory framework's efficacy remains questionable.

It is estimated that 3.3 million tons of petroleum hydrocarbons enter the marine environment annually (Table 1-1) [47]. The maritime industry, mostly tankers, contributes forty-five percent of the pollution.

Table 1 - 1: Input of Petroleum into the Marine Environment - 1985 Estimates

<u>Source</u>	<u>Best Estimated Input</u> (million tons per year)	
Natural sources		0.25
Offshore Production		0.05
Maritime Transportation		
Tanker Operation	0.70	
Tanker Accidents	0.40	
Other	0.40	1.5
Atmospheric Pollution Carried to Sea		0.3
Municipal and Industrial Wastes and Runoff		1.18
Total		3.3

In 1992, oil tankers carried 1,850 million tons of cargoes representing nearly 44 percent of all the seaborne trade [63]. As the United States and other member countries of the Organization for Economic Cooperation and Development (OECD) continue to decline in domestic oil production, it is expected that their import dependence will rise from 58 percent in 1992 to 70 percent by 2010 [63]. The demand for oil in the rest of the world is expected to rise even faster, doubling by 2010 [63]. With the projected increases in oil demand, and the Organization of Petroleum Exporting Countries (OPEC) the likely source, tanker demand will increase as the world's dependence on OPEC increases. While the amount of petroleum pollution compared to the amount of petroleum transported at sea is very small, with more tankers delivering more oil, it is likely that marine oil pollution will increase. To minimize the amount of petroleum hydrocarbons entering the oceans from the tanker industry, a thorough evaluation of the entire industry must be done to incorporate effective improvements. Recent studies have shown that operational oil pollution, contributed by tankers, has been reduced by 78 percent [27], however, spills from accidents vary enormously from year to year.

The petroleum industry contributed over 8 trillion ton-miles to the world's seaborne trade in 1992 [63]. The transportation of crude oil and petroleum products represent the largest single contribution to seaborne trade (Figure 1-1)[63]. Because the movement of oil is the foundation of the industry's structure, slowing the movement of oil would slow the

movement of cash.

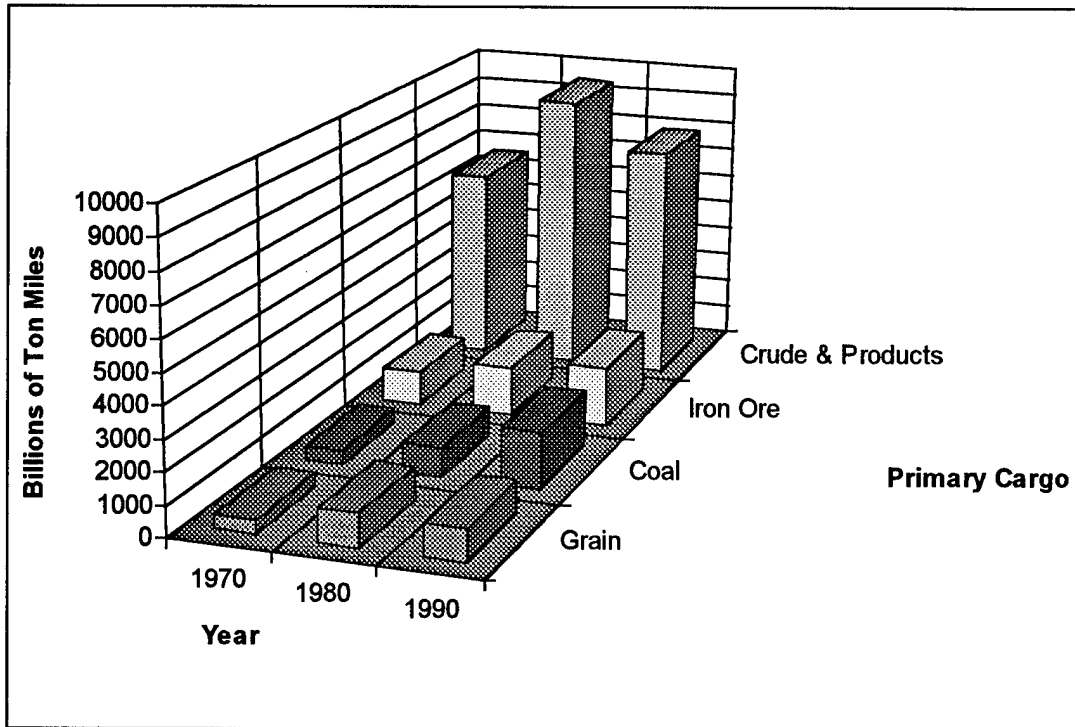

Figure 1 - 1: World Seaborne Trade by Types of Cargo

There is some evidence to link tanker age to serious casualties [47]. The world's tanker fleet continues to age--the average tanker age in 1992 was 16.72 years [63]. With most of the world's oil moved by ship, the expected demand on an aging fleet can conceivably lead to more accidents.

There are a number of issues outlined in Table 1-2 confronting the oil tanker industry as to how to best minimize pollution. These issues cannot be properly addressed until there is a thorough understanding of all the risks involved with transporting oil at sea.

Table 1 - 2: Oil Tanker Issues Associated With Minimizing Pollution

Port Control	Crew Rotation	Machinery Redundancy	Liability
Flag State Control	Crew Training	Structural Integrity	Economics
Vessel Traffic	Crew Licensing	Automation	Salvage
	Crew Size	Navigation Systems	Law of the Sea
	Pilot-Navigator	Communication	

Perrow has called the maritime industry an “error-inducing” system [53]. “The configuration of its many components induces errors and defeats attempts at error reduction” [53]. Discrete attempts at correcting the system will be defeated by something else in the system. Once the risks are understood, and consideration is made of all the issues, the components of the system, and their synergism, the proper regulatory framework can be developed which addresses a wholesale solution rather than discrete problems. The result can be an error-neutral, or an error-avoiding system.

1.2 Outline

This thesis begins by showing that there is a need for a total systems approach to risk and risk management in the oil tanker industry. Chapter 2 offers a brief history of the oil tanker industry and the regulation thereof. Subsequently, in Chapter 3, regulatory considerations are presented which allow for innovation while minimizing the risk of pollution. Chapter 4 then presents the paradigm to follow for a complete risk assessment. Given that a large percentage of marine accidents are attributed to human error, Chapter 5 explores the causes and classifies human error. Since proper piloting and navigation are so fundamental to a safe voyage, Chapter 6 offers the introductory concepts of piloting and navigating a ship. The first step of a PRA is to identify the system failures and sequences. In Chapter 7, a fault tree for oil tanker groundings is developed to identify system failures and sequences. To show the utility of the fault tree, some well-documented tanker groundings are undertaken as case studies in Chapter 8. Finally, the conclusions and recommendations are presented in Chapter 9.

Chapter 2 History

2.1 Oil Tanker History

The first commercial oil well was established in 1859 in Titusville, Pennsylvania. Pennsylvania crude was shipped from wells to refineries in wooden barrels to make kerosene. The first transatlantic shipment of petroleum, conducted in 1861, is attributed to the 224-ton *Elizbeth Watts*, a two-masted, square-rigged sailing vessel. As shipments began to increase, the disadvantages of shipping petroleum in wooden barrels led to the use of 5 gallon tins [56]. But the expense of tins gave way to the obvious solution of shipping in bulk.

The *Atlantic* was launched in 1863 as the first ship designed to carry oil in bulk [62]. An iron sailing ship, the *Atlantic* and all following tankships used the hull as the container for the cargo. In 1885, 99 percent of American oil exports were still carried in barrels. The complete transition of the marine petroleum transportation industry to a bulk system occurred after the launching of *Gluckauf*, in 1886. Displacing approximately 3,000 dead weight tons (dwt), the *Gluckauf* was the first ship to have the essential features of a modern tanker. By 1906, 99 percent of American oil exports was carried in bulk tankers [37].

By 1921, the world tanker fleet had grown to 7 million dwt [37]. As the fleet had grown, so had the size of each ship. During World War II, the demand for petroleum far exceeded the capabilities of the pre-war fleet. Therefore, the U.S. built 532 tankers of the T-2 class that displaced 16,600 dwt. After the war, oil companies began to recognize the profits from economies of scale. In 1949, ships in the 27,000 dwt range were considered supertankers.

The incredible post-war economic growth, fueled by oil, made it profitable to build local refineries, thereby giving new importance to the shipment of crude oil. By the mid 1960's, more than half the world's seaborne cargo consisted of crude or refined petroleum [11].

In 1956, Egypt took control of the Suez Canal, and closed it. The ramifications of closing the vital passage, used by tankers to carry oil to Europe, spawned owners to build bigger ships to make the passage around the Cape of Good Hope. In 1957, the largest tanker was 57,000 dwt. In 1966 the first supertanker was launched, displacing 210,000 dwt. By the mid seventies, ships were being built in the 500,000 dwt range and the 1,000,000 dwt tanker was on the drawing board.

As tankers became larger, the potential damage they could impose upon the environment increased. Limitations on tanker size had been imposed by operational and economic factors,¹ rather than technical constraints. Yet, the effects of spills from the likes of the *Torrey Canyon*, and the *Amoco Cadiz*, have allowed public opinion to limit the size of tankers.² Considering the more recent *Exxon Valdez* accident, it is unlikely that future tanker size will ever exceed 500,000 dwt.

Currently, the world's tanker fleet is over 263 million dwt [63], with over 6000 tankers sailing the oceans [47]. Of the world's merchant fleet, tankers represent the oldest type of vessel. The average age of a tanker is 16.72 years with 62 percent of the tankers being built more than 15 years ago [63], and 27 percent more than 25 years old [50]. With an aging fleet serving a world economy thirsty for oil, the potential for disaster remains greater than ever.

¹ In the last 25 years, the transportation costs of oil have decreased from approximately 50 to 10 percent of the delivered price. Therefore, there is less incentive to build larger tankers, especially with the increasing role of liability.

² The state of Washington limits tankers operating in its waters to 125,000 dwt.

2.2 Oil and Water

Oil is an amalgam of thousands of chemicals, and each chemical affects the marine environment in a different way [17]. The environment itself lends uncertainty into any chemical's effect. Wind, waves, current, temperature, and sunlight, all affect the ability of the oil to disperse, dissolve, and biodegrade [17].

Ever since ships began transporting petroleum products there was pollution of the seas. Barrels used in the 19th century would typically lose between 5 and 12 percent of their contents [56]. Not only did the leaky barrels cause pollution, but when loaded on a ship, the vapors could turn the ship into a floating bomb. A number of the ships used in the 19th century to transport oil, left port never to be seen again.

It was not until the 20th century that concerns for pollution began to be voiced. As Table 1-1 shows, tanker operation accounts for nearly 1.1 million tons of petroleum pollution annually. Most of the pollution comes from operations such as loading, unloading, ballasting, etc. In 1964, the major oil companies decided on steps to reduce and remove all unwanted effects from discharging oil contaminated water by introducing the load-on-top technique.[58]³

Although numerous, operational spills are typically small, and isolated from the public. It was the *Torrey Canyon* spill, in March of 1967, which opened the modern world's eyes to the potential damage to be offered by the transporting of large quantities of oil. The *Torrey Canyon* accident was the first oil spill to receive such widespread publicity.

As tankers grew in size, new problems were encountered. In December of 1969, three large tankers exploded while cleaning the tanks: the *Marpessa*, *Mactra*, and *Kong Haakan VII*. It was discovered that high velocity water, used to clean the tanks, created

³ It is estimated that 0.2 to 0.5 percent of a tanker's cargo remains on board in the form of residue after discharge [58]. For a 250,000 dwt tanker, this represents 1,250 tons of residue which previously would have been washed over the side. The load-on-top technique is a method of ballasting. Simply described, after a tanker discharges its cargo, its tanks are cleaned and filled with ballast. The tanks settle with time and the water which has separated to the bottom is pumped overboard and the oil residues are then pumped to a slop tank to be retained and intermingled with the next cargo. Literally, loaded on top of the residues.

enough static electricity to ignite the fumes in the tanks. These catastrophes led to the inert gas systems⁴, and crude oil washing⁵, now employed on all large tankers.

The 1970's provided more examples of the hazards offered by tankers. In 1976 alone, 19 tankers went aground, exploded, or sank. The 1970's culminated with the worst tanker accident ever--the collision of the two supertankers *Atlantic Empress* and *Aegan Captain* off the coast of Tobago.

The U.S. has not been spared from its share of tanker accidents. Table 2-1 [49] shows a list of tanker oil spills exceeding 1 million gallons that occurred in U.S. waters from 1976 to 1989. Even though all the spills were significant in terms of the amount, the spills between the *Argo Merchant* and the *Exxon Valdez* either did not occur in an area considered environmentally sensitive, or they were not sufficiently spectacular to invigorate the media to evoke a widespread public response.

Table 2 - 1: U.S. Tanker Spills Exceeding 1 Million gallons 1976-1989

DATE	SOURCE	LOCATION	MILLION GALLONS SPILLED	CAUSE
3-24-89	<i>Exxon Valdez</i>	Prince William Sound, Alaska	10.8	grounding
10-31-84	<i>Puerto Rican</i>	off San Francisco, California	2.0	explosion/fire
7-30-84	<i>Alvenus</i>	off Cameron, Louisiana	2.8	grounding
3-31-82	<i>Arkas</i>	Montz, Louisiana	1.47	collision/fire
1-28-81	<i>Olympic Glory</i>	Galveston Bay, Texas	1.0	collision
11-22-80	<i>Georgia</i>	Pilottown, Louisiana	1.3	holed by anchor chain
11-1-79	<i>Burmah Agate</i>	Galveston Bay, Texas	10.7	collision/fire/explosion
12-15-76	<i>Argo Merchant</i>	off southeastern Massachusetts	7.6	grounding

⁴ Petroleum vapors are flammable for a small range of air/vapor mixtures. The object of an inert gas system is to reduce the oxygen level in the tank atmosphere by replacing it with some other gas. This is accomplished by either using the flue gasses from the boilers or utilizing a separate inert gas generator.

⁵ Crude oil washing employs the cargo itself to wash the tanks. It has been shown to leave less residue and clean the tanks better than water. The electro-static charge generated by washing with crude oil is significantly less than that of water. However, if there is water in the oil, the generated electro-static charge can be greater. Therefore, crude oil washing must be employed with inert gas systems.

2.3 International Regulation History

Marine pollution from tankers is generally put into two categories:

1. Operational: discharges which occur during loading/unloading, ballasting, and tank cleaning.
2. Accidental: spills resulting from a tanker casualty.

With "Freedom of the Seas" as a first principle, making the oceans common property, it has been necessary to address marine pollution on an international level. Hence, various international agencies, conventions, and conferences have emerged to address both operational and accidental spills to varying degrees.

General concern for oil pollution began in the 1920's when pollution was addressed at the International Maritime Conference in Washington, D.C.. Despite issues being addressed in both technical and legal terms, the convention failed to be ratified by any nation [51].

During World War II, nearly 20 million barrels of oil spilled into the Atlantic Ocean as a consequence of war. With the lingering pollution of the war, the increase in petroleum demand, and continued discharges of oil into the sea, there was another attempt to attack the problem at an international level. In 1954, the International Convention on the Prevention of Oil Pollution met with the premise to prohibit the intentional discharge of oil and oily mixtures. Under this Convention, and subsequent amendments, a system of zonal controls was created, prohibiting discharges within 50 miles of the coast, and otherwise limited dirty ballast discharges to a proscribed rate[9].

In 1958, the United Nations held the first Conference on the Law of the Sea (UNCLOS I) and formed the Intergovernmental Maritime Consultative Organizations (IMCO), now known as the International Maritime Organization (IMO). The IMO has become the primary force behind international maritime issues. UNCLOS I resulted in two conventions which addressed pollution. Issues of coastal state's rights versus freedom of the seas began to emerge regarding pollution. The Convention on the High Seas attempted to temper the controversy by calling on all nations to cooperate with international organizations

to prevent pollution of the seas [65]. The second convention, the Convention on the Territorial Sea and the Contiguous Zones, declared coastal state's rights in the 12 mile territorial waters. But the language was broad and it did not specifically address oil pollution, liability, and damages.

In 1967, when the *Torrey Canyon* spilled nearly 120,000 tons of crude oil off the southwest coast of England, the reality of the hazards involved with transporting oil came to light. Issues involving the coastal states' right to take preventive action on the high seas to protect its shores contradicted with the traditional "freedom of the sea's" philosophy. The International Convention Relating to Intervention on the High Seas in Cases of Oil Pollution Casualties, in 1969, provided coastal states with emergency response power beyond territorial waters in order to prevent, mitigate, or eliminate grave and imminent danger to the marine environment when there was an expectation of major harmful consequences [65].

The *Torrey Canyon* spill became a catalyst for issues of liability. The 1969 International Convention on Civil Liability for Oil Pollution Damage provides a legal basis for claims of damages to a state's territorial sea or coast. The convention imposes strict liability on the ship owner and requires vessels to have certificates of financial responsibility (COFR) to the liability limits [9]. The liability limit of the convention was placed at \$18 million. The 1971 International Convention on the Establishment of an International Fund for Compensation for Oil Pollution Damage was intended to supplement the inadequate liability limits, raising the limit to \$79 million.

As a result of the *Torrey Canyon* spill, the IMCO took a more comprehensive approach to oil pollution and adopted the 1973 International Convention for the Prevention of Pollution from Ships (MARPOL). But a series of groundings, collisions, and explosions between 1974 and 1977 resulted in a number of coastal states demanding another conference, leading to the subsequent 1978 Protocol (MARPOL 73/78). MARPOL 73/78 supersedes the 1954 convention and addresses pollution more comprehensively with both operational and technological requirements. Operational discharges are excluded within 50 miles of land and within special areas. Outside of these exclusion zones, discharges are limited to proscribed amounts achievable by either load on top or shore discharge facilities. Machinery space bilges are required to have monitoring equipment to control effluent. Additionally,

MARPOL 73/78 provides technical requirements for the design and construction of oil tankers including segregated ballast tanks, crude oil washing systems gas inerting systems, retrofitting schemes, steering equipment, and navigational aids.

The apparent effectiveness of the conferences seemed questionable, when within one month of the 1978 conference, the *Amoco Cadiz* grounded and spilled over 200,000 tons of Iranian crude off the coast of France. In spite of the spill, MARPOL 73/78 remained as the principle international regulatory document addressing maritime pollution.

Despite the advances made by MARPOL 73/78 to prevent pollution, it left the responsibility of enforcement with the country in which the vessel was registered (flag state). With a trend of ship owners registering under flags of convenience, there was little economic incentive for these third-world flags to engage in a vigorous enforcement effort against its ships in distant waters [9]. UNCLOS III was designed to increase port state authority and extend limited authority over foreign vessels in the exclusive economic zone (EEZ).⁶

The IMO has typically approached marine safety from a technical perspective [65], but the awareness of the role that human factors have in the steady occurrence of marine casualties has led to different approach. In November 1993, the IMO adopted Resolution A.741(18) -- the *International Safety Management Code* (ISM Code). The ISM Code addresses shipboard and shore-based management for the safe operation of ships, and the prevention of pollution. The focus of the ISM Code is on a management system. The ISM Code encourages those responsible for the operation of ships to take appropriate steps to develop, implement, and assess safety and pollution prevention management [25].

⁶ The EEZ, defined by UNCLOS, defines management and ownership of resources out to 200 miles from the shoreline.

2.4 Domestic Regulation

The pattern of domestic regulation addressing oil pollution parallels that of the international community but it is often not in union. With concerns of oil pollution at the turn of the century, in 1926, the U.S. legislated the Pollution of the Sea by Oil Act [62].

At the time of the *Torrey Canyon* spill, the Limitation of Vessel Owner's Liability Act of 1851 (1851 Act) was still in force in the U.S.. The 1851 Act was intended to promote commerce and shipping by limiting a shipowner's potential liability. The 1851 act limited the liability of an owner to the value of the vessel after the incident plus any money the vessel owner had earned during the voyage in with the incident occurred. In the case of the *Torrey Canyon*, (which had claims of \$153 million in 1992 dollars), liability in the U.S. was limited to \$50 -- the value of the remaining lifeboat [64].

Since the *Torrey Canyon* spill, the U.S. Congress has made efforts to ensure equitable liability. The Congress never adopted the 1969 and 1971 liability conventions, and instead chose to take a unilateral step toward a resolution of financial responsibility by enacting the Federal Water Pollution Control Act (FWPCA).

The FWPCA superseded the 1851 Act, with respect to pollution, by establishing liability limits and requiring COFR's to assure clean-up compensation. In this unilateral action, the U.S. became the first country to require COFR's. The COFR's were required four years before the 1969 CLC entered into force.

After FWPCA, Congress took a fragmented approach by enacting a series of directed legislation. Each act mandating larger and more comprehensive financial responsibility for vessels involved in the respective act's coverage:

1. Trans-Alaska Pipeline Authorization Act of 1973.
2. Deepwater Port Act of 1974.
3. Outer Continental Shelf Lands Act Amendments of 1978.
4. Comprehensive Environmental Response, Compensation, and Liability Act of 1980.

The U.S. did depart from its unilateral action by implementing MARPOL 73/78 as the Act to Prevent Pollution from Ships in 1980. But when the *Exxon Valdez* ran aground 1989, Congress took swift and unilateral action to modernize the liability laws, rejecting the international approach.

When the *Exxon Valdez* spilled 40,000 tons of oil, there was an incredible public reaction. It was the *Exxon Valdez* spill that coalesced American public opinion about the need for immediate protection of the environment from oil tankers [60]. The subsequent congressional debate and legislation resulted in the Oil Pollution Act of 1990 (OPA 90).

The unilateral action of OPA 90 is far-reaching, and it has been described as “one of the most comprehensive protectionist laws we have ever seen” [61]. A large number of vessels doing business in the U.S. are foreign flagged. By imposing strict liability, allowing states to impose unlimited liability, raising the amount of required financial responsibility, and imposing double hull technology, it is probably the most broad-reaching piece of environmental legislation ever to be signed into law in the United States and in the world [60].

OPA 90 was intended to address oil spills with stronger measures in terms of prevention, response, and liability. And while those topics won broad support throughout the negotiations, it is the method of implementation that has generated the criticisms of OPA 90.

2.5 Summary

Once oil enters the ocean, it is acted upon by a wide variety of processes. The short term effects of a spill can be extremely harmful to the environment. The long term effects of oil, and its myriad constituents are still unknown. Clearly, some areas are more susceptible than others--low energy coastal environments appear to be particularly vulnerable [17]. Experience seems to indicate that recovery times are about 10 to 20 years. Regardless of the impact, it is a preventable man-made perturbation of the environment which stresses the ecosystem unnecessarily.

After the Alaskan pipeline was completed, there were over 8,700 tanker transits of Prince William Sound without incident [13]. Complacency on behalf of all the parties involved, including the public, contributed to the *Exxon Valdez* disaster. To prevent spills, complacency must be prevented. To prevent complacency, one must continually remember that major spills will happen, and when they do, they cannot be controlled.

Knowing that spills are inevitable, there must be a concerted effort to minimize those spills. International and domestic regulatory bodies, in conjunction with oil companies and tanker owners, have made significant strides to minimize the amount of oil pollution from tankers. But the progress gained has been typically reactive. To minimize oil pollution, all parties must thoroughly understand all of the elements of prevention.

Chapter 3 Regulatory Considerations

3.1 The Importance of Prevention

The economic burden of regulation assumes to yield a safety benefit. When charter rates go down, operating margins suffer, and expense reduction becomes critical to the ship owners. As a result, maintenance is deferred, planning is short-sighted, and owners assume more risk to stay afloat [22]. Ultimately, safety suffers and the risk of an accident and subsequent undesirable consequences to the crew, ship, and environment increases.

The primary motivation to prevent tanker accidents, is to minimize oil outflow to the environment. Of course, efforts to prevent oil spills, benefit crew and ship safety. It is assumed that the goal of safe transportation is zero oil outflow. With this in mind, Figure 3-1 [51] defines a pyramid of safety for oil transport at sea. The apex represents mitigative measures. The middle of the pyramid represents measures that minimize pollution after an accident occurs. The base of the pyramid represents those measures that can prevent accidents from happening in the first place.

“Accidents are actions, or inactions, that result in unanticipated and undesirable compromises in quality and safety” [43]. There needs to be more focus on improving quality and safety in the petroleum transportation industry and prevention needs to be the primary concern. While prevention is complex and difficult to measure, efficacy can only be determined when there is an understanding of all the variables that create accidents. The focus is the responsibility of naval architects, ship owners, operators and regulators.

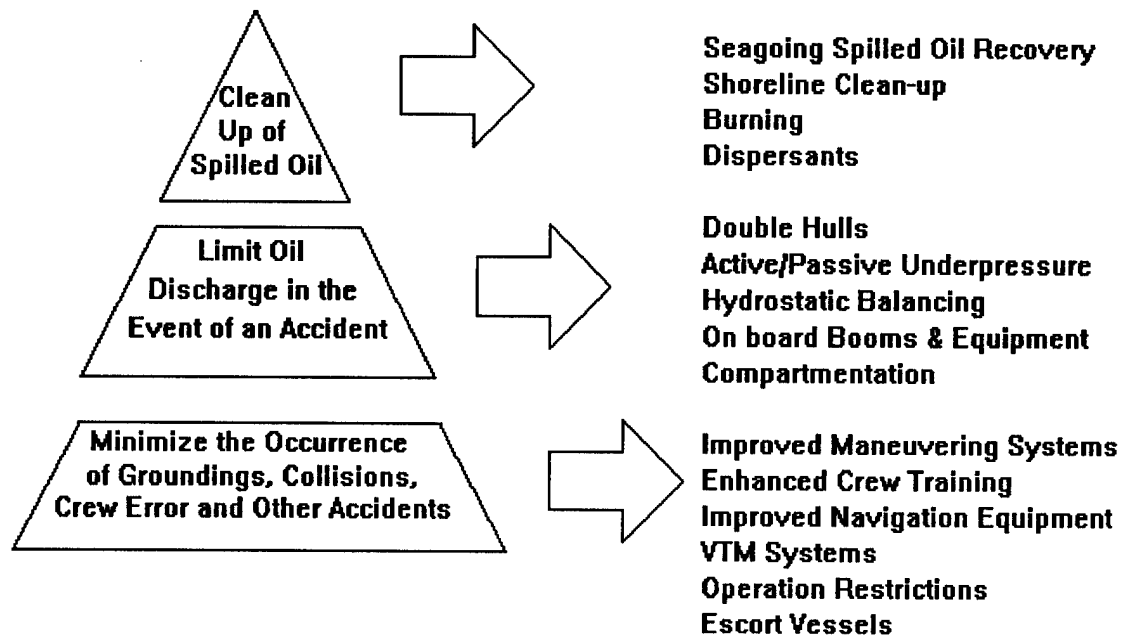

Figure 3 - 1: Pyramid of Safety for Transport of Oil at Sea

3.2 Technology and the Efficient Frontier

Technological change is regarded as essential to advances in pollution reduction [1]. Technology can be defined as the body of tools, machines, materials, techniques and processes used to produce goods and services and satisfy human needs.⁷ For an industry to change its technology it must have willingness, capacity, and opportunity. While attitudes affect willingness, and knowledge affects capacity, the regulatory framework often provides the opportunity [1]. But measuring opportunity must not be limited to existing technology,

⁷Thorndike-Barnhart Dictionary, Scott Foresman and Co., 1967.

since this does not present the true risk-reducing potential provided by technological innovation.

Consider Figure 3-2, a plot of the costs per unit of risk reduction facing the producer/operator. The curves represent the marginal costs for the reduction of risk using the spectrum of available technologies. The curve for the optimum technology available represents the lowest cost approach to achieving risk reduction. This curve is the efficient frontier that should form the basis for risk reduction regulation.

While Figure 3-2 shows how the efficient frontier compares to other technology, it lacks vision in terms of future innovation. To consider the possibilities of technological advances, a more dynamic approach must be taken.

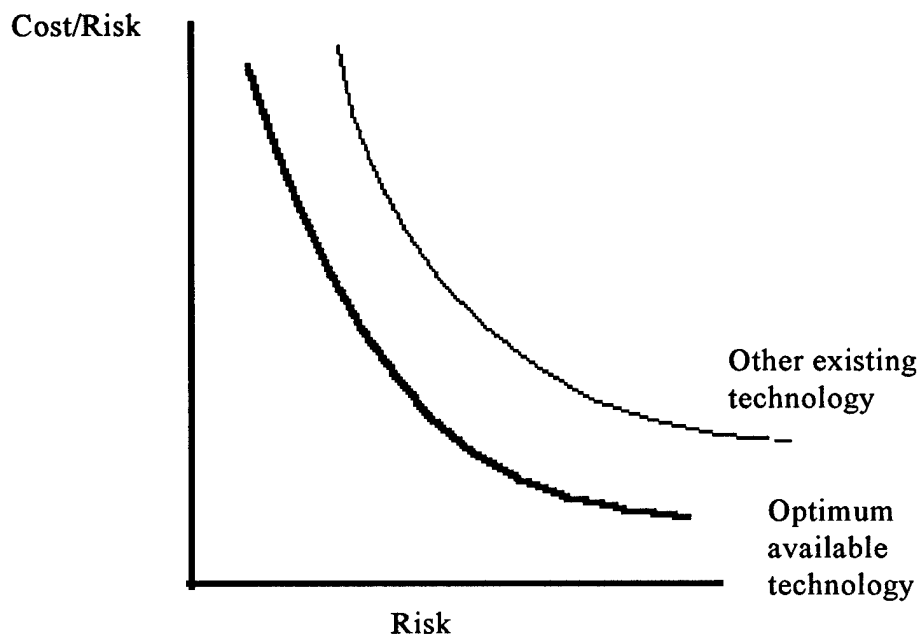

Figure 3 - 2: The Efficient Frontier for Risk Reduction Compliance

3.3 The Role of Future Technology

Continuing with a more dynamic economic approach, refer to Figure 3-3. Let the pre-regulatory level of risk be represented by R_0 . Societal demand for risk reduction requires regulations to impose a maximum allowable risk that is significantly lower. Suppose that public demand requires that regulation impose a reduction in risk from R_0 to R_1 . The best existing technology imposes a cost represented by point B. If it were possible to stimulate innovation, a new curve might be generated which could allow the same degree of risk reduction at a lower cost: the difference between points B and C. On the other hand, for the same cost, a lower risk is achievable (point D).

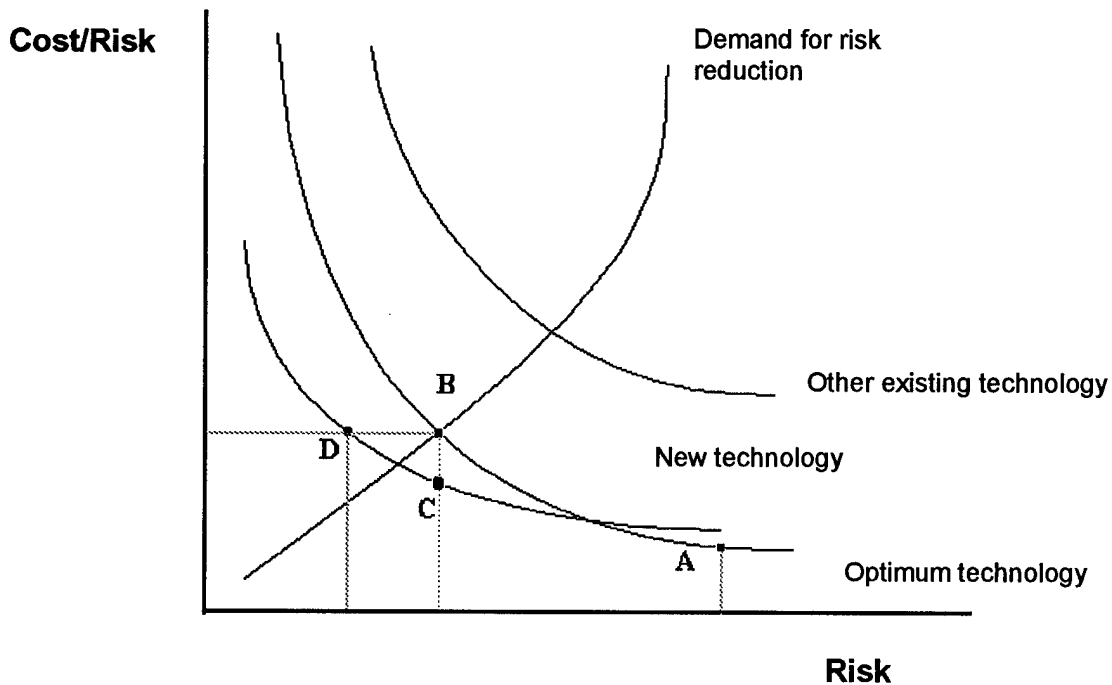

Figure 3 - 3: Innovative Response to Regulation

Mandating double-hulls, as a passive oil outflow prevention measure, imposes a technology-based standard on the industry. While mandating double hulls will minimize oil pol-

lution for some groundings and collisions, it may not be the optimum technology, and it impedes innovation of other technologies which may be more effective.

3.4 Technology Based Strategy

There needs to be a regulatory structure which effectively addresses pollution prevention and mitigation while minimizing any unnecessary economic burdens and innovation impediments. Therefore, a broader technology-based strategy rather than a technology based standard must be implemented. A technology-based strategy focuses on expanding the technological options for reducing or eliminating the risks associated with transporting oil at sea [1]. It also encourages safety development rather than restricting safety to a set of boundary conditions imposed by a mandated technology.

Once the components with the greatest risk-reducing potential are identified, they can be addressed through one or all of the following:

1. An appropriate combination of efficient engineering systems and equipment.
2. Efficient management systems and procedures.
3. A practical understanding of people and other human factors.

3.4 The Role of Risk Assessment

Traditionally, formal risk analysis is divided into two parts [24]:

1. risk assessment: which seeks to identify hazards and calculate their expected adverse effects.
2. risk management: which seeks to structure decision-making on the acceptability of risks and on the measures society might employ against unacceptable risks.

Society demands that risk not exceed a certain level based upon cost per unit risk and the consequences. The integrated systems approach to risk assessment and risk management should be undertaken to determine and manage tanker industry risks. Once high risk compo-

nents are identified, they can be prioritized not only by their risk, by their potential for risk reduction. Regulators can then systematically influence risk levels to society's demand without compromising their regulatory responsibility and minimizing the regulatory burden placed upon the ship owners.

Chapter 4 Probabilistic Risk Assessment

4.1 The Process

A probabilistic risk assessment (PRA) provides a formal process of determining the full range of possible adverse occurrences, and values to be assigned to their probabilities and expected costs, for any undesirable event. There are numerous undesirable events that can be characterized in the maritime industry. As Table 1-1 shows, the majority of oil pollution from the maritime industry is from oil tankers. Although tanker accidents may only represent 12 percent of the annual oil pollution to the marine environment, compared to 21 percent due to operational oil pollution [47], operational pollution is better understood, more deterministic, and is actively being reduced. A more recent estimate of oil discharged into the marine environment from tanker operations suggests that a 78 percent decrease from the 1985 estimate in Table 1-1 [27].

There are numerous accidents that receive inadequate investigation, and an unknown number of accidents that are not reported [30]. Statistically, for every maritime accident, there are 400 near misses [6]. While serious accidents typically evoke intense public scrutiny and contribute valuable insight into causality, the tendency is to elicit a reactive and symptomatic response. The results too often address the worst-case scenario, and ignore the most-likely incident [32]. Hence, there is a fundamental lack of understanding as to how and why accidents occur and this PRA will focus on accidents.

To undertake a complete PRA, tasks must be defined so that the process proceeds systematically. Rasmussen defined the essential tasks of a PRA in his safety study of the nu-

clear power industry [66]. Modifying Rasmussen's approach, the required tasks necessary to perform an assessment of the oil tanker industry are as follows [55]:

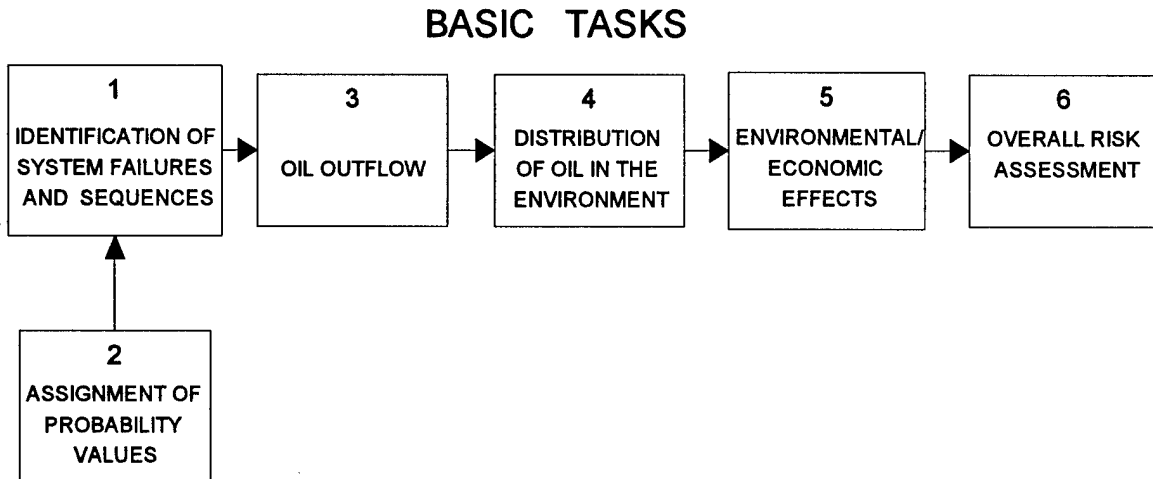

Figure 4 - 1: Basic Tasks

Task 1: Identifies the combination of system failures which can lead to an accident.

Task 2: Determines the probability of each failure.

Task 3: Yields the probability distribution of oil outflow for each failure.

Task 4: Determines the transport and fate of the released oil for the prevailing weather conditions.

Task 5: Assesses the economic and environmental effects.

Task 6: Provides an overall risk assessment for each of the failure sequences identified.

4.2 Baye's Theorem

The outcome of this PRA is the economic and environmental impact of an oil spill. Given the series of tasks outlined to perform a PRA, it is conceptually easier to break the tasking into a set of functional levels. The occurrence of an oil spill is dependent upon a number of events. Probabilities of dependent events can be evaluated using Baye's theorem:

For two events A and B,

$P(A)$ = the probability of event A.

$P(B)$ = the probability of event B.

$P(A/B)$ = the probability of event A given the occurrence of event B.

$P(B/A)$ = the probability of event B given the occurrence of event A.

$P(AB)$ = the probability of event A and B.

Utilizing set theory, $P(AB)$ is the intersection of the two events:

$P(B/A)$ is concerned with the darkened part of Figure 5 and is the ratio of the area

(AB) to the total area A, that is:

$$P(B/A) = \frac{P(AB)}{P(A)} \quad (1)$$

By symmetry it may be shown that:

$$P(A/B) = \frac{P(AB)}{P(B)} \quad (2)$$

Solving for $P(AB)$:

$$P(AB) = P(A)P(B/A) = P(B)P(A/B) \quad (3)$$

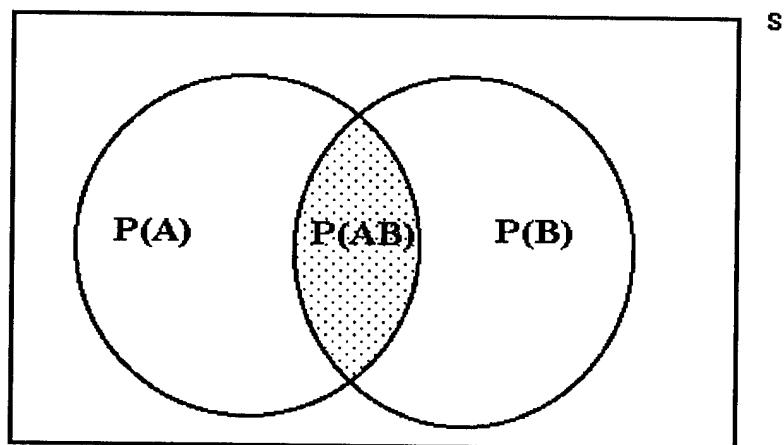

Figure 4 - 2: Venn Diagram

4.3 Risk Model

Utilizing the above concepts to develop a risk model, the tasks are broken into three levels.

Level 1: Develop a probability of damage and the extent to the ship as the it responds to an initiating event: **P(damage extent)**.

Level 2: Given that an extent of damage has occurred, what is the probability that oil will outflow to the environment: **P(outflow|damage extent)**.

Level 3: Given that oil is released to the environment, what is the probability of impact to the environment: **P(impact|outflow)**.

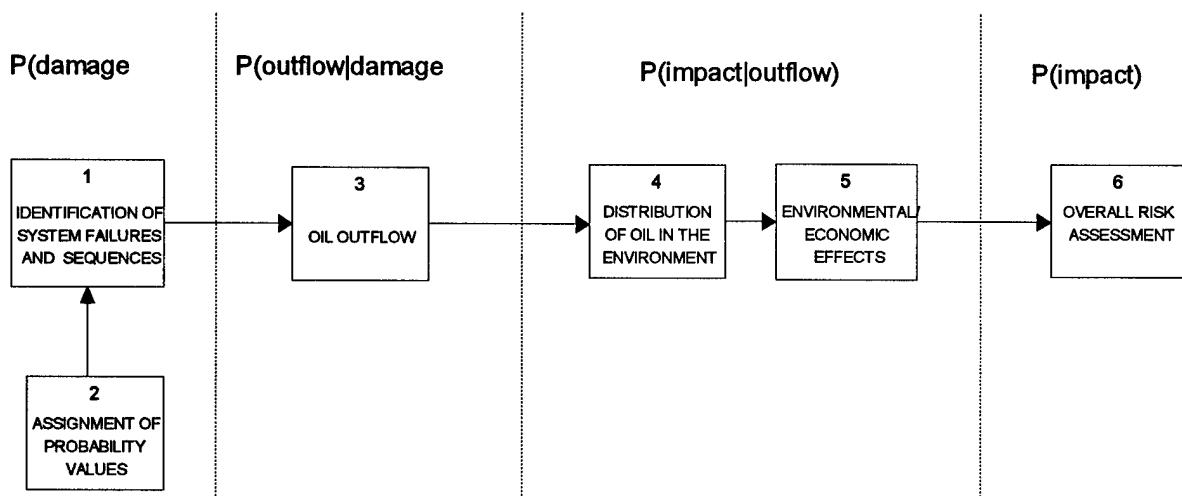

Figure 4 - 3: Risk Model

Ultimately, the probability of oil pollution producing adverse economic and environmental consequences can be evaluated:

$$P(\text{impact}) = P(\text{damage extent}) \times P(\text{outflow|damage extent}) \times P(\text{impact|outflow}) \quad (4)$$

4.4 Fault Trees

Complex systems that have multiple failure modes with physical and operational interactions lend themselves to fault tree analysis, especially if the role of humans in the operation needs to be modeled [39]. Fault tree analysis was developed for the aerospace industry for system safety analysis. It was later extensively used in PRA's for the nuclear power industry [19].

A fault tree is a graphical display to show how the basic component failures can lead to a pre-determined system failure state. In constructing a fault tree, one starts with a particular failure or undesired event and deductively works backwards to explore all the combinations of events that may lead to that particular failure. The fundamental building blocks of the fault tree are the AND gate and the OR gate (Figure 4-4).

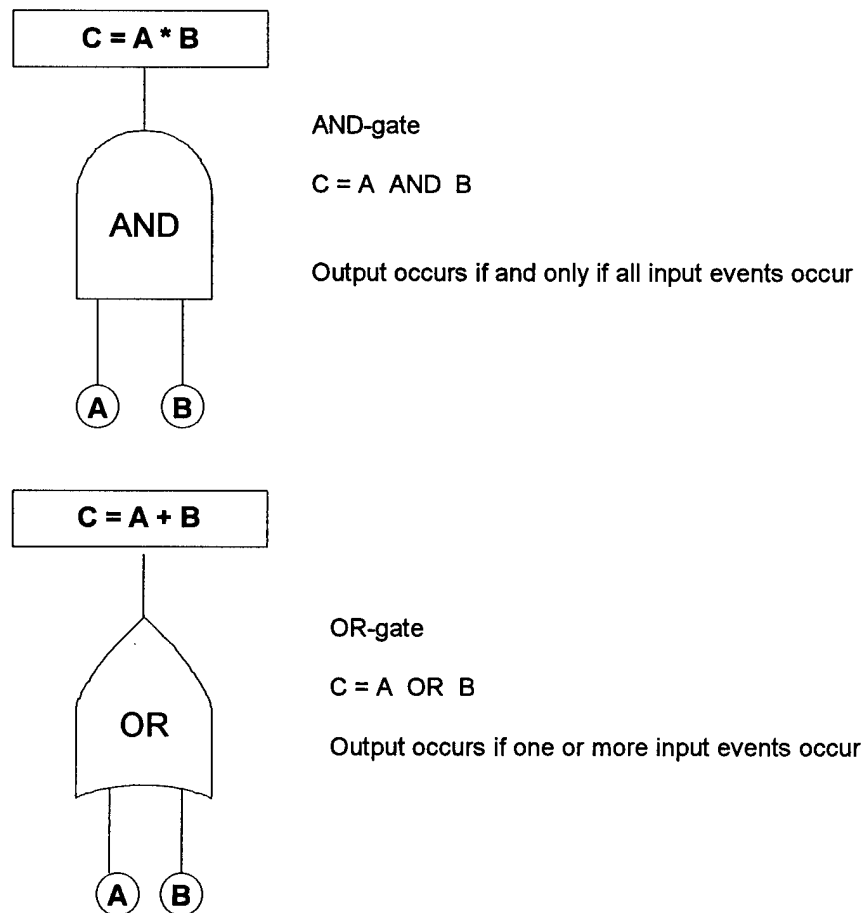

Figure 4 - 4: AND and OR Gates

The reasoning used to build a fault tree for a system requires an understanding of the system and its intended use. At each reduction stage of the fault tree, the general causes for the undesirable top event must be determined in as broad of terms as possible. By being as general as possible at each reduction stage, it is more likely that all possible combinations of events may be taken into account. "Elegant simplicity instead of unnecessary complexity is to be encouraged" [5].

Once the system is depicted in a logic diagram, the minimum cut sets can be determined. A minimum cut set is defined as a set of system components such that if all the components fail, system failure results, but if any one component has not failed, no system failure results [54]. When the minimum cut sets are identified, the appropriate probabilities can be assigned and the probability of the top event can be calculated.

4.5 Event Trees

Event trees represent the complete event space, consisting of the events that are possible in a system [54]. Event trees are usually developed in binary format where the events are assumed to either fail or succeed. A sequence of events are then analyzed to determine how failure might occur. Although deductive in principle, the construction of an event tree requires a good deal of inductive reasoning by the analyst [39].

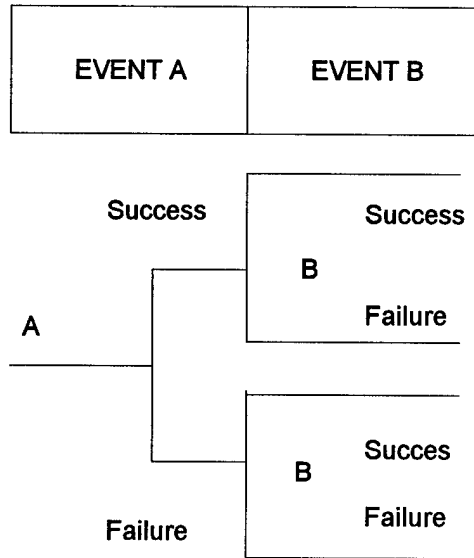

Figure 4 - 5: Event Tree

Event trees are constructed from initiating events, subsequent events either fail or succeed until all of the events in the event space occur. The logical representation of each event is obtained and then reduced through the use of Boolean algebra.

4.6 Summary

The risks involved the tanker industry need to be better understood. There needs to be a systematic approach to understand, identify, and minimize the risks. Once the risks are understood, and consideration is made of all the issues, the components of the system, and their synergism, the proper framework can be developed which addresses a wholesale solution rather than discrete problems.

The basic tasks required to undertake a systematic assessment have been outlined. The proposed risk model outlines three levels of assessment that will lead to the probability of oil pollution producing an impact upon the environment. The approach has matured in the nuclear industry. Many of the issues undertaken in the nuclear industry are germane to ships.

Chapter 5 Human Failure and Accidents

5.1 The Prevalent Factor

Human error is a common feature of everyday life. Errors occur for many different reasons, and usually involve a complex interaction of many different factors. Human errors have been shown to underlie the failures of many engineered systems. Human error can either be an immediate accident initiator, or it can play a dominant role in the progress of undesired events [39]. In almost all cases, the initiating event of a high consequence accident is traced to a catastrophic compounding of human errors [5].

The pervasiveness of human error in the maritime industry has been known for a number of years. For example, in 1972, the chairman of the American Hull Insurance Syndicate revealed that 85 percent of the Syndicate's claims payments were for human-error casualties [45]. In 1976, the National Research Council (NRC) attributed 80 percent of vessel collisions, rammings and groundings to human error [45]. As ships have become larger, the tolerance for human error has decreased, while the consequences have increased immensely. Still, as a whole, little has been done to effectively address the issue of human error. More recently, in 1993, the UK P&I Club reported that 62 percent of the major claims associated with commercial shipping were a result of human error [33]. The large number of incidents attributable to human error is not just constrained to the commercial arena. A report by the U.S. Naval Safety Center found that human error caused 70 to 85 percent of mishaps involving U.S. naval vessels from 1989 to 1993 [36].

It would seem that the high percentage of accidents attributed to human error have become accepted as a norm of the maritime industry. Jerry Aspland, retired president of Arco Marine states [2]:

Twenty-five years ago, I heard the quote, "85 percent of all maritime accidents are caused by human error." One month ago, I heard the quote "85 percent of all maritime accidents are caused by human error."

Is this coincidence or the result of the marine community's failure to address a most complex system: human behavior?

Arco Marines's study of human behavior determined that alertness has the primary impact on human error. This is exactly what the NRC [45] determined in 1976. The implication is that the alertness issue has been known for nearly 20 years, yet nothing has been done to properly correct it.

While studies of human factors in maritime safety have addressed a myriad of subjects, few of the studies have linked their conclusions to the ship accident experience [18]. For example, the conclusions of the NRC's 1976 study were broad and multi-faceted [18]. Table 5-1 presents the panel's conclusions.

Table 5 - 1: Factors Contributing to Marine Casualties

Inattention	Poor eyesight	Inadequate lights and markers
The ambiguous Master-Pilot relationship	Excessive fatigue	Misuse of radar
Inefficient bridge design	Excessive alcohol use	Uncertain use of sound signals
Poor operation procedures	Excessive personnel turnover	Inadequacies of the rules of the road
Poor physical fitness	High calculated risk acceptance	

The study offered some insight to the causes of human error, but failed to recommend effective actions that the industry could implement. Gardener comments on such studies [18]:

Recommendations that result from such studies cover everything from requiring expensive new equipment to changes in nearly every aspect of law, regulation, staffing, training, design, and operation of ships. Generally, none of these recommendations is suitably evaluated for range of applicability, expected benefit, social and economic cost, and locus or form of implementation. Many of the recommended actions have much less value upon close study than at first glance.

5.2 Human Failure

What has typically been called human error, really encompasses more than just the act of an individual. Human error, as it is typically used in attributing accidents, should be broken down into two sets:

1. Human Failure.
2. Individual Errors.

The over-use of the term “human error” seems to lead to an apathetic perspective. Dougherty [15] suggests that the term “error” is unwarranted in many high-risk accidents and it can lead to the mis-allocation of resources and an inability to avoid future accidents. Even though some failures are attributable to people, and it is common to call all such failures human errors, it is the design of the system itself that is prone to error. In fact, individual errors may not even comprise half of all the human failures [15]. Figure 5-1, adapted from Dougherty and Fragola [15], presents the context of human failures and errors.

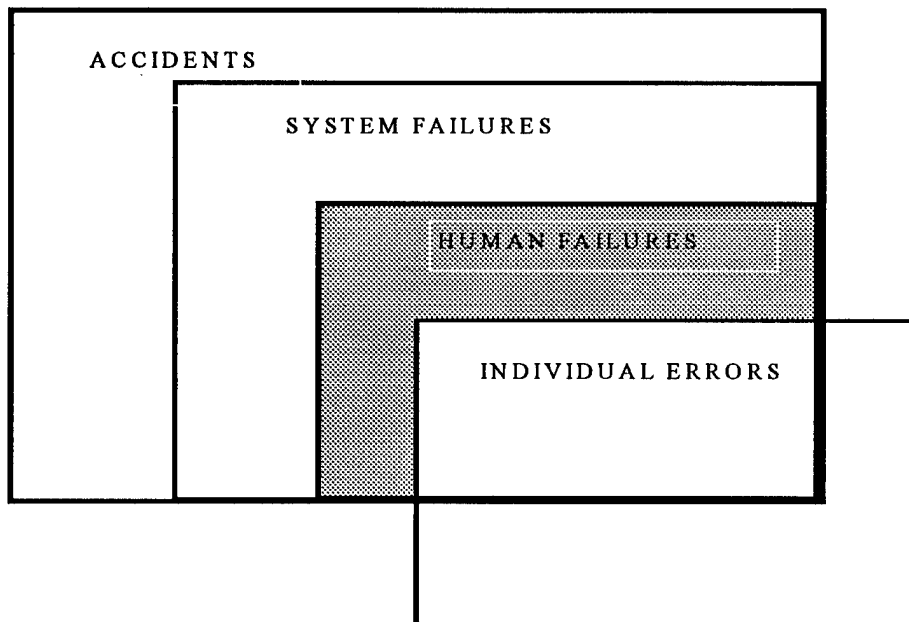

Figure 5 - 1: Context of Human Failures and Individual Errors

An accident is an event or occurrence that has negative result, effects, or consequences. Accidents can be induced by factors internal and external to the system. External factors would include natural disasters or other contributions outside of the system. A system failure is an event or occurrence that has negative consequences upon the system's functioning [15]. Human failure is a system failure that can be proximally attributed to the actions or inaction of one or more people [15]. Individual errors are also system failures, but their root cause can be attributed to a single person. There can be individual errors that have no significant consequences and are not a part of an accident's causal chain [15].

Perrow states that, "In an error-inducing system, the tendency to attribute blame to operator error is particularly prominent" [53]. Perrow is suspicious of the 80 percent human error attribution in marine systems. He suggests the following [53]:

1. 40 percent unforced operator error: component failures where the operator is the component that failed.
2. 5 to 10 percent system accidents: a system accident is an integral characteristic of the system, the interactive complexity and tight coupling of the maritime system inevitably will produce an accident.
3. 30 to 35 percent forced operator error: errors resulting from a complex and tightly coupled system which requires long hours, has misplaced priorities, and skewed incentives.

5.3 Failure Classification

Human failure should be categorized to show the impact of all the factors contributing to, and the motivation of, those individual actions which result in an accident.

Human failures can manifest themselves as follows [26]:

1. Active: failures resulting from almost instantly observable effects.
2. Latent: failures not immediately noticeable.

Active failures, usually associated with direct and responsive operations, are recognized immediately. Latent failures result in adverse consequences that may lay dormant within the system for a long time, only becoming evident when they combine with other factors [57].

There are numerous schemes to characterize and classify human failures and its causality. Human failure may occur in any phase of the design, construction and operation of a complex system [39]. Unsatisfactory performance can be the result of improper design and construction of the system. Of the three phases, design, construction, and operations, the majority of compromises occur during the operating phase and can be attributed to errors developed by operating personnel [3]. Constraining the study to the operations phase, a useful breakdown of high consequence accidents is shown in Figure 5-2.

Accidents are distinguished between environmental and human factors. Accidents due to environmental factors are those unavoidable environmental events that exceed the reasonable demands of the structure during its lifetime [3]. Accidents resulting from human error can be differentiated into those caused by design, construction, and operations. Focusing on operations, the elements of human failure are influenced by the synergistic effects of:

1. Individuals.
2. Hardware.
3. Organizations.
4. Environment.
5. Procedures.

The amount of interdependence reflects the amount of coupling within the system. In a tightly coupled system, each area can not be addressed in isolation.

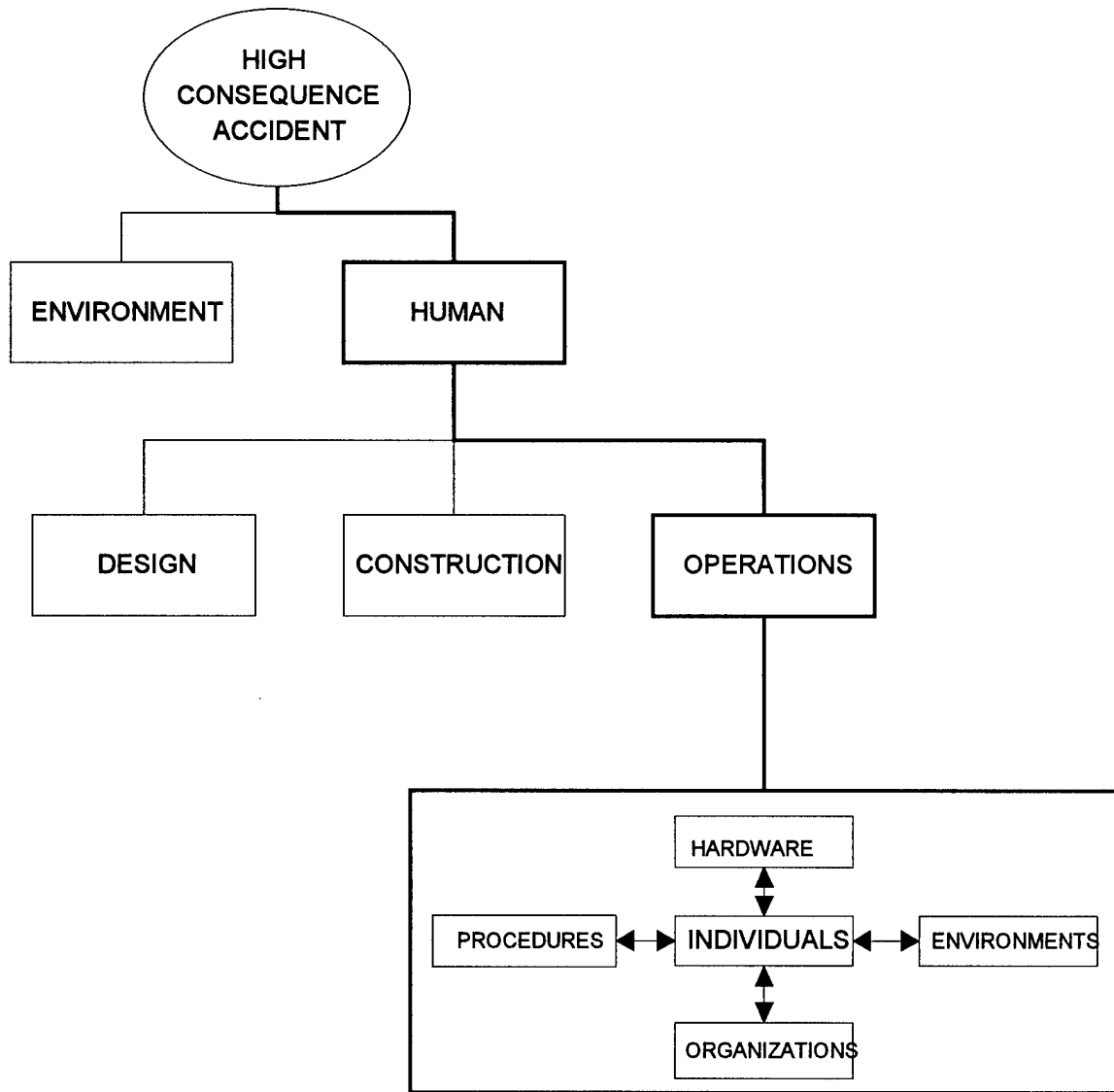

Figure 5 - 2: Classification of Human Failure

While the importance of human failure has been known, little has been done to effectively address it. Unfortunately, there are several technical problems in trying to assess the reliability of humans in a risk setting, as human risk assessment is a relatively new discipline [15]. Rather than properly address human failure, the industry has focused on technological and structural fixes to address accident prevention.

There is a tendency towards the ideology that only technology is allowed to promise progress, that replacing technological products with manual operators is a step backwards

[20]. But technology can increase human risk and the susceptibility for human failure by increasing the complexity and creating a more tightly coupled system. Even though major technological advances have occurred and been implemented, the attribution of human failure has remained relatively constant over the past 20 years. Many accidents are induced by failures of technological systems, which seem to arise from the complexity of the systems themselves [53].

5.4 Individual Errors

There have been a number of studies undertaken to classify individual errors and error factors. In 1976, the Panel on Human Error in Merchant Marine Safety defined 13 types of individual errors into which all potentially harmful individual behavior was grouped (Table 5-2) [45].

Table 5 - 2: Categories of Individual Errors

Panic or Shock	Inattention	Negative Transfer of Training
Sickness	Incompetence	Negligence
Drunkenness or Drug Influence	Anxiety	Ignorance
Confusion	Fatigue or Drowsiness	Calculated Risk
Fear		

Based on a study of unanticipated compromises of acceptable quality involving marine structures resulted in a list of individual error factors summarized in Table 5-3 [5]. Both studies reflect approximately the same factors which influence individual error.

Table 5 - 3: Individual Error Factors

Fatigue	Wishful Thinking	Bad Judgment
Negligence	Mischief	Carelessness
Ignorance/Panic	Laziness/Violations	Physical Limitations
Greed	Drugs	Boredom
Folly/Ego	Inadequate Communication	Inadequate Training

Sometimes causality is difficult to determine. For example, a great number of collisions-at-sea occur between ships that are not on a collision course until one or both ships change course after becoming aware of each other in such a way as to effect a collision [53]. Part of the explanation is the way human's process information. People tend to construct an expected world because the real world is too complex, then the available information is processed to fit the expected [53].

The act of navigating and piloting a ship is information processing. The construction of, and reaction to, an expected situation challenges the easy explanations for human error such as stupidity, inattention, risk taking, and inexperience.

The construction of an expected situation occurs from the way people process information. Humans inherently introduce biases in the way they seek information, estimate probabilities, and attach values to outcomes. It is because of these biases that decisions based upon even the best of information can be flawed. The following is a short list of some of these biases [59]:

1. People give an undue amount of weight to early evidence or information. Subsequent information is considered less important.
2. Humans are generally conservative and do not extract as much information from sources as they optimally should.
3. The subjective odds in favor of one alternative or the other are not assessed to be as extreme or given as much confidence as optimally they should.
4. As more information is gathered, people become more confident in their decisions, but not necessarily more accurate.
5. Humans have a tendency to seek far more information than they can absorb adequately.
6. People often treat all information as if it were equally reliable, even though it is not.
7. Humans appear to have a limited ability to entertain a maximum of more than a few hypotheses at a time.
8. People tend to focus on only a few critical attributes at a time and consider only about two to four possible choices that are ranked highest on those few critical attributes.
9. People tend to seek information that confirms the chosen course of action and to avoid information or tests whose outcome could disconfirm the choice.

10. A potential loss is viewed as having greater consequence and therefore exerts a greater influence over decision-making behavior than does a gain of the same amount.

11. People believe that mildly positive outcomes are more likely than mildly negative outcomes, but that highly positive outcomes are less likely than mildly positive outcomes.

12. People tend to believe that highly negative outcomes are less likely than mildly negative outcomes.

Computers and other technology can aid in the decision process by aggregating the available information and processing for the best outcome. Fundamentally, an understanding of human information processing is essential to further develop ship systems.

5.6 Hardware

Systems of inadequate design exacerbate human failure. The hardware portion of a system is a collection of equipment that has specific, intended functions, and interacts among its pieces and with the people and software that operate the system [15]. While technology is increasing equipment reliability, some believe that it is reducing the human reliability of its operation [26]. Engineers are often wont to incorporate new technology, but these new technologies tend to compound latent system flaws [5]. These latent flaws can be manifested in a complex design, close coupling (failure of one component leads to failure of other components), difficult maintenance, and severe performance demands.

Technology must also balance its ability to liberate human functions with the inevitability of human boredom when operators shift from doing to monitoring. Technological developments incorporating automated systems change the role of the operator from an active to a passive participant. The longer the individual is removed as an active participant, the less likely the person will have a clear understanding of the inner workings of the system should a crisis occur [43].

5.5 Procedures

A taxonomic system relating skill, knowledge and rule-based actions to an operational task is shown in Figure 5-2 [15].

The taxonomy shows the role of procedures in terms of a rule-based action and diagnosis based on the complexity of task to be completed. If diagnosis or decision making is needed but no rules are available to assist the activity, then action must be based on a deep fundamental knowledge [15]. Skills include pattern recognition and actions that are manual, well trained, well known, and practiced frequently [15]. Where either skill or knowledge is insufficient or inappropriate, rule based-behavior is essential.

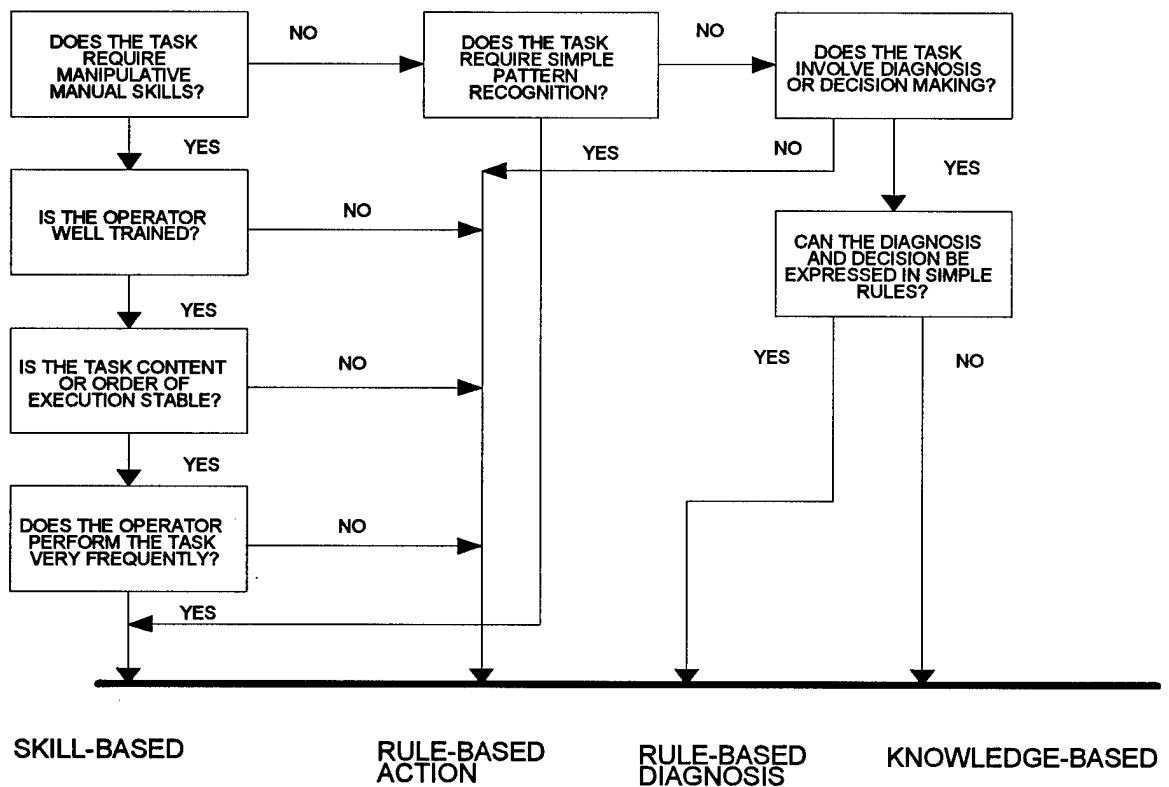

Figure 5 - 3: Embrey's Taxonomic System

Since absolute skill and knowledge can not be achieved for the various levels of operation of an oil tanker, there must be minimum levels of expertise with appropriate procedures. Voyage planning, pre-underway check-off lists and explicit communication procedures are all examples of necessary rules that must come from an overall procedural framework that needs to be developed, evaluated, implemented and enforced.

5.7 Organizations

The influence of the organizations on the reliability of marine systems is the most pervasive of the human failure related accidents [5].

Organizations have an impact on individual response as a result of its structure and culture. Both structure and culture are functions of each other. As the NRC states [48]:

The traditional command and leadership relationship has been considered necessary to maintain order and discipline, especially when faced with operating conditions that threaten the vessel, officers, and crew. But the hierarchical structure results in unidirectional, top-down communications. Marine language and practices that derive from this traditional structuring leave little room for the development of a culture that encourages bottom-up communication or the provision of rewards when it happens. . . This may be an important deficiency in the marine navigation and piloting system. . . Communication of problems detected by subordinates and solutions they may propose can be stifled by the rigidity of the traditional bridge organization and culture unless the operating company, through the master, has fostered a more receptive bridge team communications environment.

The goals set by an organization can be the impetus for otherwise rational people to make irrational decisions. Pressures to reduce costs and maintain schedules may suppress the prudence of safe operations.

Faulty decisions and subsequent erroneous navigation that lead to accidents can be related to the communication flow-path among the crew. But it is the organization which establishes the structure of the communication flow-path. The safety of passage requires that the crew function as a team, especially in a restricted maneuvering setting. Sharing information and support among bridge team members is required to safely navigate the range of hazards and conditions encountered [48]. Since access to information is typically divided among the team members, a loss in the smooth functioning of the team results in a break in the flow of information.

Other aspects of the organization are the individual differences among crew members. These differences are amplified when multi-national crews are employed. Language barriers, cultural and economic background all influence the cohesiveness of the team.

Fundamentally, the faults described above can be broken into two classes of problems facing organizations [5]:

1. Information: who knows what and when.
2. Incentive: how are individuals rewarded, what decision criteria do they use, how do these criteria fit the overall objectives of the organization?

5.8 The Environment

External and internal environments contribute to human error.

1. External factors: darkness, extreme temperature, storms and other natural phenomena.
2. Internal factors: lighting, temperature, noise levels, and vibrations.

Environmental effects can create psychological and physiological human responses that can exacerbate the potential for human error.

5.9 Summary

Human failures encompass more than individual errors. The tendency to classify all human failures as individual errors has led to the notion that these failures are a part of human nature. As long as humans operate ships, there will be individual errors. Studies of the role of human failures in engineered structures have shown that they are inevitable [3], but many human failures can be prevented through the appropriate management and technology.

Specific programs which can be implemented or enhanced to reduce the probability and/or effects of human failures are:

1. Qualification and training.
Licensing.
2. Procedures.

Normal Operating.
Emergency Operating.
Maintenance.
Emergency Preparedness.

3. Technical Specifications.
4. Human-machine Interface.
Bridge.
Propulsion Control Rooms.
5. Organization and Management.

Given the continued rate of accidents attributable to human errors, engineers, managers, and regulators need to begin formally addressing human factors in design, construction, and operations of marine systems [3].

The classification for human failure has been presented in general terms in order to present the overwhelming nature of the problem. Once the identification of system failure and sequences has occurred, (step 1 of the basic PRA tasks - Figure 4-1), many of the fundamental faults will be due to human failures. It will be necessary to take a more detailed analysis of causality to determine the nature of the failures, and the significant factors contributing to the failures in order to assign probability values (step 2 of Figure 4-1).

Chapter 6 Planning and Piloting

6.1 Navigation Control Model

The causality of human failure to order the proper course requires an evaluation of how errors are created in the ship piloting and navigating process. It must be recognized that maneuvering a ship on the proper course involves the constant comparison of actual position to expected position.

The piloting process can be viewed as a feedback control system. A feedback control system is a control system that tends to maintain a prescribed relationship of one system variable to another by comparing functions of these variables and using the difference as a means of control [14].

To illustrate the concept of a feedback control system, consider the human being as the controller driving an automobile. The driver constantly compares the position of the automobile on the road with his idea of a safe position. When the controlled/actual position exceeds an acceptable tolerance from the reference/safe position, the driver observes the error and either turns the wheel, operates the break, or operates the accelerator to minimize the error.

With the mariner there must be a conscious effort to fix the ship's position and adjust the course and speed as necessary to either maneuver the ship back to, or keep the ship on, its intended track. The time for the ship to react to a change in speed or course is not immediate. Additionally, the environmental conditions significantly affect the ship's response. The competent mariner must continually seek answers to the following questions: "Where is the ship now?" and, "Where is the ship going to be in the next minute; hour; or day" [23]?

A simple block diagram of a navigation control system is shown in Figure 6-1.⁸ The desired course and speed are determined by comparing the planned track and any changes forced by external events, to the actual course. The desired course has a feedback structure to allow for any changes imposed by external events (weather, personnel, mechanical failure, etc.), changes are then considered by imposing the new boundary conditions and re-evaluating for the intended track.

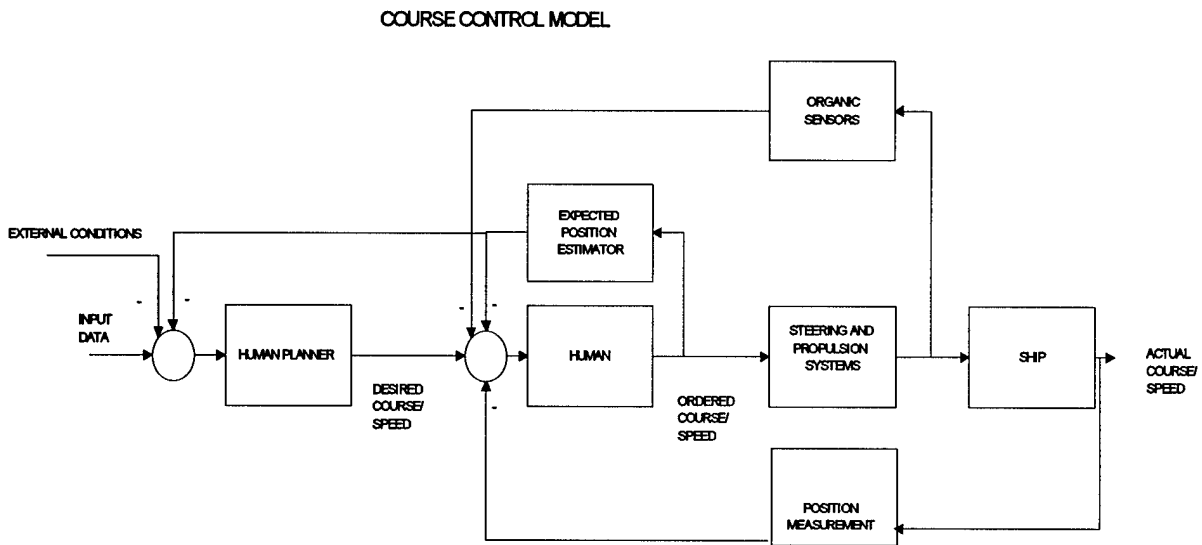

Figure 6 - 1: Navigation Control Model

Once the intended track (desired course/speed) is deduced, the ordered course/speed is then determined by considering the error generated through the process of comparing the measured course/speed to the desired course/speed. An expected position is determined from the ship's course, speed, and environmental effects through the process of dead reckoning. The conning officer (the officer standing watch responsible for the safe piloting and navigation of the vessel) must recognize any errors generated and act to minimize those errors.

In the open ocean, with little or no traffic, the navigation system is tolerant of errors. It can exist in a failure state without any serious ramifications. But as ships approach narrow, restricted channels and high density traffic, the error tolerance decreases significantly.

⁸ Figure 6-1 presumes an elementary knowledge of control system theory. Dorf [14] provides an excellent introduction to control system theory.

6.2 Navigation and Piloting

The navigation of a ship is divided into four primary classifications [34]:

1. **Piloting:** determining the position and movements of a ship by reference to land and sea marks, by depth, or by radar.
2. **Dead Reckoning:** the projection of a present position, or anticipated future position, from a previous known positions using the best available information.
3. **Celestial Navigation:** the determination of position by observing the celestial bodies.
4. **Radio Navigation:** the determination of position using the radio frequency spectrum, e.g. radar, satellites.

Piloting requires the greatest experience of any form of navigation. Mistakes of navigation on the open ocean can generally be discovered and corrected before an casualty is incurred. In pilot waters, there is little or no opportunity to correct errors [34].

The fundamental process of determining the ship's actual position is through dead reckoning. The initial element of the ship's dead reckoning (DR) plot is the fix. A fix is determined by the intersection of a least two simultaneous lines of position (LOPs). The ship lies on the LOP and the fix localizes the position by intersecting two or more LOPs.

The mechanics of piloting can be intensive. Personnel constraints on commercial vessels leave the act of navigation and piloting to one or two officers. Since speed and efficiency are of prime importance, it is not uncommon for the officer on watch to rely primarily on radar bearings and ranges, and on visual bearings only for verification or where the need for accuracy dictates [34].

Before entering restricted waters, a local certified pilot embarks to lend expertise in negotiating the entry. When the pilot boards, he must be immediately acquainted with the characteristics of the ship and a plan should be offered for his approval [6]. The basic passage plan for pilotage waters is agreed by the pilot and adjusted to his advice before being

undertaken. Having a pilot on board does not relieve the Master from the responsibility of ensuring a safe passage.

6.3 Voyage Planning

Modern methods of determining a ship's position include various inertial, radio and satellite navigation systems. Supplemental to these electronic methods are the manual methods for fixing a ship's position by intersecting lines of position. It must be remembered that once a fix has been obtained and plotted, it does not represent the location now or in the future, rather it only reflects where the ship was at the time of taking the lines of position. The ships projected position must be plotted through the technique of dead reckoning. These elements of navigating and piloting a ship are integrated through the process of voyage planning.

The key to successful planning of any voyage is advanced preparation. Planning is a fundamental principle of safe navigation [34]. A properly planned voyage consists of more than just a scheduling of the courses and speeds to get from the origin to the destination in a specified amount of time. A voyage plan must consider weather, personnel, other shipping, machinery, and any possible contingencies that may be encountered. In a mathematical sense, voyage planning is the determination of the following integral, where the necessary considerations impose boundary conditions upon the process:

$$\int_{t(\text{origin})}^{t(\text{destination})} v(t) dt = X_{\text{final}} - X_{\text{initial}} \quad (5)$$

Every passage, every departure from and entry into port must be planned in advance, based on all the information available. In voyage planning, the planner must evaluate, from the available information, the desired route and any alternative routes to account for contin-

gencies. The essential considerations involved with planning any voyage include the following:

1. **Schedule:** management of a tanker requires adherence to a schedule to perform loading and unloading operations thereby imposing time constraints for arrival and departure dates.
2. **Navigational Information:** Navigational information is that information which is necessary to detail the possible safe routes, and outline any hazards to avoid in order to transit from the origin to the destination. It includes the expected open ocean and tidal currents, prevailing weather, and navigational aids.
3. **Equipment/Personnel:** Equipment and personnel considerations impose time constraints on the process. Equipment status, maintenance schedules, and availability of properly qualified personnel can compel departure and arrival dates which otherwise might not be considered.
4. **Procedures:** The procedural aspects of voyage planning includes the process of determining the aforementioned considerations.

Recall that the planning process is the evaluation of equation (5). To ensure that the many facets of a voyage are not overlooked, the procedures for planning a voyage should include a check-list to lay out all of the anticipated requirements, such as:

1. The required charts and publications.
2. Expected currents and tides.
3. Navigational aids.
4. Traffic separation and routing schemes.
5. Navigational warnings.
6. Navigational equipment status.
7. Ship's maneuvering data.

(There are many more aspects to consider, reference [6] provides a more complete checklist.)

Every passage is accompanied with the potential of having to abandon the plan owing to changed conditions or circumstances. These changed conditions may arise with little or now warning, allowing no time for a full reappraisal. Experience has shown that certain events are more likely than others, hence alternative plans can be appraised for likely deviations, such as [6]:

1. Delay due to reduced visibility.
2. Pilot, tugs, berths not available.
3. Changed tidal conditions.
4. Breakdown of ship or equipment.
5. Diversion to a new destination.
6. The need to seek refuge owing to heavy weather.

Prior to getting under way, the ship's preplanned "track" should be laid down on the appropriate charts. The ship's track is described by the appropriate course and speed vectors which outline the intended path that the ship would follow over ground. This track then represents the desired course and speed of the ship.

In conjunction with plotting the track, safe limits of navigation should be clearly marked. Safe limits of navigation should be referenced to a precomputed visual bearing, either to a prominent landmark, or navigational aid. Additionally, "turn bearings" should be annotated and referenced in the same manner in order to turn the ship at the correct time.

Knowledge of the ship's maneuvering characteristics is vital in pilotage waters. Specifically, consideration must be taken of:

1. Advance: the distance gained in the original direction until the ship steadies on her new course.
2. Transfer: the distance gained at right angles to the original course, measured from the line representing the original direction of travel to the point of completion of the turn.
3. Head reach: the distance that a ship will travel from the point where action is taken to stop it to the point where it is dead in the water.

The distances required to turn or stop a large ship can thousands of yards. The response in shallow water becomes degraded.

In the evaluation process there are spatial and temporal constraints that must be considered. The spatial constraints dictate the course of the track in order to avoid any hazards to navigation. Temporal constraints, which are imposed by schedules, affect the speed of the track. Consideration must be made of weather, shipping channel speed limits, and the maneuverability of the vessel.

6.4 Summary

Planning, piloting, and navigating are rudimentary processes for the operation of any ship. To properly assess the risks of tanker operations, there must be a fundamental understanding of the planning, piloting and navigating processes. The concepts will be further exploited to develop the fault tree used to model tanker risks.

Chapter 7 Developing the Fault Tree

7.1 Classification of Spills

The first step in assessing the probability of impact (Figure 4-3), is to identify system failures and sequences. Fault trees provide a systematic methodology to identify system failures. The first step in developing the fault tree is to determine the top event. The top event will be accidental oil outflow. However, there is no typical tanker vessel accident scenario that leads to pollution [47], so it is necessary to categorize the major classes of accidents which result in pollution. Tanker incidents are typically categorized as follows:

1. Collision
2. Grounding.
3. Fire/explosion.
4. Structure/hull failure.

Figure 7-1 [47] graphically displays the causes of major oil spills from tankers for 1976 to 1989. For each class of accidents, initiating events must be developed which produce the top event.

With the major classes of accidents classified as in Figure 7-1, the next step is to structure each class of accident in a fault tree. Figure 7-2 shows the first level of a fault tree for a tanker accident that results in the top event of accidental oil outflow.

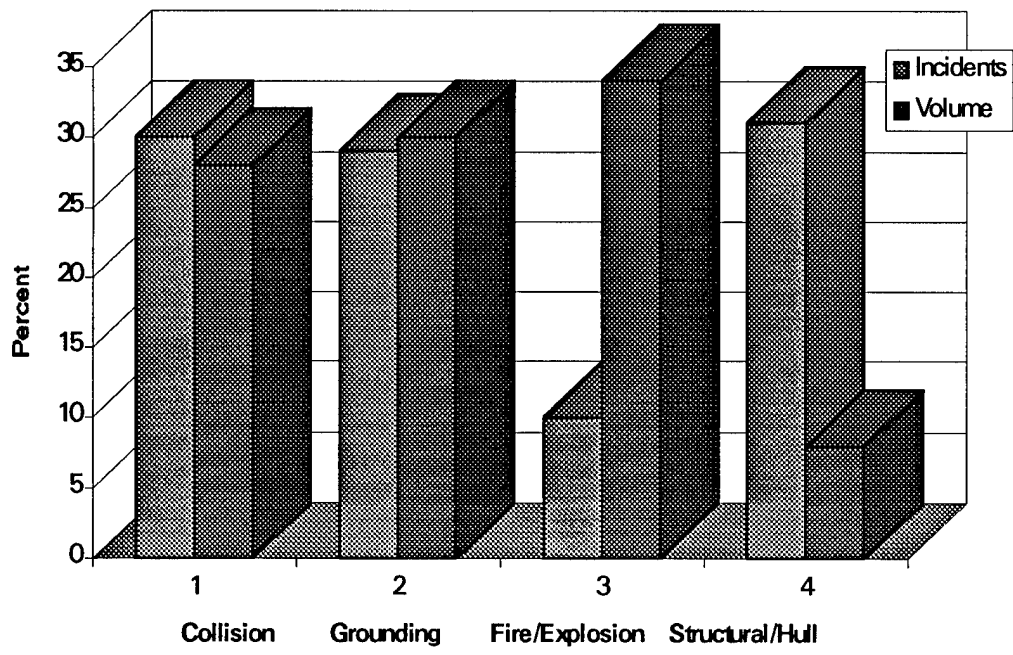

Figure 7 - 1: Major Oil Spills from Tankers and Causes - 1976 to 1989.

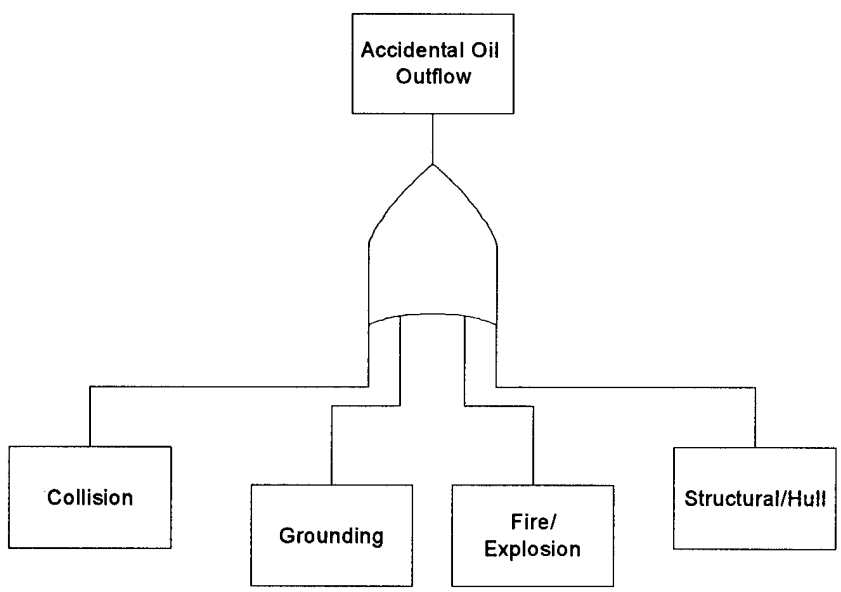

Figure 7 - 2: Basic Accidental Oil Outflow Fault Tree

7.2 Groundings as a First Analysis

Groundings and collisions together represent the largest contribution, by volume and number of incidents, to oil pollution. When analyzing a collision, an *In Extremis* situation necessarily precedes. *In Extremis* situations require both vessels to maneuver to avoid collision. The fundamental cause of a collision, regardless of the vessel, is the failure to maneuver to avoid the collision. Many of the same avoidance factors that are functions of collisions are relevant to groundings. The difference between the collision and grounding analysis is the number of ships involved. Where the collision necessarily involves the dynamics of two ships, the grounding involves one. The NRC found that for tankers over 10,000 dwt, grounding events dominate in terms of both numbers of accidents and volume spilled [47]. Hence, the first analysis will be for the grounding accident.

As the fundamental cause of a collision is allowing another's vessel to get too close, an analogous statement may be said of a grounding: the sole cause is allowing one's vessel to venture into waters where the draft exceeds the depth [7].

Cahill [7] describes a series of well-documented groundings. The fundamental reason for allowing the vessel's draft to exceed the depth of water for those groundings, was an improper human response to an indication. In essence, human failures prevail as the predominate factors in grounding accidents.

7.3 Developing the Grounding Fault Tree

To further develop the fault tree for groundings, recall that a grounding is caused by the ship entering an area where the draft exceeds the depth. It becomes necessary to determine why the ship has encountered that situation. Fundamentally, the ship can either follow a safe track or an unsafe track. An unsafe track necessarily intersects a hazard. (The hazard is that encounter where the draft exceeds the depth.)

A vessel can survive in a failure state if it does not intersect a hazard. Interest lies only in the case where the infinite possible combinations of integrating the velocity vector result in the final position of the ship the same as the hazard:

$$\int_{t(\text{origin})}^{t(\text{destination})} v(t) dt = X_{\text{hazard}} - X_{\text{initial}} \quad (6)$$

Given that the grounding failure state is the state of interest, the ship is following an unsafe track. Because the ship is proceeding down an unsafe track, there are two concerns to investigate:

1. The ship is able to follow a safe track
2. The ship is unable to follow a safe track.

If the ship is able to follow a safe track, then a determination must be made of why it is proceeding down an unsafe track. Figure 7-3 depicts these concepts in the fault tree.

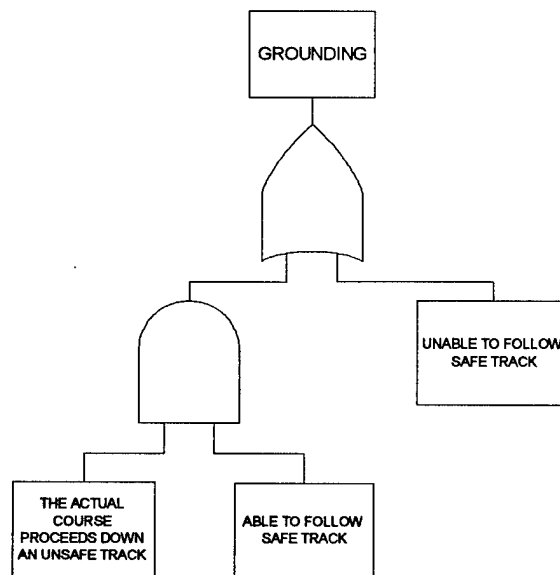

Figure 7 - 3: Basic Grounding Fault Tree

By deductively reducing each successive step in the top-down approach, the fundamental causes of groundings can be understood and evaluated. Continuing with these seemingly rudimentary steps in order to determine successive causes will create the complete fault tree shown in Figure 7-4. The process of developing the fault tree is subsequently described.

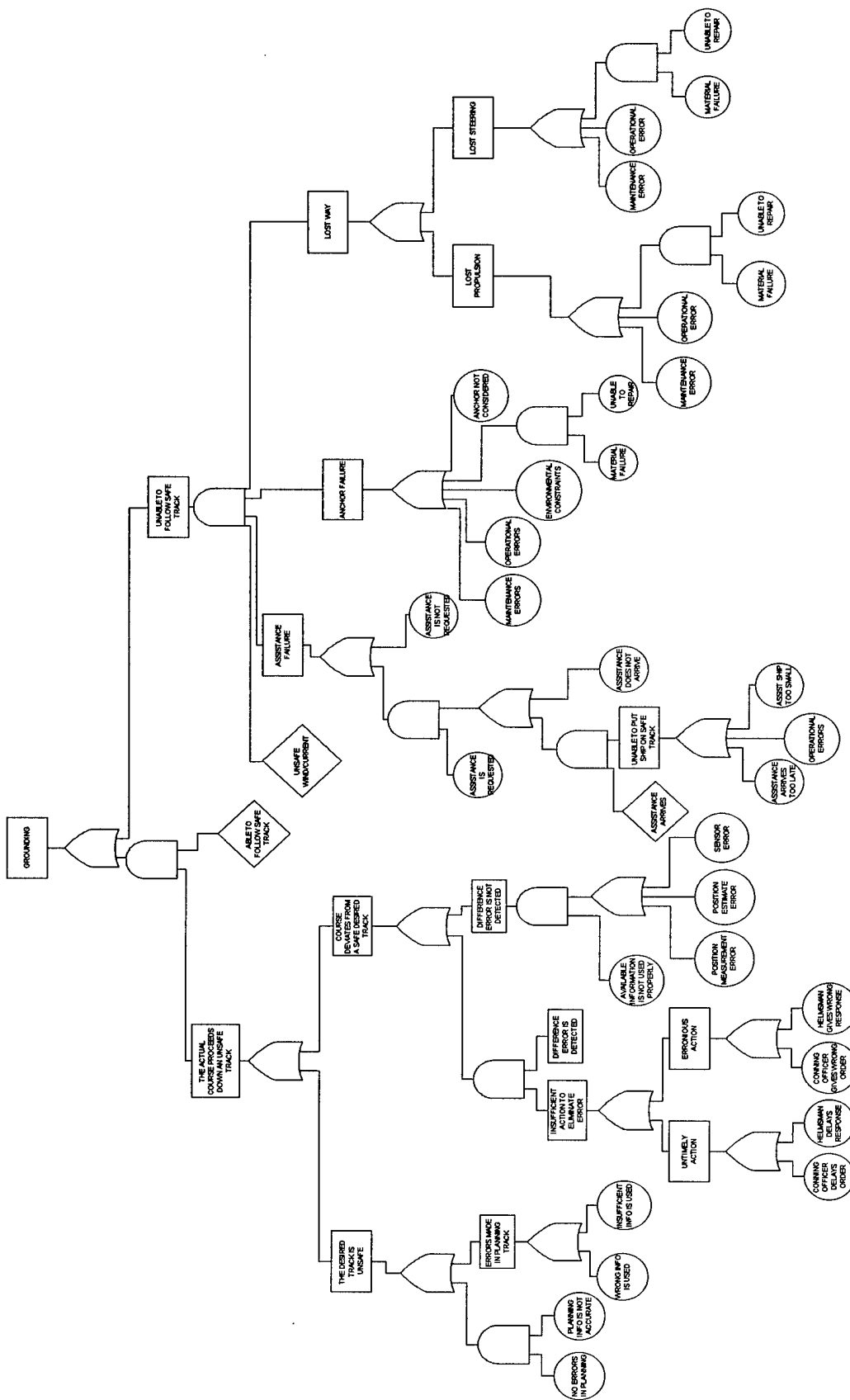

Figure 7 - 4: Grounding Fault Tree

7.4 The Actual Course Follows an Unsafe Track

The ship's actual course is following an unsafe track, yet there is nothing physically preventing the ship from following a safe track. Thus, two options can be deduced:

1. The desired track is unsafe.
2. The course has deviated from a desired safe track.

Given that the ship is capable of following a safe track, then, when the desired track intersects a hazard, causality is constrained to the planning process. However, when the ship's course deviates from a desired safe track to an unsafe track, causality is constrained to the piloting process.

7.4.1 The Desired Track is an Unsafe Track

It is necessary to determine where in the planning process that the desired track becomes coincident with an unsafe track leading to a grounding. The coincidence of a desired track and a grounding track can occur under two different scenarios:

1. Properly planned track: the process of planning has been completed satisfactorily.
2. Improperly planned track: errors have occurred in the planning process

Planning includes both the initial voyage planning, and the dynamic planning which is done as a result of external conditions imposing new constraints.

The importance of proper planning can be illustrated through the use of the navigation control model. Clearly, if the ship navigation control system were completely accurate, then groundings would not occur due to deviations of the actual course from the desired track. But even accurate systems will yield an undesirable response if the input is incorrect. As the colloquialism goes "garbage in - garbage out." For example, a ship proceeding without the correct chart reflects an improper input to the control system. Regardless of how accurate the fix, if the intended track intersects an unknown hazard to navigation, the accuracy of the

control system is irrelevant and the reliability of the system becomes limited by the reliability of the input.

Dynamic planning incorporates the same planning process, but it is done because some unanticipated event (weather, mechanical failure, another ship crossing the bow, etc.) has imposed new constraints upon the voyage. Dynamic planning is inherently a part of navigating and piloting a ship. It often requires a rapid decision, and it is typically a quality of a skillful conning officer.

When the course is properly planned with all available information but still intersects a hazard, the fault lies in the information itself (e.g. incorrect charts). The planner has utilized the most current information and evaluated the intended tracks properly. But because the most current information does not reflect the most current conditions, the intended track intersects a grounding hazard.

Groundings can and do occur due to inaccurate charts. Nautical charts are prepared from the latest available hydrographic surveys. Only a small portion of U.S. waters have been surveyed using the most advanced techniques, and 60 percent of the soundings shown on nautical charts are based on lead-line surveys conducted over 45 years ago [48].

For an improperly planned course, the voyage planning process has not been completed to success:

1. The wrong information is used: the correct information is available but is not used resulting in the wrong constraints placed upon the planning evaluation.
2. Insufficient information is used: the planning process is based upon incomplete knowledge of the voyage.

7.4.2 Actual Course Deviates from a Safe Desired Track

The ship can be on the wrong course because it has deviated from the desired track. Recall from the navigation control model, in Figure 6-1, that deviations, which occur as the actual course diverges from the desired track, create error signals which the conning officer must recognize. The inaccuracy of the system is reflected when there is either a failure to recognize that the ship's actual position differs from its estimated position, or a difference in

actual versus desired position results in insufficient action to eliminate the difference. After the difference is recognized, there must be an overt action to adjust the ordered course to keep the error as close to zero as possible.

Before proceeding any further it is necessary to review how a difference error is recognized. Most ships require a proactive interface between the sensors and the conning officer. The conning officer must take the initiative in the process. The proactive process of piloting a ship is dead-reckoning. Errors are detected by taking lines of position to fix the ship and compare the fix to the track. There will always be an error signal when the actual course deviates from the desired track. That signal may be masked by instrument error, or electrical/mechanical failure of navigation systems, but the error still exists and can be checked by visual lines of bearing to navaids, or celestial fixes, etc.

The heart of navigation control model then, is the human decision process of determining if there is an error, and how much action is required to reduce the error. Given that an error exists in the difference between actual course and desired track, that error can either be detected or continue to go unrecognized.

If the difference error is not detected then causality is constrained to the fix or lack thereof. If the difference error is recognized, then there must be a determination of why insufficient action was taken.

7.4.2.a The Difference Error is Recognized

The possible actions which result in grounding after recognizing that the actual course differs from the desired track are:

1. Untimely action: the right action is taken but not in time to preclude an accident.
2. Erroneous action: the wrong action is taken.

It is assumed that all the information is available to the conning officer and the difference error is recognized in sufficient time to preclude a grounding. Hence, untimely or incorrect action in response to the difference error is either a failure of the conning officer to respond sufficiently to the error, or the helmsman to act promptly to the conning officer's orders.

7.4.2.b The Difference Error is Not Recognized

If the difference between the actual course and the desired track goes unrecognized, then the failure lies solely with the conning officer. Recall that the conning officer must compare all of the following:

1. Position Sensors: gyro, compass, lookout, radar errors.
2. Position Measurements: procedural errors in taking lines-of-position.
3. Position Estimates: procedural errors in dead-reckoning.

The breakdown in the loop occurs in the proactive process which must be initiated by the conning officer. Typically causality lies in inattention. The NRC listed inattentiveness as the primary cause of maritime accidents [45]. But there are other reasons which may cause a conning officer to be distracted from his duties, and these were outlined in chapter 5.

7.5 Summary of the Course Proceeding down an Unsafe Track

Figure 7-7 summarizes the fault tree for the actual course proceeding down an unsafe track. Basically, the faults occur because of either planning errors or piloting errors.

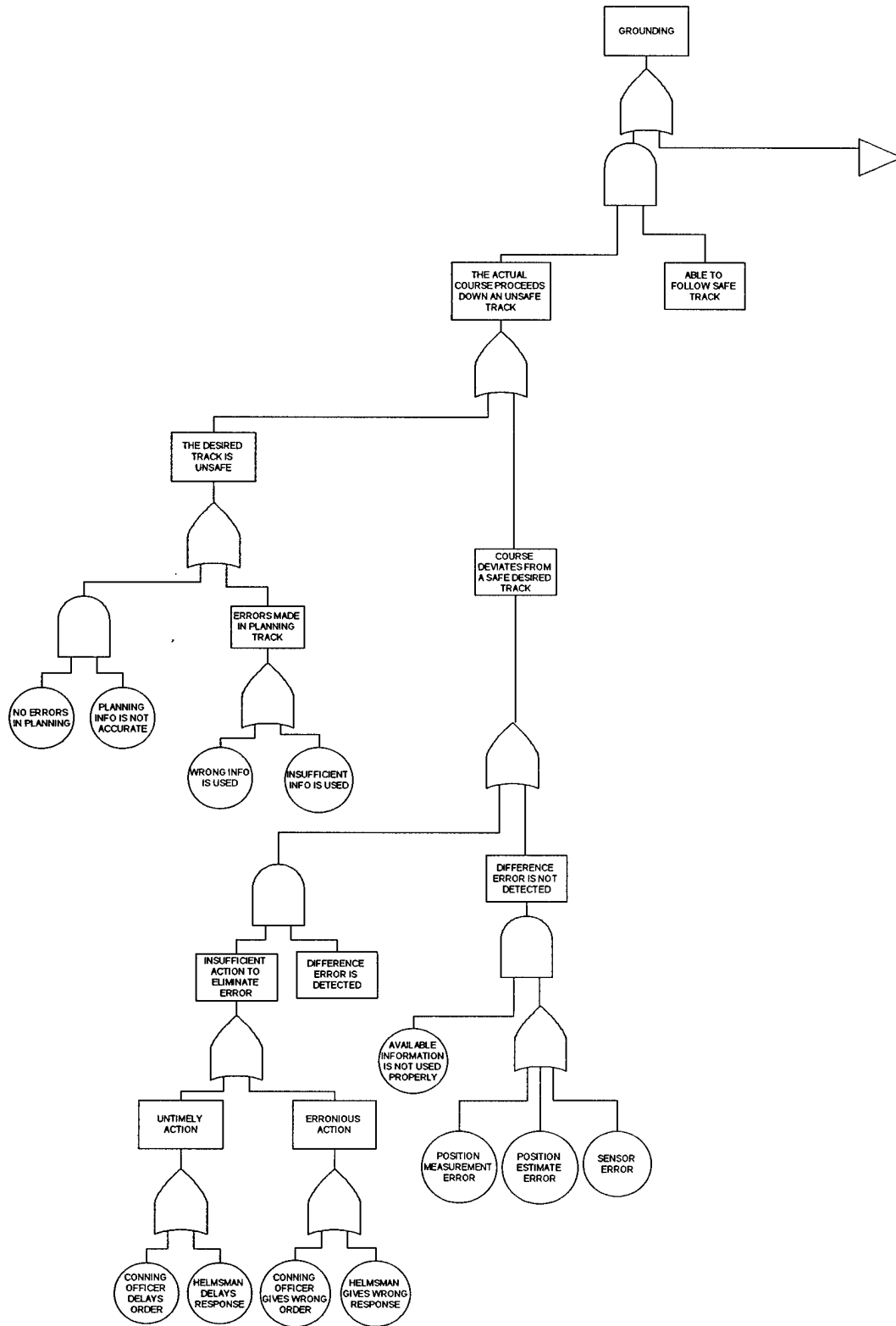

Figure 7 - 5: Fault Tree for Actual Course Proceeding down an Unsafe Track

7.6 Unable to Steer the Ordered Course

The correct course is known but the ship that is unable to steer that course. In this case, the ship is necessarily subjected to a number of parallel factors. All of the following must occur:

1. Lost way: the ship has lost its ability to be effectively controlled
2. Unsafe wind/current: when the ship has lost way, there must be the necessary wind/current to force the ship into the grounding situation.
3. Anchor failure: given that the ship is unable to dynamically control its course, the anchor must fail allowing the environment to control the inevitable.
4. Assistance failure: in addition to the above, there must be a failure of assistance to prevent the grounding.

Figure 6-14 shows the partial fault tree for the inability to steer the correctly ordered course.

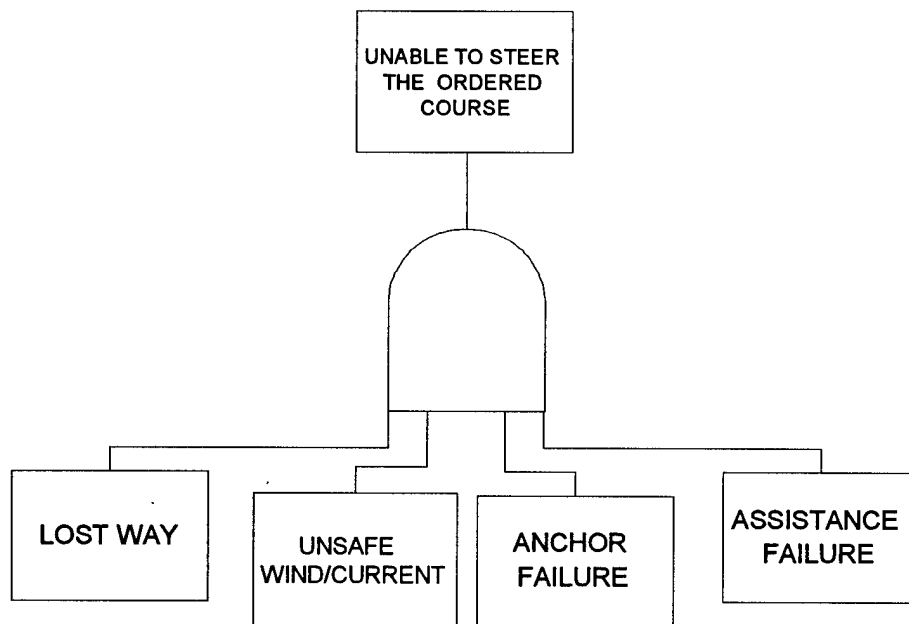

Figure 7 - 6: Partial Fault Tree for the Inability to Steer the Ordered Course

7.6.1 The Ship has Lost Way

For the ship to have lost way it is no longer able to be controlled. This would imply that the ship has lost steering or propulsion. Without getting into the details particular to a specific ship, failure of these mechanical systems can be attributed to maintenance, operation, or material failure. Additionally, given a material failure, the crew is unable to repair the failure before the ship intersects the hazard.

7.6.2 Unsafe Wind/Current

For the ship to encounter a grounding given that it has lost way, it must be forced into the hazard by the wind/current. Many ships lose way while at sea, yet never encounter an accident. It is essential that the environment force the ship into the hazard for the hazard to occur.

7.6.3 Anchor Failure

Tankers will have two anchors. Anchors on large tankers can weigh as much as 50,000 pounds each. But as ships have gotten larger, the anchors have not done so proportionately. The ratio of the anchor weight to the deadweight tonnage has dwindled from about 0.6 to 0.2 [8]. The anchors of large tankers are suitable for anchorage in designated areas, but with any significant way on the ship when dropping anchor, the momentum becomes too great for the anchors to handle.

As a mechanical system, the anchor system failure is subject to the same causality as the propulsion and steering systems; maintenance, operational, and material failure. Additionally, consideration should be made for the case when the anchor is not operated at all. Many vessels have run aground when prudent letting-go of the anchor would have prevented the catastrophe. There are also times where the environmental conditions preclude effective

anchor usage. The ocean bottom either does not lend it self to holding the anchor or the depth gradient is too steep.

7.6.4 Assistance Failure

Tugs or salvage ships can be essential to preventing a catastrophe. The availability and functionality of assist ships is particular to a given port. Implicit failure of assistance occurs if it is not requested. Once requested, the failure can occur if the assistance does not arrive, or if the assistance is unable to put the ship on a safe track. The inability of the assist ship to put the damaged ship on a safe track can be caused by either the assist ship arriving too late, operational errors in securing a tow line, or the assist ship is too small to prevent the damaged ship from grounding.

7.7 Summary of Ship Unable to Follow a Safe Track

Figure 7-9 shows the fault tree for the grounding where the ship is unable to follow a safe track.

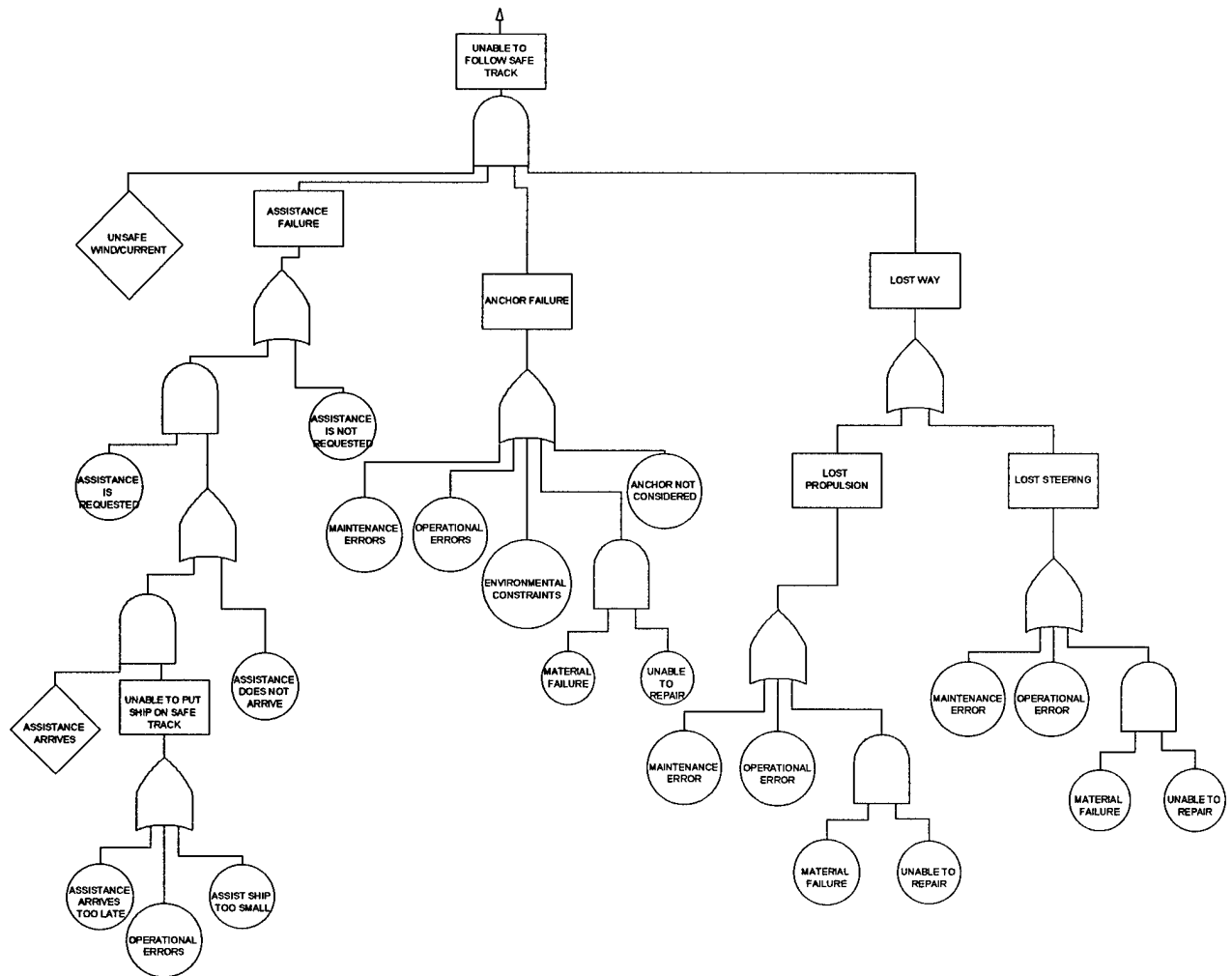

Figure 7 - 7: Fault Tree For Ship Unable to Follow a Safe Track

7.8 Summary

The use of a fault tree to ascertain the areas of risk are essential to an overall risk assessment. Starting from the hazardous outcome, or top-event, and logically progressing downward through sequential levels of causation, the fault tree points to system weaknesses by deductively determining the sources. Once this systematic approach has developed all the root causes for groundings, the result is a qualitative assessment.

The fault tree is a way of decomposing the event, not a way of explaining why. As such, the grounding fault tree is a logical model representing a qualitative characterization of

the system. The postulated fault events in the grounding fault tree are not exhaustive. Deductively and inductively, they represent the most likely events.

Chapter 8 Applications

8.1 Validation

To validate the utility of the fault tree previously developed, the following paragraphs outline some well documented groundings. The fundamental elements of the groundings are then taken from the fault tree. Sources for the grounding descriptions are taken from Cahill, Perrow, and Moore.

8.2 The *Torrey Canyon*

The *Torrey Canyon*, en route from the Persian Gulf to the United Kingdom, ran aground on March 18, 1967 on the Seven Stones shoal between the Scilly Isles and the Southwest coast of England.

As the *Torrey Canyon* prepared for arrival in Milford Haven, England, her draft was slightly over the limit for the port and the ship required some cargo shifting to achieve the minimum draft. The cargo shifting was estimated to take about 5 hours, and the Master felt constrained by time in order to make high water at Milford Haven by 2300 on March 18th, 1967.

The last celestial fix was taken less than 300 miles south of the Scilly Isles and showed to ship to be on the intended track. Prior to the Master retiring for the evening, he left orders to steer 018° at approximately 15 knots. He was to be called when either the ship came within radar landfall, or 0600, whichever came first.

The intended track of the *Torrey Canyon* was to pass west of the Scilly Isles before turning east to approach Milford Haven. There was no authorization in the Master's order to allow for set or drift, even though the winds were from the Northwest at about 5 knots with a moderate sea.

Radar landfall of the Scilly Isles was attained at approximately 0630. But the islands appeared off the port bow, implying that the wind/current had set the ship to the east of the intended track.

When the conning officer (the Chief Officer) noticed the difference error, he altered course to 006° and called the Master to inform him of the course change. There was a documented strained relationship between the Master and the Chief Officer, and when the Master was informed of the course change, he asked if the original course would take the ship right of the Scilly Isles. The conning officer quickly answered "yes", and the Master ordered the ship to the original course. The conning officer had not made a correct assessment, but returned the ship to the original course and shifted to hand steering.

When the Master came to the bridge at 0700, 28 miles from where it would eventually ground, he still had time to accurately assess the situation. But that assessment would not take place. The Master had decided to pass between the Scilly Isles and the Seven Stones. Still, no accounting was taken for set or drift, and a copy of the Sailing Directions for the Scilly Isles was not on board (the Sailing directions would have advised against this action).

As the ship approached the Seven Stones, the method of obtaining a fix was by a single bearing and radar range. This method of fixing a ship is imprudent and subject to large errors. As a result, no on board knew the actual position of the ship.

To further complicate the situation, the Master became distracted with a number of fishing vessels. And while it is judicious to keep the helm in a manual steering, mode, the Master made two course changes and switched the helm back to automatic.

As the ship passed the northern most Scilly Isles, the plan was to turn to port and leave the Seven Stones to starboard. From the 0840 fix, the Master ordered a course of due North. As the Master realized the hazardous situation, there was confusion in trying to return the helm to manual. At 0850 the *Torrey Canyon* ran aground.

Utilizing the fault tree to analyze this accident, one can see that the ship is able to follow a safe track but it proceeds on a course down an unsafe track. While the ship was following the unsafe track, there were failures to detect any difference error imposed by the set and drift of the ship. When the *Extremus* situation was realized, there was a delay in ordering manual steering and untimely response of the helmsman to respond. The following summarizes the mishap:

1. Errors made in planning track: insufficient information was used to determine the desired track. The Sailing Directions for the Scilly Isles were not on board, current tables were not referenced, and there was no accounting for set and drift.
2. Difference error was not detected: Errors were made in position measurements, position estimates, and there was a failure of the conning officer to recognize the error.
3. Insufficient action was taken to eliminate the error: there was untimely action on behalf of both the conning officer to order manual steering , and the helmsman was delayed in switching to manual steering.

Figure 8-1 highlights those portions of the fault tree which represent the grounding of the *Torrey Canyon*.

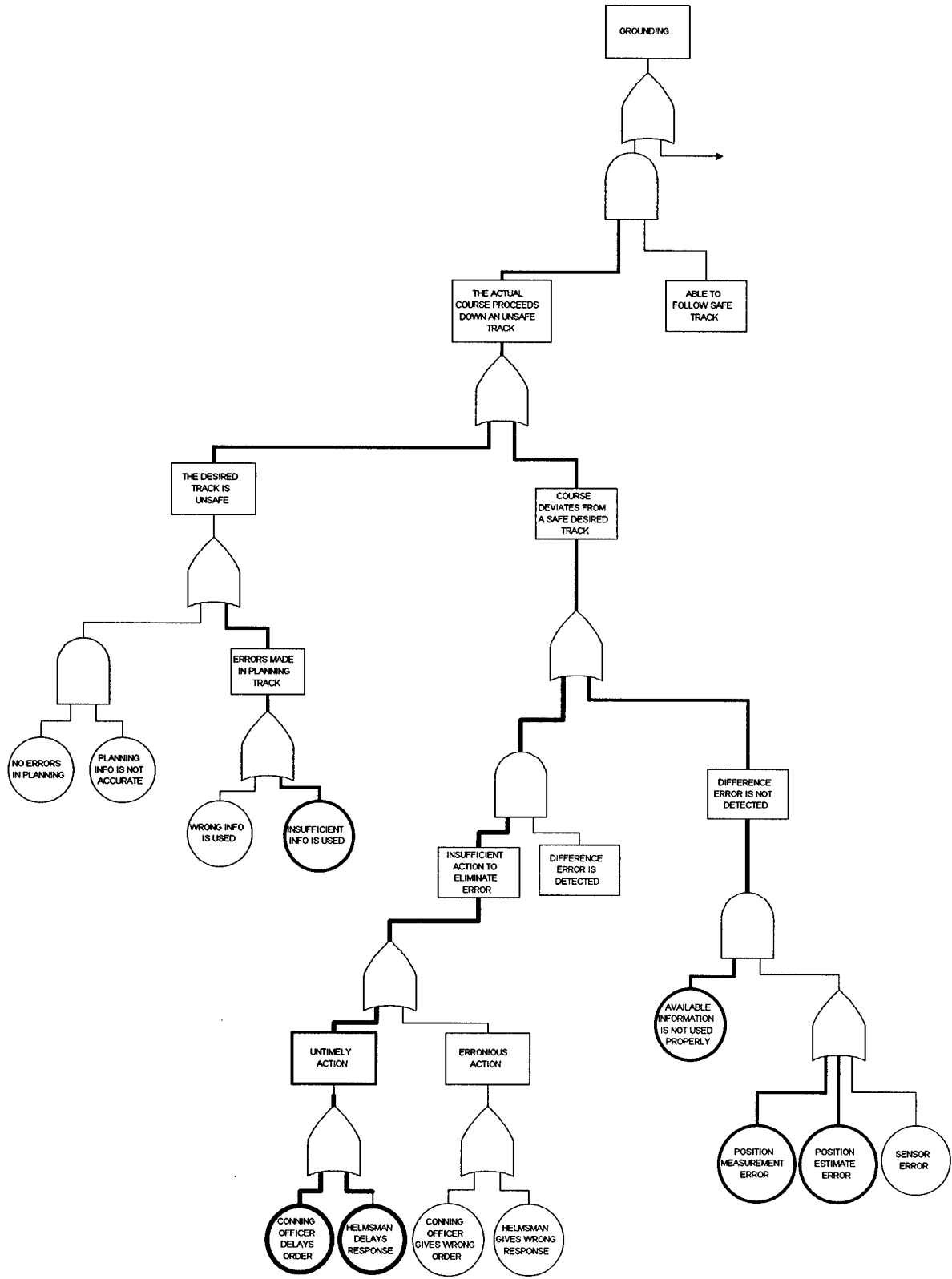

Figure 8 - 1: Fault Tree for *Torrey Canyon* Grounding

8.3 The *Transhuron*

The *Transhuron* was a reconfigured T-2 tanker. When the ship was "jumboized", in 1966, air conditioning was installed, but the air conditioning piping was installed in the vicinity of the main propulsion switch board. In spite of regulations prohibiting piping runs in the vicinity of switch boards, the installation was approved, and passed inspection by the USCG. The air conditioning system was subsequently modified and an iron nipple was placed on a bronze condenser to hold a gauge. The dissimilar metals on the condenser accelerated corrosion. When the nipple failed, water was sprayed onto the main propulsion switchboard resulting in a loss of propulsion. The *Transhuron* subsequently grounded and broke up near Kitlan Island, in the Laccadives, off the southwest coast of India.

The *Transhuron* was *en route* from Bahrain to the Philippines loaded with over 100,000 barrels of fuel oil. On September 18, 1974, the ship got under way with the fathometer broken, and a day later the ship's only radar failed. The ship was reduced to rely upon celestial navigation and a gyro compass for navigation.

On September 24, at 0300, the nipple failed and shorted the main propulsion switchboard. There were ineffectual attempts to stop the machinery, but none to deenergize the equipment. The fixed and semi-portable CO₂ systems failed. The crew was forced to use small portable CO₂ bottles to fight the fire. Only then, was consideration given to deenergizing the equipment. With power secured, the fire was quickly put out, but damage to the propulsion control unit was beyond repair.

The Master immediately sent an urgent message to the head office in New York, via a relay at Cochin Radio India, informing them of the situation and requesting tug services. A series of fixes were taken and it was ascertained that the ship was 120 miles northwest of Kitlan Island, and drifting directly towards the island at a rate of 2 knots.

When no reply was received from New York, the Master sent another urgent message via the Cochin relay. Meanwhile, several vessels had offered assistance, but the Master was reluctant to take responsibility. The head office reply was received at 1600 on the 25th, nearly 31 hours later. It was then that the *Transhuron* became aware that Cochin Radio did

not recognize urgent messages, and all messages were handled in the order received. The head office remained unaware of this situation.

The weather had degraded, making it impossible to fix the position of the ship. Near midnight of the 25th, a Norwegian tanker informed the *Transhuron* that Chetlat Island was just under 8 miles from their present position. This information showed that Kitlan Island was little more than 20 miles to the southeast and the ship was continuing to drift towards it. Still, the Master insisted on waiting for direction from the head office before summoning help.

On the morning of the 26th, Chetlat and Kitlan Islands were within sight. Through bearing lines, the ship was determined to be 15 miles from Kitlan Island at 0620. With an inevitable grounding less than ten hours away, and still no word from the head office, the Master attempted another message.

At 1100 the Master finally decided to take unilateral action and put out a general distress call. A number of ships responded, but all were over 100 miles away. At 1245 another distress call was sent, this time the nearest response was from the Japanese ship, *Toshima Maru*, 45 miles away.

Had the fathometer been working, the *Transhuron* could have ascertained an anchorage, but without either a fathometer or detailed charts of the area, the ship was unable to determine an anchorage and resolve the severity of the situation.

When the *Toshima Maru* arrived at 1600, it attempted to get a line over. The 3rd Mate of the *Toshima Maru* was injured and the Lyle gun damaged when attempting to shoot the line over to the *Transhuron*. The *Toshima Maru* decided to abandon the rescue and proceed to the nearest port for medical attention.

The Master of the *Transhuron* persuaded the *Toshima Maru* to attempt to tow them a half mile away from the Island. It was now nearly 1800. As the *Toshima Maru* approached the *Transhuron*, at 1812 the *Transhuron* grounded. Only now did the Master order the anchor walked out.

The *Transhuron* subsequently was abandoned and broke up with ship and cargo a total loss.

The fundamental elements resulting in the grounding of the *Transhuron* are a result of the ship being unable to follow a safe track:

1. Lost way: the ship suffered a loss of propulsion due to a material failure.
2. Necessary wind/current: the wind/current caused the Transhuron to drift into the shoal water in the vicinity of Kitlan Island.
3. Assistance failure: assistance arrives, but there are operational errors in getting a line over, but even the line had gotten over, it is questionable that there was enough time to preclude the grounding. The delay in requesting assistance seems to motivate the assistance failure.
4. Anchor failure: anchor failure is due to not considering dropping the anchor. Not having a fathometer, it might have been prudent to walk the anchor out such that it would hold once the depth permitted.

Figure 8-2 highlights the fault tree for the grounding of the *Transhuron*.

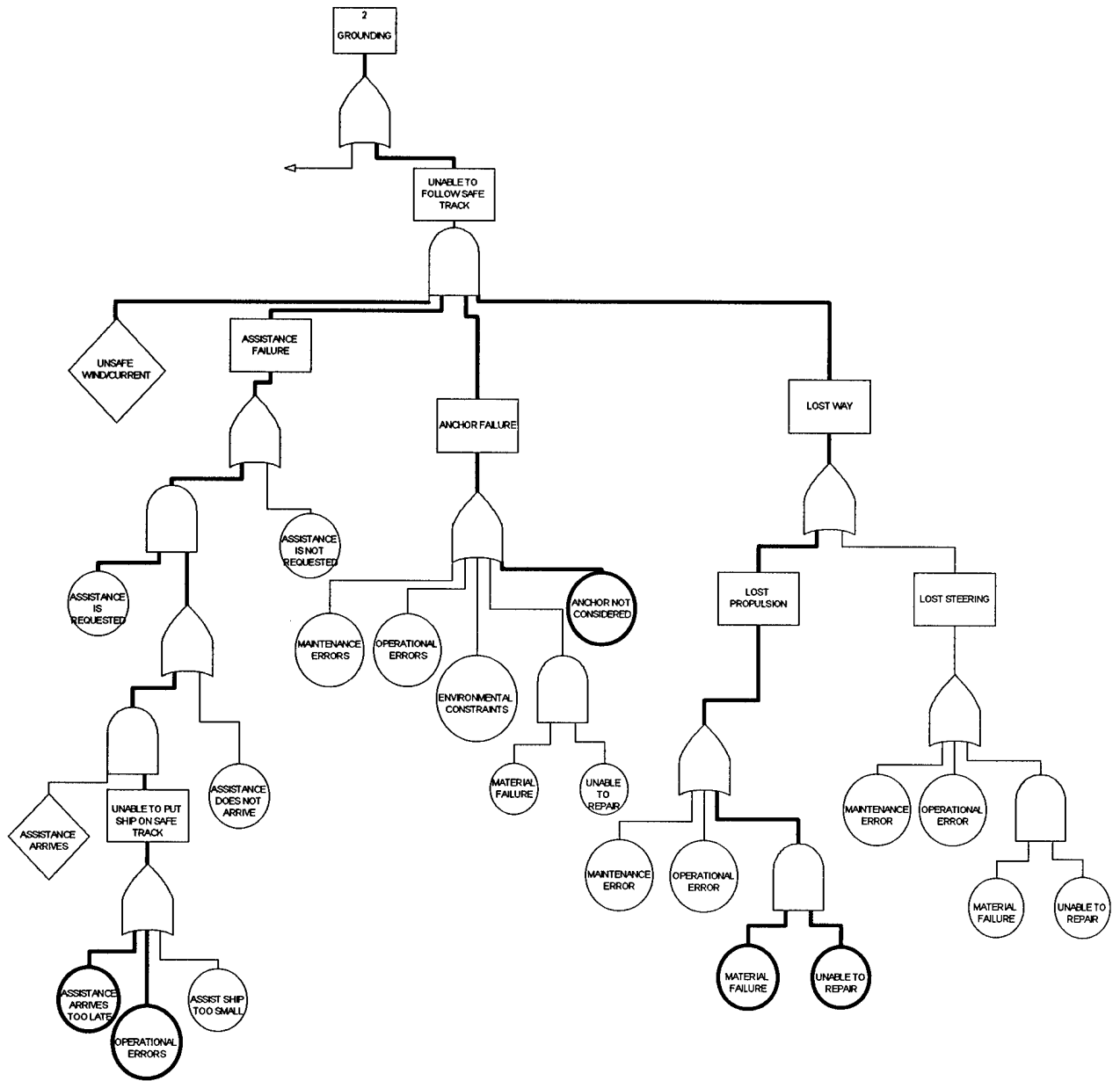

Figure 8 - 2: Fault Tree for *Transhurion* Grounding

8.4 The *Amoco Cadiz*

On March 16, 1977, the *Amoco Cadiz* grounded east of Ushant, and subsequently broke up on the rocks of Roche De Portsall on the Brittany Coast.

Sailing in gale force winds, the *Amoco Cadiz* lost steering at 0946 in the Ushant traffic separation scheme. The Master investigated the damage with the Engineering Officer. The seriousness of the situation should have been realized, but when the Master returned to the bridge at 1020, he did not think of either summoning for assistance, or dropping anchor, despite being only 10 miles from a lee shore.

At 1100, the *Amoco Cadiz* was broadside to the wind and seas, approaching the coast of Brittany. The Master finally realized the seriousness of the situation and requested assistance from the port control. The tug *Pacific* was contacted, but no mention was made of a larger tug, *Simson*, belonging to the same owners and nearby.

The *Pacific* arrived on the scene at 1220. but disagreement on salvage terms delayed the tug from getting a line over to the *Amoco Cadiz*. A line was finally over at 1400 and the *Pacific* attempted to swing the bow over to a more westerly heading. But the *Pacific* proved to be inadequate. The *Amoco Cadiz*'s southeast drift was checked, but the wind had shifted to the northwest and the vessels were being moved east. Finally the tow line parted at about 1600.

With the coast visible and about 6 miles away, the Master attempted to slow the drift by putting the engines full astern. The effect was to swing the stern into the northwest wind, while the ship drifted northeast, parallel to the coast.

Seeing the effect, the tug captain decided to attempt a tow from astern. To rig from the stern necessitated stopping the engines, and thereby, allowing the *Amoco Cadiz* to continue its drift straight for the rocks. The *Amoco Cadiz* stopped her engines at about 1900, but rough seas precluded getting a line from the tug to the *Amoco Cadiz*.

Earlier, the Master had ordered that the port anchor be made ready for letting-go. After an hour of drifting, and tug still struggling to get a line over, the Master ordered the port anchor dropped. But the momentum of the ship prevented the anchor from holding, and the seas prevented getting the starboard anchor ready. It was not until 2030 that a line was over from the tug.

At 2055 the tow was secure and able to begin. But at 2104 the *Amoco Cadiz* grounded aft. The Master ordered all power secured to minimize the chance of an explosion. With the hull holed, but ship still moving in seaway, the ship struck ground again at about

2130. The *Pacific* continued to attempt pulling the *Amoco Cadiz* but the line parted at

2215. The situation became hopeless. The *Simson* arrived at 2300 but too late to offer any assistance. Subsequently, all hands were evacuated and the ship broke up.

In evaluating the *Amoco Cadiz* grounding, the ship was unable to follow a safe track due to having lost way with an anchor failure, an assistance failure, and the required wind and current to force the ship onto the rocks. The fundamental elements of the grounding are as follows:

1. Lost steering: a material failure of the steering system prevented the ship from making way.
2. Anchor failure: there were operational errors in that the starboard anchor was never made ready for letting go, and there was a material failure of the port anchor.
3. Assistance failure: the assistance was inadequate in that the assist ship was too small to put the *Amoco Cadiz* on a safe track.

The fault tree for the *Amoco Cadiz* grounding is shown in Figure 8-3.

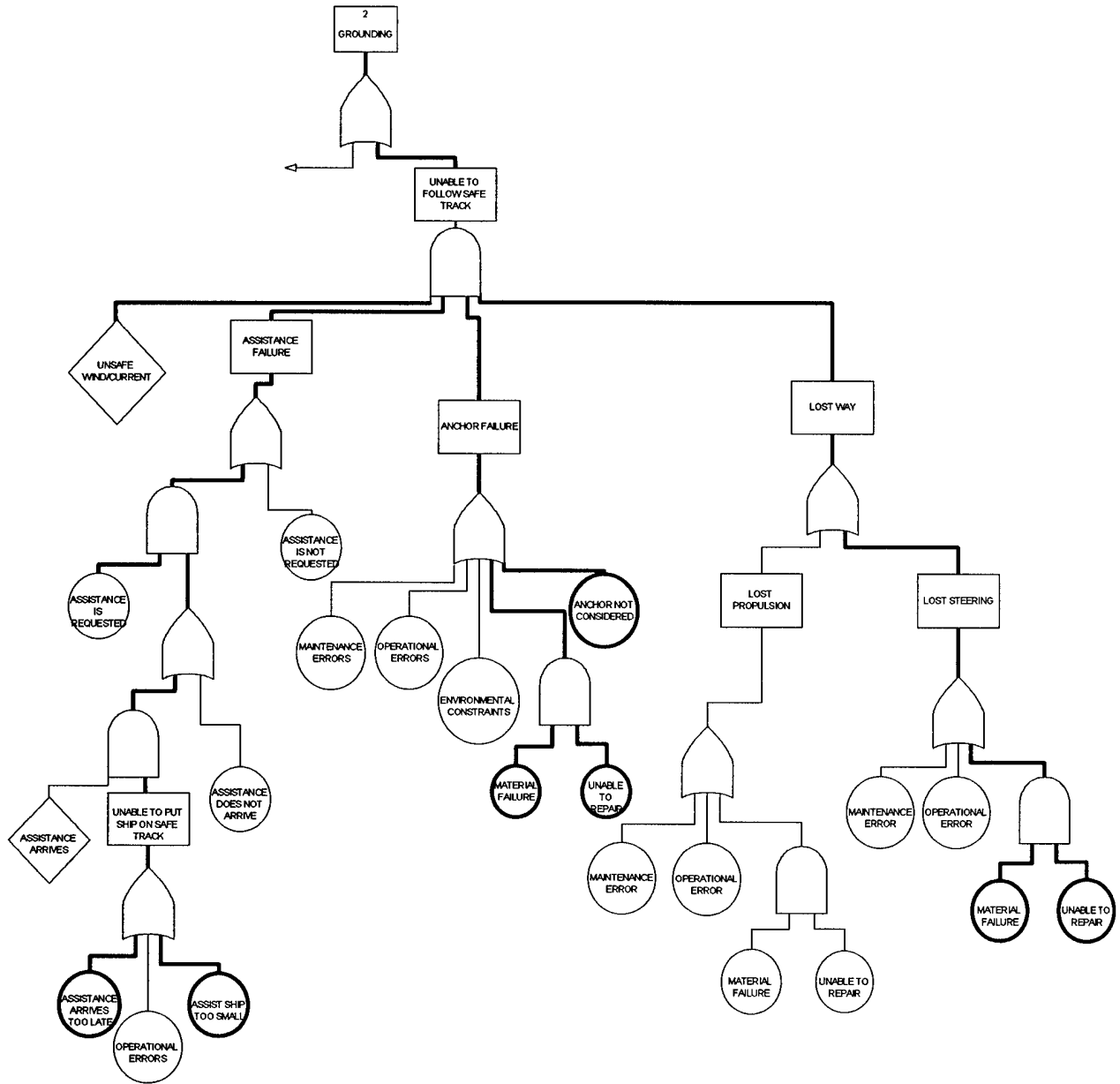

Figure 8 - 3: Fault Tree for the Grounding of the *Amoco Cadiz*

8.5 The *Exxon Valdez*

At 2112, March 23, 1989, the *Exxon Valdez* got underway from the Valdez Alaska, heading for Long Beach California. There were reports of ice flows from the Columbia Glacier blocking part of the traffic separation scheme. The Master and the Chief Engineer had

discussed the possibility of delaying the departure until daylight, but the Master decided to stick with the evening's departure schedule. Once underway, the ice flows were verified with the ship's radar.

At 2324, the pilot departed the ship and the Master notified the VTS of the pilot's departure and the intention of diverting from the traffic separation scheme. The Master's intention was to continue outbound in the inbound lane to avoid the ice flows. The VTS reported that no inbound traffic would be encountered.

While the 3rd Mate was assisting the pilot off the ship, the Master was alone on the bridge with the helmsman. Shortly after the pilot departed he ordered a course of 200°, and an increase in speed. He noticed on the radar that more ice was further east, so he ordered a course of 180°. After the ship steadied up on the ordered course, the Master ordered the helmsman to shift to automatic pilot.

When the 3rd Mate returned to the bridge, the Master told him that the intended plan was to remain on a course of 180° until the ship cleared the ice just below Busby Island. The turn should commence once the ship was abeam of Busby Island. Feeling satisfied with the 3rd Mate's competency, the Master left the bridge.

At 2355, the Busby Island light was abeam of the *Exxon Valdez*. The ship was still accelerating to sea speed. The helmsman was relieved and only upon reporting his relief did the 3rd Mate realize the ship was in automatic pilot. The helmsman was ordered to place the ship back into hand steering and the 3rd Mate became preoccupied with the radar screen assessing the ice flow.

The ship had passed the Busby Island light. At 2356, the 3rd Mate ordered a 10° right rudder and called the Master to inform him that he had started the turn. He did not tell the Master that he had passed Busby Island light before executing the maneuver. Two minutes later, the 3rd Mate realized that the ship had not swung appreciably. He ordered the helm to increase the rudder angle to 20°. The lookout reported a red flashing light to starboard. The 3rd Mate ordered a hard right rudder. The ship began to rapidly swing, and at 0004 the heading had reached 234°, but the helmsman was anticipating an ordered course between 235 and 245, and he began to check the swing of the ship. At 0007 the *Exxon Valdez* was hard aground on Bligh Reef.

The *Exxon Valdez* held an unsafe track, even though it was capable of following a safe track. The planning was appropriate, and the skill necessary to execute the plan was not beyond what should of been expected. Prudence may have meant delaying the underway until daylight, but common sense dictated that the Master not leave the bridge. As the course deviated from a safe track after it came abeam of Busby Island light, the fundamental error was:

1. Insufficient action to eliminate the error: untimely action was taken by the conning officer to order a course change and, an untimely response was taken by the helmsman. There seem to be some confusion in shifting to manual steering, and the helmsman checked the swing of the ship, anticipating an ordered course.

Figure 8-4 highlights the fault tree for the grounding of the *Exxon Valdez*.

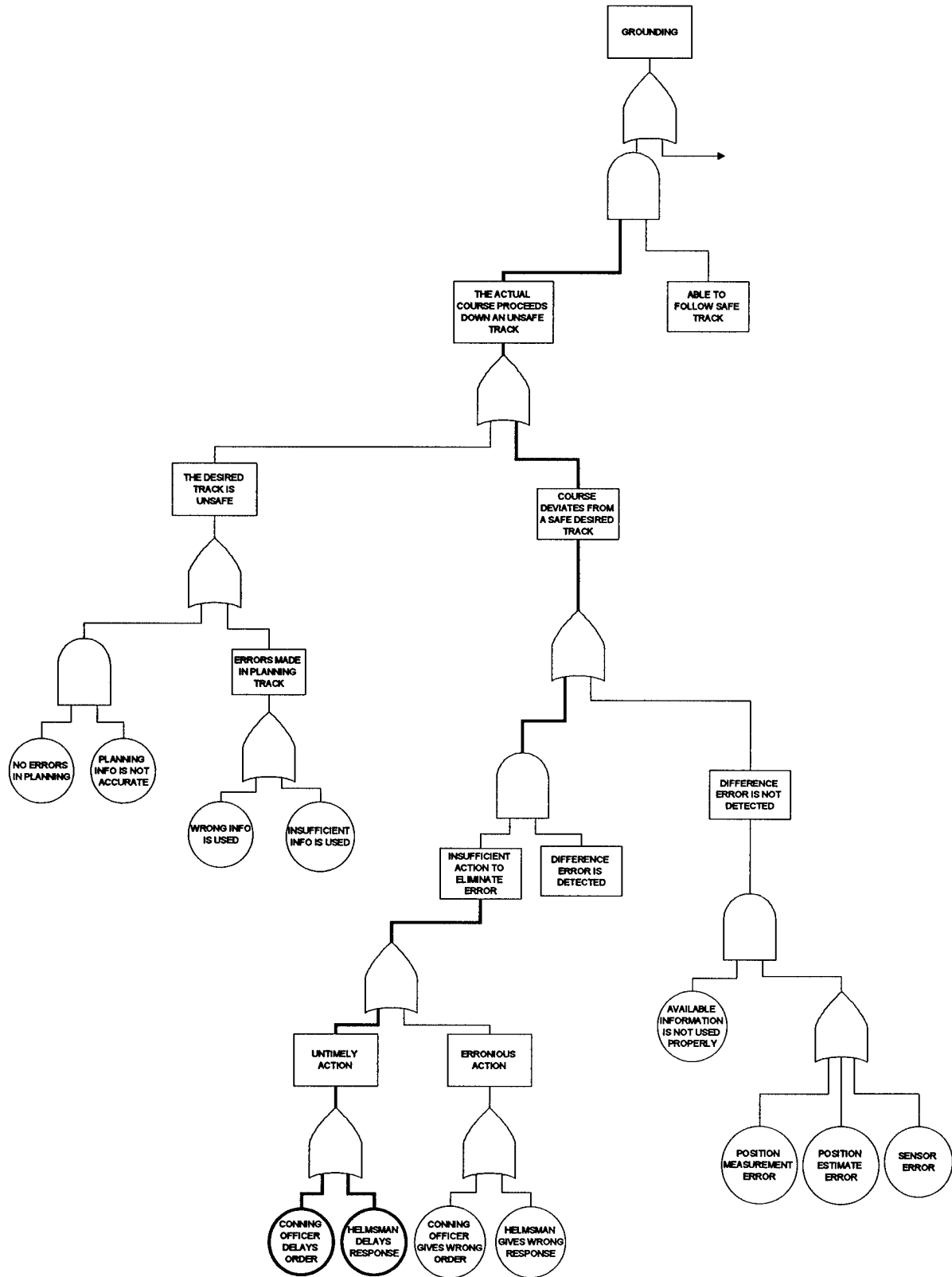

Figure 8 - 4: Fault Tree for the Grounding of the *Exxon Valdez*

8.6 The *Braer*

On January 3, 1993, with a severe weather forecast, the *Braer* got underway from Mongstad, Norway with a full load of light crude to deliver to Quebec. As soon as the ship was in open ocean, it began to encounter heavy seas. Severe rolling and pitching required the speed to be limited and the deck was regularly awash by the waves. By midnight of the first night at sea, the speed made good was only 3 knots.

Just after midnight, the boiler high and low level alarms began sounding due to the severe pitching and rolling. To prevent an automatic shutdown, the 2nd Engineer adjusted the water level controller but failed to inform any of his superiors.

On the morning of the 4th, the Chief Engineer and the Chief Officer became concerned about some pipes that had been stowed on deck. They investigated and found that in fact, the pipes were loose and rolling around on deck. The loose pipes were reported to the Master, but he decided to wait until the weather cleared to stow them. No one seemed to appreciate the fact that the pipes were rolling against the air intake of the ship's fuel tanks.

On the evening of the 4th, the auxiliary boiler began malfunctioning. This boiler was necessary to pre-heat the heavy oil used for the main engines. Thus, until repairs could be effected, the main engines were switched to diesel oil.

It was discovered that the diesel oil supply to the auxiliary boiler was contaminated with seawater. As attempts were made to drain the seawater, it was discovered that the diesel supply to the main engines and the generator was also contaminated. Drainage of the seawater was continued, and the Master notified, but the heavy pitching and rolling precluded the settling tanks from being effective.

At 0440 on the morning of the 5th, the main engine stopped. A short time later the generator stopped resulting in a loss of all main power. Efforts to drain the fuel tanks continued but no one recognized the source of contamination as the broken air intakes on the deck. The attempts to drain the water by transferring oil from storage to settling tanks had contaminated all of the fuel on board.

The *Braer* was 10 miles south of Sumburg Head, the southern tip of the Shetland Islands. At 0515, the Master reported his situation and position to the Coastguard. The Mas-

ter requested tug assistance but would not commit to any financial agreement without approval of the head office in New York. The Master was advised that it would take 2 to 3 hours for a tug to reach *Braer* once a commitment was made. What the Master failed to check was his drift. The *Braer* was drifting north at 2 knots directly toward the Shetland Islands.

Nearly 2 hours after the engines had stopped the Coastguard had gotten permission from the *Braer's* managers in New York. Meanwhile, the *Braer* had drifted to within 6 miles of the coast, yet, the Master still believed he was 10 miles away.

The Coastguard immediately requested tugs and initiated a helicopter evacuation of the *Braer's* crew. When the helicopter arrived at 0640, the *Braer* was rolling heavily in severe seas with winds gusting at 65 knots. The engineers were still trying to restore power, but with the vessels drift rate, it was decided to abandon the ship before the tug arrived. The helicopter evacuation was complete at 0830 and *Braer* was about 1 mile from the coast.

Shortly after the ship was abandoned, the northerly drift ceased, and *Braer* began to drift west. During the evacuation, dropping the anchors was apparently never considered. Only after all personnel were off the ship was there some discussion of placing personnel back on the ship to drop the anchors. But the foremast prevented the helicopter from operating in the vicinity of the bow and the idea was rejected.

When the tug arrived, no one was on *Braer* to secure the towing lines. The ship began to drift north toward the shore again. Volunteers were landed on the stern of *Braer* to secure the lines, but they were unsuccessful due to fouling of the messenger lines. The *Braer* subsequently grounded around 1130 January 5, 1993.

The *Braer* was unable to follow a safe track. The fundamental elements of this grounding are as follows:

1. Lost way: the ship lost propulsion due to a material failure of the fuel tank air intakes on deck.
2. Necessary wind/current: sufficient wind/current existed to cause the northerly drift into the Shetland Islands.
3. Anchor failure: the anchor was never considered until the ship was abandoned.

4. Assistance failure: the delay imposed by waiting for permission from New York caused the tugs to arrive too late.

Figure 8-5 shows the fault tree for the grounding of the *Braer*.

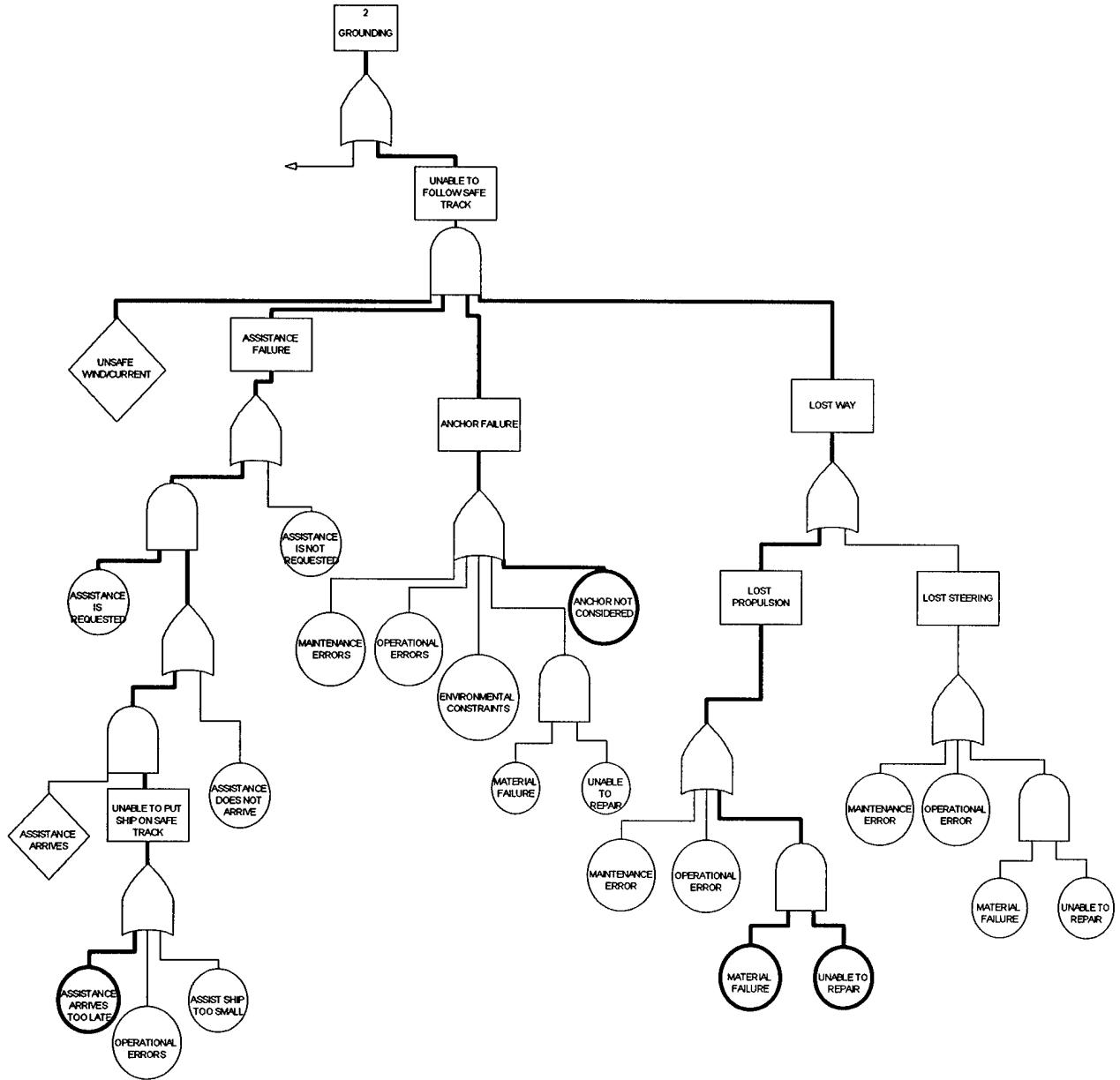

Figure 8 - 5: Fault Tree for the *Braer* Grounding

8.7 Fault Tree Utility

The application of the aforementioned tankers to the grounding fault tree has shown its utility. As a qualitative tool, the fault tree has been utilized to identify the system faults.

As a model, all of the case studies fit nicely into the fault tree, but the fault tree does not represent a complete picture of events. There are a number of factors that influence the fundamental events that lead to a grounding. The fault tree does not tell the whole story. Research into the probabilities of the root causes will allow a quantitative evaluation to continue on to the next step in the PRA.

Chapter 9 Conclusion

9.1 The Next Step

Recall the required tasks necessary to perform a PRA of the tanker industry. Table 9-1 recapitulates the required tasks.

Table 9 - 1: Tasks Required to Perform a PRA of the Oil Tanker Industry

Step	Task
1:	Identify the combination of system failures which can lead to an accident.
2:	Determine the probability of each failure.
3:	Determine the probability distribution of oil outflow for each failure.
4:	Determine the transport and fate of the released oil for the prevailing weather conditions.
5:	Assess the economic and environmental effects.
6:	Determine the overall risk assessment for each of the failure sequences identified.

Only the first step has been accomplished, and only for tanker groundings. The next step in the performance of the PRA for tanker groundings is to assign probability values. It is necessary to analyze each of the fundamental causes in the fault tree and determine the significant factors that must be considered. Once considered, those factors must be assigned probability values. This is the most critical portion of the PRA and it will require careful consideration.

There are a number of methods that can be used to integrate human failure factors into the PRA, each of which has characteristics that are beneficial. Since there are limitations and difficulties in current human reliability analysis, there should be a careful consideration of the available methods prior to integrating the human factors. Table 9-2 classifies the categories of common human reliability models. There is no single model that captures all important human errors and predicts their probabilities [39].

Table 9 - 2: Human Reliability Analysis Models

<u>Simulation Models</u>	<u>Expert Judgment Models</u>	<u>Analytical Methods</u>
Maintenance Personnel Performance Simulation	Paired Comparison	Technique for Human Error Rate Prediction
Cognitive Environment Simulation	Direct Numerical Estimation	Human Cognitive Reliability Correlation
		Time Reliability Correlation

9.2 Caveat Emptor

When developing a PRA for oil spills it is important to recognize the areas of uncertainty. The PRA is a discrete analysis. Therefore, it is unable to account for the infinite number of possibilities. Ideally, a PRA considers all the important aspects that lead to the undesired event, but there is the possibility that important contributions have been overlooked.

With any model, there are uncertainties due to the necessary approximations made in developing the model. The human failure factors are typically the largest source of uncertainty in a PRA. Another source of uncertainty is inherent with the complexity of the system. There is uncertainty in system behavior sensitivity due to the subjective nature of the analysis.

Despite the uncertainties, it is important to develop the probabilistic risk so that perceived risk does not produce irrational behavior. The performance of a risk analysis reduces the uncertainty concerning some of the elements of risk so the resources can be better allocated.

9.3 *Précis*

As the demand for oil continues to rise, there are expectations that tanker demand will increase. Estimates from 1985 indicate that tanker accidents contribute 400,000 tons of oil pollution to the seas. There is some evidence that this value has gone down, however, unless there are appropriate steps taken, it can easily be conjectured that pollution will rise with the ton-miles of tanker cargo.

The maritime industry has historically been known for risk taking, but the consequences of failure have become enormous. International and domestic attempts at regulation have been discrete and reactionary. The maritime culture, economics, and regulatory bodies all contribute to create a system that can be characterized as error-inducing. There has been little effort to characterize the system as a whole and determine the areas offering the greatest potential for risk reduction.

Chapter 4 outlines the steps required to perform an overall risk assessment. A complete PRA can allow all parties to focus on those areas offering the greatest potential for reduction.

The first step of a PRA is to identify system failures and sequences. The fault tree for tanker groundings was developed to determine the failures and sequences. The utility of the fault tree was then confirmed from case studies of well-documented groundings.

The bottom layer of the fault tree describes the fundamental causes for tanker groundings. Qualitatively, human failure and individual error are significant in the progression of events leading to a tanker grounding.

Despite the qualitative nature of the analysis, it does point out areas which can offer significant reductions in the risks associated with tanker operations. Many of the system failures are a result of technology and management

Once the PRA is completed, by allocating resources in the areas that are risk relevant, rather than trying to alleviate all conceivable hazards, the performance of a risk analysis of and by itself can reduce risk as knowledge and awareness are gained [15]. Additionally, if the

process of risk assessment is dynamic, the uncertainties will diminish with time. As the NRC states [48]:

Marine safety could benefit from increased use of quantitative and qualitative risk analysis in developing risk reduction strategies. This approach is a proven methodology that could form a solid basis for identifying, developing, and evaluating the risk reduction options

Even though the ratio of oil spilled to oil transported is extremely small, there is plenty of room for improvement. The upshot is that there is momentum in the industry for change. The outlined systematic approach offered by a PRA yields the areas of change to which the industry can focus.

Bibliography

- [1] Ashford N., "An Innovation-Based Strategy for the Environment," *Worst Things First: The debate Over Risk-Based National Environmental Priorities*, Finkel A., Golding D. eds. Resources for the Future, Washington D.C., 1994.
- [2] Aspland J., "Nine Switches of Alertness," *Proceedings of the Marine Safety Council*, Vol. 52, No 3, May-June, 1995.
- [3] Bea R.G., Moore W.H., "Operational Reliability and Marine Systems," *New Challenges to Understanding Organizations*, Roberts K.H., Macmillan Publishing Co., New York, 1993.
- [4] Bea R.G., Moore W.H., "Reliability Based Evaluations of Human and Organization Errors in Reassessment & Requalification of Platforms," International Offshore Mechanics and Arctic Engineering Conference Safety and Reliability Symposium, No. OMAE 94-1272, Feb., 1994.
- [5] Bea R.G., *The Role of Human Error in Design, Construction, and Reliability of Marine Structures*, Ship Structure Committee, SSC-378, Nov. 1994.
- [6] Bole A.G., Dineley W., Nicholls C.E., *The Navigation Control Manual*, William Heinemann Ltd, London, 1987.
- [7] Cahill R.A., *Strandings and their Causes*, Fairplay Publications LTD, London, 1985.
- [8] Cahill R.A., *Disasters at Sea: Titanic to Exxon Valdez*, Nautical Books, San Antonio, 1991.
- [9] Christie D.R., *Coastal and Ocean Management Law*, West Publishing Co., St. Paul, 1994.
- [10] Clark R., "Recovery: The Untold Story of Valdez Spill," *Forum for Applied Research and Public Policy*, Winter, 1991.
- [11] Cowan E., *Oil and Water, The Torrey Canyon Disaster*, J.B. Lippincott Co., New York, 1968.
- [12] Cox S.J., Tait N.R.S., *Reliability, Safety & Risk Management: An Integrated Approach*, Butterworth-Heinemann LTD, Oxford, 1991.
- [13] Davidson A., *In the Wake of the Exxon Valdez: The Devastating Impact of the Alaska Oil Spill*, Sierra Club Books, San Francisco, 1990.
- [14] Dorf R.C., *Modern Control Systems*, Addison-Wesley Publishing Co., New York, 1989.

- [15] Dougherty E.M., Fragola J.R., *Human Reliability Analysis*, John Wiley & Sons, New York, 1988.
- [16] Doyle J., *Crude Awakening: The Oil Mess in America*, Friends of the Earth, Washington D.C., 1994.
- [17] Farrington J.W., "Oil Pollution: A Decade of Research and Monitoring," *Oceanus* Vol. 28 No. 3, Fall, 1985.
- [18] Gardenier J.S., "Ship Navigational Failure Detection and Diagnosis," *Human Detection and Diagnosis of System Failures*, Edited by Rasmussen J., Rouse W.B., Plenum Press New York, 1980.
- [19] Green A.E., *Safety Systems Reliability*, John Wiley & Sons Ltd., New York, 1983.
- [20] Grose V.L., "Technology's Impact on Human Risk," *Proceedings of the Marine Safety Council*, May-June, 1995.
- [21] Gunner T.J., Edwards D.A., *Gunner and Edwards on the Carriage of Crude Oil by Sea*, Lloyd's of London Press, London, 1986.
- [22] Healey T., "Industry Must be Involved," *Proceedings of the Mariners Safety Council*, Vol. 52 No. 2, March-April, 1995.
- [23] Hobbs R.R., *Marine Navigation 1: Piloting*, Naval Institute Press, Annapolis, 1981.
- [24] Hornstein D., "Reclaiming Environmental Law: A Normative Critique of Comparative Risk Analysis," *Columbia Law Review*, Vol. 92, pl 562-633, 1992.
- [25] Jenner B.P., "Risk Control through Quality Management (Future Development and Tools)," IMAS 92, Quality of Shipping in the Year 2000, Nov., 1992.
- [26] Jones R.B., "The Enemy From Within," *Proceedings of the Marine Safety Council*, Vol. 52, No 3, May-June, 1995.
- [27] Katsouros M.H., "Oil Spills", *The Energy-Environment Connection*, Hollander J.M., editor, Island Press, Washington D.C., 1992
- [28] Kelso D.D., Brown M.D., "Policy Lessons from *Exxon Valdez*," *Forum for Applied Research and Public Policy*, Winter, 1991.
- [29] Krier J.E, Gillette C.P., "The Un-Easy Case for Technological Optimism," *Michigan Law Review*, Vol. 84:405, December, 1985.

- [30] Kristiansen I.S., Rensvik E., "Human and Organisational Factors in Safe Operation and Pollution Prevention," IMAS 92, Quality of Shipping in the Year 2000, November, 1992.
- [31] Kristiansen I.S., "An approach to Systematic Learning from Accidents", Paper 11, IMAS 95, Management and Operation of Ships: Practical Techniques for Today and Tomorrow, The Institute of Marine Engineers, 1995.
- [32] Landman R.A., "Why Use Risk-Based Technology?," *Proceedings of the Marine Safety Council*, Vol. 52, No 3, May-June, 1995.
- [33] Lowry I.J., "Improving Mariner/Ship Interaction," *Marine Technology*, Vol 31, No.2, April 1994.
- [34] Maloney E.S., *Dutton's Navigation and Piloting*, Naval Institute Press, Annapolis, 1985.
- [35] Mandler M.B., "Coast Guard Probes Human Factors," *Proceedings of the Marine Safety Council*, Vol. 52, No 3, May-June, 1995.
- [36] Mannschreck W.A., *Analysis of Surface Ship Mishaps*, Naval Safety Center, Naval Air Station Norfolk, 1994.
- [37] Marks A., *Elements of Oil Tanker Transportation*, PennWell Publishing Co., Tulsa, 1982.
- [38] Mielke J.E., "Oil Spills: Is the Perception Worse than the Reality?," *Forum for Applied Research and Public Policy*, Winter, 1991.
- [39] Modarres M., *What Every Engineer Should Know About Reliability and Risk Analysis*, Marcel Dekker, Inc, New York, 1995.
- [40] Mostert N., *Supership*, Alfred A. Knopf, Inc., New York, 1974.
- [41] Moore W.H., Bea R.G., Roberts K.H., "Improving the Management of Human and Organization Errors (HOE) in Tanker Operations," The Society of Naval Architects and Marine Engineers, The Ship Structure Committee, Ship Structures Symposium 93, November, 1993.
- [42] Moore W.H., "The Grounding of *Exxon Valdez*: An examination of the Human and Organizational Factors," *Marine Technology*, Vol. 31, No. 1, January, 1994.
- [43] Moore W.H., Bea R.G., "Management of Human and Organisational Error Throughout a Ship's Life Cycle," Paper 18, IMAS 95, Management and Operation of Ships: Practical Techniques for Today and Tomorrow, The Institute of Marine Engineers, 1995.
- [44] Nalder E., *Tankers Full of Trouble*, Grove Press, New York, 1994.

- [45] National Research Council, Panel on Human Error in Merchant Marine Safety , Maritime Transportation Research Board, *Human Error in Merchant Marine Safety*, National Academy of Sciences, National Academy Press, Washington D.C., 1976.
- [46] National Research Council, Committee on the Effect of Smaller Crews on Maritime Safety, Marine Board, *Crew Size and Maritime Safety*, National Academy of Sciences, National Academy Press, Washington D.C., 1990.
- [47] National Research Council, Committee on Tank Vessel Design, Marine Board, *Tanker Spills: Prevention by Design*, National Academy of Sciences, National Academy Press, Washington D.C., 1991.
- [48] National Research Council, Committee on Advances in Navigation and Piloting, Marine Board, *Minding the Helm, Marine Navigation and Piloting*, National Academy of Sciences, National Academy Press, Washington D.C., 1994.
- [49] Natural Resources Defense Council, *No Safe Harbor: Tanker Safety in America's Ports*, NRDC, New York, 1990.
- [50] Natural Resources Defense Council, *Safety at Bay: A Review of Oil Spill Prevention and Cleanup in U.S. Waters*, NRDC, New York, 1992
- [51] Noble P.G., "Safer Transport of Oil at Sea: A Social Responsibility for Naval Architects and Marine Engineers," *Marine Technology*, Vol. 30, No.2, April 1993.
- [52] Notthoff A., "Spill Sparks Reform, Leaves Lasting Scar," *Forum for Applied Research and Public Policy*, Winter, 1991.
- [53] Perrow C., *Normal Accidents*, Basic Books, New York, 1984.
- [54] Ramakumar R., *Engineering Reliability: Fundamentals and Applications*, Prentice-Hall, Englewood Cliffs, New Jersey, 1993.
- [55] Rasmussen N., "A Description of Probabilistic Safety Assessment Applied to Nuclear Power Plants," (unpublished), July, 1994.
- [56] Ratcliffe M., *Liquid Gold Ships - A History of the Tanker, 1859-1984*, Lloyd's of London Press, New York, 1985.
- [57] Reason J., *Human Error*, Cambridge University Press, New York, 1990.
- [58] Rutherford D., *Tanker Cargo Handling*, Charles Griffin & Co., LTD, London, 1980.
- [59] Sanders M.S., McCormick E.J., *Human Factors in Engineering and Design*, McGraw-Hill, New York, 1987

[60] Sheehan D., "Oil Pollution Act of 1990: Offshore Oil Spills, the Tanker Business, and the Regulation of Pollution Control," *Marine Technology Science Journal*, Vol 27, No.1 p 70.

[61] Sipes J.D., RADM USCG, "Oil Pollution Act of 1990," *Naval Engineers Journal*, July 1991.

[62] Sullivan G., *Supertanker!*, Dodd, Mead & Co. New York, 1978.

[63] United Nations Conference on Trade and Development, *Review of Maritime Transport 1992*, United Nations, New York, 1993

[64] U.S. Department of Transportation, *Preliminary Regulatory Impact Analysis: Financial Responsibility for Water Pollution (Vessels)*, USCG, July 12, 1993.

[65] von Zharen W.M., Duncan W., "Environmental Risk Assessment and Management in the Maritime Industry: The Interaction with ISO 9000, ISM and ISM Management Systems," Annual Meeting of The Society of Naval Architects and Marine Engineers, No. 7, 1994.

[66] WASH-1400 (NUREG 75/014), *Reactor Safety Study, An Assessment of Accidental Risks in US Commercial Nuclear Power Plants.*, October, 1975.

[67] Wilson M.B., "The Significance of Human Factors in the Prevention of Marine Spills," Technical Proceedings, Maritime Environmental Symposium 94, American Society of Naval Engineers, Society of American Military Engineers, February, 1994.

[68] Young C., "Seafarer Standards to be Revised," *Proceedings of the Marine Safety Council*, Vol. 52, No 3, May-June, 1995.