

REPORT DOCUMENTATION PAGE

Form Approved
OMB No. 0704-0188

Public reporting burden for this collection of information is estimated to average 1 hour per response, including the time for reviewing instructions, searching existing data sources, gathering and maintaining the data needed, and completing and reviewing the collection of information. Send comments regarding this burden estimate or any other aspect of this collection of information, including suggestions for reducing this burden, to Washington Headquarters Services, Directorate for Information Operations and Reports, 1215 Jefferson Davis Highway, Suite 1204, Arlington, VA 22202-4302, and to the Office of Management and Budget, Paperwork Reduction Project (0704-0188), Washington, DC 20503.

1. AGENCY USE ONLY (Leave blank)	2. REPORT DATE Sept. 30, 1996	3. REPORT TYPE AND DATES COVERED <i>Final 15 Jul 94 - 14 Jul 96</i>
----------------------------------	----------------------------------	--

4. TITLE AND SUBTITLE AERODYNAMIC DISSEMINATION	5. FUNDING NUMBERS DAAH04-94-G-0266
--	--

6. AUTHOR(S) Daniel D. Joseph Gordon S. Beavers	
---	--

7. PERFORMING ORGANIZATION NAME(S) AND ADDRESS(ES) Dept. of Aerospace Engineering and Mechanics University of Minnesota 110 Union St., Minneapolis, MN 55455	8. PERFORMING ORGANIZATION REPORT NUMBER
---	--

9. SPONSORING/MONITORING AGENCY NAME(S) AND ADDRESS(ES) U. S. Army Research Office P. O. Box 12211 Research Triangle Park, NC 27709-2211	10. SPONSORING/MONITORING AGENCY REPORT NUMBER ARO 33130.1-MA
---	--

11. SUPPLEMENTARY NOTES
The view, opinions, and/or findings contained in this report are those of the author(s) and should not be construed as an official Department of the Army position, policy, or decision, unless so designated by other documentation.

12a. DISTRIBUTION/AVAILABILITY STATEMENT Approved for public release; distribution unlimited.	12b. DISTRIBUTION CODE
--	------------------------

13. ABSTRACT (Maximum 200 words)

We have built a shock tube and liquid injection system for studying the aerodynamic breakup of thickened TEP and other viscoelastic liquids under conditions that simulate high altitude, high Mach number intercept conditions.

19961021 151

14. SUBJECT TERMS Shock tube, aerodynamic breakup, viscoelastic liquids	15. NUMBER OF PAGES 13
	16. PRICE CODE

17. SECURITY CLASSIFICATION OF REPORT UNCLASSIFIED	18. SECURITY CLASSIFICATION OF THIS PAGE UNCLASSIFIED	19. SECURITY CLASSIFICATION OF ABSTRACT UNCLASSIFIED	20. LIMITATION OF ABSTRACT UL
---	--	---	----------------------------------

AERODYNAMIC DISSEMINATION FINAL REPORT.

Problem

The problem addressed in this research program is to understand the dissemination of agents which are exposed to a high Mach number air stream (between about $M = 3$ and $M = 8$) at high altitudes. It is known that a liquid mass is reduced to a droplet cloud in hundreds of microseconds. It is believed that considerable amounts of vapor or mist are produced, but that the mechanisms of breakup, the distribution of drop sizes, the volume fractions of mist and vapor and the precise effects of thickening agents on the droplet distribution and breakup mechanism are not known. The unknowns are inputs for computer codes designed to predict how the droplet clouds are disseminated, where they will drift and the condition and size of the droplets that ultimately reach the ground.

The objectives which were put forth in our research proposal were to build a shock tube facility with a Mach 8 capability, to instrument it with systems capable of analyzing the breakup mechanics and the resulting droplet clouds, and thereby to obtain precise information about the formation of droplet clouds under conditions met in high speed and high altitude breakup through carefully controlled experiments on the breakup of thickened TEP and other liquids. We anticipate that controlled studies of this type will give us the information we need about droplet sizes at times of the order of 10 to 1,000 microseconds after impact under a variety of ambient conditions. We also think that these experiments will reveal what mechanisms are at work during breakup. These experiments are important because there is a great difference between the breakup of organic liquids (solvent) and thickened liquids (solvent plus polymers). Organic liquids shatter into small drops and mist at high Mach numbers, but at the highest Mach numbers tested so far (slightly supersonic), viscoelastic fluids are pulled into threads but don't shatter. It is important to see if and how these threads persist in the severe conditions behind a strong shock. We expect to obtain (possibly the first) data for thickened agents up to Mach 8 in our shock tube facility.

The objectives for the first year of this program were to design and construct the shock tube, followed in subsequent years by calibration, installation of diagnostic systems, and a broad range of experiments on the breakup of a variety of liquids under a range of intercept conditions. With funding for the second and third years of the program being suspended our progress has been limited to the first-year component of the project. We have built the shock tube and have carried out (so far) 45 shots for calibration purposes. Recently we have acquired funds from the National Science Foundation and the University of Minnesota to purchase a very high speed drum camera and a laser plus optical components for the development of a particle field holography system to measure droplet size distinctions after breakup.

Shock Tube

An overall view of the shock tube is shown in Fig. 1. Both the high pressure driver section and the low-pressure channel are built up from sections of extruded 6063-T6 aluminum tube. The facility consists of a driver section that can be varied in length between 6 and 10 feet, a double-diaphragm section, a low pressure channel with a maximum length capacity (governed by the size of the laboratory) of 34 feet, a windowed test-section approximately two and a half feet in length, and a dump tank with a volume of approximately 40 cubic feet.

The complete tube (driver, diaphragm, channel, and test section) is supported by ball-bearing carriages which ride on a precision rail. The rail in turn is mounted on a 6-inch aluminum I-beam which is attached through leveling screws to a set of five concrete columns. This arrangement allows for accurate leveling of the whole tube while giving ease of movement of the complete tube system for replacement of the diaphragms and for accommodating different lengths of the system.

In its normal configuration the channel consists of 5 sections of 6-foot lengths of tube bolted together by means of flanges which are kept in place using keys and key seats. A selection of channel lengths is available using 6-, 4-, and 2-foot sections.

The tube has a novel cross-sectional shape, selected to keep the stresses in the walls as low as possible and to give the greatest flow area for the cross-section

that could be extruded, while retaining flat side walls for continuity with the windows in the test section, as shown in Fig. 2. The outside of the tube has a circular cross-section 5.0 inches in diameter. The distance between the flat side walls is 3.000 inches; the upper and lower walls are circular arcs with diameter 3.760 inches.

The driver section is usually a single 6-foot length of the same extruded aluminum tube. It is sealed at the upstream end by a plate that bolts onto the upstream flange, and in which a port connects to piping from the vacuum pump and the compressed gas cylinders. A 2-D finite-elements analysis of the tube has shown a maximum internal admissible pressure of 4000 psi, twice the maximum pressure that we intend to use in the driver section. To verify the strength of the system, two short sections connected by a flange assembly were hydro-tested at 4000 psi.

The shock tube is fired by means of a double diaphragm system in which the intermediate section is filled to half the driver section pressure. When the system is ready to be fired, a solenoid valve connected to the intermediate section is used to drain that section, making the up-stream diaphragm too weak to withstand the pressure differential. Once the up-stream diaphragm has ruptured, the second one ruptures immediately. With opening time of about 10 ms, the solenoid valve can be used to synchronize the arrival of the shock in the test section with the liquid drop falling in the test section.

The test section, which can be seen in Fig. 3, is built around a 2-1/2-foot length of the extruded aluminum tube, and is designed to prevent any distortion under internal pressure, thus allowing 14-inch glass windows to be used. The design incorporates flat upper and lower external surfaces, thereby facilitating the mounting of auxiliary equipment, such as the drop injection system, on the test section. The design also makes it easy to remove the windows at any time.

Drop Injection System

A novel device has been built for the injection of a liquid drop of known volume into the test section at a predetermined time. The injector, shown schematically in Fig. 4, consists of a hypodermic syringe whose plunger displacement is controlled by a micrometer. The hypodermic drives liquid into a

small diameter tube which projects into the test-section from above. A drop of known volume is formed at the end of this tube. Upon receiving a signal from a pressure transducer in the channel, triggered by passage of the shock wave, a fast-acting solenoid withdraws the tube at high speed, leaving the drop suspended momentarily in the test section before it begins to move under gravity. The activation of the solenoid is timed to occur just prior to the shock wave reaching that point in the test section. The complete device is enclosed within a cylinder in which the pressure is equalized to the pressure in the test section of the shock tube. The drop injection system is mounted on the upper surface of the test section, as shown in Fig. 3.

Shock Tube Calibration

We have established a set of standard operating procedures for the shock tube, and so far we have carried out 45 shots for calibration and repeatability purposes. From these we have established a set of twelve test conditions that we will use in the initial phase of the breakup investigations. These are summarized in Fig. 5. They cover a shock Mach number range of 2 to 5, using either Helium or Nitrogen as the driver gas and air as the driven gas. This range of shock Mach numbers covers most of the live intercept conditions that might be anticipated. The shock tube simulations of live tests is discussed briefly in the last section appended to this report.

Current Status and Next Phase of Program

We have completed the first phase of the research project described in our original proposal. We now have a shock-tube facility and drop injection system to carry out aerodynamic breakup experiments. In the meantime, we have started to develop the flow diagnostic equipment that we require. To this end we have recently obtained funds from the National Science Foundation to purchase a rotating drum camera (200,000 frames/sec) and the components required for making and interrogating holograms in applying particle field holography techniques to the cloud of liquid droplets created by the aerodynamic breakup. We shall continue to seek funds to continue and complete our program on aerodynamic breakup of viscoelastic liquids. The problem is significant because with-

out more precise knowledge of the mechanisms and consequences of breakup and the condition of the droplet cloud immediately after breakup, we will not be able to predict or control the dissemination of agents.

Personnel

The following scientific personnel participate in this project:

Regent's Professor Daniel D. Joseph

Professor Gordon S. Beavers

Assistant Professor Jacque Belanger

APPENDIX

SHOCK TUBE SIMULATION OF LIVE TESTS

The shock tube is a simple and versatile device for simulating the critical parameters that influence liquid breakup at intercept conditions and for conducting systematic parametric studies of the relative importance of those parameters. Referring to the figures associated with the sample calculation given on the following page, in the live situation the conditions at the liquid slug are those generated by passage from known ambient conditions through a shock wave of known strength. In the shock tube experiments the appropriate "ambient" conditions are generated behind a moving normal shock wave, the strength of which is chosen to establish selected test conditions at the liquid drop. Two initial settings of the shock tube can be used to match these test conditions. They are:

- (1) the initial pressure in the shock tube (P_1), and
- (2) the initial shock wave Mach number (a particular Mach number is achieved by suitable choice of the pressure ratio between the driver and driven sections of the shock tube).

A sample calculation for the simulation of an incoming long range missile at 10,000 meters altitude at $M = 6.2$ is shown on the following page. For the results presented there the initial pressure (P_1) and shock Mach number (M_s) have been fixed so that the pressure (P_2) and temperature (T_2) in the region behind the normal part of the bow shock match the live test conditions. By doing this particular matching, the dynamic pressure (q) of the flow in front of the drop is closely matched with the q from the live tests (about 5% higher in the shock tube experiments). The flow velocity (V_2) behind the bow shock is not well reproduced in this case but additional tests could be performed to look specifically at the importance of this parameter.

To illustrate the ease of generating in the shock tube simulations covering the full range of intercept conditions we summarize in Table 1 five cases of missile intercept test conditions using typical reentry trajectory data. They go from the long range missile threat at high altitude (case no. 1) to the ones for lower altitude intercept and for shorter range missile. The five test conditions shown here do not represent in any way the limitations of the shock tube. Tests reproducing long range missile flying at $M = 8$ and dynamic pressure over a million (1×10^6) N/m^2 can readily be performed in our present facility. We also note that for the drop sizes which we will use in the shock tube (approximately 2.5 mm and larger) the flow Reynolds number in the shock tube experiments will always be higher than 5×10^4 . This Re is well into the turbulent regime ($> 1 \times 10^4$) which means that the shock tube experiments will be in the same turbulent regime as the live tests.

For the examples presented above we have chosen to match the pressure (P_2) and temperature (T_2), but we could just as easily match other parameters. For example, if the dynamic pressure (q) turns out to be a primary parameter, it is straightforward to match it perfectly with the live tests. In that case, the pressure in the shock tube experiment (P_2) would be off by a few percent but the temperature (T_2) could still be matched exactly. Again, if it turns out that the velocity parameter (V_2) needs to be matched, it could be achieved but the temperature would then be significantly off compared to the live tests. The enormous benefit of these shock tube experiments is that they will allow us to study the effects of all these parameters. Even though the actual "free stream" Mach number cannot be matched in the shock tube experiments, the flow conditions experienced by the liquid drop are closely simulated. A systematic study of both the "free stream" temperature and velocity (the two variables in the Mach number) will determine which one of these parameters is the most important. A more extensive parametric study will allow us to determine which parameters are critical from the point of view of simulations. This study could then be used to limit the number of parameters needed to be examined in field experiments.

Shock Tube for Studies of Drop Breakup:

Live tests and shock tube experiments comparison

Live test conditions

Incoming long range missile at $M = 6.2$ ($h = 10,000$ m) :

- The numerical values are presented in the initial drop velocity frame of reference.
- The region 2 test conditions are evaluated just downstream of the normal shock in front of the drop.

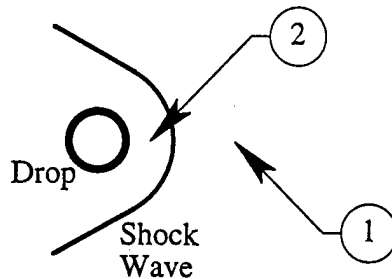

$$\begin{aligned}
 M_1 &= 6.2 \\
 P_1 &= 26.5 \text{ kPa} \\
 T_1 &= 223 \text{ K} \\
 V_1 &= 1860 \text{ m/s} \\
 q &= 7.2 \times 10^5 \text{ kg/ms}^2 \\
 M_2 &= 0.403 \\
 P_2 &= 1184 \text{ kPa} \\
 T_2 &= 1877 \text{ K} \\
 V_2 &= 350 \text{ m/s}
 \end{aligned}$$

Shock tube experiments

The flow establishment around the drop is achieved by two successive processes:

1 - Flow acceleration using the shock tube

- The region 1 conditions are the initial conditions in the shock tube before the firing.

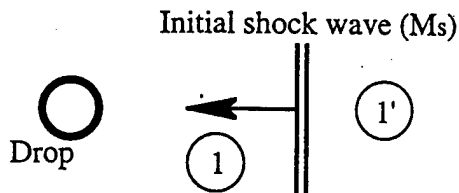

$$\begin{aligned}
 M_s &= 4.35 \\
 P_1 &= 19 \text{ kPa} \\
 T_1 &= 295 \text{ K} \\
 V_1 &= 0 \text{ m/s} \\
 M_{1'} &= 1.60 \\
 P_{1'} &= 416 \text{ kPa} \\
 T_{1'} &= 1362 \text{ K} \\
 V_{1'} &= 1180 \text{ m/s}
 \end{aligned}$$

2 - Flow establishment around the drop after the initial shock wave passage

- Flow conditions presented in the initial drop velocity frame of reference, which is the lab. frame of reference.

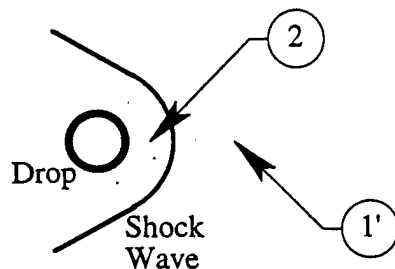

$$\begin{aligned}
 M_{1'} &= 1.60 \\
 P_{1'} &= 416 \text{ kPa} \\
 T_{1'} &= 1362 \text{ K} \\
 V_{1'} &= 1180 \text{ m/s} \\
 q &= 7.4 \times 10^5 \text{ kg/ms}^2 \\
 M_2 &= 0.669 \\
 P_2 &= 1171 \text{ kPa} \\
 T_2 &= 1888 \text{ K} \\
 V_2 &= 582 \text{ m/s}
 \end{aligned}$$

Test Cond.	1	2	3	4	5
Threat	Long Range	Long Range	Mid-Range	Short Range	Short Range
Altitude (km)	15	10	5	15	10
<u>Live Tests</u>					
M_1	6.9	6.2	4.4	5.2	4.8
P_1 (kPa)	12.1	26.5	54	12.1	26.5
T_1 (K)	217	223	255	217	223
V_1 (m/s)	2036	1860	1408	1534	1440
q (N/m ²)	4.04×10^5	7.19×10^5	7.34×10^5	2.29×10^5	4.31×10^5
M_2	0.398	0.403	0.426	0.413	0.418
P_2 (kPa)	670.1	1184	1211	379.7	707.9
T_2 (K)	2213	1877	1199	1345	1208
V_2 (m/s)	374.9	350.3	295.3	302.9	292.1
<u>Shock Tube</u>					
M_s	4.75	4.35	3.40	3.60	3.40
P_1 (kPa)	8.6	19	40	10.5	23
T_1 (K)	295	295	295	295	295
V_1 (m/s)	0	0	0	0	0
$M_{1'}$	1.64	1.60	1.45	1.49	1.45
$P_{1'}$ (kPa)	224.9	416.3	532.8	157.0	306.4
$T_{1'}$ (K)	1571	1362	938	1019	938
$V_{1'}$ (m/s)	1300	1180	889.5	951.5	889.5
q (N/m ²)	4.23×10^5	7.44×10^5	7.86×10^5	2.44×10^5	4.52×10^5
M_2	0.657	0.669	0.719	0.705	0.719
P_2 (kPa)	667.7	1171	1221	380.4	701.8
T_2 (K)	2223	1888	1208	1338	1208
V_2 (m/s)	619.9	581.8	500.2	515.9	500.2

Table 1. Live tests and shock tube experiments comparison.



FIG. 1 Shock tube facility

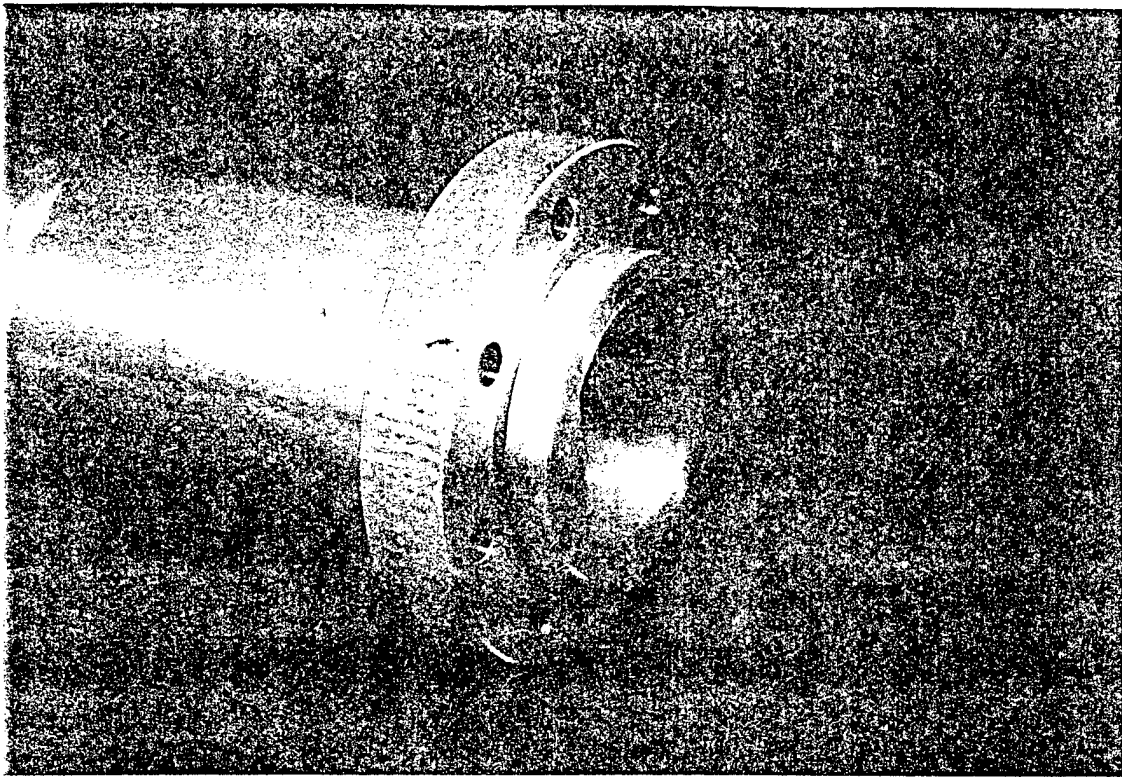

FIG. 2(a) Channel section with key and flange assembled.

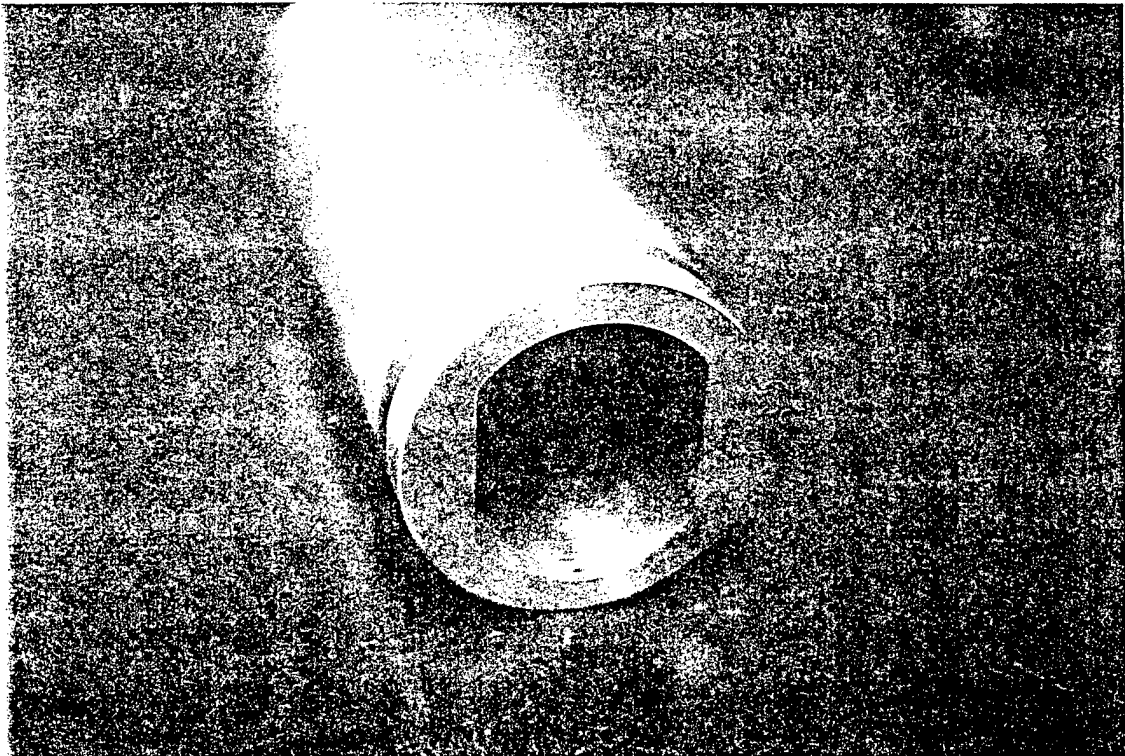

FIG. 2(b) Channel cross-section.

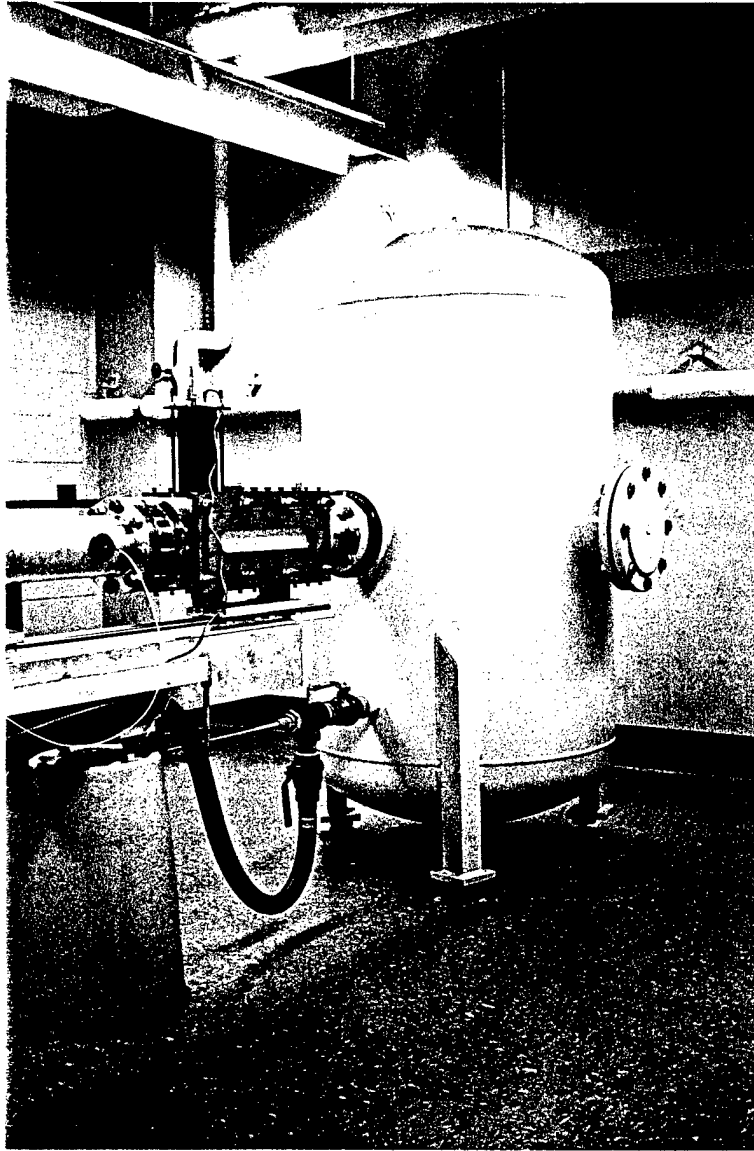
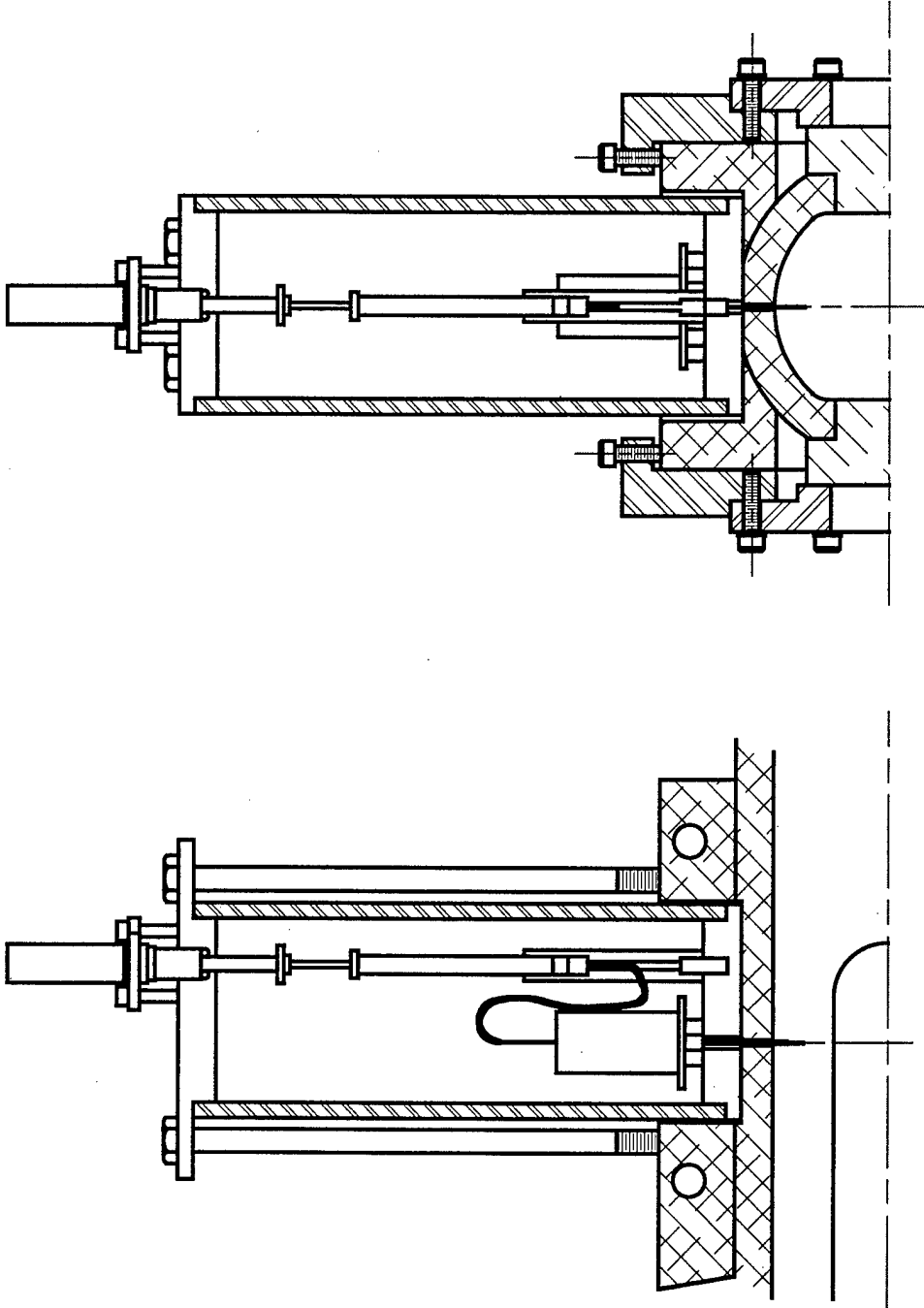

FIG. 3 Shock tube test section with liquid injection system
in place



AEM Shock Tube

Test Section: Injection Assembly

Quantity: Material:

Units: Inches Unless Noted: Break Sharp Corners

Date: 05/30/96 Drawn By: Jacques Bélanger

FIG. 4 Schematic of liquid injection system

Test Conditions

(08/02/96)

Test Condition	Mach Number	Main Diaphragm (x 0.001 in)	Test Section Diaphragm (x 0.0015 in)	Shock Tube Pressure (kPa)	Driver Gas	Diaphragm Space Pressure (MPa)	Driver Section Pressure (MPa)
1	2.0	16	2	58.0	N ₂	1.29	2.86
2	2.5	16	1	12.0	N ₂	1.24	2.81
3	3.0	16	1	3.0	N ₂	1.23	2.80
4	3.0	16	2	50.0	He	1.28	2.85
5	4.0	16	1	12.0	He	1.24	2.81
6	5.0	16	1	3.8	He	1.23	2.80
7	2.0	2x16	4	90.0	N ₂	2.21	4.85
8	2.5	2x16	1	18.0	N ₂	2.14	4.78
9	3.0	2x16	1	4.5	N ₂	2.12	4.76
10	3.0	2x16	3	75.0	He	2.20	4.85
11	4.0	2x16	1	18.0	He	2.14	4.78
12	5.0	2x16	1	5.8	He	2.13	4.77

FIG. 5 Test conditions for first phase of breakup experiments